



# **VT82C686A**

## **“Super South” South Bridge**

**PSIPC**

**PCI Super-I/O Integrated Peripheral Controller**

**PC99 COMPLIANT PCI-TO-ISA BRIDGE**

**WITH INTEGRATED SUPER-I/O (FDC, LPT, COM1/2, AND IR),  
INTEGRATED SOUNDBLASTER/DIRECTSOUND AC97 AUDIO,  
ULTRADMA-33/66 MASTER MODE PCI-EIDE CONTROLLER,  
USB CONTROLLER, KEYBOARD CONTROLLER, RTC,  
DISTRIBUTED DMA, SERIAL IRQ, PLUG AND PLAY,  
ACPI, ENHANCED POWER MANAGEMENT, SMBUS, AND  
TEMPERATURE, VOLTAGE, AND FAN-SPEED MONITORING**

Revision 1.54  
February 25, 2000

**VIA TECHNOLOGIES, INC.**

## Copyright Notice:

Copyright © 1998, 1999, 2000 VIA Technologies Incorporated. Printed in the United States. ALL RIGHTS RESERVED.

No part of this document may be reproduced, transmitted, transcribed, stored in a retrieval system, or translated into any language, in any form or by any means, electronic, mechanical, magnetic, optical, chemical, manual or otherwise without the prior written permission of VIA Technologies Incorporated.

VT82C686A and Super South may only be used to identify products of VIA Technologies, Inc.



ia is a registered trademark of VIA Technologies, Incorporated.

PS/2™ is a registered trademark of International Business Machines Corp.

Pentium™, Pentium-Pro™, Pentium-II™, Pentium-III™, Celeron™, and GTL+™ are registered trademarks of Intel Corp.

Windows 95™, Windows 98™, Windows NT™, and Plug and Play™ are registered trademarks of Microsoft Corp.

PCI™ is a registered trademark of the PCI Special Interest Group.

All trademarks are the properties of their respective owners.

## Disclaimer Notice:

No license is granted, implied or otherwise, under any patent or patent rights of VIA Technologies. VIA Technologies makes no warranties, implied or otherwise, in regard to this document and to the products described in this document. The information provided by this document is believed to be accurate and reliable to the publication date of this document. However, VIA Technologies assumes no responsibility for any errors in this document. Furthermore, VIA Technologies assumes no responsibility for the use or misuse of the information in this document and for any patent infringements that may arise from the use of this document. The information and product specifications within this document are subject to change at any time, without notice and without obligation to notify any person of such change.

## Offices:

### USA Office:

1045 Mission Court

Fremont, CA 94539

USA

Tel: (510) 683-3300

Fax: (510) 683-3301

### Taipei Office:

8<sup>th</sup> Floor, No. 533

Chung-Cheng Road, Hsin-Tien

Taipei, Taiwan ROC

Tel: (886-2) 218-5452

Fax: (886-2) 218-5453

## Online Services:

Home Page: <http://www.via.com.tw> –or– <http://www.viatech.com>

FTP Server: <ftp.via.com.tw>

BBS: 886-2-2185208

## REVISION HISTORY

Document Release	Date	Revision	Initials
Revision 0.1	2/10/98	Initial release based on 82C596 "Mobile South" Data Sheet revision 0.3	DH
Revision 0.2	3/17/98	Updated features, overview, pins, regs; Added pin list, Sup-IO, HWM, audio	DH
Revision 0.3	4/20/98	Revised pinouts, fixed TC, changed reg defs, added regs in funcs 1, 3, & 4:	DH
Revision 0.4	4/29/98	Corrected TC, features, pin descriptions, f4/game port regs, removed timing	DH
Revision 0.5	5/27/98	Updated feature bullets, pinouts, registers in functions 0-4 and I/O	DH
Revision 0.6	5/29/98	Updated registers in functions 1, 3, and 4	DH
Revision 0.72	12/1/98	Changed name to 686A, updated feature bullets, pin names, & register defs	DH
Revision 0.8	12/7/98	Updated register definitions	DH
Revision 0.9	12/9/98	Updated register definitions	DH
Revision 1.0	1/15/99	Corrected feature bullets, pin typos, ROMCS# description, f0Rx8, f4Rx2	DH
Revision 1.1	4/15/99	Fixed block diagram, pinouts, register descriptions and electrical specs	DH
Revision 1.23	5/17/99	Fixed GPI1,5,6, GPO1-3,6, PCS0#, DRQ2/DACK2#, MCCS#, PCS0#, GPO0/SLOWCLK, GPIOA-D, DACK0-7# IRQ option, FDC on LPT Fixed SuperIO Rx F0-1,F6; FDCIObase+1,Fn0Rx43,59,5B-C,68,74-7F,80,88, 88,8A-F,Fn1Rx43,45,54,Fn2&3Rx8,41,42,Fn4Rx54,D2,PMUIORx0,20, 22,24,28/2A,2C,38,40,42,44-5,HWMIORx28-29,35-38,Fn5Rx6,2C,42,48	DH
Revision 1.24	6/18/99	Changed DRVEN to DRVDEN, moved PME# from W11 to T11 MCCS# on U5, SCIOOUT# on U8 for "CF" (opposite prior to "CF") Fixed F0 Rx42,74,76, F1 Rx43, F5/6 Rx48, PMU I/O Rx44	DH
Revision 1.3	6/25/99	Rev 1.3x created to document CD/CE <b>only</b> (info on version CF removed)	DH
Revision 1.4	6/25/99	Updated U5/U8 pin defs; fixed Rx74[5,7],76[4-3],77[0],PMUIO Rx44[5,3-1]	DH
Revision 1.42	7/7/99	Fixed typo in SUSST1# pin description; Fixed Super-I/O RxF8 table Modified F0 Rx59, F1 Rx6,9,34,3C,41,54,71-75,79-7D,C0-C7, F2/3 Rx41-42,80-84, F4 Rx4C[0], PMU I/O Rx4[0],20-21[1],22-23[1],24-25[1],2C-2D[3], HWM IO Rx42[2-1],44[2-1], F5/6 Rx4A-4B, IO Base 0 Rx12[6]	DH
Revision 1.43	10/7/99	Fixed typo in PDIOR#/SDIOR# pin descriptions & Func 4 Rx42[4]	DH
Revision 1.45	12/3/99	Added SCIOOUT# to GPIO11 (pin U8), fixed typos in CHAS pin description Fixed typos in Serial Port 2 register descriptions, changed to new logo format	DH
Revision 1.5	12/21/99	Changed FDC "OD" pin types to "O"; fixed table 2 ECP port address range Fixed register summary tables: SuperIO Cfg E2; FDC 4, 7 Fixed reg descriptions: SuperIO Cfg E2 & EE defaults; FDCbase+4 & +7; LPTbase+402; COM1/2 index value references; Com1/2 Divisor offset	DH
Revision 1.51	1/7/00	Changed silicon version CF to CF/CG (CG same programming / pinout as CF) Fixed IR description (no 3 <sup>rd</sup> serial port – muxed on COM2) Fixed Parallel Port I/O Index, FDC I/O index & Base+7 register description Fixed typo in Func 4 Rx48 description Changed Pwr Mgmt I/O Rx44[3-2] (different for CD/DE & CF/CG silicon)	DH
Revision 1.52	1/17/00	Added internal I/O APIC pin names; fixed LID name polarity in pin diagram Corrected F0 Rx41[6],58,74[7],77[4], F1 Rx54[5], F2/3 Rx43, F4 Rx4D[3],54[3-2],55[2], PMU IO Rx0[8], added APIC regs	DH
Revision 1.53	2/8/00	Fixed feature bullet typos, APIC/GPI/GPO pin descriptions, F0 Rx76[4],77[4] Fixed Func 5/6 AC97 reg summary tables; KBC Ctrl bit-3 changed to reserved	DH
Revision 1.54	2/25/00	Fixed pin direction for APICD0-1 pins (changed from O to IO) Fixed defaults in register tables for Func 1 Rx40, 41, 43, 45, 50 Added notea to F0 Rx41[3] & Rx45; fixed F1 Rx45[1-0] & misc typos	DH

# TABLE OF CONTENTS

<b>REVISION HISTORY</b> .....	<b>I</b>
<b>TABLE OF CONTENTS</b> .....	<b>II</b>
<b>LIST OF FIGURES</b> .....	<b>IV</b>
<b>LIST OF TABLES</b> .....	<b>IV</b>
<b>OVERVIEW</b> .....	<b>4</b>
<b>PINOUTS</b> .....	<b>6</b>
<b>PIN DIAGRAM</b> .....	<b>6</b>
<b>PIN LISTS</b> .....	<b>7</b>
<b>PIN DESCRIPTIONS</b> .....	<b>9</b>
<b>REGISTERS</b> .....	<b>27</b>
<b>REGISTER OVERVIEW</b> .....	<b>27</b>
<b>REGISTER DESCRIPTIONS</b> .....	<b>39</b>
<b>Legacy I/O Ports</b> .....	<b>39</b>
Keyboard Controller Registers .....	40
DMA Controller I/O Registers .....	42
Interrupt Controller Registers .....	43
Timer / Counter Registers .....	43
CMOS / RTC Registers.....	44
<b>Super-I/O Configuration Index / Data Registers</b> .....	<b>45</b>
<b>Super-I/O Configuration Registers</b> .....	<b>45</b>
<b>Super-I/O I/O Ports</b> .....	<b>48</b>
Floppy Disk Controller Registers.....	48
Parallel Port Registers .....	49
Serial Port 1 Registers.....	50
Serial Port 2 Registers.....	51
<b>SoundBlaster Pro Port Registers</b> .....	<b>52</b>
FM Registers .....	52
Mixer Registers .....	52
Sound Processor Registers.....	52
<b>Game Port Registers</b> .....	<b>53</b>
<b>PCI Configuration Space I/O</b> .....	<b>54</b>
<b>Function 0 Registers - PCI to ISA Bridge</b> .....	<b>55</b>
PCI Configuration Space Header .....	55
ISA Bus Control.....	55
Plug and Play Control .....	59
Distributed DMA / Serial IRQ Control .....	61
Miscellaneous / General Purpose I/O.....	62
<b>Function 1 Registers - Enhanced IDE Controller</b> .....	<b>68</b>
PCI Configuration Space Header .....	68
IDE-Controller-Specific Configuration Registers .....	70
IDE I/O Registers .....	75
<b>Function 2 Registers - USB Controller Ports 0-1</b> .....	<b>76</b>
PCI Configuration Space Header .....	76
USB-Specific Configuration Registers.....	77
USB I/O Registers.....	78
<b>Function 3 Registers - USB Controller Ports 2-3</b> .....	<b>79</b>
PCI Configuration Space Header .....	79
USB-Specific Configuration Registers.....	80
USB I/O Registers.....	81

<b>Function 4 Regs - Power Management, SMBus and HWM.....</b>	<b>82</b>
PCI Configuration Space Header .....	82
Power Management-Specific PCI Configuration Registers .....	83
Hardware-Monitor-Specific Configuration Registers .....	90
System Management Bus-Specific Configuration Registers .....	90
Power Management I/O-Space Registers .....	91
System Management Bus I/O-Space Registers.....	100
Hardware Monitor I/O Space Registers .....	103
<b>Function 5 &amp; 6 Registers - AC97 Audio &amp; Modem Codecs .....</b>	<b>107</b>
PCI Configuration Space Header – Function 5 Audio .....	107
PCI Configuration Space Header – Function 6 Modem.....	108
Function 5 & 6 Codec-Specific Configuration Registers .....	109
I/O Base 0 Registers –Audio/Modem Scatter/Gather DMA.....	111
I/O Base 1 Registers – Audio FM NMI Status Registers .....	115
I/O Base 2 Registers – MIDI / Game Port.....	115
Memory Mapped I/O APIC Registers (CG Silicon).....	116
Indexed I/O APIC 32-Bit Registers (CG Silicon) .....	116
<b>FUNCTIONAL DESCRIPTIONS .....</b>	<b>118</b>
<b>POWER MANAGEMENT.....</b>	<b>118</b>
Power Management Subsystem Overview .....	118
Processor Bus States .....	118
System Suspend States and Power Plane Control .....	119
General Purpose I/O Ports.....	119
Power Management Events .....	120
System and Processor Resume Events .....	120
Legacy Power Management Timers .....	121
System Primary and Secondary Events .....	121
Peripheral Events .....	121
<b>ELECTRICAL SPECIFICATIONS.....</b>	<b>122</b>
<b>ABSOLUTE MAXIMUM RATINGS .....</b>	<b>122</b>
<b>DC CHARACTERISTICS.....</b>	<b>122</b>
<b>PACKAGE MECHANICAL SPECIFICATIONS .....</b>	<b>123</b>

## LIST OF FIGURES

FIGURE 1. PC SYSTEM CONFIGURATION USING THE VT82C686A .....	5
FIGURE 2. VT82C686A BALL DIAGRAM (TOP VIEW).....	6
FIGURE 3. VT82C686A PIN LIST ( <u>NUMERICAL ORDER</u> ) .....	7
FIGURE 4. VT82C686A PIN LIST ( <u>ALPHABETICAL ORDER</u> ).....	8
FIGURE 5. STRAP OPTION CIRCUIT.....	60
FIGURE 6. POWER MANAGEMENT SUBSYSTEM BLOCK DIAGRAM .....	118
FIGURE 8. MECHANICAL SPECIFICATIONS – 352 PIN BALL GRID ARRAY PACKAGE.....	123

## LIST OF TABLES

TABLE 1. PIN DESCRIPTIONS.....	9
TABLE 2. SYSTEM I/O MAP .....	27
TABLE 3. REGISTERS.....	28
TABLE 4. KEYBOARD CONTROLLER COMMAND CODES .....	41
TABLE 5. CMOS REGISTER SUMMARY.....	44

# **VT82C686A PSIPC PCI SUPER-I/O INTEGRATED PERIPHERAL CONTROLLER**

**PC99 COMPLIANT PCI-TO-ISA BRIDGE  
WITH INTEGRATED SUPER-I/O (FDC, LPT, COM1/2, AND IR),  
INTEGRATED HARDWARE SOUNDBLASTER/DIRECT SOUND AC97 AUDIO,  
ULTRADMA-33/66 MASTER MODE PCI-EIDE CONTROLLER,  
USB CONTROLLER, KEYBOARD CONTROLLER, RTC,  
DISTRIBUTED DMA, SERIAL IRQ, PLUG AND PLAY,  
ACPI, ENHANCED POWER MANAGEMENT, SMBUS, AND  
TEMPERATURE, VOLTAGE, AND FAN-SPEED MONITORING**

- **Inter-operable with VIA and other Host-to-PCI Bridges**
  - Combine with VT82C598 for a complete Super-7 (66/75/83/100MHz) PCI / AGP / ISA system (Apollo MVP3)
  - Combine with VT8501 for a complete Super-7 system with integrated 2D / 3D graphics (Apollo MVP4)
  - Combine with VT82C693 for a complete 66 / 100 / 133 MHz Socket-370 or Slot-1 system (Apollo Pro133)
  - Combine with VT8601 for a complete 66 / 100 / 133 MHz Socket-370 or Slot-1 system with integrated 2D / 3D graphics (Apollo ProMedia)
  - Inter-operable with Intel or other Host-to-PCI bridges for a complete PC99 compliant PCI / AGP / ISA system
- **PCI to ISA Bridge**
  - Integrated ISA Bus Controller with integrated DMA, timer, and interrupt controller
  - Integrated Keyboard Controller with PS2 mouse support
  - Integrated DS12885-style Real Time Clock with extended 256 byte CMOS RAM and Day/Month Alarm for ACPI
  - Integrated USB Controller with root hub and four function ports
  - Integrated UltraDMA-33/66 master mode EIDE controller with enhanced PCI bus commands
  - PCI-2.2 compliant with delay transaction and remote power management
  - Eight double-word line buffer between PCI and ISA bus
  - One level of PCI to ISA post-write buffer
  - Supports type F DMA transfers
  - Distributed DMA support for ISA legacy DMA across the PCI bus
  - Serial interrupt for docking and non-docking applications
  - Fast reset and Gate A20 operation
  - Edge trigger or level sensitive interrupt
  - Flash EPROM, 4Mb EPROM and combined BIOS support
  - Supports positive and subtractive decoding

- **UltraDMA-33 / 66 Master Mode PCI EIDE Controller**
  - Dual channel master mode PCI supporting four Enhanced IDE devices
  - Transfer rate up to 33MB/sec to cover PIO mode 4, multi-word DMA mode 2 drives, and UltraDMA-33 interface
  - Increased reliability using UltraDMA-66 transfer protocols
  - Thirty-two levels (doublewords) of prefetch and write buffers
  - Dual DMA engine for concurrent dual channel operation
  - Bus master programming interface for SFF-8038i rev.1.0 and Windows-95 compliant
  - Full scatter gather capability
  - Support ATAPI compliant devices including DVD devices
  - Support PCI native and ATA compatibility modes
  - Complete software driver support
  
- **Integrated Super IO Controller**
  - Supports 2 serial ports, IR port, parallel port, and floppy disk controller functions
  - Two UARTs for Complete Serial Ports
    - Programmable character lengths (5,6,7,8)
    - Even, odd, stick or no parity bit generation and detection
    - Programmable baud rate generator
    - High speed baud rate (230Kbps, 460Kbps) support
    - Independent transmit/receiver FIFOs
    - Modem Control
    - Plug and play with 96 base IO address and 12 IRQ options
  - Infrared-IrDA (HPSIR) and ASK (Amplitude Shift Keyed) IR port multiplexed on COM2
  - Multi-mode parallel port
    - Standard mode, ECP and EPP support
    - Plug and play with 192 base IO address, 12 IRQ and 4 DMA options
  - Floppy Disk Controller
    - 16 bytes of FIFO
    - Data rates up to 1Mbps
    - Perpendicular recording driver support
    - Two FDDs with drive swap support
    - Plug and play with 48 base IO address, 12 IRQ and 4 DMA options
  
- **SoundBlaster Pro Hardware and Direct Sound Ready AC97 Digital Audio Controller**
  - Dual full-duplex Direct Sound channels between system memory and AC97 link
  - PCI master interface with scatter / gather and bursting capability
  - 32 byte FIFO of each direct sound channel
  - Host based sample rate converter and mixer
  - Standard v1.0 or v2.0 AC97 Codec interface for single or cascaded AC97 Codec's from multiple vendors
  - Loopback capability for re-directing mixed audio streams into USB and 1394 speakers
  - Hardware SoundBlaster Pro for Windows DOS box and real-mode DOS legacy compatibility
  - Plug and play with 4 IRQ, 4 DMA, and 4 I/O space options for SoundBlaster Pro and MIDI hardware
  - Hardware assisted FM synthesis for legacy compatibility
  - Direct two game ports and one MIDI port interface
  - Complete software driver support for Windows-95/98/2000 and Windows-NT
  
- **Voltage, Temperature, Fan Speed Monitor and Controller**
  - Five positive voltage (one internal), three temperature (one internal) and two fan-speed monitoring
  - Programmable control, status, monitor and alarm for flexible desktop management
  - External thermister or internal bandgap temperature sensing
  - Automatic clock throttling with integrated temperature sensing
  - Internal core VCC voltage sensing
  - Flexible external voltage sensing arrangement (any positive supply and battery)



- **Universal Serial Bus Controller**
  - USB v.1.1 and Intel Universal HCI v.1.1 compatible
  - Eighteen level (doublewords) data FIFO with full scatter and gather capability
  - Root hub and four function ports
  - Integrated physical layer transceivers with optional over-current detection status on USB inputs
  - Legacy keyboard and PS/2 mouse support
- **System Management Bus Interface**
  - Host interface for processor communications
  - Slave interface for external SMBus masters
- **Sophisticated PC99-Compatible Mobile Power Management**
  - Supports both ACPI (Advanced Configuration and Power Interface) and legacy (APM) power management
  - ACPI v1.0 Compliant
  - APM v1.2 Compliant
  - CPU clock throttling and clock stop control for complete ACPI C0 to C3 state support
  - PCI bus clock run, Power Management Enable (PME) control, and PCI/CPU clock generator stop control
  - Supports multiple system suspend types: power-on suspends with flexible CPU/PCI bus reset options, suspend to DRAM, and suspend to disk (soft-off), all with hardware automatic wake-up
  - Multiple suspend power plane controls and suspend status indicators
  - One idle timer, one peripheral timer and one general purpose timer, plus 24/32-bit ACPI compliant timer
  - Normal, doze, sleep, suspend and conserve modes
  - Global and local device power control
  - System event monitoring with two event classes
  - Primary and secondary interrupt differentiation for individual channels
  - Dedicated input pins for power and sleep buttons, external modem ring indicator, and notebook lid open/close for system wake-up
  - Up to 12 general purpose input ports and 23 output ports
  - Multiple internal and external SMI sources for flexible power management models
  - One programmable chip select and one microcontroller chip select
  - Enhanced integrated real time clock (RTC) with date alarm, month alarm, and century field
  - Thermal alarm on either external or any combination of three internal temperature sensing circuits
  - Hot docking support
  - I/O pad leakage control
- **Plug and Play Controller**
  - PCI interrupts steerable to any interrupt channel
  - Steerable interrupts for integrated peripheral controllers: USB, floppy, serial, parallel, audio, soundblaster, MIDI
  - Steerable DMA channels for integrated floppy, parallel, and soundblaster pro controllers
  - One additional steerable interrupt channel for on-board plug and play devices
  - Microsoft Windows 98™, Windows NT™, Windows 95™ and plug and play BIOS compliant
- **Integrated I/O APIC (Advanced Peripheral Interrupt Controller) (CG Silicon)**
- **Built-in NAND-tree pin scan test capability**
- **0.35um, 3.3V, low power CMOS process**
- **Single chip 27x27 mm, 352 pin BGA**

## OVERVIEW

The VT82C686A PSIPC (PCI Super-I/O Integrated Peripheral Controller) is a high integration, high performance, power-efficient, and high compatibility device that supports Intel and non-Intel based processor to PCI bus bridge functionality to make a complete Microsoft PC99-compliant PCI/ISA system. In addition to complete ISA extension bus functionality, the VT82C686A includes standard intelligent peripheral controllers:

- a) Master mode enhanced IDE controller with dual channel DMA engine and interlaced dual channel commands. Dedicated FIFO coupled with scatter and gather master mode operation allows high performance transfers between PCI and IDE devices. In addition to standard PIO and DMA mode operation, the VT82C686A also supports the UltraDMA-33 standard to allow reliable data transfer rates up to 33MB/sec throughput. The VT82C686A also supports the UltraDMA-66 standard. The IDE controller is SFF-8038i v1.0 and Microsoft Windows-family compliant.
- b) Universal Serial Bus controller that is USB v1.1 and Universal HCI v1.1 compliant. The VT82C686A includes the root hub with four function ports with integrated physical layer transceivers. The USB controller allows hot plug and play and isochronous peripherals to be inserted into the system with universal driver support. The controller also implements legacy keyboard and mouse support so that legacy software can run transparently in a non-USB-aware operating system environment.
- c) Keyboard controller with PS2 mouse support.
- d) Real Time Clock with 256 byte extended CMOS. In addition to the standard ISA RTC functionality, the integrated RTC also includes the date alarm, century field, and other enhancements for compatibility with the ACPI standard.
- e) Notebook-class power management functionality compliant with ACPI and legacy APM requirements. Multiple sleep states (power-on suspend, suspend-to-DRAM, and suspend-to-Disk) are supported with hardware automatic wake-up. Additional functionality includes event monitoring, CPU clock throttling and stop (Intel processor protocol), PCI bus clock stop control, modular power, clock and leakage control, hardware-based and software-based event handling, general purpose I/O, chip select and external SMI.
- f) Hardware monitoring subsystem for managing system / motherboard voltage levels, temperatures, and fan speeds
- g) Full System Management Bus (SMBus) interface.
- h) Two 16550-compatible serial I/O ports with infrared communications port option on the second port.
- i) Integrated PCI-mastering dual full-duplex direct-sound AC97-link-compatible sound system. Hardware soundblaster-pro and hardware-assisted FM blocks are included for Windows DOS box and real-mode DOS compatibility. Loopback capability is also implemented for directing mixed audio streams into USB and 1394 speakers for high quality digital audio.
- j) Two game ports and one MIDI port
- k) ECP/EPP-capable parallel port
- l) Standard floppy disk drive interface
- m) Distributed DMA capability for support of ISA legacy DMA over the PCI bus. Serial IRQ is also supported for docking and non-docking applications.
- n) Plug and Play controller that allows complete steerability of all PCI interrupts and internal interrupts / DMA channels to any interrupt channel. One additional steerable interrupt channel is provided to allow plug and play and reconfigurability of on-board peripherals for Windows family compliance.
- o) Internal I/O APIC (Advanced Programmable Interrupt Controller)

The VT82C686A also enhances the functionality of the standard ISA peripherals. The integrated interrupt controller supports both edge and level triggered interrupts channel by channel. The integrated DMA controller supports type F DMA in addition to standard ISA DMA modes. Compliant with the PCI-2.2 specification, the VT82C686A supports delayed transactions and remote power management so that slower ISA peripherals do not block the traffic of the PCI bus. Special circuitry is built in to allow concurrent operation without causing dead lock even in a PCI-to-PCI bridge environment. The chip also includes eight levels (doublewords) of line buffers from the PCI bus to the ISA bus to further enhance overall system performance.

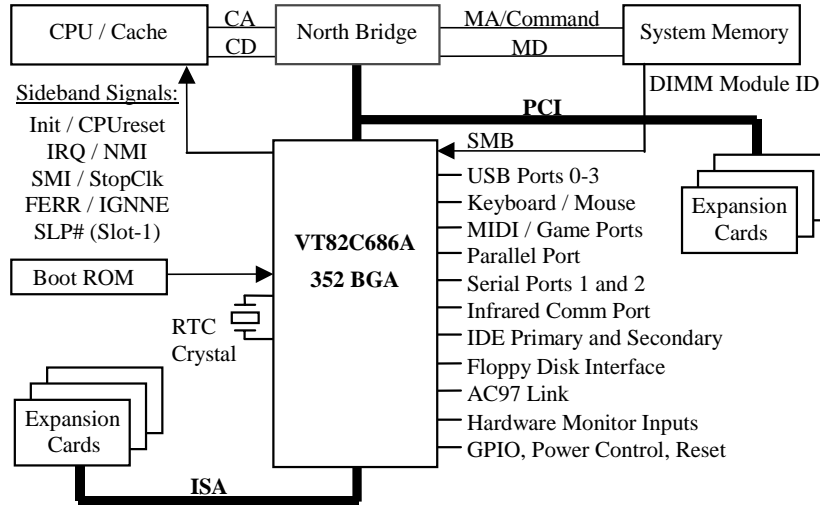

Figure 1. PC System Configuration Using the VT82C686A

# PINOOTS

## Pin Diagram

Figure 2. VT82C686A Ball Diagram (Top View)

Key	1	2	3	4	5	6	7	8	9	10	11	12	13	14	15	16	17	18	19	20
A	SMEM R#	IOCH RDY	USB PO+	USB P2+	KB DT	WRT PRT#	W DATA#	DS 1#	CTS 2#	DCD 2#	TXD 1	DCD 1#	PD 7	PD 2	ERR#	PIRQ A#	AD 31	AD 28	AD 26	AD 25
B	SMEM W#	AEN	USB PO-	USB P2-	USB P3+	R DATA#	W GATE#	DS 0#	DTR 2#	RXD 2	RTS 1#	RXD 1	ACK# 3	PD 3	PD 0	PCI RST#	PIRQ D#	AD 29	AD 27	AD 24
C	ROM CS#	IO W#	USB CLK	USB P1+	MS DT	DSK CHG#	HD SEL#	MTR 1#	RI 2#	DSR 2#	CTS 1#	DSR 1#	BUSY 4	PD 4	P INIT#	AUTO FD#	PIRQ C#	AD 30	C/BE 3#	ID SEL
D	IO R#	DACK 3#	DRQ 3	USB P1-	MS CK	DRV DEN1	IN DEX#	DIR#	DRV DEN0	TXD 2	DTR 1#	IR RX	PE 5	PD 5	PD 1	STR OBE#	PIRQ B#	AD 23	AD 22	AD 21
E	DACK 1#	DRQ 1	RFSH#	OSC	KB CK	USB P3-	TRK 00#	STEP#	MTR 0#	RTS 2#	RI 1#	IR TX	SLCT 6	PD 6	SLCT IN#	P CLK	AD 20	AD 19	AD 18	AD 17
F	MCS 16#	S BHE#	IOCS 16#	IO CHK#	IRQ 7	GND	VCC	GND U	VCC U	VCC	GND	VCC	VCC	VCC	GND	AD 16	C/BE 2#	FRM#	I RDY#	T RDY#
G	IRQ6 SLPB	IRQ 5	IRQ 4	IRQ 3	DACK 2#	GND	G7	8	9	10	11	12	13	G14	GND	DEV SEL#	STOP#	SERR#	PAR	CBE1#
H	TC	BALE	DRQ2 SIRQ	IRQ 9	B CLK	VCC	H							H	VCC	AD 15	AD 14	AD 13	AD 12	AD 11
J	RST DRV	LA 23	LA 22	LA 21	LA 20	VCC	J	GND	GND	GND	GND			J	VCC	AD 10	AD 9	AD 8	C/BE 0#	AD 7
K	SA 19	SA 18	IRQ 10	IRQ 11	IRQ 15	VCC	K	GND	GND	GND	GND			K	VCC	AD 6	AD 5	AD 4	AD 3	AD 2
L	IRQ 14	DACK 0#	DRQ 0	DACK 5#	SD 8	GND	L	GND	GND	GND	GND			L	GND	AD 1	AD 0	PREQ#	PGNT#	PD CS1#
M	DRQ 5	SD 9	DACK 6#	SD 10	DRQ 6	VCC	M	GND	GND	GND	GND			M	VCC	PD CS3#	PD A0	PD A2	PD A1	PD DACK#
N	SD 11	DACK 7#	SD 12	DRQ 7	SD 13	VCC	N							N	VCC	PD RDY	PD IOR#	PD IOW#	PD DRQ	PDD 15
P	SD 14	SD 15	SA 17	SA 16	SA15 SDD15	GND	P7	8	9	10	11	12	13	P14	GND	PDD 0	PDD 14	PDD 1	PDD 13	PDD 2
R	SA14 SDD14	SA13 SDD13	SA12 SDD12	SA11 SDD11	SA10 SDD10	GND	VCC	VCC	VCC S	VCC S	VCC	VCC H	GND H	VCC	GND	PDD 12	PDD 3	PDD 11	PDD 4	PDD 10
T	SA9 SDD9	SA8 SDD8	SA7 SDD7	SA6 SDD6	XDIR	INIT	SLP#	GPO 0	SMB DATA	SUS CLK	THRM PME#	FAN 1	VREF	GPIO A	SDD10 JAB2	PDD 5	PDD 9	PDD 6	PDD 8	PDD 7
U	SA5 SDD5	SA4 SDD4	SA3 SDD3	MEM R#	SOE#	SMB#	NMI	GPIO D	SMB CLK	LID	BAT LOW#	FAN 2	V SENS1	SDD7 JBX	SDD5 ACRS	SDD12 JBB2	SD CS1#	SD CS3#	SD A0	SD A2
V	SA2 SDD2	SA1 SDD1	SD 5	MEM W#	SPKR	RSM RST#	FERR#	CPU RST#	SUS A#	SUS ST1#	RING#	PCI STP#	V SENS2	GPIO C	SDD9 JAX	SDD3 SYNC	SDD1 SDI	SD A1	SD DACK#	SD RDY
W	SA0 SDD0	SD 2	SD 4	SD 7	RTC X2	PWR GD	STP CLK#	INTR	SUS B#	SMB ALRT#	IRQ8#	PCK RUN#	T SENS1	V SENS3	SDD6 JBY	SDD11 JAB1	SDD13 JBB1	SDD0 BTCK	SD IOR#	SD IOW#
Y	SD 0	SD 1	SD 3	SD 6	RTC X1	VBAT	A20 M#	IGN NE#	SUS C#	EXT SMI#	PWR BTN#	CPU STP#	T SENS2	V SENS4	SDD8 JAY	SDD4 SDO	SDD2 SDI2	SDD14 MSO	SDD15 MSI	SD DRQ

Note: Some of the pins above have alternate functions and alternate names. The table above contains only one name (usually the most often used function), but the pin lists and pin descriptions contain all names.

**Pin Lists**

**Figure 3. VT82C686A Pin List (Numerical Order)**

Pin	Pin Name	Pin	Pin Name	Pin	Pin Name	Pin	Pin Name	Pin	Pin Name
A01	O SMEMR#	D12	IO IRRX / GPO15	H19	IO AD12	N06	P VCC	U13	I VSENS1 (2.0V)
A02	I IOCHRDY	D13	I PE / WDATA#	H20	IO AD11	N15	P VCC	U14	IO SDD07 / JBX
A03	IO USBP0+	D14	IO PD5	J01	O RSTDRV	N16	I PDRDY	U15	IO SDD05 / RST
A04	IO USBP2+	D15	IO PD1 / TRK00#	J02	IO LA23	N17	O PDIOR#	U16	IO SDD12 / JBB2
A05	IO KBDT / KBRC	D16	IO STROBE#	J03	IO LA22	N18	O PDIOW#	U17	O SDCS1#
A06	I WRTPR#	D17	I PIROB#	J04	IO LA21	N19	I PDDRO	U18	O SDCS3#
A07	O WDATA#	D18	IO AD23	J05	IO LA20	N20	IO PDD15	U19	O SDA0
A08	O DS1#	D19	IO AD22	J06	P VCC	P01	IO SD14	U20	O SDA2
A09	I CTS2#	D20	IO AD21	J09	P GND	P02	IO SD15	V01	IO SA02 / SDD2
A10	I DCD2#	E01	O DACK1# / IDEIROB	J10	P GND	P03	IO SA17	V02	IO SA01 / SDD1
A11	O TXD1	E02	I DRQ1	J11	P GND	P04	IO SA16	V03	IO SD05 / KBIN4
A12	I DCD1#	E03	IO RFSH#	J12	P GND	P05	IO SA15 / SDD15	V04	IO MEMW#
A13	IO PD7	E04	I OSC	J15	P VCC	P06	P GND	V05	IO SPKR
A14	IO PD2 / WRTPR#	E05	IO KBCK/A20GATE	J16	IO AD10	P15	P GND	V06	I RSMRST#
A15	I ERROR#/HDSL#	E06	IO USBP3-	J17	IO AD09	P16	IO PDD00	V07	I FERR#
A16	I PIRQA#	E07	I TRK00#	J18	IO AD08	P17	IO PDD14	V08	OD CPURST
A17	IO AD31	E08	O STEP#	J19	IO CBE0#	P18	IO PDD01	V09	O SUSA# / O1/APD0
A18	IO AD28	E09	O MTR0#	J20	IO AD07	P19	IO PDD13	V10	O SUSST1# / GPO3
A19	IO AD26	E10	O RTS2#	K01	IO SA19	P20	IO PDD02	V11	I RING# / GPI7
A20	IO AD25	E11	I RII#	K02	IO SA18	R01	IO SA14 / SDD14	V12	O PCISTP#/GPO5
B01	O SMEMW#	E12	O IRTX / GPO14	K03	I IRO10	R02	IO SA13 / SDD13	V13	I VSENS2 (2.5V)
B02	O AEN	E13	I SLCT / WGATE#	K04	I IRO11	R03	IO SA12 / SDD12	V14	IO GPIOC(10)/CHAS
B03	IO USBP0-	E14	IO PD6	K05	I IRO15	R04	IO SA11 / SDD11	V15	IO SDD09 / JAX
B04	IO USBP2-	E15	IO SLCTIN# / STEP#	K06	P VCC	R05	IO SA10 / SDD10	V16	IO SDD03 / SYNC
B05	IO USBP3+	E16	I PCLK	K09	P GND	R06	P GND	V17	IO SDD01 / SDI
B06	I RDATA#	E17	IO AD20	K10	P GND	R07	P VCC	V18	O SDA1
B07	O WGATE#	E18	IO AD19	K11	P GND	R08	P VCC	V19	O SDDACK#
B08	O DSO#	E19	IO AD18	K12	P GND	R09	P VCCS	Y20	I SDRDY
B09	O DTR2#	E20	IO AD17	K15	P VCC	R10	P VCCS	W01	IO SA00 / SDD0
B10	I RXD2	F01	I MCS16#	K16	IO AD06	R11	P VCC	W02	IO SD02
B11	O RTS1#	F02	IO SBHE#	K17	IO AD05	R12	P VCC	W03	IO SD04 / KBIN3
B12	I RXD1	F03	I IOCS16#	K18	IO AD04	R13	P GNDH	W04	IO SD07 / KBIN6
B13	I ACK# / DS1#	F04	I IOCHCK# / GPIO	K19	IO AD03	R14	P VCC	W05	O RTCX2
B14	IO PD3 / RDATA#	F05	I IRQ7	K20	IO AD02	R15	P GND	W06	I PWRGD
B15	IO PD0 / INDE#	F06	P GND	L01	I IRO14	R16	IO PDD12	W07	OD STPCLK#
B16	O PCIRST#	F07	P VCC	L02	O DACK0#/IA	R17	IO PDD03	W08	OD INTR
B17	I PIRQD#	F08	P GNDU	L03	I DRQ0	R18	IO PDD11	W09	O SUSB# / GPO2
B18	IO AD29	F09	P VCCU	L04	O DACK5#/MI	R19	IO PDD04	W10	I SMBALRT#/GPI6
B19	IO AD27	F10	P VCC	L05	IO SD08	R20	IO PDD10	W11	I IRQ8#/GPI1
B20	IO AD24	F11	P GND	L06	P GND	T01	IO SA09 / SDD9	W12	IO PCKRUN#
C01	I ROMCS#/KB#	F12	P VCC	L09	P GND	T02	IO SA08 / SDD8	W13	I TSENS1
C02	IO IOW#	F13	P VCC	L10	P GND	T03	IO SA07 / SDD7	W14	I VSENS3 (5V)
C03	I USBCLK	F14	P VCC	L11	P GND	T04	IO SA06 / SDD6	W15	IO SDD06 / JBY
C04	IO USBP1+	F15	P GND	L12	P GND	T05	O XDIR/O12/PCS0#	W16	IO SDD11 / JAB1
C05	IO MSDT / IRQ12	F16	IO AD16	L15	P GND	T06	OD INIT	W17	IO SDD13 / JBB1
C06	I DSKCHG#	F17	IO CBE2#	L16	IO AD01	T07	OD SLP# / GPO7	W18	IO SDD00 / BTCK
C07	O HDSEL#	F18	IO FRAME#	L17	IO AD00	T08	O GPO0 / SLOWCLK	W19	O SDIOR#
C08	O MTR1#	F19	IO IRDY#	L18	O PREQ#	T09	IO SMBDATA	W20	O SDIOW#
C09	I RI2#	F20	IO TRDY#	L19	I PGNT#	T10	O SUSCLK / APICD1	Y01	IO SD00
C10	I DSR2#	G01	I IRO6/14/SLPBTN#	L20	O PDCS1#	T11	I THRM / PME# / GI5	Y02	IO SD01
C11	I CTS1#	G02	I IRO5	M01	I DRQ5	T12	I FAN1	Y03	IO SD03
C12	I DSR1#	G03	I IRQ4	M02	IO SD09	T13	P VREF	Y04	IO SD06 / KBIN5
C13	I BUSY / MTR1#	G04	I IRQ3	M03	O DACK6#/UA	T14	IO GPIOA/8/GPOWE#	Y05	I RTCX1
C14	IO PD4 / DSKCHG#	G05	O DACK2#/I13/O25/OC0#	M04	IO SD10	T15	IO SDD10 / JAB2	Y06	P VBAT
C15	IO PINIT# / DIR#	G06	P GND	M05	I DRQ6	T16	IO PDD05	Y07	OD A20M#
C16	IO AUTOFD#/DRV0	G15	P GND	M06	P VCC	T17	IO PDD09	Y08	OD IGNNE#
C17	I PIRQC#	G16	IO DEVSEL#	M09	P GND	T18	IO PDD06	Y09	O SUSC#
C18	IO AD30	G17	IO STOP#	M10	P GND	T19	IO PDD08	Y10	IOD EXTSMI#
C19	IO CBE3#	G18	I SERR#	M11	P GND	T20	IO PDD07	Y11	I PWRBTN#
C20	I IDSEL	G19	IO PAR	M12	P GND	U01	IO SA05 / SDD5	Y12	O CPUTP#/GPO4
D01	IO IOR#	G20	IO CBE1#	M15	P VCC	U02	IO SA04 / SDD4	Y13	I TSENS2
D02	O DACK3#/ACIRO	H01	O TC	M16	O PDCS3#	U03	IO SA03 / SDD3	Y14	I VSENS4 (12V)
D03	I DRQ3	H02	O BALE	M17	O PDA0	U04	IO MEMR#	Y15	IO SDD08 / JAY
D04	IO USBP1-	H03	I DRQ2/I12/O24/SQ/OC1	M18	O PDA2	U05	O SOE#/O13/MCCS#	Y16	IO SDD04 / SDO
D05	IO MSCK / IRQ1	H04	I IRQ9	M19	O PDA1	U06	OD SMI#	Y17	IO SDD02 / SDI2
D06	O DRVDEN1	H05	O BCLK	M20	O PDDACK#	U07	OD NMI	Y18	IO SDD14 / MSO
D07	I INDE#	H06	P VCC	N01	IO SD11	U08	IO GPIOD/SO#/MCCS#	Y19	IO SDD15 / MSI
D08	O DIR#	H15	P VCC	N02	O DACK7#/UB	U09	IO SMBCLK	Y20	I SDDRO
D09	O DRVDEN0	H16	IO AD15	N03	IO SD12	U10	I LID / GPI3 / WSC#		
D10	O TXD2	H17	IO AD14	N04	I DRQ7	U11	I BATLOW#/GPI2		
D11	O DTR1#	H18	IO AD13	N05	IO SD13	U12	IO FAN2/GPIOB(9)		

Figure 4. VT82C686A Pin List (Alphabetical Order)

Pin	Pin Name	Pin	Pin Name	Pin	Pin Name	Pin	Pin Name	Pin	Pin Name
Y07	OD A20M#	C12	I DSR1#	J04	IO LA21	W05	O RTCX2	T07	OD SLP# / GPO7
B13	I ACK# / DS1#	C10	I DSR2#	J03	IO LA22	B11	O RTS1#	W10	I SMBALRT# / GPI6
L17	IO AD00	D11	O DTR1#	J02	IO LA23	E10	O RTS2#	U09	IO SMBCLK
L16	IO AD01	B09	O DTR2#	U10	I LID/GPI3/WSC#	B12	I RXD1	T09	IO SMBDATA
K20	IO AD02	A15	I ERROR#/HDSEL#	F01	I MCS16#	B10	I RXD2	A01	O SMEMR#
K19	IO AD03	Y10	IOD EXTSMI#	U04	IO MEMR#	W01	IO SA00 / SDD0	B01	O SMEMW#
K18	IO AD04	T12	I FAN1	V04	IO MEMW#	V02	IO SA01 / SDD1	U06	OD SMI#
K17	IO AD05	U12	IO FAN2/GPIOB(9)	D05	IO MSCK / IRO1	V01	IO SA02 / SDD2	U05	O SOE#/GPO13/MCCS#
K16	IO AD06	V07	I FERR#	C05	IO MSDT / IRO12	V03	IO SA03 / SDD3	V05	IO SPKR
J20	IO AD07	F18	IO FRAME#	E09	O MTR0#	U02	IO SA04 / SDD4	E08	O STEP#
J18	IO AD08	<b>F06</b>	<b>P GND</b>	C08	O MTR1#	U01	IO SA05 / SDD5	G17	IO STOP#
J17	IO AD09	<b>F11</b>	<b>P GND</b>	U07	OD NMI	T04	IO SA06 / SDD6	W07	OD STPLCK#
J16	IO AD10	<b>F15</b>	<b>P GND</b>	E04	I OSC	T03	IO SA07 / SDD7	D16	IO STROBE#
H20	IO AD11	<b>G06</b>	<b>P GND</b>	G19	IO PAR	T02	IO SA08 / SDD8	V09	O SUSAN# / O1 / APICD0
H19	IO AD12	<b>G15</b>	<b>P GND</b>	W12	IO PCKRUN#	T01	IO SA09 / SDD9	W09	O SUBS# / GPO2
H18	IO AD13	<b>J09</b>	<b>P GND</b>	E16	I PCLK	R05	IO SA10 / SDD10	Y09	O SUSC#
H17	IO AD14	<b>J10</b>	<b>P GND</b>	B16	O PCIRST#	R04	IO SA11 / SDD11	T10	O SUSCLK / APICD1
H16	IO AD15	<b>J11</b>	<b>P GND</b>	V12	O PCISTP#/GPO5	R03	IO SA12 / SDD12	V10	O SUSST1# / GPO3
F16	IO AD16	<b>J12</b>	<b>P GND</b>	B15	IO PD0 / INDEX#	R02	IO SA13 / SDD13	H01	O TC
E20	IO AD17	<b>K09</b>	<b>P GND</b>	D15	IO PD1 / TRK00#	R01	IO SA14 / SDD14	T11	I THRM / PME# / GI5
E19	IO AD18	<b>K10</b>	<b>P GND</b>	A14	IO PD2 / WRTPR#	P05	IO SA15 / SDD15	F20	IO TRDY#
E18	IO AD19	<b>K11</b>	<b>P GND</b>	B14	IO PD3 / RDATA#	P04	IO SA16	E07	I TRK00#
E17	IO AD20	<b>K12</b>	<b>P GND</b>	C14	IO PD4 / DSKCHG#	P03	IO SA17	W13	I TSNS1
D20	IO AD21	<b>L06</b>	<b>P GND</b>	D14	IO PD5	K02	IO SA18	Y13	I TSNS2
D19	IO AD22	<b>L09</b>	<b>P GND</b>	E14	IO PD6	K01	IO SA19	A11	O TXD1
D18	IO AD23	<b>L10</b>	<b>P GND</b>	A13	IO PD7	F02	IO SBHE#	D10	O TXD2
B20	IO AD24	<b>L11</b>	<b>P GND</b>	M17	O PDA0	Y01	IO SD00	C03	I USBCLK
A20	IO AD25	<b>L12</b>	<b>P GND</b>	M19	O PDA1	Y02	IO SD01	B03	IO USBP0-
A19	IO AD26	<b>L15</b>	<b>P GND</b>	M18	O PDA2	W02	IO SD02	A03	IO USBP0+
B19	IO AD27	<b>M09</b>	<b>P GND</b>	L20	O PDCS1#	Y03	IO SD03	D04	IO USBP1-
A18	IO AD28	<b>M10</b>	<b>P GND</b>	M16	O PDCS3#	W03	IO SD04 / KBIN3	C04	IO USBP1+
B18	IO AD29	<b>M11</b>	<b>P GND</b>	P16	IO PDD00	V03	IO SD05 / KBIN4	B04	IO USBP2-
C18	IO AD30	<b>M12</b>	<b>P GND</b>	P18	IO PDD01	Y04	IO SD06 / KBIN5	A04	IO USBP2+
A17	IO AD31	<b>P06</b>	<b>P GND</b>	P20	IO PDD02	W04	IO SD07 / KBIN6	E06	IO USBP3-
B02	O AEN	<b>P15</b>	<b>P GND</b>	R17	IO PDD03	L05	IO SD08	B05	IO USBP3+
C16	IO AUTOFD#/DR0	<b>R06</b>	<b>P GND</b>	R19	IO PDD04	M02	IO SD09	<b>Y06</b>	<b>P VBAT</b>
H02	O BALE	<b>R15</b>	<b>P GND</b>	T16	IO PDD05	M04	IO SD10	<b>F07</b>	<b>P VCC</b>
U11	I BATLOW#/GPI2	<b>R13</b>	<b>P GNDH</b>	T18	IO PDD06	N01	IO SD11	<b>F10</b>	<b>P VCC</b>
H05	O BCLK	<b>F08</b>	<b>P GNDU</b>	T20	IO PDD07	N03	IO SD12	<b>F12</b>	<b>P VCC</b>
C13	I BUSY / MTR1#	T14	IO GPIOA(8)/GPOWE#	T19	IO PDD08	N05	IO SD13	<b>F13</b>	<b>P VCC</b>
J19	IO CBE0#	V14	IO GPIOC(10)/CHAS	T17	IO PDD09	P01	IO SD14	<b>F14</b>	<b>P VCC</b>
G20	IO CBE1#	U08	IO GPIOD/SO#/MCCS	R20	IO PDD10	P02	IO SD15	<b>H06</b>	<b>P VCC</b>
F17	IO CBE2#	T08	O GPO0 / SLOWCLK	R18	IO PDD11	U19	O SDA0	<b>H15</b>	<b>P VCC</b>
C19	IO CBE3#	C07	O HDSEL#	R16	IO PDD12	V18	O SDA1	<b>J06</b>	<b>P VCC</b>
V08	OD CPURST	C20	I IDSEL	P19	IO PDD13	U20	O SDA2	<b>J15</b>	<b>P VCC</b>
Y12	O CPUSTP#/GPO4	Y08	OD IGNNE#	P17	IO PDD14	U17	O SDCS1#	<b>K06</b>	<b>P VCC</b>
C11	I CTS1#	D07	I INDEX#	N20	IO PDD15	U18	O SDCS3#	<b>K15</b>	<b>P VCC</b>
A09	I CTS2#	T06	OD INIT	M20	O PDDACK#	W18	IO SDD00 / BTCK	<b>M06</b>	<b>P VCC</b>
L02	O DACK0#/IDEA	W08	OD INTR	N19	I PDDR0	V17	IO SDD01 / SDI	<b>M15</b>	<b>P VCC</b>
E01	O DACK1#/IDEB	F04	I IOCHCK# / GPIO	N17	O PDIOR#	Y17	IO SDD02 / SDI2	<b>N06</b>	<b>P VCC</b>
G05	O DACK2#/I13/O25	A02	I IOCHRDY	N18	O PDIOW#	V16	IO SDD03 / SYNC	<b>N15</b>	<b>P VCC</b>
D02	O DACK3#/AIRO	F03	I IOCS16#	N16	I PDRDY	Y16	IO SDD04 / SDO	<b>R07</b>	<b>P VCC</b>
L04	O DACK5#/MIRQ	D01	IO IOR#	D13	I PE / WDATA#	U15	IO SDD05 / RST	<b>R08</b>	<b>P VCC</b>
M03	O DACK6#/USBIA	C02	IO IOW#	L19	I PGNT#	W15	IO SDD06 / JBY	<b>R11</b>	<b>P VCC</b>
N02	O DACK7#/USBIB	F19	IO IRDY#	C15	IO PINIT# / DIR#	U14	IO SDD07 / JBX	<b>R14</b>	<b>P VCC</b>
A12	I DCD1#	G04	I IRO3	A16	I PIROA#	Y15	IO SDD08 / JAY	<b>R12</b>	<b>P VCC</b>
A10	I DCD2#	G03	I IRO4	D17	I PIROB#	V15	IO SDD09 / JAX	<b>R09</b>	<b>P VCCS</b>
G16	IO DEVSEL#	G02	I IRO5	C17	I PIROC#	T15	IO SDD10 / JAB2	<b>R10</b>	<b>P VCCS</b>
D08	O DIR#	G01	I IRO6/14/SLPBTN#	B17	I PIROD#	W16	IO SDD11 / JAB1	<b>F09</b>	<b>P VCCU</b>
L03	I DRO0	F05	I IRO7	L18	O PREO#	U16	IO SDD12 / JBB2	<b>T13</b>	<b>P VREF</b>
E02	I DRO1	W11	I IRO8# / GPI1	Y11	I PWRBTN#	W17	IO SDD13 / JBB1	U13	I VSENS1 (2.0V)
H03	I D2/I12/O24/SQ	H04	I IRQ9	W06	I PWRGD	Y18	IO SDD14 / MSO	V13	I VSENS2 (2.2V)
D03	I DRQ3	K03	I IRQ10	B06	I RDATA#	Y19	IO SDD15 / MSI	W14	I VSENS3 (5V)
M01	I DRO5	K04	I IRO11	E03	IO RFSH#	V19	O SDDACK#	Y14	I VSENS4 (12V)
M05	I DRO6	L01	I IRO14	E11	I RII#	Y20	I SDDRQ	A07	O WDATA#
N04	I DRO7	K05	I IRO15	C09	I RI2#	W19	O SDIOR#	B07	O WGATE#
D09	O DRVDEN0	D12	IO IRRX / GPO15	V11	I RING# / GPI7	W20	O SDIOW#	A06	I WRTPR#
D06	O DRVDEN1	E12	O IRTX / GPO14	C01	O ROMCS#/KBCS#	V20	I SDRDY	T05	O XDIR/GPO12/PCS0#
B08	O DS0#	E05	IO KBACK / A20GATE	V06	I RSMRST#	G18	I SERR#		
A08	O DS1#	A05	IO KBDT / KBRC	J01	O RSTDRV	E13	I SLCT / WGATE#		
C06	I DSKCHG#	J05	IO LA20	Y05	I RTCX1	E15	IO SLCTIN#/STEP#		



Pin Descriptions

Table 1. Pin Descriptions

PCI Bus Interface																												
Signal Name	Pin #	I/O	Signal Description																									
AD[31:0]	(see pin list)	IO	<b>Address/Data Bus.</b> The standard PCI address and data lines. The address is driven with FRAME# assertion and data is driven or received in following cycles.																									
C/BE[3:0]#	C19, F17, G20, J19	IO	<b>Command/Byte Enable.</b> The command is driven with FRAME# assertion. Byte enables corresponding to supplied or requested data are driven on following clocks.																									
FRAME#	F18	IO	<b>Frame.</b> Assertion indicates the address phase of a PCI transfer. Negation indicates that one more data transfer is desired by the cycle initiator.																									
IRDY#	F19	IO	<b>Initiator Ready.</b> Asserted when the initiator is ready for data transfer.																									
TRDY#	F20	IO	<b>Target Ready.</b> Asserted when the target is ready for data transfer.																									
STOP#	G17	IO	<b>Stop.</b> Asserted by the target to request the master to stop the current transaction.																									
DEVSEL#	G16	IO	<b>Device Select.</b> The VT82C686A asserts this signal to claim PCI transactions through positive or subtractive decoding. As an input, DEVSEL# indicates the response to a VT82C686A-initiated transaction and is also sampled when decoding whether to subtractively decode the cycle.																									
PAR	G19	IO	<b>Parity.</b> A single parity bit is provided over AD[31:0] and C/BE[3:0]#.																									
SERR#	G18	I	<b>System Error.</b> SERR# can be pulsed active by any PCI device that detects a system error condition. Upon sampling SERR# active, the VT82C686A can be programmed to generate an NMI to the CPU.																									
IDSEL	C20	I	<b>Initialization Device Select.</b> IDSEL is used as a chip select during configuration read and write cycles. Connect this pin to AD18 using a 100 Ω resistor.																									
PIRQA-D#	A16, D17, C17, B17	I	<p><b>PCI Interrupt Request.</b> These pins are typically connected to the PCI bus INTA#-INTD# pins as follows:</p> <table border="0" style="margin-left: 40px;"> <tr> <td></td> <td><u>PIRQA#</u></td> <td><u>PIROB#</u></td> <td><u>PIROC#</u></td> <td><u>PIROD#</u></td> </tr> <tr> <td>PCI Slot 1</td> <td>INTA#</td> <td>INTB#</td> <td>INTC#</td> <td>INTD#</td> </tr> <tr> <td>PCI Slot 2</td> <td>INTB#</td> <td>INTC#</td> <td>INTD#</td> <td>INTA#</td> </tr> <tr> <td>PCI Slot 3</td> <td>INTC#</td> <td>INTD#</td> <td>INTA#</td> <td>INTB#</td> </tr> <tr> <td>PCI Slot 4</td> <td>INTD#</td> <td>INTA#</td> <td>INTB#</td> <td>INTC#</td> </tr> </table>		<u>PIRQA#</u>	<u>PIROB#</u>	<u>PIROC#</u>	<u>PIROD#</u>	PCI Slot 1	INTA#	INTB#	INTC#	INTD#	PCI Slot 2	INTB#	INTC#	INTD#	INTA#	PCI Slot 3	INTC#	INTD#	INTA#	INTB#	PCI Slot 4	INTD#	INTA#	INTB#	INTC#
	<u>PIRQA#</u>	<u>PIROB#</u>	<u>PIROC#</u>	<u>PIROD#</u>																								
PCI Slot 1	INTA#	INTB#	INTC#	INTD#																								
PCI Slot 2	INTB#	INTC#	INTD#	INTA#																								
PCI Slot 3	INTC#	INTD#	INTA#	INTB#																								
PCI Slot 4	INTD#	INTA#	INTB#	INTC#																								
PREQ#	L18	O	<b>PCI Request.</b> This signal goes to the North Bridge to request the PCI bus.																									
PGNT#	L19	I	<b>PCI Grant.</b> This signal is driven by the North Bridge to grant PCI access to the VT82C686A.																									
PCLK	E16	I	<b>PCI Clock.</b> PCLK provides timing for all transactions on the PCI Bus.																									
PCKRUN#	W12	IO	<b>PCI Bus Clock Run.</b> This signal indicates whether the PCI clock is or will be stopped (high) or running (low). The VT82C686A drives this signal low when the PCI clock is running (default on reset) and releases it when it stops the PCI clock. External devices may assert this signal low to request that the PCI clock be restarted or prevent it from stopping. Connect this pin to ground using a 100 Ω resistor if the function is not used. Refer to the “PCI Mobile Design Guide” and the VIA “Apollo MVP4 Design Guide” for more details.																									
PCIRST#	B16	O	<b>PCI Reset.</b> Active low reset signal for the PCI bus. The VT82C686A will assert this pin during power-up or from the control register.																									

CPU Interface			
Signal Name	Pin #	I/O	Signal Description
CPURST	V8	OD	<b>CPU Reset.</b> The VT82C686A asserts CPURST to reset the CPU during power-up.
INTR	W8	OD	<b>CPU Interrupt.</b> INTR is driven by the VT82C686A to signal the CPU that an interrupt request is pending and needs service.
NMI	U7	OD	<b>Non-Maskable Interrupt.</b> NMI is used to force a non-maskable interrupt to the CPU. The VT82C686A generates an NMI when either SERR# or IOCHK# is asserted.
INIT	T6	OD	<b>Initialization.</b> The VT82C686A asserts INIT if it detects a shut-down special cycle on the PCI bus or if a soft reset is initiated by the register
STPCLK#	W7	OD	<b>Stop Clock.</b> STPCLK# is asserted by the VT82C686A to the CPU to throttle the processor clock.
SMI#	U6	OD	<b>System Management Interrupt.</b> SMI# is asserted by the VT82C686A to the CPU in response to different Power-Management events.
FERR#	V7	I	<b>Numerical Coprocessor Error.</b> This signal is tied to the coprocessor error signal on the CPU. Internally generates interrupt 13 if active.
IGNNE#	Y8	OD	<b>Ignore Numeric Error.</b> This pin is connected to the “ignore error” pin on the CPU.
SLP# / GPO7	T7	OD	<b>Sleep</b> (Rx75[7] = 0). Used to put the CPU to sleep. Used with slot-1 CPUs only. Not currently used with socket-7 CPUs.
A20M#	Y7	OD	<b>A20 Mask.</b> Connect to A20 mask input of the CPU to control address bit-20 generation. Logical combination of the A20GATE input (from internal or external keyboard controller) and Port 92 bit-1 (Fast_A20).

Note: Connect each of the above signals to 4.7K  $\Omega$  pullup resistors to VCC3.

Advanced Programmable Interrupt Controller (APIC)			
Signal Name	Pin #	I/O	Signal Description
WSC# (CG) / GPI3 / LID	U10	I / I / I	<b>Write Snoop Complete.</b> Asserted by the north bridge to indicate that all snoop activity on the CPU bus initiated by the last PCI-to-DRAM write is complete and that it is safe to perform an APIC interrupt. Pin U10 is WSC# if Rx74[7]=1.
APICD0 (CG) / GPO1 / SUSA#	V9	IO / O / O	<b>APIC Data 0.</b> Rx74[7]=1.
APICD1 (CG) / SUSCLK	T10	IO / O	<b>APIC Data 1.</b> Rx74[7]=1.

For programming information, refer to Function 0 Rx74,77, Function 4 Rx54[3-2], and Memory Mapped / Indexed APIC registers.



Universal Serial Bus Interface			
Signal Name	Pin #	I/O	Signal Description
USBP0+	A3	IO	USB Port 0 Data +
USBP0-	B3	IO	USB Port 0 Data -
USBP1+	C4	IO	USB Port 1 Data +
USBP1-	D4	IO	USB Port 1 Data -
USBP2+	A4	IO	USB Port 2 Data +
USBP2-	B4	IO	USB Port 2 Data -
USBP3+	B5	IO	USB Port 3 Data +
USBP3-	E6	IO	USB Port 3 Data -
USBCLK	C3	I	USB Clock. 48MHz clock input for the USB interface
USBOC0# / GPI13 / GPO25 / DACK2# / FDCIRQ	G5	I / I / O O / I	USB Port 0 Over Current Detect. Port 0 is disabled if low.
USBOC1# / GPI12 / GPO24 / DRQ2 / FDCDRQ / SERIRQ	H3	I / I / O I / I / I	USB Port 1 Over Current Detect. Port 1 is disabled if this input is low. Direct inputs are provided for overcurrent protection for ports 0 and 1 which may be used if the alternate functions of these two pins are not required. If overcurrent protection is desired on all four ports (or it is desired to use the alternate functions of these two pins), an external buffer may be used to drive the state of USBOC[3-0]# onto SD[3-0] during ISA bus refresh cycles (i.e., while ISA bus RFSH# is low, so that RFSH# may be used as the buffer enable).
USBOC0# (SD2 & RFSH#)	(W2)	I	USB Port 0 Over Current Detect
USBOC1# (SD1 & RFSH#)	(Y2)	I	USB Port 1 Over Current Detect
USBOC2# (SD0 & RFSH#)	(Y1)	I	USB Port 2 Over Current Detect
USBOC3# (SD3 & RFSH#)	(Y3)	I	USB Port 3 Over Current Detect
USBIRQA / DACK6#	M3	O	USB Interrupt Request A. Output of internal block.
USBIRQB / DACK7#	N2	O	USB Interrupt Request B. Output of internal block.

System Management Bus (SMB) Interface (I <sup>2</sup> C Bus)			
Signal Name	Pin #	I/O	Signal Description
SMBCLK	U9	IO	SMB / I <sup>2</sup> C Clock.
SMBDATA	T9	IO	SMB / I <sup>2</sup> C Data.
SMBALRT# / GPI6	W10	I	SMB Alert. (System Management Bus I/O space Rx08[3] = 1) When the chip is enabled to allow it, assertion generates an IRQ or SMI interrupt or a power management resume event. The same pin is used as General Purpose Input 6 whose value is reflected in Rx48[6] of function 4 I/O space

UltraDMA-33 / 66 Enhanced IDE Interface			
Signal Name	Pin #	I/O	Signal Description
<b>PDRDY / PDDMARDY / PDSTROBE</b>	N16	I	EIDE Mode: <b>Primary I/O Channel Ready.</b> Device ready indicator UltraDMA Mode: <b>Primary Device DMA Ready.</b> Output flow control. The device may assert DDMARDY to pause output transfers <b>Primary Device Strobe.</b> Input data strobe (both edges). The device may stop DSTROBE to pause input data transfers
<b>SDRDY / SDDMARDY / SDSTROBE</b>	V20	I	EIDE Mode: <b>Secondary I/O Channel Ready.</b> Device ready indicator UltraDMA Mode: <b>Secondary Device DMA Ready.</b> Output flow control. The device may assert DDMARDY to pause output transfers <b>Secondary Device Strobe.</b> Input data strobe (both edges). The device may stop DSTROBE to pause input data transfers
<b>PDIOR# / PHDMARDY / PHSTROBE</b>	N17	O	EIDE Mode: <b>Primary Device I/O Read.</b> Device read strobe UltraDMA Mode: <b>Primary Host DMA Ready.</b> Primary channel input flow control. The host may assert HDMARDY to pause input transfers <b>Primary Host Strobe.</b> Output data strobe (both edges). The host may stop HSTROBE to pause output data transfers
<b>SDIOR# / SHDMARDY / SHSTROBE</b>	W19	O	EIDE Mode: <b>Secondary Device I/O Read.</b> Device read strobe UltraDMA Mode: <b>Secondary Host DMA Ready.</b> Input flow control. The host may assert HDMARDY to pause input transfers <b>Host Strobe B.</b> Output strobe (both edges). The host may stop HSTROBE to pause output data transfers
<b>PDIOW# / PSTOP</b>	N18	O	EIDE Mode: <b>Primary Device I/O Write.</b> Device write strobe UltraDMA Mode: <b>Primary Stop.</b> Stop transfer: Asserted by the host prior to initiation of an UltraDMA burst; negated by the host before data is transferred in an UltraDMA burst. Assertion of STOP by the host during or after data transfer in UltraDMA mode signals the termination of the burst.
<b>SDIOW# / SSTOP</b>	W20	O	EIDE Mode: <b>Secondary Device I/O Write.</b> Device write strobe UltraDMA Mode: <b>Secondary Stop.</b> Stop transfer: Asserted by the host prior to initiation of an UltraDMA burst; negated by the host before data is transferred in an UltraDMA burst. Assertion of STOP by the host during or after data transfer in UltraDMA mode signals the termination of the burst.
<b>PDDRQ</b>	N19	I	<b>Primary Device DMA Request.</b> Primary channel DMA request
<b>SDDRQ</b>	Y20	I	<b>Secondary Device DMA Request.</b> Secondary channel DMA request
<b>PDDACK#</b>	M20	O	<b>Primary Device DMA Acknowledge.</b> Primary channel DMA acknowledge
<b>SDDACK#</b>	V19	O	<b>Secondary Device DMA Acknowledge.</b> Secondary channel DMA acknowledge

UltraDMA-33 / 66 Enhanced IDE Interface (continued)			
Signal Name	Pin #	I/O	Signal Description
PDCS1#	L20	O	<b>Primary Master Chip Select.</b> This signal corresponds to CS1FX# on the primary IDE connector.
PDCS3#	M16	O	<b>Primary Slave Chip Select.</b> This signal corresponds to CS3FX# on the primary IDE connector.
SDCS1#	U17	O	<b>Secondary Master Chip Select.</b> This signal corresponds to CS17X# on the secondary IDE connector.
SDCS3#	U18	O	<b>Secondary Slave Chip Select.</b> This signal corresponds to CS37X# on the secondary IDE connector.
PDA[2-0]	M18, M19, M17	O	<b>Primary Disk Address.</b> PDA[2:0] are used to indicate which byte in either the ATA command block or control block is being accessed.
SDA[2-0]	U20, V18, U19	O	<b>Secondary Disk Address.</b> SDA[2:0] are used to indicate which byte in either the ATA command block or control block is being accessed.
PDD[15-0]	N20, P17, P19, R16, R18, R20, T17, T19, T20, T18, T16, R19, R17, P20, P18, P16	IO	<b>Primary Disk Data</b>
SDD[15-0] / SA[15-0]	P5, R1-R5, T1-T4, U1-U3, V1, V2, W1	IO	<b>Secondary Disk Data</b> muxed with ISA Bus Address (Audio Enabled) <b>ISA Bus Address only</b> (Audio Disabled / Dedicated Secondary IDE Data) Note: Audio is enabled by strapping the SPKR pin high with 4.7K ohms and disabled by strapping the SPKR pin low with 4.7K ohms.
SDD[15] / MSI, SDD[14] / MSO, SDD[13] / JBB1 / PDRQB, SDD[12] / JBB2 / PGNTB, SDD[11] / JAB1 / PDRQA, SDD[10] / JAB2 / PGNTA, SDD[9] / JAX / GPO23, SDD[8] / JAY / GPO22, SDD[7] / JBX / GPI23, SDD[6] / JBY / GPI22, SDD[5] / ACRST, SDD[4] / SDOUT, SDD[3] / SYNC, SDD[2] / SDIN2, SDD[1] / SDIN, SDD[0] / BITCLK	Y19, Y18, W17, U16, W16, T15, V15, Y15, U14, W15, U15, Y16, V16, Y17, V17, W18	IO / I IO / O IO / I IO / I IO / I IO / I IO / I IO / I IO / I IO / I IO / O IO / O IO / O IO / I IO / I IO / I	<b>Secondary Disk Data</b> (SPKR strap = 0) <b>or</b> <b>AC-Link/Game Ports</b> (SPKR strap = 1) <b>Secondary Disk Data 15 / Midi Serial In</b> <b>Secondary Disk Data 14 / Midi Serial Out</b> <b>Secondary Disk Data 13 / Game Port Joystick B Button 1</b> <b>Secondary Disk Data 12 / Game Port Joystick B Button 2</b> <b>Secondary Disk Data 11 / Game Port Joystick A Button 1</b> <b>Secondary Disk Data 10 / Game Port Joystick A Button 2</b> <b>Secondary Disk Data 9 / Game Port Joystick A X-axis</b> <b>Secondary Disk Data 8 / Game Port Joystick A Y-axis</b> <b>Secondary Disk Data 7 / Game Port Joystick B X-axis</b> <b>Secondary Disk Data 6 / Game Port Joystick B Y-axis</b> <b>Secondary Disk Data 5 / AC97 Reset</b> <b>Secondary Disk Data 4 / AC97 Serial Data Out</b> <b>Secondary Disk Data 3 / AC97 Sync</b> <b>Secondary Disk Data 2 / AC97 Serial Data In 2</b> <b>Secondary Disk Data 1 / AC97 Serial Data In</b> <b>Secondary Disk Data 0 / AC97 Bit Clock</b>
IDEIRQA / DACK0#	L2	O	<b>IDE Interrupt Request A.</b> Output of internal block.
IDEIRQB / DACK1#	E1	O	<b>IDE Interrupt Request B.</b> Output of internal block.

MIDI Interface			
Signal Name	Pin #	I/O	Signal Description
MSI / SDD[15]	Y19	I / IO	MIDI Serial In / Secondary Disk Data 15 (SPKR strap = 1)
MSO / SDD[14]	Y18	O / IO	MIDI Serial Out / Secondary Disk Data 14 (SPKR strap = 1)

AC97 Audio / Modem Interface			
Signal Name	Pin #	I/O	Signal Description
ACRST / SDD[5]	U15	O / IO	AC97 Reset / Secondary Disk Data 5 (SPKR strap = 1)
SDOUT / SDD[4]	Y16	O / IO	AC97 Serial Data Out / Secondary Disk Data 4 (SPKR strap = 1)
SYNC / SDD[3]	V16	O / IO	AC97 Sync / Secondary Disk Data 3 (SPKR strap = 1)
SDIN2 / SDD[2]	Y17	I / IO	AC97 Serial Data In 2 / Secondary Disk Data 2 (SPKR strap = 1)
SDIN / SDD[1]	V17	I / IO	AC97 Serial Data In / Secondary Disk Data 1 (SPKR strap = 1)
BITCLK / SDD[0]	W18	I / IO	AC97 Bit Clock / Secondary Disk Data 0 (SPKR strap = 1)
AC97IRQ / DACK3#	D2	O	AC97 Interrupt Request. Output of internal block.
MC97IRQB / DACK5#	L4	O	MC97 Interrupt Request. Output of internal block.

Game Port Interface			
Signal Name	Pin #	I/O	Signal Description
JAB1 / SDD[11] / PDRQA	W16	I / IO / I	Joystick A Button 1 / Secondary Disk Data 11 (SPKR strap = 1)
JAB2 / SDD[10] / PGNTA	T15	I / IO / O	Joystick A Button 2 / Secondary Disk Data 10 (SPKR strap = 1)
JBB1 / SDD[13] / PDRQB	W17	I / IO / I	Joystick B Button 1 / Secondary Disk Data 13 (SPKR strap = 1)
JBB2 / SDD[12] / PGNTB	U16	I / IO / O	Joystick B Button 2 / Secondary Disk Data 12 (SPKR strap = 1)
JAX / SDD[9] / GPO23	V15	I / IO / O	Joystick A X-axis / Secondary Disk Data 9 (SPKR strap = 1)
JAY / SDD[8] / GPO22	Y15	I / IO / O	Joystick A Y-axis / Secondary Disk Data 8 (SPKR strap = 1)
JBX / SDD[7] / GPI23	U14	I / IO / I	Joystick B X-axis / Secondary Disk Data 7 (SPKR strap = 1)
JBY / SDD[6] / GPI22	W15	I / IO / I	Joystick B Y-axis / Secondary Disk Data 6 (SPKR strap = 1)

See Function 0 Rx77[6]

PDRQ / PGNT Interface			
Signal Name	Pin #	I/O	Signal Description
PDRQA / SDD[11] / JAB1	W16	I / IO / I	
PGNTA / SDD[10] / JAB2	T15	O / IO / I	
PDRQB / SDD[13] / JBB1	W17	I / IO / I	
PGNTB / SDD[12] / JBB2	U16	O / IO / I	

Floppy Disk Interface			
Signal Name	Pin #	I/O	Signal Description
<b>DRVDEN0</b>	D9	O	<b>Drive Density Select 0.</b>
<b>DRVDEN1</b>	D6	O	<b>Drive Density Select 1.</b>
<b>MTR0#</b>	E9	O	<b>Motor Control 0.</b> Select motor on drive 0.
<b>MTR1#</b>	C8	O	<b>Motor Control 1.</b> Select motor on drive 1
<b>DS0#</b>	B8	O	<b>Drive Select 0.</b> Select drive 0.
<b>DS1#</b>	A8	O	<b>Drive Select 1.</b> Select drive 1
<b>DIR#</b>	D8	O	<b>Direction.</b> Direction of head movement (0 = inward motion, 1 = outward motion)
<b>STEP#</b>	E8	O	<b>Step.</b> Low pulse for each track-to-track movement of the head.
<b>INDEX#</b>	D7	I	<b>Index.</b> Sense to detect that the head is positioned over the beginning of a track
<b>HDSEL#</b>	C7	O	<b>Head Select.</b> Selects the side for R/W operations (0 = side 1, 1 = side 0)
<b>TRK00#</b>	E7	I	<b>Track 0.</b> Sense to detect that the head is positioned over track 0.
<b>RDATA#</b>	B6	I	<b>Read Data.</b> Raw serial bit stream from the drive for read operations.
<b>WDATA#</b>	A7	O	<b>Write Data.</b> Encoded data to the drive for write operations.
<b>WGATE#</b>	B7	O	<b>Write Gate.</b> Signal to the drive to enable current flow in the write head.
<b>DSKCHG#</b>	C6	I	<b>Disk Change.</b> Sense that the drive door is open or the diskette has been changed since the last drive selection.
<b>WRTPRT#</b>	A6	I	<b>Write Protect.</b> Sense for detection that the diskette is write protected (causes write commands to be ignored)
<b>FDCIRQ / DACK2#</b>	G5	I	<b>FDC Interrupt Request.</b> Rx75[3] = 1.
<b>FDCDRQ / DRQ2</b>	H3	I	<b>FDC DMA Request.</b> Rx75[3] = 1.

Parallel Port Interface			
Signal Name	Pin #	I/O	Signal Description
<b>PINIT# / DIR#</b>	C15	IO / O	<b>Initialize.</b> Initialize printer. Output in standard mode, I/O in ECP/EPP mode.
<b>STROBE# / nc</b>	D16	IO / -	<b>Strobe.</b> Output used to strobe data into the printer. I/O in ECP/EPP mode.
<b>AUTOFD# / DRVEN0</b>	C16	IO / O	<b>Auto Feed.</b> Output used to cause the printer to automatically feed one line after each line is printed. I/O pin in ECP/EPP mode.
<b>SLCTIN# / STEP#</b>	E15	IO / O	<b>Select In.</b> Output used to select the printer. I/O pin in ECP/EPP mode.
<b>SLCT / WGATE#</b>	E13	I / O	<b>Select.</b> Status output from the printer. High indicates that it is powered on.
<b>ACK# / DS1#</b>	B13	I / O	<b>Acknowledge.</b> Status output from the printer. Low indicates that it has received the data and is ready to accept new data
<b>ERROR# / HDSEL#</b>	A15	I / O	<b>Error.</b> Status output from the printer. Low indicates an error condition in the printer.
<b>BUSY / MTR1#</b>	C13	I / O	<b>Busy.</b> Status output from the printer. High indicates not ready to accept data.
<b>PE / WDATA#</b>	D13	I / O	<b>Paper End.</b> Status output from the printer. High indicates that it is out of paper.
<b>PD7 / nc,</b> <b>PD6 / nc,</b> <b>PD5 / nc,</b> <b>PD4 / DSKCHG#,</b> <b>PD3 / RDATA#,</b> <b>PD2 / WRTprt#,</b> <b>PD1 / TRK00#,</b> <b>PD0 / INDEX#</b>	A13, E14, D14, C14, B14, A14, D15, B15	IO / - IO / - IO / - IO / I IO / I IO / I IO / I IO / I	<b>Parallel Port Data.</b>

As shown by the alternate functions above, in mobile applications the parallel port pins in chip version CF and CG can optionally be selected to function as a floppy disk interface for attachment of an external floppy drive using the parallel port connector (see Super I/O Configuration Index F6[5]).

<b>Serial Ports and Infrared Interface</b>			
<b>Signal Name</b>	<b>Pin #</b>	<b>I/O</b>	<b>Signal Description</b>
<b>TXD1</b>	A11	O	<b>Transmit Data 1.</b> Serial port 1 transmit data out.
<b>TXD2</b>	D10	O	<b>Transmit Data 2.</b> Serial port 2 transmit data out.
<b>IRTX / GPO14</b>	E12	O	<b>Infrared Transmit.</b> IR transmit data out (Rx76[5] = 0) from serial port 2. General Purpose Output 14 if Rx76[5] = 1
<b>RXD1</b>	B12	I	<b>Receive Data 1.</b> Serial port 1 receive data in.
<b>RXD2</b>	B10	I	<b>Receive Data 2.</b> Serial port 2 receive data in.
<b>IRRX / GPO15</b>	D12	IO	<b>Infrared Receive.</b> IR receive data in (Rx76[5] = 0) to serial port 2. General Purpose Output 15 if Rx76[5] = 1
<b>RTS1#</b>	B11	O	<b>Request To Send 1.</b> Indicator that serial output port 1 is ready to transmit data. Typically used as hardware handshake with CTS1# for low level flow control. Designed for direct input to external RS-232C driver.
<b>RTS2##</b>	E10	O	<b>Request To Send 2.</b> Indicator that serial output port 2 is ready to transmit data. Typically used as hardware handshake with CTS2# for low level flow control. Designed for direct input to external RS-232C driver.
<b>CTS1#</b>	C11	I	<b>Clear To Send 1.</b> Indicator to serial port 1 that external communications device is ready to receive data. Typically used as hardware handshake with RTS1# for low level flow control. Designed for input from external RS-232C receiver.
<b>CTS2#</b>	A9	I	<b>Clear To Send 2.</b> Indicator to serial port 2 that external communications device is ready to receive data. Typically used as hardware handshake with RTS2# for low level flow control. Designed for input from external RS-232C receiver.
<b>DTR1#</b>	D11	O	<b>Data Terminal Ready 1.</b> Serial port 1 indicator that port is powered, initialized, and ready. Typically used as hardware handshake with DSR1# for overall readiness to communicate. Designed for direct input to external RS-232C driver.
<b>DTR2#</b>	B9	O	<b>Data Terminal Ready 2.</b> Serial port 2 indicator that port is powered, initialized, and ready. Typically used as hardware handshake with DSR2# for overall readiness to communicate. Designed for direct input to external RS-232C driver.
<b>DSR1#</b>	C12	I	<b>Data Set Ready 1.</b> Indicator to serial port 1 that external serial communications device is powered, initialized, and ready. Typically used as hardware handshake with DTR1# for overall readiness to communicate. Designed for direct input from external RS-232C receiver.
<b>DSR2#</b>	C10	I	<b>Data Set Ready 2.</b> Indicator to serial port 2 that external serial communications device is powered, initialized, and ready. Typically used as hardware handshake with DTR2# for overall readiness to communicate. Designed for direct input from external RS-232C receiver.
<b>DCD1#</b>	A12	I	<b>Data Carrier Detect 1.</b> Indicator to serial port 1 that external modem is detecting a carrier signal (i.e., a communications channel is currently open). In direct connect environments, this input will typically be driven by DTR1# as part of the DTR/DSR handshake. Designed for direct input from external RS-232C receiver.
<b>DCD2#</b>	A10	I	<b>Data Carrier Detect 2.</b> Indicator to serial port 2 that external modem is detecting a carrier signal (i.e., a communications channel is currently open). In direct connect environments, this input will typically be driven by DTR2# as part of the DTR/DSR handshake. Designed for direct input from external RS-232C receiver.
<b>RI1#</b>	E11	I	<b>Ring Indicator 1.</b> Indicator to serial port 1 that external modem is detecting a ring condition. Used by software to initiate operations to answer and open the communications channel. Designed for direct input from external RS-232C receiver (whose input is typically not connected in direct connect environments).
<b>RI2#</b>	C9	I	<b>Ring Indicator 2.</b> Indicator to serial port 2 that external modem is detecting a ring condition. Used by software to initiate operations to answer and open the communications channel. Designed for direct input from external RS-232C receiver (whose input is typically not connected in direct connect environments).



<b>ISA Bus Interface</b>			
<b>Signal Name</b>	<b>Pin #</b>	<b>I/O</b>	<b>Signal Description</b>
<b>SA[19:16], SA[15-0] / SDD[15-0]</b>	K1, K2, P3, P4, P5, R1, R2, R3, R4, R5, T1, T2, T3, T4, U1, U2, U3, V1, V2, W1	IO IO	<b>System Address Bus.</b> SA[19-16] are connected to ISA bus SA[19-16] directly. SA[19-17] are also connected to LA[19-17] of the ISA bus. If the audio interface is <u>disabled</u> (SPKR pin strapped low), SA[15-0] are connected directly to ISA address bus pins SA[15-0] (the audio interface pins are used for the IDE secondary data bus). If the audio interface is <u>enabled</u> (SPKR pin strapped high), SA[15-0] are multiplexed with the IDE Secondary Data Bus. In this case, SA[15-0] may be connected to both SDD[15-0] and ISA bus SA[15-0]. However, if ISA address bus loading is a concern, 74F245 transceivers may be used to externally drive ISA address bus pins SA[15-0]. In this case, these pins would connect directly to the IDE secondary data bus and to the transceiver "A" pins and the ISA address bus would connect to the transceiver "B" pins. SOE# would be used to control the transceiver output enables and the ISA bus MASTER# signal would drive the transceiver direction controls.
<b>LA[23:20]</b>	J2, J3, J4, J5	IO	<b>System "Latched" Address Bus:</b> The LA[23:20] address lines are bi-directional. These address lines allow accesses to physical memory on the ISA bus up to 16Mbytes. LA[19-17] on the ISA bus are connected to SA[19-17] (see notes above).
<b>SD[15:0]</b>	P2, P1, N5, N3, N1, M4, M2, L5, W4, Y4, V3, W3, Y3, W2, Y2, Y1	IO	<b>System Data.</b> SD[15:0] provide the data path for devices residing on the ISA bus. X-Bus data signals XD[7:0] may be derived if needed from SD[7:0] using an external 74F245-type transceiver (see the XDIR pin description for transceiver connection details). SD7:4 are strap options for keyboard inputs 6:3 (see Function 0 Rx5A)
<b>SBHE#</b>	F2	IO	<b>System Byte High Enable.</b> SBHE# indicates, when asserted, that a byte is being transferred on the upper byte (SD[15:8]) of the data bus. SBHE# is negated during refresh cycles.
<b>IOR#</b>	D1	IO	<b>I/O Read.</b> IOR# is the command to an ISA I/O slave device that the slave may drive data on to the ISA data bus.
<b>IOW#</b>	C2	IO	<b>I/O Write.</b> IOW# is the command to an ISA I/O slave device that the slave may latch data from the ISA data bus.
<b>MEMR#</b>	U4	IO	<b>Memory Read.</b> MEMR# is the command to a memory slave that it may drive data onto the ISA data bus.
<b>MEMW#</b>	V4	IO	<b>Memory Write.</b> MEMW# is the command to a memory slave that it may latch data from the ISA data bus.
<b>SMEMR#</b>	A1	O	<b>Standard Memory Read.</b> SMEMR# is the command to a memory slave, under 1MB, which indicates that it may drive data onto the ISA data bus
<b>SMEMW#</b>	B1	O	<b>Standard Memory Write.</b> SMEMW# is the command to a memory slave, under 1MB, which indicates that it may latch data from the ISA data bus.
<b>BALE</b>	H2	O	<b>Bus Address Latch Enable.</b> BALE is an active high signal asserted by the VT82C686A to indicate that the address (SA[19:0], LA[23:17] and the SBHE# signal) is valid
<b>IOCS16#</b>	F3	I	<b>16-Bit I/O Chip Select.</b> This signal is driven by I/O devices on the ISA Bus to indicate that they support 16-bit I/O bus cycles.
<b>MCS16#</b>	F1	I	<b>Memory Chip Select 16.</b> ISA slaves that are 16-bit memory devices drive this line low to indicate they support 16-bit memory bus cycles.
<b>IOCHCK# / GPIO</b>	F4	I	<b>I/O Channel Check</b> (Rx74[0] = 1). When this signal is asserted, it indicates that a parity or an uncorrectable error has occurred for an I/O or memory device on the ISA Bus. The same pin may optionally be used as General Purpose Input 0.
<b>IOCHRDY</b>	A2	I	<b>I/O Channel Ready</b> (Rx74[0] = 1). This signal is normally high. Devices on the ISA Bus assert IOCHRDY low to indicate that additional time (wait states) is required to complete the cycle.
<b>AEN</b>	B2	O	<b>Address Enable.</b> AEN is asserted during DMA cycles to prevent I/O slaves from misinterpreting DMA cycles as valid I/O cycles.



ISA Bus Interface (continued)			
Signal Name	Pin #	I/O	Signal Description
RFSH#	E3	IO	<b>Refresh.</b> Indicates when a refresh cycle is in progress. Also driven by 16-bit ISA Bus masters to indicate a refresh cycle.
IRQ1 / MSCK	D5	I / IO	<b>Interrupt Request 1</b> (Rx5A[1] = 0)
IRQ3	G4	I	<b>Interrupt Request 3.</b>
IRQ4	G3	I	<b>Interrupt Request 4.</b>
IRQ5	G2	I	<b>Interrupt Request 5.</b>
IRQ6 / GPI4 / SLPBTN#	G1	I / I / I	<b>Interrupt Request 6.</b>
IRQ7	F5	I	<b>Interrupt Request 7.</b>
IRQ8# / GPI1	W11	I / I	<b>Interrupt Request 8</b> from ext RTC if int RTC disabled (Rx5A[2] = 0)
IRQ9	H4	I	<b>Interrupt Request 9.</b>
IRQ10	K3	I	<b>Interrupt Request 10.</b>
IRQ11	K4	I	<b>Interrupt Request 11.</b>
IRQ12 / MSDT	C5	I / IO	<b>Interrupt Request 12.</b> (Rx5A[1] = 0)
IRQ14	L1	I	<b>Interrupt Request 14.</b>
IRQ15	K5	I	<b>Interrupt Request 15.</b>
DRQ7 / GPI21 (CF/CG), DRQ6 / GPI20, DRQ5 / GPI19, DRQ3 / GPI18, DRQ2 / FDCDRQ / SERIRQ / GPI12 / GPO24 / USB0C1#, DRQ1 / GPI17, DRQ0 / GPI16	N4, M5, M1, D3, H3, I / O / I E2, L3	I / I I / I I / I I / I I / I / I I / O / I I / I I / I	<b>DMA Request.</b> Used to request DMA services from the internal DMA controller.  DRQ2: Rx68[3] = 0 & Rx75[3] = 0 & Rx75[1] = 0 See also Function 0 Rx77[7]
DACK7# / USBIRQB / GPO21, DACK6# / USBIRQA / GPO20, DACK5# / MC97IRQ / GPO19 / SERIRQ, DACK3# / AC97IRQ / GPO18, DACK2# / USB0C0# / GPO25 / GPI13 / FDCIRQ, DACK1# / IDEIRQB / GPO17, DACK0# / IDEIRQA / GPO16	N2, M3, L4, D2, G5, E1, L2	O / O / O O / O / O O / O / O / I O / O / O O / I / O / I / I O / O / O O / O / O	<b>Acknowledge.</b> Used by the internal DMA controller to indicate that a request for DMA service has been granted. DACK5#: Rx68[3] = 0  DACK2#: Rx68[3] = 0 & Rx75[3] = 0 & Rx75[2] = 0 See also Function 0 Rx77[7]
TC	H1	O	<b>Terminal Count.</b> Terminal count indicator asserted to DMA slaves.
SPKR / strap	V5	O / I	<b>Speaker Drive.</b> Output of internal timer/counter 2. Also functions as a <b>strap input</b> sampled at reset to determine the function of the Audio / Game interface pins: 0=Disable Audio / Game interface (pins used for IDE Secondary Data Bus SDD[15-0]; ISA SA[15-0] pins used for ISA bus only), 1=Enable Audio / Game interface (pins used for Audio/Game functions; SDD[15-0] multiplexed with ISA SA[15-0] with SOE# / MASTER# as 245 OE# / DIR control.).
SOE# (default pin function) / GPO13 / MCCS# (CF/CG)	U5	O / O / O / O	<b>ISA Address (SA) Output Enable.</b> Asserted low when ISA address (SA) is valid (deasserted when SDD is valid) when SA and SDD are multiplexed on SA pins 15-0 (i.e., when SPKR is strapped low to enable the audio interface pins). SOE# is tied directly to the output enable of 74F245 transceivers that buffer IDE Secondary Bus data and ISA-address (see SA pins for more information).

XD Interface			
Signal Name	Pin #	I/O	Signal Description
XDIR / PCS0# / GPO12	T5	O	<b>X-Bus Data Direction.</b> (Rx76[1]=0) Asserted low for all I/O read cycles and for memory read cycles to the programmed BIOS address space. XDIR is tied directly to the direction control of a 74F245 transceiver that buffers the X-Bus data and ISA-Bus data. The transceiver output enable may be grounded. SD0-7 connect to the "A" side of the transceiver and XD0-7 connect to the "B" side. XDIR high indicates that SD0-7 drives XD0-7.

Serial IRQ			
Signal Name	Pin #	I/O	Signal Description
SERIRQ / DRQ2 / GPI12 / GPO24 / FDCDRQ / USB0C1#	H3	I	<b>Serial IRQ</b> (Rx68[3] = 1 and Rx74[6] = 0)
SERIRQ / DACK5# / GPO19 / MC97IRQ	L4	I	<b>Serial IRQ</b> (Rx68[3] = 1 and Rx74[6] = 1)

Internal Keyboard Controller			
Signal Name	Pin #	I/O	Signal Description
MSCK / IRQ1	D5	IO / I	<b>MultiFunction Pin</b> (Internal mouse controller enabled by Rx5A[1]) Rx5A[1]=1 <b>Mouse Clock</b> . From internal mouse controller. Rx5A[1]=0 <b>Interrupt Request 1</b> . Interrupt input 1.
MSDT / IRQ12	C5	IO / I	<b>MultiFunction Pin</b> (Internal mouse controller enabled by Rx5A[1]) Rx5A[1]=1 <b>Mouse Data</b> . From internal mouse controller. Rx5A[1]=0 <b>Interrupt Request 12</b> . Interrupt input 12.
KBCK / A20GATE	E5	IO / I	<b>MultiFunction Pin</b> (Internal keyboard controller enabled by Rx5A[0]) Rx5A[0]=1 <b>Keyboard Clock</b> . From internal keyboard controller Rx5A[0]=0 <b>Gate A20</b> . Input from external keyboard controller.
KBDT / KBRC	A5	IO / I	<b>MultiFunction Pin</b> (Internal keyboard controller enabled by Rx5A[0]) Rx5A[0]=1 <b>Keyboard Data</b> . From internal keyboard controller. Rx5A[0]=0 <b>Keyboard Reset</b> . From external keyboard controller (KBC) for CPURST# generation
KBCS# / ROMCS# / strap	C1	O / O / I	<b>Keyboard Chip Select</b> (Rx5A[0]=0). To external keyboard controller chip. <b>Power-Up Configuration Strap (Sampled At Reset):</b> 4.7K to GND = Socket-7, 4.7K to VCC3 = Socket-370 / Slot-1
KBIN[6-3] / SD[7-4]	W4, Y4, V3, W3	I / IO	<b>Keyboard Inputs 6-3</b> . Sampled at reset on SD[7-4] and latched into Rx5A[7-4].

Chip Selects			
Signal Name	Pin #	I/O	Signal Description
ROMCS# / KBCS# / strap	C1	O / O / I	<b>ROM Chip Select</b> (Rx5A[0]=1). Chip Select to the BIOS ROM. <b>Power-Up Configuration Strap (Sampled At Reset):</b> 4.7K to GND = Socket-7, 4.7K to VCC3 = Socket-370 / Slot-1
PCS0# / GPO12 / XDIR	T5	O / O / O	<b>Programmable Chip Select 0</b> (Rx76[1] = 1 and Rx76[4] = 1 (CD/CE) or Rx8B[0] = 1 (CF/CG)). Asserted during I/O cycles to programmable read or write ISA I/O port ranges. Addressed devices drive data to the SD pins (XDIR is disabled and the X-Bus is not implemented). See also Rx59[3] and Rx77[2].
MCCS# / GPIOD / GPIO11 (CD/CE)	U8	O / IO / IO	<b>Microcontroller Chip Select</b> (Rx74[5] = 1, Rx74[7] = 0, Rx76[3] = 1, Rx76[4] = 1). Asserted during read or write accesses to I/O ports 62h or 66h.
MCCS# / GPO13 / SOE# (CF/CG)	U5	O / IO / IO	<b>Microcontroller Chip Select</b> (Rx76[3] = 1, Rx76[4] = 0, Rx77[0] = 1). Asserted during read or write accesses to I/O ports 62h or 66h.

<b>General Purpose Inputs</b>			
<b>Signal Name</b>	<b>Pin #</b>	<b>I/O</b>	<b>Signal Description</b>
<b>GPI0</b> / IOCHCK#	F4	I	<b>General Purpose Input 0</b> (Rx74[0] = 0)
<b>GPI1</b> / IRQ8#	W11	I	<b>General Purpose Input 1</b> (Rx5A[2] = 1)
<b>GPI2</b> / BATLOW#	U11	I	<b>General Purpose Input 2</b>
<b>GPI3</b> / LID / WSC#	U10	I	<b>General Purpose Input 3</b>
<b>GPI4</b> / IRQ6 / SLPBTN#	G1	I	<b>General Purpose Input 4</b>
<b>GPI5</b> / THRM / PME#	T11	I	<b>General Purpose Input 5</b> (Read pin state at PMU IO Rx48[5])
<b>GPI6</b> / SMBALRT#	W10	I	<b>General Purpose Input 6</b>
<b>GPI7</b> / RING#	V11	I	<b>General Purpose Input 7</b>
<b>GPI8</b> / GPO8 / GPIOA / GPOWE#	T14	I	<b>General Purpose Input 8</b> (Rx74[2] = 0)
<b>GPI9</b> / GPO9 / GPIOB / FAN2 / DTEST	U12	I	<b>General Purpose Input 9</b> (Rx74[3] = 0)
<b>GPI10</b> / GPO10 / GPIOC / CHAS / ATEST	V14	I	<b>General Purpose Input 10</b> (Rx74[4] = 0)
<b>GPI11</b> / GPO11 / GPIOD	U8	I	<b>General Purpose Input 11</b> (Rx74[5] = 0)
<b>GPI12</b> / GPO24 / DRQ2 / FDCDRQ / USB0C1# / SERIRQ	H3	I	<b>General Purpose Input 12</b> (Rx75[3] = 1 & 75[1]=0 & 68[3]=0)
<b>GPI13</b> / GPO25 / DACK2# / FDCIRQ / USB0C0#	G5	I	<b>General Purpose Input 13</b> (Rx75[3] = 1 & 75[2]=0)
<b>GPI16</b> / DRQ0 (CF/CG)	L3	I	<b>General Purpose Input 16</b> (Rx77[7] = 1). Read at PMU IO 44[2]
<b>GPI17</b> / DRQ1 (CF/CG)	E2	I	<b>General Purpose Input 17</b> (Rx77[7] = 1). Read at PMU IO 44[3]
<b>GPI18</b> / DRQ3 (CF/CG)	D3	I	<b>General Purpose Input 18</b> (Rx77[7] = 1)
<b>GPI19</b> / DRQ5 (CF/CG)	M1	I	<b>General Purpose Input 19</b> (Rx77[7] = 1)
<b>GPI20</b> / DRQ6 (CF/CG)	M5	I	<b>General Purpose Input 20</b> (Rx77[7] = 1)
<b>GPI21</b> / DRQ7 (CF/CG)	N4	I	<b>General Purpose Input 21</b> (Rx77[7] = 1)
<b>GPI22</b> / SDD6 (CF/CG)	W15	I	<b>General Purpose Input 22</b> (Rx77[6] = 1, audio ena, game disa)
<b>GPI23</b> / SDD7 (CF/CG)	U14	I	<b>General Purpose Input 23</b> (Rx77[6] = 1, audio ena, game disa)
<b>GPI[23-22]</b> (SD[7-6] & RFSH# (CF) <b>GPI[23-16]</b> (SD[7-0] & RFSH#) (CG)	n/a	I	<b>General Purpose Inputs 16-23</b> (enabled on SD by RFSH# active) GPI if Rx77[6] = 0 (CF) or Rx77[7] = 0 (CG), SD if that bit = 1

See also Function 0 Rx77[7-6]

General Purpose Outputs			
Signal Name	Pin #	I/O	Signal Description
<u>GPO0 (H)</u> / SLOWCLK	T8	O	<b>General Purpose Output 0</b> (Function 4 Rx54[1-0] = 00). Output value determined by PMU I/O Rx4C[0]
<u>GPO1 (H)</u> / SUSAS# / APICACK#	V9	O	<b>General Purpose Output 1</b> (Rx74[7] = 0 and Function 4 Rx54[2] = 1)
<u>GPO2 (H)</u> / SUSB# / APICCS#	W9	O	<b>General Purpose Output 2</b> (Rx74[7] = 0 and Function 4 Rx54[3] = 1)
<u>GPO3</u> / SUSST1# (H)	V10	O	<b>General Purpose Output 3</b> (Function 4 Rx54[4] = 1)
<u>GPO4</u> / CPUTSP# (L)	Y12	O	<b>General Purpose Output 4</b> (Rx75[4] = 1)
<u>GPO5</u> / PCISTP# (L)	V12	O	<b>General Purpose Output 5</b> (Rx75[5] = 1)
<u>GPO7</u> / SLP# (OD)	T7	O	<b>General Purpose Output 7</b> (Rx75[7] = 1)
<u>GPO8</u> / GPI8 / GPIOA(OD)/GPOWE#	T14	O	<b>General Purpose Output 8</b> (Rx74[2] = 1 and Rx76[0] = 0)
<u>GPO9</u> / GPI9 / GPIOB(OD)/FAN2	U12	O	<b>General Purpose Output 9</b> (Rx74[3] = 1)
<u>GPO10</u> / GPI10 / GPIOC(OD)/CHAS	V14	O	<b>General Purpose Output 10</b> (Rx74[4] = 1 and Rx76[2] = 0)
<u>GPO11</u> / GPI11 / GPIOD(OD)	U8	O	<b>General Purpose Output 11</b> (CG: Rx74[5] = 1 and Rx76[3] = 0) (CF: Rx74[5] = 1, 74[7]=0, 76[4] = 0)
<u>GPO12</u> / XDIR (H) / PCS0#	T5	O	<b>General Purpose Output 12</b> (Rx76[1] = 1 and Rx76[4] = 0)
<u>GPO13</u> / SOE# (L) / MCCS#(CF/CG)	U5	O	<b>General Purpose Output 13</b> (Rx77[0] = 1) see also Rx76[4-3]
<u>GPO14</u> / IRTX (L)	E12	O	<b>General Purpose Output 14</b> (Rx76[5] = 1)
<u>GPO15</u> / IRRX (L)	D12	O	<b>General Purpose Output 15</b> (Rx76[5] = 1)
<u>GPO16</u> / DACK0# (CF/CG)	L2	O	<b>General Purpose Output 16</b> (Rx77[7] = 1 and Rx77[3] = 0)
<u>GPO17</u> / DACK1# (CF/CG)	E1	O	<b>General Purpose Output 17</b> (Rx77[7] = 1 and Rx77[3] = 0)
<u>GPO18</u> / DACK3# (CF/CG)	D2	O	<b>General Purpose Output 18</b> (Rx77[7] = 1 and Rx77[3] = 0)
<u>GPO19</u> / DACK5# (CF/CG)	L4	O	<b>General Purpose Output 19</b> (Rx77[7] = 1 and Rx77[3] = 0)
<u>GPO20</u> / DACK6# (CF/CG)	M3	O	<b>General Purpose Output 20</b> (Rx77[7] = 1 and Rx77[3] = 0)
<u>GPO21</u> / DACK7# (CF/CG)	N2	O	<b>General Purpose Output 21</b> (Rx77[7] = 1 and Rx77[3] = 0)
<u>GPO22</u> / SDD8 (CF/CG)	Y15	O	<b>General Purpose Output 22</b> (Rx77[6] = 1, audio enabled, game disabled)
<u>GPO23</u> / SDD9 (CF/CG)	V15	O	<b>General Purpose Output 23</b> (Rx77[6] = 1, audio enabled, game disabled)
<u>GPO24</u> / DRQ2 (H) / GPI12 / FDCDRQ / USB0C1# / SERIRQ	H3	O	<b>General Purpose Output 24</b> (Rx75[3] = 1 & Rx75[1]=1 & Rx68[3]=0)
<u>GPO25</u> / DACK2# (H) / GPI13 / FDCIRQ / USB0C0#	G5	O	<b>General Purpose Output 25</b> (Rx75[3] = 1 & Rx75[2]=1 & Rx68[3]=0)
<u>GPO[23-16]</u> (latched from SD[7-0])	n/a	O	<b>General Purpose Output 23-16</b> (Rx74[7]=0) latched by GPOWE# rising
<u>GPOWE#</u> / GPIOA / GPI8 / GPO8	T14	O	<b>General Purpose Output Write Enable</b> (Rx74[2] = 1 and Rx76[0] = 1).

Default pin functions are underlined in table above (with default level following in parentheses)

See also Function 0 Rx77[7-6]

General Purpose I/Os			
Signal Name	Pin #	I/O	Signal Description
<u>GPIOA</u> / GPI8 / GPO8 / GPOWE#	T14	IO	<b>General Purpose I/O A / 8</b> (Rx76[0] = 0). GPOWE# if Rx76[0] = 1. See also Rx74[2]
<u>GPIOB</u> / GPI9 / GPO9 / FAN2 / DTEST	U12	IO	<b>General Purpose I/O B / 9</b> . See also Rx74[3]
<u>GPIOC</u> / GPI10 / GPO10 / CHAS / ATEST	V14	IO	<b>General Purpose I/O C / 10</b> . (Rx76[2] = 0). See also Rx74[4]
<u>GPIOD</u> / GPI11 / GPO11 / MCCS# (CD/CE)	U8	IO	<b>General Purpose I/O D / 11</b> . (Rx76[3] = 0). See also Rx74[5]

<b>Hardware Monitoring</b>			
<b>Signal Name</b>	<b>Pin #</b>	<b>I/O</b>	<b>Signal Description</b>
<b>VSENS1</b>	U13	I	<b>Voltage Sense 2.0V.</b> Monitor for CPU core voltage.
<b>VSENS2</b>	V13	I	<b>Voltage Sense 2.5V.</b> Monitor for North Bridge core voltage.
<b>VSENS3</b>	W14	I	<b>Voltage Sense 5V.</b>
<b>VSENS4</b>	Y14	I	<b>Voltage Sense 12V.</b> Connect +12V through a resistive voltage divider to insure 5V max to the input pin (see MVP4 Design Guide for details).
<b>VREF</b>	T13	P	<b>Voltage Reference for Thermal Sensing</b> (5V ±5%)
<b>TSENS1</b>	W13	I	<b>Temperature Sense 1.</b>
<b>TSENS2</b>	Y13	I	<b>Temperature Sense 2.</b>
<b>FAN1</b>	T12	I	<b>Fan Speed Monitor 1.</b> (3.3V only)
<b>FAN2 / GPIOB/9 / DTEST</b>	U12	I	<b>Fan Speed Monitor 2.</b>
<b>CHAS / GPIOC/10 / ATEST</b>	V14	I	<b>Chassis Intrusion Detect</b> (Func 0 Rx76[2] = 1). Used for system security purposes.
<b>DTEST / FAN2 / GPIOB/9</b>	U12	O	<b>Hardware Monitor Digital Test Out</b>
<b>ATEST / CHAS / GPIOC/10</b>	V14	O	<b>Hardware Monitor Analog Test Out</b>

<b>Power Management</b>			
<b>Signal Name</b>	<b>Pin #</b>	<b>I/O</b>	<b>Signal Description</b>
<b>THRM / GPI5 / PME#</b>	T11	I	<b>Thermal Alarm Monitor</b> (Rx74[1] = 1)
<b>PWRBTN#</b>	Y11	I	<b>Power Button.</b> Used by the Power Management subsystem to monitor an external system on/off button or switch. The VT82C686A performs a 200us debounce of this input if Function 4 Rx40[5] is set to 1. (3.3V only)
<b>SLPBTN# / IRQ6 / GPI4</b>	G1	I / I / I	<b>Sleep Button.</b> Used by the Power Management subsystem to monitor an external system sleep button or switch. (Function 4 Rx40[6]=1) (10K PU to VCC if not used)
<b>RSMRST#</b>	V6	I	<b>Resume Reset.</b> Resets the internal logic connected to the VCCS power plane and also resets portions of the internal RTC logic.
<b>EXTSMI#</b>	Y10	IOD	<b>External System Management Interrupt.</b> When enabled to allow it, a falling edge on this input causes an SMI# to be generated to the CPU to enter SMI mode. (10K PU to VCCS if not used) (3.3V only)
<b>PME# / GPI5 / THRM</b>	T11	I	<b>Power Management Event.</b> (Rx74[1]=0) (1K PU to VCCS if not used)
<b>SMBALRT# / GPI6</b>	W10	I	<b>SMB Alert</b> (System Management Bus I/O space Rx08[3] = 1). When the chip is enabled to allow it, assertion generates an IRQ or SMI or power management event. (10K PU to VCCS if not used)
<b>LID / GPI3 / WSC# (CG)</b>	U10	I	<b>Notebook Computer Display Lid Open / Closed Monitor.</b> Used by the Power Management subsystem to monitor the opening and closing of the display lid of notebook computers. Can be used to detect either low-to-high and/or high-to-low transitions to generate an SMI#. The VT82C686A performs a 200 usec debounce of this input if Function 4 Rx40[5] is set to 1. (10K PU to VCCS if not used)
<b>RING# / GPI7</b>	V11	I	<b>Ring Indicator.</b> May be connected to external modem circuitry to allow the system to be re-activated by a received phone call. (10K PU to VCCS if not used)
<b>BATLOW# / GPI2</b>	U11	I	<b>Battery Low Indicator.</b> (10K PU to VCCS if not used) (3.3V only)
<b>CPUSTP# / GPO4</b>	Y12	O	<b>CPU Clock Stop</b> (Rx75[4] = 0). Signals the system clock generator to disable the CPU clock outputs. Not connected if not used. See also PMU I/O Rx2C[3].
<b>PCISTP# / GPO5</b>	V12	O	<b>PCI Clock Stop</b> (Rx75[5] = 0). Signals the system clock generator to disable the PCI clock outputs. Not connected if not used.
<b>SUSA# / GPO1 / APICD0 (CG)</b>	V9	O	<b>Suspend Plane A Control</b> (Rx74[7]=0 and Function 4 Rx54[2]=0). Asserted during power management POS, STR, and STD suspend states. Used to control the primary power plane. (10K PU to VCCS if not used)
<b>SUSB# / GPO2</b>	W9	O	<b>Suspend Plane B Control</b> (Rx74[7]=0 and Function 4 Rx54[3]=0). Asserted during power management STR and STD suspend states. Used to control the secondary power plane. (10K PU to VCCS if not used)
<b>SUSC#</b>	Y9	O	<b>Suspend Plane C Control.</b> Asserted during power management STD suspend state. Used to control the tertiary power plane. Also connected to ATX power-on circuitry.
<b>SUSST1# / GPO3</b>	V10	O	<b>Suspend Status 1</b> (Func4 Rx54[4] = 1 for GPO3). Typically connected to the North Bridge to provide information on host clock status. Asserted when the system may stop the host clock, such as Stop Clock or during POS, STR, or STD suspend states. Connect 10K PU to VCCS.
<b>SUSCLK / APICD1 (CG)</b>	T10	O	<b>Suspend Clock.</b> 32.768 KHz output clock for use by the North Bridge (e.g., Apollo MVP3 or MVP4) for DRAM refresh purposes. Stopped during Suspend-to-Disk and Soft-Off modes. Connect 10K PU to VCCS.



Resets and Clocks			
Signal Name	Pin #	I/O	Signal Description
PWRGD	W6	I	<b>Power Good.</b> Connected to the PWRGOOD signal on the Power Supply.
PCIRST#	B16	O	<b>PCI Reset.</b> Active low reset signal for the PCI bus. The VT82C686A will assert this pin during power-up or from the control register.
RSTDRV	J1	O	<b>Reset Drive.</b> Reset signal to the ISA bus. Connect through an inverter to the chipset north bridge RESET# input and to PCI bus RESET#.
BCLK	H5	O	<b>Bus Clock.</b> ISA bus clock.
OSC	E4	I	<b>Oscillator.</b> 14.31818 MHz clock signal used by the internal Timer.
RTCX1	Y5	I	<b>RTC Crystal Input:</b> 32.768 KHz crystal or oscillator input. This input is used for the internal RTC and for power-well power management logic.
RTCX2	W5	O	<b>RTC Crystal Output:</b> 32.768 KHz crystal output
SLOWCLK / GPO0	T8	O	<b>Slow Clock.</b> Frequency selectable if PMU function 4 Rx54[1-0] is nonzero (set to 01, 10, or 11).

Power and Ground			
Signal Name	Pin #	I/O	Signal Description
VCC	F7, F10, F12-F14, H6, H15, J6, J15, K6, K15, M6, M15, N6, N15, R7-R8, R11, R14	P	<b>Core Power.</b> 3.3V nominal (3.15V to 3.45V). This supply is turned on only when the mechanical switch on the power supply is turned on and the PWRON signal is conditioned high. This pin should be connected to the same voltage as the CPU I/O circuitry. Internally connected to hardware monitoring system voltage detection circuitry for 3.3V monitoring.
GND	F6, F11, F15, G6, G15, J9-J12, K9-K12, L6, L9-L12, L15, M9-M12, P6, P15, R6, R15	P	<b>Ground.</b> Connect to primary motherboard ground plane.
VCCS	R9-R10	P	<b>Suspend Power.</b> Always available unless the mechanical switch of the power supply is turned off. If the “soft-off” state is not implemented, then this pin can be connected to VCC. Signals powered by or referenced to this plane are: PWRGD, RSMRST#, PWRBTN#, SMBCLK, SMBDATA, SUSCLK, SUSA# / GPO1, SUSB# / GPO2, SUSC#, SUSST1# / GPO6, GPI1 / IRQ8#, GPI2 / BATLOW#, GPI3 / LID, GPI5 / PME#, GPI6 / SMBALRT#, GPI7 / RING#, GPO0
VBAT	Y6	P	<b>RTC Battery.</b> Battery input for internal RTC (RTCX1, RTCX2)
VREF	T13	P	<b>Voltage Reference</b> (5V ±5%). For thermal sensing and 5V input tolerance.
VCCH	R12	P	<b>Hardware Monitor Power.</b> Power for hardware monitoring subsystem (voltage monitoring, temperature monitoring, and fan speed monitoring). Connect to VCC through a ferrite bead.
GNDH	R13	P	<b>Hardware Monitor Ground.</b> Connect to GND through a ferrite bead.
VCCU	F9	P	<b>USB Differential Output Power.</b> Power for USB differential outputs (USBP0+, P0-, P1+, P1-, P2+, P2-, P3+, P3-). Connect to VCC through a ferrite bead.
GNDU	F8	P	<b>USB Differential Output Ground.</b> Connect to GND through a ferrite bead.



# REGISTERS

## Register Overview

The following tables summarize the configuration and I/O registers of the VT82C686A. These tables also document the power-on default value (“Default”) and access type (“Acc”) for each register. Access type definitions used are RW (Read/Write), RO (Read/Only), “—” for reserved / used (essentially the same as RO), and RWC (or just WC) (Read / Write 1’s to Clear individual bits). Registers indicated as RW may have some read/only bits that always read back a fixed value (usually 0 if unused); registers designated as RWC or WC may have some read-only or read write bits (see individual register descriptions for details).

Detailed register descriptions are provided in the following section of this document. All offset and default values are shown in hexadecimal unless otherwise indicated

**Table 2. System I/O Map**

<u>Port</u>	<u>Function</u>	<u>Actual Port Decoding</u>
00-1F	Master DMA Controller	0000 0000 000x nnnn
20-3F	Master Interrupt Controller	0000 0000 001x xxxn
40-5F	Timer / Counter	0000 0000 010x xxnn
60-6F	Keyboard Controller	0000 0000 0110 xnxn
(60h)	KBC Data	0000 0000 0110 x0x0
(61h)	Misc Functions & Spkr Ctrl	0000 0000 0110 xxx1
(64h)	KBC Command / Status	0000 0000 0110 x1x0
70-77	RTC/CMOS/NMI-Disable	0000 0000 0111 0nnn
78-7F	-available for system use-	0000 0000 0111 1xxx
80	-reserved- (debug port)	0000 0000 1000 0000
81-8F	DMA Page Registers	0000 0000 1000 nnnn
90-91	-available for system use-	0000 0000 1001 000x
92	System Control	0000 0000 1001 0010
93-9F	-available for system use-	0000 0000 1001 nnnn
A0-BF	Slave Interrupt Controller	0000 0000 101x xxxn
C0-DF	Slave DMA Controller	0000 0000 110n nnnx
E0-FF	-available for system use-	0000 0000 111x xxxx
100-CF7	-available for system use*	
CF8-CFB	PCI Configuration Address	0000 1100 1111 10xx
CFC-CFF	PCI Configuration Data	0000 1100 1111 11xx
D00-FFFF	-available for system use-	

\* On-Chip Super-I/O Functions – PC-Standard Port Addresses

200-20F	Game Port
2E8-2EF	COM4
2F8-2FF	COM2
378-37F	Parallel Port (Standard & EPP)
3E8-3EF	COM3
3F0-3F1	Configuration Index / Data
3F0-3F7	Floppy Controller
3F8-3FF	COM1
778-77A	Parallel Port (ECP Extensions) (Port 378+400)

**Table 3. Registers**

**Legacy I/O Registers**

<b>Port</b>	<b>Master DMA Controller Registers</b>	<b>Default</b>	<b>Acc</b>
00	Channel 0 Base & Current Address		RW
01	Channel 0 Base & Current Count		RW
02	Channel 1 Base & Current Address		RW
03	Channel 1 Base & Current Count		RW
04	Channel 2 Base & Current Address		RW
05	Channel 2 Base & Current Count		RW
06	Channel 3 Base & Current Address		RW
07	Channel 3 Base & Current Count		RW
08	Status / Command		RW
09	Write Request		WO
0A	Write Single Mask		WO
0B	Write Mode		WO
0C	Clear Byte Pointer FF		WO
0D	Master Clear		WO
0E	Clear Mask		WO
0F	Read / Write Mask		RW

<b>Port</b>	<b>Master Interrupt Controller Regs</b>	<b>Default</b>	<b>Acc</b>
20	Master Interrupt Control	—	*
21	Master Interrupt Mask	—	*
20	Master Interrupt Control Shadow	—	RW
21	Master Interrupt Mask Shadow	—	RW

\* RW if shadow registers are disabled

<b>Port</b>	<b>Timer/Counter Registers</b>	<b>Default</b>	<b>Acc</b>
40	Timer / Counter 0 Count		RW
41	Timer / Counter 1 Count		RW
42	Timer / Counter 2 Count		RW
43	Timer / Counter Control		WO

<b>Port</b>	<b>Keyboard Controller Registers</b>	<b>Default</b>	<b>Acc</b>
60	Keyboard Controller Data		RW
61	Misc Functions & Speaker Control		RW
64	Keyboard Ctrlr Command / Status		RW

<b>Port</b>	<b>CMOS / RTC / NMI Registers</b>	<b>Default</b>	<b>Acc</b>
70	CMOS Memory Address & NMI Disa		WO
71	CMOS Memory Data (128 bytes)		RW
72	CMOS Memory Address		RW
73	CMOS Memory Data (256 bytes)		RW
74	CMOS Memory Address		RW
75	CMOS Memory Data (256 bytes)		RW

NMI Disable is port 70h (CMOS Memory Address) bit-7.  
 RTC control occurs via specific CMOS data locations (0-Dh).  
 Ports 72-73 may be used to access all 256 locations of CMOS.  
 Ports 74-75 may be used to access CMOS if the internal RTC is disabled.

**Legacy I/O Registers (continued)**

<b>Port</b>	<b>DMA Page Registers</b>	<b>Default</b>	<b>Acc</b>
87	DMA Page – DMA Channel 0		RW
83	DMA Page – DMA Channel 1		RW
81	DMA Page – DMA Channel 2		RW
82	DMA Page – DMA Channel 3		RW
8F	DMA Page – DMA Channel 4		RW
8B	DMA Page – DMA Channel 5		RW
89	DMA Page – DMA Channel 6		RW
8A	DMA Page – DMA Channel 7		RW

<b>Port</b>	<b>System Control Registers</b>	<b>Default</b>	<b>Acc</b>
92	System Control		RW

<b>Port</b>	<b>Slave Interrupt Controller Regs</b>	<b>Default</b>	<b>Acc</b>
A0	Slave Interrupt Control	—	*
A1	Slave Interrupt Mask	—	*
A0	Slave Interrupt Control Shadow	—	RW
A1	Slave Interrupt Mask Shadow	—	RW

\* RW accessible if shadow registers are disabled

<b>Port</b>	<b>Slave DMA Controller Registers</b>	<b>Default</b>	<b>Acc</b>
C0	Channel 0 Base & Current Address		RW
C2	Channel 0 Base & Current Count		RW
C4	Channel 1 Base & Current Address		RW
C6	Channel 1 Base & Current Count		RW
C8	Channel 2 Base & Current Address		RW
CA	Channel 2 Base & Current Count		RW
CC	Channel 3 Base & Current Address		RW
CE	Channel 3 Base & Current Count		RW
D0	Status / Command		RW
D2	Write Request		WO
D4	Write Single Mask		WO
D6	Write Mode		WO
D8	Clear Byte Pointer FF		WO
DA	Master Clear		WO
DC	Clear Mask		WO
DE	Read / Write Mask		RW

**Super-I/O Configuration Registers (I/O Space)**

Port	Super-I/O Configuration Registers	Default	Acc
3F0	Super-I/O Config Index (Rx85[1]=1)	00	RW
3F1	Super-I/O Config Data (Rx85[1]=1)	00	RW

**Super-I/O Configuration Registers (Indexed via Port 3F0/1)**

Offset	Super-I/O Control	Default	Acc
00-DF	-reserved-	00	RO
E0	Super-I/O Device ID	3C	RW
E1	Super-I/O Device Revision	00	RW
E2	Function Select	03	RW
E3	Floppy Ctrlr Base Addr (def = 3F0-7)	FC	RW
E4-E5	-reserved-	00	RO
E6	Parallel Port Base Addr (def = 378-F)	DE	RW
E7	Serial Port 1 Base Addr (def = 3F8-F)	FE	RW
E8	Serial Port 2 Base Addr (def = 2F8-F)	BE	RW
E9-ED	-reserved-	00	RO
EE	Serial Port Configuration	00	RW
EF	Power Down Control	00	RW
F0	Parallel Port Control	00	RW
F1	Serial Port Control	00	RW
F2	Test Mode (Do Not Program)	00	RW
F3	-reserved-	00	RO
F4	Test Mode (Do Not Program) 2	00	RW
F5	-reserved-	00	RO
F6	Floppy Controller Configuration	00	RW
F7	-reserved-	00	RO
F8	Floppy Controller Drive Select	00	RW
F9-FB	-reserved-	00	RO
FC	General Purpose I/O	00	RW
FD-FF	-reserved-	00	RO

**Super-I/O I/O Ports**

Offset	Floppy Disk Controller (Base = E3)	Default	Acc
00-01	-reserved-	00	--
02	FDC Command	--	RW
03	-reserved-	00	--
04	FDC Main Status	--	RO
04	FDC Data Rate Select	02	WO
05	FDC Data	--	RW
06	-reserved-	00	--
07	Disk Change Status	--	RO

Offset	Parallel Port (Base = E6)	Default	Acc
00	Parallel Port Data	--	RW
01	Parallel Port Status	--	RO
02	Parallel Port Control	E0	RW
03	EPP Address		RW
04	EPP Data Port 0		RW
05	EPP Data Port 1		RW
06	EPP Data Port 2		RW
07	EPP Data Port 3		RW
400h	ECP Data / Configuration A		RW
401h	ECP Configuration B		RW
402h	ECP Extended Control		RW

Offset	Serial Port 1 (Base = E7)	Default	Acc
0	Transmit (Wr) / Receive (Rd) Buffer		RW
1	Interrupt Enable		RW
2	FIFO Control		WO
2	Interrupt Status		RO
3	UART Control		RW
4	Handshake Control		RW
5	UART Status		RW
6	Handshake Status		RW
7	Scratchpad		RW
9-8	Baud Rate Generator Divisor		RW
A-F	-undefined-		--

Offset	Serial Port 2 (Base = E8)	Default	Acc
0	Transmit (Wr) / Receive (Rd) Buffer		RW
1	Interrupt Enable		RW
2	FIFO Control		WO
2	Interrupt Status		RO
3	UART Control		RW
4	Handshake Control		RW
5	UART Status		RW
6	Handshake Status		RW
7	Scratchpad		RW
9-8	Baud Rate Generator Divisor		RW
A-F	-undefined-		--

**PCI Function 0 Registers – PCI-to-ISA Bridge**

**Configuration Space PCI-to-ISA Bridge Header Registers**

Offset	PCI Configuration Space Header	Default	Acc
1-0	Vendor ID	<b>1106</b>	RO
3-2	Device ID	<b>0686</b>	RO
5-4	Command	<b>0087</b>	RW
7-6	Status	<b>0200</b>	WC
8	Revision ID	<b>nn</b>	RO
9	Programming Interface	00	RO
A	Sub Class Code	<b>01</b>	RO
B	Base Class Code	<b>06</b>	RO
C	-reserved- (cache line size)	00	—
D	-reserved- (latency timer)	00	—
E	Header Type	<b>80</b>	RO
F	Built In Self Test (BIST)	00	RO
10-27	-reserved- (base address registers)	00	—
28-2B	-reserved- (unassigned)	00	—
2F-2C	Subsystem ID Read	00	RO
30-33	-reserved- (expansion ROM base addr)	00	—
34-3B	-reserved- (unassigned)	00	—
3C	-reserved- (interrupt line)	00	—
3D	-reserved- (interrupt pin)	00	—
3E	-reserved- (min gnt)	00	—
3F	-reserved- (max lat)	00	—

**Configuration Space PCI-to-ISA Bridge-Specific Registers**

Offset	ISA Bus Control	Default	Acc
40	ISA Bus Control	00	RW
41	ISA Test Mode	00	RW
42	ISA Clock Control	00	RW
43	ROM Decode Control	00	RW
44	Keyboard Controller Control	00	RW
45	Type F DMA Control	00	RW
46	Miscellaneous Control 1	00	RW
47	Miscellaneous Control 2	00	RW
48	Miscellaneous Control 3	<b>01</b>	RW
49	-reserved-	00	—
4A	IDE Interrupt Routing	<b>04</b>	RW
4B	-reserved-	00	—
4C	DMA / Master Mem Access Control 1	00	RW
4D	DMA / Master Mem Access Control 2	00	RW
4F-4E	DMA / Master Mem Access Control 3	<b>0300</b>	RW

Offset	Plug and Play Control	Default	Acc
50	PnP DMA Request Control	<b>2D</b>	RW
51	PnP Routing for LPT / FDC IRQ	00	RW
52	PnP Routing for COM2 / COM1 IRQ	00	RW
53	-reserved-	00	—
54	PCI IRQ Edge / Level Select	00	RW
55	PnP Routing for PCI INTA	00	RW
56	PnP Routing for PCI INTB-C	00	RW
57	PnP Routing for PCI INTD	00	RW
58	APIC IRQ Output Control	00	RW
59	-reserved-	<b>04</b>	—
5A	KBC / RTC Control	<b>x4†</b>	RW
5B	Internal RTC Test Mode	00	RW
5C	DMA Control	00	RW
5D-5E	-reserved-	00	—
5F	-reserved- (do not program)	<b>04</b>	RW

† Bit 7-4 power-up default depends on external strapping

Offset	Distributed DMA	Default	Acc
61-60	Channel 0 Base Address / Enable	0000	RW
63-62	Channel 1 Base Address / Enable	0000	RW
65-64	Channel 2 Base Address / Enable	0000	RW
67-66	Channel 3 Base Address / Enable	0000	RW
69-68	Serial IRQ Control	0000	RW
6B-6A	Channel 5 Base Address / Enable	0000	RW
6D-6C	Channel 6 Base Address / Enable	0000	RW
6F-6E	Channel 7 Base Address / Enable	0000	RW

Offset	Miscellaneous	Default	Acc
70	Subsystem ID Write	00	WO
71-73	-reserved-	00	—
74	GPIO Control 1	00	RW
75	GPIO Control 2	00	RW
76	GPIO Control 3	00	RW
77	GPIO Control 4	<b>10</b>	RW
79-78	PCS0# I/O Port Address	0000 0000	RW
7B-7A	PCS1# I/O Port Address	0000 0000	RW
7D-7C	PCI DMA Channel Enable	0000	RW
7F-7E	32-Bit DMA Control	0000	RW
80	Programmable Chip Select Mask	00	RW
81	ISA Positive Decoding Control 1	00	RW
82	ISA Positive Decoding Control 2	00	RW
83	ISA Positive Decoding Control 3	00	RW
84	ISA Positive Decoding Control 4	00	RW
85	Extended Function Enable	00	RW
86-87	PnP IRQ/DRQ Test (do not program)	00	RW
88	PLL Test	00	RW
89	PLL Control	00	RW
8A	PCS2/3 I/O Port Address Mask	00	RW
8B	PCS Control	00	RW
8D-8C	PCS2# I/O Port Address	0000	RW
8F-8E	PCS3# I/O Port Address	0000	RW
90-FF	-reserved-	00	—

**PCI Function 1 Registers – IDE Controller**

**Configuration Space IDE Header Registers**

Offset	PCI Configuration Space Header	Default	Acc
1-0	Vendor ID	<b>1106</b>	RO
3-2	Device ID	<b>0571</b>	RO
5-4	Command	<b>0080</b>	RO
7-6	Status	<b>0280</b>	<b>RW</b>
8	Revision ID	<b>nn</b>	RO
9	Programming Interface	<b>85</b>	<b>RW</b>
A	Sub Class Code	<b>01</b>	RO
B	Base Class Code	<b>01</b>	RO
C	-reserved- (cache line size)	00	—
D	Latency Timer	00	<b>RW</b>
E	Header Type	00	RO
F	Built In Self Test (BIST)	00	RO
13-10	Base Address – Pri Data / Command	<b>000001F0</b>	RO
17-14	Base Address – Pri Control / Status	<b>000003F4</b>	RO
1B-18	Base Address – Sec Data / Command	<b>00000170</b>	RO
1F-1C	Base Address – Sec Control / Status	<b>00000374</b>	RO
23-20	Base Address – Bus Master Control	<b>0000CC01</b>	<b>RW</b>
24-2F	-reserved- (unassigned)	00	—
30-33	-reserved- (expan ROM base addr)	00	—
34	Capability Pointer	<b>C0</b>	RO
35-3B	-reserved- (unassigned)	00	—
3C	Interrupt Line	<b>0E</b>	<b>RW</b>
3D	Interrupt Pin	00	RO
3E	Minimum Grant	00	RO
3F	Maximum Latency	00	RO

**Configuration Space IDE-Specific Registers**

Offset	Configuration Space IDE Registers	Default	Acc
40	IDE Chip Enable	<b>00</b>	RW
41	IDE Configuration	<b>06</b>	RW
42	-reserved- (do not program)	<b>09</b>	<b>RW</b>
43	IDE FIFO Configuration	<b>0A</b>	RW
44	IDE Miscellaneous Control 1	<b>68</b>	RW
45	IDE Miscellaneous Control 2	00	RW
46	IDE Miscellaneous Control 3	<b>C0</b>	RW
4B-48	IDE Drive Timing Control	<b>A8A8A8A8</b>	RW
4C	IDE Address Setup Time	<b>FF</b>	RW
4D	-reserved- (do not program)	00	<b>RW</b>
4E	Sec Non-1F0 IDE Port Access Timing	<b>FF</b>	RW
4F	Pri Non-1F0 IDE Port Access Timing	<b>FF</b>	RW

**Configuration Space IDE-Specific Registers (continued)**

Offset	Configuration Space IDE Registers	Default	Acc
53-50	UltraDMA Extd Timing Ctrl CD/CE:	<b>03030303</b>	RW
	CF/CG:	<b>07070707</b>	
54	UltraDMA FIFO Control	<b>06</b>	RW
55-5F	-reserved-	00	—
61-60	IDE Primary Sector Size	<b>0200</b>	RW
62-67	-reserved-	00	—
69-68	IDE Secondary Sector Size	<b>0200</b>	RW
69-6F	-reserved-	00	—
70	IDE Primary Status	00	RW
71	IDE Primary Intrpt Control (CF/CG)	00	RW
72-73	-reserved-	00	—
74	IDE Primary Command 1 (CD/CE)	00	RW
75	IDE Primary Command 2 (CD/CE)	00	RW
76-77	-reserved-	00	—
78	IDE Secondary Status	00	RW
79	IDE Secondary Intrpt Ctrl (CF/CG)	00	RW
7A-7B	-reserved-	00	—
7C	IDE Secondary Command 1 (CD/CE)	00	RW
7D	IDE Secondary Command 2 (CD/CE)	00	RW
7E-7F	-reserved-	00	—
83-80	IDE Primary S/G Descriptor Address	0000 0000	RW
84-87	-reserved-	00	—
8B-88	IDE Secondary S/G Descriptor Addr	0000 0000	RW
8C-BF	-reserved-	00	—
C3-C0	PCI PM Block 1 (CF/CG)	<b>0201</b>	<b>RO</b>
C7-C4	PCI PM Block 2 (CF/CG)	0000	RW
C8-FF	-reserved-	00	—

**I/O Registers – IDE Controller (SFF 8038 v1.0 Compliant)**

Offset	IDE I/O Registers	Default	Acc
0	Primary Channel Command	00	RW
1	-reserved-	00	—
2	Primary Channel Status	00	<b>WC</b>
3	-reserved-	00	—
4-7	Primary Channel PRD Table Addr	00	RW
8	Secondary Channel Command	00	RW
9	-reserved-	00	—
A	Secondary Channel Status	00	<b>WC</b>
B	-reserved-	00	—
C-F	Secondary Channel PRD Table Addr	00	RW

**PCI Function 2 Registers – USB Controller Ports 0-1**

**PCI Function 3 Registers – USB Controller Ports 2-3**

**Configuration Space USB Header Registers**

Offset	PCI Configuration Space Header	Default	Acc
1-0	Vendor ID	<b>1106</b>	RO
3-2	Device ID	<b>3038</b>	RO
5-4	Command	0000	<b>RW</b>
7-6	Status	<b>0200</b>	<b>WC</b>
8	Revision ID	<b>nn</b>	RO
9	Programming Interface	00	RO
A	Sub Class Code	<b>03</b>	RO
B	Base Class Code	<b>0C</b>	RO
C	Cache Line Size	00	RO
D	Latency Timer	<b>16</b>	<b>RW</b>
E	Header Type	00	RO
F	BIST	00	RO
10-1F	-reserved-	00	—
23-20	USB I/O Register Base Address	<b>00000301</b>	<b>RW</b>
24-3B	-reserved-	00	—
3C	Interrupt Line	00	<b>RW</b>
3D	Interrupt Pin	<b>04</b>	<b>RO</b>
3E-3F	-reserved-	00	—

**Configuration Space USB Header Registers**

Offset	PCI Configuration Space Header	Default	Acc
1-0	Vendor ID	<b>1106</b>	RO
3-2	Device ID	<b>3038</b>	RO
5-4	Command	0000	<b>RW</b>
7-6	Status	<b>0200</b>	<b>WC</b>
8	Revision ID	<b>nn</b>	RO
9	Programming Interface	00	RO
A	Sub Class Code	<b>03</b>	RO
B	Base Class Code	<b>0C</b>	RO
C	Cache Line Size	00	RO
D	Latency Timer	<b>16</b>	<b>RW</b>
E	Header Type	00	RO
F	BIST	00	RO
10-1F	-reserved-	00	—
23-20	USB I/O Register Base Address	<b>00000301</b>	<b>RW</b>
24-3B	-reserved-	00	—
3C	Interrupt Line	00	<b>RW</b>
3D	Interrupt Pin	<b>04</b>	<b>RO</b>
3E-3F	-reserved-	00	—

**Configuration Space USB-Specific Registers**

Offset	USB Control	Default	Acc
40	USB Miscellaneous Control 1	00	<b>RW</b>
41	USB Miscellaneous Control 2	<b>10</b>	<b>RW</b>
42	USB FIFO Control I (CF/CG)	00	<b>RW</b>
43	USB FIFO Control II (CG)	00	<b>RW</b>
44-45	-reserved- (test, do not program)		<b>RW</b>
46-47	-reserved- (test)		RO
48-5F	-reserved-	00	—
60	USB Serial Bus Release Number	<b>10</b>	RO
61-7F	-reserved-	00	—
83-80	PM Capability (CF/CG)	<b>0002 0001</b>	RO
84	PM Capability Status (CF/CG)	00	<b>RW</b>
85-BF	-reserved-	00	—
C1-C0	USB Legacy Support	<b>2000</b>	<b>RW</b>
C2-FF	-reserved-	00	—

**Configuration Space USB-Specific Registers**

Offset	USB Control	Default	Acc
40	USB Miscellaneous Control 1	00	<b>RW</b>
41	USB Miscellaneous Control 2	<b>10</b>	<b>RW</b>
42	USB FIFO Control I (CF/CG)	00	<b>RW</b>
43	USB FIFO Control II (CG)	00	<b>RW</b>
44-45	-reserved- (test only, do not program)		<b>RW</b>
46-47	-reserved- (test)		RO
48-5F	-reserved-	00	—
60	USB Serial Bus Release Number	<b>10</b>	RO
61-7F	-reserved-	00	—
83-80	PM Capability (CF/CG)	<b>0002 0001</b>	RO
84	PM Capability Status (CF/CG)	00	<b>RW</b>
85-BF	-reserved-	00	—
C1-C0	USB Legacy Support	<b>2000</b>	<b>RW</b>
C2-FF	-reserved-	00	—

**I/O Registers – USB Controller**

Offset	USB I/O Registers	Default	Acc
1-0	USB Command	0000	RW
3-2	USB Status	0000	<b>WC</b>
5-4	USB Interrupt Enable	0000	RW
7-6	Frame Number	0000	RW
B-8	Frame List Base Address	00000000	RW
C	Start Of Frame Modify	<b>40</b>	RW
11-10	Port 0 Status / Control	<b>0080</b>	<b>WC</b>
13-12	Port 1 Status / Control	<b>0080</b>	<b>WC</b>
14-1F	-reserved-	00	—

**I/O Registers - USB Controller**

Offset	USB I/O Registers	Default	Acc
1-0	USB Command	0000	RW
3-2	USB Status	0000	<b>WC</b>
5-4	USB Interrupt Enable	0000	RW
7-6	Frame Number	0000	RW
B-8	Frame List Base Address	00000000	RW
C	Start Of Frame Modify	<b>40</b>	RW
11-10	Port 2 Status / Control	<b>0080</b>	<b>WC</b>
13-12	Port 3 Status / Control	<b>0080</b>	<b>WC</b>
14-1F	-reserved-	00	—



**PCI Function 4 Registers - Power Management**

**Configuration Space Power Management Header Registers**

Offset	PCI Configuration Space Header	Default	Acc
1-0	Vendor ID	<b>1106</b>	RO
3-2	Device ID	<b>3068</b>	RO
5-4	Command	0000	RO
7-6	Status	<b>0280</b>	<b>WC</b>
8	Revision ID	<b>nn</b>	RO
9	Programming Interface	00†	RO
A	Sub Class Code	00†	RO
B	Base Class Code	00†	RO
C	Cache Line Size	00	RO
D	Latency Timer	00	RO
E	Header Type	00	RO
F	BIST	00	RO
10-3F	-reserved-	00	—

† The default values for these registers may be changed by writing to offsets 61-63h (see below).

**Configuration Space Power Management Registers**

Offset	Power Management	Default	Acc
40	General Configuration 0	00	RW
41	General Configuration 1	00	RW
42	ACPI Interrupt Select	00	RW
43	Internal Timer Read Test	—	<b>RO</b>
45-44	Primary Interrupt Channel	0000	RW
47-46	Secondary Interrupt Channel	0000	RW
4B-48	Power Mgmt I/O Base (256 Bytes)	<b>0000 0001</b>	RW
4C	Host Bus Power Management Control	00	RW
4D	Throttle / Clock Stop Control	00	RW
4E-4F	-reserved-	00	—
53-50	GP Timer Control	0000 0000	RW
54	Power Well Control	00	RW
55	USB Wakeup Control	00	RW
56-57	-reserved-	00	—
58	GP2 / GP3 Timer Control	00	RW
59	GP2 Timer	00	RW
5A	GP3 Timer	00	RW
5B-60	-reserved-	00	—
61	Write value for Offset 9 (Prog Intfc)	00	<b>WO</b>
62	Write value for Offset A (Sub Class)	00	<b>WO</b>
63	Write value for Offset B (Base Class)	00	<b>WO</b>
64-7F	-reserved-	00	—

**Configuration Space Hardware Monitor Registers**

Offset	System Management Bus	Default	Acc
71-70	Hardware Mon IO Base (128 Bytes)	<b>0001</b>	RW
72-73	-reserved-	00	—
74	Hardware Monitor Control	00	RW
75-8F	-reserved-	00	—

**Configuration Space SMBus Registers**

Offset	System Management Bus	Default	Acc
93-90	SMBus I/O Base (16 Bytes)	<b>0000 0001</b>	RW
94-D1	-reserved-	00	—
D2	SMBus Host Configuration	00	RW
D3	SMBus Host Slave Command	00	RW
D4	SMBus Slave Address Shadow Port 1	00	RW
D5	SMBus Slave Address Shadow Port 2	00	RW
D6	SMBus Revision ID	<b>nn</b>	<b>RO</b>
D7-FF	-reserved-	00	—

**I/O Space Power Management- Registers**

Offset	Basic Control / Status Registers	Default	Acc
1-0	Power Management Status	0000	<b>WC</b>
3-2	Power Management Enable	0000	RW
5-4	Power Management Control	0000	RW
6-7	-reserved-	00	—
B-8	Power Management Timer	0000 0000	RW
C-F	-reserved-	00	—

Offset	Processor Registers	Default	Acc
13-10	Processor and PCI Bus Control	0000 0000	RW
14	Processor LVL2	00	<b>RO</b>
15	Processor LVL3	00	<b>RO</b>
16-1F	-reserved-	00	—

Offset	General Purpose Registers	Default	Acc
21-20	General Purpose Status	0000	<b>WC</b>
23-22	General Purpose SCI Enable	0000	RW
25-24	General Purpose SMI Enable	0000	RW
26-27	-reserved-	00	—

Offset	Generic Registers	Default	Acc
29-28	Global Status	0000	<b>WC</b>
2B-2A	Global Enable	0000	RW
2D-2C	Global Control	<b>0010</b>	RW
2E	-reserved-	00	—
2F	SMI Command	00	RW
33-30	Primary Activity Detect Status	0000 0000	<b>WC</b>
37-34	Primary Activity Detect Enable	0000 0000	RW
3B-38	GP Timer Reload Enable	0000 0000	RW
3C-3F	-reserved-	00	—

Offset	General Purpose I/O Registers	Default	Acc
40	Extended I/O Trap Status (CF/CG)	00	<b>WC</b>
41	-reserved-	00	—
42	Extended I/O Trap Enable (CF/CG)	00	RW
43	-reserved-	00	—
44	External SMI / GPI Input Value	<b>input</b>	<b>RO</b>
45	SMI / IRQ / Resume Status	00	<b>RO</b>
46-47	-reserved-	00	—
4B-48	GPI Port Input Value	<b>input</b>	<b>RO</b>
4F-4C	GPO Port Output Value	<b>03FF FFFF</b>	RW
50-FF	-reserved-	00	—

**I/O Space System Management Bus Registers**

Offset	System Management Bus	Default	Acc
0	SMBus Host Status	00	<b>WC</b>
1	SMBus Slave Status	00	RW
2	SMBus Host Control	00	RW
3	SMBus Host Command	00	RW
4	SMBus Host Address	00	RW
5	SMBus Host Data 0	00	RW
6	SMBus Host Data 1	00	RW
7	SMBus Block Data	00	RW
8	SMBus Slave Control	00	RW
9	SMBus Shadow Command	00	<b>RO</b>
A-B	SMBus Slave Event	0000	RW
C-D	SMBus Slave Data	0000	<b>RO</b>
E-F	-reserved-	00	—



**I/O Space Hardware Monitor Registers**

Offset	Hardware Monitor	Default	Acc
00-3F	<u>Value RAM</u>		
00-12	-reserved-	00	—
13	Analog Data 15-8	00	RW
14	Analog Data 7-0	00	RW
15	Digital Data 7-0	00	RW
16	Channel Counter	00	RW
17	Data Valid & Channel Indicators	00	RW
18-1C	-reserved-	00	—
1D	TSENS3 Hot Hi Limit	00	RW
1E	TSENS3 Hot Hysteresis Lo Lim	00	RW
1F	TSENS3 (Int) Temp Reading	00	RW
20	TSENS1 (W13) Temp Reading	00	RW
21	TSENS2 (Y13) Temp Reading	00	RW
22	VSENS1 (U13) Voltage Reading	00	RW
23	VSENS2 (V13) Voltage Reading	00	RW
24	Internal Core VCC Voltage Reading	00	RW
25	VSENS3 (W14) Voltage Reading	00	RW
26	VSENS4 (Y14) Voltage Reading	00	RW
27	-reserved- (-12V Voltage Reading)	00	—
28	-reserved- (-5V Voltage Reading)	00	—
29	FAN1 (T12) Count Reading	00	RW
2A	FAN2 (U12) Count Reading	00	RW
2B	VSENS1 (CPU) Voltage High Limit	00	RW
2C	VSENS1 (CPU) Voltage Low Limit	00	RW
2D	VSENS2 (NB) Voltage High Limit	00	RW
2E	VSENS2 (NB) Voltage Low Limit	00	RW
2F	Internal Core VCC High Limit	00	RW
30	Internal Core VCC Low Limit	00	RW
31	VSENS3 (5V) Voltage High Limit	00	RW
32	VSENS3 (5V) Voltage Low Limit	00	RW
33	VSENS4 (12V) Voltage High Limit	00	RW
34	VSENS4 (12V) Voltage Low Limit	00	RW
35	-reserved- (-12V Sense High Limit)	00	—
36	-reserved- (-12V Sense Low Limit)	00	—
37	-reserved- (-5V Sense High Limit)	00	—
38	-reserved- (-5V Sense Low Limit)	00	—
39	TSENS1 Hot High Limit	00	RW
3A	TSENS1 Hot Hysteresis Lo Lim	00	RW
3B	FAN1 Fan Count Limit	00	RW
3C	FAN2 Fan Count Limit	00	RW
3D	TSENS2 Hot High Limit	00	RW
3E	TSENS2 Hot Hysteresis Lo Lim	00	RW
3F	Stepping ID Number	00	RW

Offset	Hardware Monitor (continued)	Default	Acc
40	Hardware Monitor Configuration	<b>08</b>	RW
41	Hardware Monitor Interrupt Status 1	00	<b>RO</b>
42	Hardware Monitor Interrupt Status 2	00	<b>RO</b>
43	Hardware Monitor Interrupt Mask 1	00	RW
44	Hardware Monitor Interrupt Mask 2	00	RW
45-46	-reserved-	00	—
47	Hardware Monitor Fan Configuration	<b>50</b>	RW
48	-reserved-	00	—
49	HW Mon Temp Value Lo-Order Bits	00	RW
4A	-reserved-	00	—
4B	Temperature Interrupt Configuration	<b>15</b>	RW
4C-FF	-reserved-	00	—

**PCI Function 5 & 6 Registers – AC97 / MC97 Codecs**
**Function 5 Configuration Space AC97 Header Registers**

Offset	PCI Configuration Space Header	Default	Acc
1-0	Vendor ID	<b>1106</b>	RO
3-2	Device ID	<b>3058</b>	RO
5-4	Command	0000	<b>RW</b>
7-6	Status	<b>0210</b>	<b>WC</b>
8	Revision ID	<b>nn</b>	RO
9	Programming Interface	00	RO
A	Sub Class Code	<b>01</b>	RO
B	Base Class Code	<b>04</b>	RO
C	Cache Line Size	00	RO
D	Latency Timer	00	<b>RW</b>
E	Header Type	00	RO
F	BIST	00	RO
13-10	Base Address 0 - SGD Control/Status	<b>0000 0001</b>	<b>RW</b>
17-14	Base Address 1 - FM NMI Status	<b>0000 0001</b>	<b>RW</b>
1B-18	Base Address 2 - MIDI Port (CF/CG)	0000 0000	<b>RW</b>
1F-1C	Base Address 3 (reserved)	0000 0000	—
23-20	Base Address 4 (reserved)	0000 0000	—
27-24	Base Address 5 (reserved)	0000 0000	—
28-29	-reserved-	00	—
2F-2C	Subsys ID / SubVendor ID (CF/CG)	0000 0000	<b>RW</b>
33-30	Expansion ROM (reserved)	0000 0000	—
34	Capture Pointer (CF/CG)	00	<b>RW</b>
35-3B	-reserved-	00	—
3C	Interrupt Line	00	<b>RW</b>
3D	Interrupt Pin	<b>03</b>	RO
3E-3F	-reserved-	00	—

**Configuration Space Audio Codec-Specific Registers**

Offset	Audio Codec Link Control	Default	Acc
40	AC-Link Interface Status	00	<b>RO</b>
41	AC-Link Interface Control	00	RW
42	Function Enable	00	RW
43	Plug and Play Control	<b>1C</b>	RW
44	MC97 Interface Control	00	<b>RO</b>
45-47	-reserved-	00	—
48	FM NMI Control	00	<b>RO</b>
49	-reserved-	00	—
4B-4A	Game Port Base Address	0000	RW
4C-FF	-reserved-	00	—

Note that these registers are the same as function 6 except for offset 44 (Read / Write in function 6)

**Function 6 Configuration Space MC97 Header Registers**

Offset	PCI Configuration Space Header	Default	Acc
1-0	Vendor ID	<b>1106</b>	RO
3-2	Device ID	<b>3068</b>	RO
5-4	Command	0000	<b>RW</b>
7-6	Status	<b>0200</b>	<b>WC</b>
8	Revision ID	<b>nn</b>	RO
9	Programming Interface	00	RO
A	Sub Class Code	<b>80</b>	RO
B	Base Class Code	<b>07</b>	RO
C	Cache Line Size	00	RO
D	Latency Timer	00	<b>RW</b>
E	Header Type	00	RO
F	BIST	00	RO
13-10	Base Address 0 - SGD Control/Status	<b>0000 0001</b>	<b>RW</b>
17-14	Base Address 1 - FM NMI Status	<b>0000 0001</b>	<b>RW</b>
1B-18	Base Address 2 - MIDI Port (CF/CG)	0000 0000	<b>RW</b>
1F-1C	Base Address 3 (reserved)	0000 0000	—
23-20	Base Address 4 (reserved)	0000 0000	—
27-24	Base Address 5 (reserved)	0000 0000	—
28-29	-reserved-	00	—
2F-2C	Subsys ID / SubVendor ID (CF/CG)	0000 0000	<b>RW</b>
33-30	Expansion ROM (reserved)	0000 0000	—
34	Capture Pointer (CF/CG)	00	<b>RW</b>
35-3B	-reserved-	00	—
3C	Interrupt Line	00	<b>RW</b>
3D	Interrupt Pin	<b>03</b>	RO
3E-3F	-reserved-	00	—

**Configuration Space Modem Codec-Specific Registers**

Offset	Modem Codec Link Control	Default	Acc
40	AC-Link Interface Status	00	<b>RO</b>
41	AC-Link Interface Control	00	RW
42	Function Enable	00	RW
43	Plug and Play Control	<b>1C</b>	RW
44	MC97 Interface Control	00	RW
45-47	-reserved-	00	—
48	FM NMI Control	00	<b>RO</b>
49	-reserved-	00	—
4B-4A	Game Port Base Address	0000	<b>RO</b>
4C-FF	-reserved-	00	—

Note that these registers are the same as function 5 except for offset 44 (Read Only in function 5)

**Function 5 I/O Base 0 Registers – AC97 Audio S/G DMA**

Offset	AC97 SGD I/O Registers	Default	Acc
0	SGD Read Channel Status	00	WC
1	SGD Read Channel Control	00	RW
2	SGD Read Channel Type	00	RW
3	-reserved-	00	—
7-4	SGD Read Chan Table Pointer Base SGD Read Channel Current Address	0000 0000	WR RD
B-8	Reserved (Test)	0000 0000	RO
F-C	SGD Read Chan Current Count	0000 0000	RO
10	SGD Write Channel Status	00	WC
11	SGD Write Channel Control	00	RW
12	SGD Write Channel Type	00	RW
13	-reserved-	00	—
17-14	SGD Write Chan Table Pointer Base SGD Write Channel Current Address	0000 0000	WR RD
1B-18	Reserved (Test)	0000 0000	RO
1F-1C	SGD Write Channel Current Count	0000 0000	RO
20	SGD FM Channel Status	00	WC
21	SGD FM Channel Control	00	RW
22	SGD FM Type	00	RW
23	-reserved-	00	—
27-24	SGD FM Channel Table Pointer Base SGD FM Channel Current Address	0000 0000	WR RD
2B-28	Reserved (Test)	0000 0000	RO
2F-2C	SGD FM Channel Current Count	0000 0000	RO
30-7F	-reserved-	00	—
Offset	AC97 / Audio Codec I/O Registers	Default	Acc
83-80	AC97 Controller Command / Status	0000 0000	RW
87-84	SGD Status Shadow	0000 0000	RO
88-FF	-reserved-	00	—

**Function 5 I/O Base 1 Registers – FM NMI Status**

Offset	FM NMI Status Registers	Default	Acc
0	FM NMI Status	00	RO
1	FM NMI Data	00	RO
2	FM NMI Index	00	RO
3	-reserved-	00	—

**Function 5 I/O Base 2 Registers – MIDI / Game Port**

Offset	FM NMI Status Registers	Default	Acc
1-0	MIDI Port Base	0330	RW
3-2	Game Port Base	0200	RW

**Function 6 I/O Base 0 Registers – MC97 Modem S/G DMA**

Offset	MC97 SGD I/O Registers	Default	Acc
40	SGD Read Channel Status	00	WC
41	SGD Read Channel Control	00	RW
42	SGD Read Channel Type	00	RW
43	-reserved-	00	—
47-44	SGD Read Chan Table Pointer Base SGD Read Channel Current Address	0000 0000	WR RD
4B-48	-reserved- (Test)	0000 0000	RO
4F-4C	SGD Read Chan Current Count	0000 0000	RO
50	SGD Write Channel Status	00	WC
51	SGD Write Channel Control	00	RW
52	SGD Write Channel Type	00	RW
53	-reserved-	00	—
57-54	SGD Write Chan Table Pointer Base SGD Write Channel Current Address	0000 0000	WR RD
5B-58	Reserved (Test)	0000 0000	RO
5F-5C	SGD Write Channel Current Count	0000 0000	RO
60-7F	-reserved-	00	—
Offset	AC97 / Modem Codec I/O Registers	Default	Acc
83-80	AC97 Controller Command / Status	0000 0000	RW
87-84	SGD Status Shadow	0000 0000	RO
8B-88	Modem Codec GPI Intr Status / GPIO	0000 0000	WC
8F-8C	Modem Codec GPI Interrupt Enable	0000 0000	RW
90-FF	-reserved-	00	—

**I/O Registers – SoundBlaster Pro**

<b>Offset</b>	<b>SB Pro Registers (220 or 240h typ)</b>	<b>Default</b>	<b>Acc</b>
0	FM Left Channel Index / Status		RW
1	FM Left Channel Data		<b>WO</b>
2	FM Right Channel Index / Status		RW
3	FM Right Channel Data		<b>WO</b>
4	Mixer Index		<b>WO</b>
5	Mixer Data		RW
6	Sound Processor Reset		<b>WO</b>
7	-reserved-	00	--
8	FM Index / Status (Both Channels)		RW
9	FM Data (Both Channels)		<b>WO</b>
A	Sound Processor Data		<b>RO</b>
B	-reserved-	00	--
C	Sound Processor Command / Data Sound Processor Buffer Status		WR RD
D	-reserved-	00	--
E	Snd Processor Data Available Status		<b>RO</b>
F	-reserved-	00	--

<b>Port</b>	<b>SB Pro Regs (same as offsets 8 &amp; 9)</b>	<b>Default</b>	<b>Acc</b>
388h	FM Index / Status		RW
389h	FM Data		<b>WO</b>

The above group of registers emulates the “FM”, “Mixer”, and “Sound Processor” functions of the SoundBlaster Pro.

**I/O Registers – Game Port**

<b>Offset</b>	<b>Game Port (200-20F typical)</b>	<b>Default</b>	<b>Acc</b>
0	-reserved-	00	--
1	Game Port Status		<b>RO</b>
1	Start One-Shot		<b>WO</b>
2-F	-reserved-	00	--

**Register Descriptions**

**Legacy I/O Ports**

This group of registers includes the DMA Controllers, Interrupt Controllers, and Timer/Counters as well as a number of miscellaneous ports originally implemented using discrete logic on original PC/AT motherboards. All of the registers listed are integrated on-chip. These registers are implemented in a precise manner for backwards compatibility with previous generations of PC hardware. These registers are listed for information purposes only. Detailed descriptions of the actions and programming of these registers are included in numerous industry publications (duplication of that information here is beyond the scope of this document). All of these registers reside in I/O space.

**Port 61 - Misc Functions & Speaker Control..... RW**

- 7 **Reserved** ..... always reads 0
- 6 **IOCHCK# Active** .....RO  
This bit is set when the ISA bus IOCHCK# signal is asserted. Once set, this bit may be cleared by setting bit-3 of this register. Bit-3 should be cleared to enable recording of the next IOCHCK#. IOCHCK# generates NMI to the CPU if NMI is enabled.
- 5 **Timer/Counter 2 Output**.....RO  
This bit reflects the output of Timer/Counter 2 without any synchronization.
- 4 **Refresh Detected**.....RO  
This bit toggles on every rising edge of the ISA bus REFRESH# signal.
- 3 **IOCHCK# Disable**.....RW  
0 Enable IOCHCK# assertions ..... default  
1 Force IOCHCK# inactive and clear any "IOCHCK# Active" condition in bit-6
- 2 **Reserved** .....RW, default=0
- 1 **Speaker Enable**.....RW  
0 Disable..... default  
1 Enable Timer/Ctr 2 output to drive SPKR pin
- 0 **Timer/Counter 2 Enable** .....RW  
0 Disable..... default  
1 Enable Timer/Counter 2

**Port 92h - System Control..... RW**

- 7-6 **Hard Disk Activity LED Status**  
0 Off ..... default  
1-3 On
- 5-4 **Reserved** ..... always reads 0
- 3 **Power-On Password Bytes Inaccessible** ..default=0
- 2 **Reserved** ..... always reads 0
- 1 **A20 Address Line Enable**  
0 A20 disable / forced 0 (real mode) ..... default  
1 A20 address line enable
- 0 **High Speed Reset**  
0 Normal  
1 Briefly pulse system reset to switch from protected mode to real mode

**Keyboard Controller Registers**

The keyboard controller handles the keyboard and mouse interfaces. Two ports are used: port 60 and port 64. Reads from port 64 return a status byte. Writes to port 64h are command codes (see command code list following the register descriptions). Input and output data is transferred via port 60.

A “Control” register is also available. It is accessible by writing commands 20h / 60h to the command port (port 64h); The control byte is written by first sending 60h to the command port, then sending the control byte value. The control register may be read by sending a command of 20h to port 64h, waiting for “Output Buffer Full” status = 1, then reading the control byte value from port 60h.

Traditional (non-integrated) keyboard controllers have an “Input Port” and an “Output Port” with specific pins dedicated to certain functions and other pins available for general purpose I/O. Specific commands are provided to set these pins high and low. All outputs are “open-collector” so to allow input on one of these pins, the output value for that pin would be set high (non-driving) and the desired input value read on the input port. These ports are defined as follows:

Bit	Input Port	Lo Code	Hi Code
0	P10 - Keyboard Data In	B0	B8
1	P11 - Mouse Data In	B1	B9
2	P12 - Turbo Pin (PS/2 mode only)	B2	BA
3	P13 - user-defined	B3	BB
4	P14 - user-defined	B6	BE
5	P15 - user-defined	B7	BF
6	P16 - user-defined	-	-
7	P17 - undefined	-	-

Bit	Output Port	Lo Code	Hi Code
0	P20 - SYSRST (1=execute reset)	-	-
1	P21 - GATEA20 (1=A20 enabled)	-	-
2	P22 - Mouse Data Out	B4	BC
3	P23 - Mouse Clock Out	B5	BD
4	P24 - Keyboard OBF Interrupt (IRQ1)	-	-
5	P25 - Mouse OBF Interrupt (IRQ 12)	-	-
6	P26 - Keyboard Clock Out	-	-
7	P27 - Keyboard Data Out	-	-

Bit	Test Port	Lo Code	Hi Code
0	T0 - Keyboard Clock In	-	-
1	T1 - Mouse Clock In	-	-

Note: Command code C0h transfers input port data to the output buffer. Command code D0h copies output port values to the output buffer. Command code E0h transfers test input port data to the output buffer.

**Port 60 - Keyboard Controller Input Buffer ..... WO**

Only write to port 60h if port 64h bit-1 = 0 (1=full).

**Port 60 - Keyboard Controller Output Buffer .....RO**

Only read from port 60h if port 64h bit-0 = 1 (0=empty).

**Port 64 - Keyboard / Mouse Status ..... RO**

- 7 Parity Error**
  - 0 No parity error (odd parity received)..... default
  - 1 Even parity occurred on last byte received from keyboard / mouse
- 6 General Receive / Transmit Timeout**
  - 0 No error ..... default
  - 1 Error
- 5 Mouse Output Buffer Full**
  - 0 Mouse output buffer empty..... default
  - 1 Mouse output buffer holds mouse data
- 4 Keylock Status**
  - 0 Locked
  - 1 Free
- 3 Command / Data**
  - 0 Last write was data write ..... default
  - 1 Last write was command write
- 2 System Flag**
  - 0 Power-On Default ..... default
  - 1 Self Test Successful
- 1 Input Buffer Full**
  - 0 Input Buffer Empty ..... default
  - 1 Input Buffer Full
- 0 Keyboard Output Buffer Full**
  - 0 Keyboard Output Buffer Empty..... default
  - 1 Keyboard Output Buffer Full

**KBC Control Register .....(R/W via Commands 20h/60h)**

- 7 Reserved** .....always reads 0
- 6 PC Compatibility**
  - 0 Disable scan conversion
  - 1 Convert scan codes to PC format; convert 2-byte break sequences to 1-byte PC-compatible break codes ..... default
- 5 Mouse Disable**
  - 0 Enable Mouse Interface ..... default
  - 1 Disable Mouse Interface
- 4 Keyboard Disable**
  - 0 Enable Keyboard Interface ..... default
  - 1 Disable Keyboard Interface
- 3 Reserved** .....always reads 0
- 2 System Flag** .....default=0  
This bit may be read back as status register bit-2
- 1 Mouse Interrupt Enable**
  - 0 Disable mouse interrupts ..... default
  - 1 Generate interrupt on IRQ12 when mouse data comes in output bufer
- 0 Keyboard Interrupt Enable**
  - 0 Disable Keyboard Interrupts..... default
  - 1 Generate interrupt on IRQ1 when output buffer has been written.

**Port 64 - Keyboard / Mouse Command..... WO**

This port is used to send commands to the keyboard / mouse controller. The command codes recognized by the VT82C686A are listed in the table below.

Note: The VT82C686A Keyboard Controller is compatible with the VIA VT82C42 Industry-Standard Keyboard Controller except that due to its integrated nature, many of the input and output port pins are not available externally for use as general purpose I/O pins (even though P13-P16 are set on power-up as strapping options). In other words, many of the commands below are provided and “work”, but otherwise perform no useful function (e.g., commands that set P12-P17 high or low). Also note that setting P10-11, P22-23, P26-27, and T0-1 high or low directly serves no useful purpose, since these bits are used to implement the keyboard and mouse ports and are directly controlled by keyboard controller logic.

**Table 4. Keyboard Controller Command Codes**

<u>Code</u>	<u>Keyboard Command Code Description</u>	<u>Code</u>	<u>Keyboard Command Code Description</u>
20h	Read Control Byte (next byte is Control Byte)	C0h	Read input port (read P10-17 input data to the output buffer)
21-3Fh	Read SRAM Data (next byte is Data Byte)	C1h	Poll input port low (read input data on P11-13 repeatedly & put in bits 5-7 of status)
60h	Write Control Byte (next byte is Control Byte)	C2h	Poll input port high (same except P15-17)
61-7Fh	Write SRAM Data (next byte is Data Byte)	C8h	Unblock P22-23 (use before D1 to change active mode)
9xh	Write low nibble (bits 0-3) to P10-P13	C9h	Reblock P22-23 (protection mechanism for D1)
A1h	Output Keyboard Controller Version #	CAh	Read mode (output KBC mode info to port 60 output buffer (bit-0=0 if ISA, 1 if PS/2))
A4h	Test if Password is installed (always returns F1h to indicate not installed)	D0h	Read Output Port (copy P10-17 output port values to port 60)
A7h	Disable Mouse Interface	D1h	Write Output Port (data byte following is written to keyboard output port as if it came from keyboard)
A8h	Enable Mouse Interface	D2h	Write Keyboard Output Buffer & clear status bit-5 (write following byte to keyboard)
A9h	Mouse Interface Test (puts test results in port 60h) (value: 0=OK, 1=clk stuck low, 2=clk stuck high, 3=data stuck lo, 4=data stuck hi, FF=general error)	D3h	Write Mouse Output Buffer & set status bit-5 (write following byte to mouse; put value in mouse input buffer so it appears to have come from the mouse)
AAh	KBC self test (returns 55h if OK, FCh if not)	D4h	Write Mouse (write following byte to mouse)
ABh	Keyboard Interface Test (see A9h Mouse Test)	E0h	Read test inputs (T0-1 read to bits 0-1 of resp byte)
ADh	Disable Keyboard Interface	Exh	Set P23-P21 per command bits 3-1
AEh	Enable Keyboard Interface	Fxh	Pulse P23-P20 low for 6usec per command bits 3-0
AFh	Return Version #		
B0h	Set P10 low		
B1h	Set P11 low		
B2h	Set P12 low		
B3h	Set P13 low		
B4h	Set P22 low		
B5h	Set P23 low		
B6h	Set P14 low		
B7h	Set P15 low		
B8h	Set P10 high		
B9h	Set P11 high		
BAh	Set P12 high		
BBh	Set P13 high		
BCh	Set P22 high		
BDh	Set P23 high		
BEh	Set P14 high		
BFh	Set P15 high		

All other codes not listed are undefined.



**DMA Controller I/O Registers**

**Ports 00-0F - Master DMA Controller**

Channels 0-3 of the Master DMA Controller control System DMA Channels 0-3. There are 16 Master DMA Controller registers:

<u>I/O Address Bits 15-0</u>	<u>Register Name</u>	
0000 0000 000x 0000	Ch 0 Base / Current Address	RW
0000 0000 000x 0001	Ch 0 Base / Current Count	RW
0000 0000 000x 0010	Ch 1 Base / Current Address	RW
0000 0000 000x 0011	Ch 1 Base / Current Count	RW
0000 0000 000x 0100	Ch 2 Base / Current Address	RW
0000 0000 000x 0101	Ch 2 Base / Current Count	RW
0000 0000 000x 0110	Ch 3 Base / Current Address	RW
0000 0000 000x 0111	Ch 3 Base / Current Count	RW
0000 0000 000x 1000	Status / Command	RW
0000 0000 000x 1001	Write Request	WO
0000 0000 000x 1010	Write Single Mask	WO
0000 0000 000x 1011	Write Mode	WO
0000 0000 000x 1100	Clear Byte Pointer F/F	WO
0000 0000 000x 1101	Master Clear	WO
0000 0000 000x 1110	Clear Mask	WO
0000 0000 000x 1111	R/W All Mask Bits	RW

**Ports C0-DF - Slave DMA Controller**

Channels 0-3 of the Slave DMA Controller control System DMA Channels 4-7. There are 16 Slave DMA Controller registers:

<u>I/O Address Bits 15-0</u>	<u>Register Name</u>	
0000 0000 1100 000x	Ch 4 Base / Current Address	RW
0000 0000 1100 001x	Ch 4 Base / Current Count	RW
0000 0000 1100 010x	Ch 5 Base / Current Address	RW
0000 0000 1100 011x	Ch 5 Base / Current Count	RW
0000 0000 1100 100x	Ch 6 Base / Current Address	RW
0000 0000 1100 101x	Ch 6 Base / Current Count	RW
0000 0000 1100 110x	Ch 7 Base / Current Address	RW
0000 0000 1100 111x	Ch 7 Base / Current Count	RW
0000 0000 1101 000x	Status / Command	RW
0000 0000 1101 001x	Write Request	WO
0000 0000 1101 010x	Write Single Mask	WO
0000 0000 1101 011x	Write Mode	WO
0000 0000 1101 100x	Clear Byte Pointer F/F	WO
0000 0000 1101 101x	Master Clear	WO
0000 0000 1101 110x	Clear Mask	WO
0000 0000 1101 111x	Read/Write All Mask Bits	WO

Note that not all bits of the address are decoded.

The Master and Slave DMA Controllers are compatible with the Intel 8237 DMA Controller chip. Detailed description of 8237 DMA controller operation can be obtained from the Intel Peripheral Components Data Book and numerous other industry publications.

**Ports 80-8F - DMA Page Registers**

There are eight DMA Page Registers, one for each DMA channel. These registers provide bits 16-23 of the 24-bit address for each DMA channel (bits 0-15 are stored in registers in the Master and Slave DMA Controllers). They are located at the following I/O Port addresses:

<u>I/O Address Bits 15-0</u>	<u>Register Name</u>	
0000 0000 1000 0111	Channel 0 DMA Page (M-0).....	RW
0000 0000 1000 0011	Channel 1 DMA Page (M-1).....	RW
0000 0000 1000 0001	Channel 2 DMA Page (M-2).....	RW
0000 0000 1000 0010	Channel 3 DMA Page (M-3).....	RW
0000 0000 1000 1111	Channel 4 DMA Page (S-0) .....	RW
0000 0000 1000 1011	Channel 5 DMA Page (S-1) .....	RW
0000 0000 1000 1001	Channel 6 DMA Page (S-2) .....	RW
0000 0000 1000 1010	Channel 7 DMA Page (S-3) .....	RW

**DMA Controller Shadow Registers**

The DMA Controller shadow registers are enabled by setting function 0 Rx77 bit 0. If the shadow registers are enabled, they are read back at the indicated I/O port instead of the standard DMA controller registers (writes are unchanged).

- Port 0 –Channel 0 Base Address ..... RO**
- Port 1 –Channel 0 Byte Count ..... RO**
- Port 2 –Channel 1 Base Address ..... RO**
- Port 3 –Channel 1 Byte Count ..... RO**
- Port 4 –Channel 2 Base Address ..... RO**
- Port 5 –Channel 2 Byte Count ..... RO**
- Port 6 –Channel 3 Base Address ..... RO**
- Port 7 –Channel 3 Byte Count ..... RO**
- Port 8 –1<sup>st</sup> Read Channel 0-3 Command Register ..... RO**
- Port 8 –2<sup>nd</sup> Read Channel 0-3 Request Register ..... RO**
- Port 8 –3<sup>rd</sup> Read Channel 0 Mode Register ..... RO**
- Port 8 –4<sup>th</sup> Read Channel 1 Mode Register ..... RO**
- Port 8 –5<sup>th</sup> Read Channel 2 Mode Register ..... RO**
- Port 8 –6<sup>th</sup> Read Channel 3 Mode Register ..... RO**
- Port F –Channel 0-3 Read All Mask ..... RO**
- Port C4 –Channel 5 Base Address ..... RO**
- Port C6 –Channel 5 Byte Count ..... RO**
- Port C8 –Channel 6 Base Address ..... RO**
- Port CA –Channel 6 Byte Count ..... RO**
- Port CC –Channel 7 Base Address ..... RO**
- Port CE –Channel 7 Byte Count ..... RO**
- Port D0 –1<sup>st</sup> Read Channel 4-7 Command Register ..... RO**
- Port D0 –2<sup>nd</sup> Read Channel 4-7 Request Register ..... RO**
- Port D0 –3<sup>rd</sup> Read Channel 4 Mode Register ..... RO**
- Port D0 –4<sup>th</sup> Read Channel 5 Mode Register ..... RO**
- Port D0 –5<sup>th</sup> Read Channel 6 Mode Register ..... RO**
- Port D0 –6<sup>th</sup> Read Channel 7 Mode Register ..... RO**
- Port DE –Channel 4-7 Read All Mask ..... RO**

**Interrupt Controller Registers**

**Ports 20-21 - Master Interrupt Controller**

The Master Interrupt Controller controls system interrupt channels 0-7. Two registers control the Master Interrupt Controller. They are:

<u>I/O Address Bits 15-0</u>	<u>Register Name</u>	
0000 0000 001x xxx0	Master Interrupt Control	RW
0000 0000 001x xxx1	Master Interrupt Mask	RW

Note that not all bits of the address are decoded.

The Master Interrupt Controller is compatible with the Intel 8259 Interrupt Controller chip. Detailed descriptions of 8259 Interrupt Controller operation can be obtained from the Intel Peripheral Components Data Book and numerous other industry publications.

**Ports A0-A1 - Slave Interrupt Controller**

The Slave Interrupt Controller controls system interrupt channels 8-15. The slave system interrupt controller also occupies two register locations:

<u>I/O Address Bits 15-0</u>	<u>Register Name</u>	
0000 0000 101x xxx0	Slave Interrupt Control	RW
0000 0000 101x xxx1	Slave Interrupt Mask	RW

Note that not all address bits are decoded.

The Slave Interrupt Controller is compatible with the Intel 8259 Interrupt Controller chip. Detailed descriptions of 8259 Interrupt Controller operation can be obtained from the Intel Peripheral Components Data Book and numerous other industry publications.

**Interrupt Controller Shadow Registers**

The following shadow registers are enabled by setting function 0 Rx47[4]. If the shadow registers are enabled, they are read back at the indicated I/O port instead of the standard interrupt controller registers (writes are unchanged).

<b><u>Port 20 - Master Interrupt Control Shadow .....</u></b>		<b>RO</b>
<b><u>Port A0 - Slave Interrupt Control Shadow .....</u></b>		<b>RO</b>
7	Reserved .....	always reads 0
6	OCW3 bit 2 (POLL)	
5	OCW3 bit 0 (RIS)	
4	OCW3 bit 5 (SMM)	
3	OCW2 bit 7 (R)	
2	ICW4 bit 4 (SFNM)	
1	ICW4 bit 1 (AEOI)	
0	ICW1 bit 3 (LTIM)	

**Port 21 - Master Interrupt Mask Shadow .....**

<b><u>Port A1 - Slave Interrupt Mask Shadow .....</u></b>		<b>RO</b>
7-5	Reserved .....	always reads 0
4-0	T7-T3 of Interrupt Vector Address	

**Timer / Counter Registers**

**Ports 40-43 - Timer / Counter Registers**

There are 4 Timer / Counter registers:

<u>I/O Address Bits 15-0</u>	<u>Register Name</u>	
0000 0000 010x xx00	Timer / Counter 0 Count	RW
0000 0000 010x xx01	Timer / Counter 1 Count	RW
0000 0000 010x xx10	Timer / Counter 2 Count	RW
0000 0000 010x xx11	Timer / Counter Cmd Mode	WO

Note that not all bits of the address are decoded.

The Timer / Counters are compatible with the Intel 8254 Timer / Counter chip. Detailed descriptions of 8254 Timer / Counter operation can be obtained from the Intel Peripheral Components Data Book and numerous other industry publications.

**Timer / Counter Shadow Registers**

The following shadow registers are enabled for readback by setting function 0 Rx47[4]. If the shadow registers are enabled, they are read back at the indicated I/O port instead of the standard timer / counter registers (writes are unchanged).

<b><u>Port 40 – Counter 0 Base Count Value (LSB 1<sup>st</sup> MSB 2<sup>nd</sup>)</u></b>		<b>RO</b>
<b><u>Port 41 – Counter 1 Base Count Value (LSB 1<sup>st</sup> MSB 2<sup>nd</sup>)</u></b>		<b>RO</b>
<b><u>Port 42 – Counter 2 Base Count Value (LSB 1<sup>st</sup> MSB 2<sup>nd</sup>)</u></b>		<b>RO</b>

**CMOS / RTC Registers**

**Port 70 - CMOS Address.....RW**

7 NMI Disable..... RW

0 Enable NMI Generation. NMI is asserted on encountering IOCHCK# on the ISA bus or SERR# on the PCI bus.

1 Disable NMI Generation .....default

6-0 CMOS Address (lower 128 bytes)..... RW

**Port 71 - CMOS Data.....RW**

7-0 CMOS Data (128 bytes)

Note: Ports 70-71 may be accessed if Rx5A bit-2 is set to one to select the internal RTC. If Rx5A bit-2 is set to zero, accesses to ports 70-71 will be directed to an external RTC.

**Port 72 - CMOS Address.....RW**

7-0 CMOS Address (256 bytes)..... RW

**Port 73 - CMOS Data.....RW**

7-0 CMOS Data (256 bytes)

Note: Ports 72-73 may be accessed if Rx5A bit-2 is set to one to select the internal RTC. If Rx5A bit-2 is set to zero, accesses to ports 72-73 will be directed to an external RTC.

**Port 74 - CMOS Address.....RW**

7-0 CMOS Address (256 bytes)..... RW

**Port 75 - CMOS Data.....RW**

7-0 CMOS Data (256 bytes)

Note: Ports 74-75 may be accessed only if Function 0 Rx5B bit-1 is set to one to enable the internal RTC SRAM and if Rx48 bit-3 (Port 74/75 Access Enable) is set to one to enable port 74/75 access.

Note: Ports 70-71 are compatible with PC industry-standards and may be used to access the lower 128 bytes of the 256-byte on-chip CMOS RAM. Ports 72-73 may be used to access the full extended 256-byte space. Ports 74-75 may be used to access the full on-chip extended 256-byte space in cases where the on-chip RTC is disabled.

Note: The system Real Time Clock (RTC) is part of the “CMOS” block. The RTC control registers are located at specific offsets in the CMOS data area (0-0Dh and 7D-7Fh). Detailed descriptions of CMOS / RTC operation and programming can be obtained from the VIA VT82887 Data Book or numerous other industry publications. For reference, the definition of the RTC register locations and bits are summarized in the following table:

Offset	Description	Binary Range	BCD Range
00	Seconds	00-3Bh	00-59h
01	Seconds Alarm	00-3Bh	00-59h
02	Minutes	00-3Bh	00-59h
03	Minutes Alarm	00-3Bh	00-59h
04	Hours	am 12hr: 01-1Ch pm 12hr: 81-8Ch 24hr: 00-17h	01-12h 81-92h 00-23h
05	Hours Alarm	am 12hr: 01-1Ch pm 12hr: 81-8Ch 24hr: 00-17h	01-12h 81-92h 00-23h
06	Day of the Week	Sun=1: 01-07h	01-07h
07	Day of the Month	01-1Fh	01-31h
08	Month	01-0Ch	01-12h
09	Year	00-63h	00-99h

**0A Register A**

7	UIP	Update In Progress
6-4	DV2-0	Divide (010=ena osc & keep time)
3-0	RS3-0	Rate Select for Periodic Interrupt

**0B Register B**

7	SET	Inhibit Update Transfers
6	PIE	Periodic Interrupt Enable
5	AIE	Alarm Interrupt Enable
4	UIE	Update Ended Interrupt Enable
3	SQWE	No function (read/write bit)
2	DM	Data Mode (0=BCD, 1=binary)
1	24/12	Hours Byte Format (0=12, 1=24)
0	DSE	Daylight Savings Enable

**0C Register C**

7	IRQF	Interrupt Request Flag
6	PF	Periodic Interrupt Flag
5	AF	Alarm Interrupt Flag
4	UF	Update Ended Flag
3-0	0	Unused (always read 0)

**0D Register D**

7	VRT	Reads 1 if VBAT voltage is OK
6-0	0	Unused (always read 0)

**0E-7C Software-Defined Storage Registers (111 Bytes)**

Offset	Extended Functions	Binary Range	BCD Range
7D	Date Alarm	01-1Fh	01-31h
7E	Month Alarm	01-0Ch	01-12h
7F	Century Field	13-14h	19-20h

**80-FF Software-Defined Storage Registers (128 Bytes)**

**Table 5. CMOS Register Summary**

**Super-I/O Configuration Index / Data Registers**

Super-I/O configuration registers are accessed by performing I/O operations to / from an index / data pair of registers in system I/O space at port addresses 3F0h and 3F1h. The configuration registers accessed using this mechanism are used to configure the Super-I/O registers (parallel port, serial ports, IR port, and floppy controller).

Super I/O configuration is accomplished in three steps:

- 1) Enter configuration mode (set Function 0 Rx85[1] = 1)
- 2) Configure the chip
  - a) Write index to port 3F0
  - b) Read / write data from / to port 3F1
  - c) Repeat a and b for all desired registers
- 3) Exit configuration mode (set Function 0 Rx85[1] = 0)

**Port 3F0h – Super-I/O Configuration Index.....RW**

**7-0 Index value**

Function 0 PCI configuration space register Rx85[1] must be set to 1 to enable access to the Super-I/O configuration registers.

**Port 3F1h – Super-I/O Configuration Data.....RW**

**7-0 Data value**

This register shares a port with the Floppy Status Port (which is read only). This port is accessible only when Rx85[1] is set to 1 (the floppy status port is accessed if Rx85[1] = 0).

**Super-I/O Configuration Registers**

These registers are accessed via the port 3F0 / 3F1 index / data register pair using the indicated index values below

**Index E0 – Super-I/O Device ID (3Ch)..... RO**

**7-0 Super-I/O ID** ..... default = 3Ch

**Index E1 – Super-I/O Device Revision (00h)..... RO**

**7-0 Super-I/O Revision Code** ..... default = 0

**Index E2 – Super-I/O Function Select (03h)..... RW**

**7-5 Reserved** ..... always reads 0

**4 Floppy Controller Enable**

0 Disable..... default  
1 Enable

**3 Serial Port 2 Enable**

0 Disable..... default  
1 Enable

**2 Serial Port 1 Enable**

0 Disable..... default  
1 Enable

**1-0 Parallel Port Mode / Enable**

00 Unidirectional mode  
01 ECP  
10 EPP  
11 Parallel Port Disable ..... default

**Index E3 – Floppy Controller I/O Base Address (00h).. RW**

**7-2 I/O Address 9-4**..... default = 0

**1-0 Must be 0** ..... default = 0

**Index E6 – Parallel Port I/O Base Address (00h)..... RW**

**7-0 I/O Address 9-2**..... default = 0

If EPP is not enabled, the parallel port can be set to 192 locations on 4-byte boundaries from 100h to 3FCh. If EPP is enabled, the parallel port can be set to 96 locations on 8-byte boundaries from 100h to 3F8h.

**Index E7 – Serial Port 1 I/O Base Address (00h)..... RW**

**7-1 I/O Address 9-3**..... default = 0

**0 Must be 0** ..... default = 0

**Index E8 – Serial Port 2 I/O Base Address (00h)..... RW**

**7-1 I/O Address 9-3**..... default = 0

**0 Must be 0** ..... default = 0

**Index EE – Serial Port Configuration (00h) .....RW**

- 7 Serial Port 2 High Speed Enable**
  - 0 Disable .....default
  - 1 Enable
- 6 Serial Port 1 High Speed Enable**
  - 0 Disable .....default
  - 1 Enable
- 5-3 Serial Port 2 Mode**
  - 000 Standard .....default
  - 001 IrDA (HIPSIR)
  - 010 Amplitude shift keyed IR @ 500KHz
  - 011 -reserved-
  - 1xx -reserved-
- 2 Serial Port 2 Half Duplex**
  - 0 Disable .....default
  - 1 Enable
- 1 Serial Port 2 TX Output Inversion**
  - 0 Disable .....default
  - 1 Enable
- 0 Serial Port 2 RX Input Inversion**
  - 0 Disable .....default
  - 1 Enable

**Index EF – Power Down Control (00h).....RW**

- 7-6 Reserved** ..... always reads 0
- 5 Clock Power Down**
  - 0 Normal operation .....default
  - 1 Power Down
- 4 Parallel Port Power Down**
  - 0 Normal operation .....default
  - 1 Power Down
- 3 Serial Port 2 Power Down**
  - 0 Normal operation .....default
  - 1 Power Down
- 2 Serial Port 1 Power Down**
  - 0 Normal operation .....default
  - 1 Power Down
- 1 FDC Power Down**
  - 0 Normal operation .....default
  - 1 Power Down
- 0 All Power Down**
  - 0 Normal operation .....default
  - 1 Power Down All

**Index F0 – Parallel Port Control (00h) ..... RW**

- 7 PS2 Type BiDirectional Parallel Port**
  - 0 Disable ..... default
  - 1 Enable
- 6 EPP Direction by Register not by IOW**
  - 0 Disable ..... default
  - 1 Enable
- 5 EPP+ECP**
  - 0 Disable ..... default
  - 1 Enable
- 4 EPP Version**
  - 0 Version 1.9 ..... default
  - 1 Version 1.7
- 3-0 Reserved** .....always reads 0

**Index F1 – Serial Port Control (00h) ..... RW**

- 7-6 Reserved** ..... always reads 0
- 5 IR Loop Back**
  - 0 Disable ..... default
  - 1 Enable
- 4 Serial Port 2 Power-Down State**
  - 0 Normal ..... default
  - 1 Tristate output in power down mode
- 3 Serial Port 1 Power-Down State**
  - 0 Normal ..... default
  - 1 Tristate output in power down mode
- 2 IR Dedicated Pin (IRTX/IRRX) Select**
  - 0 IRTX / IRRX Output from Serial Port 2 ..... def
  - 1 Function 0 Rx76[5] = 0:
    - IRRX output from dedicated pin D12
    - IRTX output from dedicated pin E12
- 1-0 Reserved** .....always reads 0

**Index F2 – Test Mode (Do Not Program) ..... RW**

**Index F4 – Test Mode (Do Not Program) ..... RW**

**Index F6 – Floppy Controller Configuration.....RW**

- 7-6 **Reserved** ..... always reads 0
- 5 **Floppy Drive On Parallel Port (CF/CG)**
  - 0 Parallel Port (SPP) Mode .....default
  - 1 FDC Mode

This bit is used in notebook applications to allow attachment of an external floppy drive using the parallel port I/O connector:

<u>SPP Mode</u>	<u>Pin Type</u>	<u>FDC Mode</u>	<u>Pin Type</u>
STROBE#	I/O	-	n/a
PD0	I/O	INDEX#	I
PD1	I/O	TRK00#	I
PD2	I/O	WRTPRT#	I
PD3	I/O	RDATA#	I
PD4	I/O	DSKCHG#	I
PD5	I/O	-	n/a
PD6	I/O	-	n/a
PD7	I/O	-	n/a
ACK#	I	DS1#	O
BUSY	I	MTR1#	O
PE	I	WDATA#	O
SLCT	I	WGATE#	O
AUTOFD#	I/O	DRVEN0	O
ERROR#	I	HDSEL#	O
PINIT#	I/O	DIR#	O
SLCTIN#	I/O	STEP#	O

- 4 **3-Mode FDD**
  - 0 Disable .....default
  - 1 Enable
- 3 **Reserved** ..... always reads 0
- 2 **Four Floppy Drive Option**
  - 0 Internal 2-Drive Decoder .....default
  - 1 External 4-Drive Decoder
- 1 **FDC DMA Non-Burst**
  - 0 Burst .....default
  - 1 Non-Burst
- 0 **FDC Swap**
  - 0 Disable .....default
  - 1 Enable

**Index F8 – Floppy Drive Control ..... RW**

- 7-6 **Floppy Drive 3** (see table below)
- 5-4 **Floppy Drive 2** (see table below)
- 3-2 **Floppy Drive 1** (see table below)
- 1-0 **Floppy Drive 0** (see table below)

	<u>DRVEN1</u>	<u>DRVEN0</u>
00	DRATE0	DENSEL
01	DRATE0	DRATE1
10	DRATE0	DENSEL#
11	DRATE1	DRATE0



**Super-I/O I/O Ports**

**Floppy Disk Controller Registers**

These registers are located at I/O ports which are offsets from "FDCBase" (index E3h of the Super-I/O configuration registers). FDCBase is typically set to allow these ports to be accessed at the standard floppy disk controller address range of 3F0-3F7h.

**Port FDCBase+2 – FDC Command.....RW**

- 7 **Motor 3 (unused in VT82C686A: no MTR3# pin)**
- 6 **Motor 2 (unused in VT82C686A: no MTR2# pin)**
- 5 **Motor 1**
  - 0 Motor Off
  - 1 Motor On
- 4 **Motor 0**
  - 0 Motor Off
  - 1 Motor On
- 3 **DMA and IRQ Channels**
  - 0 Disable
  - 1 Enable
- 2 **FDC Reset**
  - 0 Execute FDC Reset
  - 1 FDC Enable
- 1-0 **Drive Select**
  - 00 Select Drive 0
  - 01 Select Drive 1
  - 1x -reserved-

**Port FDCBase+4 – FDC Main Status.....RO**

- 7 **Main Request**
  - 0 Data register not ready
  - 1 Data register ready
- 6 **Data Input / Output**
  - 0 CPU => FDC
  - 1 FDC => CPU
- 5 **Non-DMA Mode**
  - 0 FDC in DMA mode
  - 1 FDC not in DMA mode
- 4 **FDC Busy**
  - 0 FDC inactive
  - 1 FDC active
- 3-2 **Reserved** ..... always reads 0
- 1 **Drive 1 Active**
  - 0 Drive inactive
  - 1 Drive performing a positioning change
- 0 **Drive 0 Active**
  - 0 Drive inactive
  - 1 Drive performing a positioning change

**Port FDCBase+4 – FDC Data Rate Select..... WO**

- 7 **Software Reset**
  - 0 Normal operation..... default
  - 1 Execute FDC reset (this bit is self clearing)
- 6 **Power Down**
  - 0 Normal operation..... default
  - 1 Power down FDC logic
- 5 **Reserved** .....always reads 0
- 4-2 **Precompensation Select**  
Selects the amount of write precompensation to be used on the WDATA output:
  - 000 Default ..... default
  - 001 41.7 ns
  - 010 93.3 ns
  - 011 125.0 ns
  - 100 166.7 ns
  - 101 208.3 ns
  - 110 250.0 ns
  - 111 0.0 ns (disable)
- 1-0 **Data Rate**

	MFM	FM	Drive Type
00	500K	250K bps	1.2MB 5" or 1.44 MB 3"
01	300K	150K bps	360KB 5"
10	250K	125K bps	720KB 3" ..... default
11	1M	illegal bps	

Note: these bits are not changed by software reset

**Port FDCBase+5 – FDC Data..... RW**

**Port FDCBase+7 – FDC Disk Change Status..... RW**

- 7 **Disk Change**..... RO
  - 0 Floppy not changed..... default
  - 1 Floppy changed since last instruction
- 6-2 **Undefined** ..... always reads 1's
- 1-0 **Data Rate** ..... WO
  - 00 500 Kbit/sec (1.2MB 5" or 1.44 MB 3" drive)
  - 01 300 Kbit/sec (360KB 5" drive)
  - 10 250 Kbit/sec (720KB 3" drive)
  - 11 1 Mbit/sec



**Parallel Port Registers**

These registers are located at I/O ports which are offsets from “LPTBase” (index E6h of the Super-I/O configuration registers). LPTBase is typically set to allow these ports to be accessed at the standard parallel port address range of 378-37Fh.

**Port LPTBase+0 – Parallel Port Data .....RW**

**7-0 Parallel Port Data**

**Port LPTBase+1 – Parallel Port Status.....RO**

- 7 BUSY#**
  - 0 Printer busy, offline, or error
  - 1 Printer not busy
- 6 ACK#**
  - 0 Data transfer to printer complete
  - 1 Data transfer to printer in progress
- 5 PE**
  - 0 Paper available
  - 1 No paper available
- 4 SLCT**
  - 0 Printer offline
  - 1 Printer online
- 3 ERROR#**
  - 0 Printer error
  - 1 Printer OK
- 2-0 Reserved** ..... always read 1 bits

**Port LPTBase+2 – Parallel Port Control .....RW**

- 7-5 Undefined** ..... always read back 1
- 4 Hardware Interrupt**
  - 0 Disable .....default
  - 1 Enable
- 3 Printer Select**
  - 0 Deselect printer .....default
  - 1 Select printer
- 2 Printer Initialize**
  - 0 Initialize Printer.....default
  - 1 Allow printer to operate normally
- 1 Automatic Line Feed**
  - 0 Host handles line feeds.....default
  - 1 Printer does automatic line feeds
- 0 Strobe**
  - 0 No data transfer .....default
  - 1 Transfer data to printer

**Port LPTBase+3 – Parallel Port EPP Address..... RW**

**Port LPTBase+4 – Parallel Port EPP Data Port 0..... RW**

**Port LPTBase+5 – Parallel Port EPP Data Port 1..... RW**

**Port LPTBase+6 – Parallel Port EPP Data Port 2..... RW**

**Port LPTBase+7 – Parallel Port EPP Data Port 3..... RW**

**Port LPTBase+400h – Parallel Port ECP Data / Cfg A RW**

**Port LPTBase+401h – Parallel Port ECP Config B..... RW**

**Port LPTBase+402h – Parallel Port ECP Extd Ctrl..... RW**

- 7-5 Parallel Port Mode Select**
  - 000 Standard Mode..... default
  - 001 PS/2 Mode
  - 010 FIFO Mode
  - 011 ECP Mode
  - 100 EPP Mode
  - 101 -reserved-
  - 110 -reserved-
  - 111 Configuration Mode
- 4 Parallel Port Interrupt Disable**
  - 0 Enable an interrupt pulse to be generated on the high to low edge of the fault. An interrupt will also be generated if the fault condition is asserted and this bit is written from 1 to 0.
  - 1 Disable the interrupt generated on the asserting edge of the fault condition
- 3 Parallel Port DMA Enable**
  - 0 Disable DMA unconditionally
  - 1 Enable DMA
- 2 Parallel Port Interrupt Pending**
  - 0 Interrupt not pending
  - 1 Interrupt pending (DMA & interrupts disabled)

This bit is set to 1 by hardware and must be written to 0 to re-enable interrupts
- 1 FIFO Full ..... RO**
  - 0 FIFO has at least 1 free byte
  - 1 FIFO full or cannot accept byte
- 0 FIFO Empty ..... RO**
  - 0 FIFO contains at least 1 byte of data
  - 1 FIFO is completely empty

**Serial Port 1 Registers**

These registers are located at I/O ports which are offsets from “COM1Base” (index E7h of the Super-I/O configuration registers). COM1Base is typically set to allow these ports to be accessed at the standard serial port 1 address range of 3F8-3FFh.

**Port COM1Base+0 – Transmit / Receive Buffer .....RW**

**7-0 Serial Data**

**Port COM1Base+1 – Interrupt Enable .....RW**

- 7-4 Undefined .....always read 0
- 3 Interrupt on Handshake Input State Change
- 2 Intr on Parity, Overrun, Framing Error or Break
- 1 Interrupt on Transmit Buffer Empty
- 0 Interrupt on Receive Data Ready

**Port COM1Base+1-0 – Baud Rate Generator Divisor...RW**

- 15-0 Divisor Value for Baud Rate Generator
- Baud Rate = 115,200 / Divisor
- (e.g., setting this register to 1 selects 115.2 Kbaud)

**Port COM1Base+2 – Interrupt Status .....RO**

- 7-3 Undefined .....always read 0
- 2-1 Interrupt ID (0=highest priority)
  - 00 Priority 3 (Handshake Input Changed State)
  - 01 Priority 2 (Transmit Buffer Empty)
  - 10 Priority 1 (Data Received)
  - 11 Priority 0 (Serialization Error or Break)
- 0 Interrupt Pending
  - 0 Interrupt Pending
  - 1 No Interrupt Pending

**Port COM1Base+2 – FIFO Control ..... WO**

**Port COM1Base+3 – UART Control.....RW**

- 7 Divisor Latch Access
  - 0 Access xmit / rcv & int enable regs at 0-1
  - 1 Access baud rate generator divisor latch at 0-1
- 6 Break
  - 0 Break condition off
  - 1 Break condition on
- 5-3 Parity
  - 000 None
  - 001 Odd
  - 011 Even
  - 101 Mark
  - 111 Space
- 2 Stop Bits
  - 0 1
  - 1 2
- 1-0 Data Bits
  - 00 5
  - 01 6
  - 10 7
  - 11 8

**Port COM1Base+4 – Handshake Control ..... RW**

- 7-5 Undefined ..... always read 0
- 4 Loopback Check
  - 0 Normal operation
  - 1 Loopback enable
- 3 General Purpose Output 2 (unused in 82C686A)
- 2 General Purpose Output 1 (unused in 82C686A)
- 1 Request To Send
  - 0 Disable
  - 1 Enable
- 0 Data Terminal Ready
  - 0 Disable
  - 1 Enable

**Port COM1Base+5 – UART Status..... RW**

- 7 Undefined ..... always read 0
- 6 Transmitter Empty
  - 0 1 byte in transmit hold or transmit shift register
  - 1 0 bytes transmit hold and transmit shift regs
- 5 Transmit Buffer Empty
  - 0 1 byte in transmit hold register
  - 1 Transmit hold register empty
- 4 Break Detected
  - 0 No break detected
  - 1 Break detected
- 3 Framing Error Detected
  - 0 No error
  - 1 Error
- 2 Parity Error Detected
  - 0 No error
  - 1 Error
- 1 Overrun Error Detected
  - 0 No error
  - 1 Error
- 0 Received Data Ready
  - 0 No received data available
  - 1 Received data in receiver buffer register

**Port COM1Base+6 – Handshake Status..... RW**

- 7 DCD Status (1=Active, 0=Inactive)
- 6 RI Status (1=Active, 0=Inactive)
- 5 DSR Status (1=Active, 0=Inactive)
- 4 CTS Status (1=Active, 0=Inactive)
- 3 DCD Changed (1=Changed Since Last Read)
- 2 RI Changed (1=Changed Since Last Read)
- 1 DSR Changed (1=Changed Since Last Read)
- 0 CTS Changed (1=Changed Since Last Read)

**Port COM1Base+7 – Scratchpad ..... RW**

- 7 Scratchpad Data

**Serial Port 2 Registers**

These registers are located at I/O ports which are offsets from “COM2Base” (index E8h of the Super-I/O configuration registers). COM2Base is typically set to allow these ports to be accessed at the standard serial port 2 address range of 2F8-2FFh.

**Port COM2Base+0 – Transmit / Receive Buffer .....RW**

**7-0 Serial Data**

**Port COM2Base+1 – Interrupt Enable .....RW**

- 7-4 Undefined .....always read 0
- 3 Interrupt on Handshake Input State Change
- 2 Intr on Parity, Overrun, Framing Error or Break
- 1 Interrupt on Transmit Buffer Empty
- 0 Interrupt on Receive Data Ready

**Port COM2Base+1-0 – Baud Rate Generator Divisor...RW**

**15-0 Divisor Value for Baud Rate Generator**

Baud Rate = 115,200 / Divisor  
(e.g., setting this register to 1 selects 115.2 Kbaud)

**Port COM2Base+2 – Interrupt Status .....RO**

- 7-3 Undefined .....always read 0
- 2-1 Interrupt ID (0=highest priority)
  - 00 Priority 3 (Handshake Input Changed State)
  - 01 Priority 2 (Transmit Buffer Empty)
  - 10 Priority 1 (Data Received)
  - 11 Priority 0 (Serialization Error or Break)
- 0 Interrupt Pending
  - 0 Interrupt Pending
  - 1 No Interrupt Pending

**Port COM2Base+2 – FIFO Control ..... WO**

**Port COM2Base+3 – UART Control.....RW**

- 7 Divisor Latch Access
  - 0 Access xmit / rcv & int enable regs at 0-1
  - 1 Access baud rate generator divisor latch at 0-1
- 6 Break
  - 0 Break condition off
  - 1 Break condition on
- 5-3 Parity
  - 000 None
  - 001 Odd
  - 011 Even
  - 101 Mark
  - 111 Space
- 2 Stop Bits
  - 0 1
  - 1 2
- 1-0 Data Bits
  - 00 5
  - 01 6
  - 10 7
  - 11 8

**Port COM2Base+4 – Handshake Control ..... RW**

- 7-5 Undefined ..... always read 0
- 4 Loopback Check
  - 0 Normal operation
  - 1 Loopback enable
- 3 General Purpose Output 2 (unused in 82C686A)
- 2 General Purpose Output 1 (unused in 82C686A)
- 1 Request To Send
  - 0 Disable
  - 1 Enable
- 0 Data Terminal Ready
  - 0 Disable
  - 1 Enable

**Port COM2Base+5 – UART Status..... RW**

- 7 Undefined ..... always read 0
- 6 Transmitter Empty
  - 0 1 byte in transmit hold or transmit shift register
  - 1 0 bytes transmit hold and transmit shift regs
- 5 Transmit Buffer Empty
  - 0 1 byte in transmit hold register
  - 1 Transmit hold register empty
- 4 Break Detected
  - 0 No break detected
  - 1 Break detected
- 3 Framing Error Detected
  - 0 No error
  - 1 Error
- 2 Parity Error Detected
  - 0 No error
  - 1 Error
- 1 Overrun Error Detected
  - 0 No error
  - 1 Error
- 0 Received Data Ready
  - 0 No received data available
  - 1 Received data in receiver buffer register

**Port COM2Base+6 – Handshake Status..... RW**

- 7 DCD Status (1=Active, 0=Inactive)
- 6 RI Status (1=Active, 0=Inactive)
- 5 DSR Status (1=Active, 0=Inactive)
- 4 CTS Status (1=Active, 0=Inactive)
- 3 DCD Changed (1=Changed Since Last Read)
- 2 RI Changed (1=Changed Since Last Read)
- 1 DSR Changed (1=Changed Since Last Read)
- 0 CTS Changed (1=Changed Since Last Read)

**Port COM2Base+7 – Scratchpad ..... RW**

- 7 Scratchpad Data

**SoundBlaster Pro Port Registers**

These registers are located at offsets from “SBPBase” (defined in Rx43 of Audio Function 5 PCI configuration space). SBPBase is typically set to allow these ports to be accessed at the standard SoundBlaster Pro port address of 220h or 240h.

**FM Registers**

**Port SBPBase+0 – FM Left Channel Index / Status.....RW**

7-0 FM Right Channel Index / Status

**Port SBPBase+1 – FM Left Channel Data..... WO**

7-0 Right Channel FM Data

**Port SBPBase+2 – FM Right Channel Index / Status ....RW**

7-0 FM Right Channel Index / Status

**Port SBPBase+3 – FM Right Channel Data ..... WO**

7-0 Right Channel FM Data

**Port 388h or SBPBase+8 – FM Index / Status .....RW**

7-0 FM Index / Status (Both Channels)

Writing to this port programs both the left and right channels (the write programm port offsets 0 and 2 as well)

**Port 389h or SBPBase+9 – FM Data ..... WO**

7-0 FM Data (Both Channels)

Writing to this port programs both the left and right channels (the write programm port offsets 1 and 3 as well)

**Mixer Registers**

**Port SBPBase+4 – Mixer Index..... WO**

7-0 Mixer Index

**Port SBPBase+5 – Mixer Data .....RW**

7-0 Mixer Data

**Sound Processor Registers**

**Port SBPBase+6 – Sound Processor Reset ..... WO**

0 1 = Sound Processor Reset

**Port SBPBase+A – Sound Processor Read Data .....RO**

7-0 Sound Processor Read Data

**Port SBPBase+C – Sound Processor Command / Data WO**

7-0 Sound Processor Command / Write Data

**Port SBPBase+C – Sound Processor Buffer Status.....RO**

7 1 = Sound Processor Command / Data Port Busy

**Port SBPBase+E – Sound Processor Data Avail Status..RO**

7 1 = Sound Processor Data Available

**Register Summary - FM**

Index	Bit-7	Bit-6	Bit-5	Bit-4	Bit-3	Bit-2	Bit-1	Bit-0	
01	Test								
02	Fast Counter (80 usec)								
03	Slow Counter (320 usec)								
04	IRQ	MFC	MSC				SSSC	SSFC	
08	CSM	SEL							
20-35	AM	VIB	EGT	KSR	Multi				
40-55	KSL		Total Level (TL)						
60-75	Attack Rate (AR)				Decay Rate (DR)				
80-95	Sustain Level (SL)				Release Rate (RR)				
A0-A8	F-Number								
B0-B8			Key	Block			F-Number		
BD	Int	AM	VIB	Ryth	Bass	Snare	Tom	Cym	HiHat
C0-C8					Feedback			FM	
E0-F5							WS		

MFC=Mask Fast Counter SSFC=Start / Stop Fast Counter  
MSC=Mask Slow Counter SSSC=Start / Stop Slow Counter

**Register Summary – Mixer**

Index	Bit-7	Bit-6	Bit-5	Bit-4	Bit-3	Bit-2	Bit-1	Bit-0
00	Data Reset							
02	SP Volume L				SP Volume R			
0A						Mic Vol		
0C			Finp		TFIL	Select		
0E			Fout				ST	
22	General Volume				General Volume			
26	FM Volume L				FM Volume R			
28	CD Volume L				CD Volume R			
2E	Line Volume L				Line Volume R			

Finp = Input Filter  
Fout = Output Filter  
TFIL = Input Filter Type  
ST = Stereo / Mono Mode  
Select = Input Choices (0=Microphone, 1=CD, 3=Line)

**Command Summary – Sound Processor (see next page)**

**Command Summary – Sound Processor**

<b>#</b>	<b>Type</b>	<b>Command</b>
10	Play	8 bits directly
14	Play	8 bits via DMA
91	Play	High-speed 8 bits via DMA
16	Play	2-bit compressed via DMA
17	Play	2-bit compressed via DMA with reference
74	Play	4-bit compressed via DMA
75	Play	4-bit compressed via DMA with reference
76	Play	2.6-bit compressed via DMA
77	Play	2.6-bit compressed via DMA with reference
20	Record	Direct
24	Record	Via DMA
99	Record	High-speed 8 bits via DMA
D1	Speaker	Turn on speaker connection
D3	Speaker	Turn off speaker connection
D8	Speaker	Get speaker setting
40	Misc	Set sample rate
48	Misc	Set block length
80	Misc	Set silence block
D0	Misc	Stop DMA
D4	Misc	Continue DMA
E1	Misc	Get version
30	MIDI	Direct MIDI input
31	MIDI	MIDI input via interrupt
32	MIDI	Direct MIDI input with time stamp
33	MIDI	MIDI input via interrupt with time stamp
34	MIDI	Direct MIDI UART mode
35	MIDI	MIDI UART mode via interrupt
36	MIDI	Direct MIDI UART mode with time stamp
37	MIDI	MIDI UART mode via interrupt with time stamp
38	MIDI	Send MIDI code

**Game Port Registers**

These registers are fixed at the standard game port address of 201h.

**I/O Port 201h – Game Port Status ..... RO**

- 7 Joystick B Button 2 Status**
- 6 Joystick B Button 1 Status**
- 5 Joystick A Button 2 Status**
- 4 Joystick A Button 1 Status**
- 3 Joystick B One-Shot Status for Y-Potentiometer**
- 2 Joystick B One-Shot Status for X-Potentiometer**
- 1 Joystick A One-Shot Status for Y-Potentiometer**
- 0 Joystick A One-Shot Status for X-Potentiometer**

**I/O Port 201h – Start One-Shot..... WO**

- 7-0 (Value Written is Ignored)**

**PCI Configuration Space I/O**

PCI configuration space accesses for functions 0-6 use PCI configuration mechanism 1 (see PCI specification revision 2.2 for more details). The ports respond only to double-word accesses. Byte or word accesses will be passed on unchanged.

**Port CFB-CF8 - Configuration Address .....RW**

**31 Configuration Space Enable**

- 0 Disable .....default
- 1 Convert configuration data port writes to configuration cycles on the PCI bus

**30-24 Reserved** ..... always reads 0

**23-16 PCI Bus Number**

Used to choose a specific PCI bus in the system

**15-11 Device Number**

Used to choose a specific device in the system

**10-8 Function Number**

Used to choose a specific function if the selected device supports multiple functions

**7-2 Register Number**

Used to select a specific DWORD in the device's configuration space

**1-0 Fixed** ..... always reads 0

**Port CFF-CFC - Configuration Data .....RW**

There are 7 "functions" implemented in the VT82C686A:

<b><u>Function #</u></b>	<b><u>Function</u></b>
0	PCI to ISA Bridge
1	IDE Controller
2	USB Controller Ports 0-1
3	USB Controller Ports 2-3
4	Power Management, SMBus & Hardware Monitor
5	AC97 Audio Codec Controller
6	MC97 Modem Codec Controller

The following sections describe the registers and register bits of these functions.

**Function 0 Registers - PCI to ISA Bridge**

All registers are located in the function 0 PCI configuration space of the VT82C686A. These registers are accessed through PCI configuration mechanism #1 via I/O address CF8/CFC.

**PCI Configuration Space Header**

**Offset 1-0 - Vendor ID = 1106h.....RO**

**Offset 3-2 - Device ID = 0686h.....RO**

**Offset 5-4 - Command.....RW**

- 15-8 Reserved ..... always reads 0
- 7 Address / Data Stepping
  - 0 Disable
  - 1 Enable .....default
- 6-4 Reserved ..... always reads 0
- 3 Special Cycle Enable ..... Normally RW†, default = 0
- 2 Bus Master ..... always reads 1
- 1 Memory Space..... Normally RO†, reads as 1
- 0 I/O Space ..... Normally RO†, reads as 1

† If the test bit at offset 46 bit-4 is set, access to the above indicated bits is reversed: bit-3 above becomes read only (reading back 1) and bits 0-1 above become read / write (with a default of 1).

**Offset 7-6 - Status.....RWC**

- 15 Detected Parity Error ..... write one to clear
- 14 Signalled System Error ..... always reads 0
- 13 Signalled Master Abort ..... write one to clear
- 12 Received Target Abort ..... write one to clear
- 11 Signalled Target Abort ..... write one to clear
- 10-9 DEVSEL# Timing ..... fixed at 01 (medium)
- 8 Data Parity Detected..... always reads 0
- 7 Fast Back-to-Back..... always reads 0
- 6-0 Reserved ..... always reads 0

**Offset 8 - Revision ID = nn.....RO**

- 7-0 Revision ID
  - 0x VT82C686
  - 1x VT82C686A

**Offset 9 - Program Interface = 00h.....RO**

**Offset A - Sub Class Code = 01h.....RO**

**Offset B - Class Code = 06h.....RO**

**Offset E - Header Type = 80h.....RO**

- 7-0 Header Type Code ..... 80h (Multifunction Device)

**Offset F - BIST = 00h.....RO**

**Offset 2F-2C - Subsystem ID.....RO**

Use offset 70-73 to change the value returned.

**ISA Bus Control**

**Offset 40 - ISA Bus Control..... RW**

- 7 ISA Command Delay
  - 0 Normal..... default
  - 1 Extra
- 6 Extended ISA Bus Ready
  - 0 Disable..... default
  - 1 Enable
- 5 ISA Slave Wait States
  - 0 4 Wait States..... default
  - 1 5 Wait States
- 4 Chipset I/O Wait States
  - 0 2 Wait States..... default
  - 1 4 Wait States
- 3 I/O Recovery Time
  - 0 Disable..... default
  - 1 Enable
- 2 Extend-ALE
  - 0 Disable..... default
  - 1 Enable
- 1 ROM Wait States
  - 0 1 Wait State ..... default
  - 1 0 Wait States
- 0 ROM Write
  - 0 Disable..... default
  - 1 Enable

**Offset 41 - ISA Test Mode..... RW**

- 7 Bus Refresh Arbitration (do not program) default=0
- 6 Before CG Rev C: XRDY Test Mode ..... default=0  
CG Rev C: I/O Recovery Time
  - 0 Normal..... default
  - 1 Medium (8/13 BCLKs)
- 5 Port 92 Fast Reset
  - 0 Disable..... default
  - 1 Enable
- 4 A20G Emulation (do not program)..... default=0
- 3 Double DMA Clock
  - 0 Disable (DMA Clock = ½ ISA Clock)... default
  - 1 Enable (DMA Clock = ISA Clock)

This function can be enabled for external ISA devices (e.g., advanced Super-IO or FIR controllers) which support 8MHz DMA channels. However, if this bit is set to 1, then all DMA channels will be 8 MHz. If this bit is set to 1 and Rx45[n] is set to 1, then ISA DMA channel ‘n’ will be 16 MHz. Therefore, typically this bit is set to 0 and the appropriate bits of Rx45 should be set to 1 to enable 8 MHz DMA clock only for specific channels that support the higher rate.
- 2 SHOLD Lock During INTA (do not program) def=0
- 1 Refresh Request Test Mode (do not program).def=0
- 0 ISA Refresh
  - 0 Disable..... default
  - 1 Enable

This bit should be set to 1 for ISA compatibility.



**Offset 42 - ISA Clock Control.....RW**

- 7 Latch IO16#**
  - 0 Enable (recommended setting) .....default
  - 1 Disable
- 6 MCS16# Output**
  - 0 Disable .....default
  - 1 Enable
- 5 Master Request Test Mode (do not program)**
  - 0 Disable .....default
  - 1 Enable
- 4 Reserved (Do Not Program) ..... default = 0**
- 3 ISA Clock (BCLK) Select Enable**
  - 0 BCLK = PCICLK/4.....default
  - 1 BCLK selected per bits 2-0
- 2-0 ISA Bus Clock Select (if bit-3 = 1)**
  - 000 BCLK = PCICLK/3.....default
  - 001 BCLK = PCICLK/2
  - 010 BCLK = PCICLK/4
  - 011 BCLK = PCICLK/6
  - 100 BCLK = PCICLK/5
  - 101 BCLK = PCICLK/10
  - 110 BCLK = PCICLK/12
  - 111 BCLK = OSC

Note: Procedure for ISA Clock switching:

- 1) Set bit 3 to 0; 2) Change value of bit 2-0; 3) Set bit 3 to 1

**Offset 43 - ROM Decode Control..... RW**

Setting these bits enables the indicated address range to be included in the ROMCS# decode:

- 7 FFFE0000h-FFFEFFFFh ..... default=0**
- 6 FFF80000h-FFFDFFFFh ..... default=0**
- 5 FFF00000h-FFF7FFFFh (CF/CG)..... default=0**
- 4 000E0000h-000EFFFFh (CF/CG) ..... default=0**
- 5 000E8000h-000EFFFFh (CD/CE) ..... default=0**
- 4 000E0000h-000E7FFFh (CD/CE) ..... default=0**
- 3 000D8000h-000DFFFFh ..... default=0**
- 2 000D0000h-000D7FFFh ..... default=0**
- 1 000C8000h-000CFFFFh ..... default=0**
- 0 000C0000h-000C7FFFh..... default=0**

**Offset 44 - Keyboard Controller Control..... RW**

- 7 KBC Timeout Test (do not program)..... default = 0**
- 6-4 Reserved (do not program) ..... default = 0**
- 3 Mouse Lock Enable**
  - 0 Disable..... default
  - 1 Enable
- 2-1 Reserved (do not program) ..... default = 0**
- 0 Reserved (no function) ..... default = 0**

**Offset 45 - Type F DMA Control ..... RW**

- 7 ISA Master / DMA to PCI Line Buffer**
  - 0 Disable..... default
  - 1 Enable
- 6 DMA type F Timing on Channel 7..... default=0**
- 5 DMA type F Timing on Channel 6..... default=0**
- 4 DMA type F Timing on Channel 5..... default=0**
- 3 DMA type F Timing on Channel 3..... default=0**
- 2 DMA type F Timing on Channel 2..... default=0**
- 1 DMA type F Timing on Channel 1..... default=0**
- 0 DMA type F Timing on Channel 0..... default=0**

Note: For bits 0-6 above, see also Rx41[3]

**Offset 46 - Miscellaneous Control 1.....RW**

- 7 PCI Master Write Wait States**
  - 0 0 Wait States .....default
  - 1 1 Wait State
- 6 Gate INTR**
  - 0 Disable .....default
  - 1 Enable
- 5 Flush Line Buffer for Int or DMA IOR Cycle**
  - 0 Disable .....default
  - 1 Enable
- 4 Config Command Reg Rx04 Access (Test Only)**
  - 0 Normal: Bits 0-1=RO, Bit 3=RW.....default
  - 1 Test Mode: Bits 0-1=RW, Bit-3=RO
- 3 Reserved (do not program)..... default = 0**
- 2 Reserved (no function)..... default = 0**
- 1 PCI Burst Read Interruptability**
  - 0 Allow burst reads to be interrupted by ISA master or DMA.....default
  - 1 Don't allow PCI burst reads to be interrupted
- 0 Posted Memory Write Enable**
  - 0 Disable .....default
  - 1 Enable

The Posted Memory Write function is automatically enabled when Delay Transaction (see Rx47 bit-6) is enabled, independent of the state of this bit.

**Offset 47 - Miscellaneous Control 2 ..... RW**

- 7 CPU Reset Source**
  - 0 Use CPURST as CPU Reset ..... default
  - 1 Use INIT as CPU Reset
- 6 PCI Delay Transaction Enable**
  - 0 Disable..... default
  - 1 Enable

The "Posted Memory Write" function is automatically enabled when this bit is enabled, independent of the state of Rx46 bit-0.
- 5 EISA 4D0/4D1 Port Enable**
  - 0 Disable (ignore ports 4D0-1)..... default
  - 1 Enable (ports 4D0-1 per EISA specification)
- 4 Interrupt Controller Shadow Register Enable**
  - 0 Disable..... default
  - 1 Enable (for test purposes, enable readback of interrupt controller internal functions on I/O reads from ports 20-21, A0-A1, A8-A9, and C8-C9) (Contact VIA Test Engineering department)
- 3 Reserved (always program to 0)..... default = 0**

Note: Always mask this bit. This bit may read back as either 0 or 1 but must always be programmed with 0.
- 2 Write Delay Transaction Time-Out Timer**
  - 0 Disable..... default
  - 1 Enable
- 1 Read Delay Transaction Time-Out Timer**
  - 0 Disable..... default
  - 1 Enable
- 0 Software PCI Reset ..... write 1 to generate PCI reset**

**Offset 48 - Miscellaneous Control 3.....RW**

- 7-4 **Reserved** ..... always reads 0
- 3 **Extra RTC Port 74/75 Enable**
  - 0 Disable .....default
  - 1 Enable
- 2 **Integrated USB Controller Disable**
  - 0 Enable.....default
  - 1 Disable
- 1 **Integrated IDE Controller Disable**
  - 0 Enable.....default
  - 1 Disable
- 0 **512K PCI Memory Decode**
  - 0 Use Rx4E[15-12] to select top of PCI memory
  - 1 Use contents of Rx4E[15-12] plus 512K as top of PCI memory .....default

**Offset 4A - IDE Interrupt Routing .....RW**

- 7 **Wait for PGNT Before Grant to ISA Master / DMA**
  - 0 Disable .....default
  - 1 Enable
- 6 **Bus Select for Access to I/O Devices Below 100h**
  - 0 Access ports 00-FFh via XD bus.....default
  - 1 Access ports 00-FFh via SD bus (applies to external devices only; internal devices such as the mouse controller are not effected)
- 5-4 **Reserved (do not program)** ..... default = 0
- 3-2 **IDE Second Channel IRQ Routing**
  - 00 IRQ14
  - 01 IRQ15.....default
  - 10 IRQ10
  - 11 IRQ11
- 1-0 **IDE Primary Channel IRQ Routing**
  - 00 IRQ14.....default
  - 01 IRQ15
  - 10 IRQ10
  - 11 IRQ11

**4C - ISA DMA/Master Memory Access Control 1 ..... RW**

- 7-0 **PCI Memory Hole Bottom Address**  
These bits correspond to HA[23:16] .....default=0

**4D - ISA DMA/Master Memory Access Control 2 ..... RW**

- 7-0 **PCI Memory Hole Top Address (HA[23:16])**  
These bits correspond to HA[23:16] .....default=0

Note: Access to the memory defined in the PCI memory hole will not be forwarded to PCI. This function is disabled if the top address is less than or equal to the bottom address.

**4F-4E - ISA DMA/Master Memory Access Control 3... RW**

- 15-12 **Top of PCI Memory** for ISA DMA/Master accesses
  - 0000 1M ..... default
  - 0001 2M
  - ... ..
  - 1111 16M

Note: All ISA DMA / Masters that access addresses higher than the top of PCI memory will not be directed to the PCI bus.

- 11 **Forward E0000-EFFFF Accesses to PCI**.....def=0
- 10 **Forward A0000-BFFFF Accesses to PCI** .....def=0
- 9 **Forward 80000-9FFFF Accesses to PCI** .....def=1
- 8 **Forward 00000-7FFFF Accesses to PCI** .....def=1
- 7 **Forward DC000-DFFFF Accesses to PCI** .....def=0
- 6 **Forward D8000-DBFFF Accesses to PCI** .....def=0
- 5 **Forward D4000-D7FFF Accesses to PCI** .....def=0
- 4 **Forward D0000-D3FFF Accesses to PCI** .....def=0
- 3 **Forward CC000-CFFFF Accesses to PCI** .....def=0
- 2 **Forward C8000-CBFFF Accesses to PCI** .....def=0
- 1 **Forward C4000-C7FFF Accesses to PCI** .....def=0
- 0 **Forward C0000-C3FFF Accesses to PCI** .....def=0

**Plug and Play Control**

**Offset 50 – PNP DMA Request Control .....RW**

- 7-4 Reserved ..... default = 0
  - 3-2 PnP Routing for Parallel Port DRQ..... def = DRQ3
  - 1-0 PnP Routing for Floppy DRQ..... def = DRQ2
- DRQ Mapping: 00=DRQ0, 01=DRQ1, 10=DRQ2, 11=DRQ3

**Offset 51 - PNP IRQ Routing 1 .....RW**

- 7-4 PnP Routing for Parallel Port IRQ (see PnP IRQ routing table)
- 3-0 PnP Routing for Floppy IRQ (see PnP IRQ routing table)

**Offset 52 - PNP IRQ Routing 2 .....RW**

- 7-4 PnP Routing for Serial Port 2 IRQ (see PnP IRQ routing table)
- 3-0 PnP Routing for Serial Port 1 IRQ (see PnP IRQ routing table)

**Offset 54 - PCI IRQ Edge / Level Select.....RW**

- 7-4 Reserved ..... always reads 0  
The following bits all default to “level” triggered (0)
- 3 PIRQA# Invert (edge) / Non-invert (level).....(1/0)
- 2 PIRQB# Invert (edge) / Non-invert (level).....(1/0)
- 1 PIRQC# Invert (edge) / Non-invert (level).....(1/0)
- 0 PIRQD# Invert (edge) / Non-invert (level).....(1/0)

Note: PIRQA-D# normally connect to PCI interrupt pins INTA-D# (see pin definitions for more information).

**Offset 55 - PNP IRQ Routing 4 .....RW**

- 7-4 PIRQA# Routing (see PnP IRQ routing table)
- 3-0 Reserved ..... always reads 0

**Offset 56 - PNP IRQ Routing 5 .....RW**

- 7-4 PIRQC# Routing (see PnP IRQ routing table)
- 3-0 PIRQB# Routing (see PnP IRQ routing table)

**Offset 57 - PNP IRQ Routing 6 .....RW**

- 7-4 PIRQD# Routing (see PnP IRQ routing table)
- 3-0 Reserved ..... always reads 0

**PnP IRQ Routing Table**

- 0000 Disable .....default
- 0001 IRQ1
- 0010 Reserved
- 0011 IRQ3
- 0100 IRQ4
- 0101 IRQ5
- 0110 IRQ6
- 0111 IRQ7
- 1000 Reserved
- 1001 IRQ9
- 1010 IRQ10
- 1011 IRQ11
- 1100 IRQ12
- 1101 Reserved
- 1110 IRQ14
- 1111 IRQ15

**Offset 58 – External APIC IRQ Output Control ..... RW**

- 7-5 Reserved .....always reads 0
- 4 ACPI IRQ to APIC[23:16] with Rx42[2:0]
  - 0 Disable..... default
  - 1 Enable
- 3 MC97 IRQ to APIC[23:16] with Rx3C[2:0]
  - 0 Disable..... default
  - 1 Enable
- 2 AC97 IRQ to APIC[23:16] with Rx3C[2:0]
  - 0 Disable..... default
  - 1 Enable
- 1 USB Port 1 IRQ to APIC[23:16] with Rx3C[2:0]
  - 0 Disable..... default
  - 1 Enable
- 0 USB Port 0 IRQ to APIC[23:16] with Rx3C[2:0]
  - 0 Disable..... default
  - 1 Enable

**Offset 59 – PCS0# Control (CF/CG Silicon).....RW**

- 7-4 **Reserved** ..... always reads 0
- 3 **PCS0# Pin Function (Pin T5)**
  - 0 Pin is defined as PCS0# .....default
  - 1 Pin is defined as Internal Trap I/O
- 2-0 **Reserved** ..... always reads 0

**Offset 5A – KBC / RTC Control.....RW**

Bits 7-4 of this register are latched from pins SD7-4 at power-up but are read/write accessible so may be changed after power-up to change the default strap setting:

- 7 **Keyboard RP16** ..... latched from SD7
- 6 **Keyboard RP15** ..... latched from SD6
- 5 **Keyboard RP14** ..... latched from SD5
- 4 **Keyboard RP13** ..... latched from SD4
- 3 **Audio Function Enable**  
..... RO, strapped from SPKR pin V5
  - 0 Disable (SDD pins function as SDD)
  - 1 Enable (SDD pins function as Audio / Game)
- 2 **Internal RTC Enable**
  - 0 Disable
  - 1 Enable .....default
- 1 **Internal PS2 Mouse Enable**
  - 0 Disable .....default
  - 1 Enable
- 0 **Internal KBC Enable**
  - 0 Disable .....default
  - 1 Enable

Note: External strap option values may be set by connecting the indicated external pin to a 4.7K ohm pullup (for 1) or driving it low during reset with a 7407 TTL open collector buffer (for 0) as shown in the suggested circuit below:

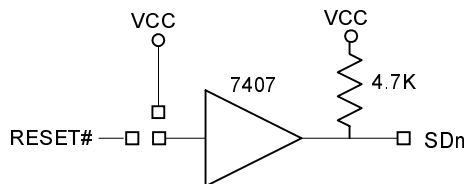

Figure 5. Strap Option Circuit

**Offset 5B - Internal RTC Test Mode ..... RW**

- 7-4 **Reserved** ..... always reads 0
- 3 **Map RTC Rx32 to Rx3F**
  - 0 Disable..... default
  - 1 Enable
- 2 **RTC Reset Enable (do not program)**
  - 0 Disable..... default
  - 1 Enable
- 1 **RTC SRAM Access Enable**
  - 0 Disable..... default
  - 1 Enable

This bit is set if the internal RTC is disabled but it is desired to still be able to access the internal RTC SRAM via ports 74-75. If the internal RTC is enabled, setting this bit does nothing (the internal RTC SRAM should be accessed at either ports 70/71 or 72/73.
- 0 **RTC Test Mode Enable (do not program)** .default=0

**Offset 5C - DMA Control..... RW**

- 7 **PCS0# & PCS1# 16-Bit I/O (CF/CG Silicon)**
  - 0 Disable..... default
  - 1 Enable
- 6 **Passive Release**
  - 0 Disable..... default
  - 1 Enable
- 5 **Internal Passive Release**
  - 0 Disable..... default
  - 1 Enable
- 4 **Dummy PREQ**
  - 0 Disable..... default
  - 1 Enable
- 3 **Reserved** ..... always reads 0
- 2 **APIC Connection**
  - 0 APIC on SD Bus..... default
  - 1 APIC on XD Bus
- 1 **Reserved (Do Not Program)** ..... default = 0
- 0 **DMA Line Buffer Disable**
  - 0 DMA cycles can be to/from line buffer ..... def
  - 1 Disable DMA Line Buffer

**Distributed DMA / Serial IRQ Control**

**Offset 61-60 - Distributed DMA Ch 0 Base / Enable.....RW**

- 15-4 Channel 0 Base Address Bits 15-4 ..... default = 0
- 3 Channel 0 Enable
  - 0 Disable .....default
  - 1 Enable
- 2-0 Reserved ..... always reads 0

**Offset 63-62 - Distributed DMA Ch 1 Base / Enable.....RW**

- 15-4 Channel 1 Base Address Bits 15-4 ..... default = 0
- 3 Channel 1 Enable
  - 0 Disable .....default
  - 1 Enable
- 2-0 Reserved ..... always reads 0

**Offset 65-64 - Distributed DMA Ch 2 Base / Enable.....RW**

- 15-4 Channel 2 Base Address Bits 15-4 ..... default = 0
- 3 Channel 2 Enable
  - 0 Disable .....default
  - 1 Enable
- 2-0 Reserved ..... always reads 0

**Offset 67-66 - Distributed DMA Ch 3 Base / Enable.....RW**

- 15-4 Channel 3 Base Address Bits 15-4 ..... default = 0
- 3 Channel 3 Enable
  - 0 Disable .....default
  - 1 Enable
- 2-0 Reserved ..... always reads 0

**Offset 69-68 – Serial IRQ Control .....RW**

- 15-4 Reserved ..... always reads 0
- 3 ISA IRQ Asserted Via Serial IRQ (Pin H3 or L4)
  - 0 Disable .....default
  - 1 Enable
- 2 Serial IRQ Mode
  - 0 Continuous Mode .....default
  - 1 Quiet Mode
- 1-0 Serial IRQ Start-Frame Width
  - 00 4 PCI Clocks .....default
  - 01 6 PCI Clocks
  - 10 8 PCI Clocks
  - 11 10 PCI Clocks

The frame size is fixed at 21 PCI clocks.

**Offset 6B-6A - Distributed DMA Ch 5 Base / Enable.... RW**

- 15-4 Channel 5 Base Address Bits 15-4..... default = 0
- 3 Channel 5 Enable
  - 0 Disable..... default
  - 1 Enable
- 2-0 Reserved ..... always reads 0

**Offset 6D-6C - Distributed DMA Ch 6 Base / Enable ... RW**

- 15-4 Channel 6 Base Address Bits 15-4..... default = 0
- 3 Channel 6 Enable
  - 0 Disable..... default
  - 1 Enable
- 2-0 Reserved ..... always reads 0

**Offset 6F-6E - Distributed DMA Ch 7 Base / Enable .... RW**

- 15-4 Channel 7 Base Address Bits 15-4..... default = 0
- 3 Channel 7 Enable
  - 0 Disable..... default
  - 1 Enable
- 2-0 Reserved ..... always reads 0

**Miscellaneous / General Purpose I/O**

**Offset 73-70 - Subsystem ID ..... WO**

**31-0 Subsystem ID / Vendor ID**..... always reads 0  
Contents may be read at offset 2C.

**Offset 74 – GPIO Control 1.....RW**

- 7 External APIC Enable**  
(U10=APICREQ#, V9=APICACK#, W9=APICCS#)  
CD/DE Silicon:
  - 0 Disable (Pin U5 is SOE# / GPO13) .....default
  - 1 Enable (Pin U5 is SCIOUT#)CF/CG Silicon:
  - 0 Disable (Pin U8 is GPIOD / MCCS#)....default
  - 1 Enable (Pin U8 is SCIOUT#)
 V9 = SUSA# if this bit=0, Rx77[4]=0, F4 Rx54[2]=0  
 W9 = SUSB# if this bit=1, Rx77[4]=0, F4 Rx54[3]=0
- 6 SERIRQ Pin**
  - 0 SERIRQ input from DRQ2 (Pin H3).....default
  - 1 SERIRQ input from DACK5# (Pin L4)
- 5 GPIOD Direction (Pin U8)**
  - 0 Input .....default
  - 1 Output (GPO11)
- 4 GPIOC Direction (Pin V14)**
  - 0 Input .....default
  - 1 Output
- 3 GPIOB Direction (Pin U12)**
  - 0 Input .....default
  - 1 Output
- 2 GPIOA Direction (Pin T14)**
  - 0 Input .....default
  - 1 Output
- 1 THRM Enable (Pin T11)**
  - 0 PME# / GPI5 (see Func 4 Rx48[5]) .....default
  - 1 THRM
- 0 GPIO / IOCHCK# Select**
  - 0 GPIO .....default
  - 1 IOCHCK#

**Offset 75 – GPIO Control 2..... RW**

- 7 GPO7 Enable (Pin T7)**
  - 0 Pin defined as SLP#..... default
  - 1 Pin defined as GPO7
- 6 Reserved** .....always reads 0
- 5 GPO5 Enable (Pin V12)**
  - 0 Pin defined as PCISTP# ..... default
  - 1 Pin defined as GPO5
- 4 GPO4 Enable (Pin Y12)**
  - 0 Pin defined as CPUSTP#..... default
  - 1 Pin defined as GPO4
- 3 FDC External IRQ / DRQ Via DACK2# / DRQ2**
  - 0 Pin G5 is FDCIRQ, pin H3 is FDCDRQ ..... def
  - 1 Pin G5 is DACK2# or other alternate function  
Pin H3 is DRQ2 or other alternate function
- 2 GPO25 Enable (Pin G5)**
  - 0 Rx75[3]=0: Pin G5 defined as DACK2# .... def
  - 1 Pin G5 defined as GPO25
- 1 GPO24 Enable (Pin H3)**
  - 0 Rx75[3]=0: ..... default  
Rx68[3]=0: Pin H3 defined as DRQ2  
Rx68[3]=1: Pin H3 defined as SERIRQ
  - 1 Pin H3 defined as GPO24
- 0 Positive Decode**
  - 0 Subtractive Decode..... default
  - 1 Positive Decode



**Offset 76 – GPIO Control 3 (00) .....RW**

- 7 Over-Current (OC) Input**
  - 0 Disable .....default
  - 1 Enable
- 6 OC[3:0] From SD[3:0] By Scan**
  - 0 Disable .....default
  - 1 Enable
- 5 GPO14 / GPO15 Enable (Pins E12 / D12)**
  - 0 Pins used for IRTX and IRRX .....default
  - 1 Pins used for GPO14 and GPO15
- 4 PCS0# Function (CD/CE Silicon)**
  - 0 Disable .....default
  - 1 Enable
- 4 MCCS# Pin Select (CF/CG Silicon)**
  - 0 MCCS# is on Pin U5 .....default
  - 1 MCCS# is on Pin U8
- 3 MCCS# Function**
  - CD/CE Silicon:
    - 0 Pin U8 defined as GPIOD .....default
    - 1 Pin U8 defined as MCCS#
  - CF/CG Silicon:
    - 0 Disable MCCS# function on U5/U8.....default
    - 1 Enable MCCS# function on U5/U8  
(see bit-4 for select of U5 or U8 for MCCS#)
- 2 CHAS Enable (Pin V14)**
  - 0 Pin is defined as GPIOC.....default
  - 1 Pin is defined as CHAS
- 1 GPO12 Enable (Pin T5)**
  - 0 Pin is defined as XDIR.....default
  - 1 Pin is defined as GPO12
- 0 GPOWE# (GPO[23-16]) Enable (Pin T14)**
  - 0 Pin is defined as GPIOA .....default
  - 1 Pin is defined as GPOWE# (Rx74[2] also must be set to 1)

**Offset 77 – GPIO Control 4 Control (10h) ..... RW**

- 7 DRQ / DACK# Pins are GPI / GPO**
  - 0 Disable..... default
  - 1 Enable
- 6 Game Port XY Pins are GPI / GPO**
  - 0 Disable..... default
  - 1 Enable
- 5 Reserved** .....always reads 0
- 4 Internal APIC Enable (CG)**
  - 0 Disable
  - 1 Enable (U10 = WSC#, V9 = APICD0, T10 = APICD1)..... default
- 3 SERIRQ SMI Slot**
  - 0 Disable..... default
  - 1 Enable
- 2 RTC Rx32 Write Protect**
  - 0 Disable..... default
  - 1 Enable
- 1 RTC Rx0D Write Protect**
  - 0 Disable..... default
  - 1 Enable
- 0 GPO13 Enable (Pin U5)**
  - 0 Pin defined as SOE# ..... default
  - 1 Pin defined as GPO13

**Offset 79-78 – PCS0# I/O Port Address (CF/CG) .....RW**

**15-0** PCS0# I/O Port Address [15-0]

**Offset 7B-7A – PCS1# I/O Port Address (CF/CG).....RW**

**15-0** PCS1# I/O Port Address [15-0]

**Offset 7D-7C – PCI DMA Channel Enable (CF/CG).....RW**

**15-9** Reserved ..... always reads 0

**8 PCI DMA Pair A**

0 Disable .....default  
1 Enable

**7 PCI DMA Channel 7**

0 Disable .....default  
1 Enable

**6 PCI DMA Channel 6**

0 Disable .....default  
1 Enable

**5 PCI DMA Channel 5**

0 Disable .....default  
1 Enable

**4** Reserved ..... always reads 0

**3 PCI DMA Channel 3**

0 Disable .....default  
1 Enable

**2 PCI DMA Channel 2**

0 Disable .....default  
1 Enable

**1 PCI DMA Channel 1**

0 Disable .....default  
1 Enable

**0 PCI DMA Channel 0**

0 Disable .....default  
1 Enable

**Offset 7F-7E – 32-Bit DMA Control (CF/CG)..... RW**

**15-3** 32-Bit DMA High Page (A31-24) Registers IOBase

**2-1** Reserved .....always reads 0

**0** 32-Bit DMA

0 Disable..... default  
1 Enable

**Offset 80 – Programmable Chip Select Mask (CF/CG). RW**

**7-4** PCS1# I/O Port Address Mask [3-0]

**3-0** PCS0# I/O Port Address Mask [3-0]

**Offset 81 – ISA Positive Decoding Control 1 .....RW**

- 7 On-Board I/O Port Positive Decoding**
  - 0 Disable .....default
  - 1 Enable
- 6 Microsoft-Sound System I/O Port Positive Decoding**
  - 0 Disable .....default
  - 1 Enable
- 5-4 Microsoft-Sound System I/O Decode Range**
  - 00 0530h-0537h .....default
  - 01 0604h-060Bh
  - 10 0E80-0E87h
  - 11 0F40h-0F47h
- 3 APIC Positive Decoding**
  - 0 Disable .....default
  - 1 Enable
- 2 BIOS ROM Positive Decoding**
  - 0 Disable .....default
  - 1 Enable
- 1 Reserved** ..... always reads 0
- 0 PCS0 Positive Decoding**
  - 0 Disable .....default
  - 1 Enable

**Offset 82 – ISA Positive Decoding Control 2 .....RW**

- 7 FDC Positive Decoding**
  - 0 Disable .....default
  - 1 Enable
- 6 LPT Positive Decoding**
  - 0 Disable .....default
  - 1 Enable
- 5-4 LPT Decode Range**
  - 00 3BCh-3BFh, 7BCh-7BEh.....default
  - 01 378h-37Fh, 778h-77Ah
  - 10 278h-27Fh, 678h-67Ah
  - 11 -reserved-
- 3 Game Port Positive Decoding**
  - 0 Disable .....default
  - 1 Enable
- 2 MIDI Positive Decoding**
  - 0 Disable .....default
  - 1 Enable
- 1-0 MIDI Decode Range**
  - 00 300h-303h .....default
  - 01 310h-313h
  - 10 320h-323h
  - 11 330h-333h

**Offset 83 – ISA Positive Decoding Control 3..... RW**

- 7 COM Port B Positive Decoding**
  - 0 Disable..... default
  - 1 Enable
- 6-4 COM-Port B Decode Range**
  - 000 3F8h-3FFh (COM1)..... default
  - 001 2F8h-2FFh (COM2)
  - 010 220h-227h
  - 011 228h-22Fh
  - 100 238h-23Fh
  - 101 2E8h-2EFh (COM4)
  - 110 338h-33Fh
  - 111 3E8h-3EFh (COM3)
- 3 COM Port A Positive Decoding**
  - 0 Disable..... default
  - 1 Enable
- 2-0 COM-Port A Decode Range**
  - 000 3F8h-3FFh (COM1)..... default
  - 001 2F8h-2FFh (COM2)
  - 010 220h-227h
  - 011 228h-22Fh
  - 100 238h-23Fh
  - 101 2E8h-2EFh (COM4)
  - 110 338h-33Fh
  - 111 3E8h-3EFh (COM3)

**Offset 84 – ISA Positive Decoding Control 4..... RW**

- 7-4 Reserved** ..... always reads 0
- 3 FDC Decoding Range**
  - 0 Primary ..... default
  - 1 Secondary
- 2 Sound Blaster Positive Decoding**
  - 0 Disable..... default
  - 1 Enable
- 1-0 Sound Blaster Decode Range**
  - 00 220h-22Fh, 230h-233h ..... default
  - 01 240h-24Fh, 250h-253h
  - 10 260h-26Fh, 270h-273h
  - 11 280h-28Fh, 290h-293h

**Offset 85 – Extended Function Enable .....RW**

- 7-5 **Reserved** ..... always reads 0
- 4 **Function 3 USB Ports 2-3**
  - 0 Enable.....default
  - 1 Disable
- 3 **Function 6 Modem / Audio**
  - 0 Enable.....default
  - 1 Disable
- 2 **Function 5 Audio**
  - 0 Enable.....default
  - 1 Disable
- 1 **Super-I/O Configuration**
  - 0 Disable .....default
  - 1 Enable
- 0 **Super-I/O**
  - 0 Disable .....default
  - 1 Enable

**Offset 86 – PNP IRO/DRO Test 1 (Do Not Program) ... RW**

**Offset 87 – PNP IRO/DRO Test 2 (Do Not Program) ... RW**

**Offset 88 – PLL Test .....RW**

- 7 PCS0# Access Status (CF/CG Silicon)
- 6 RTC Rx32 / Rx7F Write Protect (CF/CG)
  - 0 Disable .....default
  - 1 Enable
- 5 MC IRQ Test (Do Not Program)
  - 0 Disable .....default
  - 1 Enable
- 4 PLL PU (Do Not Program)
  - 0 Disable .....default
  - 1 Enable
- 3 PLL Test Mode (Do Not Program)
  - 0 Disable .....default
  - 1 Enable
- 2-0 PLL Test Mode Select

**Offset 89 – PLL Control .....RW**

- 7-4 Reserved ..... always reads 0
- 3-2 PLL PCLK Input Delay Select
- 1-0 PLL CLK66 Feedback Delay Select

**Offset 8A – PCS2/3 I/O Port Address Mask (CF/CG)... RW**

- 7-4 PCS3# I/O Port Address Mask 3-0
- 3-0 PCS2# I/O Port Address Mask 3-0

**Offset 8B – PCS Control (CF/CG Silicon)..... RW**

- 7 PCS3# For Internal I/O
  - 0 Disable..... default
  - 1 Enable
- 6 PCS2# For Internal I/O
  - 0 Disable..... default
  - 1 Enable
- 5 PCS1# For Internal I/O
  - 0 Disable..... default
  - 1 Enable
- 4 PCS0# For Internal I/O
  - 0 Disable..... default
  - 1 Enable
- 3 PCS3#
  - 0 Disable..... default
  - 1 Enable
- 2 PCS2#
  - 0 Disable..... default
  - 1 Enable
- 1 PCS1#
  - 0 Disable..... default
  - 1 Enable
- 0 PCS0#
  - 0 Disable..... default
  - 1 Enable

**Offset 8D-8C – PCS2# I/O Port Address (CF/CG)..... RW**

- 15-0 PCS2# I/O Port Address

**Offset 8F-8E – PCS3# I/O Port Address (CF/CG)..... RW**

- 15-0 PCS3# I/O Port Address

**Function 1 Registers - Enhanced IDE Controller**

This Enhanced IDE controller interface is fully compatible with the SFF 8038i v.1.0 specification. There are two sets of software accessible registers -- PCI configuration registers and Bus Master IDE I/O registers. The PCI configuration registers are located in the function 1 PCI configuration space of the VT82C686A. The Bus Master IDE I/O registers are defined in the SFF8038i v1.0 specification.

**PCI Configuration Space Header**

**Offset 1-0 - Vendor ID (1106h=VIA).....RO**

**Offset 3-2 - Device ID (0571h=IDE Controller).....RO**

**Offset 5-4 - Command.....RW**

- 15-10 **Reserved** ..... always reads 0
- 9 **Fast Back to Back Cycles** ..... default = 0 (disabled)
- 8 **SERR# Enable**..... default = 0 (disabled)
- 7 **Address Stepping** ..... **fixed at 1 (enabled)**  
A value of 1 provides additional address decode time to IDE devices.
- 6 **Parity Error Response**..... default = 0 (disabled)
- 5 **VGA Palette Snoop** .....fixed at 0 (disabled)
- 4 **Memory Write & Invalidate** .....fixed at 0 (disabled)
- 3 **Special Cycles** .....fixed at 0 (disabled)
- 2 **Bus Master** ..... default = 0 (disabled)  
S/G operation can be issued only when the “Bus Master” bit is enabled.
- 1 **Memory Space**.....fixed at 0 (disabled)
- 0 **I/O Space** ..... default = 0 (disabled)  
When the “I/O Space” bit is disabled, the device will not respond to any I/O addresses for both compatible and native mode.

**Offset 7-6 - Status.....RWC (CD/CE) / RO (CF/CG)**

- 15 **Detected Parity Error** .....CD/CE: default=0  
..... CF/CG: fixed at 0
- 14 **Signalled System Error** .....CD/CE: default=0  
..... CF/CG: fixed at 0
- 13 **Received Master Abort**.....CD/CE: default=0  
..... CF/CG: fixed at 0
- 12 **Received Target Abort** .....CD/CE: default=0  
..... CF/CG: fixed at 0
- 11 **Signalled Target Abort**.....Fixed at 0
- 10-9 **DEVSEL# Timing** ..... default = 01 (medium)
- 8 **Data Parity Detected**.....CD/CE: default=0  
..... CF/CG: fixed at 0
- 7 **Fast Back to Back** .....Fixed at 1
- 6-0 **Reserved** ..... always reads 0

**Offset 8 - Revision ID (06).....RO**

- 0-7 **Revision Code for IDE Controller Logic Block**

**Offset 9 - Programming Interface..... RW**

- 7 **Master IDE Capability**..... fixed at 1 (Supported)
- 6-4 **Reserved** .....always reads 0
- 3 **Programmable Indicator - Secondary** ..... fixed at 1  
Supports both modes (may be set to either mode by writing bit-2)
- 2 **Reserved (CF/CG)**.....always reads 0
- 2 **Channel Operating Mode – Secondary (CD/CE)**  
0 Compatibility Mode (fixed addressing)  
1 Native PCI Mode (flexible addressing) ..... def
- 1 **Programmable Indicator - Primary** ..... fixed at 1  
Supports both modes (may be set to either mode by writing bit-0)
- 0 **Reserved (CF/CG)**.....always reads 0
- 0 **Channel Operating Mode – Primary (CD/CE)**  
0 Compatibility Mode (fixed addressing)  
1 Native PCI Mode (flexible addressing) ..... def

**Compatibility Mode (fixed IRQs and I/O addresses):**

	Command Block	Control Block	
Channel	Registers	Registers	IRQ
Pri	1F0-1F7	3F6	14
Sec	170-177	376	15

**Native PCI Mode (registers are programmable in I/O space)**

	Command Block	Control Block
Channel	Registers	Registers
Pri	BA @offset 10h	BA @offset 14h
Sec	BA @offset 18h	BA @offset 1Ch

Command register blocks are 8 bytes of I/O space  
Control registers are 4 bytes of I/O space (only byte 2 is used)

**Offset A - Sub Class Code (01h=IDE Controller)..... RO**

**Offset B - Base Class Code (01h=Mass Storage Ctrlr)... RO**

**Offset C – Cache Line Size (00h)..... RO**

**Offset D - Latency Timer (Default=0)..... RW**

**Offset E - Header Type (00h)..... RO**

**Offset F - BIST (00h)..... RO**

**Offset 13-10 - Pri Data / Command Base Address.....RW**

Specifies an 8 byte I/O address space.

- 31-16 Reserved .....always read 0
- 15-3 Port Address ..... default=01F0h
- 2-0 Fixed at 001b ..... fixed

**Offset 17-14 - Pri Control / Status Base Address.....RW**

Specifies a 4 byte I/O address space of which only the third byte is active (i.e., 3F6h for the default base address of 3F4h).

- 31-16 Reserved .....always read 0
- 15-2 Port Address ..... default=03F4h
- 1-0 Fixed at 01b ..... fixed

**Offset 1B-18 - Sec Data / Command Base Address .....RW**

Specifies an 8 byte I/O address space.

- 31-16 Reserved .....always read 0
- 15-3 Port Address ..... default=0170h
- 2-0 Fixed at 001b ..... fixed

**Offset 1F-1C - Sec Control / Status Base Address.....RW**

Specifies a 4 byte I/O address space of which only the third byte is active (i.e., 376h for the default base address of 374h).

- 31-16 Reserved .....always read 0
- 15-2 Port Address ..... default=0374h
- 1-0 Fixed at 01b ..... fixed

**Offset 23-20 - Bus Master Control Regs Base Address..RW**

Specifies a 16 byte I/O address space compliant with the SFF-8038i rev 1.0 specification.

- 31-16 Reserved .....always read 0
- 15-4 Port Address ..... default=CC0h
- 3-0 Fixed at 0001b ..... fixed

**Offset 34 - Capability Pointer (CF/CG) (C0h) ..... RO**

**Offset 3C - Interrupt Line (0Eh)RW (CD/CE), RO (CF/CG)**

**Offset 3D - Interrupt Pin (00h)..... RO**

**7-0 Interrupt Routing Mode**

- 00h Legacy mode interrupt routing..... default
- 01h Native mode interrupt routing

**Offset 3E - Min Gnt (00h) ..... RO**

**Offset 3F - Max Latency (00h)..... RO**



**IDE-Controller-Specific Configuration Registers**

**Offset 40 - Chip Enable (00h).....RW**

- 7-4 **Reserved** ..... always reads 0
- 3-2 **Reserved (Do Not Program)**..... R/W, default = 0
- 1 **Primary Channel Enable**..... default = 0 (disabled)
- 0 **Secondary Channel Enable** .... default = 0 (disabled)

**Offset 41 - IDE Configuration (06h).....RW**

- 7 **Primary IDE Read Prefetch Buffer**
  - 0 Disable .....default
  - 1 Enable
- 6 **Primary IDE Post Write Buffer**
  - 0 Disable .....default
  - 1 Enable
- 5 **Secondary IDE Read Prefetch Buffer**
  - 0 Disable .....default
  - 1 Enable
- 4 **Secondary IDE Post Write Buffer**
  - 0 Disable .....default
  - 1 Enable
- 3 **Reserved (CF/CG)**..... always reads 0
- 3 **SERR# Response (CD/CE)**
  - 0 Disable .....default
  - 1 Enable
- 2 **Reserved (Do Not Change)**..... default=1
- 1 **Reserved (Do Not Change)**..... default=1
- 0 **Reserved (CF/CG)**..... always reads 0
- 0 **PERR# Response (CD/CE)**
  - 0 Disable .....default
  - 1 Enable

**Offset 42 - Reserved (Do Not Program) (09h) .....RW**

**Offset 43 - FIFO Configuration (0Ah)..... RW**

- 7-4 **Reserved** ..... always reads 0
- 3-2 **Threshold for Primary Channel**
  - 00 0
  - 01 1/4
  - 10 1/2 ..... default
  - 11 3/4
- 1-0 **Threshold for Secondary Channel**
  - 00 0
  - 01 1/4
  - 10 1/2 ..... default
  - 11 3/4

**Offset 44 - Miscellaneous Control 1 (68h).....RW**

- 7 **Reserved** ..... always reads 0
- 6 **Master Read Cycle IRDY# Wait States**
  - 0 0 wait states
  - 1 1 wait state.....default
- 5 **Master Write Cycle IRDY# Wait States**
  - 0 0 wait states
  - 1 1 wait state.....default
- 4 **Reserved** ..... always reads 0
- 3 **Bus Master IDE Status Register Read Retry**  
Retry bus master IDE status register read when master write operation for DMA read is not complete
  - 0 Disable
  - 1 Enable.....default
- 2-1 **Reserved** ..... always reads 0
- 0 **UltraDMA Host Must Wait for First Strobe Before Termination**
  - 0 Enable.....default
  - 1 Disable

**Offset 45 - Miscellaneous Control 2 (00h).....RW**

- 7 **Reserved** ..... always reads 0
- 6 **Interrupt Steering Swap**
  - 0 Don't swap channel interrupts .....default
  - 1 Swap interrupts between the two channels
- 5-4 **Reserved** ..... always reads 0
- 3 **Memory Read Multiple Command**
  - 0 Disable .....default
  - 1 Enable
- 2 **Memory Read and Invalidate Command**
  - 0 Disable .....default
  - 1 Enable
- 1 **Secondary Channel Threshold Enable**
  - 0 Disable (data transfer will not start until the FIFO is filled to the threshold set in bits 1-0 of Rx43) .....default
  - 1 Enable (data transfer starts immediately if FIFO is not empty)
- 0 **Primary Channel Threshold Enable**
  - 0 Disable (data transfer will not start until the FIFO is filled to the threshold set in bits 3-2 of Rx43) .....default
  - 1 Enable (data transfer starts immediately if FIFO is not empty)

**Offset 46 - Miscellaneous Control 3 (C0h) ..... RW**

- 7 **Primary Channel Read DMA FIFO Flush**
  - 0 Disable
  - 1 Enable FIFO flush for Read DMA when interrupt asserts primary channel. .... default
- 6 **Secondary Channel Read DMA FIFO Flush**
  - 0 Disable
  - 1 Enable FIFO flush for Read DMA when interrupt asserts secondary channel..... default
- 5 **Primary Channel End-of-Sector FIFO Flush**
  - 0 Disable..... default
  - 1 Enable FIFO flush at the end of each sector for the primary channel
- 4 **Secondary Channel End-of-Sector FIFO Flush**
  - 0 Disable..... default
  - 1 Enable FIFO flush at the end of each sector for the secondary channel.
- 3-2 **Reserved** .....always reads 0
- 1-0 **Max DRDY Pulse Width**  
Maximum DRDY# pulse width after the cycle count. Command will deassert in spite of DRDY# status to avoid system ready hang.
  - 00 No limitation..... default
  - 01 64 PCI clocks
  - 10 128 PCI clocks
  - 11 192 PCI clocks

**Offset 4B-48 - Drive Timing Control (A8A8A8A8h).....RW**

The following fields define the Active Pulse Width and Recovery Time for the IDE DIOR# and DIOW# signals:

- 31-28 Primary Drive 0 Active Pulse Width..... def=1010b
- 27-24 Primary Drive 0 Recovery Time..... def=1000b
- 23-20 Primary Drive 1 Active Pulse Width..... def=1010b
- 19-16 Primary Drive 1 Recovery Time..... def=1000b
- 15-12 Secondary Drive 0 Active Pulse Width .. def=1010b
- 11-8 Secondary Drive 0 Recovery Time ..... def=1000b
- 7-4 Secondary Drive 1 Active Pulse Width .. def=1010b
- 3-0 Secondary Drive 1 Recovery Time ..... def=1000b

The actual value for each field is the encoded value in the field plus one and indicates the number of PCI clocks.

**Offset 4C - Address Setup Time (FFh).....RW**

- 7-6 Primary Drive 0 Address Setup Time ..... def = 11
- 5-4 Primary Drive 1 Address Setup Time ..... def = 11
- 3-2 Secondary Drive 0 Address Setup Time .... def = 11
- 1-0 Secondary Drive 1 Address Setup Time .... def = 11

For each field above:

- 00 1T
- 01 2T
- 10 3T
- 11 4T .....default

**Offset 4E - Sec Non-1F0 Port Access Timing (FFh).....RW**

- 7-4 DIOR#/DIOW# Active Pulse Width..... def=1111b
- 3-0 DIOR#/DIOW# Recovery Time..... def=1111b

The actual value for each field is the encoded value in the field plus one and indicates the number of PCI clocks.

**Offset 4F - Pri Non-1F0 Port Access Timing (FFh).....RW**

- 7-4 DIOR#/DIOW# Active Pulse Width..... def=1111b
- 3-0 DIOR#/DIOW# Recovery Time..... def=1111b

The actual value for each field is the encoded value in the field plus one and indicates the number of PCI clocks.

**Offset 53-50 - UltraDMA Extended Timing Control..... RW**

- 31 Pri Drive 0 UltraDMA-Mode Enable Method
  - 0 Enable by using "Set Feature" command..... def
  - 1 Enable by setting bit-30 of this register
- 30 Pri Drive 0 UltraDMA-Mode Enable
  - 0 Disable..... default
  - 1 Enable UltraDMA-Mode Operation
- 29 Pri Drive 0 Transfer Mode
  - 0 DMA or PIO Mode ..... default
  - 1 UltraDMA Mode
- 28-27 Reserved .....always reads 0
- 26-24 Pri Drive 0 Cycle Time (T = 30nsec @33MHz)
  - 000 2T
  - 001 3T
  - 010 4T
  - 011 5T ..... default (version CD/CE)
  - 100 6T
  - 101 7T
  - 110 8T
  - 111 9T ..... default (CF/CG)
- 23 Pri Drive 1 UltraDMA-Mode Enable Method
- 22 Pri Drive 1 UltraDMA-Mode Enable
- 21 Pri Drive 1 Transfer Mode
- 20 Reserved .....always reads 0
- 19 Pri Clock Source
  - 0 33 MHz..... default
  - 1 66 MHz
- 18-16 Pri Drive 1 Cycle Time..... (see above for default)
  - 15 Sec Drive 0 UltraDMA-Mode Enable Method
  - 14 Sec Drive 0 UltraDMA-Mode Enable
  - 13 Sec Drive 0 Transfer Mode
  - 12-11 Reserved .....always reads 0
  - 10-8 Sec Drive 0 Cycle Time ..... (see above for default)
    - 7 Sec Drive 1 UltraDMA-Mode Enable Method
    - 6 Sec Drive 1 UltraDMA-Mode Enable
    - 5 Sec Drive 1 Transfer Mode
    - 4 Reserved .....always reads 0
    - 3 Sec Clock Source
      - 0 33 MHz..... default
      - 1 66 MHz
    - 2-0 Sec Drive 1 Cycle Time ..... (see above for default)

Each byte defines UltraDMA operation for the indicated drive. The bit definitions are the same within each byte.

**Offset 54 – UltraDMA FIFO Control (06h).....RW**

- 7-6 **Reserved** ..... always reads 0
- 5 **CD/CE Silicon: De-Assert PREQ# For PCI Master Cache Line Boundary**
  - 0 Disable .....default
  - 1 Enable
- CF Silicon: Reserved**..... always reads 0
- CG Silicon Rev B: PCI Read Word Alignment FIFO Dummy Push**
  - 0 Disable .....default
  - 1 Enable
- 4 **One Frame For Each PCI Request For IDE PCI Master Cycles**
  - 0 Disable .....default
  - 1 Enable
- 3 **Grant ISA While Sharing Bus with SA & IDE in IDLE State**
  - 0 Enable.....default
  - 1 Disable
- 2 **Change Drive to Clear All FIFO & Internal States**
  - 0 Disable
  - 1 Enable.....default
- 1 **Add Dummy FIFO Push After End of Transfer**
  - 0 Enable
  - 1 Disable .....default

This bit is normally set to 0 for effective handling of transfer lengths that are not doubleword multiples
- 0 **Complete DMA Cycle with Transfer Size Less Than FIFO Size**
  - 0 Enable.....default
  - 1 Disable

**Offset 61-60 - Primary Sector Size (0200h) ..... RW**

- 15-12 **Reserved** ..... always reads 0
- 11-0 **Number of Bytes Per Sector** ...def=200h (512 bytes)

**Offset 69-68 - Secondary Sector Size (0200h)..... RW**

- 15-12 **Reserved** ..... always reads 0
- 11-0 **Number of Bytes Per Sector** ...def=200h (512 bytes)

**Offset 70 – Primary IDE Status .....RW**

- 7 Interrupt Status
- 6 Prefetch Buffer Status
- 5 Post Write Buffer Status
- 4 DMA Read Prefetch Status
- 3 DMA Write Prefetch Status
- 2 S/G Operation Complete
- 1-0 Reserved ..... always reads 0

**Offset 71 – Primary Interrupt Control (CF/CG).....RW**

- 7-1 Reserved ..... always reads 0
- 0 Flush FIFO Before Generating IDE Interrupt
  - 0 Disable .....default
  - 1 Enable

**Offset 74 – Primary IDE Command 1 (CD/CE) .....RW**

- 7 Reload Sector Size After Last Command Register Write
- 6-0 Reserved ..... always reads 0

**Offset 75 – Primary IDE Command 2 (CD/CE) .....RW**

- 7 Set Controller to Perform PIO Mode Data Port Prefetch
- 6 Set Controller to Perform PIO Mode Data Port Buffer Write
- 5 Set Controller to Perform DMA Mode Read Pipeline Operation
- 4 Set Controller to Perform DMA Mode Write Pipeline Operation
- 3 Stop S/G Bus Master
- 2-0 Reserved ..... always reads 0

**Offset 78 – Secondary IDE Status ..... RW**

- 7 Interrupt Status
- 6 Prefetch Buffer Status
- 5 Post Write Buffer Status
- 4 DMA Read Prefetch Status
- 3 DMA Write Prefetch Status
- 2 S/G Operation Complete
- 1-0 Reserved ..... always reads 0

**Offset 79 - Secondary Interrupt Control (CF/CG) ..... RW**

- 7-1 Reserved ..... always reads 0
- 0 Flush FIFO Before Generating IDE Interrupt
  - 0 Disable ..... default
  - 1 Enable

**Offset 7C – Secondary IDE Command 1 (CD/CE) ..... RW**

- 7 Reload Sector Size After Last Command Register Write
- 6-0 Reserved ..... always reads 0

**Offset 7D – Secondary IDE Command 2 (CD/CE) ..... RW**

- 7 Set Controller to Perform PIO Mode Data Port Prefetch
- 6 Set Controller to Perform PIO Mode Data Port Buffer Write
- 5 Set Controller to Perform DMA Mode Read Pipeline Operation
- 4 Set Controller to Perform DMA Mode Write Pipeline Operation
- 3 Stop S/G Bus Master
- 2-0 Reserved ..... always reads 0

**Offset 83-80 – Primary S/G Descriptor Address .....RW**

**Offset 8B-88 – Secondary S/G Descriptor Address .....RW**

**Offset C3-C0 – PCI PM Block 1 (CF/CG) .....RO**

**31-0 PCI PM Block 1..... always reads 0201h**

**Offset C7-C4 – PCI PM Block 2 (CF/CG) .....RO**

**31-2 Reserved ..... always reads 0**

**1-0 Power State**

00 On .....default

01 Off

1x -reserved-

**IDE I/O Registers**

These registers are compliant with the SFF 8038I v1.0 standard. Refer to the SFF 8038I v1.0 specification for further details.

**I/O Offset 0 - Primary Channel Command**

**I/O Offset 2 - Primary Channel Status**

**I/O Offset 4-7 - Primary Channel PRD Table Address**

**I/O Offset 8 - Secondary Channel Command**

**I/O Offset A - Secondary Channel Status**

**I/O Offset C-F - Secondary Channel PRD Table Address**

**Function 2 Registers - USB Controller Ports 0-1**

This Universal Serial Bus host controller interface is fully compatible with UHCI specification v1.1. There are two sets of software accessible registers: PCI configuration registers and USB I/O registers. The PCI configuration registers are located in the function 2 PCI configuration space of the VT82C686A. The USB I/O registers are defined in UHCI specification v1.1. The registers in this function control USB ports 0-1 (see function 3 for ports 2-3).

**PCI Configuration Space Header**

**Offset 1-0 - Vendor ID .....RO**

0-7 Vendor ID ..... (1106h = VIA Technologies)

**Offset 3-2 - Device ID.....RO**

0-7 Device ID (3038h = VT82C686A USB Controller)

**Offset 5-4 - Command.....RW**

- 15-8 Reserved ..... always reads 0
- 7 Address Stepping ..... default=0 (disabled)
- 6 Reserved (parity error response) .....fixed at 0
- 5 Reserved (VGA palette snoop) .....fixed at 0
- 4 Memory Write and Invalidate . default=0 (disabled)
- 3 Reserved (special cycle monitoring) .....fixed at 0
- 2 Bus Master ..... default=0 (disabled)
- 1 Memory Space..... default=0 (disabled)
- 0 I/O Space ..... default=0 (disabled)

**Offset 7-6 - Status.....RWC**

- 15 Reserved (detected parity error)..... always reads 0
- 14 Signalled System Error..... default=0
- 13 Received Master Abort..... default=0
- 12 Received Target Abort ..... default=0
- 11 Signalled Target Abort..... default=0
- 10-9 DEVSEL# Timing
  - 00 Fast
  - 01 Medium .....default (fixed)
  - 10 Slow
  - 11 Reserved
- 8-0 Reserved ..... always reads 0

**Offset 8 - Revision ID (nnh)..... RO**

- 7-0 Silicon Revision Code (0 indicates first silicon)
- 06h Corresponds to Chip Revision D

**Offset 9 - Programming Interface (00h) ..... RO**

**Offset A - Sub Class Code (03h=USB Controller) ..... RO**

**Offset B - Base Class Code (0Ch=Serial Bus Controller)RO**

**Offset C - Cache Line Size (00h)..... RO**

**Offset D - Latency Timer ..... RW**

- 7-0 Timer Value ..... default = 16h

**Offset E - Header Type (00h)..... RO**

**Offset F - BIST (00h)..... RO**

**Offset 23-20 - USB I/O Register Base Address..... RW**

- 31-16 Reserved ..... always reads 0
- 15-5 USB I/O Register Base Address. Port Address for the base of the 32-byte USB I/O Register block, corresponding to AD[15:5]
- 4-0 00001b

**Offset 3C - Interrupt Line (00h)..... RW**

- 7-4 Reserved ..... always reads 0
- 3-0 USB Interrupt Routing ..... default = 16h
  - 0000 Disable..... default
  - 0001 IRQ1
  - 0010 Reserved
  - 0011 IRQ3
  - 0100 IRQ4
  - 0101 IRQ5
  - 0110 IRQ6
  - 0111 IRQ7
  - 1000 IRQ8
  - 1001 IRQ9
  - 1010 IRQ10
  - 1011 IRQ11
  - 1100 IRQ12
  - 1101 IRQ13
  - 1110 IRQ14
  - 1111 Disable

**Offset 3D - Interrupt Pin (04h)..... RO**



**USB-Specific Configuration Registers**

**Offset 40 - Miscellaneous Control 1.....RW**

- 7 PCI Memory Command Option**
  - 0 Support Memory-Read-Line, Memory-Read-Multiple, & Memory-Write-&-Invalidate.... def
  - 1 Only support Mem Read, Mem Write Cmds
- 6 Babble Option**
  - 0 Automatically disable babbled port when EOF babble occurs.....default
  - 1 Don't disable babbled port
- 5 PCI Parity Check Option**
  - 0 Disable PERR# generation.....default
  - 1 Enable parity check and PERR# generation
- 4 Frame Interval Select**
  - 0 1 ms frame .....default
  - 1 0.1 ms frame
- 3 USB Data Length Option**
  - 0 Support TD length up to 1280.....default
  - 1 Support TD length up to 1023
- 2 USB Power Management**
  - 0 Disable USB power management .....default
  - 1 Enable USB power management
- 1 DMA Option**
  - 0 8 DW burst access with better FIFO latency def
  - 1 16 DW burst access (original performance)
- 0 PCI Wait States**
  - 0 Zero wait .....default
  - 1 One wait

**Offset 41 - Miscellaneous Control 2 ..... RW**

- 7 USB 1.1 Improvement for EOP**
  - 0 USB Specification 1.1 Compliant..... default  
If a bit stuffing error occurs before EOP, the receiver will accept the packet
  - 1 USB Specification 1.0 Compliant  
If a bit stuffing error occurs before EOP, the receiver will ignore the packet
- 6-5 Reserved (Do Not Program) ..... default = 0**
- 4 Hold PCI Request for Successive Accesses**
  - 0 Disable
  - 1 Enable ..... default  
Setting this bit to "enable" causes the system to treat the USB request as higher priority
- 3 Frame Counter Test Mode**
  - 0 Disable ..... default
  - 1 Enable
- 2 Trap Option**
  - 0 Set trap 60/64 status bits only when trap 60/64 enable bits are set. .... default
  - 1 Set trap 60/64 status bits without checking enable bits
- 1 A20gate Pass Through Option**
  - 0 Pass through A20GATE command sequence defined in UHCI ..... default
  - 1 Don't pass through Write I/O port 64 (ff)
- 0 USB IRQ Test Mode**
  - 0 Normal Operation ..... default
  - 1 Generate USB IRQ

**Offset 42 - FIFO Control I (CF/CG).....RW**

- 7-4 **Reserved** ..... always reads 0
- 3-2 **Reserved (Do Not Program)**..... default = 0
- 1-0 **Release Continuous REQ After “N” PCICLKs**
  - 00 Do Not Release .....default
  - 01 N = 32 PCICLKs
  - 10 N = 64 PCICLKs
  - 11 N = 96 PCICLKs

**Offset 43 - FIFO Control II (CG) .....RW**

- 7-3 **Reserved** ..... always reads 0
- 2 **Issue CRS Error on FIFO Underrun**
  - 0 Disable .....default
  - 1 Enable
- 1-0 **Reserved** ..... always reads 0

**Offset 60 - Serial Bus Release Number.....RO**

- 7-0 **Release Number**..... always reads 10h

**Offset 83-80 – PM Capability (CF/CG).....RO**

- 31-0 **PM Capability** ..... always reads 00020001h

**Offset 84 – PM Capability Status (CF/CG).....RW**

- 7-0 **PM Capability Status**..... default = 00h  
Supports 00h (Off) and 11h (On) only

**Offset C1-C0 - Legacy Support.....RO**

- 15-0 **UHCI v1.1 Compliant**..... always reads 2000h

**USB I/O Registers**

These registers are compliant with the UHCI v1.1 standard. Refer to the UHCI v1.1 specification for further details.

**I/O Offset 1-0 - USB Command**

**I/O Offset 3-2 - USB Status**

**I/O Offset 5-4 - USB Interrupt Enable**

**I/O Offset 7-6 - Frame Number**

**I/O Offset B-8 - Frame List Base Address**

**I/O Offset 0C - Start Of Frame Modify**

**I/O Offset 11-10 - Port 0 Status / Control**

**I/O Offset 13-12 - Port 1 Status / Control**

**Function 3 Registers - USB Controller Ports 2-3**

This Universal Serial Bus host controller interface is fully compatible with UHCI specification v1.1. There are two sets of software accessible registers: PCI configuration registers and USB I/O registers. The PCI configuration registers are located in the function 3 PCI configuration space of the VT82C686A. The USB I/O registers are defined in UHCI specification v1.1. The registers in this function control USB ports 2-3 (see function 2 for ports 0-1).

**PCI Configuration Space Header**

**Offset 1-0 - Vendor ID .....RO**

0-7 Vendor ID ..... (1106h = VIA Technologies)

**Offset 3-2 - Device ID.....RO**

0-7 Device ID (3038h = VT82C686A USB Controller)

**Offset 5-4 - Command.....RW**

- 15-8 Reserved ..... always reads 0
- 7 Address Stepping ..... default=0 (disabled)
- 6 Reserved (parity error response) .....fixed at 0
- 5 Reserved (VGA palette snoop) .....fixed at 0
- 4 Memory Write and Invalidate . default=0 (disabled)
- 3 Reserved (special cycle monitoring) .....fixed at 0
- 2 Bus Master ..... default=0 (disabled)
- 1 Memory Space..... default=0 (disabled)
- 0 I/O Space ..... default=0 (disabled)

**Offset 7-6 - Status.....RWC**

- 15 Reserved (detected parity error)..... always reads 0
- 14 Signalled System Error..... default=0
- 13 Received Master Abort..... default=0
- 12 Received Target Abort ..... default=0
- 11 Signalled Target Abort..... default=0
- 10-9 DEVSEL# Timing
  - 00 Fast
  - 01 Medium .....default (fixed)
  - 10 Slow
  - 11 Reserved
- 8-0 Reserved ..... always reads 0

**Offset 8 - Revision ID (nnh)..... RO**

7-0 Silicon Revision Code (0 indicates first silicon)

**Offset 9 - Programming Interface (00h) ..... RO**

**Offset A - Sub Class Code (03h=USB Controller) ..... RO**

**Offset B - Base Class Code (0Ch=Serial Bus Controller)RO**

**Offset C - Cache Line Size (00h)..... RO**

**Offset D - Latency Timer ..... RW**

7-0 Timer Value ..... default = 16h

**Offset E - Header Type (00h)..... RO**

**Offset F - BIST (00h)..... RO**

**Offset 23-20 - USB I/O Register Base Address..... RW**

- 31-16 Reserved ..... always reads 0
- 15-5 USB I/O Register Base Address. Port Address for the base of the 32-byte USB I/O Register block, corresponding to AD[15:5]
- 4-0 00001b

**Offset 3C - Interrupt Line (00h)..... RW**

- 7-4 Reserved ..... always reads 0
- 3-0 USB Interrupt Routing ..... default = 16h
  - 0000 Disable..... default
  - 0001 IRQ1
  - 0010 Reserved
  - 0011 IRQ3
  - 0100 IRQ4
  - 0101 IRQ5
  - 0110 IRQ6
  - 0111 IRQ7
  - 1000 IRQ8
  - 1001 IRQ9
  - 1010 IRQ10
  - 1011 IRQ11
  - 1100 IRQ12
  - 1101 IRQ13
  - 1110 IRQ14
  - 1111 Disable

**Offset 3D - Interrupt Pin (04h)..... RO**

**USB-Specific Configuration Registers**

**Offset 40 - Miscellaneous Control 1.....RW**

- 7 PCI Memory Command Option**
  - 0 Support Memory-Read-Line, Memory-Read-Multiple, & Memory-Write-&-Invalidate.... def
  - 1 Only support Mem Read, Mem Write Cmds
- 6 Babble Option**
  - 0 Automatically disable babbled port when EOF babble occurs.....default
  - 1 Don't disable babbled port
- 5 PCI Parity Check Option**
  - 0 Disable PERR# generation.....default
  - 1 Enable parity check and PERR# generation
- 4 Frame Interval Select**
  - 0 1 ms frame .....default
  - 1 0.1 ms frame
- 3 USB Data Length Option**
  - 0 Support TD length up to 1280.....default
  - 1 Support TD length up to 1023
- 2 USB Power Management**
  - 0 Disable USB power management .....default
  - 1 Enable USB power management
- 1 DMA Option**
  - 0 8 DW burst access with better FIFO latency def
  - 1 16 DW burst access (original performance)
- 0 PCI Wait States**
  - 0 Zero wait .....default
  - 1 One wait

**Offset 41 - Miscellaneous Control 2 ..... RW**

- 7 USB 1.1 Improvement for EOP**
  - 0 USB Specification 1.1 Compliant..... default  
If a bit stuffing error occurs before EOP, the receiver will accept the packet
  - 1 USB Specification 1.0 Compliant  
If a bit stuffing error occurs before EOP, the receiver will ignore the packet
- 6-5 Reserved (Do Not Program) ..... default = 0**
- 4 Hold PCI Request for Successive Accesses**
  - 0 Disable
  - 1 Enable ..... default  
Setting this bit to "enable" causes the system to treat the USB request as higher priority
- 3 Frame Counter Test Mode**
  - 0 Disable ..... default
  - 1 Enable
- 2 Trap Option**
  - 0 Set trap 60/64 status bits only when trap 60/64 enable bits are set. .... default
  - 1 Set trap 60/64 status bits without checking enable bits
- 1 A20gate Pass Through Option**
  - 0 Pass through A20GATE command sequence defined in UHCI ..... default
  - 1 Don't pass through Write I/O port 64 (ff)
- 0 USB IRQ Test Mode**
  - 0 Normal Operation ..... default
  - 1 Generate USB IRQ

**Offset 42 - FIFO Control (CF/CG) .....RW**

- 7-4 **Reserved** ..... always reads 0
- 3-2 **Reserved (Do Not Program)**..... default = 0
- 1-0 **Release Continuous REQ After “N” PCICLKs**
  - 00 Do Not Release .....default
  - 01 N = 32 PCICLKs
  - 10 N = 64 PCICLKs
  - 11 N = 96 PCICLKs

**Offset 43 - FIFO Control II (CG) .....RW**

- 7-3 **Reserved** ..... always reads 0
- 2 **Issue CRS Error on FIFO Underrun**
  - 0 Disable .....default
  - 1 Enable
- 1-0 **Reserved** ..... always reads 0

**Offset 60 - Serial Bus Release Number .....RO**

- 7-0 **Release Number**..... always reads 10h

**Offset 83-80 – PM Capability (CF/CG).....RO**

- 31-0 **PM Capability** ..... always reads 00020001h

**Offset 84 – PM Capability Status (CF/CG).....RW**

- 7-0 **PM Capability Status**.....supports 00h and 11h only

**Offset C1-C0 - Legacy Support.....RO**

- 15-0 **UHCI v1.1 Compliant**..... always reads 2000h

**USB I/O Registers**

These registers are compliant with the UHCI v1.1 standard. Refer to the UHCI v1.1 specification for further details.

**I/O Offset 1-0 - USB Command**

**I/O Offset 3-2 - USB Status**

**I/O Offset 5-4 - USB Interrupt Enable**

**I/O Offset 7-6 - Frame Number**

**I/O Offset B-8 - Frame List Base Address**

**I/O Offset 0C - Start Of Frame Modify**

**I/O Offset 11-10 - Port 0 Status / Control**

**I/O Offset 13-12 - Port 1 Status / Control**

**Function 4 Regs - Power Management, SMBus and HWM**

This section describes the ACPI (Advanced Configuration and Power Interface) Power Management system of the VT82C686A which includes a System Management Bus (SMBus) interface controller and Hardware Monitoring (HWM) subsystem. The power management system of the VT82C686A supports both ACPI and legacy power management functions and is compatible with the APM v1.2 and ACPI v1.0 specifications.

**PCI Configuration Space Header**

**Offset 1-0 - Vendor ID .....RO**

0-7 Vendor ID ..... (1106h = VIA Technologies)

**Offset 3-2 - Device ID.....RO**

0-7 Device ID ..... (3057h = ACPI Power Mgmt)

**Offset 5-4 - Command.....RW**

- 15-8 Reserved ..... always reads 0
- 7 Address Stepping .....fixed at 0
- 6 Reserved (parity error response) .....fixed at 0
- 5 Reserved (VGA palette snoop) .....fixed at 0
- 4 Memory Write and Invalidate .....fixed at 0
- 3 Reserved (special cycle monitoring) .....fixed at 0
- 2 Bus Master .....fixed at 0
- 1 Memory Space.....fixed at 0
- 0 I/O Space .....fixed at 0

**Offset 7-6 - Status.....RWC**

- 15 Detected Parity Error ..... always reads 0
- 14 Signalled System Error ..... always reads 0
- 13 Received Master Abort..... always reads 0
- 12 Received Target Abort ..... always reads 0
- 11 Signalled Target Abort ..... always reads 0
- 10-9 DEVSEL# Timing
  - 00 Fast
  - 01 Medium .....default (fixed)
  - 10 Slow
  - 11 Reserved
- 8 Data Parity Detected..... always reads 0
- 7 Fast Back to Back Capable ..... always reads 1
- 6-0 Reserved ..... always reads 0

**Offset 8 - Revision ID (nnh)..... RO**

7-0 Silicon Revision Code

**Offset 9 - Programming Interface (00h) ..... RO**

The value returned by this register may be changed by writing the desired value to PCI Configuration Function 4 offset 61h.

**Offset A - Sub Class Code (00h)..... RO**

The value returned by this register may be changed by writing the desired value to PCI Configuration Function 4 offset 62h.

**Offset B - Base Class Code (00h)..... RO**

The value returned by this register may be changed by writing the desired value to PCI Configuration Function 4 offset 63h.

**Offset 0D - Latency Timer ..... RW**

7-0 Timer Value ..... default = 0

**Offset 0E - Header Type (00h)..... RO**

**Power Management-Specific PCI Configuration Registers**

**Offset 40 – General Configuration 0 .....RW**

- 7 Thermal Alarm Source Select**
  - 0 From pin T11 (Function 0 Rx74[1] must be set to define the pin as THRM#).....default
  - 1 From any of the three internal temperature sensing circuits (see Rx43 and Rx44 of Hardware Monitoring configuration space)
- 6 Sleep Button**
  - 0 Disable .....default
  - 1 Sleep Button is on IRQ6 pin (pin G1)
- 5 Debounce LID and PWRBTN# Inputs for 200us**
  - 0 Disable .....default
  - 1 Enable
- 4 Reserved** ..... always reads 0
- 3 Microsoft Sound Monitor in Audio Access**
  - 0 Disable .....default
  - 1 Enable
- 2 Game Port Monitor in Audio Access**
  - 0 Disable .....default
  - 1 Enable
- 1 SoundBlaster Monitor in Audio Access**
  - 0 Disable .....default
  - 1 Enable
- 0 MIDI Monitor in Audio Access**
  - 0 Disable .....default
  - 1 Enable

**Offset 41 - General Configuration 1..... RW**

- 7 I/O Enable for ACPI I/O Base**
  - 0 Disable access to ACPI I/O block..... default
  - 1 Allow access to Power Management I/O Register Block (see offset 4B-48 to set the base address for this register block). The definitions of the registers in the Power Management I/O Register Block are included later in this document, following the Power Management Subsystem overview.
- 6 ACPI Timer Reset**
  - 0 Normal Timer Operation ..... default
  - 1 Reset Timer
- 5-4 PMU Timer Test Mode (Do Not Program) ....def = 0**
- 3 ACPI Timer Count Select**
  - 0 24-bit Timer..... default
  - 1 32-bit Timer
- 2 RTC Enable Signal Gated with PSON (SUSC#) in Soft-Off Mode**
  - 0 Disable..... default
  - 1 Enable
- 1 Clock Throttling Clock Selection**
  - 0 32 usec (512 usec cycle time)..... default
  - 1 1 msec (16 msec cycle time)
- 0 DEVSEL# Test Mode (Do Not Program).....def = 0**



**Offset 42 - ACPI Interrupt Select .....RW**

- 7 ATX / AT Power Indicator..... RO
  - 0 ATX
  - 1 AT
- 6 SUSC# State..... RO
- 5 Reserved ..... always reads 0
- 4 SUSC# AC-Power-On Default Value ..... RO  
This bit is written at RTC Index 0D bit-7.
- 3-0 SCI Interrupt Assignment
  - 0000 Disable .....default
  - 0001 IRQ1
  - 0010 Reserved
  - 0011 IRQ3
  - 0100 IRQ4
  - 0101 IRQ5
  - 0110 IRQ6
  - 0111 IRQ7
  - 1000 IRQ8
  - 1001 IRQ9
  - 1010 IRQ10
  - 1011 IRQ11
  - 1100 IRQ12
  - 1101 IRQ13
  - 1110 IRQ14
  - 1111 IRQ15

**Offset 43 – Internal Timer Read Test.....RO**

- 7-0 Internal Timer Read Test

**Offset 45-44 - Primary Interrupt Channel (0000h) ..... RW**

- 15 1/0 = Ena/Disa IRQ15 as Primary Intrpt Channel
- 14 1/0 = Ena/Disa IRQ14 as Primary Intrpt Channel
- 13 1/0 = Ena/Disa IRQ13 as Primary Intrpt Channel
- 12 1/0 = Ena/Disa IRQ12 as Primary Intrpt Channel
- 11 1/0 = Ena/Disa IRQ11 as Primary Intrpt Channel
- 10 1/0 = Ena/Disa IRQ10 as Primary Intrpt Channel
- 9 1/0 = Ena/Disa IRQ9 as Primary Intrpt Channel
- 8 1/0 = Ena/Disa IRQ8 as Primary Intrpt Channel
- 7 1/0 = Ena/Disa IRQ7 as Primary Intrpt Channel
- 6 1/0 = Ena/Disa IRQ6 as Primary Intrpt Channel
- 5 1/0 = Ena/Disa IRQ5 as Primary Intrpt Channel
- 4 1/0 = Ena/Disa IRQ4 as Primary Intrpt Channel
- 3 1/0 = Ena/Disa IRQ3 as Primary Intrpt Channel
- 2 Reserved .....always reads 0
- 1 1/0 = Ena/Disa IRQ1 as Primary Intrpt Channel
- 0 1/0 = Ena/Disa IRQ0 as Primary Intrpt Channel

**Offset 47-46 - Secondary Interrupt Channel (0000h).... RW**

- 15 1/0 = Ena/Disa IRQ15 as Secondary Intr Channel
- 14 1/0 = Ena/Disa IRQ14 as Secondary Intr Channel
- 13 1/0 = Ena/Disa IRQ13 as Secondary Intr Channel
- 12 1/0 = Ena/Disa IRQ12 as Secondary Intr Channel
- 11 1/0 = Ena/Disa IRQ11 as Secondary Intr Channel
- 10 1/0 = Ena/Disa IRQ10 as Secondary Intr Channel
- 9 1/0 = Ena/Disa IRQ9 as Secondary Intr Channel
- 8 1/0 = Ena/Disa IRQ8 as Secondary Intr Channel
- 7 1/0 = Ena/Disa IRQ7 as Secondary Intr Channel
- 6 1/0 = Ena/Disa IRQ6 as Secondary Intr Channel
- 5 1/0 = Ena/Disa IRQ5 as Secondary Intr Channel
- 4 1/0 = Ena/Disa IRQ4 as Secondary Intr Channel
- 3 1/0 = Ena/Disa IRQ3 as Secondary Intr Channel
- 2 Reserved .....always reads 0
- 1 1/0 = Ena/Disa IRQ1 as Secondary Intr Channel
- 0 1/0 = Ena/Disa IRQ0 as Secondary Intr Channel

**Offset 4B-48 – Power Management I/O Base .....RW**

- 31-16 Reserved** ..... always reads 0
- 15-7 Power Management I/O Register Base Address.**  
Port Address for the base of the 128-byte Power Management I/O Register block, corresponding to AD[15:7]. The "I/O Space" bit at offset 41 bit-7 enables access to this register block. The definitions of the registers in the Power Management I/O Register Block are included in the following section this document.
- 6-0 0000001b**

**Offset 4C – Host Bus Power Management Control.....RW**

- 7-4 Thermal Duty Cycle (THM\_DTY)**  
This 4-bit field determines the duty cycle of the STPCLK# signal when the THRM# pin is asserted low. The field is decoded as follows:  
0000 Reserved.....default  
0001 0-6.25%  
0010 6.25-12.50%  
0011 18.75-25.00%  
0100 31.25-37.50%  
0101 37.50-43.75%  
0110 43.75-50.00%  
0111 50.00-56.25%  
1000 56.25-62.50%  
1001 62.50-68.75%  
1010 68.75-75.00%  
1011 75.00-87.50%  
1100 75.00-81.25%  
1101 81.25-87.50%  
1110 87.50-93.75%  
1111 93.75-100%
- 3 THRM Enable**  
0 Disable .....default  
1 Enable
- 2 Frame Input as Resume Event in C3**  
0 Disable .....default  
1 Enable
- 1 Reserved** ..... always reads 0
- 0 CPU Stop Grant Cycle Select**  
0 From Halt and Stop Grant Cycle .....default  
1 From Stop Grant Cycle  
This bit is combined with I/O space Rx2C[3] for controlling the start of CPUSTP# assertion during system suspend mode:  

Rx2C[3]	Rx4C[0]	
Function 4	Function 4	
<u>I/O Space</u>	<u>Cfg Space</u>	<u>CPUSTP# Assertion</u>
0	x	Immediate
1	0	Wait for CPU Halt / Stop Grant cycle
1	1	Wait for CPU Stop Grant cycle

**Offset 4D – Throttle / Clock Stop Control..... RW**

- 7 Throttle Timer Reset**.....def = 0
- 6-5 Throttle Timer**  
0x 4-Bit ..... default  
10 3-Bit  
11 2-Bit
- 4 Fast Clock (7.5us) as Throttle Timer Tick**  
0 Disable..... default  
1 Enable
- 3 SMI Pullup (CG)**  
0 Disable..... default  
1 Enable (set this bit for socket-370 coppermine)
- 2 Internal Clock Stop for PCI Idle**  
0 Disable..... default  
1 Enable
- 1 Internal Clock Stop During C3**  
0 Disable..... default  
1 Enable
- 0 Internal Clock Stop During Suspend**  
0 Disable..... default  
1 Enable

**Offset 53-50 - GP Timer Control (0000 0000h) .....RW**

- 31-30 Conserve Mode Timer Count Value**
  - 00 1/16 second .....default
  - 01 1/8 second
  - 10 1 second
  - 11 1 minute

**29 Conserve Mode Status**  
This bit reads 1 when in Conserve Mode

- 28 Conserve Mode Enable**
  - 0 Disable .....default
  - 1 Enable

- 27-26 Secondary Event Timer Count Value**
  - 00 2 milliseconds.....default
  - 01 64 milliseconds
  - 10 1/2 second
  - 11 by EOI + 0.25 milliseconds

**25 Secondary Event Occurred Status**  
This bit reads 1 to indicate that a secondary event has occurred (to resume the system from suspend) and the secondary event timer is counting down.

- 24 Secondary Event Timer Enable**
  - 0 Disable .....default
  - 1 Enable

**23-16 GP1 Timer Count Value** (base defined by bits 5-4)  
Write to load count value; Read to get current count

**15-8 GP0 Timer Count Value** (base defined by bits 1-0)  
Write to load count value; Read to get current count

**7 GP1 Timer Start**  
On setting this bit to 1, the GP1 timer loads the value defined by bits 23-16 of this register and starts counting down. The GP1 timer is reloaded at the occurrence of certain peripheral events enabled in the GP Timer Reload Enable Register (Power Management I/O Space Offset 38h). If no such event occurs and the GP1 timer counts down to zero, then the GP1 Timer Timeout Status bit is set to one (bit-3 of the Global Status register at Power Management Register I/O Space Offset 28h). Additionally, if the GP1 Timer Timeout Enable bit is set (bit-3 of the Global Enable register at Power Management Register I/O Space Offset 2Ah), then an SMI is generated.

- 6 GP1 Timer Automatic Reload**
  - 0 GP1 Timer stops at 0 .....default
  - 1 Reload GP1 timer automatically after counting down to 0

- 5-4 GP1 Timer Base**
  - 00 Disable .....default
  - 01 1/4 msec
  - 10 1 second
  - 11 1 minute

**3 GP0 Timer Start**  
On setting this bit to 1, the GP0 timer loads the value defined by bits 15-8 of this register and starts counting down. The GP0 timer is reloaded at the occurrence of certain peripheral events enabled in the GP Timer Reload Enable Register (Power Management I/O Space Offset 38h). If no such event occurs and the GP0 timer counts down to zero, then the GP0 Timer Timeout Status bit is set to one (bit-2 of the Global Status register at Power Management Register I/O Space Offset 28h). Additionally, if the GP0 Timer Timeout Enable bit is set (bit-2 of the Global Enable register at Power Management Register I/O Space Offset 2Ah), then an SMI is generated.

- 2 GP0 Timer Automatic Reload**
  - 0 GP0 Timer stops at 0 ..... default
  - 1 Reload GP0 timer automatically after counting down to 0

- 1-0 GP0 Timer Base**
  - 00 Disable ..... default
  - 01 1/16 second
  - 10 1 second
  - 11 1 minute

**Offset 54 – Power Well Control ..... WO**

- 7 SMBus Clock Select**
  - 0 SMBus Clock from 14.31818 MHz Divider def
  - 1 SMBus Clock from RTC 32.768 KHz
- 6 STR Power Well Output Gating**
  - 0 Disable .....default
  - 1 Enable
- 5 SUSC# = 0 for STR**
  - 0 Disable .....default
  - 1 Enable
- 4 SUSST1# / GPO3 Select (Pin V10)**
  - 0 SUSST1#.....default
  - 1 GPO3
- 3 GPO2 / SUSB# Select (Pin W9)**
  - 0 SUSB#.....default
  - 1 GPO2

Before chip rev C, this definition was reversed  
See also Function 0 Rx74[7] and 77[4]
- 2 GPO1 / SUSA# Select (Pin V9)**
  - 0 SUSA# .....default
  - 1 GPO1

Before chip rev C, this definition was reversed  
See also Function 0 Rx74[7] and 77[4]
- 1-0 GPO0 (SLOWCLK) Output Selection (Pin T8)**
  - 00 From GPO0 (PMU I/O Rx4C[0]).....default
  - 01 1 Hz
  - 10 4 Hz
  - 11 16 Hz

**Offset 55 – USB Wakeup..... RW**

- 7-3 Reserved** .....always reads 0
- 2 Deassert SUSST1# Before PWRGD Rising for S5 Wakeup (CG Rev C)**
  - 0 Disable..... default
  - 1 Enable
- 1 Reserved** .....always reads 0
- 0 USB Wakeup for STR/STD/Soff**
  - 0 Disable..... default
  - 1 Enable

**Offset 58 – GP2 / GP3 Timer Control .....RW**

**7 GP3 Timer Start**

On setting this bit to 1, the GP3 timer loads the value defined by Rx5A and starts counting down. The GP3 timer is reloaded at the occurrence of certain events enabled in the GP Timer Reload Enable Register (Power Management I/O Space Offset 38h). If no such event occurs and the GP3 timer counts down to zero, then the GP3 Timer Timeout Status bit is set to one (bit-13 of the Global Status register at Power Management Register I/O Space Offset 28h). Additionally, if the GP3 Timer Timeout Enable bit is set (bit-13 of the Global Enable register at Power Management Register I/O Space Offset 2Ah), then an SMI is generated.

**6 GP3 Timer Automatic Reload**

- 0 GP3 Timer stops at 0 .....default
- 1 Reload GP3 timer automatically after counting down to 0

**5-4 GP3 Timer Tick Select**

- 00 Disable .....default
- 01 1/4 millisecond
- 10 1 second
- 11 1 minute

**3 GP2 Timer Start**

On setting this bit to 1, the GP2 timer loads the value defined by Rx59 and starts counting down. The GP2 timer is reloaded at the occurrence of certain events enabled in the GP Timer Reload Enable Register (Power Management I/O Space Offset 38h). If no such event occurs and the GP2 timer counts down to zero, then the GP2 Timer Timeout Status bit is set to one (bit-12 of the Global Status register at Power Management Register I/O Space Offset 28h). Additionally, if the GP2 Timer Timeout Enable bit is set (bit-12 of the Global Enable register at Power Management Register I/O Space Offset 2Ah), then an SMI is generated.

**2 GP2 Timer Automatic Reload**

- 0 GP2 Timer stops at 0 .....default
- 1 Reload GP2 timer automatically after counting down to 0

**1-0 GP2 Timer Tick Select**

- 00 Disable .....default
- 01 1/16 second
- 10 1 second
- 11 1 minute

**Offset 59 – GP2 Timer..... RW**

- 7 Write: GP2 Timer Load Value.....default = 0
- Read: GP2 Timer Current Count

**Offset 5A – GP3 Timer..... RW**

- 7 Write: GP3 Timer Load Value.....default = 0
- Read: GP3 Timer Current Count

**Offset 61 – Program Interface Read Value..... WO**

**7-0 Rx09 Read Value**

The value returned by the register at offset 9h (Programming Interface) may be changed by writing the desired value to this location.

**Offset 62 - Sub Class Read Value..... WO**

**7-0 Rx0A Read Value**

The value returned by the register at offset 0Ah (Sub Class Code) may be changed by writing the desired value to this location.

**Offset 63 - Base Class Read Value ..... WO**

**7-0 Rx0B Read Value**

The value returned by the register at offset 0Bh (Base Class Code) may be changed by writing the desired value to this location.

**Hardware-Monitor-Specific Configuration Registers**

**Offset 71-70 – Hardware Monitor I/O Base .....RW**

- 15-7 I/O Base (128-byte I/O space) ..... default = 0
- 6-0 Fixed ..... always reads 0000001b

**Offset 74 –Hardware Monitor Control .....RW**

- 7-4 Reserved ..... always reads 0
- 3 **Hardware Monitoring Interrupt**
  - 0 SMI .....default
  - 1 SCI
- 2-1 Reserved ..... always reads 0
- 0 **Hardware Monitoring I/O Enable**
  - 0 Disable hardware monitor functions.....default
  - 1 Enable hardware monitor functions

**System Management Bus-Specific Configuration Registers**

**Offset 93-90 – SMBus I/O Base ..... RW**

- 31-16 Reserved ..... always reads 0
- 15-4 I/O Base (16-byte I/O space)..... default = 00h
- 3-0 Fixed ..... always reads 0001b

**Offset D2 – SMBus Host Configuration ..... RW**

- 7-4 Reserved ..... always reads 0
- 3 **SMBus Interrupt Select**
  - 0 SMI ..... default
  - 1 SCI
- 2 Reserved ..... always reads 0
- 1 **SMBus IRQ**
  - 0 Disable..... default
  - 1 Enable
- 0 **SMBus Host Controller Enable**
  - 0 Disable SMB controller functions ..... default
  - 1 Enable SMB controller functions

**Offset D3 – SMBus Host Slave Command..... RW**

- 7-0 SMBus Host Slave Command Code..... default=0

**Offset D4 – SMBus Slave Address for Port 1..... RW**

- 7-0 SMBus Slave Address for Port 1..... default=0
- Bit-0 must be set to 0 for proper operation

**Offset D5 – SMBus Slave Address for Port 2..... RW**

- 7-0 SMBus Slave Address for Port 2..... default=0
- Bit-0 must be set to 0 for proper operation

**Offset D6 – SMBus Revision ID ..... RO**

- 7-0 SMBus Revision Code



**Power Management I/O-Space Registers**

**Basic Power Management Control and Status**

**I/O Offset 1-0 - Power Management Status .....RWC**

The bits in this register are set only by hardware and can be reset by software by writing a one to the desired bit position.

- 15 Wakeup Status (WAK\_STS) ..... default = 0**  
This bit is set when the system is in the suspend state and an enabled resume event occurs. Upon setting this bit, the system automatically transitions from the suspend state to the normal working state (from C3 to C0 for the processor).
- 14-12 Reserved ..... always reads 0**
- 11 Abnormal Power-Off (APO\_STS)..... default = 0**
- 10 RTC Status (RTC\_STS) ..... default = 0**  
This bit is set when the RTC generates an alarm (on assertion of the RTC IRQ signal).
- 9 Sleep Button Status (SB\_STS)..... default = 0**  
This bit is set when the sleep button (SLPBTN# / IRQ6 / GPI4) is pressed.
- 8 Power Button Status (PB\_STS)..... default = 0**  
This bit is set when the PWRBTN# signal is asserted LOW. If the PWRBTN# signal is held LOW for more than four seconds, this bit is cleared and the system will transition into the soft off state.
- 7-6 Reserved ..... always reads 0**
- 5 Global Status (GBL\_STS)..... default = 0**  
This bit is set by hardware when BIOS\_RLS is set (typically by an SMI routine to release control of the SCI/SMI lock). When this bit is cleared by software (by writing a one to this bit position) the BIOS\_RLS bit is also cleared at the same time by hardware.
- 4 Bus Master Status (BM\_STS) ..... default = 0**  
This bit is set when a system bus master requests the system bus. All PCI master, ISA master and ISA DMA devices are included.
- 3-1 Reserved ..... always reads 0**
- 0 ACPI Timer Carry Status (TMR\_STS) .. default = 0**  
The bit is set when the 23<sup>rd</sup> (31st) bit of the 24 (32) bit ACPI power management timer changes.

**I/O Offset 3-2 - Power Management Enable ..... RW**

The bits in this register correspond to the bits in the Power Management Status Register at offset 1-0.

- 15 Reserved ..... always reads 0**
- 14-12 Reserved ..... always reads 0**
- 11 Reserved ..... always reads 0**
- 10 RTC Enable (RTC\_EN)..... default = 0**  
This bit may be set to trigger either an SCI or an SMI (depending on the setting of the SCI\_EN bit) to be generated when the RTC\_STS bit is set.
- 9 Sleep Button Enable (SB\_EN) ..... default = 0**  
This bit may be set to trigger either an SCI or SMI when the SB\_STS bit is set.
- 8 Power Button Enable (PB\_EN) ..... default = 0**  
This bit may be set to trigger either an SCI or an SMI (depending on the setting of the SCI\_EN bit) to be generated when the PB\_STS bit is set.
- 7-6 Reserved ..... always reads 0**
- 5 Global Enable (GBL\_EN)..... default = 0**  
This bit may be set to trigger either an SCI or an SMI (depending on the setting of the SCI\_EN bit) to be generated when the GBL\_STS bit is set.
- 4 Reserved ..... always reads 0**
- 3-1 Reserved ..... always reads 0**
- 0 ACPI Timer Enable (TMR\_EN) ..... default = 0**  
This bit may be set to trigger either an SCI or an SMI (depending on the setting of the SCI\_EN bit) to be generated when the TMR\_STS bit is set.

**I/O Offset 5-4 - Power Management Control .....RW**

**15 Soft Resume**

**14 Reserved** ..... always reads 0

**13 Sleep Enable (SLP\_EN)**..... always reads 0

This is a write-only bit; reads from this bit always return zero. Writing a one to this bit causes the system to sequence into the sleep (suspend) state defined by the SLP\_TYP field.

**12-10 Sleep Type (SLP\_TYP)**

- 000 Normal On
- 001 Suspend to RAM (STR)
- 010 Suspend to Disk (STD) (also called Soft Off).  
The VCC power plane is turned off while the VCCS and VBAT planes remain on.
- 011 Reserved
- 100 Power On Suspend without Reset
- 101 Power On Suspend with CPU Reset
- 110 Power On Suspend with CPU/PCI Reset
- 111 Reserved

In any sleep state, there is minimal interface between powered and non-powered planes so that the effort for hardware design may be well managed.

**9-3 Reserved** ..... always reads 0

**2 Global Release (GBL\_RLS)** ..... **WO**, default = 0

This bit is set by ACPI software to indicate the release of the SCI / SMI lock. Upon setting of this bit, the hardware automatically sets the BIOS\_STS bit. The bit is cleared by hardware when the BIOS\_STS bit is cleared by software. Note that the setting of this bit will cause an SMI to be generated if the BIOS\_EN bit is set (bit-5 of the Global Enable register at offset 2Ah).

**1 Bus Master Reload (BMS\_RLD)**

- 0 Bus master requests are ignored by power management logic.....default
- 1 Bus master requests transition the processor from the C3 state to the C0 state

**0 SCI Enable (SCI\_EN)**

Selects the power management event to generate either an SCI or SMI:

- 0 Generate SCI.....default
- 1 Generate SMI

Note that certain power management events can be programmed individually to generate an SCI or SMI independent of the setting of this bit (refer to the General Purpose SCI Enable and General Purpose SMI Enable registers at offsets 22 and 24). Also, TMR\_STS & GBL\_STS always generate SCI and BIOS\_STS always generates SMI.

**I/O Offset 0B-08 - Power Management Timer ..... RW**

**31-24 Extended Timer Value (ETM\_VAL)**

This field reads back 0 if the 24-bit timer option is selected (Rx41 bit-3).

**23-0 Timer Value (TMR\_VAL)**

This read-only field returns the running count of the power management timer. This is a 24/32-bit counter that runs off a 3.579545 MHz clock, and counts while in the S0 (working) system state. The timer is reset to an initial value of zero during a reset, and then continues counting until the 14.31818 MHz input to the chip is stopped. If the clock is restarted without a reset, then the counter will continue counting from where it stopped.

**Processor Power Management Registers**

**I/O Offset 13-10 - Processor & PCI Bus Control.....RW**

- 31-12 **Reserved** ..... always reads 0
- 11 **PCI Stop (PCISTP# asserted) when PCKRUN# is Deasserted (PCI\_STP)**
  - 0 Enable.....default
  - 1 Disable
- 10 **PCI Bus Clock Run Without Stop (PCI\_RUN)**
  - 0 PCKRUN# will be de-activated after the PCI bus is idle for 26 clocks.....default
  - 1 PCKRUN# is always asserted
- 9 **Host Clock Stop Enable (HOST\_STP)**
  - 0 STPCLK# will be asserted in the C3 state, but the CPU clock is not stopped .....default
  - 1 CPU clock is stopped in the C3 state
- 8 **Assert SLP# for Processor Level 3 Read**
  - 0 Disable .....default
  - 1 Enable

Used in Slot-1 systems only.
- 7-5 **Reserved** ..... always reads 0
- 4 **Throttling Enable (THT\_EN)**

Setting this bit starts clock throttling (modulating the STPCLK# signal) regardless of the CPU state. The throttling duty cycle is determined by bits 3-0 of this register.
- 3-0 **Throttling Duty Cycle (THT\_DTY)**

This 4-bit field determines the duty cycle of the STPCLK# signal when the system is in throttling mode (the "Throttling Enable" bit is set to one). The duty cycle indicates the percentage of time the STPCLK# signal is asserted while the Throttling Enable bit is set. The field is decoded as follows:

  - 0000 Reserved
  - 0001 0-6.25%
  - 0010 6.25-12.50%
  - 0011 18.75-25.00%
  - 0100 31.25-37.50%
  - 0101 37.50-43.75%
  - 0110 43.75-50.00%
  - 0111 50.00-56.25%
  - 1000 56.25-62.50%
  - 1001 62.50-68.75%
  - 1010 68.75-75.00%
  - 1011 75.00-87.50%
  - 1100 75.00-81.25%
  - 1101 81.25-87.50%
  - 1110 87.50-93.75%
  - 1111 93.75-100%

**I/O Offset 14 - Processor Level 2..... RO**

- 7-0 **Level 2** .....always reads 0
- Reads from this register put the processor into the Stop Grant state (the VT82C686A asserts STPCLK# to suspend the processor). Wake up from Stop Grant state is by interrupt (INTR, SMI, and SCI).

Reads from this register return all zeros; writes to this register have no effect.

**I/O Offset 15 - Processor Level 3..... RO**

- 7-0 **Level 3** .....always reads 0
- Reads from this register put the processor in the C3 clock state with the STPCLK# signal asserted. If Rx10[9] = 1 then the CPU clock is also stopped by asserting CPUTP#. Wakeup from the C3 state is by interrupt (INTR, SMI, and SCI).

Reads from this register return all zeros; writes to this register have no effect.

**General Purpose Power Management Registers**

**I/O Offset 21-20 - General Purpose Status (GP\_STS).RWC**

- 15 **Reserved** ..... always reads 0
- 14 **USB Wake-Up Status (UWAK\_STS)**  
For STR / STD / Soff
- 13 **AC97 Wake-Up Status (AWAK\_STS)**  
Can be set only in suspend mode
- 12 **Battery Low Status (BL\_STS)**  
This bit is set when the BATLOW# input is asserted low.
- 11 **Notebook Lid Status (LID\_STS)**  
This bit is set when the LID input detects the edge selected by Rx2C bit-7 (0=rising, 1=falling).
- 10 **Thermal Detect Status (THRM\_STS)**  
This bit is set when the THRM input detects the edge selected by Rx2C bit-6 (0=rising, 1=falling).
- 9 **USB Resume Status (USB\_STS)**  
This bit is set when a USB peripheral generates a resume event.
- 8 **Ring Status (RING\_STS)**  
This bit is set when the RING# input is asserted low.
- 7 **GPI18 Toggle Status (GPI18\_STS)**  
This bit is set when the GPI18 pin is toggled.
- 6 **GPI6 / EXTSMI6 Toggle Status (GPI6\_STS)**  
This bit is set when the GPI6 pin is toggled.
- 5 **GPI5 Toggle Status (GPI5\_STS)**  
This bit is set when the GPI5 pin is toggled.
- 4 **GPI4 / EXTSMI4 Toggle Status (GPI4\_STS)**  
This bit is set when the GPI4 pin is toggled.
- 3 **GPI17 Toggle Status (GPI17\_STS)**  
This bit is set when the GPI17 pin is toggled.
- 2 **GPI16 Toggle Status (GPI16\_STS)**  
This bit is set when the GPI16 pin is toggled.
- 1 **GPI1 Toggle Status (GPI1\_STS)**  
This bit is set when the GPI1 pin is toggled.
- 0 **EXTSMI# Status (EXT\_STS)**  
This bit is set when the EXTSMI# pin is asserted low.

Note that the above bits correspond one for one with the bits of the General Purpose SCI Enable and General Purpose SMI Enable registers at offsets 22 and 24: an SCI or SMI is generated if the corresponding bit of the General Purpose SCI or SMI Enable registers, respectively, is set to one.

The above bits are set by hardware only and can only be cleared by writing a one to the desired bit.

**I/O Offset 23-22 - General Purpose SCI Enable ..... RW**

- 15 **Reserved** ..... always reads 0
- 14 **Enable SCI on setting of the UWAK\_STS bit** def=0
- 13 **Enable SCI on setting of the AWAK\_STS bit** def=0
- 12 **Enable SCI on setting of the BL\_STS bit** .....def=0
- 11 **Enable SCI on setting of the LID\_STS bit** .....def=0
- 10 **Enable SCI on setting of the THRM\_STS bit** def=0
- 9 **Enable SCI on setting of the USB\_STS bit** ....def=0
- 8 **Enable SCI on setting of the RING\_STS bit** .def=0
- 7 **Enable SCI on setting of the GPI18\_STS bit**..def=0
- 6 **Enable SCI on setting of the GPI6\_STS bit**....def=0
- 5 **Enable SCI on setting of the GPI5\_STS bit**....def=0
- 4 **Enable SCI on setting of the GPI4\_STS bit**....def=0
- 3 **Enable SCI on setting of the GPI17\_STS bit**..def=0
- 2 **Enable SCI on setting of the GPI16\_STS bit**..def=0
- 1 **Enable SCI on setting of the GPI1\_STS bit**....def=0
- 0 **Enable SCI on setting of the EXT\_STS bit** ....def=0

These bits allow generation of an SCI using a separate set of conditions from those used for generating an SMI.

**I/O Offset 25-24 - General Purpose SMI Enable ..... RW**

- 15-14 **Reserved** ..... always reads 0
- 13 **Enable SMI on setting of the AWAK\_STS bit** def=0
- 12 **Enable SMI on setting of the BL\_STS bit** .....def=0
- 11 **Enable SMI on setting of the LID\_STS bit** ....def=0
- 10 **Enable SMI on setting of the THRM\_STS bit** def=0
- 9 **Enable SMI on setting of the USB\_STS bit** ...def=0
- 8 **Enable SMI on setting of the RING\_STS bit** def=0
- 7 **Enable SMI on setting of the GPI18\_STS bit**..def=0
- 6 **Enable SMI on setting of the GPI6\_STS bit**...def=0
- 5 **Enable SMI on setting of the GPI5\_STS bit**...def=0
- 4 **Enable SMI on setting of the GPI4\_STS bit**...def=0
- 3 **Enable SMI on setting of the GPI17\_STS bit**..def=0
- 2 **Enable SMI on setting of the GPI16\_STS bit**..def=0
- 1 **Enable SMI on setting of the GPI1\_STS bit**...def=0
- 0 **Enable SMI on setting of the EXT\_STS bit**....def=0

These bits allow generation of an SMI using a separate set of conditions from those used for generating an SCI.

**Generic Power Management Registers**

**I/O Offset 29-28 - Global Status.....RWC**

- 15 **GPIO Range 1 Access Status (GR1\_STS)** ..... def=0
- 14 **GPIO Range 0 Access Status (GR0\_STS)** ..... def=0
- 13 **GP3 Timer Timeout Status (G3TO\_STS)** ..... def=0
- 12 **GP2 Timer Timeout Status (G2TO\_STS)** ..... def=0
- 11 **SERIRQ SMI Status (SSMI\_STS)**..... def=0
- 10-9 **Reserved** ..... always reads 0
- 8 **PCKRUN# Resume Status (PRRSM\_STS)**.... def=0  
This bit is set when PCI bus peripherals wake up the system by asserting PCKRUN#
- 7 **Primary IRQ Resume Status (PIRSM\_STS)** . def=0  
This bit is set at the occurrence of primary IRQs as defined in Rx45-44 of PCI configuration space
- 6 **Software SMI Status (SW\_SMI\_STS)**..... def=0  
This bit is set when the SMI\_CMD port (offset 2F) is written.
- 5 **BIOS Status (BIOS\_STS)**..... def=0  
This bit is set when the GBL\_RLS bit is set to one (typically by the ACPI software to release control of the SCI/SMI lock). When this bit is reset (by writing a one to this bit position) the GBL\_RLS bit is reset at the same time by hardware.
- 4 **Legacy USB Status (LEG\_USB\_STS)** ..... def=0  
This bit is set when a legacy USB event occurs.
- 3 **GP1 Timer Time Out Status (GP1TO\_STS)**.. def=0  
This bit is set when the GP1 timer times out.
- 2 **GP0 Timer Time Out Status (GP0TO\_STS)**.. def=0  
This bit is set when the GP0 timer times out.
- 1 **Secondary Event Timer Time Out Status (STTO\_STS)**..... def=0  
This bit is set when the secondary event timer times out.
- 0 **Primary Activity Status (PACT\_STS)**..... def=0  
This bit is set at the occurrence of any enabled primary system activity (see the Primary Activity Detect Status register at offset 30h and the Primary Activity Detect Enable register at offset 34h). After checking this bit, software can check the status bits in the Primary Activity Detect Status register at offset 30h to identify the specific source of the primary event. Note that setting this bit can be enabled to reload the GP0 timer (see bit-0 of the GP Timer Reload Enable register at offset 38).

**I/O Offset 2B-2A - Global Enable ..... RW**

- 15 **GPIO Range 1 SMI Enable (GR1\_EN)** ..... def=0
- 14 **GPIO Range 0 SMI Enable (GR0\_EN)** ..... def=0
- 13 **GP3 Timer Timeout SMI Enable (G3TO\_EN)** def=0
- 12 **GP2 Timer Timeout SMI Enable (G2TO\_EN)** def=0
- 11 **SERIRQ SMI Enable (SSMI\_EN)** ..... def=0
- 10-9 **Reserved** ..... always reads 0
- 8 **PCKRUN# Resume Enable (PRRSM\_EN)** .... def=0  
This bit may be set to trigger an SMI to be generated when the PRRSM\_STS bit is set.
- 7 **Primary IRQ Resume Enable (PIRSM\_EN)**.. def=0  
This bit may be set to trigger an SMI to be generated when the PIRSM\_STS bit is set.
- 6 **SMI on Software SMI (SW\_SMI\_EN)** ..... def=0  
This bit may be set to trigger an SMI to be generated when the SW\_SMI\_STS bit is set.
- 5 **SMI on BIOS Status (BIOS\_EN)** ..... def=0  
This bit may be set to trigger an SMI to be generated when the BIOS\_STS bit is set.
- 4 **SMI on Legacy USB (LEG\_USB\_EN)**..... def=0  
This bit may be set to trigger an SMI to be generated when the LEG\_USB\_STS bit is set.
- 3 **SMI on GP1 Timer Time Out (GP1TO\_EN)** . def=0  
This bit may be set to trigger an SMI to be generated when the GP1TO\_STS bit is set.
- 2 **SMI on GP0 Timer Time Out (GP0TO\_EN)** . def=0  
This bit may be set to trigger an SMI to be generated when the GP0TO\_STS bit is set.
- 1 **SMI on Secondary Event Timer Time Out (STTO\_EN)** ..... def=0  
This bit may be set to trigger an SMI to be generated when the STTO\_STS bit is set.
- 0 **SMI on Primary Activity (PACT\_EN)** ..... def=0  
This bit may be set to trigger an SMI to be generated when the PACT\_STS bit is set.

Note that SMI can be generated based on the setting of any of the above bits (see the offset 2Ah Global Enable register bit descriptions in the right hand column of this page).

The bits in this register are set by hardware only and can only be cleared by writing a one to the desired bit position.

**I/O Offset 2D-2C - Global Control (GBL\_CTL) .....RW**

- 15-12 **Reserved** ..... always reads 0
- 11 **IDE Secondary Bus Power-Off**
  - 0 Disable .....default
  - 1 Enable
- 10 **IDE Primary Bus Power-Off**
  - 0 Disable .....default
  - 1 Enable
- 9 **Reserved** ..... always reads 0
- 8 **SMI Active (INSMI)**
  - 0 SMI Inactive.....default
  - 1 SMI Active. If the SMIIG bit is set, this bit needs to be written with a 1 to clear it before the next SMI can be generated.
- 7 **LID Triggering Polarity**
  - 0 Rising Edge .....default
  - 1 Falling Edge
- 6 **THRM# Triggering Polarity**
  - 0 Rising Edge .....default
  - 1 Falling Edge
- 5 **Battery Low Resume Disable**
  - 0 Enable resume .....default
  - 1 Disable resume from suspend when BATLOW# is asserted
- 4 **SMI Lock (SMIIG)**
  - 0 Disable SMI Lock
  - 1 Enable SMI Lock (SMI low to gate for the next SMI) .....default
- 3 **Wait for Halt / Stop Grant Cycle for CPUTP# Assertion**
  - 0 Don't wait.....default
  - 1 Wait

This bit works with Rx4C[7] of PCI configuration space to control the start of CPUTP# assertion.
- 2 **Power Button Triggering Select**
  - 0 SCI/SMI generated by PWRBTN# rising edge .....default
  - 1 SCI/SMI generated by PWRBTN# low level

Set to zero to avoid the situation where PB\_STS is set to wake up the system then reset again by PBOR\_STS to switch the system into the soft-off state.
- 1 **BIOS Release (BIOS\_RLS)**

This bit is set by legacy software to indicate release of the SCI/SMI lock. Upon setting of this bit, hardware automatically sets the GBL\_STS bit. This bit is cleared by hardware when the GBL\_STS bit cleared by software.

Note that if the GBL\_EN bit is set (bit-5 of the Power Management Enable register at offset 2), then setting this bit causes an SCI to be generated (because setting this bit causes the GBL\_STS bit to be set).
- 0 **SMI Enable (SMI\_EN)**
  - 0 Disable all SMI generation.....default
  - 1 Enable SMI generation

**I/O Offset 2F - SMI Command (SMI\_CMD) ..... RW**

- 7-0 **SMI Command**

Writing to this port sets the SW\_SMI\_STS bit. Note that if the SW\_SMI\_EN bit is set (see bit-6 of the Global Enable register at offset 2Ah), then an SMI is generated.



**I/O Offset 33-30 - Primary Activity Detect Status.....RWC**

These bits correspond to the Primary Activity Detect Enable bits in offset 37-34. All bits default to 0, are set by hardware only, and may only be cleared by writing 1s to the desired bit.

- 31-11 Reserved** .....always read 0
- 10 Audio Access Status** ..... (AUD\_STS)  
Set if Audio is accessed.
- 9 Keyboard Controller Access Status..... (KBC\_STS)**  
Set if the KBC is accessed via I/O port 60h.
- 8 VGA Access Status.....(VGA\_STS)**  
Set if the VGA port is accessed via I/O ports 3B0-3DFh or memory space A0000-BFFFFh.
- 7 Parallel Port Access Status..... (LPT\_STS)**  
Set if the parallel port is accessed via I/O ports 278-27Fh or 378-37Fh (LPT2 or LPT1).
- 6 Serial Port B Access Status ..... (COMB\_STS)**  
Set if the serial port is accessed via I/O ports 2F8-2FFh or 2E8-2Efh (COM2 and COM4 respectively).
- 5 Serial Port A Access Status ..... (COMA\_STS)**  
Set if the serial port is accessed via I/O ports 3F8-3FFh or 3E8-3Efh (COM1 and COM3, respectively).
- 4 Floppy Access Status.....(FDC\_STS)**  
Set if the floppy controller is accessed via I/O ports 3F0-3F5h or 3F7h.
- 3 Secondary IDE Access Status.....(SIDE\_STS)**  
Set if the IDE controller is accessed via I/O ports 170-177h or 376h.
- 2 Primary IDE Access Status ..... (PIDE\_STS)**  
Set if the IDE controller is accessed via I/O ports 1F0-1F7h or 3F6h.
- 1 Primary Interrupt Activity Status.....(PIRQ\_STS)**  
Set on the occurrence of a primary interrupt (enabled via the "Primary Interrupt Channel" register at Function 4 PCI configuration register offset 44h).
- 0 PCI Master Access Status ..... (DRQ\_STS)**  
Set on the occurrence of PCI master activity.

Note: The bits above correspond to the bits of the Primary Activity Detect Enable register at offset 34 (see right hand column of this page): if the corresponding bit is set in that register, setting of the above bits will cause the PACT\_STS bit to be set (bit-0 of the Global Status register at offset 28). Setting of PACT\_STS may be set up to enable a "Primary Activity Event": an SMI will be generated if PACT\_EN is set (bit-0 of the Global Enable register at offset 2Ah) and/or the GP0 timer will be reloaded if the "GP0 Timer Reload on Primary Activity" bit is set (bit-0 of the GP Timer Reload Enable register at offset 38 on this page).

Note: Bits 2-9 above also correspond to bits of the GP Timer Reload Enable register (see offset 38 on next page): If bits are set in that register, setting a corresponding bit in this register will cause the GP1 timer to be reloaded.

**I/O Offset 37-34 - Primary Activity Detect Enable..... RW**

These bits correspond to the Primary Activity Detect Status bits in offset 33-30. Setting of any of these bits also sets the PACT\_STS bit (bit-0 of offset 28) which causes the GP0 timer to be reloaded (if PACT\_GP0\_EN is set) or generates an SMI (if PACT\_EN is set).

- 31-11 Reserved** ..... always read 0
- 10 SMI on Audio Status** ..... (KBC\_EN)  
0 Don't set PACT\_STS if AUD\_STS is set .... def  
1 Set PACT\_STS if AUD\_STS is set
- 9 SMI on Keyboard Controller Status..... (KBC\_EN)**  
0 Don't set PACT\_STS if KBC\_STS is set..... def  
1 Set PACT\_STS if KBC\_STS is set
- 8 SMI on VGA Status..... (VGA\_EN)**  
0 Don't set PACT\_STS if VGA\_STS is set .... def  
1 Set PACT\_STS if VGA\_STS is set
- 7 SMI on Parallel Port Status..... (LPT\_EN)**  
0 Don't set PACT\_STS if LPT\_STS is set..... def  
1 Set PACT\_STS if LPT\_STS is set
- 6 SMI on Serial Port B Status .....(COMB\_EN)**  
0 Don't set PACT\_STS if COMB\_STS is set . def  
1 Set PACT\_STS if COMB\_STS is set
- 5 SMI on Serial Port A Status ..... (COMA\_EN)**  
0 Don't set PACT\_STS if COMA\_STS is set. def  
1 Set PACT\_STS if COMA\_STS is set
- 4 SMI on Floppy Status .....(FDC\_EN)**  
0 Don't set PACT\_STS if FDC\_STS is set ..... def  
1 Set PACT\_STS if FDC\_STS is set
- 3 SMI on Secondary IDE Status.....(SIDE\_EN)**  
0 Don't set PACT\_STS if SIDE\_STS is set.... def  
1 Set PACT\_STS if SIDE\_STS is set
- 2 SMI on Primary IDE Status .....(PIDE\_EN)**  
0 Don't set PACT\_STS if PIDE\_STS is set.... def  
1 Set PACT\_STS if PIDE\_STS is set
- 1 SMI on Primary INTR Status ..... (PIRQ\_EN)**  
0 Don't set PACT\_STS if PIRQ\_STS is set.... def  
1 Set PACT\_STS if PIRQ\_STS is set
- 0 SMI on PCI Master Status ..... (DRQ\_EN)**  
0 Don't set PACT\_STS if DRQ\_STS is set .... def  
1 Set PACT\_STS if DRQ\_STS is set



**I/O Offset 3B-38 - GP Timer Reload Enable .....RW**

All bits in this register default to 0 on power up.

- 31-8 Reserved** .....always read 0
- 7 GP1 Timer Reload on KBC Access**
  - 0 Normal GP1 Timer Operation.....default
  - 1 Setting of KBC\_STS causes the GP1 timer to reload.
- 6 GP1 Timer Reload on Serial Port Access**
  - 0 Normal GP1 Timer Operation .....default
  - 1 Setting of COMA\_STS or COMB\_STS causes the GP1 timer to reload.
- 5 Reserved** .....always read 0
- 4 GP1 Timer Reload on VGA Access**
  - 0 Normal GP1 Timer Operation .....default
  - 1 Setting of VGA\_STS causes the GP1 timer to reload.
- 3 GP1 Timer Reload on IDE/Floppy Access**
  - 0 Normal GP1 Timer Operation .....default
  - 1 Setting of FDC\_STS, SIDE\_STS, or PIDE\_STS causes the GP1 timer to reload.
- 2 GP3 Timer Reload on GPIO Range 1 Access**
  - 0 Normal GP3 Timer Operation .....default
  - 1 Setting of GR1\_STS causes the GP3 timer to reload.
- 1 GP2 Timer Reload on GPIO Range 0 Access**
  - 0 Normal GP2 Timer Operation .....default
  - 1 Setting of GR0\_STS causes the GP2 timer to reload.
- 0 GP0 Timer Reload on Primary Activity**
  - 0 Normal GP0 Timer Operation .....default
  - 1 Setting of PACT\_STS causes the GP0 timer to reload. Primary activities are enabled via the Primary Activity Detect Enable register (offset 37-34) with status recorded in the Primary Activity Detect Status register (offset 33-30).

**I/O Offset 40 – Extended I/O Trap Status (CF/CG)... RWC**

- 7-2 Reserved** ..... always read 0
- 1 GPIO Range 3 Access Status..... (GPR3\_STS)**
- 0 GPIO Range 2 Access Status..... (GPR2\_STS)**

**I/O Offset 42 – Extended I/O Trap Enable (CF/CG).... RW**

- 7-2 Reserved** ..... always read 0
- 1 SMI on GPIO Range 3 Access.....(GPR3\_EN)**
  - 0 Disable..... default
  - 1 Enable
- 0 SMI on GPIO Range 2 Access.....(GPR2\_EN)**
  - 0 Disable..... default
  - 1 Enable

**General Purpose I/O Registers**

**I/O Offset 44 – External SMI / GPI Input Value.....RO**

Depending on the configuration, up to 8 external SCI/SMI ports are available as indicated below. The state of these inputs may be read in this register.

- 7 RING# Input Value..... (GPI7 pin)
- 6 SMBALRT# Input Value ..... (GPI6 pin)
- 5 PME# Input Value ..... (GPI5 pin)
- 4 SLPBTN# Input Value..... (GPI4 pin)
  
- 3 LID Input Value (CD/CE)..... (GPI3 pin)
- 2 BATLOW# Input Value (CD/CE) ..... (GPI2 pin)
  
- 3 General Purpose In 17 Value (CF/CG) (GPI17 pin)
- 2 General Purpose In 16 Value (CF/CG) (GPI16 pin)
  
- 1 General Purpose Input 1 Value ..... (GPI1 pin)
- 0 EXTSMI# Input Value

**I/O Offset 45 – SMI / IRQ / Resume Status .....RO**

- 7-5 Reserved ..... always reads 0
- 4 Latest PCSn Status
  - 0 Latest PCSn was an I/O Read
  - 1 Latest PCSn was an I/O Write
- 3 FM SMI or Serial SMI Status
- 2 Hardware Monitor IRQ Status
- 1 SMBus IRQ Status
- 0 SMBus Resume Status

**I/O Offset 4B-48 - GPI Port Input Value (GPIVAL)..... RO**

- 31-24 Reserved ..... always read 0
- 23-16 GPI[23-16] by Refresh Scan ..... Read Only
- 15-12 Reserved ..... always read 0
- 11-0 GPI[11-0] Input Value ..... Read Only

**I/O Offset 4F-4C - GPO Port Output Value (GPOVAL)RW**

Reads from this register return the last value written (held on chip)

- 31-26 Reserved ..... always reads 0
- 25-0 GPO[25-0] Output Value .....def = 3FFFFFFh

**System Management Bus I/O-Space Registers**

The base address for these registers is defined in Rx93-90 of the Function 4 PCI configuration registers. The System Management Bus I/O space is enabled for access by the system if RxD2[0] = 1.

**I/O Offset 00 – SMBus Host Status.....RWC**

- 7-5 **Reserved** ..... always reads 0
- 4 **Failed Bus Transaction.....RWC**
  - 0 SMBus interrupt not caused by failed bus transaction .....default
  - 1 SMBus interrupt caused by failed bus transaction. This bit may be set when the KILL bit (I/O Rx02[1]) is set and can be cleared by writing a 1 to this bit position.
- 3 **Bus Collision.....RWC**
  - 0 SMBus interrupt not caused by transaction collision.....default
  - 1 SMBus interrupt caused by transaction collision. This bit is only set by hardware and can be cleared by writing a 1 to this bit position.
- 2 **Device Error.....RWC**
  - 0 SMBus interrupt not caused by generation of an SMBus transaction error.....default
  - 1 SMBus interrupt caused by generation of an SMBus transaction error (illegal command field, unclaimed host-initiated cycle, or host device timeout). This bit is only set by hardware and can be cleared by writing a 1 to this bit position.
- 1 **SMBus Interrupt.....RWC**
  - 0 SMBus interrupt not caused by host command completion.....default
  - 1 SMBus interrupt caused by host command completion. This bit is only set by hardware and can be cleared by writing a 1 to this bit position.
- 0 **Host Busy .....RO**
  - 0 SMBus controller host interface is not processing a command .....default
  - 1 SMBus host controller is busy processing a command. None of the other SMBus registers should be accessed if this bit is set.

**I/O Offset 01h – SMBus Slave Status..... RWC**

- 7-6 **Reserved** ..... always reads 0
- 5 **Alert Status ..... RWC**
  - 0 SMBus interrupt not caused by SMBALERT# signal ..... default
  - 1 SMBus interrupt caused by SMBALERT# signal. This bit will be set only if the Alert Enable bit is set in the SMBus Slave Control Register at I/O Offset R08[3]. This bit is only set by hardware and can be cleared by writing a 1 to this bit position.
- 4 **Shadow 2 Status..... RWC**
  - 0 SMBus interrupt not caused by address match to SMBus Shadow Address Port 2..... default
  - 1 SMBus interrupt or resume event caused by slave cycle address match to SMBus Shadow Address Port 2. This bit is only set by hardware and can be cleared by writing a 1 to this bit position.
- 3 **Shadow 1 Status..... RWC**
  - 0 SMBus interrupt not caused by address match to SMBus Shadow Address Port 1..... default
  - 1 SMBus interrupt or resume event caused by slave cycle address match to SMBus Shadow Address Port 1. This bit is only set by hardware and can be cleared by writing a 1 to this bit position.
- 2 **Slave Status ..... RWC**
  - 0 SMBus interrupt not caused by slave event match ..... default
  - 1 SMBus interrupt or resume event caused by slave cycle event match of the SMBus Slave Command Register at PCI Function 4 Configuration Offset D3h (command match) and the SMBus Slave Event Register at SMBus Base + Offset 0Ah (data event match). This bit is only set by hardware and can be cleared by writing a 1 to this bit position.
- 1 **Reserved** ..... always reads 0
- 0 **Slave Busy ..... RO**
  - 0 SMBus controller slave interface is not processing data ..... default
  - 1 SMBus controller slave interface is busy receiving data. None of the other SMBus registers should be accessed if this bit is set.

**I/O Offset 02h – SMBus Host Control.....RW**

- 7 **Reserved** ..... always reads 0
- 6 **Start** ..... always reads 0
  - 0 Writing 0 has no effect .....default
  - 1 **Start Execution of Command**  
Writing a 1 to this bit causes the SMBus controller host interface to initiate execution of the command programmed in the SMBus Command Protocol field (bits 4-2). All necessary registers should be programmed prior to writing a 1 to this bit. The Host Busy bit (SMBus Host Status Register bit-0) can be used to identify when the SMBus controller has completed command execution.
- 5 **Reserved** ..... always reads 0
- 4-2 **SMBus Command Protocol**
  - 000 Quick Read or Write .....default
  - 001 Byte Read or Write
  - 010 Byte Data Read or Write
  - 011 Word Data Read or Write
  - 100 Reserved
  - 101 Block Read or Write
  - 110 Reserved
  - 111 Reserved
- 1 **Kill Transaction in Progress**
  - 0 Normal host controller operation .....default
  - 1 **Stop host transaction currently in progress.**  
Setting this bit also sets the FAILED status bit (Host Status bit-4) and asserts the interrupt selected by the SMB Interrupt Select bit (Function 4 SMBus Host Configuration Register RxD2[3]).
- 0 **Interrupt Enable**
  - 0 Disable interrupt generation .....default
  - 1 Enable generation of interrupts on completion of the current host transaction.

**I/O Offset 03h – SMBus Host Command..... RW**

- 7-0 **SMBUS Host Command** ..... default = 0  
This field contains the data transmitted in the command field of the SMBus host transaction.

**I/O Offset 04h – SMBus Host Address..... RW**

- The contents of this register are transmitted in the address field of the SMBus host transaction.
- 7-1 **SMBUS Address** ..... default = 0  
This field contains the 7-bit address of the targeted slave device.
  - 0 **SMBUS Read or Write**
    - 0 Execute a WRITE command ..... default
    - 1 Execute a READ command

**I/O Offset 05h – SMBus Host Data 0..... RW**

- The contents of this register are transmitted in the Data 0 field of SMBus host transaction writes. On reads, Data 0 bytes are stored here.
- 7-0 **SMBUS Data 0** ..... default = 0  
For Block Write commands, this field is programmed with the block transfer count (a value between 1 and 32). Counts of 0 or greater than 32 are undefined. For Block Read commands, the count received from the SMBus device is stored here.

**I/O Offset 06h – SMBus Host Data 1..... RW**

- The contents of this register are transmitted in the Data 1 field of SMBus host transaction writes. On reads, Data 1 bytes are stored here.
- 7-0 **SMBUS Data 1** ..... default = 0

**I/O Offset 07h – SMBus Block Data ..... RW**

- Reads and writes to this register are used to access the 32-byte block data storage array. An internal index pointer is used to address the array. It is reset to 0 by reads of the SMBus Host Control register (I/O Offset 2) and incremented automatically by each access to this register. The transfer of block data into (read) or out of (write) this storage array during an SMBus transaction always starts at index address 0.
- 7-0 **SMBUS Block Data** ..... default = 0

**I/O Offset 08h – SMBus Slave Control.....RW**

- 7-4 **Reserved** ..... always reads 0
- 3 **SMBus Alert Enable**
  - 0 Disable .....default
  - 1 Enable generation of an interrupt or resume event on the assertion of the SMBALERT# signal
- 2 **SMBus Shadow Port 2 Enable**
  - 0 Disable .....default
  - 1 Enable generation of an interrupt or resume event on external SMBus master generation of a transaction with an address that matches the SMBus Slave Shadow Port 2 register (PCI function 4 configuration register RxD5).
- 1 **SMBus Shadow Port 1 Enable**
  - 0 Disable .....default
  - 1 Enable generation of an interrupt or resume event on external SMBus master generation of a transaction with an address that matches the SMBus Slave Shadow Port 1 register (PCI function 4 configuration register RxD4).
- 0 **SMBus Slave Enable**
  - 0 Disable .....default
  - 1 Enable generation of an interrupt or resume event on external SMBus master generation of a transaction with an address that matches the SMBus host controller slave port of 10h, a command field which matches the SMBus Slave Command register (PCI function 4 configuration register RxD3), and a match of one of the corresponding enabled events in the SMBus Slave Event Register (I/O Offset 0Ah).

**I/O Offset 09h – SMBus Shadow Command ..... RO**

This register is used to store command values for external SMBus master accesses to the host slave and slave shadow ports.

- 7-0 **Shadow Command**..... default = 0  
This field contains the command value which was received during an external SMBus master access whose address field matched the host slave address (10h) or one of the slave shadow port addresses.

**I/O Offset 0Ah – SMBus Slave Event ..... RW**

This register is used to enable generation of interrupt or resume events for accesses to the host controller’s slave port.

- 15-0 **SMBus Slave Event** ..... default = 0  
This field contains data bits used to compare against incoming data to the SMBus Slave Data Register (I/O Offset 0Ch). When a bit in this register is set and the corresponding bit the Slave Data register is also set, an interrupt or resume event will be generated if the command value matches the value in the SMBus Slave Command register and the access was to SMBus host address 10h.

**I/O Offset 0Ch – SMBus Slave Data ..... RO**

This register is used to store data values for external SMBus master accesses to the shadow ports or the SMBus host controller’s slave port.

- 15-0 **SMBus Slave Data** ..... default = 0  
This field contains the data value which was transmitted during an external SMBus master access whose address field matched one of the slave shadow port addresses or the SMBus host controller slave port address of 10h.

**Hardware Monitor I/O Space Registers**

The I/O base address for access to the Hardware Monitor registers is defined in Rx71-70 of function 4 PCI configuration space. The hardware monitor I/O space is enabled for I/O access by the system if Rx74[0] = 1.

**Offset 13 – Analog Data 15-8 .....RW**

**Offset 14 – Analog Data 7-0 .....RW**

**Offset 15 – Digital Data 7-0 .....RW**

**Offset 16 – Channel Counter .....RW**

**Offset 17 – Data Valid & Channel Indicators .....RW**

**Offset 1D – TSENS3 Hot Temperature High Limit .....RW**

**Offset 1E – TSENS3 Hot Temp Hysteresis Lo Limit .....RW**

**Offset 1F – TSENS3 Temperature Reading .....RW**

Temperature sensor 3 is an internal bandgap-type sensor which has 10-bit resolution. The high order 8 bits are stored here and the low order 2 bits are stored in Rx49[7-6]. Only the high order 8 bits are used for comparison with the limit values in offsets 1D and 1E.

**Offset 20 – TSENS1 Temperature Reading .....RW**

Temperature sensor 1 is an external sensor input on pin W13 which has 10-bit resolution. The high order 8 bits are stored here and the low order 2 bits are stored in Rx4B[7-6]. Only the high order 8 bits are used for comparison with the limit values in offsets 39 and 3A.

**Offset 21 – TSENS2 Temperature Reading .....RW**

Temperature sensor 2 is an external sensor input on pin Y13 which has 10-bit resolution. The high order 8 bits are stored here and the low order 2 bits are stored in Rx49[5-4]. Only the high order 8 bits are used for comparison with the limit values in offsets 3D and 3E.

**Offset 22 – VSENS1 (Pin U13) Voltage Reading (2.0V)..RW**

**Offset 23 – VSENS2 (Pin V13) Voltage Reading (2.5V)..RW**

**Offset 24 – Internal Core Voltage Reading (3.3V) .....RW**

**Offset 25 – VSENS3 (Pin W14) Voltage Reading (5V) ..RW**

**Offset 26 – VSENS4 (Pin Y14) Voltage Reading (12V)..RW**

**Offset 27 – Reserved (-12V Sense Voltage Reading) .....RW**

**Offset 28 – Reserved (-5V Sense Voltage Reading) .....RW**

**Offset 29 – FAN1 (Pin T12) Count Reading ..... RW**

**Offset 2A – FAN2 (Pin U12) Count Reading ..... RW**

The above two locations store the number of counts of the internal clock per fan revolution.

**Offset 2B – VSENS1 Voltage High Limit (CPU 2.0V)... RW**

**Offset 2C – VSENS1 Voltage Low Limit (CPU 2.0V) ... RW**

**Offset 2D – VSENS2 Voltage High Limit (NB 2.5V) ..... RW**

**Offset 2E – VSENS2 Voltage Low Limit (NB 2.5V) ..... RW**

**Offset 2F – Internal Core Voltage High Limit (3.3V).... RW**

**Offset 30 – Internal Core Voltage Low Limit (3.3V)..... RW**

**Offset 31 – VSENS3 Voltage High Limit (5V)..... RW**

**Offset 32 – VSENS3 Voltage Low Limit (5V) ..... RW**

**Offset 33 – VSENS4 Voltage High Limit (12V)..... RW**

**Offset 34 – VSENS4 Voltage Low Limit (12V) ..... RW**

**Offset 35 – Reserved (-12V Sense High Limit) ..... RW**

**Offset 36 – Reserved (-12V Sense Low Limit)..... RW**

**Offset 37 – Reserved (-5V Sense High Limit) ..... RW**

**Offset 38 – Reserved (-5V Sense Low Limit)..... RW**

**Offset 39 – TSENS1 Hot Temperature High Limit ..... RW**

**Offset 3A – TSENS1 Hot Temp Hysteresis Lo Limit ..... RW**

**Offset 3B – FAN1 Fan Count Limit ..... RW**

**Offset 3C – FAN2 Fan Count Limit ..... RW**

The above two locations store the number of counts of the internal clock per fan revolution for the low limit of the fan speed.

**Offset 3D – TSENS2 Hot Temperature High Limit ..... RW**

**Offset 3E – TSENS2 Hot Temp Hysteresis Lo Limit ..... RW**

**Offset 3F – Stepping ID Number ..... RW**

Note: For high limits, comparisons are “greater than” comparisons. For low limits, comparisons are “less than or equal” comparisons.

One consequence of the above is that if high limits are set to all ones (FFh or 11111111b), interrupts are disabled for high limits (i.e., interrupts will only be generated for cases when voltages are equal to or below the low limits).

**Offset 40 –Hardware Monitor Configuration .....RW**

**7 Initialization**

- 0 Normal operation .....default
- 1 Restore power-up default values to this register, the interrupt status and mask registers, the FAN/RST#/OS# register, and the OS# Configuration / Temperature Resolution register. This bit automatically clears itself since the power-on default is 0.

**6 Chassis Intrusion Reset**

- 0 Normal operation .....default
- 1 Reset the Chassis Intrusion pin

**5-4 Reserved (R/W)..... default = 0**

**3 Hardware Monitor Interrupt Clear**

- 0 Normal operation
- 1 Clear the hardware monitor interrupt output (does not effect the contents of the interrupt status register). Normally set during interrupt service .....default

**2 Reserved ..... always reads 0**

**1 Hardware Monitor Interrupt Enable**

- 0 Disable hardware monitor interrupt output.. def
- 1 Enable hardware monitor interrupt output

**0 Start**

- 0 Place hardware monitor in standby mode.... def
- 1 Enable startup of hardware monitor logic.  
At startup, limit checking functions and scanning begins. All high and low limits should be set prior to turning on this bit. Note: the hardware monitor interrupt output will not be cleared if the user writes a zero to this bit after an interrupt has occurred (the hardware monitor interrupt clear bit must be used for this purpose).



**Offset 41 –Hardware Monitor Interrupt Status 1.....RO**

- 7 **Fan 2 Error**
  - 0 No error.....default
  - 1 Fan 2 count limit exceeded
- 6 **Fan 1 Error**
  - 0 No error.....default
  - 1 Fan 1 count limit exceeded
- 5 **Reserved** ..... always reads 0
- 4 **TSENS1 Temperature Error**
  - 0 No error.....default
  - 1 High or low hot temperature limit exceeded. The interrupt mode is determined by Temperature Resolution register Rx4B[1-0].
- 3 **VSENS3 Voltage Error (5V)**
  - 0 No error.....default
  - 1 High or low limit exceeded
- 2 **Internal Core VCC Voltage Error (3.3V)**
  - 0 No error.....default
  - 1 High or low limit exceeded
- 1 **VSENS2 Voltage Error (2.5V NB Core Voltage)**
  - 0 No error.....default
  - 1 High or low limit exceeded
- 0 **VSENS1 Voltage Error (2.0V CPU Core Voltage)**
  - 0 No error.....default
  - 1 High or low limit exceeded

**Offset 42 –Hardware Monitor Interrupt Status 2.....RO**

- 7 **TSENS3 (Internal Bandgap) Temp Error**
  - 0 No error.....default
  - 1 High or low hot temperature limit exceeded. Interrupt mode is determined by Rx4B[5-4].
- 6-5 **Reserved** ..... always reads 0
- 4 **Chassis Error**
  - 0 No error.....default
  - 1 Chassis Intrusion has gone high
- 3 **TSENS2 Temperature Error**
  - 0 No error.....default
  - 1 High or low hot temperature limit exceeded. Interrupt mode is determined by Rx4B[3-2].
- 2-1 **Reserved** ..... always reads 0
- 0 **VSENS4 Voltage Error (12V)**
  - 0 No error.....default
  - 1 High or low limit exceeded

Note: When either status register is read, status conditions in that register are reset. In the case of voltage priority indications, if two or more voltages were out of limits, then another indication would automatically be generated if it was not handled during interrupt service. Errant voltages may be disabled in the control register until the operator has time to clear the errant condition or set the limit higher or lower.

**Offset 43 –Hardware Monitor Interrupt Mask 1 ..... RW**

- 7 **Fan 2 Count Error Mask**
  - 0 Enable interrupt on error status bit set ..... def
  - 1 Disable interrupt on error status bit set
- 6 **Fan 1 Count Error Mask**
  - 0 Enable interrupt on error status bit set ..... def
  - 1 Disable interrupt on error status bit set
- 5 **TSENS1 Thermal Alarm Control Mask**
  - 0 Enable TSENS1 over-temp condition to control the thermal alarm (function 4 Rx40[7] automatic CPU clock throttling must be set) def
  - 1 Disable
- 4 **TSENS1 Temperature Error Mask**
  - 0 Enable interrupt on error status bit set ..... def
  - 1 Disable interrupt on error status bit set
- 3 **VSENS3 Voltage Error Mask (5V)**
  - 0 Enable interrupt on error status bit set ..... def
  - 1 Disable interrupt on error status bit set
- 2 **Internal Core VCC Voltage Error Mask (3.3V)**
  - 0 Enable interrupt on error status bit set ..... def
  - 1 Disable interrupt on error status bit set
- 1 **VSENS2 Voltage Error Mask (2.5V NB Core)**
  - 0 Enable interrupt on error status bit set ..... def
  - 1 Disable interrupt on error status bit set
- 0 **VSENS1 Voltage Error Mask (2.0V CPU Core)**
  - 0 Enable interrupt on error status bit set ..... def
  - 1 Disable interrupt on error status bit set

**Offset 44 –Hardware Monitor Interrupt Mask 2 ..... RW**

- 7 **TSENS3 Temperature Error Mask**
  - 0 Enable interrupt on error status bit set ..... def
  - 1 Disable interrupt on error status bit set
- 6 **TSENS3 Thermal Alarm Control Mask**
  - 0 Enable TSENS3 over-temp condition to control the thermal alarm (function 4 Rx40[7] automatic CPU clock throttling must be set) def
  - 1 Disable
- 5 **TSENS2 Thermal Alarm Control Mask**
  - 0 Enable TSENS2 over-temp condition to control the thermal alarm (function 4 Rx40[7] automatic CPU clock throttling must be set) def
  - 1 Disable
- 4 **Chassis Error Mask**
  - 0 Enable interrupt on error status bit set ..... def
  - 1 Disable interrupt on error status bit set
- 3 **TSENS2 Temperature Error Mask**
  - 0 Enable interrupt on error status bit set ..... def
  - 1 Disable interrupt on error status bit set
- 2-1 **Reserved** ..... always reads 0
- 0 **VSENS4 Voltage Error Mask (12V)**
  - 0 Enable interrupt on error status bit set ..... def
  - 1 Disable interrupt on error status bit set

**Offset 47 –Hardware Monitor Fan Configuration.....RW**

- 7-6 Fan 2 RPM Control**
  - 00 Divide by 1
  - 01 Divide by 2 .....default
  - 10 Divide by 4
  - 11 Divide by 8
- 5-4 Fan 1 RPM Control**
  - 00 Divide by 1
  - 01 Divide by 2 .....default
  - 10 Divide by 4
  - 11 Divide by 8
- 3-0 Reserved** ..... always reads 0

**Offset 49 –Hardware Monitor Temp Low Order ValueRW**

- 7-6 TSENS3 Value Low-Order Bits**  
Upper 8 bits are stored in offset 1Fh
- 5-4 TSENS2 Value Low-Order Bits**  
Upper 8 bits are stored in offset 21h
- 3 Over Temperature Active Low for PMU to Control Stop Clock**
  - 0 Disable .....default
  - 1 Enable
- 2 Chassis Active Low Output 20 msec**
  - 0 Disable .....default
  - 1 Enable
- 1 Interrupt Active High Output**
  - 0 Disable .....default
  - 1 Enable
- 0 Reserved** ..... always reads 0

**Offset 4B –Temperature Interrupt Configuration ..... RW**

- 7-6 TSENS1 Value Low-Order Bits** .....def = 00  
Upper 8 bits are stored in offset 20h
  - 5-4 TSENS3 Hot Temp Interrupt Mode** .....def = 01
  - 3-2 TSENS2 Hot Temp Interrupt Mode** .....def = 01
  - 1-0 TSENS1 Hot Temp Interrupt Mode** .....def = 01
- The following applies to each of the above 3 fields
- 00 Default Interrupt Mode. An interrupt occurs if the temperature goes above the hot limit. The interrupt will be cleared once the status register is read, but will be generated again when the next conversion is completed. Interrupts will continue to be generated until the temperature goes below the hysteresis limit.
  - 01 One-Time Interrupt Mode. An interrupt is generated if the temperature goes above the hot limit. The interrupt will be cleared when the status register is read. Another interrupt will not be generated until the temperature first drops below the hysteresis limit. .... default
  - 10 Comparator mode. An interrupt occurs if the temperature goes above the hot limit. This interrupt remains active until the temperature goes below the hot limit (i.e., no hysteresis).
  - 11 Default Interrupt Mode (same as 00)

**Function 5 & 6 Registers - AC97 Audio & Modem Codecs**

The codec interface is hardware compatible with AC97 and SoundBlaster Pro. There are two sets of software accessible registers: PCI configuration registers and I/O registers. The PCI configuration registers for the **Audio Codec** are located in the **function 5** PCI configuration space of the VT82C686A. The PCI configuration registers for the **Modem Codec** are located in the **function 6** PCI configuration space. The I/O registers are located in the system I/O space.

**PCI Configuration Space Header – Function 5 Audio**

**Offset 1-0 - Vendor ID .....RO**

0-7 Vendor ID ..... (1106h = VIA Technologies)

**Offset 3-2 - Device ID.....RO**

0-7 Device ID (3058h = 82C686A Audio Codec)

**Offset 5-4 - Command.....RW**

- 15-10 Reserved ..... always reads 0
- 9 Fast Back-to-Back.....fixed at 0
- 8 SERR# Enable.....fixed at 0
- 7 Address Stepping .....fixed at 0
- 6 Parity Error Response.....fixed at 0
- 5 VGA Palette Snoop .....fixed at 0
- 4 Memory Write and Invalidate .....fixed at 0
- 3 Special Cycle Monitoring .....fixed at 0
- 2 Bus Master .....fixed at 0
- 1 Memory Space.....fixed at 0
- 0 I/O Space ..... default=0 (disabled)

**Offset 7-6 - Status.....RWC**

- 15 Detected Parity Error ..... always reads 0
- 14 Signalled System Error..... default=0
- 13 Received Master Abort.....fixed at 0
- 12 Received Target Abort .....fixed at 0
- 11 Signalled Target Abort.....fixed at 0
- 10-9 DEVSEL# Timing
  - 00 Fast
  - 01 Medium ..... fixed
  - 10 Slow
  - 11 Reserved
- 8 Data Parity Error.....fixed at 0
- 7 Fast Back-to-Back Capable.....fixed at 0
- 6-5 Reserved ..... always reads 0
- 4 PM 1.1 .....fixed at 1
- 3-0 Reserved ..... always reads 0

**Offset 8 - Revision ID (nnh) .....RO**

- 7-0 Silicon Revision Code
  - 10h Revision A
  - 11h Revision B
  - 12h Revision C
  - 13h Revision D
  - 14h Revision E
  - 20h Revision H

**Offset 9 - Programming Interface (00h)..... RO**

**Offset A - Sub Class Code (01h=Audio Device)..... RO**

**Offset B - Base Class Code (04h=Multimedia Device) ..... RO**

**Offset D - Latency Timer (00h)..... RO**

**Offset E - Header Type (00h)..... RO**

**Offset F - BIST (00h) ..... RO**

**Offset 13-10 - Base Address 0 – SGD Control / Status.. RW**

- 31-16 Reserved ..... always reads 0
- 15-8 Base Address ..... default = 00h
- 7-0 00000001b (256 bytes)

**Offset 17-14 - Base Address 1 – FM NMI Status ..... RW**

- 31-16 Reserved ..... always reads 0
- 15-2 Base Address ..... default = 0000h
- 1-0 01b (4 bytes)

**Offset 1B-18 - Base Address 2 – MIDI Port (CF/CG) ... RW**

- 31-16 Reserved ..... always reads 0
- 15-2 Base Address ..... default = 0330h
- 1-0 01b (4 bytes)

**Offset 2F-2C – Subsystem ID / Sub Vendor ID (CF/CG)RO\***

\*This register is RW if function 5-6 Rx42[5] = 1

**Offset 34 – Capture Pointer (CF/CG) (Def=C0h) ..... RO**

**Offset 3C - Interrupt Line..... RW**

- 7-4 Reserved ..... always reads 0
- 3-0 Audio Interrupt Routing
  - 0000 Disable ..... default
  - 0001 IRQ1
  - 0010 Reserved
  - 0011 IRQ3
  - 0100 IRQ4
  - 0101 IRQ5
  - 0110 IRQ6
  - 0111 IRQ7
  - 1000 IRQ8
  - 1001 IRQ9
  - 1010 IRQ10
  - 1011 IRQ11
  - 1100 IRQ12
  - 1101 IRQ13
  - 1110 IRQ14
  - 1111 Disable

**Offset 3D - Interrupt Pin (03h)..... RO**

**Offset 3E - Minimum Grant (00h)..... RO**

**Offset 3F - Minimum Latency (00h)..... RO**

**PCI Configuration Space Header – Function 6 Modem**

**Offset 1-0 - Vendor ID .....RO**

0-7 Vendor ID ..... (1106h = VIA Technologies)

**Offset 3-2 - Device ID.....RO**

0-7 Device ID (3068h = 82C686A Modem Codec)

**Offset 5-4 - Command.....RW**

- 15-10 Reserved ..... always reads 0
- 9 Fast Back-to-Back.....fixed at 0
- 8 SERR# Enable.....fixed at 0
- 7 Address Stepping .....fixed at 0
- 6 Parity Error Response.....fixed at 0
- 5 VGA Palette Snoop .....fixed at 0
- 4 Memory Write and Invalidate .....fixed at 0
- 3 Special Cycle Monitoring .....fixed at 0
- 2 Bus Master .....fixed at 0
- 1 Memory Space.....fixed at 0
- 0 I/O Space ..... default=0 (disabled)

**Offset 7-6 - Status.....RWC**

- 15 Detected Parity Error..... always reads 0
- 14 Signalled System Error.....fixed at 0
- 13 Received Master Abort.....fixed at 0
- 12 Received Target Abort .....fixed at 0
- 11 Signalled Target Abort.....fixed at 0
- 10-9 DEVSEL# Timing
  - 00 Fast
  - 01 Medium ..... fixed
  - 10 Slow
  - 11 Reserved
- 8 Data Parity Error.....fixed at 0
- 7 Fast Back-to-Back Capable.....fixed at 0
- 6-0 Reserved ..... always reads 0

**Offset 8 - Revision ID (nnh) .....RO**

7-0 Silicon Revision Code (0 indicates first silicon)

**Offset 9 - Programming Interface (00h).....\*RO**

**Offset A - Sub Class Code (80h).....\*RO**

**Offset B - Base Class Code (07h).....\*RO**

\*Registers 9-B are RW if function 5-6 Rx44[5] = 1

**Offset D - Latency Timer (00h) .....RO**

**Offset E - Header Type (00h) .....RO**

**Offset F - BIST (00h).....RO**

**Offset 13-10 - Base Address 0 – SGD Control / Status.. RW**

31-16 Reserved .....always reads 0

15-8 Base Address..... default = 00h

7-0 00000001b (256 bytes)

**Offset 3C - Interrupt Line..... RW**

7-4 Reserved .....always reads 0

**3-0 Audio Interrupt Routing**

- 0000 Disable..... default
- 0001 IRQ1
- 0010 Reserved
- 0011 IRQ3
- 0100 IRQ4
- 0101 IRQ5
- 0110 IRQ6
- 0111 IRQ7
- 1000 IRQ8
- 1001 IRQ9
- 1010 IRQ10
- 1011 IRQ11
- 1100 IRQ12
- 1101 IRQ13
- 1110 IRQ14
- 1111 Disable

**Offset 3D - Interrupt Pin (03h)..... RO**

**Offset 3E - Minimum Grant (00h)..... RO**

**Offset 3F - Minimum Latency (00h)..... RO**

**Function 5 & 6 Codec-Specific Configuration Registers**

**Offset 40 – AC97 Interface Status .....RO**

- 7-3 **Reserved** ..... always reads 0
- 2 **Secondary Codec Ready Status** .....RO
  - 0 Codec Not Ready
  - 1 Codec Ready (AC97 ctrlr can access codec)
- 1 **AC97 Codec Low-Power Status**.....RO
  - 0 AC97 Codec not in low-power mode
  - 1 AC97 Codec in low-power mode
- 0 **AC97 Codec Ready Status**.....RO
  - 0 Codec Not Ready
  - 1 Codec Ready (AC97 ctrlr can access codec)

**Offset 41 – AC Link Interface Control ..... RW**

- 7 **AC-Link Interface Enable (ENAC97)**
  - 0 Disable..... default
  - 1 Enable
- 6 **AC-Link Reset (ACRST#)**
  - 0 Assert AC-Link Reset ..... default
  - 1 De-assert AC-Link Reset
- 5 **AC-Link Sync (RSYNCHI)**
  - 0 Release SYNC ..... default
  - 1 Force SYNC High
- 4 **AC-Link Serial Data Out**
  - 0 Release SDO..... default
  - 1 Force SDO High
- 3 **Variable-Sample-Rate On-Demand Mode**
  - 0 Disable..... default
  - 1 Enable

Bit valid in function 5 only (reserved in function 6)
- 2 **AC Link SGD Read Channel PCM Data Output**
  - 0 Disable..... default
  - 1 Enable

Bit valid in function 5 only (reserved in function 6)
- 1 **AC Link FM Channel PCM Data Out (SELFM)**
  - 0 Disable..... default
  - 1 Enable

Bit valid in function 5 only (reserved in function 6)
- 0 **AC Link SB PCM Data Output (SELSB)**
  - 0 Disable..... default
  - 1 Enable

Bit valid in function 5 only (reserved in function 6)

**Offset 42 – Function Enable .....RW (Function 5)**

**Offset 42 – Function Enable .....RO (Function 6)**

- 7 MIDI PnP (CF/CG Silicon)**
  - 0 MIDI Port Address Selected by Rx43[3-2]. def
  - 1 MIDI Port Address Selected by IOBase2
- 6 Mask MIDI IRQ**
  - 0 Disable .....default
  - 1 Enable
- 5 Function 5 Config Reg Rx2C Writable (CF/CG)**
  - 0 F5Rx2C-2F RO .....default
  - 1 F5Rx2C-2F RW
- 4 Gate SoundBlaster PCM When FIFO Empty**
  - 0 Disable .....default
  - 1 Enable
- 3 Game Port Enable (ENGAME)**
  - 0 Disable .....default
  - 1 Enable (200-207h)
- 2 FM Enable (ENFM)**
  - 0 Disable .....default
  - 1 Enable (388-38B)
- 1 MIDI Enable (ENMIDI)**
  - 0 Disable .....default
  - 1 Enable
- 0 SoundBlaster Enable (ENSB)**
  - 0 Disable .....default
  - 1 Enable

**Offset 43 – Plug and Play Control .....RW (Function 5)**

**Offset 43 – Plug and Play Control .....RO (Function 6)**

- 7-6 SoundBlaster IRQ Select (SBIRQS[1:0])**
  - 00 IRQ5 .....default
  - 01 IRQ7
  - 10 IRQ9
  - 11 IRQ10
- 5-4 SoundBlaster DRQ Select (SBDQRS[1:0])**
  - 00 DMA Channel 0
  - 01 DMA Channel 1 .....default
  - 10 DMA Channel 2
  - 11 DMA Channel 3
- 3-2 MIDI Decode Select (MIDIBASE)**
  - 00 300-303h
  - 01 310-313h
  - 10 320-323h
  - 11 330-333h .....default
- 1-0 SoundBlaster Decode Select (SBBASE)**
  - 00 220-22Fh .....default
  - 01 240-24Fh
  - 10 260-26Fh
  - 11 280-28Fh

**Offset 44 – MC97 Interface Control ..... RO (Function 5)**

**Offset 44 – MC97 Interface Control ..... RW (Function 6)**

- 7 AC-Link Interface for Slot-5**
  - 0 Disable..... default
  - 1 Enable
- 6 Secondary Codec Support**
  - 0 Disable..... default
  - 1 Enable
- 5 Function 6 Config Reg Rx9-B Writable (CF/CG)**
  - 0 F6Rx9-B RO..... default
  - 1 F6Rx9-B RW
- 4 Function 6 Config Reg 2Ch Writable (CF/CG)**
  - 0 F6Rx2C-2F RO..... default
  - 1 F6Rx2C-2F RW
- 3-0 Reserved** .....always reads 0

**Offset 48 – FM NMI Control..... RW (Function 5)**

**Offset 48 – FM NMI Control..... RO (Function 6)**

- 7-3 Reserved** .....always reads 0
- 2 FM IRQ Select**
  - 0 Route FM Trap interrupt to NMI..... default
  - 1 Route FM Trap interrupt to SMI
- 1 FM SGD Data for SoundBlaster Mixing**
  - 0 Disable..... default
  - 1 Enable
- 0 FM Trap Interrupt**
  - 0 Enable
  - 1 Disable ..... default

**Offset 4B-4A – Game Port Base Address (CF/CG) ..... RW**

- 15-0 Game Port Base Address** ..... default = 0

**I/O Base 0 Registers –Audio/Modem Scatter/Gather DMA**

Read / Write through function 5, R/O through function 6.

**I/O Offset 0 – Audio SGD Read Channel Status .....RWC**

- 7 SGD Active (0 = completed or terminated).....RO
- 6 SGD Paused .....RO
- 5-4 Reserved ..... always reads 0
- 3 SGD Trigger Queued (will restart after EOL)..RO
- 2 SGD Stopped (write 1 to resume) .....RWC
- 1 SGD EOL .....RWC
- 0 SGD Flag .....RWC

**I/O Offset 1 – Audio SGD Read Channel Control.....RW**

- 7 SGD Start ..... WO (always reads 0)
  - 0 No effect
  - 1 Start SGD read channel operation
- 6 SGD Terminate ..... WO (always reads 0)
  - 0 No effect
  - 1 Terminate SGD read channel operation
- 5-4 Reserved .....always reads 0, writing 1 not allowed
- 3 SGD Pause
  - 0 Release SGD read channel pause and resume the transfer from the paused line
  - 1 Pause SGD read channel operation (SGD read channel pointer stays at the current address)
- 2-0 Reserved ..... always reads 0

**I/O Offset 2 – Audio SGD Read Channel Type .....RW**

- 7 Auto-Start SGD at EOL (1=Enable) ..... default = 0
- 6 Reserved ..... always reads 0
- 5 PCM 16-Bit Format
  - 0 8-Bit Format .....default
  - 1 16-Bit Format
- 4 PCM Stereo Format
  - 0 Mono Format.....default
  - 1 Stereo Format
- 3-2 Interrupt Select
  - 00 Interrupt at PCI Read of Last Line .....default
  - 01 Interrupt at Last Sample Sent
  - 10 Interrupt at Less Than One Line to Send
  - 11 -reserved-
- 1 Interrupt on EOL @ End of Block (1=Ena)... def=0
- 0 Interrupt on FLAG @ End-of-Blk (1=Ena) ... def=0

**I/O Offset 7-4 – Audio SGD R Ch Table Pointer Base...RW**

- 31-0 SGD Table Pointer Base Address (even addr).... W  
Current Pointer Address .....R

**I/O Offset F-C – Audio SGD R Ch Current Count.....RO**

- 31-24 Reserved ..... always reads 0
- 23-0 Current SGD Read Channel Count

**SGD Table Format**

<u>63</u>	<u>62</u>	<u>61</u>	<u>60-56</u>	<u>55-32</u>	<u>31-0</u>
EOL	FLAG	STOP	-reserved-	Base	Base
				Count	Address
				[23:0]	[31:0]

**I/O Offset 10 – Audio SGD Write Channel Status..... RO**

- 7 SGD Active (0 = completed or terminated) ..... RO
- 6 SGD Paused ..... RO
- 5-4 Reserved .....always reads 0
- 3 SGD Trigger Queued (will restart after EOL)..RO
- 2 SGD Stopped (write 1 to resume)..... RWC
- 1 SGD EOL ..... RWC
- 0 SGD Flag ..... RWC

**I/O Offset 11 – Audio SGD Write Channel Control..... RW**

- 7 SGD Start ..... WO (always reads 0)
  - 0 No effect
  - 1 Start SGD write channel operation
- 6 SGD Terminate ..... WO (always reads 0)
  - 0 No effect
  - 1 Terminate SGD write channel operation
- 5-4 Reserved .....always reads 0, writing 1 not allowed
- 3 SGD Pause
  - 0 Release SGD write channel pause and resume the transfer from the paused line
  - 1 Pause SGD write channel operation (SGD write channel pointer stays at current address)
- 2-0 Reserved ..... always reads 0

**I/O Offset 12 – Audio SGD Write Channel Type..... RW**

- 7 Auto-Start SGD at EOL (1=Enable)..... default = 0
- 6 Recording FIFO (1=Enable)..... default = 0
- 5 PCM 16-Bit Format
  - 0 8-Bit Format ..... default
  - 1 16-Bit Format
- 4 PCM Stereo Format
  - 0 Mono Format ..... default
  - 1 Stereo Format
- 3-2 Reserved .....always reads 0
- 1 Interrupt on EOL @ End of Block (1=Ena) ... def=0
- 0 Interrupt on FLAG @ End-of-Blk (1=Ena).... def=0

**I/O Offset 17-14 – Audio SGD W Ch Table Pointer BaseRW**

- 31-0 SGD Table Pointer Base Address (even addr).... W  
Current Pointer Address ..... R

**I/O Offset 1F-1C – Audio SGD W Ch Current Count ... RO**

- 31-24 Reserved .....always reads 0
- 23-0 Current SGD Write Channel Count

**EOL** End Of Link. 1 indicates this block is the last of the link. If the channel “Interrupt on EOL” bit is set, then an interrupt is generated at the end of the transfer.

**FLAG** Block Flag. If set, transfer pauses at the end of this block. If the channel “Interrupt on FLAG” bit is set, then an interrupt is generated at the end of this block.

**STOP** Block Stop. If set, transfer pauses at the end of this block. To resume the transfer, write 1 to Rx?0[2].



Read / Write through function 5, R/O through function 6.

The following set of registers is dedicated for FM:

**I/O Offset 20 – FM SGD Read Channel Status .....RWC**

- 7 SGD Active (0 = completed or terminated).....RO
- 6 SGD Paused .....RO
- 5-4 Reserved ..... always reads 0
- 3 SGD Trigger Queued (will restart after EOL) ..RO
- 2 SGD Stopped (write 1 to resume) .....RWC
- 1 SGD EOL .....RWC
- 0 SGD Flag .....RWC

**I/O Offset 21 – FM SGD Read Channel Control.....RW**

- 7 SGD Start ..... WO (always reads 0)
  - 0 No effect
  - 1 Start SGD read channel operation
- 6 SGD Terminate ..... WO (always reads 0)
  - 0 No effect
  - 1 Terminate SGD read channel operation
- 5-4 Reserved .....always reads 0, writing 1 not allowed
- 3 SGD Pause .....RW
  - 0 Release SGD read channel pause and resume the transfer from the paused line
  - 1 Pause SGD read channel operation (SGD read channel pointer stays at the current address)
- 2-0 Reserved ..... always reads 0

**I/O Offset 22 – FM SGD Read Channel Type .....RW**

- 7 Auto-Start SGD at EOL (1=Enable) ..... default = 0
- 6-4 Reserved ..... always reads 0
- 3-2 Interrupt Select
  - 00 Interrupt at PCI Read of Last Line .....default
  - 01 Interrupt at Last Sample Sent
  - 10 Interrupt at Less Than One Line to Send
  - 11 -reserved-
- 1 Interrupt on EOL @ End of Block
  - 0 Disable .....default
  - 1 Enable
- 0 Interrupt on FLAG @ End-of-Blk
  - 0 Disable .....default
  - 1 Enable

**I/O Offset 27-24 – FM SGD Rd Ch Table Pointer Base RW**

- 31-0 SGD Table Pointer Base Address (even addr).... W
- Current Pointer Address .....R

**I/O Offset 2F-2C – FM SGD Rd Chan Current Count...RO**

- 31-24 Reserved ..... always reads 0
- 23-0 Current SGD FM Read Channel Count



Read / Write through function 6, R/O through function 5.

**I/O Offset 40 – Modem SGD Read Channel Status.....RWC**

- 7 SGD Active (0 = completed or terminated).....RO
- 6 SGD Paused .....RO
- 5-4 Reserved ..... always reads 0
- 3 SGD Trigger Queued (will restart after EOL)..RO
- 2 SGD Stopped (write 1 to resume) .....RWC
- 1 SGD EOL .....RWC
- 0 SGD Flag .....RWC

**I/O Offset 41 – Modem SGD Read Channel Control.....RW**

- 7 SGD Start ..... WO (always reads 0)
  - 0 No effect
  - 1 Start SGD read channel operation
- 6 SGD Terminate ..... WO (always reads 0)
  - 0 No effect
  - 1 Terminate SGD read channel operation
- 5-4 Test (Do Not Program) ..... always write 0
- 3 SGD Pause .....RW
  - 0 Release SGD read channel pause and resume the transfer from the paused line
  - 1 Pause SGD read channel operation (SGD read channel pointer stays at the current address)
- 2-0 Reserved ..... always reads 0

**I/O Offset 42 – Modem SGD Read Channel Type.....RW**

- 7 Auto-Start SGD at EOL (1=Enable) ..... default = 0
- 6-4 Reserved ..... always reads 0
- 3-2 Interrupt Select
  - 00 Interrupt at PCI Read of Last Line .....default
  - 01 Interrupt at Last Sample Sent
  - 10 Interrupt at Less Than One Line to Send
  - 11 -reserved-
- 1 Interrupt on EOL @ End of Block
  - 0 Disable .....default
  - 1 Enable
- 0 Interrupt on FLAG @ End-of-Blk
  - 0 Disable .....default
  - 1 Enable

**I/O Offset 47-44 – Modem SGD R Ch Table Ptr Base...RW**

- 31-0 SGD Table Pointer Base Address (even addr).... W
- Current Pointer Address .....R

**I/O Offset 4F-4C – Modem SGD R Ch Current Count ..RO**

- 31-24 Reserved ..... always reads 0
- 23-0 Current SGD Read Channel Count

**I/O Offset 50 – Modem SGD Write Channel Status..... RO**

- 7 SGD Active (0 = completed or terminated) ..... RO
- 6 SGD Paused ..... RO
- 5-4 Reserved ..... always reads 0
- 3 SGD Trigger Queued (will restart after EOL).. RO
- 2 SGD Stopped (write 1 to resume)..... RWC
- 1 SGD EOL ..... RWC
- 0 SGD Flag ..... RWC

**I/O Offset 51 – Modem SGD Write Channel Control ... RW**

- 7 SGD Start ..... WO (always reads 0)
  - 0 No effect
  - 1 Start SGD write channel operation
- 6 SGD Terminate ..... WO (always reads 0)
  - 0 No effect
  - 1 Terminate SGD write channel operation
- 5-4 Test (Do Not Program) ..... always write 0
- 3 SGD Pause ..... RW
  - 0 Release SGD write channel pause and resume the transfer from the paused line
  - 1 Pause SGD write channel operation (SGD write channel pointer stays at current address)
- 2-0 Reserved ..... always reads 0

**I/O Offset 52 – Modem SGD Write Channel Type..... RW**

- 7 Auto-Start SGD at EOL (1=Enable)..... default = 0
- 6-2 Reserved ..... always reads 0
- 1 Interrupt on EOL @ End of Block (1=Ena) ...def=0
- 0 Interrupt on FLAG @ End-of-Blk (1=Ena)....def=0

**I/O Offset 57-54 – Modem SGD W Ch Table Ptr Base . RW**

- 31-0 SGD Table Pointer Base Address (even addr).... W
- Current Pointer Address ..... R

**I/O Offset 5F-5C – Modem SGD W Ch Current Count. RO**

- 31-24 Reserved ..... always reads 0
- 23-0 Current SGD Write Channel Count

**EOL** End Of Link. 1 indicates this block is the last of the link. If the channel “Interrupt on EOL” bit is set, then an interrupt is generated at the end of the transfer.

**FLAG** Block Flag. If set, transfer pauses at the end of this block. If the channel “Interrupt on FLAG” bit is set, then an interrupt is generated at the end of this block.

**STOP** Block Stop. If set, transfer pauses at the end of this block. To resume the transfer, write 1 to Rx?0[2].

**SGD Table Format**

<b><u>63</u></b>	<b><u>62</u></b>	<b><u>61</u></b>	<b><u>60-56</u></b>	<b><u>55-32</u></b>	<b><u>31-0</u></b>
EOL	FLAG	STOP	-reserved-	Base	Base
				Count	Address
				[23:0]	[31:0]

The audio / modem interface is compliant with AC97. Refer to the AC97 specification and AC97 Codec data sheets for further details.

Read / Write through both functions 5 and 6.

**Offset 83-80 – AC97 Controller Command / Status.....RW**

Read / Write through both functions 5 and 6.

- 31-30 Codec ID** ..... RW
  - 00 Select Primary Codec
  - 01 Select Secondary Codec
  - 1x -reserved-
- 29-28 Reserved** ..... always reads 0
- 27 Secondary Codec Data / Status / Index Valid** .RWC
  - 0 Not Valid
  - 1 Valid (OK to Read bits 0-23)
- 26 Reserved** ..... always reads 0
- 25 Primary Codec Data / Status / Index Valid**.....RWC
  - 0 Not Valid
  - 1 Valid (OK to Read bits 0-23)
- 24 AC97 Controller Busy** ..... RO
  - 0 Primary Codec is ready for a register access command
  - 1 AC97 Controller is sending a command to the primary codec (commands are not accepted)
- 23 Codec Command Register Write Mode** ..... RW
  - 0 Select Codec command register write mode
  - 1 Select Codec command register read mode
- 22-16 Codec Command Register Index [7:1]** ..... RW  
Index of the AC97 codec command register to access (in the attached codec). Data must be written before or at the same time as Index as writing to the index triggers the AC97 controller to access the addressed codec register over the AC-link interface.
- 15-0 Codec Command Register Data / Status** ..... RW
  - W Codec Command Register Data
  - R Codec Status Register Data

**Offset 87-84 – SGD Status Shadow ..... RO**

Read / Only through both functions 5 and 6.

- 31-30 Reserved** ..... always reads 0
- 29 Modem Write Chan SGD Active Shadow**(Rx50[7])
- 28 Modem Read Chan SGD Active Shadow** (Rx40[7])
- 27-26 Reserved** ..... always reads 0
- 25 Modem Write Chan SGD STOP Shadow** (Rx50[2])
- 24 Modem Read Chan SGD STOP Shadow.** (Rx40[2])
- 23-22 Reserved** ..... always reads 0
- 21 Modem Write Chan SGD EOL Shadow..** (Rx50[1])
- 20 Modem Read Chan SGD EOL Shadow...** (Rx40[1])
- 19-18 Reserved** ..... always reads 0
- 17 Modem Write Chan SGD FLAG Shadow**(Rx50[0])
- 16 Modem Read Chan SGD FLAG Shadow** (Rx40[0])
- 15 Reserved** ..... always reads 0
- 14 FM Channel SGD Active Shadow**..... (Rx20[7])
- 13 Audio Write Chan SGD Active Shadow..** (Rx10[7])
- 12 Audio Read Chan SGD Active Shadow...** (Rx00[7])
- 11 Reserved** ..... always reads 0
- 10 FM Channel SGD STOP Shadow** ..... (Rx20[2])
- 9 Audio Write Chan SGD STOP Shadow ..** (Rx10[2])
- 8 Audio Read Chan SGD STOP Shadow ...** (Rx00[2])
- 7 Reserved** ..... always reads 0
- 6 FM Channel SGD EOL Shadow** ..... (Rx20[1])
- 5 Audio Write Chan SGD EOL Shadow ....** (Rx10[1])
- 4 Audio Read Chan SGD EOL Shadow ....** (Rx00[1])
- 3 Reserved** ..... always reads 0
- 2 FM Channel SGD FLAG Shadow**..... (Rx20[0])
- 1 Audio Write Chan SGD FLAG Shadow..** (Rx10[0])
- 0 Audio Read Chan SGD FLAG Shadow...** (Rx00[0])

Read / Only through function 5 and Read / Write through function 6:

**Offset 8B-88 – Codec GPI Interrupt Status / GPIO ... RWC**

- 31-16 GPI Interrupt Status** ..... RWC
  - R GPI[15-0] Interrupt Status
  - W 1 to clear
- 15-0 Codec GPIO** .....RW
  - R Reflect status of Codec GPI[15-0]
  - W Triggers AC-Link slot-12 output to codec

**Offset 8F-8C – Codec GPI Interrupt Enable ..... RW**

- 31-16 Interrupt on GPI[15-0] Change of Status**.....RW
  - 0 Disable
  - 1 Enable
- 15-0 Reserved** ..... always reads 0

**I/O Base 1 Registers – Audio FM NMI Status Registers**

These registers are accessible through **function 5 only**.

**I/O Offset 0 – FM NMI Status .....RO**

- 7-2 **Reserved** ..... always reads 0
- 1-0 **FM NMI Status**
  - 00 Undefined
  - 01 OPL3 Bank 0
  - 10 OPL3 Bank 1
  - 11 Undefined

**I/O Offset 1 – FM NMI Data.....RO**

- 7-0 **FM NMI Data**  
This register allows readback of the data written to the FM data port

**I/O Offset 2 – FM NMI Index .....RO**

- 7-0 **FM NMI Index**  
This register allows readback of the data written to the FM index port

**I/O Base 2 Registers – MIDI / Game Port**

These registers were added in chip version CF and CG and do not exist in versions CD and CE.

**I/O Offset 1-0 – MIDI Base..... RW**

- 15-0 **MIDI Port Base Address**..... default = 0330h

**I/O Offset 3-2 – Game Port Base..... RW**

- 15-0 **Game Port Base Address** ..... default = 0200h

These registers are functional only if Rx42[6] = 1

**Memory Mapped I/O APIC Registers (CG Silicon)**

**Memory Address FEC00000 – APIC Index.....RW**

**7-0 APIC Index** ..... default = 00h  
8-bit pointer to APIC registers.

**Memory Address FEC00013-10 – APIC 32-bit Data.....RW**

**31-0 APIC 32-bit Data** ..... default = 0000 0000h  
Data for the APIC register pointed to by the APIC index

**Memory Address FEC00020 – APIC IRQ Pin AssertionWO**

**7-5 Reserved** ..... always reads 0  
**4-0 APIC IRQ Number** .....default undefined  
IRQ # for this interrupt. Valid values are 0-23 only.

**Memory Address FEC00040 – APIC EOI..... WO**

**7-0 Redirection Entry Clear** .....default undefined  
When a write is issued to this register, the APIC will check this field and compare it with the vector field for each entry in the I/O redirection table. When a match is found, the “Remote\_IRR” bit for that I/O Redirection Entry will be cleared.

**Indexed I/O APIC 32-Bit Registers (CG Silicon)**

**Offset 0 – APIC Identification (0000 0000h)..... RW**

**31-28 Reserved** ..... always reads 0  
**27-24 APIC Identification** ..... default = 0  
Software must program this value before using the APIC.  
**23-0 Reserved** ..... always reads 0

**Offset 1 – APIC Version (0017 0011h)..... RO**

**31-24 Reserved** ..... always reads 00h  
**23-16 Maximum Redirection** ..... always reads 17h  
Equal to the number of APIC interrupt pins minus one. For this APIC, this value is 17h (23 decimal).  
**15-8 Reserved** ..... always reads 00h  
**7-0 APIC Version** ..... always reads 11h  
The implementation version for this APIC is 11h.

**Offset 2 – APIC Arbitration (0000 0000h)..... RO**

**31-28 Reserved** ..... always reads 00h  
**27-24 APIC Arbitration ID** ..... always reads 00h  
**23-0 Reserved** ..... always reads 00h

**Offset 3F-10 – I/O Redirection Table**

This table contains 24 registers, with one dedicated table entry for each of the 24 APIC interrupt signals. Each 64-bit register consists of two 32-bit values at consecutive index locations, with the low 32 bits at the even index and the upper 32 bits at the odd index. The default value for all registers is xxx1 xxxx xxxx xxxh.

- Offset 11-10 – I/O Redirection – APIC IRQ0 .....RW**
- Offset 13-12 – I/O Redirection – APIC IRQ1 .....RW**
- Offset 15-14 – I/O Redirection – APIC IRQ2 .....RW**
- Offset 17-16 – I/O Redirection – APIC IRQ3 .....RW**
- Offset 19-18 – I/O Redirection – APIC IRQ4 .....RW**
- Offset 1B-1A – I/O Redirection – APIC IRQ5.....RW**
- Offset 1D-1C – I/O Redirection – APIC IRQ6 .....RW**
- Offset 1F-1E – I/O Redirection – APIC IRQ7 .....RW**
- Offset 21-20 – I/O Redirection – APIC IRQ8 .....RW**
- Offset 23-22 – I/O Redirection – APIC IRQ9 .....RW**
- Offset 25-24 – I/O Redirection – APIC IRQ10 .....RW**
- Offset 27-26 – I/O Redirection – APIC IRQ11 .....RW**
- Offset 29-28 – I/O Redirection – APIC IRQ12 .....RW**
- Offset 2B-2A – I/O Redirection – APIC IRQ13.....RW**
- Offset 2D-2C – I/O Redirection – APIC IRQ14 .....RW**
- Offset 2F-2E – I/O Redirection – APIC IRQ15 .....RW**
- Offset 31-30 – I/O Redirection – APIC IRQ16 .....RW**
- Offset 33-32 – I/O Redirection – APIC IRQ17 .....RW**
- Offset 35-34 – I/O Redirection – APIC IRQ18 .....RW**
- Offset 37-36 – I/O Redirection – APIC IRQ19 .....RW**
- Offset 39-38 – I/O Redirection – APIC IRQ20 .....RW**
- Offset 3B-3A – I/O Redirection – APIC IRQ21.....RW**
- Offset 3D-3C – I/O Redirection – APIC IRQ22 .....RW**
- Offset 3F-3E – I/O Redirection – APIC IRQ23 .....RW**

- Offset 42 – SMI on BIOS Write.....RW**
- 0 Disable .....default
- 1 Enable

- Offset 4B-48 – General Purpose Input .....RW**
- 31-0 GPI 31-0

- Offset 4F-4C – General Purpose Output.....RW**
- 31-0 GPO 31-0

**Format for Each I/O Redirection Table Entry:**

- Physical Mode (bit-11=0)**
- 63-60 **Reserved** .....always reads 0
- 59-56 **APIC ID** ..... default = undefined
- Logical Mode (bit-11=1)**
- 63-56 **Destination** ..... default = undefined
- 55-17 **Reserved** .....always reads 0
- 16 **Interrupt Masked**
- 0 Not masked ..... default
- 1 Masked
- 15 **Trigger Mode**
- 0 Edge Sensitive ..... default
- 1 Level Sensitive
- 14 **Remote IRR (Level Sensitive Interrupts Only). RO**
- 0 EOI message with a matching interrupt vector received from a local APIC
- 1 Level sensitive interrupt sent by IOAPIC accepted by local APIC(s)
- 13 **Interrupt Input Pin Polarity**
- 0 Active High..... default
- 1 Active Low
- 12 **Delivery Status..... RO**
- Contains the current status of the delivery of this interrupt.
- 0 Idle (no activity)
- 1 Send Pending (the interrupt has been injected but its delivery is temporarily delayed either because the APIC bus is busy or because the receiving APIC unit cannot currently accept the interrupt)
- 11 **Destination Mode**
- Determines the interpretation of bits 56-63.
- 0 Physical Mode ..... default
- 1 Lowest Priority
- 10-8 **Delivery Mode**
- Specifies how the APICs listed in the destination field should act upon reception of this signal
- 000 Fixed ..... default
- 001 Logical Mode
- 010 SMI
- 011 -reserved-
- 100 NMI
- 101 INIT
- 110 -reserved-
- 111 External INT
- 7-0 **Interrupt Vector**
- Contains the interrupt vector for this interrupt. Vector values range from 10h to FEh.

# FUNCTIONAL DESCRIPTIONS

## Power Management

### Power Management Subsystem Overview

The power management function of the VT82C686A is indicated in the following block diagram:

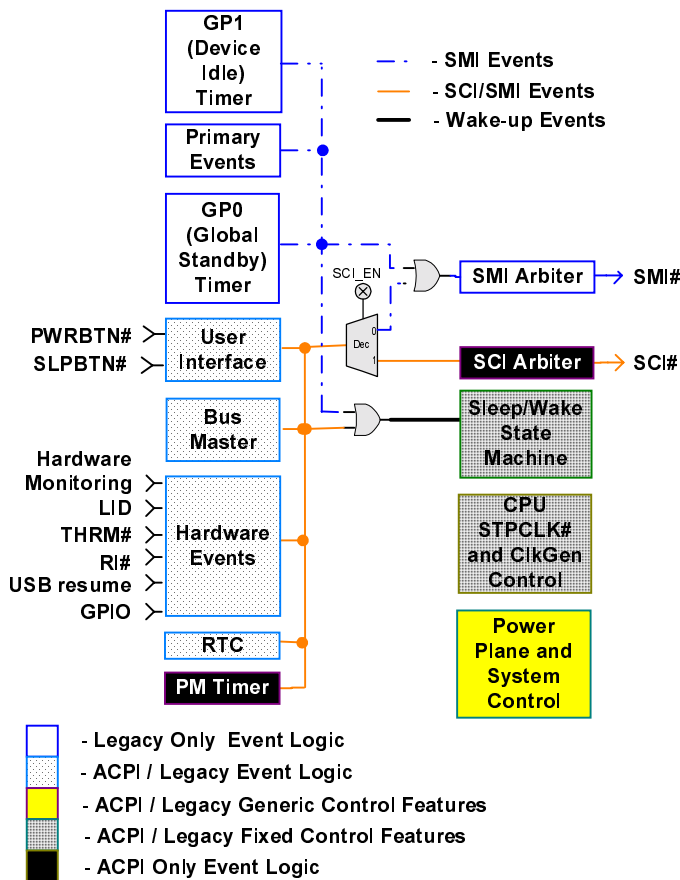

Figure 6. Power Management Subsystem Block Diagram

Refer to ACPI Specification v1.0 and APM specification v1.2 for additional information.

### Processor Bus States

The VT82C686A supports the complete set of C0 to C3 processor states as specified in the Advanced Configuration and Power Interface (ACPI) specification (and defined in ACPI I/O space Registers 10-15):

- C0: Normal Operation
- C1: CPU Halt (controlled by software).
- C2: Stop Clock. Entered when the P\_LVL2 register is read. The STPCLK# signal is asserted to put the processor in the Stop Grant State. The CPUSTP# signal is not asserted so that host clocks remain running. To exit this state, the chip negates STPCLK#.
- C3: Suspend. Entered when the P\_LVL3 register is read. In addition to STPCLK# assertion as in the C2 state, the SUSST1# (suspend status 1) signal is asserted to tell the north bridge to switch to "Suspend DRAM Refresh" mode based on the 32KHz suspend clock (SUSCLK) provided by the VT82C686A. If the HOST\_STP bit is enabled, then CPUSTP# is also asserted to stop clock generation and put the CPU into Stop Clock State. To exit this state, the chip negates CPUSTP# and allows time for the processor PLL to lock. Then the SUSST1# and STPCLK# signals are negated to resume to normal operation.

During normal operation, two mechanisms are provided to modulate CPU execution and control power consumption by throttling the duty cycle of STPCLK#:

- a. Setting the THT\_EN bit to 1, the duty cycle defined in THT\_DTY (IO space Rx10) is used.
- b. THRM# pin assertion enables automatic clock throttling with duty cycle pre-configured in THM\_DTY (PCI configuration Rx4C).



### **System Suspend States and Power Plane Control**

There are three power planes inside the VT82C686A. The first power plane (VCCS) is always on unless turned off by the mechanical switch. The second power plane (VCC) is controlled by chip output SUSC# (also called "PSON"). The third plane (VCCRTC) is powered by the combination of the VCCS and the external battery (VBAT) for the integrated real time clock. Most of the circuitry inside the VT82C686A is powered by VCC. The amount of logic powered by VCCS is very small; its main function is to control the supply of VCC and other power planes. VCCRTC is always on unless both the mechanical switch and VBAT are removed.

The VT82C686A supports multiple system suspend states by configuring the SLP\_TYP field of ACPI I/O space register Rx4-5:

- a) **POS (Power On Suspend):** Most devices in the system remain powered. The host bus is put into an equivalent of the C3 state. In particular, the CPU is put into the Stop Grant State or Stop Clock State depending on the setting of the HOST\_STP bit. SUSST1# is asserted to tell the north bridge to switch to "Suspend DRAM Refresh" mode based on the 32KHz SUSCLK provided by the VT82C686A. As to the PCI bus, setting the PCLK\_RUN bit to 0 enables the CLKRUN protocol defined in the PCI Mobile Design Guide. That is, the PCKRUN# pin will be de-activated after the PCI bus is idle for 26 clocks. Any PCI bus masters including the north bridge may resume PCI clock operation by pulling the PCKRUN# pin low. During the PCKRUN# de-activation period, the PCISTP# pin may be activated to disable the output of the PCI clock generator if the PCI\_STP bit is enabled. When the system resumes from POS, the VT82C686A can optionally resume without resetting the system, can reset the processor only, or can reset the entire system. When no reset is performed, the chip only needs to wait for the clock synthesizer and processor PLL to lock before the system is resumed, which typically takes 20ms.
- b) **STR (Suspend to RAM):** Power is removed from most of the system except the system DRAM. Power is supplied to the suspend refresh logic in the north bridge (VTT of VT82C598) and the suspend logic of the VT82C686A (VCCS). The VT82C686A provides a 32KHz suspend clock to the north bridge for it to use to continue DRAM refresh.
- c) **STD (Suspend to Disk, also called Soft-off):** Power is removed from most of the system except the suspend logic of VT82C686A (VCCS).
- d) **Mechanical Off:** This is not a suspend state. All power in the system is removed except the RTC battery.

The suspend state is entered by setting the SLP\_EN bit to 1. Three power plane control signals (SUSA#, SUSB# and

SUSC#) are provided to turn off more system power planes as the system moves to deeper power-down states, i.e., from normal operation to POS (only SUSA# asserted), to STR (both SUSA# and SUSB# asserted), and to STD (all three SUS# signals asserted). In particular, the assertion of SUSC# can be used to turn off the VCC supply to the VT82C686A.

One additional suspend status indicator (SUSST1#) is provided to inform the north bridge and the rest of the system of the processor and system suspend states. SUSST1# is asserted when the system enters the suspend state or the processor enters the C3 state. SUSST1# is connected to the north bridge to switch between normal and suspend-DRAM-refresh modes.

### **General Purpose I/O Ports**

As ACPI compliant hardware, the VT82C686A includes PWRBTN#, SLPBTN#, and RI# pins to implement power button, sleep button, and ring indicator functionality, respectively. Furthermore, the VT82C686A offers many general-purpose I/O ports with the following capabilities:

- **I<sup>2</sup>C/SMB Support**
- **Thermal Detect**
- **Notebook Lid Open/Close Detect**
- **Battery Low Detect**
- **Twelve General Purpose Input Ports** (multiplexed with other functions).
- **Nineteen General Purpose Output Ports** (1 dedicated and 18 multiplexed with other functions)
- **Four General Purpose Input / Output Ports** (multiplexed with other functions)

In addition, the VT82C686A provides an external dedicated SMI pin (EXTSMI#). The external SMI input can be programmed to trigger an SCI or SMI at both the rising and falling edges of the corresponding input signal. Software can check the status of the input pin and take appropriate actions.

**Power Management Events**

Three types of power management events are supported:

- 1) **ACPI-required Fixed Events** defined in the PM1a\_STS and PM1a\_EN registers. These events can trigger either SCI or SMI depending on the SCI\_EN bit:
  - PWRBTN# Triggering
  - RTC Alarm
  - Sleep Button
  - ACPI Power Management Timer Carry (always SCI)
  - BIOS Release (always SCI)
- 2) **ACPI-aware General Purpose Function Events** defined in the GP\_STS and GP\_SCI\_EN, and GP\_SMI\_EN registers. These events can trigger either SCI or SMI depending on the setting of individual SMI and SCI enable bits:
  - External SMI triggering
  - USB Resume
  - Ring Indicator (RI#)
  - Battery Low Detect (BATLOW#)
  - Notebook Lid Open/Close Detect (LID)
  - Thermal Detect (THRM#)

- 3) **Generic Global Events** defined in the GBL\_STS and GBL\_EN registers. These registers are mainly used for SMI:
  - PCI Bus Clock Run Resume
  - Primary Interrupt Occurance
  - GP0 and GP1 Timer Time Out
  - Secondary Event Timer Time Out
  - Occurrence of Primary Events (defined in register PACT\_STS and PACT\_EN)
  - Legacy USB accesses (keyboard and mouse)
  - Software SMI

**System and Processor Resume Events**

Depending on the system suspend state, different features can be enabled to resume the system. There are two classes of resume events:

- a) **VCCS-based events.** Event logic resides in the VCCS plane and thus can resume the system from any suspend state. Such events include PWRBTN#, RI#, BATLOW#, LID, SMBus resume event, RTC alarm, EXTSMI#, and GP1 (EXTSMI1#).
- b) **VCC-Based Events.** Event logic resides in the VCC plane and thus can only resume the system from the POS state. Such events include the ACPI PM timer, USB resume, and EXTSMIn#.

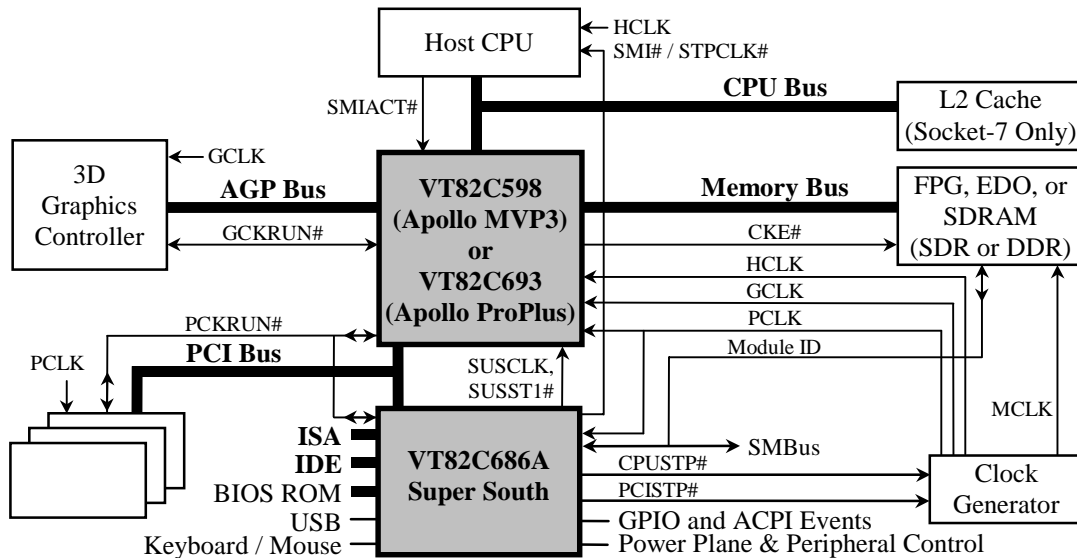

**Figure 7. System Block Diagram Using the VT82C686A Super South Bridge**



### Legacy Power Management Timers

In addition to the ACPI power management timer, the VT82C686A includes the following four legacy power management timers:

- GP0 Timer:** general purpose timer with primary event
- GP1 Timer:** general purpose timer with peripheral event reload
- Secondary Event Timer:** to monitor secondary events
- Conserve Mode Timer:** Hardware-controlled return to standby

The normal sequence of operations for a general purpose timer (GP0 or GP1) is to

- 1) First program the time base and timer value of the initial count (register GP\_TIM\_CNT).
- 2) Then activate counting by setting the GP0\_START or GP1\_START bit to one: the timer will start with the initial count and count down towards 0.
- 3) When the timer counts down to zero, an SMI will be generated if enabled (GP0TO\_EN and GP1TO\_EN in the GBL\_EN register) with status recorded (GP0TO\_STS and GP1TO\_STS in the GBL\_STS register).
- 4) Each timer can also be programmed to reload the initial count and restart counting automatically after counting down to 0. This feature is not used in standard VIA BIOS.

The GP0 and GP1 timers can be used just as the general purpose timers described above. However, they can also be programmed to reload the initial count by system primary events or peripheral events thus used as primary event (global standby) timer and peripheral timer, respectively. The secondary event timer is solely used to monitor secondary events.

### System Primary and Secondary Events

Primary system events are distinguished in the PRI\_ACT\_STS and PRI\_ACT\_EN registers:

<u>Bit</u>	<u>Event</u>	<u>Trigger</u>
7	<b>Keyboard Access</b>	I/O port 60h
6	<b>Serial Port Access</b>	I/O ports 3F8h-3FFh, 2F8h-2FFh, 3E8h-3EFh, or 2E8h-2EFh
5	<b>Parallel Port Access</b>	I/O ports 378h-37Fh or 278h-27Fh
4	<b>Video Access</b>	I/O ports 3B0h-3DFh or memory A/B segments
3	<b>IDE/Floppy Access</b>	I/O ports 1F0h-1F7h, 170h-177h, or 3F5h
2	<b>Reserved</b>	
1	<b>Primary Interrupts</b>	Each channel of the interrupt controller can be programmed to be a primary or secondary interrupt

#### 0 ISA Master/DMA Activity

Each category can be enabled as a primary event by setting the corresponding bit of the PRI\_ACT\_EN register to 1. If

enabled, the occurrence of the primary event reloads the GP0 timer if the PACT\_GP0\_EN bit is also set to 1. The cause of the timer reload is recorded in the corresponding bit of PRI\_ACT\_STS register while the timer is reloaded. If no enabled primary event occurs during the count down, the GP0 timer will time out (count down to 0) and the system can be programmed (setting the GP0TO\_EN bit in the GBL\_EN register to one) to trigger an SMI to switch the system to a power down mode.

The VT82C686A distinguishes two kinds of interrupt requests as far as power management is concerned: the primary and secondary interrupts. Like other primary events, the occurrence of a primary interrupt demands that the system be restored to full processing capability. Secondary interrupts, however, are typically used for housekeeping tasks in the background unnoticeable to the user. The VT82C686A allows each channel of interrupt request to be declared as either primary, secondary, or ignorable in the PIRQ\_CH and SIRQ\_CH registers. Secondary interrupts are the only system secondary events defined in the VT82C686A.

Like primary events, primary interrupts can be made to reload the GP0 timer by setting the PIRQ\_EN bit to 1. Secondary interrupts do not reload the GP0 timer. Therefore the GP0 timer will time out and the SMI routine can put the system into power down mode if no events other than secondary interrupts are happening periodically in the background.

Primary events can be programmed to trigger an SMI (setting of the PACT\_EN bit). Typically, this SMI triggering is turned off during normal system operation to avoid degrading system performance. Triggering is turned on by the SMI routine before entering the power down mode so that the system may be returned to normal operation at the occurrence of primary events. At the same time, the GP0 timer is reloaded and the count down process is restarted.

### Peripheral Events

Primary and secondary events define system events in general and the response is typically expressed in terms of system events. Individual peripheral events can also be monitored by the VT82C686A through the GP1 timer. The following four categories of peripheral events are distinguished (via register GP\_RLD\_EN):

- Bit-7 **Keyboard Access**
- Bit-6 **Serial Port Access**
- Bit-4 **Video Access**
- Bit-3 **IDE/Floppy Access**

The four categories are subsets of the primary events as defined in PRI\_ACT\_EN and the occurrence of these events can be checked through a common register PRI\_ACT\_STS. As a peripheral timer, GP1 can be used to monitor one (or more than one) of the above four device types by programming the corresponding bit to one and the other bits to zero. Time out of the GP1 timer indicates no activity of the corresponding device type and appropriate action can be taken as a result.

# ELECTRICAL SPECIFICATIONS

## Absolute Maximum Ratings

Parameter	Min	Max	Unit	Comment
Storage temperature	-55	125	°C	T <sub>S</sub>
Operating temperature - Case	0	85	°C	T <sub>C</sub>
Operating temperature - Ambient	0	70	°C	T <sub>A</sub>
Reference Voltage	0	5.5	Volts	V <sub>REF</sub>
Core Voltage	0	3.6	Volts	V <sub>CC</sub>
Suspend Voltage	-0.5	V <sub>CC</sub> + 0.3	Volts	V <sub>SUS</sub>
USB Voltage	-0.5	V <sub>CC</sub> + 0.3	Volts	V <sub>USB</sub>
Hardware Monitor Voltage	-0.5	V <sub>CC</sub> + 0.3	Volts	V <sub>HWM</sub>
Battery Voltage	-0.5	V <sub>CC</sub> + 0.3	Volts	V <sub>BAT</sub>
Input voltage (3.3V only inputs)	-0.5	V <sub>CC</sub> + 0.3	Volts	FERR#, USBCLK, PWRBTN#, EXTSMI#, BATLOW#, FAN1, FAN2, SMBCLK, SMBDATA
Input voltage (5V tolerant inputs)	-0.5	V <sub>REF</sub> + 0.5	Volts	All other inputs

Note: Stress above the conditions listed may cause permanent damage to the device. Functional operation of this device should be restricted to the conditions described under operating conditions.

## DC Characteristics

T<sub>A</sub> -0-70°C, V<sub>REF</sub>=5V ±5%, V<sub>CC</sub>= V<sub>CCS</sub>= V<sub>CCH</sub>= V<sub>CCU</sub>=3.3V ±0.3V, V<sub>BAT</sub>=3.3V +0.3/-1.3V, GND=0V

Symbol	Parameter	Min	Max	Unit	Condition
V <sub>IL</sub>	Input low voltage	-0.5	0.8	V	
V <sub>IH</sub>	Input high voltage	2.0	V <sub>CC</sub> +0.3	V	
V <sub>OL</sub>	Output low voltage	-	0.45	V	I <sub>OL</sub> = 4.0mA
V <sub>OH</sub>	Output high voltage	2.4	-	V	I <sub>OH</sub> = -1.0mA
I <sub>IL</sub>	Input leakage current	-	±10	uA	0 < V <sub>IN</sub> < V <sub>CC</sub>
I <sub>OZ</sub>	Tristate leakage current	-	±20	uA	0.45 < V <sub>OUT</sub> < V <sub>CC</sub>
I <sub>CC</sub>	Power supply current	-	80	mA	

# PACKAGE MECHANICAL SPECIFICATIONS

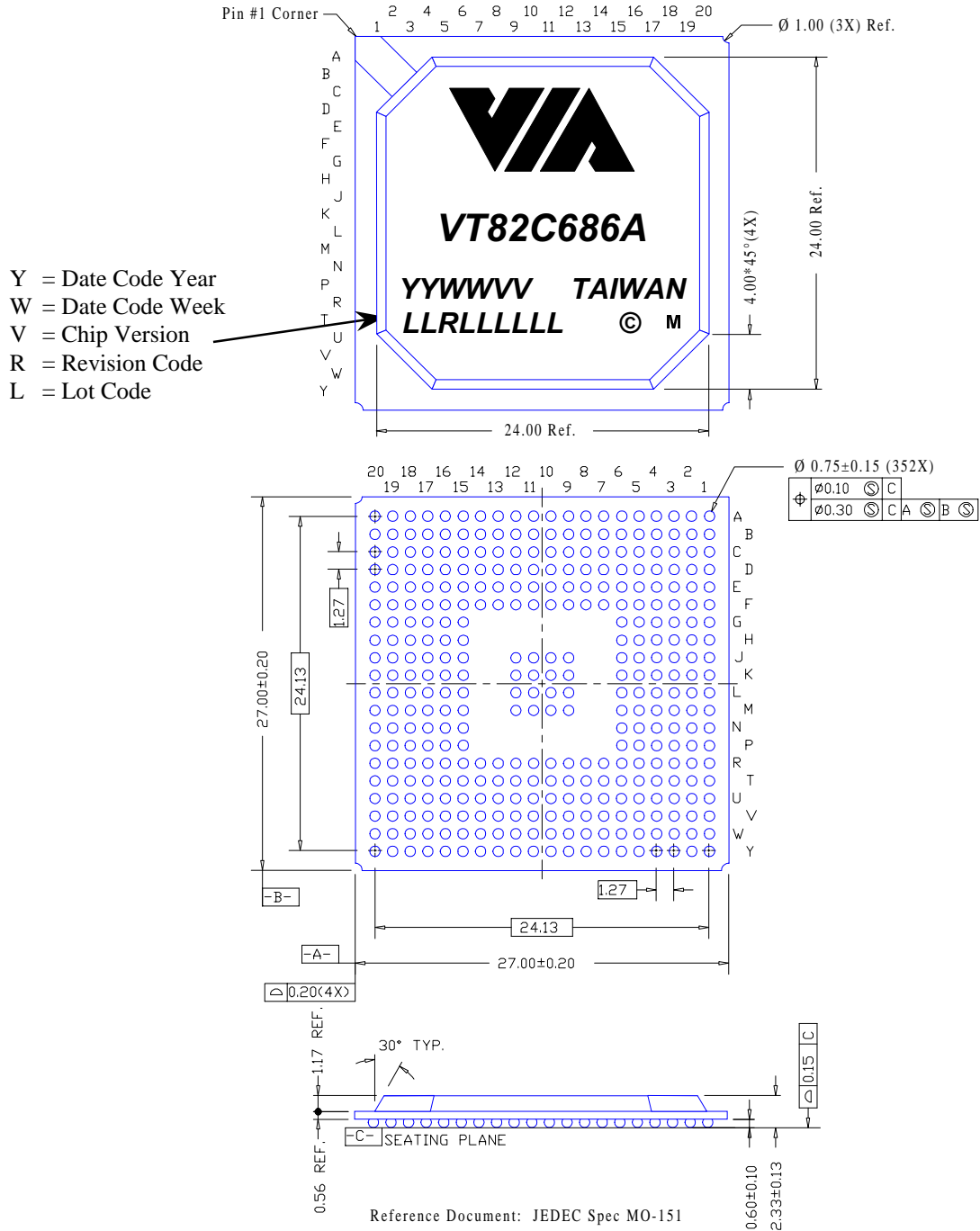

Figure 8. Mechanical Specifications – 352 Pin Ball Grid Array Package