

**82C110  
IBM™ PS/2 MODEL 30 AND SUPER XT™ COMPATIBLE CHIP**

- 100% PC/XT compatible
- Build IBM PS/2™ Model 30 with XT software compatibility
- Bus Interface compatible with 8086, 80C86, V30, 8088, 80C88, V20
- Includes all PC/XT functional units compatible with:
  - 8284, 8288, 8237, 8259, 8254, 8255, DRAM control, Keyboard control, Parity Generation and Configuration registers
- Key superset features: EMS control, dual clock, and 2.5 MB DRAM support
- Complete system requires 12 ICs plus memory
- 10 MHz Zero wait state operation
- Applicable for high performance Desktop PCs and CMOS Industrial Control Applications
- Single chip implementation available in 100-pin flat pack

The 82C110 is a single chip implementation of most of the system logic necessary to implement a super XT compatible system with PS/2 Model 30 functionality using either an 8086 or 8088 microprocessor. The 82C110 can be used with either 8 or 16-bit microprocessors. The 82C110 includes features which will enable the PC manufacturer to design a super PS/2 Model 30/XT compatible system with the *highest performance* at 10 MHz zero wait state system with an 8086, the *highest func-*

*tionality* with dual clock and 2.5 MB DRAM (with integrated Extended Memory System control logic), the *highest integration* with the lowest component count SMT design.

The 82C110 can be combined with CHIPS' 82C601 Multifunction Controller and 82C451 VGA Graphics Controller to provide a high performance, high integration PS/2 Model 30 type system.

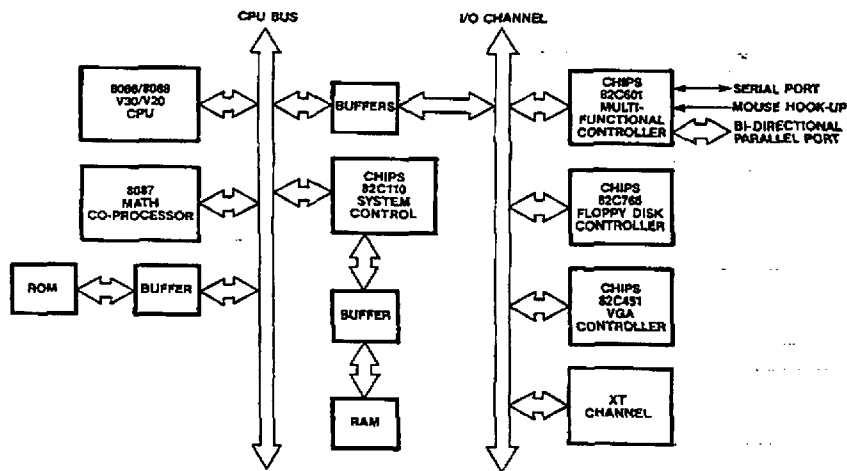

Figure 1. Super XT Model 30 Compatible System

The 82C110 supports most of the peripheral functions on the PS/2 Model 30 planar board: 8284 compatible clock generator with the option of 2 independent oscillators, 8288 compatible bus controller, 8237 compatible DMA controller, 8259 compatible interrupt controller, 8254 compatible timer/counter, 8255 compatible peripheral I/O port, XT Keyboard interface, Parity Generation and Checking for DRAM memory and memory controller for DRAM memory sub-system.

The 82C110 enables the user to add PS/2 Model 30 superset functionality on the planar board: dual clock with synchronized switching between the two clocks, built-in Lotus-Intel-Microsoft™ (LIM) EMS support for up to 2.5 Megabytes of DRAM.

The 82C110 supports a very flexible memory architecture. The DRAM controller supports 64K, 256K and 1M DRAMs. These DRAMs can be organized in four banks of up to a maximum of 2.5 MB on the planar board. The 2.5 MB memory can be implemented with 2 banks of 1M X 1 DRAMs, partitioned locally as 640KB of real memory and 1.875 MB of EMS memory.

The 82C110 is packaged in a 100-pin plastic flatpack.

#### CHIPS and Technologies, Inc.

3050 Zanker Road, San Jose, CA 95134 408-434-0600 Telex 272929 CHIPS UR

#### COPYRIGHT NOTICE

Copyright © 1990, Chips and Technologies, Inc. ALL RIGHTS RESERVED.

This manual is copyrighted by Chips and Technologies, Inc. You may not reproduce, transmit, transcribe, store in a retrieval system, or translate into any language or computer language, in any form or by any means, electronic, mechanical, magnetic, optical, chemical, manual, or otherwise, any part of this publication without the express written permission of Chips and Technologies.

#### TRADEMARKS

CHIPS, NEAT, CHIPSport are registered trademarks of Chips and Technologies, Inc. CHIPSset, LeAPset, LeAPset-sx, PEAKset/386, NEATsx, CHIPS/250, CHIPS/280, SCAT, MicroCHIPS, M/PAX, CHIPSlink, CHIPSterm, CHIPSpak are registered trademarks of Chips and Technologies, Inc.

IBM, EGA, IBM PC, IBM PC AT, IBM XT, and IBM PC XT are registered trademarks of International Business Machines Corporation. PS/2, Micro Channel, and Personal System/2 are trademarks of International Business Machines Corporation.

MS-DOS is a registered trademark of Microsoft Corporation.

Intel, 386, 387, 386SX and 387SX are trademarks of Intel Corporation.

#### DISCLAIMER

Chips and Technologies, Inc. makes no representations or warranties regarding the contents of this manual. We reserve the right to revise the manual or make changes in the specifications of the product described within it at any time without notice and without obligation to notify any person of such revision or change.

The information contained in this manual is provided for general use by our customers. Our customers should be aware that the personal computer field is the subject of many patents. Our customers should ensure that they take appropriate action so that their use of our products does not infringe upon any patents. It is the policy of Chips and Technologies, Inc. to respect the valid patent rights of third parties and not to infringe upon or assist others to infringe upon such rights.

#### RESTRICTED RIGHTS LEGEND

Use, duplication, or disclosure by the Government is subject to restrictions set forth in subparagraph (c) (1) (ii) of the Rights in Technical Data and Computer Software clause at 252.277-7013.

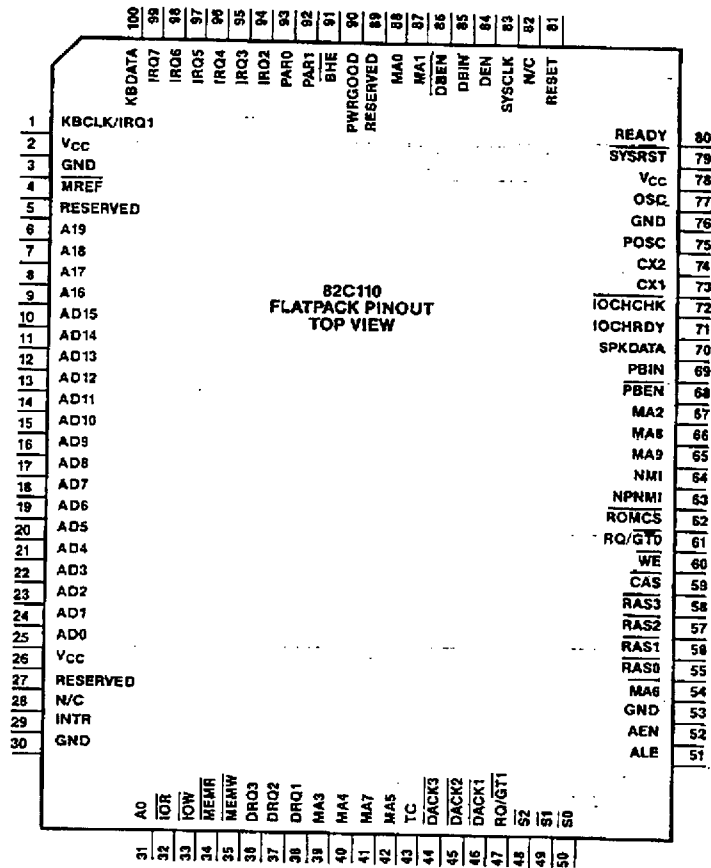

**82C110 Pin Description**

Pin No.	Pin Type	Symbol	Pin Description
<b>Clocks and Reset Logic</b>			
73	I	CX1	<b>Crystal/oscillator input.</b> CX1 is an input for a passive crystal circuit or packaged oscillator to generate the initial system timings. This frequency is divided by three to generate the default system clock when the system is powered up. The type of crystal is 14.31818 MHz, parallel resonance, fundamental frequency.
74	O	CX2	<b>Crystal/oscillator output.</b> CX2 is the inverted output of CX1. If a crystal is used, then CX2 should be connected to the crystal circuit. If an oscillator is used, then CX2 should be left unconnected.
75	I	POSC	<b>Optional Oscillator input.</b> The POSC input is divided by three to generate alternate system timing (other than 4.77 MHz). Typically POSC is a 24 MHz or 30 MHz oscillator with a 50% duty cycle, for 8 MHz or 10 MHz systems, respectively. The maximum POSC frequency is 30 MHz. System timing is software selectable from the configuration register.
83	O	SYSCLK	<b>System Clock.</b> SYSCLK is a continuous running clock with selectable frequency and duty cycle. The duty cycle is either 33% for INTEL 808X CPUs, or 50% for NEC V20/30 CPUs. The SYSCLK frequency is selected from either 1/3 of the POSC or 1/3 of the CX1 frequencies. The default is 4.77 MHz, 33% duty cycle.
77	O	OSC	<b>Oscillator output.</b> OSC is a continuous running square wave with a 50% duty cycle, derived from the frequency generated by CX1. Normally this is used for the 14.318 MHz.
90	I	PWRGOOD	<b>Power Good.</b> An active high indicator that the power supply is stable, it also starts the clocks and the internal system functions. PWRGOOD is generated by the power supply, by monitoring V <sub>CC</sub> .

**82C110 Pin Description (Continued)**

Pin No.	Pin Type	Symbol	Pin Description															
79	I	$\overline{\text{SYSRST}}$	<b>System Reset.</b> $\overline{\text{SYSRST}}$ is an active low Schmitt trigger input for power-up reset. $\overline{\text{SYSRST}}$ initializes the 82C110 circuitry. This signal also generates the RESET output used to reset the CPU, 8087 and other peripherals. It should be held active until $\overline{\text{PWRGOOD}}$ becomes active.															
<b>CPU Interface</b>																		
81	O	RESET	<b>RESET.</b> RESET is an active high output derived from the $\overline{\text{SYSRST}}$ input. RESET should be used to reset the CPU, the 8087, and the external peripherals.															
48	I	$\overline{\text{S2}}$	<b>Processor Status Signals.</b> These signals are status inputs from the CPU. $\overline{\text{S0-S2}}$ should be pulled up with 4.7K-10K resistors.															
49	I	$\overline{\text{S1}}$																
50	I	$\overline{\text{S0}}$																
91	I	$\overline{\text{BHE}}$	<b>Byte High Enable.</b> $\overline{\text{BHE}}$ is an input signal. $\overline{\text{BHE}}$ and A0 from the CPU indicate the type of bus transfer.															
<table border="1"> <thead> <tr> <th><math>\overline{\text{BHE}}</math></th> <th>A0</th> <th>Type</th> </tr> </thead> <tbody> <tr> <td>0</td> <td>0</td> <td>16 bit transfer</td> </tr> <tr> <td>0</td> <td>1</td> <td>odd byte transfer</td> </tr> <tr> <td>1</td> <td>0</td> <td>even byte transfer</td> </tr> <tr> <td>1</td> <td>1</td> <td>invalid (for 16 bit CPU)</td> </tr> </tbody> </table>				$\overline{\text{BHE}}$	A0	Type	0	0	16 bit transfer	0	1	odd byte transfer	1	0	even byte transfer	1	1	invalid (for 16 bit CPU)
$\overline{\text{BHE}}$	A0	Type																
0	0	16 bit transfer																
0	1	odd byte transfer																
1	0	even byte transfer																
1	1	invalid (for 16 bit CPU)																
<p>If the 82C110 is used with an 8 bit processor, <math>\overline{\text{BHE}}</math> should be tied high through a 4.7K to 10K resistor. The 82C110 uses the "invalid" state to perform the correct bus conversion for a 16-bit processor. <math>\overline{\text{BHE}}</math> is floated to the high impedance state during "hold" cycles, so it should be pulled up with 4.7K-10K resistor.</p>																		
80	O	READY	<b>READY.</b> READY is an active high, asynchronous output indicates that a memory or I/O transfer can complete. READY is internally synchronized to meet the setup/hold times of the processor.															

**82C110 Pin Description (Continued)**

Pin No.	Pin Type	Symbol	Pin Description
29	O	INTR	<b>Interrupt Request.</b> INTR is an active high output from the internal Interrupt Controller. It should be connected to the INTR pin of the CPU.
54	O	NMI	<b>Non-Maskable Interrupt.</b> A LOW to HIGH transition on NMI causes an interrupt at the end of the current instruction. It should be connected to the NMI input of the CPU.
61 47	B B	RQ/GT0 RQ/GT1	<b>Request/Grant.</b> These signals are used by bus masters other than the CPU to gain control of the CPU local bus. In the Model 25/30 or XT application, the other bus masters are the 8087 numeric co-processor, and the 82C110 itself. RQ/GT0 has higher priority than RQ/GT1. 808X RQ/GT signals are internally pulled up, so external pullups are not necessary. See the Request/Grant section of this data sheet for more information.

**Local Bus Interface**

6	B	A19	<b>Address Bits A19-16.</b> During processor cycles, these are inputs for the high order address bits. During DMA cycles, the 82C110 sources the high order address on these lines. These should be connected directly to the processor address lines and to the system address latches.
7	B	A18	
8	B	A17	
9	B	A16	
10	B	AD15	<b>Local Address/Data Bus Bits 15:0.</b> During the T1 phase of a CPU cycle the processor sources the address on these lines. The 82C110 sources the address during hold acknowledge and interrupt acknowledge cycles. AD0-AD7 should be isolated from the 82C110 using bidirectional buffers to prevent bus contention during bus conversion cycles. PBEN enables the buffers and PBIN controls the direction.
11	B	AD14	
12	B	AD13	
13	B	AD12	
14	B	AD11	
15	B	AD10	
16	B	AD9	
17	B	AD8	
18	B	AD7	
19	B	AD6	
20	B	AD5	
21	B	AD4	
22	B	AD3	
23	B	AD2	
24	B	AD1	
25	B	AD0	
31	O	A0	<b>Address Bit 0.</b> This signal represents the state of address bit 0. It is latched and should be used throughout the system instead of AD0 that would normally be latched externally from the AD bus. The 82C110 toggles this bit during bus conversion cycles. It should be buffered (in a normal system) but not routed through transparent latches like the other address bits.

## 82C110 Pin Description (Continued)

Pin No.	Pin Type	Symbol	Pin Description
32	O	IOR	<b>I/O Read.</b> An active low strobe that informs the I/O devices to put their data on the bus. All the commands (MEMR, MEMW, IOR, and IOW) can be delayed one cycle through software. The delay is necessary when running the CPU at high speed. Delaying the commands allow more data and address setup time. Default is no delay.
33	O	IOW	<b>I/O Write.</b> An active low strobe that informs the I/O devices that data is available on the bus.
34	O	MEMR	<b>Memory Read.</b> An active low strobe that informs the memory devices to put their data on the bus.
35	O	MEMW	<b>Memory Write.</b> An active low strobe that informs the memory devices that data is available on the bus.
51	O	ALE	<b>Address Latch Enable.</b> ALE is used by the address buffer/latch to latch the address. During the second half of a bus conversion cycle, a second ALE will not be generated by the 82C110.
52	O	AEN	<b>Address Enable.</b> When high, this signal is an indication to the devices on the I/O channel that DMA is active, meaning the DMA channel has control of the address bus, data bus, and the appropriate command lines.
84	O	DEN	<b>Data Enable.</b> Provided to control the output enable of 245 type transceiver. DEN is active during memory and I/O accesses and for INTA cycles. It floats to the high impedance state in "hold acknowledge" cycles. This signal is equivalent to the DEN signal generated by an 8288 bus controller. It is normally not used in XT/Model 30 type applications.
93	B	PAR0	<b>Parity Bit 0.</b> The parity bit from the low order byte of the DRAMs. A HIGH means there are an odd number of 1's in memory, including the parity bit itself, thus odd parity.
92	B	PAR1	<b>Parity Bit 1.</b> The parity bit from the high order byte of the DRAMs. A HIGH means there are an odd number of 1's in memory, including the parity bit itself, thus odd parity. This signal is not used in 8 bit only systems.
71	I	IOCHRDY	<b>I/O Channel Ready.</b> An active high signal from the I/O channel. It is normally HIGH indicating that the addressed device on the channel is ready to complete the data transfer. Slow I/O or memory devices pull this signal LOW to lengthen bus cycles. IOCHRDY should be pulled up with a 4.7K resistor, because if there are no add-in boards present, this signal would float to an undefined state.

**82C110 Pin Description (Continued)**

Pin No.	Pin Type	Symbol	Pin Description
72	I	IOCHCHK	<b>I/O Channel Check.</b> This signal goes low when there is parity or other error on memory or devices on the I/O channel. IOCHCHK should be pulled up with a 4.7K resistor, because if there are no add-in boards present, this signal would float to an undefined state.
<b>Buffer Controls</b>			
86	O	DBEN	<b>Data Buffer Enable.</b> DBEN enables the data transceiver between the I/O channel data bus and 82C110.
85	O	DBIN	<b>Data Buffer Direction.</b> A HIGH allows data to flow from the I/O channel to the internal bus. Normally low, this means the data direction is to the I/O channel. DBIN is used to control the direction of the buffer for the system data bus.
68	O	PBEN	<b>Processor Buffer Enable.</b> An active low signal, PBEN enables the data buffer between the processor and the 82C110. It is high during DMA cycles so that the data bus is tri-stated. PBEN is qualified with DEN to avoid bus contention during T2 cycles.
69	O	PBIN	<b>Processor Buffer Direction.</b> A HIGH on PBIN allows data to flow from the processor to the 82C110. PBIN controls the direction of the data buffer on the local data bus.
<b>Memory Controls</b>			
62	O	ROMCS	<b>ROM Chip Select.</b> This signal goes low for memory accesses in the address range F0000H-FFFFFH. It would normally be tied to the chip select inputs of the BIOS ROM(s).
<b>Note:</b> All DRAM signals (MA9-0, RAS3-0, CAS and WE should be buffered if connected to more than 9 memory devices)			
65	O	MA9	<b>Multiplex Address Bits 9-0.</b> Should be connected to DRAM address bits 9-0.
66	O	MA8	
41	O	MA7	
54	O	MA6	
42	O	MA5	
40	O	MA4	
39	O	MA3	
67	O	MA2	
87	O	MA1	
88	O	MA0	



82C110 Pin Description (Continued)

Pin No.	Pin Type	Symbol	Pin Description
55	O	RAS0	RAS3-0. Active low row address strobes for DRAM banks 0-3. Each bank is 9 bits wide (1 bit for parity). Byte referencing is done using the RAS signal. For more information, see the DRAM Interface section of this data sheet.
56	O	RAS1	
57	O	RAS2	
58	O	RAS3	
59	O	CAS	CAS. Active low column address strobe for all DRAMs.
60	O	WE	WE. Active low write enable for all DRAMs.
4	O	MREF	Memory Refresh. MREF is the output of the independent refresh timer signifying that a refresh cycle is occurring. The refresh rate is programmable from 838 ns to 214 $\mu$ s.
<b>DMA and Interrupt Controller Interface</b>			
36	I	DRQ3	DMA Request 3-1. These signals are asynchronous requests used by peripherals to request DMA services. They have a fixed priority: channel 1 is the highest and channel 3 is the lowest. DRQ must be held active HIGH until it is acknowledged by the corresponding DACK.
37	I	DRQ2	
38	I	DRQ1	

**82C110 Pin Description (Continued)**

Pin No.	Pin Type	Symbol	Pin Description
44	O	<u>DACK3</u>	<b>DMA Acknowledge 3-1.</b> An active low acknowledgement signal generated by the 82C110 as a result of a request for DMA service (via a DRQ line) and a successful arbitration. These lines must be pulled up with 10Kohm resistors.
45	O	<u>DACK2</u>	
46	O	<u>DACK1</u>	
43	O	TC	<b>Terminal Count.</b> An active high output pulse from the DMA Controller, indicating the end of a DMA transfer (transfer count register = 0).
94	I	IRQ2	<b>Interrupt Request 2-7.</b> Active high asynchronous inputs to the interrupt controller generated by I/O devices. They are edge-triggered, but should be held active HIGH until acknowledged.
95	I	IRQ3	
96	I	IRQ4	
97	I	IRQ5	
98	I	IRQ6	
99	I	IRQ7	
63	I	NPNMI	<b>Numeric Co-Processor NMI.</b> An active high signal indicating that an error has occurred during numeric instruction execution. This is an active high, edge-sensitive input. If enabled, will cause an NMI to the CPU. The NMI service routine has to determine which NMI occurred by reading the NMI Status Register.
<b>Keyboard and Speaker Interface</b>			
1	B	KBCLK/IRQ1	<b>Keyboard Clock/Interrupt Request 1.</b> KBCLK is a bidirectional open drain signal. Defaults to KBCLK when using an XT style keyboard. The 82C110 synchronizes the internal keyboard logic with this signal. It sources the clock for the keyboard when sending serial data to the keyboard and receives the clock when the keyboard is sending data. If an external Model 25/30 style keyboard interface is used (and selected through the Internal Configuration Register), IRQ1 is the shared, active high Interrupt Request 1 input from the keyboard controller, pointing device, and real time clock.
100	B	KBDATA	<b>Keyboard Data.</b> KBDATA is an open drain bidirectional serial data to or from the keyboard. This line is unused if a Model 25/30 external keyboard interface is used.

**82C110 Pin Description (Continued)**

Pin No.	Pin Type	Symbol	Pin Description
70	O	SPKDATA	Speaker Data. SPKDATA should be buffered, and the output of the buffer should go through a low pass filter. The output of the filter connects to the speaker.
<b>Power and Grounds</b>			
2,26,78	—	V <sub>CC</sub>	Power Supply.
3,30,53,76	—	GND	Ground.
28,82	N/C		No Connect
5,27,89	RESERVED		These Pins Should Connect to GND

**Notes:**

1. The 82C110 provides four RAS signals to select which byte will be written. A single CAS and WE is provided for all banks.
2. PAR1 is provided for 16 bit 8086 systems with DRAM. Usage of this is determined by setting of the internal configuration registers.
3. BHE is provided for 8086 systems.
4. A packaged oscillator is assumed for the processor clock if the CPU clock is above 4.77MHz (14.318MHz/3).
5. The following explains the abbreviations used in the pin type/direction column.

Pin	Meaning
I	Input
B	Input and Output (3-state)
O	Output

### Functional Description

The 82C110 is a single chip VLSI implementation of most of the system logic for Enhanced or Super XT designs. It can also be used to build systems that are functional equivalents of the IBM Model 25/30, but with 100% XT compatibility. The device contains the equivalent of the 8288 Bus Controller, 8284 Clock Generator, 10 MHz 8237 DMA Controller, 8259 Interrupt Controller, 8255 Programmable Peripheral Interface, 8254 Programmable Interval Timer, Memory Controller, EMS Controller, and offers enhanced features such as Data Conversion Logic, Programmable Internal Configuration Registers, Programmable Wait States for Memory, I/O, and DMA, and Decoding Logic.

### SYSTEM CLOCK

The system clock circuit is functionally equivalent to the 8284 clock generator with the addition of logic to support 2 different clock frequencies. One is generated from the standard 14.318MHz crystal or oscillator. The other is optional and allows the processor and IO channel to operate at frequencies up to 10 MHz. This is generated by an external oscillator and must be 3 times the desired processor clock frequency (for example a 10 MHz CPU clock requires a 30 MHz oscillator). SYSCLK provides timing pulses at the maximum clock frequency.

All the system clock outputs are started when PWRGOOD is true (high). When PWRGOOD is false, all clock outputs are low.

### BUS CONTROLLER

The bus controller is functionally equivalent to the 8288 bus controller. It provides command generation and controls the timing of the internal bus and I/O channel, including logic for command delays (commands will be active at T3 instead of T2). The I/O channel timing is the same as the system timing—that is 10 MHz bus timing for 10 MHz systems. The wait states for memory, I/O and DMA cycles are programmable for flexibility. The bus controller module is enabled by SYSRST going high. As long as SYSRST is low, the

bus controller is inactive. For proper operation SYSRST should stay low for a minimum of 200 milliseconds after PWRGOOD is high.

### Local Bus Arbitration

The local processor bus is a multi-master bus and is shared between the CPU, numeric coprocessor, and the 82C110. Normally the CPU is the active bus master, but the other masters can force the CPU to release the local bus using the RQ/GT line. If the coprocessor is present (ICR 43H bit 3 is 1) the 82C110 uses RQ/GT1 for the bus exchange, otherwise it uses the RQ/GT0 line. Because of this, a co-processor can be installed or removed without the need for changing jumpers.

RQ/GT0 from the 82C110 should be connected to RQ/GT0 of the CPU. RQ/GT1 from the 82C110 should be connected to RQ/GT1 of the co-processor, and RQ/GT1 of the CPU to RQ/GT0 of the coprocessor.

The sequence of events on the RQ/GT lines is as follows:

1. Another bus master makes a bus request to the CPU by asserting a one clock wide pulse in any bus cycle on a RQ/GT line.
2. The CPU responds by asserting a pulse during T4 or T1, also one clock wide. This indicates to the requestor that the CPU will float the local bus and enter the "hold acknowledge" state in the next clock cycle, disconnecting the CPU from the local bus. The requestor now can take control of the bus.
3. When finished, the requesting master asserts another pulse to the CPU, and relinquishes control of the local bus at the next clock.

Each master to master bus exchange requires three pulses. After each bus exchange there must be one dead cycle for synchronizing purposes. Requests can occur when CPU is idle or during a memory cycle.

If a request is made during a memory cycle, the CPU releases control at T4 when the following conditions are met:

- a. Request occurs in or before T2
- b. Not executing a LOCKed instruction
- c. Not in the first INTA sequence
- d. Not in the first byte of a bus conversion cycle.

If request is made when CPU is idle, the CPU will:

- a. Release the bus on the next clock
- b. The DMA cycle will start within the next three clock cycles.

#### DMA CONTROLLER

The 82C110's DMA controller is functionally equivalent to the 8237 DMA controller. It has 4 DMA channels, address increment/decrement and masking of individual DMA requests. The DMA controller supports single, block, demand and memory to memory transfer modes. All DMA data transfers require 5 clock cycles per byte. The DMA controller does not support cascading.

DMA controller generates the memory address and control signals necessary to transfer information between a peripheral device and memory directly. Each DMA channel has a pair of 16-bit counters and a reload register for each counter. The 16-bit counters allow the DMA to transfer blocks as large as 65,536 bytes.

During normal operation, the DMA subsystem will be in either the Idle condition, the Program condition or the Active condition. In the Idle condition the DMA controller will be executing cycles consisting of only one state. The idle state S1 is the default condition and the DMA will remain in this condition unless the device

has been initialized and one of the DMA requests is active or the CPU attempts to access one of the internal registers.

When a DMA request becomes active the device enters the Active condition and issues a hold request to the system. Once in the Active condition the 82C110 will generate the necessary memory addresses and command signals to accomplish a memory-to-I/O, I/O-to-memory, or a memory-to-memory transfer. Memory-to-I/O and I/O-to-memory transfers take place in one cycle, while memory-to-memory transfers require two cycles. During transfers between memory and I/O, data is presented on the system bus by either memory or the requesting device and the transfer is completed in one cycle. Memory-to-memory transfers however, require the DMA to store data from the read operation in an internal register. The contents of this register is then written to memory on the subsequent cycle.

Due to the large number of internal registers in the DMA subsystem, an internal flip-flop is used to supplement the addressing of the count and address registers. This bit is used to select between the high and low bytes of these registers. The flip-flop will toggle each time a read or write occurs to any of the word count or address registers in the DMA. This internal flip-flop will be cleared by hardware RESET or a Master Clear command and may be set or cleared by the CPU issuing the appropriate command.

Figure 1 shows all the register information necessary to program the DMA controller. Special commands are supported by the DMA subsystem to control the device. These commands do not make use of the data bus, but are derived from a set of addresses, the internal select, read and write. These commands are Master Clear Register, Clear Mask Register, Clear Mode Register Counter, Set and Clear Byte Pointer Flip-Flop. These are discussed later.

ADDRESS OPERATION		Flip-Flop		Register Function
ADDRESS	READ	WRITE		
000h	0	1	0	Read Channel 0 Current Address Low Byte
	0	1	1	Read Channel 0 Current Address High Byte
	1	0	0	Write Channel 0 Base and Current Address Low Byte
	1	0	1	Write Channel 0 Base and Current Address High Byte
001h	0	1	0	Read Channel 0 Current Word Count Low Byte
	0	1	1	Read Channel 0 Current Word Count High Byte
	1	0	0	Write Channel 0 Base and Current Word Count Low Byte
	1	0	1	Write Channel 0 Base and Current Word Count High Byte
002h	0	1	0	Read Channel 1 Current Address Low Byte
	0	1	1	Read Channel 1 Current Address High Byte
	1	0	0	Write Channel 1 Base and Current Address Low Byte
	1	0	1	Write Channel 1 Base and Current Address High Byte
003h	0	1	0	Read Channel 1 Current Word Count Low Byte
	0	1	1	Read Channel 1 Current Word Count High Byte
	1	0	0	Write Channel 1 Base and Current Word Count Low Byte
	1	0	1	Write Channel 1 Base and Current Word Count High Byte
004h	0	1	0	Read Channel 2 Current Address Low Byte
	0	1	1	Read Channel 2 Current Address High Byte
	1	0	0	Write Channel 2 Base and Current Address Low Byte
	1	0	1	Write Channel 2 Base and Current Address High Byte
005h	0	1	0	Read Channel 2 Current Word Count Low Byte
	0	1	1	Read Channel 2 Current Word Count High Byte
	1	0	0	Write Channel 2 Base and Current Word Count Low Byte
	1	0	1	Write Channel 2 Base and Current Word Count High Byte
006h	0	1	0	Read Channel 3 Current Address Low Byte
	0	1	1	Read Channel 3 Current Address High Byte
	1	0	0	Write Channel 3 Base and Current Address Low Byte
	1	0	1	Write Channel 3 Base and Current Address High Byte
007h	0	1	0	Read Channel 3 Current Word Count Low Byte
	0	1	1	Read Channel 3 Current Word Count High Byte
	1	0	0	Write Channel 3 Base and Current Word Count Low Byte
	1	0	1	Write Channel 3 Base and Current Word Count High Byte
008h	0	1	X	Read Status Register
	1	0	X	Write Command Register
009h	0	1	X	Read DMA Request Register
	1	0	X	Write DMA Request Register
00Ah	0	1	X	Read Command Register
	1	0	X	Write Single Bit DMA Request Mask Register
00Bh	0	1	X	Read Mode Register
	1	0	X	Write Mode Register

Figure 1. DMA Registers

ADDRESS		OPERATION		Flip-Flop	Register Function
ADDRESS	READ	WRITE			
00Ch	0	1	X	X	Set Byte Pointer Flip-Flop
	1	0	X		Clear Byte Pointer Flip-Flop
00Dh	0	1	X	X	Read Temporary Register
	1	0	X		Master Clear
00Eh	0	1	X	X	Clear Mode Register Counter
	1	0	X		Clear All DMA Request Mask Register Bits
00Fh	0	1	X	X	Read All DMA Request Mask Register Bits
	1	0	X		Write All DMA Request Mask Register Bits

Figure 1. DMA Registers (continued)

**Register Description**

**Current Address Register**

Each DMA channel has a 16-bit Current Address Register which holds the address used during transfers. Each channel can be programmed to increment or decrement this register whenever a transfer is completed. This register can be read or written by the CPU in consecutive 8-bit bytes.

**Current Word Count Register**

Each channel has a Current Word Count Register which determines the number of transfers to perform. The actual number of transfers performed will be one greater than the value programmed into the register. The register is decremented after each transfer until it goes from zero to FFFFh. When this roll-over occurs the 82C110 will generate T/C.

**Base Address Register**

Associated with each Current Address Register is a Base Address Register. This is a write only register which is loaded by the CPU when writing to the Current Address Register. The purpose of this register is to store the initial value of the Current Address Register.

**Base Word Count Register**

This register preserves the initial value of the Current Word Count Register. It is also a write only register which is loaded by writing to the Current Word Count Register.

**Command Register**

This register controls the overall operation of a DMA subsystem. The register can be read or written by the CPU and is cleared by either RESET or a Master Clear command.

msb							lsb	
b7	b6	b5	b4	b3	b2	b1	b0	
DAK	DRQ	EW	RP	CT	CD	AH	M-M	

**DAK**—DACK active level is determined by bit 7. Programming a 1 in this bit position makes DACK an active high signal.

**DRQ**—DREQ active level is determined by bit 6. Writing a 1 in this bit position causes DREQ to become active low.

**EW**—Extended Write is enabled by writing a 1 to bit 5, causing the write commands to be asserted one DMA cycle earlier during a transfer.

**RP**—Writing a 1 to bit 4 causes the 82C110 to utilize a rotating priority scheme for honoring DMA requests. The default condition is fixed priority.

**CT**—Compressed timing is enabled by writing a 1 to bit 3 of this register. The default 0 condition causes the DMA to operate with normal timing.

**CD**—Bit 2 is the master disable for the DMA controller. Writing a 1 to this location disables the DMA subsystem. This function is normally used whenever the CPU needs to reprogram one of the channels to prevent DMA cycles from occurring.

**AH**—Writing a 1 to bit 1 enables the address hold feature in Channel 0 when performing memory-to-memory transfers.

**M-M**—A 1 in the bit 0 position enables Channel 0 and Channel 1 to be used for memory-to-memory transfers.

**Mode Register**

Each DMA channel has a Mode Register associated with it. All four Mode Registers reside at the same I/O address. Bits 0 and 1 of the Write Mode Register command determine which channel's Mode Register gets written. The remaining six bits control the mode of the selected channel. Each channel's Mode Register can be read by sequentially reading the Mode Register location. A Clear Mode Register Counter command is provided to allow the CPU to restart the mode read process at a known point. During mode read operations, bits 0 and 1 will both be 1.

msb						lsb	
b7	b6	b5	b4	b3	b2	b1	b0
M1	M0	DEC	AI	TT1	TT0	CS1	CS0
(Read/Write Register)							

**M1-M0**—Mode selection for each channel is accomplished by bits 6 and 7.

M1	M0	MODE
0	0	Demand Mode
0	1	Single Cycle Mode
1	0	Block Mode
1	1	Not Valid

**DEC**—Determines direction of the address counter. A one in bit 5 decrements the address after each transfer.

**AI**—The Autoinitialization function is enabled by writing a 1 in bit 4 of the Mode Register.

**TT1-TT0**—Bits 2 and 3 control the type of transfer which is to be performed.

TT1	TT0	TYPE
0	0	Verify Transfer
0	1	Write Transfer
1	0	Read Transfer
1	1	Illegal

**CS1-CS0**—Channel Select bits 1 and 0 determine which channel's Mode Register will be written. Read back of a mode register will result in bits 1 and 0 both being ones.

CS1	CS0	CHANNEL
0	0	Channel 0 select
0	1	Channel 1 select
1	0	Channel 2 select
1	1	Channel 3 select

**Request Register**

This is a four bit register used to generate software requests (DMA service can be requested either externally or under software control). Request Register bits can be set or reset independently by the CPU. The Request Mask has no effect on software generated requests. All four bits are read in one operation and appear in the lower four bits of the byte. Bits 4 through 7 are read as ones. All four request bits are cleared to zero by RESET.

msb						lsb	
b7	b6	b5	b4	b3	b2	b1	b0
X	X	X	X	X	RB	RS1	RS0
(Write Operation)							



**RB**—The request bit is set by writing a 1 to bit 2. RS1-RS0 select which bit (channel) is to be manipulated.

**RS1-RS0**—Channel Select 0 and 1 determine which channel's Mode Register will be written. Read back of the mode register will result in bits 0 and 1 both being ones.

RS1	RS0	CHANNEL
0	0	Channel 0 select
0	1	Channel 1 select
1	0	Channel 2 select
1	1	Channel 3 select

Format for the Request Register read operation is shown below.

msb							lsb
b7	b6	b5	b4	b3	b2	b1	b0
1	1	1	1	RC3	RC2	RC1	RC0

(Read Operation)

**RC3-RC0**—During a Request Register read, the state of the request bit associated with each channel is returned in bits 0 through 3 of the byte. The bit position corresponds to the channel number.

**Request Mask Register**

The Request mask register is a set of four bits which are used to inhibit external DMA requests from generating transfer cycles. This register can be programmed in two ways. Each channel can be independently masked by writing to the Write Single Mask Bit location. The data format for this operation is shown below.

msb							lsb	
b7	b6	b5	b4	b3	b2	b1	b0	
X	X	X	X	X	MB	MS1	MS0	

(Set/Reset Operation)

**MB**—Bit 2 sets or resets the request mask bit for the channel selected by MS1 and MS0. Writing a 1 in this bit position sets the mask, inhibiting external requests.

**MS1-MS0**—These two bits select the specific mask bit which is to be set or reset.

MS1	MS0	CHANNEL
0	0	Channel 0 select
0	1	Channel 1 select
1	0	Channel 2 select
1	1	Channel 3 select

Alternatively all four mask bits can be programmed in one operation by writing to the Write All Mask Bits address. Data format for this and the Read All Mask Bits function is shown below.

msb							lsb	
b7	b6	b5	b4	b3	b2	b1	b0	
X	X	X	X	MB3	MB2	MB1	MB0	

(Read/Writes Operation)

**MB3-MB0**—Each bit position in the field represents the mask bit of a channel. The mask bit number corresponds to the channel number associated with the mask bit.

All four mask bits are set following a RESET or a Master Clear command. Individual channel mask bits will be set as a result of terminal count being reached, if Autoinitialize is disabled. The entire register can be cleared, enabling all four channels, by performing a Clear Mask Register operation.

**Status Register**

The status of all four channels can be determined by reading the Status Register. Information is available to determine if a channel has reached terminal count and whether an external service request is pending. Bits 0-3 of this register are cleared by RESET, Master

Clear on each time a Status Read takes place. Bits 4-7 are cleared by RESET, Master Clear or the pending request being deasserted. Bits 4-7 are not affected by the state of the Mask Register Bits. The channel number corresponds to the bit position.

msb				lsb			
b7	b6	b5	b4	b3	b2	b1	b0
DRQ3	DRQ2	DRQ1	DRQ0	TC3	TC2	TC1	TC0

(Read Only Register)

**Temporary Register**

The Temporary Register is used as a temporary holding register for data during memory-to-memory transfers. The register is loaded during the first cycle of a memory-to-memory transfer from D0-D7. During the second cycle of the transfer, the data in the Temporary Register is output on the D0-D7 pins. Data from the last memory-to-memory transfer will remain in the register unless a RESET or Master Clear occurs.

**Special Commands**

Five Special Commands are provided to make the task of programming the device easier. These commands are activated as a result of a specific address and assertion of either a read or write. Information on the data lines is ignored by the 82C110 whenever an write activated command is issued, thus data returned on read activated commands is invalid.

**Clear Byte Pointer Flip-Flop**—This command is normally executed prior to reading or writing to the address or word count registers. This initializes the flip-flop to point to the low byte of the register and allows the CPU to read or write the register bytes in correct sequence.

**Set Byte Pointer Flip-Flop**—Setting the Byte Pointer Flip-Flop allows the CPU to adjust the pointer to the high byte of an address or word count register.

**Master Clear**—This command has the same effect as a hardware RESET. The Command

Register, Status Register, Request Register, Temporary Register, Mode Register Counter and Byte Pointer Flip-Flop are cleared and the Request Mask Register is set. Immediately following Master Clear or RESET, the DMA will be in the Idle Condition.

**Clear Request Mask Register**—This command enables all four DMA channels to accept requests by clearing the mask bits in the register.

**Clear Mode Register Counter**—In order to allow access to four Mode Registers while only using one address, an additional counter is used. After clearing the counter all four Mode Registers may be read by doing successive reads to the Read Mode Register address. The order in which the registers will be read is Channel 0 first, Channel 3 last.

**INTERRUPT CONTROLLER**

The interrupt controller is the functional equivalent of the 8259A plus additional logic. It supports one non-maskable (NMI) and eight maskable interrupt levels. Interrupt levels 2-7 are available at the system IO channel. When used with an XT-type keyboard, interrupt levels 0 and 1 are generated internal to the 82C110. Level 0 is the highest priority and it is connected to Counter/Timer channel 0 to provide a periodical interrupt for the timer tick. In an XT system, Level 1 is used for the keyboard and is connected internally to the keyboard interface. In a Model 25/30-type system, Level 1 is brought out to a pin and the interrupt must be generated by the external keyboard interface. It is shared by the keyboard, pointing device such as a mouse, and the real time clock; the sharing mechanism is handled by external hardware and the BIOS service routine through interrupt vector 71H.

The Interrupt Controller also handles Non Maskable interrupts coming from the Real Time Clock, Numeric CoProcessor, Power Failure Indicator, Parity Checker, and the IO Channel Check (IOCHCHK) signal. Since only one NMI pin exists on the processor, the NMI service routine reads a register to determine the source of the NMI.

Interrupt Assignments:

Level	System Board	I/O Channel
NMI	Parity Check	I/O Channel
	CoProcessor	Check
	Real Time Clock	
	Power Failure	
IRQ0	Timer Channel 0	Not Available
IRQ1	Keyboard	Not Available
	Pointing Device (opt)	
	Real Time Clock (opt)	
IRQ2	Video	Available
IRQ3	Not Used	Available
IRQ4	Serial Port	Available
IRQ5	Hard Disk	Available
IRQ6	Floppy Disk	Available
IRQ7	Parallel Port	Available

Figure 2 is a block diagram of the major elements in the interrupt controller. The Interrupt Request Register (IRR) is used to store requests from all of the channels which are requesting service. Interrupt Request Register bits are labeled using the Channel Name IR7-IR0. The In-Service Register (ISR) contains all the channels which are currently being serviced (more than one channel can be in service at a time). In-Service Register bits are labeled IS7-IS0 and correspond to IR7-IR0. The Interrupt Mask Register (IMR) allows the CPU to disable any or all of the interrupt channels. The Priority Resolver evaluates inputs from the above three registers, issues an interrupt request, and latches the corresponding bit into the In-Service Register. The contents of the Vector Register are used to provide the CPU with an interrupt vector during Interrupt Acknowledge (INTA) cycles.

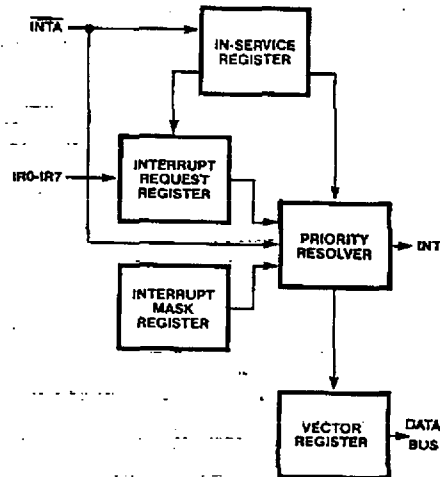

Figure 2. Interrupt Controller Block Diagram

Two types of commands are used to control the 82C110 interrupt controllers, Initialization Command Words (ICWs) and Operational Command Words (OCWs).

Initialization Command Words

The initialization process consists of writing a sequence of 3 bytes to the interrupt controller. The initialization sequence is started by writing the first Initialization Command Word (ICW1) to address 020H with a 1 on bit 4 of the data byte. The interrupt controller interprets this as the start of an initialization sequence and does the following:

- 1—The Initialization Command Word Counter is reset to zero.
- 2—ICW1 is latched into the device
- 3—Fixed Priority Mode is selected
- 4—IR7 is assigned the highest priority
- 5—The Interrupt Mask Register is cleared
- 6—The Slave Mode Address is set to 7
- 7—Special Mask Mode is disabled
- 8—The IRR is selected for Status Read operations

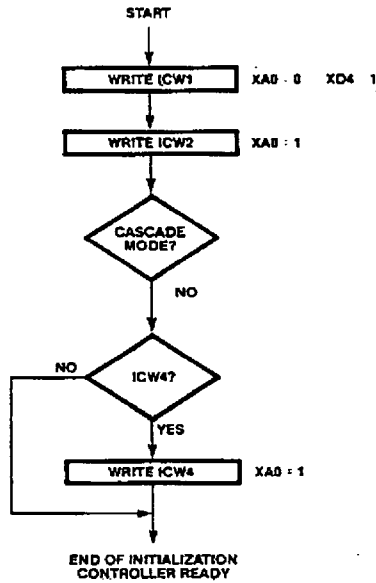

Figure 3. Initialization Sequence

The next two I/O writes to address 021H will load ICW2 and ICW4. See Figure 3 for a flow chart of the initialization sequence. The initialization sequence can be terminated at any point (all 3 bytes must be written for the controller to be properly initialized) by writing to address 020H with a 0 in data bit 4. Note, this will cause OCW2 to be written.

ICW1—Address 020H

msb							lsb
b7	b6	b5	b4	b3	b2	b1	b0
X	X	X	SI	LTM	X	SM	IC4

(Write Only Register)

SI—Bit 4 indicates to the interrupt controller that an Initialization Sequence is starting and must be a 1 to write ICW1.

LTM—Bit 3 selects level or edge triggered inputs to the IRR.

SM—Bit 1 selects between Single Mode and Cascade Mode.

IC4—Bit 0 selects ICW4 needed or not needed.

ICW2—Address 021H

msb					lsb		
b7	b6	b5	b4	b3	b2	b1	b0
V7	V6	V5	V4	V3	X	X	X

(Write Only Register)

V7-V3—These bits are the upper 5 bits of the interrupt vector and are programmable by the CPU. The lower three bits of the vector are generated by the Priority Resolver during INTA.

ICW4—Address 021H

msb							lsb
b7	b6	b5	b4	b3	b2	b1	b0
X	X	X	EMI	X	X	AEOI	X

(Write Only Register)

EMI—Bit 4 will Enable Multiple Interrupts from the same channel in Fixed Priority Mode.

**AEOI**—Auto End Of Interrupt is enabled when ICW4 is written with a one in bit 1. The interrupt controller will perform a non-specific EOI on the trailing edge of the second INTA cycle.

**Operational Command Words**

Operational Command Words (OCWs) allow the 82C110 interrupt controller to be controlled or reconfigured at any time while operating. Each interrupt has 3 OCWs which can be programmed to affect the proper operating configuration and a Status Register to monitor controller operation.

Operational Command Word 1 (OCW1) is located at address 021h and may be written any time the controller is not in Initialization Mode. Operational Command Words 2 and 3 (OCW2, OCW3) are located at address 020h. Writing to address 020h with a 0 in bit 4 will place the controller in operational mode and load OCW2 (if data bit 3 = 0) or OCW3 (if data bit 3 = 1).

**OCW1**—Address 021H

msb							lsb		
b7	b6	b5	b4	b3	b2	b1	b0		
M7	M6	M5	M4	M3	M2	M1	M0		

(Read/Write Register)

**M7-M0**—These bits control the state of the Interrupt Mask Register. Each Interrupt Request can be masked by writing a 1 in the appropriate bit position (M0 controls IR0 etc.). Setting an IMR bit has no affect on lower priority requests. All IMR bits are cleared by writing ICW1.

**OCW2**—Address 020h

msb							lsb		
b7	b6	b5	b4	b3	b2	b1	b0		
R	SL	EOI	SI	2/3	L2	L1	L0		

(Write Only Register)

**R**—This bit in conjunction with SL and EOI selects operational function. Writing a 1 in bit 7 causes one of the rotate functions to be selected.

R	SL	EOI	Function
1	0	0	Rotate on auto EOI enable*
1	0	1	Rotate on non-specific EOI
1	1	0	Specific Rotate Command
1	1	1	Rotate on specific EOI

\*This function is disabled by writing a zero to all three bit positions.

**SL**—This bit in conjunction with R and EOI selects operational function. Writing a 1 in this bit position causes a specific or immediate function to occur. All specific commands require L2-L0 to be valid except no operation.

R	SL	EOI	Function
0	1	0	No operation
0	1	1	Specific EOI Command
1	1	0	Specific Rotate Command
1	1	1	Rotate on specific EOI

**EOI**—This bit in conjunction with R and SL selects operational function. Writing a 1 in this bit position causes a function related to EOI to occur.

R	SL	EOI	Function
0	0	1	Non-specific EOI Command
0	1	1	Specific EOI Command
1	0	1	Rotate on non-specific EOI
1	1	1	Rotate on specific EOI

**SI**—Writing a 0 in this bit position takes the interrupt controller out of initialize mode and writes OCW2 or OCW3.

**2/3**—If the I/O write places a 0 in bit 4 (SI), then writing a 0 in bit 3 (2/3) selects OCW2 and writing a 1 will select OCW3.

**L2-L0**—These three bits are internally decoded to select which Interrupt channel is to be affected by the Specific command. L2-L0 must be valid during three of the four specific cycles (see SL above).

**OCW3**—Address 020H

msb								lsb
b7	b6	b5	b4	b3	b2	b1	b0	
0	ESMM	SMM	SI	2/3	PM	RR	RIS	

(Write Only Register)

**ESMM**—Writing a 1 in this bit position enables the Set/Reset Special Mask Mode function controlled by bit 5 (SMM). ESMM allows the other functions in OCW3 to be accessed and manipulated without affecting the Special Mask Mode state.

**SMM**—If ESMM and SMM both are written with a 1 the Special Mask Mode is enabled. Writing a 1 to ESMM and a 0 to SMM disables Special Mask Mode. During Special Mask Mode, writing a 1 to any bit position inhibits interrupts and a 0 enables interrupts on the associated channel by causing the Priority Resolver to ignore the condition of the ISR.

**SI**—See SI above.

**2/3**—See 2/3 above.

**PM**—Polled Mode is enabled by writing a 1 to bit 2 of OCW3, causing the 82C110 to perform the equivalent of an INTA cycle during the next I/O read operation to the controller. The byte read during this cycle will have bit 7 set if an interrupt is pending. If bit 7 of the byte is set, the level of the highest pending request will be encoded on bits 2-0. The IRR will remain frozen until the read cycle is completed at which time the PM bit is reset.

**RR**—When the RR bit (bit 1) is 1, reading the Status Port at address 020h will cause the contents of IRR or ISR (determined by RIS) to be placed on D7-D0. Asserting PM forces RR reset.

**RIS**—This bit selects between the IRR and the ISR during Status Read operations if RR = 1.

### Interrupt Sharing

Interrupt Sharing allows more than one device to use a single interrupt level. In a Model 25/30, the keyboard, pointing device and real-time-clock all share the same interrupt level. In a Model 25/30 look-alike design, a keyboard/mouse interface that emulates IBM's implementation must be done with external hardware. In the 82C110's "PS/2" keyboard mode, the IRQ1 line is an input driven by the external keyboard/mouse interface. The external circuit must insure that if multiple interrupt requests are pending, the interrupt line must return to the inactive (low) state after each interrupt is serviced. This will insure that the interrupt controller in the 82C110 sees a rising edge for each interrupt, otherwise the request will be lost.

### TIMER

The timer circuit is functionally equivalent to the 8254 timer. Channel 0 is used as a general-purpose and software interrupt timer. Channel 1 is unused, and channel 2 is used to support tone generation for the audio speaker. The timer channel clock rate, referred to as TMRCLK in rest of the explanation, is derived by dividing a 4.77 MHz clock by 4. Each channel has a minimum timing resolution of 840ns.

The Counter/Timer (CTC) in the 82C110 is general purpose, and can be used to generate accurate time delays under software control. The CTC contains 3 16-bit counters (Counter 0-2) which can be programmed to count in binary or binary coded decimal (BCD). Each counter operates independently of the other two and can be programmed for operation as a timer or a counter.

All three of the counters shown in Figure 4 are controlled from a common set of control logic. The Control Logic decodes control information written to the CTC and provides the controls necessary to load, read, configure and control each counter. Counter 0 and Counter 1 can be programmed for all six modes, but Mode 1 and Mode 5 have limited usefulness due to the lack of an external hardware trigger signal. Counter 2 can be operated in any of six modes listed below.

- Mode 0 Interrupt on terminal count
- Mode 1 Hardware retriggerable one-shot
- Mode 2 Rate generator
- Mode 3 Square wave generator
- Mode 4 Software triggered strobe
- Mode 5 Hardware retriggerable strobe

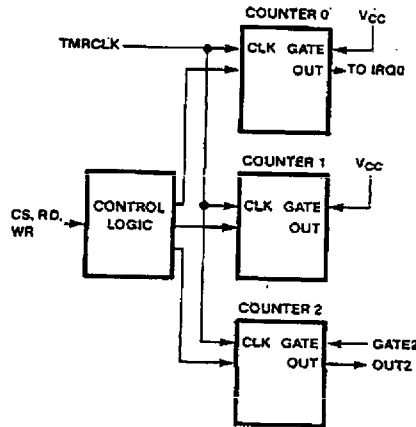

Figure 4. Counter/Timer Block Diagram

**Counter Description**

Each counter in the CTC contains a Control Register, a Status Register, a 16-bit Counting Element (CE), a pair of 8-bit Counter Input Latches (CIL, CIH), and a pair of 8-bit Counter Output Latches (COL, COH).

The Control Register stores the mode and command information used to control the counter. The Control Register may be loaded by writing a byte, containing a pointer to the desired counter, to the Write Control Word address (043h). The remaining bits in the byte contain the mode, the type of command, and count format information.

The Status register allows the software to monitor counter condition and read back the contents of the Control Register.

The Counting Element is a loadable 16-bit synchronous down counter. The CE is loaded or decremented on the falling edge of TMRCLK. The CE contains the maximum count when a 0 is loaded; which is equivalent to 65536 in binary operation or 10000 in BCD. The CE does not stop when it reaches 0. In Modes 2 and 3 the CE will be reloaded and in all other modes it will wrap around to FFFF in binary operation or 9999 in BCD.

The CE is indirectly loaded by writing one or two bytes (optional) to the Counter Input Latches, which are in turn loaded into the CE. This allows the CE to be loaded or reloaded in one TMRCLK cycle.

The CE is also read indirectly by reading the contents of the Counter Output Latches. COL and COH are transparent latches which can be read while transparent or latched (see Latch Counter Command).

**Programming The CTC**

After power-up the condition of CTC Control Registers, counter registers, CE, and the output of all counters is undefined. Each counter must be programmed before it can be used.

Counters are programmed by writing a Control Word and then an initial count. The Control Register of a counter is written by writing to the Control Word address (see Figure 5). The Control Word is a write only location.

Address	Function
040h	Counter 0 Read/Write
041h	Counter 1 Read/Write
042h	Counter 2 Read/Write
043h	Control Register Write Only

Figure 5. Counter/Timer Address Map

**M2-M0**—Bits 3-1 determine the counter's mode during Read/Write Counter Commands (see Read/Write Counter Command) or select the counter during a Read-Back Command (see Read-Back Command). Bits 3-1 become "don't care" during Latch Counter Commands.

Control Word—(043H)

msb								lsb
b7	b6	b5	b4	b3	b2	b1	b0	
F3	F2	F1	F0	M2	M1	M0	BCD	

(Write Only Register)

**F3-F0**—Bits 7-4 determine the command to be performed.

**BCD**—Bit 0 selects binary coded decimal counting format during Read/Write Counter Commands. Note, during Read-Back Command this bit must be 0.

**Read/Write Counter Command**

When writing to a counter, two conventions must be observed:

- 1—Each counter's Control Word must be written before the initial count is written.
- 2—Writing the initial count must follow the format specified in the Control Word (least significant byte only, most significant byte only, or least significant byte and then most significant byte).

A new initial count can be written into the counter at any time after programming without rewriting the Control Word providing the programmed format is observed.

During Read/Write Counter Commands M2-M0 are defined as follows:

F3	F2	F1	F0	Command
0	0	0	0	Latch Counter 0 (see Counter Latch Command)
0	0	0	1	Read/Write Counter 0 LSB Only
0	0	1	0	Read/Write Counter 0 MSB Only
0	0	1	1	Read/Write Counter 0 LSB then MSB
0	1	0	0	Latch Counter 1 (see Counter Latch Command)
0	1	0	1	Read/Write Counter 1 LSB Only
0	1	1	0	Read/Write Counter 1 MSB Only
0	1	1	1	Read/Write Counter 1 LSB then MSB
1	0	0	0	Latch Counter 2 (see Counter Latch Command)
1	0	0	1	Read/Write Counter 2 LSB Only
1	0	1	0	Read/Write Counter 2 MSB Only
1	0	1	1	Read/Write Counter 2 LSB then MSB
1	1	X	X	Read-Back Command (see Counter Read-Back Command)

MSB = most significant byte  
LSB = least significant byte



M2	M1	M0	Function
0	0	0	Select Mode 0
0	0	1	Select Mode 1
X	1	0	Select Mode 2
X	1	1	Select Mode 3
1	1	0	Select Mode 4
1	1	1	Select Mode 5

**Latch Counter Command**

When a Latch Counter Command is issued, the counter's output latches (COL, COH) latch the current state of the CE. COL and COH remain latched until read by the CPU, or the counter is reprogrammed. The output latches then return to a "transparent" condition. In this condition the latches are enabled and the contents of the CE may be read directly.

Latch Counter Commands may be issued to more than one counter before reading the first counter to which the command was issued. Also, multiple Latch Counter Commands issued to the same counter without reading the counter will cause all but the first command to be ignored.

**Read-Back Command**

The Read-Back Command allows the user to check the count value, Mode, and state of the OUT signal and Null Count Flag of the selected counter(s).

The format of the Read-Back Command is:

msb								lsb	
b7	b6	b5	b4	b3	b2	b1	b0		
1	1	LC	LS	C2	C1	C0	0		

**LC**—Writing a 0 in bit 5 causes the selected counter(s) to latch the state of the CE in COL and COH.

**LS**—Writing a 0 in bit 4 causes the selected counter(s) to latch the current condition of its Control Register, Null Count and Output into the Status Register. The next read of the Counter will result in the contents of the Status Register being read (see Status Read).

**C2-C0**—Writing a 1 in bit 3 causes Counter 3 to latch one or both of the registers specified by LC and LS. The same is true for bits 2 and 1 except that they enable Counters 1 and 0 respectively.

Each counter's latches remain latched until either the latch is read or the counter is reprogrammed.

If LS = LC = 0, status will be returned on the next read from the counter. The next one or two reads (depending on whether the counter is programmed to transfer one or two bytes) from the counter result in the count being returned.

**Status Byte**

msb							lsb		
b7	b6	b5	b4	b3	b2	b1	b0		
OUT	NC	F1	F0	M2	M1	M0	BCD		

**OUT**—Bit 7 contains the state of the OUT signal of the counter

**NC**—Bit 6 contains the condition of the Null Count Flag. This flag is used to indicate that the contents of the CE are valid. NC will be set to a 1 during a write to the Control Register or the counter. NC is cleared to a 0 whenever the counter is loaded from the counter input registers.

**F1-F0**—Bits 5-4 contain the F1 and F0 Command bits which were written to the Command Register of the counter during initialization. This information is useful in determining whether the high byte, the low byte or both must be transferred during counter read/write operations.

**M2-M0**—These bits reflect the mode of the counter and are interpreted in the same manner as in Write Command operations.

**BCD**—Bit 0 indicates the CE is operating in BCD format.

#### Counter Operation

Due to the previously stated restrictions in Counter 0 and Counter 1, Counter 2 will be used as the example in describing counter operation, but the description of Mode 0, 2, 3 and 4 is relevant to all counters.

The following terms are defined for describing CTC operation.

**TMCLK pulse**—A rising edge followed by a falling edge of the TMCLK.

**trigger**—The rising edge of the GATE2 input.  
**counter load**—The transfer of the 16-bit value in CIL and CIH to the CE.

**initialized**—A Control Word written and the Counter Input Latches loaded.

Counter 2 operates in one of the following modes.

#### Mode 0—Interrupt on terminal count

Writing the Control Word causes OUT2 to go low and remain low until the CE reaches 0, at which time it goes back high and remains high until a new count or Control Word is written. Counting is enabled when GATE2 = 1. Disabling the count has no effect on OUT2.

The CE is loaded with the first TMCLK pulse after the Control Word and initial count are loaded. When both CIL and CIH are written, the CE is loaded after CIH is written (see Write Operations). This TMCLK pulse does not decrement the count, so for an initial count of N, OUT2 does not go high until N+1 TMCLK pulses after initialization. Writing a new initial count to the counter reloads the CE on the next TMCLK pulse and counting continues from the new count.

If an initial count is written with GATE2 = 0, it will still be loaded on the next TMCLK pulse but counting does not begin until GATE2 = 1. OUT2 therefore, goes high N TMCLK pulses after GATE2 = 1.

#### Mode 1—Hardware retriggerable one-shot

Writing the Control Word causes OUT2 to go high initially. Once initialized the counter is armed and a trigger causes OUT2 to go low on the next TMCLK pulse. OUT2 then remains low until the counter reaches 0. An initial count of N results in a one-shot pulse N TMCLK cycles long.

Any subsequent triggers while OUT2 is low cause the CE to be reloaded, extending the length of the pulse. Writing a new count to CIL and CIH will not affect the current one-shot unless the counter is retriggered.

#### Mode 2—Rate generator

Mode 2 functions as a divide-by-N counter, with OUT2 as the carry. Writing the Control Word during initialization sets OUT2 high.

When the initial count is decremented to 1, OUT2 goes low on the next TMCLK pulse. The following TMCLK pulse returns OUT2 high, reloads the CE and the process is repeated. In Mode 2 the counter continues counting (if GATE2 = 1) and will generate an OUT2 pulse every N TMCLK cycles. Note that a count of 1 is illegal in Mode 2.

**GATE2 = 0** disables counting and forces OUT2 high immediately. A trigger reloads the CE on the next TMCLK pulse. Thus GATE2 can be used to synchronize the counter to external events.

Writing a new count while counting does not affect current operation unless a trigger is received. Otherwise, the new count will be loaded at the end of the current counting cycle.

**Mode 3—Square wave generator**

Mode 3 is similar to Mode 2 in every respect except for the duty cycle of OUT2. OUT2 is set high initially and remains high for the first half of the count. When the first half of the initial count expires, OUT2 goes low for the remainder of the count.

If the counter is loaded with an even count, the duty cycle of OUT2 will be 50% (high = low = N/2). For odd count values, OUT2 is high one TMRCLK cycle longer than it is low. Therefore, high = (N+1)/2 and low = (N-1)/2.

**Mode 4—Software triggered strobe**

Writing the Control Word causes OUT2 to go high initially. Expiration of the initial count causes OUT2 to go low for one TMRCLK cycle. GATE2 = 0 disables counting but has no effect on OUT2. Also, a trigger will not reload the CE.

The counting sequence is started by writing the initial count. The CE is loaded on the TMRCLK pulse after initialization. The CE begins decrementing one TMRCLK pulse later. OUT2 will go low for one TMRCLK cycle, (N+1) cycles after the initial count is written.

If a new initial count is written during a counting sequence, it is loaded into the CE on the next TMRCLK pulse and the sequence continues from the new count. This allows the sequence to be "retriggerable" by software.

**Mode 5—Hardware triggered strobe**

Writing the Control Word causes OUT2 to go high initially. Counting is started by trigger. The expiration of the initial count causes OUT2 to go low for one TMRCLK cycle. GATE2 = 0 disables counting.

The CE is loaded on the TMRCLK pulse after a trigger. Since loading the CE inhibits decrementing, OUT2 will go low for one TMRCLK cycle, (N+1) TMRCLK cycles after the trigger.

If a new count is loaded during counting, the current counting sequence will not be affected unless a trigger occurs. A trigger causes the counter to be reloaded from CIL and CIH, making the counter "retriggerable".

**GATE2**

In Modes 0, 2, 3 and 4 GATE2 is level sensitive and is sampled on the rising edge of TMRCLK. In Modes 1, 2, 3 and 5 the GATE2

Mode	Condition		
	Low	Rising	High
0	Disables Counting	—	Enables Counting
1	—	a) Initiates Counting b) Resets Out Pin	—
2	a) Disables Counting b) Forces Out Pin High	Initiates Counting	Enables Counting
3	a) Disables Counting b) Forces Out Pin High	Initiates Counting	Enables Counting
4	Disables Counting	—	Enables Counting
5	—	Initiates Counting	—

Figure 6. Gate Pin Function

input is rising-edge sensitive. This rising edge sets an internal flip-flop whose output is sampled on the next rising edge of TMRCLK. The flop-flop resets immediately after being sampled. Note that in Modes 2 and 3 the GATE2 input is both edge and level sensitive.

**PROGRAMMABLE PERIPHERAL INTERFACE (PPI)**

The 82C110 PPI is a subset of the 8255. It has all the four registers, but it is limited to mode 0 (basic input/output). No handshake is required when data is read from or written to a specific port. I/O address 60H is referred as port A, 61H is port B and 62H is port C.

The programming is similar to that of the 8255 PPI, but the external interface is different. Some of the bits are internal and hardwired so they cannot be changed.

The input portion of port A (60H) is for the keyboard scan code (if an XT-type keyboard is being used). If a PS/2 type keyboard is being used (selected by a bit in the configuration registers) Port A (60H) is disabled so that it may be implemented externally. Port B (61H) is the control port and port C (62H) is the status port for various system functions described below. Port 63H is the command/mode register for these three I/O ports. In the normal operation of the PC/XT, the control word is programmed to 99H: Port A (60H), and port C (62H) are inputs, and port B (61H) is output.

**To Program the PPI:**

1. Select the desired operational modes for both group A and group B, by selecting the appropriate combination of bits 6:5, and bit 2.
2. Bit 7 should be 1 to select the Mode Set function.
3. Select the grouping of inputs and outputs (bits 0, 1, 3, and 4)
4. Write the Mode Control word to port 63H.

**Single Bit Set/Reset Mode**

Any of the bits in port C can be Set/Reset using a single OUT instruction. To Set/Reset any Port C bits:

1. Select the bit to be set/reset (bits 3:1).
2. Select bit 0 for set (1) or reset (0).
3. Set bit 7 to 0 to select the Single Bit mode.
4. Write the control word to port 63H.

**Parallel Port Bit Definition**

**Port A (60H) - R (XT Keyboard Mode Only)**  
R-Keyboard Scan Code

**Port B (61H) - W**

bit 7	KBEN, Keyboard enable/clear. Clear port 60 and generate keyboard clear NMI if port 72, bit 6 is set. 0 - Enable Keyboard. (Default) 1 - Clear Keyboard.
bit 6	KBCLKLO, Keyboard Clock Low. For XT keyboards only. 0 - Hold Keyboard Clock Low. 1 - Normal Keyboard Clock. (Default)
bit 5	IOCHCKEN, I/O Channel Check Enable. 0 - Enable I/O Channel Check. Default. 1 - Disable I/O Channel Check. (Default)
bit 4	PCKEN, Parity Check Enable. 0 - Enable Parity Check. (Default) 1 - Disable Parity Check.
bit 3	Read High/Low Switches 0 - Low Nibble Switches 1 - High Nibble Switches (Default)
bit 2	Reserved.

- bit 1 **SPKDATA - Speaker Data**  
 0 - Disable Speaker Data, SPKDATA output (pin 70) will remain LOW.  
 1 - Enable Speaker Data. (Default)

---

- bit 0 **TMR2GTSPK - Timer 2 Gate Speaker Controls the Gate 2 input of the timer.**  
 0 - Stop count of timer 2. If SPKDATA bit (bit 1) is set to HIGH then SPKDATA output (pin 70) will be HIGH, else it will be LOW. (Default)  
 1 - Enable counting of timer 2.

**Port C (62H) - R**

Note: The lower nibble of Port C is used to read the configuration DIP switches present in an XT system. The switches are read as two groups of four. The high group is read when bit 3 of Port B is high and the low group is read when bit 3 of Port B is low. In a system with the 82C110, these switches do not physically exist. They are emulated by a configuration register. They are provided for software compatibility only. The values listed here are those used by IBM in the latest XT, however they don't actually control anything. Note that bits 0, 2, 3 and 4 have been redefined in the Model 25/30. Since these bits are just values and do not actually control any hardware, a Model 25/30 compatible BIOS could use these bits as they are defined by the Model 25/30 instead of the XT definitions.

**Low Switches**

- bit 2:3 **Planar Ram Size.**  
 00 - 256K  
 01 - 512K  
 10 - 576K  
 11 - 640K

---

- bit 1 **Co-Processor Installed**  
 0 - No coprocessor.  
 1 - Coprocessor is installed.

- bit 0 **Loop on POST**  
 0 - Do not loop on POST  
 1 - Loop on POST, if any of the POST routine fails - used for diagnostic purposes.

**High Switches**

- bit 7 **RAM Parity Check**  
 0 - No parity error has occurred.  
 1 - Parity error on the mother board RAM has occurred.

---

- bit 6 **I/O Channel Check**  
 0 - I/O CH CK line is inactive.  
 1 - I/O CH CK line is active - error occurred.

---

- bit 5 **Timer Channel 2 Out**  
 Status of Timer Channel 2 output. When this bit does not change status, timer channel 2 is not working, because:  
 a. TMR2GTSPK is disabled and/or  
 b. channel 2 has not correctly been programmed.

---

- bit 4 **Reserved.**

---

- bits 2:3 **Number of Diskette Drives**  
 00 - 1 Drive  
 01 - 2 Drives  
 10 - 3 Drives  
 11 - 4 Drives

---

- bits 0:1 **Display Type at Power-up**  
 00 - EGA  
 01 - CGA 40x25  
 10 - CGA 80x25  
 11 - Monochrome 80x25

**Port 63H (R/W) - Mode Set Definition**

- bit 7 **Mode Select**  
 (0 - Single Bit Set/Reset mode—see below)  
 1 - Mode Set Function

bits 6:5 Mode Selection for Group A	
	00 - Mode 0 01 - Mode 1 1X - Mode 2
bit 4	Port A mode (Group A) 0 - Output 1 - Input
bit 3	Port C Upper Nibble (Group A) 0 - Output 1 - Input
bit 2	Group B Mode Select 0 - Mode 0 1 - Mode 1
bit 1	Port B (Group B) 0 - Output 1 - Input
bit 0	Port A Lower Nibble (Group B) 0 - Output 1 - Input
<b>Port 63H (R/W) - Single Bit Set/Reset Mode</b>	
bit 7	Mode Select 0 - Single Bit Set/Reset Mode (1 - Mode Set Function—see above)
bit 6:4	Don't Care
bit 3:1	Bit Select 000 - Bit 0 001 - Bit 1 010 - Bit 2 011 - Bit 3 100 - Bit 4 101 - Bit 5 110 - Bit 6 111 - Bit 7
bit 0	Set/Reset 0 - Reset 1 - Set

**KEYBOARD INTERFACE**

The keyboard interface makes provisions to bypass the internal logic so a PS/2 style keyboard may be used. Selection is done through the Internal Configuration Registers. When this option is selected, Port 60H is essentially turned off so that it may be implemented externally.

KBDATA and KBCLK are open collector and are both input and output when using an XT keyboard. KBDATA is unused and KBCLK becomes the IRQ1 input when the 82C110 is used in PS/2 keyboard mode.

In XT Keyboard mode, the interface logic assembles the serial data from the keyboard into bytes. Timing and synchronization is provided by the KBCLK signal. Internally there are shift registers clocked by KBCLK.

**To Receive Characters:**

When a key is depressed or released, the keyboard controller sends a scan code. The keyboard logic assembles the incoming serial data to a byte. Whenever a byte of information is ready, an IRQ1 is sent to the interrupt controller. The IRQ1 interrupt service routine reads port 60H to get the keyboard scan code and acknowledges by sending a positive pulse on port 61H, this clears the shift register for the next character.

**MEMORY INTERFACE**

The 82C110 has a powerful memory controller. It generates the control signals for dynamic RAMs and the BIOS ROM.

The DRAM control function has an independent DRAM refresh timer that can be programmed to generate a refresh rate from 838ns to 214µs. It also generates all the necessary timings and controls for 4 banks of DRAM arrays. The signals are RAS0, CAS, WE, and the multiplexed addresses MA0-MA9 during refresh and memory accesses.

ROMCS is used to select the ROM BIOS. It is decoded for address range F000H:FFFFH.

### ROM Interface

$\overline{ROMCS}$  is active low for the 64K address range F0000 to FFFFF, qualified with  $\overline{MEMR}$ .  $\overline{ROMCS}$  should be connected to the Output Enable ( $\overline{OE}$ ) of the ROM, and the Chip Enable ( $\overline{CE}$ ) should be tied to ground. Two ROMs would be used in a 16 bit system, and one ROM would be used in an 8 bit system.

### Dynamic RAM Interface

The memory configuration on the system board is defined in the configuration registers. Four bits are used to select one of the sixteen predefined configurations from 128KB to 2.5MB, 8 bit or 16 bit. Connections to the DRAMs are simplified, because all the control and timing signals are generated by the 82C110. The 82C110 generates RAS, CAS,  $\overline{WE}$  and all addresses. CPU commands are active at the beginning of T2. Memory cycles

are divided into 3 segments for timing generation. At 1/3 of T2 RAS is active, at 2/3 of T2 the DRAM address is multiplexed and  $\overline{WE}$  is active (if a write cycle), and CAS is active at the end of T2 (at beginning of T3). Commands are inactive at T4, whereas DRAM controls are inactive at 1/3 of T4 to account for data hold time.

Address translations for LIM EMS are internal. The value in the EMS register is combined with the lower address bits to make the complete DRAM address.

The following table shows the actual address bits present on the multiplexed address (MA) lines for RAS and CAS cycles for 8 and 16 bit memory modes depending on the type of memory device used.

### 8 Bit Memory Configuration

MA Outputs	09	08	07	06	05	04	03	02	01	00
RAS (All devices)	09	08	07	06	05	04	03	02	01	00
CAS (64K devices)	—	—	09	10	15	14	13	12	11	08
CAS (256K devices)	—	16	17	10	15	14	13	12	11	09
CAS (1M devices)	18	16	17	10	15	14	13	12	11	19

### 16 Bit Memory Configuration

MA Outputs	09	08	07	06	05	04	03	02	01	00
RAS (All devices)	09	08	07	06	05	04	03	02	01	10
CAS (64K devices)	18	16	09	10	15	14	13	12	11	—
CAS (256K devices)	18	16	17	10	15	14	13	12	11	—
CAS (1M devices)	18	16	17	20	15	14	13	12	11	19

Use note that in the following table the device size refers to the address width, not necessarily the number of bits per device. For example, two 256Kx4 DRAMs could be used instead of eight 256Kx1 devices to give the same amount of memory. Although the 256Kx4 devices contain 1 megabit, they are connected and treated in the memory configuration register as a 256K device.

The following describes which MA lines to connect to the DRAMs for both 8 and 16 bit devices:

For 8 bit configurations:

- 64K devices Use MA0-7
- 256K devices Use MA0-8
- 1M devices Use MA0-9

For 16 bit configurations:

- 64K Devices Use MA1-8
- 256K Devices Use MA1-9
- 1M Devices Use MA0-9

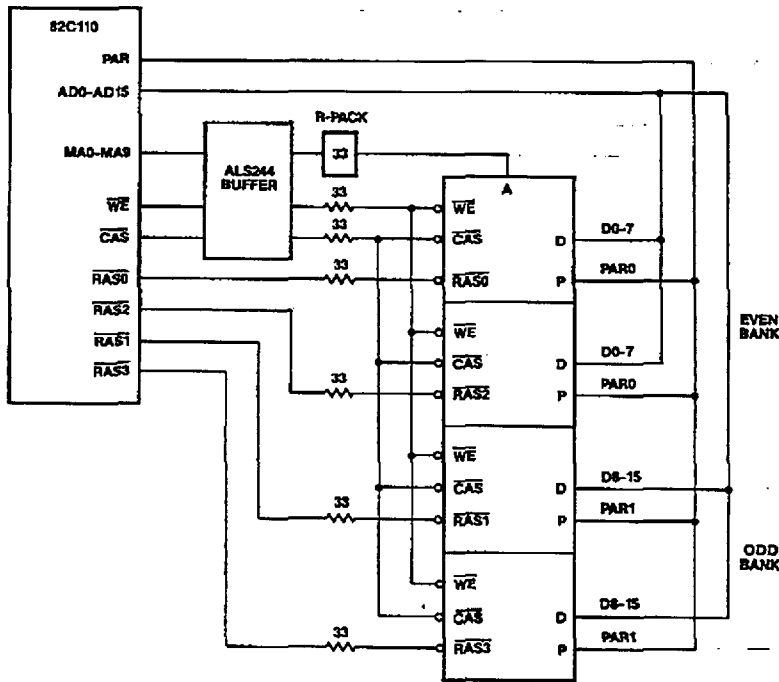

NOTE: MA0-MA9, WE, CAS, RAS0-RAS3 ARE CAPABLE OF DRIVING UP TO 9 DRAM LOADS WITHOUT EXTERNAL BUFFER, ASSUMING DRAM  $t_{CL}$  IS 10µA PER LOAD, AND  $C_L = 7pF/LOAD$

16-Bit DRAM Interface



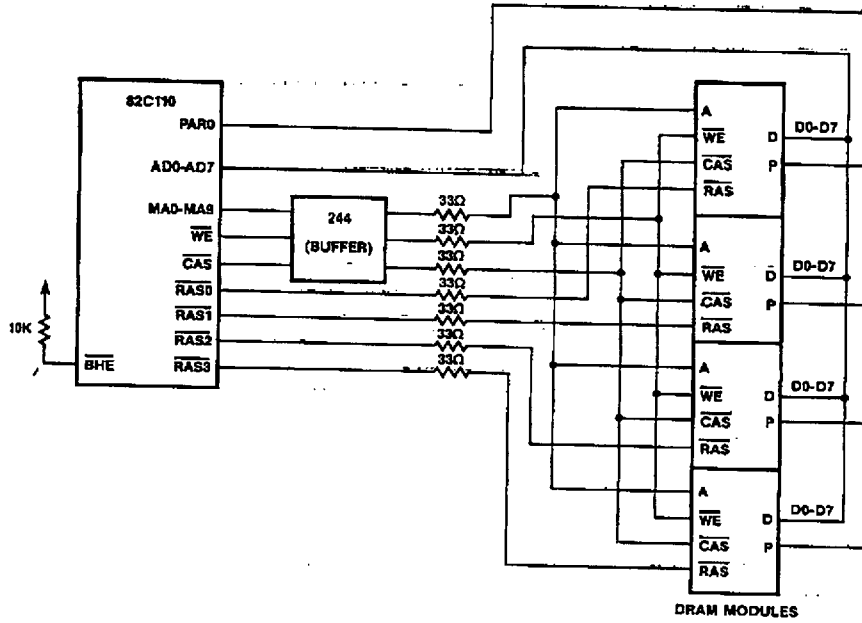

8-Bit DRAM Interface

**I/O Channel Interface**

The I/O Channel Interface has been enhanced by adding variable I/O wait state and command delays to account for slow peripherals and add-on cards. AD0 to AD19 are decoded to provide various internal device chip selects while AD10 to AD15 will be used for EMS page register address. For all internal I/O accesses  $\overline{DBEN}$  and  $\overline{DBIN}$  are low, thus the system bus data buffer is enabled, and the direction is outward to the I/O channel. For external accesses  $\overline{DBIN}$  is low for I/O writes, and high for I/O reads. The addresses (A1-A19) are latched by the transparent latches (74XX373 or equivalent), controlled by the ALE signal. An internally latched A0 signal is used in conjunction with the above. It should be buffered, but not latched in the transparent latches. The 82C110 toggles this bit for bus conversion cycles.

During bus conversion cycles a second set of commands are generated by the 82C110. First, the 82C110 toggles A0 incrementing the address. A second ALE is not generated.  $\overline{IOR}$ ,  $\overline{IOW}$ ,  $\overline{MEMR}$ ,  $\overline{MEMW}$ , AEN, DEN,  $\overline{DBEN}$ , and  $\overline{DBIN}$  will be generated accordingly creating the second cycle.

**Configuration Registers**

**INTERNAL CONFIGURATION/CONTROL REGISTERS**

Selection of the various options in the 82C110 is done through the configuration registers. There are six internal registers used to define the 82C110 configuration. These are accessed through a pair of IO ports (22H, and 23H). The definitions and index addresses of these are given below.

Accessing the Configuration Registers is a two step process:

- Step 1: Write the index of the configuration register to IO port 22H.
- Step 2: Followed by a read/write to IO port 23H.

To minimize accidental writes to these configuration registers, any access to location 23H must be preceded by a write to location 22H.

The configuration setup should be the first task performed after power is turned on, because it defines how the 82C110 interfaces to the rest of the system. For example, it selects the memory size, bus size and timing options of the commands. The configuration values can be stored in external battery-backed-up SRAM such as in the 82C606 CHIPSPak.

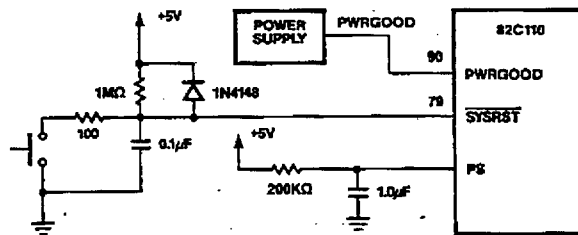

**Internal Configuration Registers Definition**  
**Index 40H: R/W - Clock/Mode Size.**

- bit 7: CLKSEL - Clock Select  
 0 = Slow Clock (4.77MHZ). (Default)  
 1 = Fast Clock (Max=10MHZ)

---

- bit 6: DC - Processor Clock duty cycle  
 0 = 33% duty cycle (8088/86). (Default)  
 1 = 50% duty cycle (V20/V30)

---

- bits 5-3: Reserved.

---

- bit 2: 2C - Two Clocks. Two clocks are present.  
 0 - One clock. 4.77MHz only. (Default)  
 1 - Two clocks. A second clock is at the POSC input.

This bit must be set before the clock source can be switched to run at a higher speed.

- bit 1: DS - DMA Clock Select  
 0 - Use system clock for DMA.  
 1 - Use system clock divided by 2 for DMA. (Default)

---

- bit 0: 16 - 16 bit memory/IO  
 Enables the bus conversion logic. It implies that an 8086 (or V30) processor with 16 bit bus is installed.  
 0 - 8 bit mode.  
 1 - 16 bit mode. (Default)

If the 82C110 is used with an 88/V20 then the BIOS must reset this bit immediately.

**Index 41H:R/W - System Configuration**

- bit 7: 0 - Reserved.

---

- bit 6: SR - Software Reset.  
 0 - Disable Software Reset Function. Default.  
 1 - Enable Software Reset Function.

- bit 5: Reserved.

---

- bit 4: EE - Enable EMS  
 0 - Enable EMS (Default)  
 1 - Disable EMS

---

- bit 3: CD - Command Delay  
 0 - Normal command timing. Default. Commands are asserted during T2.  
 1 - Delay command by 1 cycle. Commands are asserted during T3 instead of T2 to allow additional time for adapters to decode their address. The command is actually shortened by 1 cycle. An additional wait state should be specified to maintain the normal command width.

---

- bit 2: SM - System Memory Timing  
 0 - Normal wait states. System memory timing as controlled by other configuration register bits. (Default)  
 1 - Reduced wait states. The number of wait states is forced to 0 for system memory cycles. System memory is defined as memory in the 0-640K range and EMS address space that is controlled by the 82C110. When the command delay bit is set and an additional wait state has been specified to maintain command width, this bit should also be set to keep system memory timing the same.

---

- bit 1: Reserved.

---

- bit 0: EP - Enable Parity  
 0 - Enable parity check logic. (Default)  
 1 - Disable parity check logic.

**Index 42H:R/W - Configuration Valid**

bits 7-1: Reserved.

bit 0: VC - Valid Configuration

0 - Invalid configuration. When the 82C110 is powered up for the first time, this bit is 0, indicating that the configuration data in the configuration registers is invalid and should be set accordingly.

1 - Valid Configuration. This bit is set to a 1 by the configuration routine after it has successfully set the configuration registers. This bit will remain a 1 as long as power remains connected to the 82C110.

**Index 43H:R/W - DIP Switch Emulation**

Used to emulate the configuration DIP switches in an XT system. Default is 30H (1 floppy, monochrome display, 256KB, no 8087). This register is provided for software compatibility only and does not actually control any devices. The exception is bit 1, that tells the 82C110 whether or not a co-processor is present. The state of this bit tells the 82C110 which RQ/GT line to use. The BIOS should scan the devices present at power-up and set this register accordingly.

bits 7:6: Number of diskette drives installed

00 - 1 Floppy disk installed  
 01 - 2 Floppy disks installed  
 10 - 3 Floppy disks installed  
 11 - 4 Floppy Disks installed

bits 5:4: Display type

00 - EGA  
 01 - CGA 40 x 25  
 10 - CGA 80 x 25  
 11 - Monochrome 80 x 25

bits 3:2: RAM size on system board

00 - 256KB  
 01 - 512KB  
 10 - 576KB  
 11 - 640KB

bit 1: 8087 Numeric coprocessor installed

0 - Not installed  
 1 - Installed

bit 0: Loop on POST (for manufacturing test)

0 - Do not loop on POST  
 1 - Loop on POST

**Index 44H: R/W - Substitute NMI Vector Register, Byte 0**

**Index 45H: R/W - Substitute NMI Vector Register, Byte 1**

**Index 46H: R/W - Substitute NMI Vector Register, Byte 2**

**Index 47H: R/W - Substitute NMI Vector Register, Byte 3**

These four registers store the NMI vector that is substituted whenever an NMI is performed. This prevents modification of the NMI vector except under control of the BIOS.

**Index 48H: R/W - Refresh Timer Counter**

The 82C110 provides a programable refresh counter which allows usage of slow refresh DRAMs. Each value is a multiple of 838 ns (14,31818 Mhz divided by 12). A value of 00H is invalid, because the counter will never start. Therefore the minimum allowable value is 01H for 838 ns, and the maximum value is FFH for 214  $\mu$ s.

**Index 49H: R/W - Wait State Select, Refresh Enable, and Keyboard Type**

There are separate wait settings for I/O, memory, and DMA. The minimum number of wait states for I/O and DMA cycles is one, and the minimum for memory accesses is zero. The maximum for I/O and DMA is four, and three for memory. The refresh counter can be disabled by clearing bit 1. Bit 0 selects the type of keyboard to be used. When a PS/2 Model 25/30 keyboard is selected the

KBDATA output will be disabled, the KBCLK pin will become the IRQ1 input and port 60H will not be enabled allowing it to exist externally.

- bit 7-6: MWS - Memory Wait State
  - 00 - 0 Wait States. (Default)
  - 01 - 1 Wait State.
  - 10 - 2 Wait States.
  - 11 - 3 Wait States.

---

- bit 5-4: IOWS - I/O Wait State
  - 00 - 1 Wait State. (Default)
  - 01 - 2 Wait States.
  - 10 - 3 Wait States.
  - 11 - 4 Wait States.

---

- bit 3-2: DMAWS - DMA Wait State
  - 00 - 1 Wait State. (Default)
  - 01 - 2 Wait States.
  - 10 - 3 Wait States.
  - 11 - 4 Wait States.

---

- bit 1: REFEN - Refresh Enable
  - 0 - Disable Refresh Counter. (Default)
  - 1 - Enable Refresh Counter.

---

- bit 0: PS2KB - PS/2 Type Keyboard.
  - 0 - XT compatible keyboard type. Default.
  - 1 - PS/2 type keyboard.

**Index 4AH: Reserved**

**Index 4BH: R/W - Memory Configuration**

- bit 7: 0 - Reserved.

---

- bit 6: SN - Substitute NMI Vector.
  - The CPU attempts to read from locations 00008:0000BH when an NMI interrupt acknowledge sequence is performed. If this bit enabled, then the 82C110 substitutes the NMI vector stored in CREG<44:47H> for the vector stored in memory.
  - 0 - Disabled. Default.
  - 1 - Enabled.

---

- bit 5-4: 0 - Reserved.

---

- bits 3:0: Memory Configuration.
  - Four bits are used to specify one of 16 predefined 8 or 16 bit configurations from 128KB to 2.5MB.

8 bit wide Configurations

Value	B0	B1	B2	B3	Sys	EM	Total
0	—	—	—	—	—	—	0K
1	64K	64K	—	—	128K	—	128K
2	64K	—	256K	—	320K	—	320K
3	64K	64K	256K	—	384K	—	384K
4	64K	64K	256K	256K	640K	—	640K
5	256K	—	—	—	256K	—	256K
6	256K	256K	—	—	512K	—	512K
7	256K	256K	256K	—	640K	128K	768K
8	256K	256K	256K	256K	640K	384K	1024K
9	256K	256K	256K	256K	512K	512K	1024K
A	—	—	1M	—	640K	384K	1024K
B	—	—	I N V A L I D		—	—	—
C	256K	256K	1M	—	640K	896K	1536K
D	—	—	1M	1M	640K	1408K	2048K
E	—	—	I N V A L I D		—	—	—
F	256K	256K	1M	1M	640K	1920K	2560K

16 bit wide Configurations

Value	B0	B1	B2	B3	Sys	EM	Total
0	—	—	—	—	—	—	0K
1	64K	64K	—	—	128K	—	128K
2	—	—	I N V A L I D		—	—	—
3	—	—	I N V A L I D		—	—	—
4	64K	64K	256K	256K	640K	—	640K
5	—	—	I N V A L I D		—	—	—
6	256K	256K	—	—	512K	—	512K
7	—	—	I N V A L I D		—	—	—
8	256K	256K	256K	256K	640K	384K	1024K
9	256K	256K	256K	256K	512K	512K	1024K
A	—	—	I N V A L I D		—	—	—
B	—	—	I N V A L I D		—	—	—
C	—	—	I N V A L I D		—	—	—
D	—	—	1M	1M	640K	1408K	2048K
E	—	—	I N V A L I D		—	—	—
F	256K	256K	1M	1M	640K	1920K	2560K

**Memory Configuration Options**

The first column is the value that should be set in the memory configuration field. The next four columns specify the type of device used for the respective bank. The next two columns summarize the amount of memory available for system or EMS. The last column

indicates the total amount of planar memory. Note: Only configurations with pairs of banks with identical devices are valid for 16 bit systems. This is because in 16 bit mode, B0 and B1 become a single 16 bit bank with the low order byte in B0 and the high order byte in B1. The same thing happens with B2 and B3.

### Index 4CH: R/W - EMS Configuration Register

bit 7:4: Expanded Memory IO port address.

These bits define the single IO address port through which the EMS page registers are accessed. Bits 15:14 of the IO address are used to select which of the four page registers is being accessed.

Caution: Values that are (R)eserved should not be used, they may cause conflicts with other devices.

Value	IO Address	Value	IO Address
0H	208H	8H	288H (R)
1H	218H	9H	298H (R)
2H	228H (R)	AH	2A8H
3H	238H (R)	BH	2B8H
4H	248H (R)	CH	2C8H (R)
5H	258H	DH	2D8H (R)
6H	268H	EH	2E8H
7H	278H (R)	FH	2F8H (R)

bits 3:0: Expanded Memory Base Address

This Base Address specifies the starting address of the first 16K byte page that expanded memory is accessible at. Up to 3 more pages can be made accessible starting at successive 16K blocks.

Value	Base Address	Value	Base Address
0H	C0000H	5H	D4000H
1H	C4000H	6H	D8000H
2H	C8000H	7H	DC000H
3H	CC000H	8H	E0000H
4H	D0000H	9-FH	Reserved

4DH: Reserved

4EH: Reserved

4FH: Reserved

### ADDITIONAL I/O REGISTERS

There are several extra registers needed for the enhanced features of the 82C110. These are I/O registers located in Planar I/O Map (below 100H), and are extensions of the standard PC architecture.

72H - Reserved

7EH - R/W - NMI Status, Indicates the source of NMI.

When an NMI is generated, software needs to know what the source is in order to process the correct NMI service routine. The source of the NMI is latched into this register. The NMI generated to the processor is an ORed condition of any of the NMI Status register bits.

bit 7: Reserved.

bit 6: IOCHCK, I/O Channel Check (pin 72) status.

When this bit is set to 1, the IOCHCK input (pin 72) is LOW indicating a parity or other error indication on memory or devices on the I/O channel.

bit 5: PERR, System memory parity error.

This bit is set to 1 when there is a parity error in the planar system memory. During a memory read cycle, PAR1 (pin 92), and PAR0 (pin 93) bits are compared with the calculated parity. If they do not agree, an NMI will be generated (if NMI's are enabled), and this bit will be set.

bit 4:0: Reserved.

7FH - R/W - Reset.

bit 7:4: Reserved

bit 3: Software Controlled Reset

0 - Inactive

1 - Asserts System Reset

When this bit is set, the RESET output (pin 81) will be active for a minimum of four clock pulses. Bit 6 of configuration register 41H must be set high for this function to work.

bit 2:0: Reserved.

**AxH - W - NMI Control (x = 0 through FH)**

bit 7 NMI Enable  
 0 - Disable all NMIs.  
 1 - Enable all NMIs, Default.  
 Resetting this bit to 0 masks off the NMI signal to the CPU. But an NMI can be recognized through software, because the source of the NMI is stored in the above NMI status register.

bit 6:0 Reserved.

**Enhanced Operating Modes**

**EXPANDED MEMORY SYSTEM**

The Lotus/Intel/Microsoft Expanded Memory Specification is a functional definition of bank switched memory expansion modules and driver programs. EMS allows up to 8MB of expansion memory viewed as 16KB logical pages. One to four pages are available to the application software, and they can be contiguous to 64KB.

Expanded memory should not be confused with Extended memory. Extended memory is memory at physical addresses above 1MB while expanded memory is bank-switched and addressed below 1MB. Extended memory applies to systems with CPUs that can address physical memory larger than 1 MB, such as the 80286 or 80386.

The LIM EMS allows application software to access to memory greater than the normal 640K limit in PC and XT architecture machines. A page mapping scheme is managed by an EMS software driver. At any time up to 4 pages of successive 16KB are made accessible through various windows located from C0000H to EFFFFH. There are two registers in the Internal Configuration Register, EMIO (Expanded Memory IO port address) and EMBA (Expanded Memory Base Address). EMBA specifies the starting memory address for the first 16KB page, and EMIO defines the I/O port address for the page register. Bits 15:14 of this address are used to select which of

the four page registers are being accessed. The I/O address of the page register is set in ICR 4CH.

Currently there are several varieties of Expanded Memory Specifications. The 82C110 supports the LIM EMS version 4.0.

**SOFTWARE CONSIDERATIONS**

The EMS installable driver, the EMM (Expanded Memory Manager), provides the hardware independent interface to the application software. The application communicates directly with the EMM through INT 67H without MSDOS intervention.

For more information please refer to:

The Lotus/Intel/Microsoft Expanded Memory Specification, Version 4.0. It is available by calling Intel at 800-538-3373.

**EMS Configuration definition:**

bit 7:4 EMIO	
0H	x208H
1H	x218H
2H	x228H (R)
3H	x238H (R)
4H	x248H (R)
5H	x258H
6H	x268H
7H	x278H (R)
8H	x288H (R)
9H	x298H (R)
AH	x2A8H
BH	x2B8H
CH	x2C8H (R)
DH	x2D8H (R)
EH	x2E8H
FH	x2F8H (R)

Where x = 0, 4, 8 or CH to select one of the four EMS page registers. This upper nibble must be sent correctly by the I/O instruction, but is not used in the actual decode of the I/O port. Note that those ports marked with an (R) should not be used because of potential address conflicts.



3:0	EMBA	
	0H	C0000H
	1H	C4000H
	2H	C8000H
	3H	CC000H
	4H	D0000H
	5H	D4000H
	6H	D8000H
	7H	DC000H
	8H	E0000H
	9H:FH	Reserved

**To access EMS memory:**

- Select starting memory address through the ICR, i.e.:
  - Write Index 4CH to port 22H
  - Select EMBA to be used (low nibble)
  - Select EMIO to be used (high nibble)
  - Write EMBA and EMIO (as a byte) to port 23H.
- Write the four EMS page registers. The address is determined by EMIO plus the highest 2 bits (bit 15:14) of the I/O port address to select which of the four registers being accessed. Each byte in the page register selects a 16KB block of EMS memory.
- The EMS memory is then accessed through the window selected above (EMBA). The size of the window is 64KB. The four 16KB pages are located within the window according to the following table:

Page Register	Address
0	Window base
1	Window base + 4000H
2	Window base + 8000H
3	Window base + C000H

The bit assignment of the page registers is as per the LIM specification. The MSB (Most Significant Bit) is the enable bit for accessing the expanded memory. Setting that bit allows software to access expanded memory. The rest of the bits are used for selecting any of the available 16KB pages. The maximum value of the page register would depend on how much memory is available for EMS.

For example in 1 MB system, upper 384KB can be addressed as expanded memory. In this case the valid page register values in order to access the expanded memory would be 80H through 97H, as there are 18H pages available for expanded memory.

**CLOCK GENERATION AND SWITCHING**

The 82C110 supports two clock speeds for the CPU and system bus: 4.77 MHz, and 1/3 of the POSC frequency. It also supports two duty cycles: 33% and 50% to support 808X and NEC's V20/V30 CPUs. Clock switching is synchronized, based on an edge detector that holds the clock low while switching from one clock to the other eliminating any short clock pulses.

**On power up the defaults are:**

- 4.77 MHz system clock (210 ns clock cycle)
- 33% duty cycle for CPU clock

To switch clock speed or duty cycle the following sequence should be followed:

- Set the desired number of wait states for memory, I/O and DMA, and command delay to guarantee setup and hold time for the new bus speed. Write these values to the appropriate ICR (please refer to Internal Configuration Register section).
- Switch the clock by writing to ICR 40H.

**I/O CHANNEL TIMING CONTROL**

I/O channel timing can be manipulated by setting the appropriate number of wait states, and setting command delay ON/OFF. Adding wait states makes the cycles longer and provides more data setup time. The wait state logic adds Tw's between T3 and the last cycle (T4). On the other hand, delaying the command gives more time for address setup. If command delay is enabled, the commands (IOR, IOW, MEMR, and MEMW) are delayed by one clock

cycle and become active at T3 instead of T2. Therefore the time between address valid to command active is 1 cycle longer than normal cycles, allowing more time for external devices to decode the address. Command delay is applicable for both I/O and memory cycles. By setting ICR 41H bit 3 to 1, commands are delayed by 1 cycle. Default is normal, no delays.

**DATA CONVERSION**

Since the 82C110 can operate with 16 bit processors (8086 or V30), a 16 bit multiplexed data bus must be supported. The 82C110 will control and perform data conversion between the 16 bit processor data and the 8 bit IO channel.

The effect of bus conversions are:

1. A 16 bit processor read is converted to two 8 bit IO channel reads.
2. A 16 bit processor write is converted to two 8 bit IO channel writes.

The 82C110 recognizes the need for bus conversion cycles when the following three conditions are met:

1.  $\overline{BHE}$  is LOW.
2. A0 is LOW.
3. External cycles. 82C110 determines internal or external cycles by decoding the address and status information. The cycles requiring bus conversion are: Any memory access to a location not in the planar RAM or ROM and I/O cycles to locations not internal to the 82C110.

The cross over is done internally. The 82C110 provides the signals to control the enables and directions of the external buffers. Refer to the conversion cycle timing on the next pages.

**16 bit CPU write to 8 bit device sequence:**

1. The 82C110 issues NOT-READY (READY is low) to the CPU when it recognizes any bus conversion cycles.

2. CPU transfers 16 bit data to the 82C110.
3. 82C110 allows the low byte to go through by setting PBEN LOW and PBIN HIGH.
4. The low byte is transferred directly to the I/O channel.  $\overline{DBEN}$  is set LOW to enable the I/O channel data buffer.
5. After low byte transfer, 82C110 toggles A0 to HIGH, sending the odd address to the I/O channel.
6. The high byte is transferred to the low byte internal to the 82C110. The write command is generated and a wait state is added if programmed to do so. The second (high) byte is transferred.
7. READY is set to HIGH, indicating the end of transfer.

**16 bit CPU read from 8 bit device sequence:**

1. 82C110 issues NOT-READY to CPU.
2. A0 is set LOW.
3. The 82C110 generates a read command and reads the low byte external data into the on board low byte.
4. A0 is toggled HIGH.
5. A second read command is generated.
6. The 82C110 transfers the low byte into high byte internally.
7. The 82C110 changes READY to HIGH indicating the end of transfer.

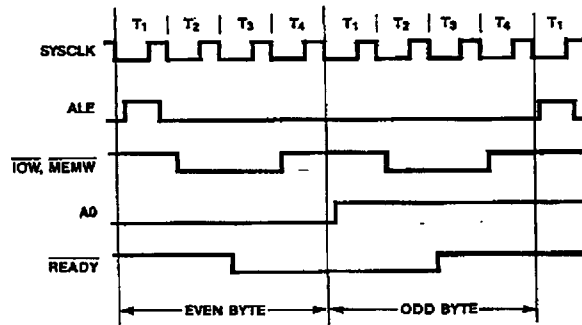

**Write Conversion Cycle  
(0 Memory Wait States)**

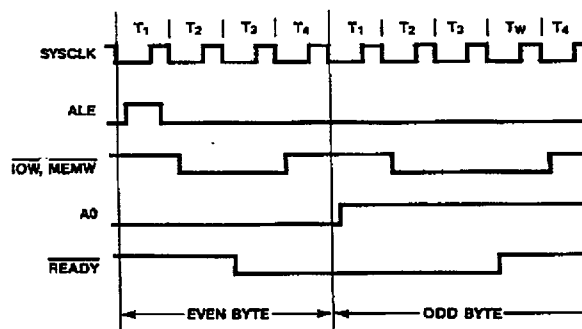

**Read Conversion Cycle  
(0 Memory Wait States)**

**Address Mapping**

**IO MAP**

Address	R/W	Description
<b>DMA Controller</b>		
000H	R/W	DMA Channel 0 current address
001H	R/W	DMA Channel 0 current word count
002H	R/W	DMA Channel 1 current address
003H	R/W	DMA Channel 1 current word count
004H	R/W	DMA Channel 2 current address
005H	R/W	DMA Channel 2 current word count
006H	R/W	DMA Channel 3 current address
007H	R/W	DMA Channel 3 current word count
008H	W	DMA Command Register
	R	DMA Status Register
009H	W	DMA Request Register
00AH	W	DMA Single Bit Mask Register
00BH	W	DMA Mode Register
00CH	W	DMA Clear Byte Pointer
00DH	W	DMA Master Clear
00EH	W	Clear Mask Register
00FH	W	DMA Write All Mask Register Bit

## Interrupt Controller

020H	W	INTC ICW1
	W	INTC OCW2
	W	INTC OCW3
	R	INTC Interrupt Request Register (IRR)
	R	INTC In-Service Register (ISR)
021H	R	INTC Polling Data Byte
	W	INTC ICW2
	W	INTC ICW4
	W	INTC OCW5
	R	INTC Interrupt Mask Register (IMR)

## Internal Configuration Registers

022H	R/W	Internal Configuration Index Register
023H	R/W	Internal Configuration Data Register

Index	Description
40H	R/W Clock/Mode
41H	R/W System Configuration
42H	R/W Configuration Valid
43H	R/W PC/XT DIP Switch Emulation
44H	R/W NMI Vector Byte 0 (LSB)
45H	R/W NMI Vector Byte 1
46H	R/W NMI Vector Byte 2
47H	R/W NMI Vector Byte 3 (MSB)
48H	R/W Refresh Counter
49H	R/W Wait, Refresh, Keyboard
4AH	— Reserved
4BH	R/W Memory Configuration
4CH	R/W EMS Control
4D:4FH	— Reserved

## Timer/Counter Registers

040H	R/W	Timer 0 Count Load/Read
041H	R/W	Timer 1 Count Load/Read
042H	R/W	Timer 2 Count Load/Read
043H	R/W	Timer Control Word

## PPI Registers

060H	R/W	Parallel Port A
061H	R/W	Parallel Port B
062H	R/W	Parallel Port C

## Additional I/O Registers

072H	R/W	NMI Control
07EH	R/W	NMI Status
07FH	R/W	RESET
0AxH	R/W	NMI Mask
0CxH	R/W	Reserved
0ExH	R/W	Reserved

Note: x = 0-FH

**DMA Page Registers**

081H	W	DMA Channel 2 Page Register
082H	W	DMA Channel 3 Page Register
083H	W	DMA Channel 1 Page Register

**EMS Page Registers**

x208H	R/W	EMS Page Register
x218H	R/W	EMS Page Register
x228H (R)	R/W	EMS Page Register
x238H (R)	R/W	EMS Page Register
x248H (R)	R/W	EMS Page Register
x258H	R/W	EMS Page Register
x268H	R/W	EMS Page Register
x278H (R)	R/W	EMS Page Register
x288H (R)	R/W	EMS Page Register
x298H (R)	R/W	EMS Page Register
x2A8H	R/W	EMS Page Register
x2B8H	R/W	EMS Page Register
x2C8H (R)	R/W	EMS Page Register
x2D8H (R)	R/W	EMS Page Register
x2E8H	R/W	EMS Page Register
x2F8H (R)	R/W	EMS Page Register

**Notes:**

1. x = 0H, 4H, 8H, or CH
2. (R) are reserved and should not be used to avoid conflicts with other devices.
3. Only one of these registers will exist at one time. The actual address used is programmable.

**Memory Map**

00000-9FFFFH	R/W	RAM
C0000-EFFFFH	R/W	EMS
F0000-FFFFFH	R	ROM

**82C110 Absolute Maximum Ratings**

Parameter	Symbol	Min.	Max.	Units
Supply Voltage	V <sub>CC</sub>	3.0	5.5	V
Input Voltage	V <sub>I</sub>	-0.5	5.5	V
Output Voltage	V <sub>O</sub>	-0.5	5.5	V
Operating Temperature	T <sub>OP</sub>	-25	85	°C
Storage Temperature	T <sub>STG</sub>	-40	125	°C

**Note:** Permanent device damage may occur if Absolute Maximum Ratings are exceeded. Functional operation should be restricted to the conditions described under Operating Conditions.

**82C110 Operating Conditions**

Parameter	Symbol	Min.	Max.	Units
Supply Voltage	V <sub>CC</sub>	4.75	5.25	V
Ambient Temperature	T <sub>A</sub>	0	70	°C

**Capacitance** (T<sub>A</sub> = 25°C, V<sub>CC</sub> = GND = 0V)

Sym	Parameter	Min.	Max.	Units	Test Conditions
C <sub>IN</sub>	Input Capacitance	—	10	pF	SYSCLK = 0.5MHz
C <sub>OUT</sub>	Output Capacitance	—	20	pF	Returned to V <sub>SS</sub>
C <sub>I/O</sub>	I/O Capacitance	—	20	pF	Unmeasured pins

**DC Characteristics** (T<sub>A</sub> = 25°C, V<sub>CC</sub> = 5V ±10%)

Sym	Parameter	Min.	Max.	Units	Test Conditions
V <sub>IL</sub>	Input Low Voltage	-0.5	0.8	V	
V <sub>IH</sub>	Input High Voltage	2.0	V <sub>CC</sub> +0.5	V	
V <sub>OL</sub>	Output Low Voltage	—	0.4	V	I <sub>OL</sub> = 4.0mA (1)
V <sub>OH</sub>	Output High Voltage	2.4	—	V	I <sub>OH</sub> = -4.0mA (2)
V <sub>CL</sub>	Clock Output Low	—	0.4	V	I <sub>OL</sub> = 4.0mA
V <sub>CH</sub>	Clock Output High	3.9	—	V	I <sub>OH</sub> = -4.0mA
I <sub>IL</sub>	Input Leakage Current	-10	20	μA	V <sub>I</sub> = V <sub>CC</sub> to 0V
I <sub>OL</sub>	Output Leakage Current	-10	20	μA	V <sub>O</sub> = V <sub>CC</sub> to 0.45V
I <sub>CC</sub>	V <sub>CC</sub> Supply Current	—	30	mA	POSC = 30MHz
I <sub>STBY</sub>	Standby Current	—	-100	μA	POSC = DC

**Notes:**

- I<sub>OL</sub> = 12mA for RAS<sub>n</sub>, AD0-AD7, I<sub>OL</sub> = 15mA for KBCLK, KBDATA.
- I<sub>OH</sub> = -24mA for RAS<sub>n</sub>, AD0-AD7.

**82C110 AC Characteristics** (T<sub>A</sub> = 0-70°C, V<sub>CC</sub> = 5V ±10%)

Symbol	Parameter	Min	Max	Units
<b>Reset Signals</b>				
t1	V <sub>CC</sub> Valid to PWRGOOD Active	1		ms
t2	PWRGOOD to SYSRST Inactive	200		ns
t3	RESET Active from PWRGOOD	0		ns
t4	RESET Inactive from CLK	10	Tc/3	ns

**82C110 AC Characteristics (Continued)**

Symbol	Parameter	Min	Max	Units
<b>Clock Signals</b>				
t10	CX1, POSC Cycle Time	34		ns
t11	CX1, POSC Rise Time		10	ns
t12	CX1, POSC Fall Time		10	ns
t13	CX1, POSC High Time	10		ns
t14	CX1, POSC Low Time	10		ns
t15	CX1, POSC to OSC Delay	8	14	ns
t17	OSC Cycle Time	34		ns
t18	OSC Rise Time		8	ns
t19	OSC Fall Time		8	ns
t21	OSC High Time			ns
t22	OSC Low Time			ns
t23	CLK Rise Time		8	ns
t24	CLK Fall Time		8	ns
t25	CLK High Time (33% Duty Cycle)			ns
t26	CLK Low Time (33% Duty Cycle)			ns
t27	CLK High Time (50% Duty Cycle)			ns
t28	CLK High Time (50% Duty Cycle)			ns
t29	CLK Cycle Period (T <sub>c</sub> )	100		ns
POSC	POSC Frequency	DC	30	MHz
OSCI	OSCI Frequency	DC	30	MHz
<b>Arbitration and Ready Signals</b>				
t30	$\overline{RQ}$ Active from CLK	5	45	ns
t31	$\overline{RQ}$ Inactive from CLK	5	35	ns
t32	$\overline{GT}$ Setup from CLK	5	35	ns
t33	$\overline{GT}$ Setup from CLK	5	45	ns
t34	$\overline{REL}$ Active from CLK	5	45	ns
t35	$\overline{REL}$ Inactive from CLK	5	30	ns
t36	$\overline{TOCHRDY}$ Setup to CLK	5	30	ns
t37	$\overline{TOCHRDY}$ Hold to CLK	5	30	ns
t38	READY Inactive from CLK	0	15	ns
t39	READY Active from CLK	0	15	ns
<b>CPU Interface Signals</b>				
t40	ALE Active from CLK	5	40	ns



**82C110 AC Characteristics (Continued)**

Symbol	Parameter	Min	Max	Units
t41	ALE Inactive from CLK (rising edge T1)	8	24	ns
t42	PBEN Active from CLK	10	30	ns
t44	PBEN Inactive from CLK	$T_C/3$	$T_C/3+35$	ns
t45	PBIN Delay from CLK	5	30	ns
t46	PBIN Active from CLK	$T_C/3$	$T_C/3+20$	ns
t47	PBIN Inactive from CLK	$2T_C/3$	$2T_C/3+30$	ns
t48	DBEN Active from CLK (read)	$2T_C/3$	$2T_C/3+30$	ns
t49	DBEN Active from CLK (write)	0	30	ns
t50	DBEN Inactive from CLK (read/write)	$T_C/3$	$2T_C/3$	ns
t51	DBIN Active from CLK	0	60	ns
t52	DBIN Inactive from CLK	$T_C/3$	$T_C/3+30$	ns
t53	Command Active from CLK	10	35	ns
t54	Command Inactive from CLK	10	35	ns
t55	DEN Active from CLK (read)	$2T_C/3$	$2T_C/3+30$	ns
t56	DEN Active from CLK (write)	0	30	ns
t57	DEN Inactive from CLK (read)	10	30	ns
t58	DEN Active from CLK (write)	$2T_C/3$	$2T_C/3+30$	ns
t59	BHE Active from CLK	10	45	ns
t60	BHE Inactive from CLK	10	45	ns
t61	A0 Delay from CLK	20	55	ns
<b>DRAM Control Signals</b>				
t63	RAS Active from CLK	$T_C/3$	$T_C/3+25$	ns
t64	RAS, CAS, WE Inactive from CLK	$T_C/3$	$T_C/3+25$	ns
t65	CAS Active from CLK	0	20	ns
t66	WE Active from CLK	$2T_C/3$	$2T_C/3+25$	ns
t67	Row Address Delay From CLK	30	85	ns
t68	Column Address Delay From CLK	$2T_C/3$	$2T_C/3+25$	ns
t69	Address Float Delay From CLK	$T_C/3$	$T_C/3+30$	ns
<b>ROM Signals</b>				
t70	ROMCS Active from CLK	0	30	ns
t71	ROMCS Inactive from CLK	10	30	ns

**82C110 AC Characteristics (Continued)**

Symbol	Parameter	Min	Max	Units
<b>DMA Controller Signals</b>				
t80	DREQ Setup to CLK	0		ns
t81	DREQ Hold to CLK	0		ns
t82	AEN Active from CLK	$2T_{\text{CLK}}/3$	$2T_{\text{CLK}}/3 + 30$	ns
t83	AEN Inactive from CLK	$2T_{\text{CLK}}/3$	$2T_{\text{CLK}}/3 + 30$	ns
t84	DACK Active from CLK	0	100	ns
t85	DACK Inactive from CLK	0	100	ns
t86	Command Active from CLK	10	35	ns
t87	Command Inactive from CLK	10	35	ns
t89	AD0-AD15, A16-A19 Valid from CLK	0	60	ns
<b>Interrupt Controller Signals</b>				
t112	INTR Active from IRQ		300	ns
t113	INTR Inactive from CLK	0	45	ns
t116	INTR Vector Setup from CLK	30		ns
t117	INTR Vector Hold from CLK	10		ns
t118	IRQ, NMI Low Width	100		ns
t119	Command Recover Time	150		ns

**Notes:**

1. Measured between 1.0V to 3.5V for 8088/8086 CPU
2. Measured between 1.5V and 3.0V for V20/V30 CPU

82C110 Timing Diagrams

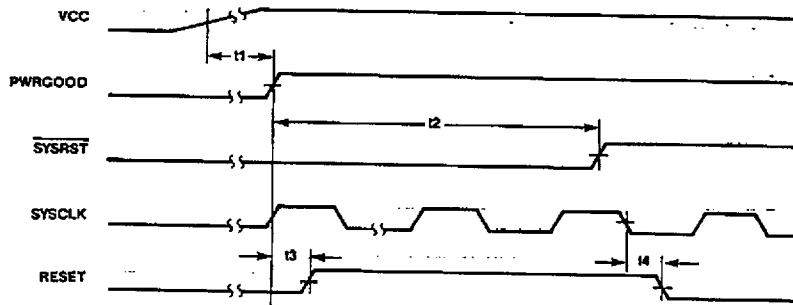

Reset Signals

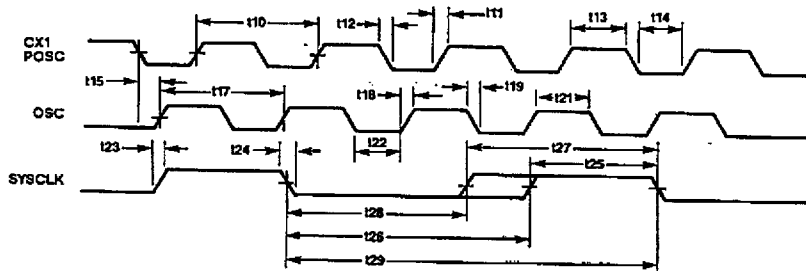

Clocks

82C110 Timing Diagrams (Continued)

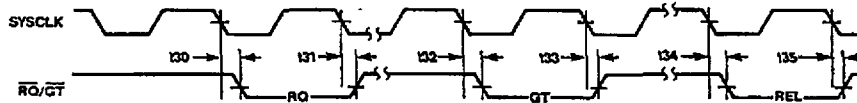

Request/Grant/Release

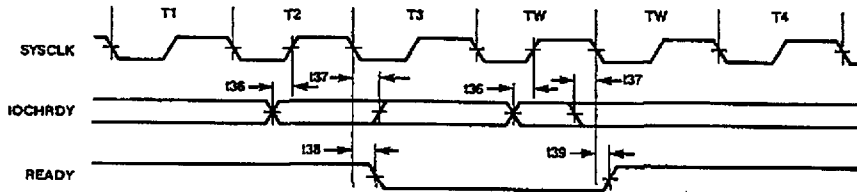

Ready Timing

82C110 Timing Diagrams (Continued)

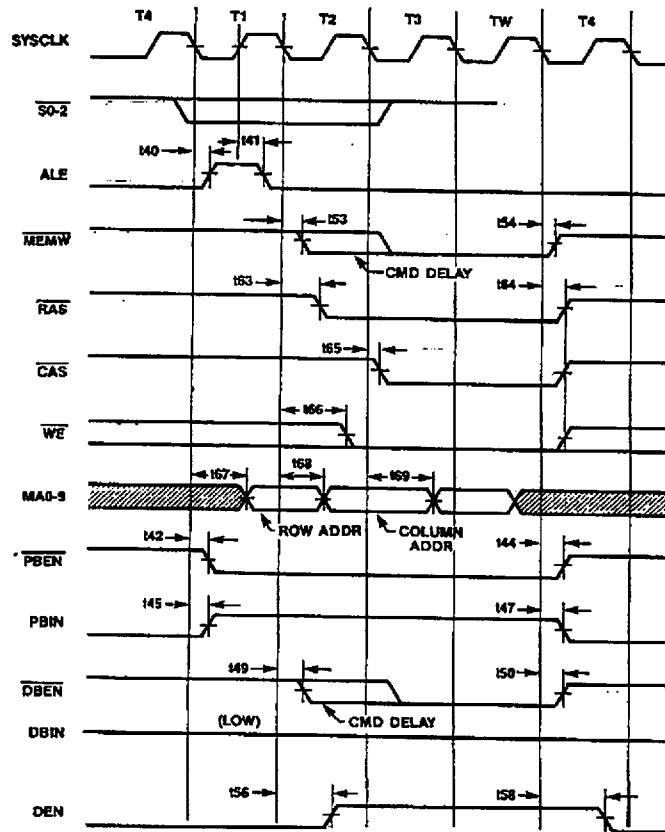

Memory Write

82C110 Timing Diagrams (Continued)

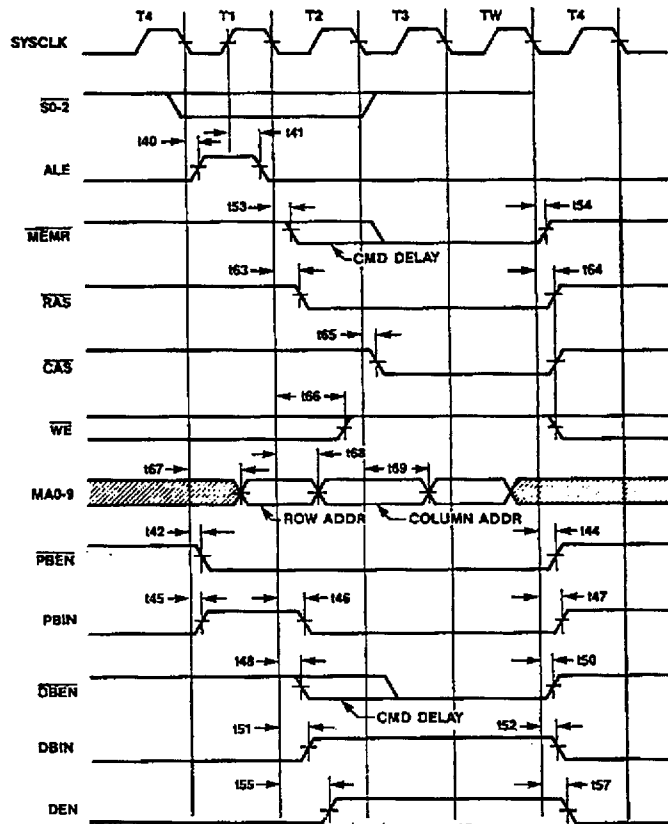

Memory Read

82C110 Timing Diagrams (Continued)

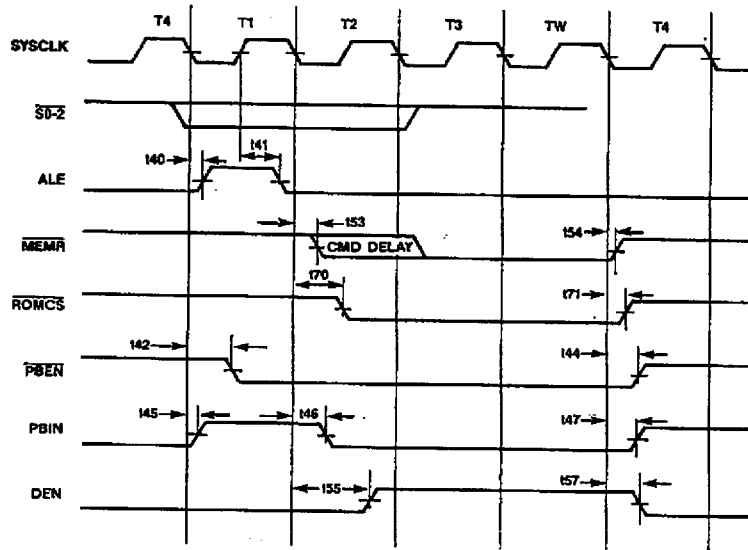

ROM BIOS Read

82C110 Timing Diagrams (Continued)

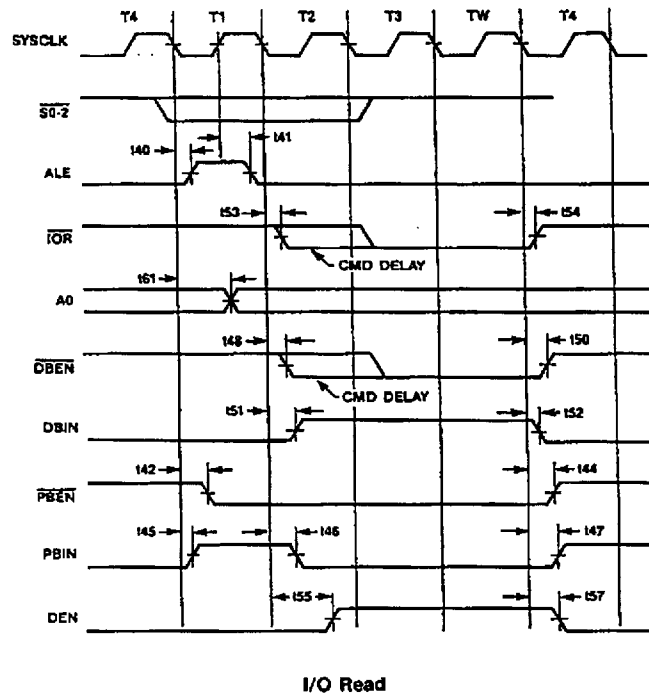

I/O Read



82C110 Timing Diagrams (Continued)

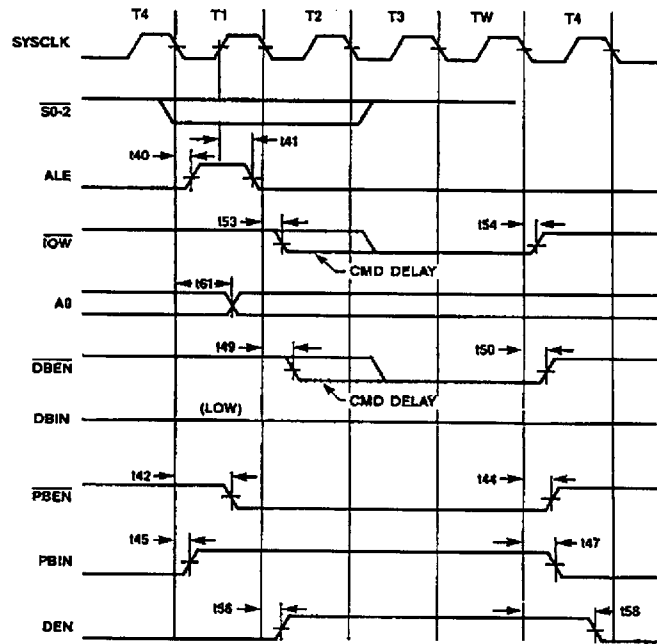

I/O Write

82C110 Timing Diagrams (Continued)

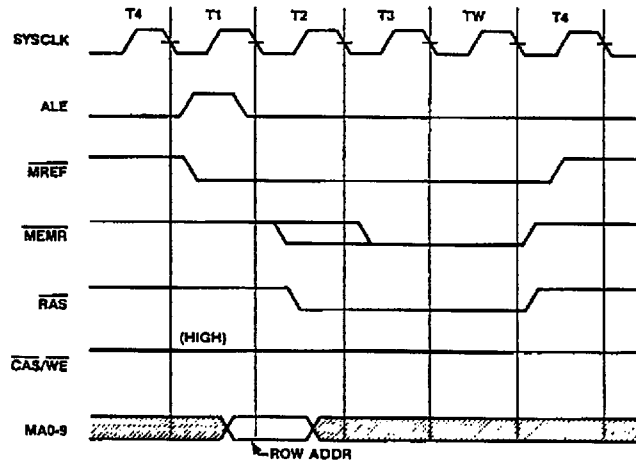

Memory Refresh Cycle

82C110 Timing Diagrams (Continued)

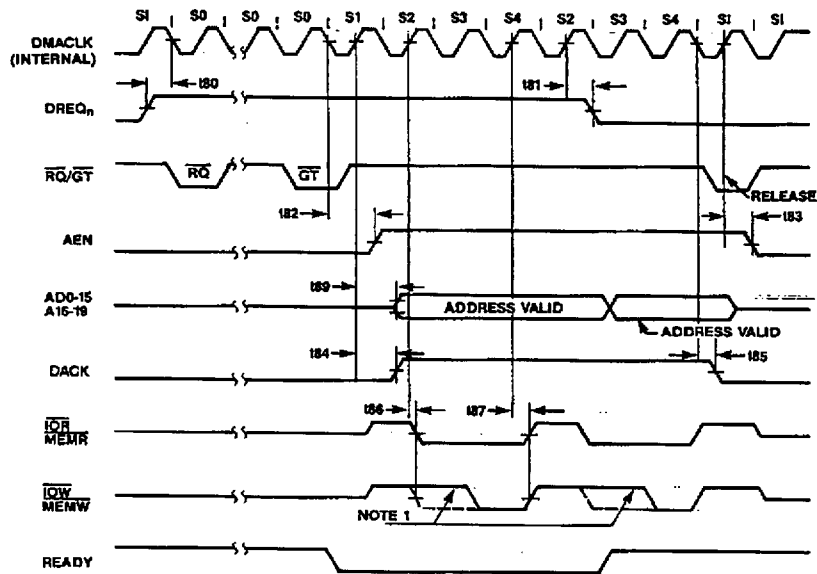

Note 1: Extended Write Mode

DMA Basic Timing

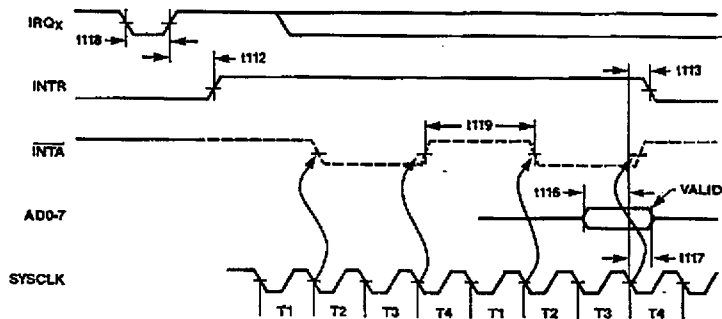

Note 1: INTA is internal to the 82C110.

INTA Sequence/NMI Vector Substitution

82C110 Timing Diagrams (Continued)

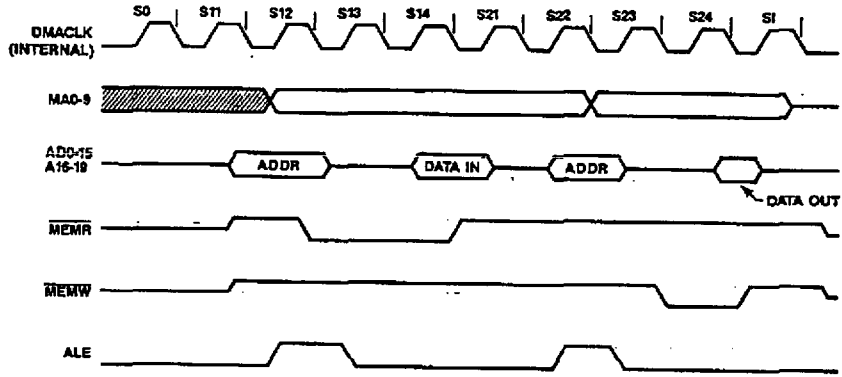

Memory to Memory DMA Transfer

**CHIPS**

PRELIMINARY

100-PIN PLASTIC FLAT PACKAGE (RECTANGULAR)

DIMENSIONS: mm (in)

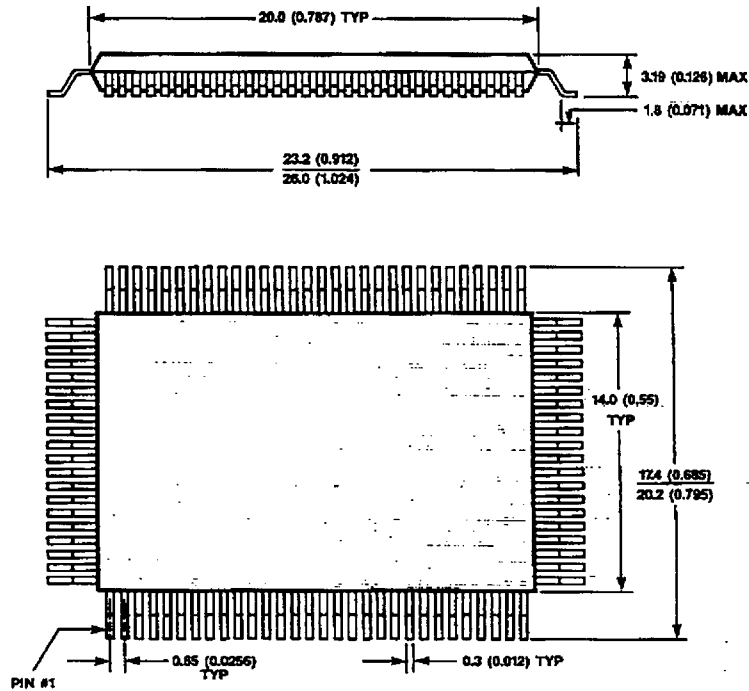

**Ordering Information**

Order Number	Package Type
F82C110	PFP-100

Notes:  
1. PFP = Plastic Flat Package