

ZLXp-L1 and ZLXp-L2 PCI Graphics Options

Owner's Guide

Order Number: EK-PVPCI-OG. D01

Fourth Printing, May, 1996

Digital Equipment Corporation makes no representations that the use of its products in the manner described in this publication will not infringe on existing or future patent rights, nor do the descriptions contained in this publication imply the granting of licenses to make, use, or sell equipment or software in accordance with the description.

© Digital Equipment Corporation 1996. All Rights Reserved.
Printed in U.S.A.

The following are trademarks of Digital Equipment Corporation: DEC, Digital, Digital Open3D, Digital UNIX, OpenVMS, VAX DOCUMENT, and the DIGITAL logo.

Microsoft is a registered trademark, and Windows NT is a trademark of Microsoft Corporation.

All other trademarks and registered trademarks are the property of their respective holders.

This document was prepared using VAX DOCUMENT Version 2.1.

FCC Notice:

FCC ID: A09-PSPVPCI

This device complies with Part 15 of the FCC Rules. Operation is subject to the following conditions:

1. This device may not cause harmful interference, and
2. This device must accept any interference received, including interference that may cause undesired operation.

This equipment has been tested and found to comply with the limits for a Class B digital device, pursuant to Part 15 of the FCC Rules. These limits are designed to provide reasonable protection against harmful interference in a residential installation. Any changes or modifications made to this equipment may void the user's authority to operate this equipment.

This equipment generates, uses, and can radiate radio frequency energy and, if not installed and used in accordance with the instruction manual, may cause harmful interference to radio communications. However, there is no guarantee that interference will not occur in a particular installation. If this equipment does cause harmful interference to radio or television reception, which can be determined by turning the equipment off and on, the user is encouraged to try to correct the interference by one or more of the following measures:

- Reorient or relocate the receiving antenna.
- Increase the separation between the equipment and receiver.
- Connect the equipment into an outlet on a circuit different from that to which the receiver is connected.
- Consult the dealer or an experienced radio/TV technician for help.

The video and stereo cable ports should be connected with only shielded data cables with an external ferrite bead over the cable. When either of these ports is connected with cables without such a ferrite bead, additional ferrite beads shall be clamped over these cables next to the cable connector.

**DOC
Compliance
Statement**

This digital apparatus does not exceed the class B limits for radio noise emissions from digital apparatus set out in the Radio Interference Regulations of the Canadian Department of Communications.

**MDC Avis De
Conformation**

Le present appareil numerique n'emet pas de bruits radioelectriques depassant les limites applicables aux appareils numeriques de Classe B prescrites dans le Reglement sur le brouillage radioelectriques edicte par le ministere des Communications du Canada.

EMI

This product complies with the following domestic and international standards:

- Domestic: Complies with FCC Part 15, Class B.
- International: Complies with CISPR22 (EN55022 (European Norm)) Class B.

VCCI:

この装置は、第一種情報装置（商工業地域において使用されるべき情報装置）で商工業地域での電波障害防止を目的とした情報処理装置等電波障害自主規制協議会（VCCI）基準に適合しております。

従って、住宅地域またはその隣接した地域で使用すると、ラジオ、テレビジョン受信機等に受信障害を与えることがあります。

取扱説明書に従って正しい取り扱いをして下さい。

Contents

Guide Overview	1
Purpose	1
Audience	1
Contents	1
Conventions	2
Reader's Comments	2
Description of the Modules	3
Purpose	3
ZLXp-L1 and ZLXp-L2 Module Information	3
Software	4
Warranty	4
Description	5
Setting the VGA Jumper	6
Monitor Values	7
Installing the ZLXp-L Display Driver Software	8
Software Overview	8
System Requirements	8
Installation Procedure	8
Texturing Speed vs Texturing Precision	10
Installing the Module	11
Procedure	11
Confirming Proper Installation	13
Reboot the System	13
Setting the Screen Resolution and Refresh Rate	14
Identifying the Display Driver Version	15
Troubleshooting	17
Handling Problems Worksheet	18
Stereo Viewing	19
Description	19
Stereo Cable	19
Stereo Monitor	19
Appendix A — Module Specifications	20
Physical Specifications	20

Environmental Specifications	20
Power Consumption	21
Appendix B — Cables	22
Cabling Information	22
Appendix C — FRUs—For Digital Service	23
Ordering FRUs	23

Index

Figures

1	ZLXp-L1 and ZLXp-L2 Graphics Modules	5
2	VGA-Enable Jumper	6
3	ZLXp-L Installation	12
4	Properties for PVP.DLL	16

Tables

1	Digital UNIX and OpenVMS Alpha Order Numbers	3
2	Windows NT Order Numbers	4
3	Compatible Software Versions	4
4	VGA Enable/Disable	6
5	Monitor Values	7
6	ZLXp-L1 and ZLXp-L2 PCI Weight and Dimensions	20
7	Environmental Specifications	20
8	Power Consumption Specifications	21
9	Cable	22
10	Field Replaceable Units (FRUs)	23

Guide Overview

Purpose	<p>This guide provides general information about the ZLXp-L1 (PBXGC-AA/AN) and ZLXp-L2 (PBXGC-BA/BN) graphics accelerator modules. This information is independent of the hardware platform. For specific information about your hardware platform, refer to your system documentation.</p> <p>Additionally, this guide provides the software installation information for the ZLXp-L series display driver used with the ZLXp-L1 and ZLXp-L2 graphics modules (Microsoft® Windows NT™ systems only).</p>
Audience	<p>This guide is for anyone requiring general information on the ZLXp-L modules and the ZLXp-L Display Driver software, and for Digital service personnel seeking specific service information.</p>
Contents	<p>This guide provides the following information:</p> <ul style="list-style-type: none">• Description of the modules• Setting VGA enable/disable jumper• List of monitors• Module installation• ZLXp-L series display driver software• Confirming proper installation• Stereo viewing• Module specifications• Cabling information• Field Replaceable Units (FRU)

Conventions

The following conventions are used in this guide:

ZLXp-L Display Driver	The name for the Windows NT display driver used with both the ZLXp-L1 and ZLXp-L2 graphics modules.
<code>Return</code>	A key name is shown enclosed to indicate that you press the named key on the keyboard.
CAUTION	Cautions provide information to prevent damage to equipment or software. Read these carefully.
Note	Notes contain additional information that you should be aware of.
Digital UNIX	This designation represents the Digital UNIX operating system.
Windows NT	Refers to the Microsoft® Windows NT™ operating system software.

Reader's Comments

Digital welcomes your comments on this or any other manual. You can send your comments to Digital in the following ways:

- Internet electronic mail: readers_comment@zk3.dec.com
- Mail:

Digital Equipment Corporation
Shared Engineering Services
PKO3-2/29K
129 Parker Street
Maynard, MA 01754-2195

Description of the Modules

Purpose

The ZLXp-L1 and ZLXp-L2 PCI graphics modules are PCI local bus devices that use ZLXp-L device driver software, to generate high-resolution, 2- and 3-dimensional color graphics for use on Digital AlphaStation systems. Application programs can use the module's graphic capabilities to render mechanical CAD, molecular modeling, visualization, and other graphical information.

The ZLXp-L1 module is a single-PCI-slot graphics module with a long-card form factor. The ZLXp-L2 module is a two-PCI-slot graphics module with an expansion module connected to the component side of the ZLXp-L1 module. Stereo viewing is provided with both modules. The ZLXp-L devices currently support a single-head configuration.

ZLXp-L1 and ZLXp-L2 Module Information

Table 1 lists the order numbers of modules used with the Digital UNIX and OpenVMS Alpha operating systems.

Table 1 Digital UNIX and OpenVMS Alpha Order Numbers

Module Designation	Order Number	Rendering Engines	Graphics Memory	Planes	Slots Used
ZLXp-L1	PBXGC-AA	1	16MB	24	1
ZLXp-L2	PBXGC-BA	2	32MB	24	2

Description of the Modules

Table 2 lists the order numbers of modules used with the Windows NT operating system.

Table 2 Windows NT Order Numbers

Module Designation	Order Number	Rendering Engines	Graphics Memory	Planes	Slots Used
ZLXp-L1	PBXGC-AN	1	16MB	24	1
ZLXp-L2	PBXGC-BN	2	32MB	24	2

Your shipment includes the following items:

- ZLXp-L1 or ZLXp-L2 module
- *ZLXp-L1 and ZLXp-L2 PCI Graphics Options Owner's Guide*, order number EK-PVPCI-OG (this book)
- Antistatic wrist strap
- Ferrite bead assembly

Software

The ZLXp-L1 and ZLXp-L2 PCI graphics modules are compatible with the minimum software versions listed in Table 3.

Table 3 Compatible Software Versions

Designation	Digital Open3D	Digital UNIX	OpenVMS Alpha	Windows NT
ZLXp-L1	V3.0, 3.1, 3.2	V3.2, V3.2a, V3.2b, V3.2c, V3.2d	V6.1-1H2, V6.2, V6.2D	WNT 3.51
ZLXp-L2	V3.0, 3.1, 3.2	V3.2, V3.2a, V3.2b, V3.2c, V3.2d	V6.1-1H2, V6.2, V6.2D	WNT 3.51

Warranty

The product warranty conforms to the system in which you install the graphics module. For example, a 3-year warranty means 1-year on-site coverage and 2-year return-the-defective part to Digital coverage.

Description of the Modules

Description The ZLXp-Lx graphics modules are shown in Figure 1.

Figure 1 ZLXp-L1 and ZLXp-L2 Graphics Modules

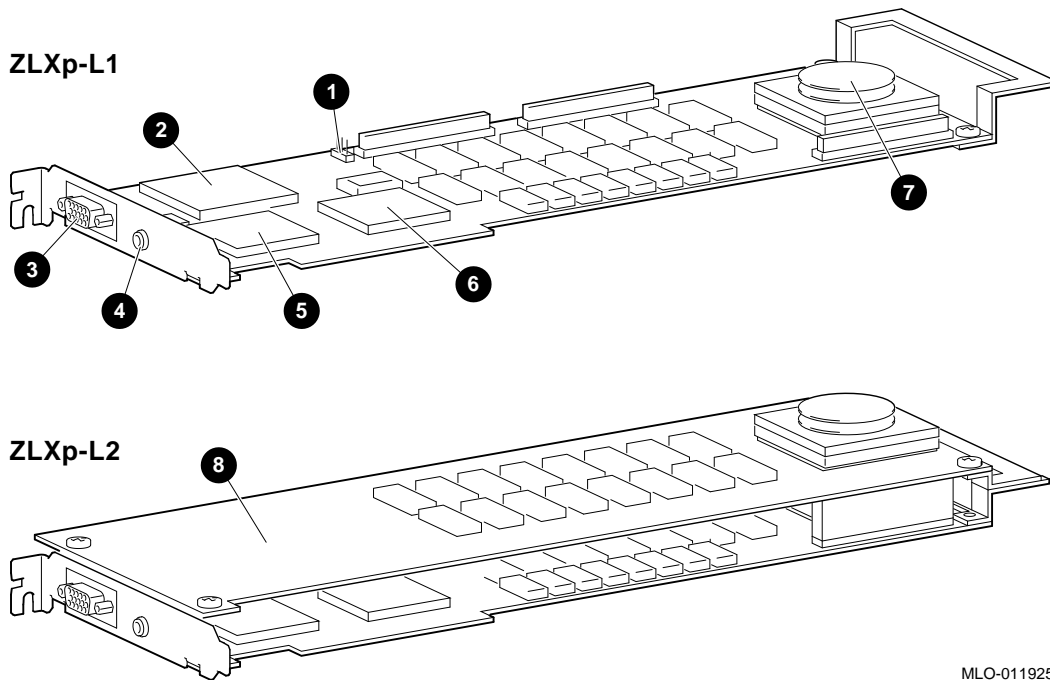

MLO-011925

- ❶ ZLXp-L1 — VGA-enable jumper
- ❷ ZLXp-L1 — RGB RAMDAC chip
- ❸ ZLXp-L1 — Video port
- ❹ ZLXp-L1 — Stereoscopic viewing port
- ❺ ZLXp-L1 — VGA chip
- ❻ ZLXp-L1 — Pixelvision interface
- ❼ ZLXp-L1 — Rendering chip
- ❽ ZLXp-L2 — Two module set with expansion module connected to component side of the ZLXp-L1 module

Setting the VGA Jumper

The ZLXp-L1 and ZLXp-L2 PCI graphics modules contain one configurable part, a VGA-enable jumper. Enabling VGA allows the software to use the same monitor for VGA console display and for 3D graphics. To set the VGA-enable jumper, hold the module with the goldfingers facing you. See Figure 2 and the figure description in Table 4.

Table 4 VGA Enable/Disable

Position	VGA Enable /Disable	Description
①	Enable	Place the VGA jumper on the two pins closest to the module edge.
②	Disable	Place the VGA jumper on the two pins closest to the center of the module.

Figure 2 VGA-Enable Jumper

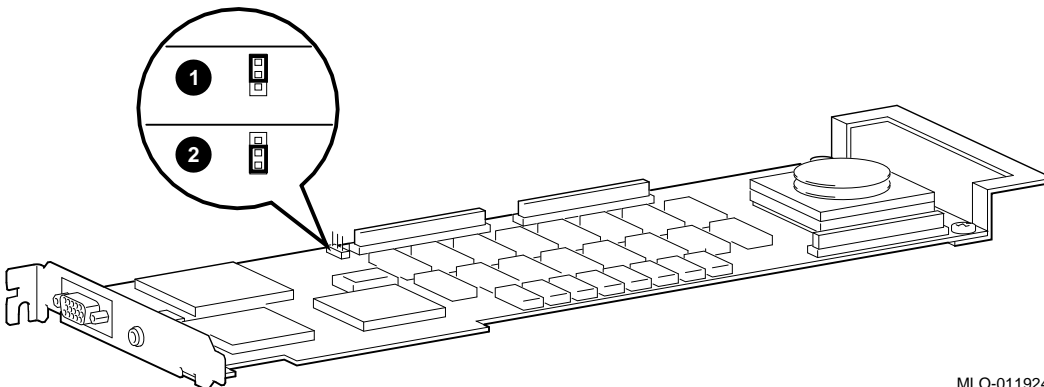

MLO-011924

Monitor Values

Table 5 lists the model numbers of the monitors used with the ZLXp-Lx modules, the monitor resolutions, and refresh rates.

Table 5 Monitor Values

Monitor Resolution (Pixels)	Refresh Rate (Hz)	Monitor Model
1280x512†	139	VRC21-HA/H4/PA/P4
1280x1024	72‡	VRT17-HA/PA/P4, VRC21-HA/H4/PA/P4, VRC17-JA/J4
1024x768	72	VRC15-PA/P4, VRT17-HA/H4/PA/P4, VRC21-HA/H4/PA/P4, VRC17-JA/J4
800x600	72	VRC15-PA/P4, VRT17-HA/H4/PA/P4, VRC21-HA/H4/PA/P4, VRC17-JA/J4
800x600	60	VRC17-JA/J4, VRC21-HA/H4/PA/P4
640x480	72	VRC15-PA/P4, VRT17-HA/H4/PA/P4, VRC21-HA/H4/PA/P4, VRC17-JA/J4
640x480	60	VRC15-PA/P4, VRT17-HA/H4/PA/P4, VRC21-HA/H4/PA/P4, VRC17-JA/J4

†For stereoscopic viewing

‡Initial support is for 1280x1024 resolution, at 72 Hz refresh rate, on the specified monitors. Watch your *Digital Open3D for Digital UNIX Release Notes* for update notices.

Installing the ZLXp-L Display Driver Software

Software Overview

The ZLXp-L1 and ZLXp-L2 software is a Digital Display Driver compatible with the Microsoft® Windows NT™ operating system software. It includes the following:

- ZLXp-L series display driver software for the ZLXp-L1 and ZLXp-L2 graphics modules.
- Release Notes (on installation floppy Disk 1), located in `relnotes.wri`. The release notes can be read by using the Write application in Windows NT, which you access by selecting the Program Manager icon, the Accessories program group, and the Write application.

The ZLXp-L1 and ZLXp-L2 Display Driver package contains this manual and distribution floppies.

System Requirements

The ZLXp-L driver software requires a system with an Alpha CPU, and a PCI bus running the Microsoft Windows NT operating system, Version 3.5 or 3.51.

Installation Procedure

To install the ZLXp-L1 and ZLXp-L2 Display Driver, perform the following steps:

1. Boot your system and log into Microsoft Windows NT.
2. In drive A, insert the floppy disk provided with your ZLXp-L module.
3. Select the Program Manager icon.
4. From Program Manager, choose the Main program group.
5. From Main, choose Control Panel.
6. From Control Panel, choose Display.

Installing the ZLXp-L Display Driver Software

7. From Display Settings, choose Change Display Type to see a list of display options.
8. From Display Type, choose Change Adapter Type to list the available Display Drivers.
9. From Select Device, choose Other.
10. From Install from Disk, you are asked to insert the manufacturer's installation disk. You inserted the floppy provided with the ZLXp-L module in Step 2; therefore, you need only enter the letter of the disk drive (for example, A:\ for A drive) and choose OK.
11. The Select Device dialog box listing in the ZLXp-L Display Driver options is displayed. Select the option that you are installing (usually appears at the bottom of the options list) and choose Install.
12. A dialog box stating that this operation will change your system configuration may be displayed. Choose Yes to proceed.
13. You are not prompted for the full path of the Display Driver files. The appropriate path should already be displayed; for example, A:\ for an installation from disk drive A. If the path indicated is incorrect, enter the correct path information and press .
14. Choose continue. The driver files are copied to your disk.
15. When all driver files have been copied, you should see a dialog box indicating that the driver was successfully installed. Choose OK to complete the installation.
16. When prompted by Windows NT to restart the system, remove the floppy disk from the disk drive. If you wish to restart your system immediately, select Restart Now.
17. Shut down your system so that you can install the ZLXp-L1 and ZLXp-L2 module. Then reboot your system to access the new driver. The blue screen with the Windows NT logo will display on the monitor.

Installing the ZLXp-L Display Driver Software

Texturing Speed vs Texturing Precision

After you install the ZLXp-L* driver and reboot the system, you may select between speed in texturing and precision in texturing. At initial installation, the driver is configured to fast texturing. The driver can be reconfigured to use higher levels of precision in various parts of the texture pipeline, but texturing will not be as fast. To change the driver to set the higher levels of precision, follow these steps:

1. From the File Manager File menu, select RUN. At the command line, type the following command:

```
REGEDT32
```

2. Open the HKEY_LOCAL_MACHINE folder
3. Open the SYSTEM folder
4. Open the CurrentControlSet folder
5. Open the Services folder
6. Open the pvp folder
7. Open the Device0 folder
8. Select the Edit menu's Add Value option
9. Type in the Value Name: DP_TextureFastest
10. Select the Data Type: REG_DWORD
11. Press the OK button
12. Enter the Data: 0
The default is 1—fast textures, if there is no entry.
13. Press the OK button
14. Exit the registry
15. Reboot your system

Installing the Module

Procedure

Follow these easy-to-do steps to install a ZLXp-L1 or ZLXp-L2 graphics module.

Note

Each step presumes that you are familiar with your hardware platform. For specific information regarding your hardware platform, refer to your system documentation.

1. Turn off the system and any external devices. Disconnect any external devices and unplug the power cord from the wall outlet.
2. Remove the system unit cover, unscrew and remove the metal filler plate that may be present for the PCI slot you have selected. Save the screw that secured the metal filler plate.
3. Set the VGA-enable jumper using Figure 1 and Table 4 as reference. The installed orientation of the graphics module varies from system to system; therefore, set the VGA jumper before you install the module, to ensure that you have the correct setting.

CAUTION

To avoid damage to the module from static discharge, wear an antistatic wrist strap when you handle the module. Instructions for using the wrist strap are on the strap's envelope.

Installing the Module

4. Insert the ZLXp-L1 or ZLXp-L2 graphics module ❶ into an available option slot. Figure 3 illustrates the ZLXp-L1 module being installed. The ZLXp-L2 module is installed in the same manner.

Figure 3 ZLXp-L Installation

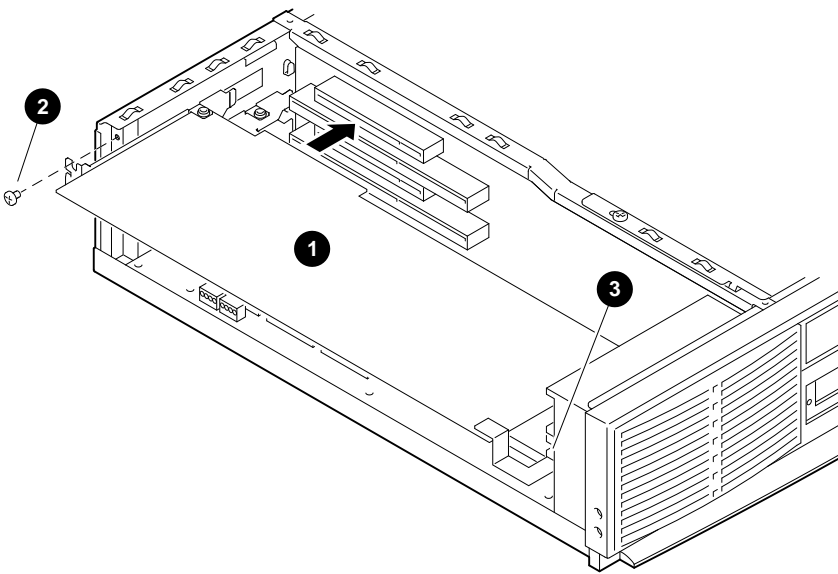

MLO-011923

5. Check to see that the module extender bracket is located in the system PCI card guide ❸.
6. Insert the screw ❷, and secure the module to the enclosure.
7. Replace and secure the cover to the system unit. Attach all external devices and cables that were previously removed.

8. Connect the video cable to the ZLXp-Lx video port.
9. Connect the optional stereo cable to the stereoscopic viewing port.

————— **Important** —————

The video and stereo cable ports should be connected with only shielded data cables with an external ferrite bead over the cable. When either of these ports is connected with a cable without such a ferrite bead, then clamp the ferrite bead provided in your parts kit on the video or stereo cable next to the cable connector.

10. Connect your video monitor as described in your system documentation.

**Confirming
Proper
Installation**

To confirm that the module is installed properly, follow these steps:

1. Turn on the monitor and any other devices connected to the system unit.
2. Turn on the system unit.
3. Verify that the console display is available and legible on the monitor screen.

Successful Installation:

The console display is available and no errors are reported.

Unsuccessful Installation:

Errors are reported on the console. Reseat the module. If errors are still reported, follow the steps outlined in the Troubleshooting section.

**Reboot the
System**

Reboot your system to access the new driver. The blue screen with the Windows NT logo will display on the monitor.

Installing the Module

Setting the Screen Resolution and Refresh Rate

After you install the ZLXp-L module and reboot the system, you can change the screen resolution or refresh rate (collectively referred to as the display mode.) Before changing the display mode, you must confirm that your monitor can handle the new values. Follow these steps:

1. Log into your Windows NT system.
2. From Program Manager, choose the Main program group.
3. From Main, choose Control Panel.
4. From Control Panel, choose Display.
5. From Display, click on the arrows in the Desktop Area to change the screen resolution. To change the refresh rate, choose one of the options in Refresh Frequency. (You can also change the resolution and refresh rate by choosing List All Modes and the desired mode, and then choosing OK). If the refresh rate selected is not supported by the resolution you chose, the resolution will automatically change to the nearest value supported by that refresh rate, or the refresh rate will change to support the resolution.
6. Choose Test to verify that the settings work correctly. A test pattern will be displayed on your monitor for about five seconds.
7. You will now see the question *Did you see the bitmap test properly?* If you are satisfied with the video display, choose Yes.
8. Shut down and reboot your system. The blue screen with the Windows NT logo will display on the monitor.
9. You may have to adjust your monitor to align the new resolution to the monitor. This is typically done by using the control knobs on the front or side of the monitor.

Identifying the Display Driver Version

To report problems with the ZLXp-L Display Driver, you must include the version of the display driver with your description of the problem. To identify the version of the display driver, perform the following steps:

1. From the File Manager, locate the `pvp.dll` file. It is typically found in `\winnt35\system32`.
2. Choose this file and highlight it by clicking once on the filename.
3. From the File menu, choose Properties. File Manager then displays a dialog box, see Figure 4.

Installing the Module

Figure 4 Properties for PVP.DLL

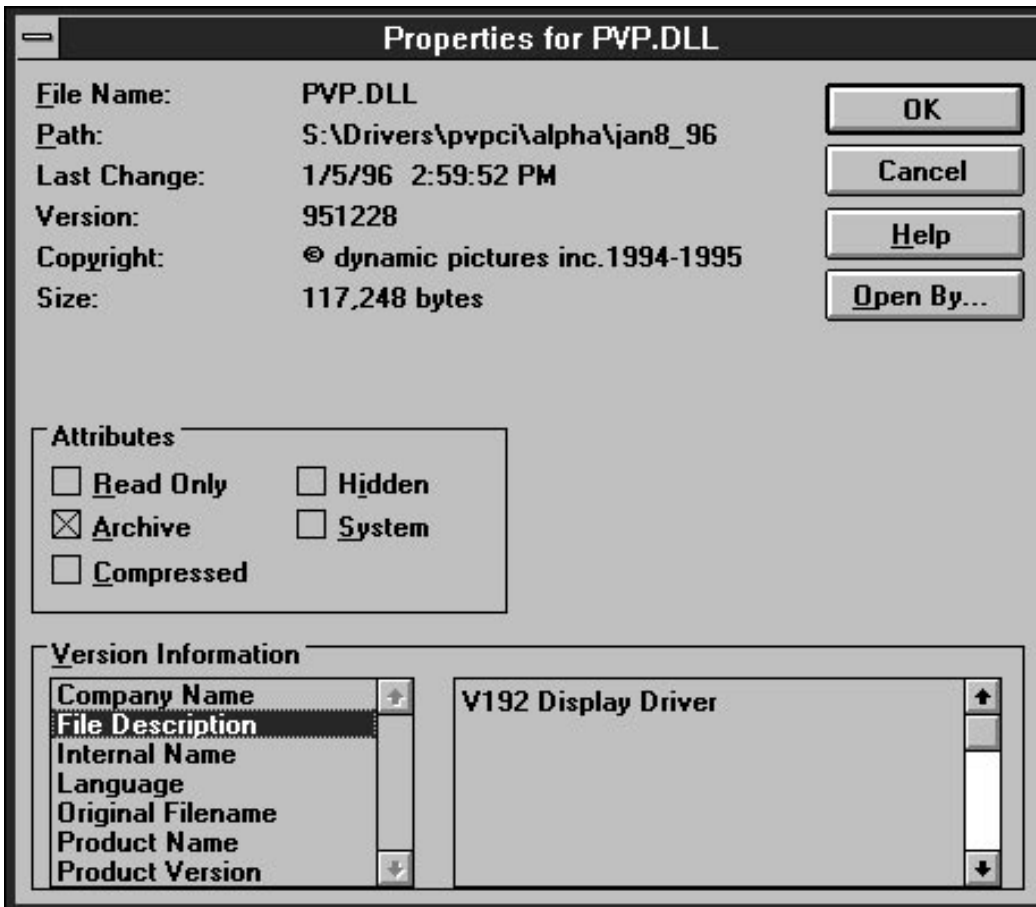

4. In the Version Information box at the bottom of the display, choose File Description from the list. The edit control box on the right will display a string containing the driver name (in this example, V192 Display Driver, the date, and an optional class stamp.)

Troubleshooting

If the console display does not appear on the monitor screen after you install the module and power up your system, follow these steps:

1. Verify that the power cord for the system and all related devices are plugged into a live wall socket and that all devices are on.
2. Ensure that the video and optional stereo cables and connections are secure.
3. Verify that the video cable is properly secured to the ZLXp-Lx video port and video monitor.
4. Verify that the module is seated correctly in the PCI slot.
5. Verify that the VGA-enable jumper has been set, and that there are no other VGA options installed.
6. Verify that the video monitor brightness and contrast controls are properly set.

Installing the Module

**Handling
Problems
Worksheet**

If you have a problem, please fill in the following information before calling for assistance. The information helps your Digital representative to identify the problem quickly.

System Name and Model Number: _____

System Serial Number: _____

Module Part Number: _____

Operating System & Version: _____

Digital Open3D software version: _____

Monitor Name/Model Number: _____

VGA Jumper Setting: _____

Error Received: _____

Stereo Viewing

- Description** StereoGraphics, a leading manufacturer of true stereo viewing systems, produces equipment to allow stereo viewing applications to work with your ZLXp-L1 and ZLXp-L2 PCI graphics modules.
- For more information, contact:
- StereoGraphics
2171 East Francisco Boulevard
San Raphael, California 94901
U.S.A.
Telephone: 415-459-4500
FAX: 415-459-3020
- Stereo Cable** A special 3-meter (10-foot) stereo cable is required for the ZLXp-L1 and ZLXp-L2 graphics modules. The StereoGraphics order number for this cable is DEC 69990 and has the following description: DEC EMITTER CABLE MINI-STEREO TO BNC MST-BNC.
- Stereo Monitor** Stereo viewing requires that the video monitor support a special stereo frequency mode. The VRC21-HA/H4/PA/P4 video monitors support this special stereo mode. Video monitors from other vendors can also support the special stereo mode.

Appendix A — Module Specifications

Physical Specifications

Table 6 lists the physical specifications of the modules.

Table 6 ZLXp-L1 and ZLXp-L2 PCI Weight and Dimensions

Module	Weight	Length	Width	Height (Side 1)	Height (Side 2)
ZLXp-L1	1.0 lbs	13 in (330.2 mm) including bulkhead	4.2 in (106.68 mm)	.5 in (12.7 mm)	.105 in (2.67 mm)
ZLXp-L2	1.2 lbs	12.283 in (312 mm) no bulkhead	4.2 in (106.68 mm)	.5 in (12.7 mm)	.625 in (15.86 mm) including connectors

Environmental Specifications

Table 7 lists the environmental specifications for the modules.

Table 7 Environmental Specifications

Temperature range	10°C to 40°C (50°F to 104°F)
Temperature change rate	11°C/hr (20°F/hr) maximum
Relative humidity	5% to 95% noncondensing
Maximum wet bulb temperature	28°C (82°F)
Minimum dew point	2°C (36°F)
Altitude	2400 m (8000 ft) at 36°C (96°F)

**Power
Consumption**

The ZLXp-L1 graphics module power consumption is 25.0 watts or less. The ZLXp-L2 graphics module power consumption is 50.0 watts or less.

Table 8 lists the measured current draw at both positive and negative supply voltages for both modules.

Table 8 Power Consumption Specifications

Supply (Volts)	Consumption (Amps)
+5 +/-5%	4.75
+3.3 +/-5%	0
+12 +/-5%	0
-12 +/-15%	0

Appendix B — Cables

Cabling Information

Table 9 lists the cable that you can use with the ZLXp-L1 and ZLXp-L2 PCI graphics modules.

Table 9 Cable

Designation	Order Number	Length
BC13L-10	30-34761-03	3 meters (10 feet)

Note

The BC13L-10 cable is normally shipped with the video monitor from Digital Equipment Corporation. However, the cable does *not* ship with the VRC21-HA/H4 video monitors. Installations using a VRC21-HA/H4 monitor *must* order the BC13L-10 video cable separately.

Appendix C — FRUs—For Digital Service

Ordering FRUs

Table 10 lists the field replaceable units (FRUs) for Digital service representatives to order.

Table 10 Field Replaceable Units (FRUs)

FRUs	Part Number
ZLXp-L1 module (PBXGC-AA/AN)	70-32300-01
ZLXp-L2 module (PBXGC-BA/BN)	70-32301-01
Antistatic wrist strap	12-36175-01
Ferrite bead assembly	16-25105-18

Index

C

- Cable
 - special order, 22
- Conventions
 - used in this guide, 2

D

- DOC compliance
 - statement of, iv
- Driver
 - description of, 8
 - installation of, 8
 - reboot system to access, 13
 - system requirements for installation, 8
 - version of, 15

E

- EMI
 - statement, iv

F

- FCC notice, iii
- FRUs
 - order numbers for, 23

I

- Installation
 - confirmation of, 13
 - display driver software, 8
 - figure of, 12
 - software procedure, 8
 - step-by-step, 11
 - troubleshooting problems, 17

J

- Jumper
 - enabling VGA, 6
 - VGA-Enable, figure of, 6

M

- Modules
 - description of, 3, 5
 - figure of L1/L2, 5
 - installing, 11
 - purpose of, 3
 - software compatibility, 4
 - version, 3
 - warranty information, 4
- Monitor values, 7

O

- Overview
 - conventions used, 1
 - purpose of document, 1

P

Precision

texturing, 10

Problems

suggestions for solving, 17

R

Reboot system

to access driver, 13

Refresh

setting rate, 14

Resolution

setting rate, 14

S

Service information

for Digital service, 23

FRU order numbers, 23

Software

compatible versions, 4

Specifications

cables, 22

environmental, 20

hardware, 20

physical, 20

power consumption, 21

Speed

texturing, 10

Stereo cable

use with graphics option, 19

Stereo monitor

use with graphics module, 19

Stereoscopic viewing, 19

Stereo viewing

description of, 19

stereo cable, 19

T

Texturing

speed vs precision, 10

Troubleshooting

installation problems, 17

worksheet, 18

V

VGA-Enable jumper

figure of, 6

setting, 6

W

Warranty information, 4

Worksheet

handling problems, 18