

OVERVIEW

The CL-GD7555 is the first product in a new family of 64-bit GUI and video-accelerated LCD/CRT controllers. It distinguishes itself by offering top 64-bit graphics performance while delivering superb video quality with its trend-setting video-color adjustment, MVA features, and scaling engine with EST (edge sharpening technology). With on-chip video-acceleration features and V-Port™ support, the CL-GD7555 is an extremely flexible and cost-effective multimedia solution for premium portable computer designs. The CL-GD7555 surpasses desktop-system equivalency by providing 'desktop-replacement' performance, features, and display mode support for the office.

FEATURES

■ True 64-bit acceleration

- 64-bit BitBLT acceleration engine
- 64-bit display memory interface
- 64-bit data paths

■ GUI acceleration

- BitBLT setup register double buffering with autostart
- Transparent BitBLT (source color key)
- Memory-mapped I/O
- True packed-pixel addressing for 8, 16, and 24 bpp

■ Direct-connect 32-bit PCI v2.1 host bus interface

- Multiple apertures to support simultaneous high-performance graphics and video
- Extended burst cycle and automatic bus retry support for high data transfer rates

64-Bit Video- and Graphics-Accelerated LCD/CRT Controller

■ Enhanced video acceleration

- X and Y interpolating scaling engine
- EST – Edge-sharpening option with upscaling
- Continuous video upscaling to 1024 × 768
- Easy, independent end-user control of color, brightness, and contrast of the video window to compensate for gamma/color characteristics of the display and media
- DirectDraw™/DirectVideo™ (Windows® 95) and DC11.X (display control interface for Windows® 3.X) support for full-motion video playback acceleration
- Integrated color space converter for 4:2:2 YCrCb to RGB 8:8:8
- Hardware destination color- and chroma-key support (hardware occlusion)
- V-Port™ and VPM (video port manager) support for PC Card ZV-Port specification
- Acceleration of MPEG-1, True Motion™, CinePak™, and Indeo™ software-coded video
- Video format support for 24- and 16-bpp RGB, 4:2:2 YCrCb, and proprietary compressed formats – AccuPak™ and DYUV 8-bpp YCrCb

■ Scalable, high-performance memory interface

- 64-bit interface supporting 1 and 2 Mbytes
- Optimized for EDO (extended-data-out) DRAM
- Single design can support 2-Mbyte (four 256K × 16) and 1-Mbyte (four 128K × 16) memory configurations

(cont.)

System Block Diagram

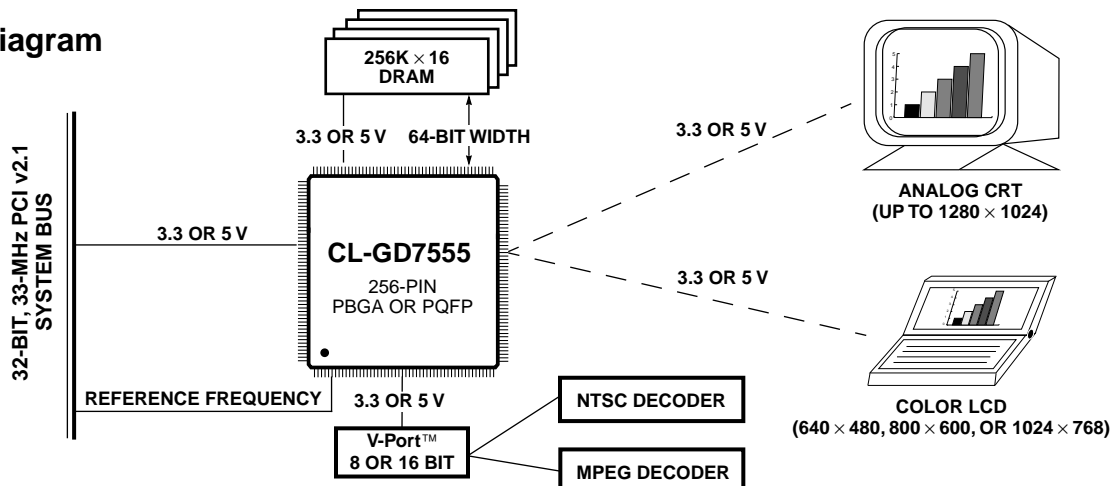

FEATURES (cont.)

Portable-Specific Features

■ Display device support

- TFT: 1024 × 768 (XGA), 800 × 600 (SVGA), 640 × 480 (VGA)
- DSTN: 800 × 600, 640 × 480
- CRT: 1280 × 1024, 1024 × 768, 800 × 600, 640 × 480

■ Flat panel-specific support

- Color TFT flat panels:
 - 1-pixel/shift clock (9-, 12-, 18-, and 24-bit interfaces);
 - 2-pixel/shift clock (18-bit direct-connect interface)
- Enhanced hardware expansion of lower-resolution VGA display modes up to 800 × 600 on higher-resolution flat panels
- Automatic centering of lower-resolution VGA display modes on higher-resolution flat panels
- Dithering algorithm automatically adds up to 8 bits per primary color without decreasing resolution
- Enhanced frame-rate modulation algorithm improves display quality with fast-response DSTN flat panels

■ Integration

- 24-bit true-color palette and DAC with support for gamma/color adjustment in High- and True-Color modes
- Programmable frequency synthesizer:
 - 80-MHz VCLK and 66-MHz MCLK at 3.3 V;
 - 135-MHz VCLK and 80-MHz MCLK at 5 V

■ Power-management capabilities

- 3.3-V, 5-V, and mixed-voltage operation
- Active power management provides power-down control of select unused internal functional blocks during display
- Suspend and Standby mode support
- VESA[®] DPMS (display power management signaling) support
- DDC-2B (display data channel) support

■ Packaging

- 256-pin PBGA (plastic ball grid array) 27 mm × 27 mm
- 256-pin PQFP (plastic quad flat pack) 28 mm × 28 mm

PRODUCT DESCRIPTION

The outstanding GUI performance of the CL-GD7555 is accomplished with 64-bit architecture (64-bit BitBLT engine, memory interface, and data paths), and an ability to effectively eliminate setup latency during BitBLT operations by double-buffering BitBLT setup registers. In addition, optimizing support for the burst capabilities of PCI v2.1 (with multiple apertures, extended burst cycle support, auto bus retry, and a properly sized write buffer) boosts CL-GD7555 performance in all environments.

With its MVA (MotionVideo™ Acceleration) features, the CL-GD7555 leads the industry in multimedia video quality. In addition, the CL-GD7555 provides graphics color/brightness correction and a powerful scaling engine with EST (edge-sharpening technology). The color/brightness adjustment allows the CL-GD7555 to compensate for color and brightness variations of display devices (for example, TFT, DSTN, CRT, TV), resulting in consistent image display on various display devices and from various sources.

The CL-GD7555 allows separate end-user color and brightness adjustment of the video window, independent of the overall display (the first portable graphics controller to offer this feature). This adjustment is important, because almost all recorded video (including video recorded by camcorders) is gamma pre-corrected for a TV display. The end user can adjust the color and brightness of the video window in much the same way as it can be adjusted on a color TV. The end user can compensate for both the characteristics of the specific display device to be used and for loss of color fidelity

caused by video recording, compression, and decompression.

To support multimedia special effects, the CL-GD7555 provides hardware occlusion (destination color/chroma keying) and transparent BitBLT (source color/chroma keying). Windows[®] 95 and DirectDraw™ emulate these functions in software; however, DirectDraw can recognize and use hardware support for these operations, greatly accelerating them.

The CL-GD7555 also offers flexibility for implementation. V-Port support allows cost-effective implementation of many multimedia features (MPEG video playback, TV tuner, video capture, and teleconferencing). These V-Port-related functions can be implemented on the motherboard or added later as ZV-Port-enabled PC Cards.

In most high-end implementations, the CL-GD7555 is likely to be implemented with a 2-Mbyte frame buffer using four 256K × 16 DRAMs. However, a more cost-effective mid-range 1-Mbyte product can be implemented using the same board design and replacing the four 256K × 16 DRAMs with four pin-compatible 128K × 16 DRAMs. The graphics benchmark performance of the 1-Mbyte configuration is the same, but fewer modes are supported.

To summarize, the CL-GD7555 is an industry-leading portable graphics solution with exceptional graphics performance and superb video quality, allowing much flexibility in implementation.

FEATURES	CL-GD7555	BENEFITS
Performance		
■ Winmark® 95 expectation (Pentium® 166, Windows® 95, Winbench 96)	>30M Winmarks	<input type="checkbox"/> Better end-user responsiveness.
■ BitBLT engine	Second-generation 64-bit	<input type="checkbox"/> Proven core design and driver base.
■ Transparent BitBLT	✓	<input type="checkbox"/> Enhances Windows® 95 game performance; enables non-rectangular BitBLTs.
■ Memory-mapped I/O	✓	<input type="checkbox"/> Improves performance by reducing host CPU cycles.
■ Double-Buffer BitBLT registers (BitBLAST)	✓	<input type="checkbox"/> Allows one BitBLT register to be set up while another BitBLT register is executing; eliminates BitBLT setup latency.
■ Optimized PCI host interface	PCI v2.1; 33 MHz	<input type="checkbox"/> High-performance industry-standard interface.
■ PCI bus retry	✓	<input type="checkbox"/> Automatically monitors the bus for an opening to transmit multimedia data.
■ Multiple PCI apertures	✓	<input type="checkbox"/> Accelerates PCI bus master video transfers. Dedicated aperture for multimedia use, while other apertures service normal PCI traffic.
■ Optimized write buffer	32-bit × 8-level-deep	<input type="checkbox"/> Sized to optimize PCI burst bandwidth.
■ Burst support	✓	<input type="checkbox"/> Significantly enhances PCI bandwidth.
■ Proprietary FasText™ text acceleration	✓	<input type="checkbox"/> Maintains true VGA compatibility (two fonts in plane 2). <input type="checkbox"/> Enables high refresh rate in text display modes with 800 × 600 DSTN flat panels.
Multimedia Video		
■ ZV-Port (V-Port™)	✓	<input type="checkbox"/> Allows flexible after-market multimedia upgrade of portable PCs. <input type="checkbox"/> Off-loads video bandwidth from the PCI bus, which improves system performance.
■ Independent color adjustment of graphics display and video window; independent brightness control of video window	✓	<input type="checkbox"/> Normalizes color fidelity between vendor's flat panels and other display device types. <input type="checkbox"/> Allows end user to adjust color and brightness to their preference in the video window and the graphics background.
■ Hardware source (transparent BitBLT) and destination (occlusion) color and chroma key support to 1024 × 768	✓	<input type="checkbox"/> Allows video data to maintain frame data rate when video window is occluded by graphics data. <input type="checkbox"/> Required to accelerate video in Windows® 95 games. <input type="checkbox"/> Source and destination color and chroma key support complies with DirectDraw™ specification.
■ Continuous X and Y interpolated scaling to 1024 × 768, scaling option to use algorithm that maintains edge sharpness during upscaling	✓	<input type="checkbox"/> Smooth upscaling of video up to 1024 × 768 while reducing image aliasing (that is, blockiness of image). <input type="checkbox"/> Reduces host CPU bandwidth by off-loading scaling function to graphics controller. <input type="checkbox"/> Greatly reduces PCI and memory bandwidth by transferring video in its native resolution (352 × 240 rather than 1024 × 768).
■ Color space conversion	✓	<input type="checkbox"/> Converts 16-bpp YUV to 24-bpp true-color RGB. <input type="checkbox"/> Converts compressed 8-bpp AccuPak™ or DYUV to high-color RGB. <input type="checkbox"/> Frees host CPU, PCI, and memory bandwidth, which would otherwise be required for color space conversion.
■ Frame buffer support for mixed formats and color depth	✓	<input type="checkbox"/> RGB, YUV, AccuPak™, and compressed YUV can coexist in the frame buffer — important because YUV, AccuPak™, and compressed YUV are more efficient formats for memory size and bandwidth. <input type="checkbox"/> Allows the color depth of video to be independent of background graphics color depth, reducing memory and bandwidth requirements for quality video.

FUNCTIONAL BLOCK DIAGRAM

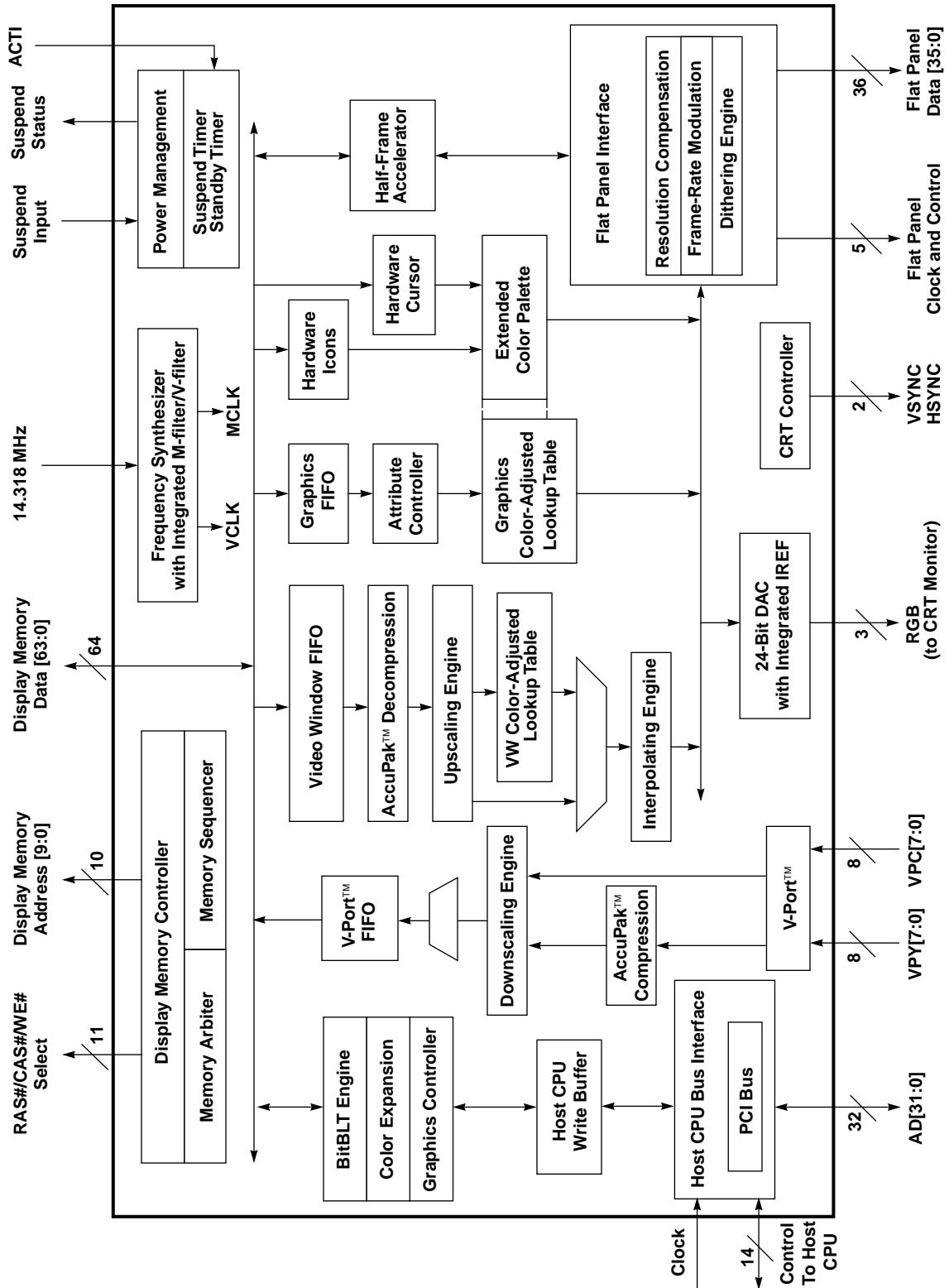

SOFTWARE SUPPORT

Operating System and Application Software Drivers

Software Drivers ^a	Resolution Supported	
Microsoft® Windows® v3.X Microsoft® Windows® 95	CRT Only	640 × 480, 800 × 600, 1024 × 768, 1280 × 1024
	SimulSCAN™	640 × 480, 800 × 600, 1024 × 768
Microsoft®/Intel® DCI™	SimulSCAN	640 × 480, 800 × 600, 1024 × 768
DirectDraw™/DirectVideo™ for Windows® 95 Includes low-resolution support for game applications	SimulSCAN	320 × 200, 320 × 240, 512 × 384, 640 × 400, 640 × 480, 800 × 600, 1024 × 768
Cirrus Logic VPM (video port manager) for ZV-Port and V-Port™ solutions	SimulSCAN	640 × 480, 800 × 600, 1024 × 768
Microsoft® Windows NT™ v3.5X	SimulSCAN	640 × 480, 800 × 600, 1024 × 768
OS/2®, WARP 4.0	CRT Only	640 × 480, 800 × 600, 1024 × 768, 1280 × 1024
	SimulSCAN	640 × 480, 800 × 600, 1024 × 768
AutoCAD® v11, v12, Autoshade® v2.0, 3D Studio® v1, v2	CRT Only	640 × 480, 800 × 600, 1024 × 768, 1280 × 1024
	SimulSCAN	640 × 480, 800 × 600, 1024 × 768

^a Driver support for additional applications is provided by independent software vendors, either with specific drivers or through VESA® mode support. For more information concerning driver support, contact the software manufacturer.

BIOS

Feature	Benefit
■ 48-Kbyte VGA BIOS	<input type="checkbox"/> Provides optimum performance with VGA and VESA® extended display mode support. <input type="checkbox"/> Provides system design options for the best combination of performance and functionality.
■ Fully IBM®-compatible VGA BIOS	<input type="checkbox"/> Compatible with the existing base of PC applications.
■ VESA® VBE (VGA BIOS extensions) v1.2, DDC-2B, and power management	<input type="checkbox"/> Compatible with industry standards for extended display mode support beyond VGA, intelligent monitor sensing, and power-management control.

Software Utilities

Utility	Function
Windows® 95 utilities	Windows® 95 utilities (Available in various foreign-language translations.) – Refresh rate selection – Display device selection; Panel, CRT, SimulSCAN, TV(NTSC/PAL)
WinMode and CLMode	Windows® 3.X and DOS utilities (available in various foreign-language translations) for configuration of graphics display modes and display device type.
REG7555	Windows®-based VGA register viewer/editor and V-Port™/video window display-configuration utility for OEM development use.
OEMSI	VGA BIOS-customization utility for OEM development use.
PCLRegs	DOS-based VGA register viewer/editor for OEM development use.
Color balance utility for color and brightness adjustment	End-user utility allowing color and brightness adjustments of both the graphics CLUT and the video-window CLUT to compensate for both the color/brightness variations of the display device, and any color fidelity variations in the video media being displayed.

Ordering Part Number:

CL-GD7555 – 135BC

Where:

B = Ball-Grid Array Package

C = Commercial Temp. (0°C to 70°C)

Direct Sales Offices

Domestic

N. CALIFORNIA

Fremont
TEL: 510/623-8300
FAX: 510/252-6020

S. CALIFORNIA

Irvine
TEL: 714/453-5961
FAX: 714/453-5962

Westlake Village
TEL: 805/371-5860
FAX: 805/371-5861

SOUTH CENTRAL AREA

Austin, TX
TEL: 512/255-0080
FAX: 512/255-0733

Dallas, TX
TEL: 214/252-6698
FAX: 214/252-5681

Houston, TX
TEL: 281/257-2525
FAX: 281/257-2555

NORTHEASTERN AREA

Andover, MA
TEL: 508/474-9300
FAX: 508/474-9149

SOUTHEASTERN AREA

Duluth, GA
TEL: 770/935-6110
FAX: 770/935-6112

Raleigh, NC
TEL: 919/859-5210
FAX: 919/859-5334

Boca Raton, FL
TEL: 407/241-2364
FAX: 407/241-7990

International

FRANCE

Paris
TEL: 33/1-48-12-2812
FAX: 33/1-48-12-2810

GERMANY

Munich
TEL: 49/81-52-40084
FAX: 49/81-52-40077

HONG KONG

Tsimshatsui
TEL: 852/2376-0801
FAX: 852/2375-1202

ITALY

Milan
TEL: 39/2-3360-5458
FAX: 39/2-3360-5426

JAPAN

Tokyo
TEL: 81/3-3340-9111
FAX: 81/3-3340-9120

KOREA

Seoul
TEL: 82/2-565-8561
FAX: 82/2-565-8565

SINGAPORE

TEL: 65/743-4111
FAX: 65/742-4111

TAIWAN

Taipei
TEL: 886/2-718-4533
FAX: 886/2-718-4526

UNITED KINGDOM

London, England
TEL: 44/1727-872424
FAX: 44/1727-875919

The Company

Headquartered in Fremont, California, Cirrus Logic is a leading manufacturer of advanced integrated circuits for desktop and portable computing, telecommunications, and consumer electronics. The Company applies its system-level expertise in analog and digital design to innovate highly integrated, software-rich solutions.

Cirrus Logic has developed a broad portfolio of products and technologies for applications spanning multimedia, graphics, communications, system logic, mass storage, and data acquisition.

The Cirrus Logic formula combines innovative architectures in silicon with system design expertise. We deliver complete solutions — chips, software, evaluation boards, and manufacturing kits — on-time, to help you win in the marketplace.

Cirrus Logic's manufacturing strategy ensures maximum product quality, availability, and value for our customers.

Talk to our systems and applications specialists; see how you can benefit from a new kind of semiconductor company.

Copyright © 1996 Cirrus Logic Inc. All rights reserved.

Cirrus Logic Inc. has made best efforts to ensure that the information contained in this document is accurate and reliable. However, the information is subject to change without notice. No responsibility is assumed by Cirrus Logic Inc. for the use of this information, nor for infringements of patents or other rights of third parties. This document implies no license under patents, copyrights, or trade secrets. Cirrus, Cirrus Logic, AccuPak, CompactCard, CompactStor, DIVA, FastPath, FasText, FeatureChips, Good Data, Laguna, Laguna 3D, MediaDAC, MotionVideo, SimulSCAN, S/LA, SMASH, SofTarget, TextureJet, TVTap, UXART, VisualMedia, V-Port, WavePort, and WebSet are trademarks of Cirrus Logic Inc., which may be registered in some jurisdictions. Other trademarks in this document belong to their respective companies. CRUS and Cirrus Logic International, Ltd. are trade names of Cirrus Logic Inc.