

HiQV64 High Performance Multimedia Flat Panel/CRT GUI Accelerator

- Highly integrated Flat Panel and CRT GUI Accelerator & Multimedia Engine, Palette/DAC, and Clock Synthesizer
- Hardware Windows Acceleration
 - 64-bit Graphics Engine
 - System-to-Screen and Screen-to-Screen BitBLT
 - 3-Operand Raster-Ops
 - 8/16/24 Color Expansion
 - Transparent BLT
 - Optimized for Windows™ BitBLT format
- PCI Bus with Burst Mode capability and BIOS ROM support
- Flexible Memory Configurations
 - 64-Bit memory interface
 - Two, four, or eight 256Kx16 DRAMs (1MB, 2MB, or 4MB)
 - One or two 512Kx32 DRAMs (2MB or 4MB)
 - Two 128Kx32 DRAMs (1MB)
 - Four 128Kx16 DRAMs (1MB)
- High Performance:
 - Deep write buffers
 - EDO DRAM Support
 - 40 Mhz or higher @ 3.3V
- Hardware MultiMedia Support
 - Zoom Video port
 - YUV input from the system bus or video port
 - YUV-RGB Conversion
 - Capture / Scaling
 - Zoom up to 8x
 - Interpolation
 - Double Buffered Video
- Display centering and stretching features for optimal fit of VGA graphics and text on 800x600 and 1024x768 panels
- Simultaneous Hardware Cursor and Pop-up Window
 - 64x64 pixels by 4 colors
 - 128x128 pixels by 2 colors
- Game Acceleration
 - Source Transparent BLT
 - Destination Transparent BLT
 - Double buffer support for YUV and 15/16Bpp Overlay Engine
 - Instant Full Screen Page Flip
 - Read back of CRT Scanline counters
- Optimized for High-Performance Flat Panel Display at 3.3V
 - 640x480 x 24bpp
 - 800x600 x 24bpp
 - 1024x768 x 16bpp
- CRT Support
 - 80 Mhz @ 3.3V
 - 110 Mhz @ 5.0V
- Direct interface to Monochrome and Color, Single Drive (SS) and Dual Drive (DD), STN & TFT panels
- Flexible On-chip Activity Timer facilitates ordered shut-down of the display system
- Advanced Power Management feature minimizes power usage in:
 - Normal operation
 - Standby (Sleep) modes
 - Panel-Off Power-Saving Mode
- VESAS standards supported
 - VAFC Ports to display "Live" Video
 - DPMS for CRT power-down (required for support of EPA Energy-Star program)
 - DDC for CRT Plug-Play & Display Control
- Composite NTSC / PAL Support
- Power Sequencing control outputs regulate application of bias voltage, +5V to the panel and +12V to the inverter for backlight operation
- Mixed 3.3V and 5.0V operation
- Fully compatible with IBM® VGA

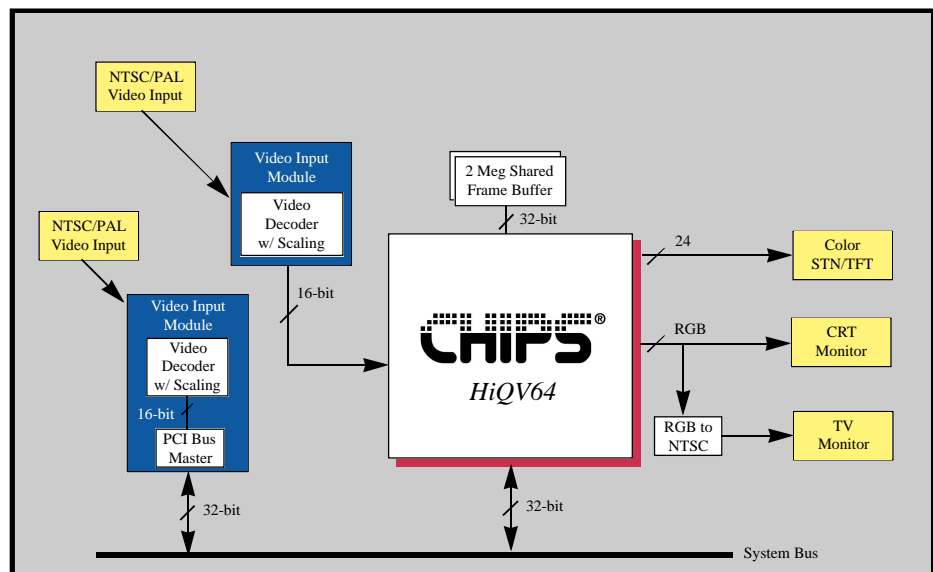

Product Overview

The HiQV64 High Performance Multimedia Flat Panel/CRT GUI Accelerator extends CHIPS' offering of high performance flat panel controllers for full-featured notebooks and sub notebooks.

High Performance

Based on a totally new internal architecture, the HiQV64 controller integrates a powerful 64-bit graphics accelerator engine for Bit Block Transfer (BitBLT), hardware cursor, and other functions intensively used in Graphical User Interfaces (GUIs) such as Microsoft Windows. When combined with CHIPS' advanced linear acceleration driver technology, the HiQV64 controller offers exceptional performance.

Hardware MultiMedia Support

The HiQV64 controller uses independent multimedia capture and display systems on the chip. The capture system places data in display memory and the display system places the data into a window on the screen.

The capture system can receive data from either the system bus or from the ZV enabled video port in either RGB or YUV format. The input data can also be scaled down before storage in display memory (e.g., from any size larger than 320x240 down to 352x248). Capture of input data may also be double-buffered for smoothing and to prevent image tearing.

The display system can independently place either RGB or YUV data from anywhere in display memory into an on-screen window which can be any size and located at any pixel boundary (YUV data is converted to RGB "on-the-fly" on output). The controller uses color keying to support non-rectangular windows. The data can be fractionally zoomed on output up to 8x to fit the on-screen window and can be horizontally and vertically interpolated to scale or zoom. Interlaced and noninterlaced data are supported in both capture and display systems.

Versatile Panel Support

The HiQV64 controller supports a wide variety of monochrome and color Single-Panel, Single-Drive (SS) and Dual-Panel, Dual Drive (DD) standard and high-res passive STN and active matrix TFT/MIM LCD, and EL panels. For monochrome panels, up to 64 gray scales are supported. Up to 4096 different colors can be displayed on passive STN LCDs, and up to 16M colors on 24-bit active matrix LCDs.

The HiQV64 controller offers a variety of programmable features to optimize display quality. Vertical centering and stretching are provided for handling modes with less than 480 lines on 480 line panels. Horizontal and vertical stretching capabilities are also available for both text and graphics modes for optimal display of VGA text and graphics modes on 800x600 and 1024x768 panels.

Three selectable color-to-gray scale reduction techniques and SMARTMAP™ are available to improve the ability to view color applications on monochrome panels. CHIPS' polynomial FRC algorithm reduces panel flicker on a wider range of panel types with a single setting for a particular panel type.

Low Power Consumption

The HiQV64 controller uses a variety of advanced power management features to reduce power consumption of the display subsystem and extend battery life. Although optimized for 3.3V operation, the HiQV64 controller's internal logic, memory interface, bus interface, and panel interfaces can be independently configured to operate at either 3.3V or 5.0V.

Software Compatibility / Flexibility

The HiQV64 controller is fully compatible with VGA at the register and BIOS levels. CHIPS and third-party vendors supply fully VGA-compatible BIOS, end-user utilities and drivers for common application programs such as Microsoft Windows™ and OS/2.

Ordering Information

The HiQV64 controller is available in a 256 ball BGA package. Contact your CHIPS representative to order part number B65554.

Copyright 1995-96, Chips and Technologies, Inc. ALL RIGHTS RESERVED. CHIPS Logo and SMARTMAPa registered trademarks of Chips and Technologies, Inc. HiQV64 and HiQVideo are trademarks of Chips and Technologies, Inc. All other trademarks are the property of their respective holders.

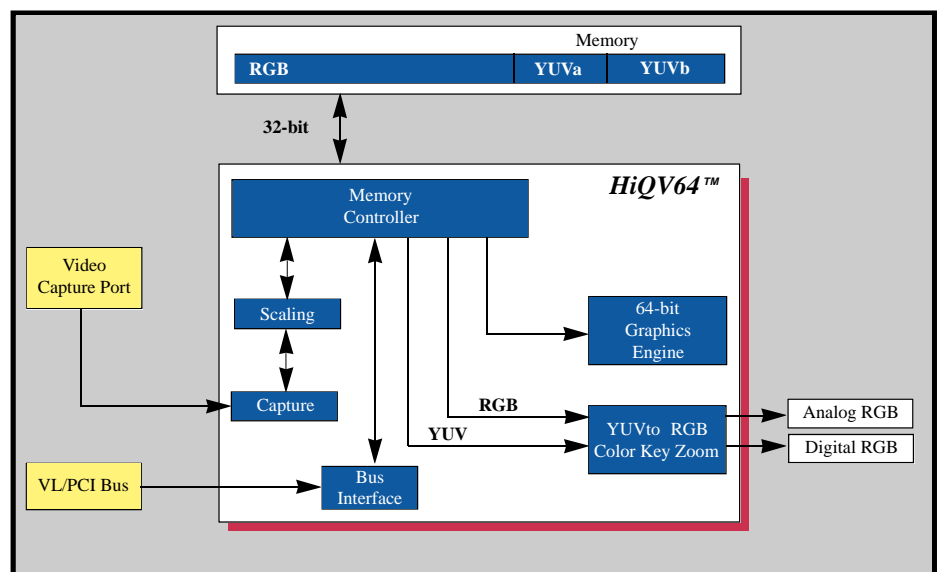

Publication No: PO54.2
Stock No.: 067054-002
Revision: 0.3
Date: 9/12/96