



Intel® 64 and IA-32 Architectures Optimization Reference Manual

Order Number: 248966-046
January 2023

Notices & Disclaimers

Intel technologies may require enabled hardware, software or service activation.

No product or component can be absolutely secure.

Your costs and results may vary.

You may not use or facilitate the use of this document in connection with any infringement or other legal analysis concerning Intel products described herein. You agree to grant Intel a non-exclusive, royalty-free license to any patent claim thereafter drafted which includes subject matter disclosed herein.

All product plans and roadmaps are subject to change without notice.

The products described may contain design defects or errors known as errata which may cause the product to deviate from published specifications. Current characterized errata are available on request.

Intel disclaims all express and implied warranties, including without limitation, the implied warranties of merchantability, fitness for a particular purpose, and non-infringement, as well as any warranty arising from course of performance, course of dealing, or usage in trade.

Code names are used by Intel to identify products, technologies, or services that are in development and not publicly available. These are not "commercial" names and not intended to function as trademarks.

No license (express or implied, by estoppel or otherwise) to any intellectual property rights is granted by this document, with the sole exception that a) you may publish an unmodified copy and b) code included in this document is licensed subject to the Zero-Clause BSD open source license (0BSD), <https://opensource.org/licenses/0BSD>. You may create software implementations based on this document and in compliance with the foregoing that are intended to execute on the Intel product(s) referenced in this document. No rights are granted to create modifications or derivatives of this document.

© Intel Corporation. Intel, the Intel logo, and other Intel marks are trademarks of Intel Corporation or its subsidiaries. Other names and brands may be claimed as the property of others.

CHAPTER 1 INTRODUCTION

1.1	TUNING YOUR APPLICATION	1-1
1.2	ABOUT THIS MANUAL	1-1
1.3	RELATED INFORMATION	1-4

CHAPTER 2 INTEL® 64 AND IA-32 PROCESSOR ARCHITECTURES

2.1	SAPPHIRE RAPIDS ARCHITECTURE	2-1
2.1.1	Intel® 4th generation Intel® Xeon® Scalable Family of Processors	2-1
2.2	ALDER LAKE PERFORMANCE HYBRID ARCHITECTURE	2-2
2.2.1	12th Generation Intel® Core™ Processors Supporting Performance Hybrid Architecture	2-2
2.2.2	Hybrid Scheduling	2-2
2.2.2.1	Intel® Thread Director	2-2
2.2.2.2	Scheduling with Intel Hyper-Threading Technology Enabled on Processors Supporting x86 Hybrid Architecture	2-6
2.2.2.3	Scheduling with a Multi-E-Core Module	2-6
2.2.2.4	Scheduling Background Threads on x86 Hybrid Architecture	2-6
2.2.3	Recommendations for Application Developers	2-6
2.3	GOLDEN COVE MICROARCHITECTURE	2-7
2.3.1	Golden Cove Microarchitecture Overview	2-8
2.3.1.1	The Front End	2-9
2.3.1.2	The Out-of-Order and Execution Engines	2-9
2.3.1.3	Cache Subsystem and Memory Subsystem	2-12
2.3.1.4	Avoiding Destination False Dependency	2-12
2.4	ICE LAKE CLIENT MICROARCHITECTURE	2-14
2.4.1	Ice Lake Client Microarchitecture Overview	2-14
2.4.1.1	The Front End	2-15
2.4.1.2	The Out of Order and Execution Engines	2-15
2.4.1.3	Cache and Memory Subsystem	2-17
	Paired Stores	2-18
2.4.1.4	New Instructions	2-19
2.4.1.5	Ice Lake Client Microarchitecture Power Management	2-20
2.5	SKYLAKE SERVER MICROARCHITECTURE	2-21
2.5.1	Skylake Server Microarchitecture Cache	2-22
2.5.1.1	Larger Mid-Level Cache	2-22
2.5.1.2	Non-Inclusive Last Level Cache	2-22
2.5.1.3	Skylake Server Microarchitecture Cache Recommendations	2-23
2.5.2	Non-Temporal Stores on Skylake Server Microarchitecture	2-24
2.5.3	Skylake Server Power Management	2-25
2.6	SKYLAKE CLIENT MICROARCHITECTURE	2-28
2.6.1	The Front End	2-29
2.6.2	The Out-of-Order Execution Engine	2-29
2.6.3	Cache and Memory Subsystem	2-31
2.6.4	Pause Latency in Skylake Client Microarchitecture	2-32
2.7	INTEL® HYPER-THREADING TECHNOLOGY	2-34
2.7.1	Processor Resources and HT Technology	2-35
2.7.1.1	Replicated Resources	2-36
2.7.1.2	Partitioned Resources	2-36
2.7.1.3	Shared Resources	2-36
2.7.2	Microarchitecture Pipeline and HT Technology	2-36
2.7.3	Execution Core	2-37
2.7.4	Retirement	2-37
2.8	SIMD TECHNOLOGY	2-37

2.9	SUMMARY OF SIMD TECHNOLOGIES AND APPLICATION LEVEL EXTENSIONS	2-39
2.9.1	MMX™ Technology	2-39
2.9.2	Streaming SIMD Extensions	2-39
2.9.3	Streaming SIMD Extensions 2.....	2-39
2.9.4	Streaming SIMD Extensions 3.....	2-40
2.9.5	Supplemental Streaming SIMD Extensions 3	2-40
2.9.6	SSE4.1	2-40
2.9.7	SSE4.2	2-41
2.9.8	AESNI and PCLMULQDQ	2-41
2.9.9	Intel® Advanced Vector Extensions	2-41
2.9.10	Half-Precision Floating-Point Conversion (F16C).....	2-42
2.9.11	RDRAND	2-42
2.9.12	Fused-Multiply-ADD (FMA) Extensions	2-42
2.9.13	Intel AVX2	2-42
2.9.14	General-Purpose Bit-Processing Instructions	2-42
2.9.15	Intel® Transactional Synchronization Extensions.....	2-42
2.9.16	RDSEED	2-43
2.9.17	ADCX and ADOX Instructions	2-43

CHAPTER 3

GENERAL OPTIMIZATION GUIDELINES

3.1	PERFORMANCE TOOLS	3-1
3.1.1	Intel® C++ and Fortran Compilers	3-1
3.1.2	General Compiler Recommendations	3-2
3.1.3	VTune™ Performance Analyzer	3-2
3.2	PROCESSOR PERSPECTIVES	3-2
3.2.1	CPUID Dispatch Strategy and Compatible Code Strategy	3-2
3.2.2	Transparent Cache-Parameter Strategy.....	3-3
3.2.3	Threading Strategy and Hardware Multithreading Support	3-3
3.3	CODING RULES, SUGGESTIONS AND TUNING HINTS	3-3
3.4	OPTIMIZING THE FRONT END.....	3-4
3.4.1	Branch Prediction Optimization	3-4
3.4.1.1	Eliminating Branches.....	3-4
3.4.1.2	Static Prediction	3-6
3.4.1.3	Inlining, Calls and Returns	3-7
3.4.1.4	Code Alignment.....	3-8
3.4.1.5	Branch Type Selection	3-8
3.4.1.6	Loop Unrolling	3-10
3.4.2	Fetch and Decode Optimization.....	3-11
3.4.2.1	Optimizing for Micro-fusion.....	3-11
3.4.2.2	Optimizing for Macrofusion.....	3-12
3.4.2.3	Length-Changing Prefixes (LCP)	3-16
3.4.2.4	Optimizing the Loop Stream Detector (LSD)	3-17
3.4.2.5	Optimization for Decoded ICache	3-18
3.4.2.6	Other Decoding Guidelines	3-19
3.5	OPTIMIZING THE EXECUTION CORE	3-19
3.5.1	Instruction Selection	3-20
3.5.1.1	Integer Divide	3-20
3.5.1.2	Using LEA	3-21
3.5.1.3	ADC and SBB in Sandy Bridge Microarchitecture	3-22
3.5.1.4	Bitwise Rotation.....	3-23
3.5.1.5	Variable Bit Count Rotation and Shift	3-24
3.5.1.6	Address Calculations	3-24
3.5.1.7	Clearing Registers and Dependency Breaking Idioms	3-25
3.5.1.8	Compares	3-26
3.5.1.9	Using NOPs.....	3-27
3.5.1.10	Mixing SIMD Data Types.....	3-28
3.5.1.11	Spill Scheduling	3-28
3.5.1.12	Zero-Latency MOV Instructions.....	3-28
3.5.2	Avoiding Stalls in Execution Core	3-30
3.5.2.1	Writeback Bus Conflicts	3-30
3.5.2.2	Bypass between Execution Domains.....	3-31
3.5.2.3	Partial Register Stalls	3-31
3.5.2.4	Partial XMM Register Stalls.....	3-32

3.5.2.5	Partial Flag Register Stalls	3-33
3.5.2.6	Floating-Point/SIMD Operands	3-34
3.5.3	Vectorization	3-34
3.5.4	Optimization of Partially Vectorizable Code	3-35
3.5.4.1	Alternate Packing Techniques	3-37
3.5.4.2	Simplifying Result Passing	3-37
3.5.4.3	Stack Optimization	3-38
3.5.4.4	Tuning Considerations	3-38
3.6	OPTIMIZING MEMORY ACCESSES	3-40
3.6.1	Load and Store Execution Bandwidth	3-40
3.6.1.1	Making Use of Load Bandwidth in Sandy Bridge Microarchitecture	3-40
3.6.1.2	L1D Cache Latency in Sandy Bridge Microarchitecture	3-41
3.6.1.3	Handling L1D Cache Bank Conflict	3-42
3.6.2	Minimize Register Spills	3-43
3.6.3	Enhance Speculative Execution and Memory Disambiguation	3-44
3.6.4	Store Forwarding	3-45
3.6.4.1	Store-to-Load-Forwarding Restriction on Size and Alignment	3-46
3.6.4.2	Store-forwarding Restriction on Data Availability	3-48
3.6.5	Data Layout Optimizations	3-49
3.6.6	Stack Alignment	3-51
3.6.7	Capacity Limits and Aliasing in Caches	3-52
3.6.8	Mixing Code and Data	3-52
3.6.8.1	Self-modifying Code	3-52
3.6.8.2	Position Independent Code	3-53
3.6.9	Write Combining	3-53
3.6.10	Locality Enhancement	3-54
3.6.11	Non-Temporal Store Bus Traffic	3-55
3.7	PREFETCHING	3-56
3.7.1	Hardware Instruction Fetching and Software Prefetching	3-56
3.7.2	Hardware Prefetching for First-Level Data Cache	3-56
3.7.3	Hardware Prefetching for Second-Level Cache	3-58
3.7.4	Cacheability Instructions	3-59
3.7.5	REP Prefix and Data Movement	3-59
3.7.6	Enhanced REP MOVSB and STOSB Operation	3-61
3.7.6.1	Fast Short REP MOVSB	3-61
3.7.6.2	Memcpy Considerations	3-61
3.7.6.3	Memmove Considerations	3-63
3.7.6.4	Memset Considerations	3-63
3.8	REP STRING OPERATIONS	3-63
3.8.1	Fast Zero Length REP MOVSB	3-64
3.8.2	Fast Short REP STOSB	3-64
3.8.3	Fast Short REP CMPSB and SCASB	3-64
3.9	FLOATING-POINT CONSIDERATIONS	3-64
3.9.1	Guidelines for Optimizing Floating-point Code	3-64
3.9.2	Floating-point Modes and Exceptions	3-65
3.9.2.1	Floating-point Exceptions	3-65
3.9.2.2	Dealing with floating-point exceptions in x87 FPU code	3-66
3.9.2.3	Floating-point Exceptions in SSE/SSE2/SSE3 Code	3-66
3.9.3	Floating-point Modes	3-66
3.9.3.1	Rounding Mode	3-67
3.9.3.2	Precision	3-68
3.9.4	x87 vs. Scalar SIMD Floating-point Trade-offs	3-69
3.9.4.1	Scalar SSE/SSE2	3-69
3.9.4.2	Transcendental Functions	3-69
3.10	MAXIMIZING PCIe PERFORMANCE	3-70
3.10.1	Optimizing PCIe Performance for Accesses Toward Coherent Memory and Toward MMIO Regions (P2P)	3-70
3.11	SCALABILITY WITH CONTENTED LINE ACCESS IN INTEL® 4TH GENERATION INTEL® XEON® SCALABLE PROCESSORS	3-71
3.11.1	Why it Happens	3-71
3.11.2	How to Detect it	3-71
3.11.3	How to Fix it	3-72
3.11.4	Case Study: SysBench/MariaDB Metric CHA % Cycles Fast Asserted	3-73
3.11.5	Instruction Sequence Slowdowns	3-74
3.11.5.1	Why it Happens	3-74

3.11.5.2	How to Detect it	3-74
3.11.5.3	How to Fix it	3-74
3.11.6	Misprediction for Branches >2GB	3-75
3.11.6.1	Why it Happens	3-75
3.11.6.2	How to Detect it	3-75
3.11.6.3	How to Fix it	3-76
3.12	OPTIMIZING COMMUNICATION WITH PCI DEVICES ON INTEL® 4TH GENERATION INTEL® XEON® SCALABLE PROCESSORS	3-77
3.12.1	Signaling Devices with Direct Move	3-77
3.12.1.1	MOVDIR64B - Additional considerations	3-77
3.12.1.2	Streaming Data	3-78
3.13	SYNCHRONIZATION	3-78
3.13.1	User-Level Monitor, User-Level MWAIT, and TPAUSE	3-78
3.13.1.1	Checking for User-Level Monitor, MWAIT, and TPAUSE support	3-78
3.13.1.2	User-Level Monitor, User-Level MWAIT, and TPAUSE Operations	3-78
3.13.1.3	Recommended usage	3-79

CHAPTER 4 INTEL ATOM® PROCESSOR ARCHITECTURES

4.1	GRACEMONT MICROARCHITECTURE	4-1
4.1.1	Gracemont Microarchitecture Overview	4-1
4.1.2	Predict and Fetch	4-2
4.1.3	Dynamic Load Balancing	4-4
4.1.4	Decode and the On-Demand Instruction Length Decoder	4-4
4.1.5	Allocation and Retirement	4-5
4.1.6	The Out-of-Order and Execution Engines	4-5
4.1.7	Cache and Memory Subsystem	4-7
4.1.8	Intel® AVX and Intel® AVX2 Instruction Support	4-8
4.1.8.1	256-bit Permute Operations	4-8
4.1.8.2	256-bit Broadcast with 128-bit Memory Operand	4-8
4.1.8.3	256-bit Insertion, Up-Conversion Instructions with 128-bit Memory Operand	4-8
4.1.8.4	256-bit Variable Blend Instructions	4-9
4.1.8.5	256-bit Vector TEST Instructions	4-9
4.1.8.6	GATHER Instructions	4-9
4.1.8.7	Masked Load and Store Instructions	4-9
4.1.8.8	ADX Instructions	4-9
4.1.8.9	BMI1, BMI2, and LZCNT Instructions	4-10
4.2	TREMONT MICROARCHITECTURE	4-10
4.2.1	Tremont Microarchitecture Overview	4-10
4.2.2	The Front End	4-11
4.2.3	The Out of Order and Execution Engines	4-12
4.2.4	Cache and Memory Subsystem	4-13
4.2.5	New Instructions	4-13
4.2.6	Tremont Microarchitecture Power Management	4-14

CHAPTER 5 CODING FOR SIMD ARCHITECTURES

5.1	CHECKING FOR PROCESSOR SUPPORT OF SIMD TECHNOLOGIES	5-1
5.1.1	Checking for MMX Technology Support	5-2
5.1.2	Checking for Streaming SIMD Extensions Support	5-2
5.1.3	Checking for Streaming SIMD Extensions 2 Support	5-2
5.1.4	Checking for Streaming SIMD Extensions 3 Support	5-3
5.1.5	Checking for Supplemental Streaming SIMD Extensions 3 Support	5-3
5.1.6	Checking for SSE4.1 Support	5-4
5.1.7	Checking for SSE4.2 Support	5-4
5.1.8	DetectiON of PCLMULQDQ and AESNI Instructions	5-4
5.1.9	Detection of AVX Instructions	5-5
5.1.10	Detection of VEX-Encoded AES and VPCLMULQDQ	5-7
5.1.11	Detection of F16C Instructions	5-7
5.1.12	Detection of FMA	5-8
5.1.13	Detection of AVX2	5-9
5.2	CONSIDERATIONS FOR CODE CONVERSION TO SIMD PROGRAMMING	5-10

5.2.1	Identifying Hot Spots	5-12
5.2.2	Determine If Code Benefits by Conversion to SIMD Execution	5-12
5.3	CODING TECHNIQUES	5-12
5.3.1	Coding Methodologies	5-13
5.3.1.1	Assembly	5-14
5.3.1.2	Intrinsics	5-14
5.3.1.3	Classes	5-15
5.3.1.4	Automatic Vectorization	5-16
5.4	STACK AND DATA ALIGNMENT	5-17
5.4.1	Alignment and Contiguity of Data Access Patterns	5-17
5.4.1.1	Using Padding to Align Data	5-17
5.4.1.2	Using Arrays to Make Data Contiguous	5-17
5.4.2	Stack Alignment For 128-bit SIMD Technologies	5-18
5.4.3	Data Alignment for MMX Technology	5-18
5.4.4	Data Alignment for 128-bit data	5-19
5.4.4.1	Compiler-Supported Alignment	5-19
5.5	IMPROVING MEMORY UTILIZATION	5-20
5.5.1	Data Structure Layout	5-20
5.5.2	Strip-Mining	5-23
5.5.3	Loop Blocking	5-24
5.6	INSTRUCTION SELECTION	5-26
5.7	TUNING THE FINAL APPLICATION	5-27

CHAPTER 6 OPTIMIZING FOR SIMD INTEGER APPLICATIONS

6.1	GENERAL RULES ON SIMD INTEGER CODE	6-1
6.2	USING SIMD INTEGER WITH X87 FLOATING-POINT	6-2
6.2.1	Using the EMMS Instruction	6-2
6.2.2	Guidelines for Using EMMS Instruction	6-2
6.3	DATA ALIGNMENT	6-3
6.4	DATA MOVEMENT CODING TECHNIQUES	6-5
6.4.1	Unsigned Unpack	6-5
6.4.2	Signed Unpack	6-5
6.4.3	Interleaved Pack with Saturation	6-6
6.4.4	Interleaved Pack without Saturation	6-7
6.4.5	Non-Interleaved Unpack	6-8
6.4.6	Extract Data Element	6-9
6.4.7	Insert Data Element	6-10
6.4.8	Non-Unit Stride Data Movement	6-11
6.4.9	Move Byte Mask to Integer	6-12
6.4.10	Packed Shuffle Word for 64-bit Registers	6-12
6.4.11	Packed Shuffle Word for 128-bit Registers	6-13
6.4.12	Shuffle Bytes	6-13
6.4.13	Conditional Data Movement	6-14
6.4.14	Unpacking/interleaving 64-bit Data in 128-bit Registers	6-14
6.4.15	Data Movement	6-14
6.4.16	Conversion Instructions	6-14
6.5	GENERATING CONSTANTS	6-14
6.6	BUILDING BLOCKS	6-15
6.6.1	Absolute Difference of Unsigned Numbers	6-15
6.6.2	Absolute Difference of Signed Numbers	6-16
6.6.3	Absolute Value	6-16
6.6.4	Pixel Format Conversion	6-17
6.6.5	Endian Conversion	6-18
6.6.6	Clipping to an Arbitrary Range [High, Low]	6-19
6.6.6.1	Highly Efficient Clipping	6-19
6.6.6.2	Clipping to an Arbitrary Unsigned Range [High, Low]	6-21
6.6.7	Packed Max/Min of Byte, Word and Dword	6-21
6.6.8	Packed Multiply Integers	6-21
6.6.9	Packed Sum of Absolute Differences	6-22
6.6.10	MPSADBw and PHMINPOSUw	6-22
6.6.11	Packed Average (Byte/Word)	6-22
6.6.12	Complex Multiply by a Constant	6-22
6.6.13	Packed 64-bit Add/Subtract	6-23

6.6.14	128-bit Shifts	6-23
6.6.15	PTEST and Conditional Branch	6-23
6.6.16	Vectorization of Heterogeneous Computations across Loop Iterations	6-24
6.6.17	Vectorization of Control Flows in Nested Loops	6-25
6.7	MEMORY OPTIMIZATIONS	6-27
6.7.1	Partial Memory Accesses	6-28
6.7.2	Increasing Bandwidth of Memory Fills and Video Fills	6-29
6.7.2.1	Increasing Memory Bandwidth Using the MOVDQ Instruction	6-29
6.7.2.2	Increasing Memory Bandwidth by Loading and Storing to and from the Same DRAM	6-29
6.7.2.3	Increasing UC and WC Store Bandwidth by Using Aligned Stores	6-30
6.7.3	Reverse Memory Copy	6-30
6.8	CONVERTING FROM 64-BIT TO 128-BIT SIMD INTEGERS	6-33
6.8.1	SIMD Optimizations and Microarchitectures	6-33
6.8.1.1	Packed SSE2 Integer versus MMX Instructions	6-33
6.8.1.2	Work-around for False Dependency Issue	6-34
6.9	TUNING PARTIALLY VECTORIZABLE CODE	6-34
6.10	PARALLEL MODE AES ENCRYPTION AND DECRYPTION	6-37
6.10.1	AES Counter Mode of Operation	6-37
6.10.2	AES Key Expansion Alternative	6-45
6.10.3	Enhancement in Haswell Microarchitecture	6-47
6.10.3.1	AES and Multi-Buffer Cryptographic Throughput	6-47
6.10.3.2	PCLMULQDQ Improvement	6-47
6.11	LIGHT-WEIGHT DECOMPRESSION AND DATABASE PROCESSING	6-47
6.11.1	Reduced Dynamic Range Datasets	6-48
6.11.2	Compression and Decompression Using SIMD Instructions	6-48

CHAPTER 7

OPTIMIZING FOR SIMD FLOATING-POINT APPLICATIONS

7.1	GENERAL RULES FOR SIMD FLOATING-POINT CODE	7-1
7.2	PLANNING CONSIDERATIONS	7-1
7.3	USING SIMD FLOATING-POINT WITH X87 FLOATING-POINT	7-2
7.4	SCALAR FLOATING-POINT CODE	7-2
7.5	DATA ALIGNMENT	7-2
7.5.1	Data Arrangement	7-2
7.5.1.1	Vertical versus Horizontal Computation	7-3
7.5.1.2	Data Swizzling	7-5
7.5.1.3	Data Deswizzling	7-7
7.5.1.4	Horizontal ADD Using SSE	7-8
7.5.2	Use of CVTTSS2PI/CVTTSS2SI Instructions	7-10
7.5.3	Flush-to-Zero and Denormals-are-Zero Modes	7-10
7.6	SIMD OPTIMIZATIONS AND MICROARCHITECTURES	7-11
7.6.1	SIMD Floating-point Programming Using SSE3	7-11
7.6.1.1	SSE3 and Complex Arithmetics	7-12
7.6.1.2	Packed Floating-Point Performance in Intel Core Duo Processor	7-14
7.6.2	Dot Product and Horizontal SIMD Instructions	7-14
7.6.3	Vector Normalization	7-16
7.6.4	Using Horizontal SIMD Instruction Sets and Data Layout	7-18
7.6.4.1	SOA and Vector Matrix Multiplication	7-20

CHAPTER 8

INT8 DEEP LEARNING INFERENCE

8.1	INTRODUCING INT8 AS DATA TYPE FOR DEEP LEARNING INFERENCE	8-1
8.2	INTRODUCING INTEL® DL BOOST	8-1
8.2.1	Multiply and Add Unsigned and Signed Bytes (VPDPBUSD Instruction)	8-2
8.2.2	Multiply and Add Signed Word Integers (VPDPWSSD Instruction)	8-4
8.3	GENERAL OPTIMIZATIONS	8-4
8.3.1	Memory Layout	8-4
8.3.2	Quantization	8-4
8.3.2.1	Quantization of Weights	8-5
8.3.2.2	Quantization of Activations	8-5
8.3.2.3	Quantizing Negative Activations	8-6
8.3.3	Multicore Considerations	8-6

8.3.3.1	Large Batch (Throughput Workload)	8-6
8.3.3.2	Small Batch (Throughput at Latency Workload)	8-6
8.3.3.3	NUMA	8-6
8.4	CNNS	8-7
8.4.1	Convolutional Layers	8-7
8.4.1.1	Direct Convolution	8-7
	Memory Layout	8-7
	Matrix Multiplication	8-9
	Blocking	8-9
	Direct Convolution Example	8-10
8.4.1.2	Convolutional Layers with Low OFM Count	8-13
8.4.2	Post Convolution	8-15
8.4.2.1	Fused Quantization/Dequantization	8-15
8.4.2.2	ReLU	8-16
8.4.2.3	EltWise	8-17
8.4.2.4	Pooling	8-17
8.4.2.5	Pixel Shuffler	8-19
8.5	LSTM NETWORKS	8-21
8.5.1	Fused LSTM Embedding	8-21
8.5.2	Fused post GEMM	8-21
8.5.3	Dynamic Batch Size	8-24
8.5.4	NMT Example: Beam Search Decoder Get Top K	8-24

CHAPTER 9 OPTIMIZING CACHE USAGE

9.1	GENERAL PREFETCH CODING GUIDELINES	9-1
9.2	PREFETCH AND CACHEABILITY INSTRUCTIONS	9-2
9.3	PREFETCH	9-2
9.3.1	Software Data Prefetch	9-2
9.3.2	Prefetch Instructions	9-3
9.3.3	Prefetch and Load Instructions	9-4
9.4	CACHEABILITY CONTROL	9-5
9.4.1	The Non-temporal Store Instructions	9-5
9.4.1.1	Fencing	9-5
9.4.1.2	Streaming Non-temporal Stores	9-6
9.4.1.3	Memory Type and Non-temporal Stores	9-6
9.4.1.4	Write-Combining	9-6
9.4.2	Streaming Store Usage Models	9-7
9.4.2.1	Coherent Requests	9-7
9.4.2.2	Non-coherent requests	9-7
9.4.3	Streaming Store Instruction Descriptions	9-7
9.4.4	The Streaming Load Instruction	9-8
9.4.5	FENCE Instructions	9-8
9.4.5.1	SFENCE Instruction	9-8
9.4.5.2	LFENCE Instruction	9-8
9.4.5.3	MFENCE Instruction	9-9
9.4.6	CLFLUSH Instruction	9-9
9.4.7	CLFLUSHOPT Instruction	9-10
9.5	MEMORY OPTIMIZATION USING PREFETCH	9-12
9.5.1	Software-Controlled Prefetch	9-12
9.5.2	Hardware Prefetch	9-12
9.5.3	Example of Effective Latency Reduction with Hardware Prefetch	9-13
9.5.4	Example of Latency Hiding with S/W Prefetch Instruction	9-14
9.5.5	Software Prefetching Usage Checklist	9-15
9.5.6	Software Prefetch Scheduling Distance	9-16
9.5.7	Software Prefetch Concatenation	9-16
9.5.8	Minimize Number of Software Prefetches	9-17
9.5.9	Mix Software Prefetch with Computation Instructions	9-19
9.5.10	Software Prefetch and Cache Blocking Techniques	9-19
9.5.11	Hardware Prefetching and Cache Blocking Techniques	9-23
9.5.12	Single-pass versus Multi-pass Execution	9-24
9.6	MEMORY OPTIMIZATION USING NON-TEMPORAL STORES	9-25
9.6.1	Non-temporal Stores and Software Write-Combining	9-25

9.6.2	Cache Management	9-26
9.6.2.1	Video Encoder	9-26
9.6.2.2	Video Decoder	9-26
9.6.2.3	Conclusions from Video Encoder and Decoder Implementation	9-27
9.6.2.4	Optimizing Memory Copy Routines	9-27
9.6.2.5	Using the 8-byte Streaming Stores and Software Prefetch	9-28
9.6.2.6	Using 16-byte Streaming Stores and Hardware Prefetch	9-29
9.6.2.7	Performance Comparisons of Memory Copy Routines	9-30
9.6.3	Deterministic Cache Parameters	9-30
9.6.3.1	Cache Sharing Using Deterministic Cache Parameters	9-31
9.6.3.2	Cache Sharing in Single-Core or Multicore	9-32
9.6.3.3	Determine Prefetch Stride	9-32

CHAPTER 10 SUB-NUMA CLUSTERING

10.1	SUB-NUMA CLUSTERING	10-1
10.2	COMPARISON WITH CLUSTER-ON-DIE	10-1
10.3	SNC USAGE	10-2
10.3.1	How to Check NUMA Configuration	10-2
10.3.2	MPI Optimizations for SNC	10-7
10.3.3	SNC Performance Comparison	10-8

CHAPTER 11 MULTICORE AND HYPER-THREADING TECHNOLOGY

11.1	PERFORMANCE AND USAGE MODELS	11-1
11.1.1	Multithreading	11-1
11.1.2	Multitasking Environment	11-2
11.2	PROGRAMMING MODELS AND MULTITHREADING	11-3
11.2.1	Parallel Programming Models	11-4
11.2.1.1	Domain Decomposition	11-4
11.2.2	Functional Decomposition	11-4
11.2.3	Specialized Programming Models	11-4
11.2.3.1	Producer-Consumer Threading Models	11-5
11.2.4	Tools for Creating Multithreaded Applications	11-7
11.2.4.1	Programming with OpenMP Directives	11-8
11.2.4.2	Automatic Parallelization of Code	11-8
11.2.4.3	Supporting Development Tools	11-8
11.3	OPTIMIZATION GUIDELINES	11-8
11.3.1	Key Practices of Thread Synchronization	11-8
11.3.2	Key Practices of System Bus Optimization	11-9
11.3.3	Key Practices of Memory Optimization	11-9
11.3.4	Key Practices of Execution Resource Optimization	11-9
11.3.5	Generality and Performance Impact	11-10
11.4	THREAD SYNCHRONIZATION	11-10
11.4.1	Choice of Synchronization Primitives	11-10
11.4.2	Synchronization for Short Periods	11-11
11.4.3	Optimization with Spin-Locks	11-13
11.4.4	Synchronization for Longer Periods	11-13
11.4.4.1	Avoid Coding Pitfalls in Thread Synchronization	11-14
11.4.5	Prevent Sharing of Modified Data and False-Sharing	11-14
11.4.6	Placement of Shared Synchronization Variable	11-15
11.5	SYSTEM BUS OPTIMIZATION	11-16
11.5.1	Conserve Bus Bandwidth	11-17
11.5.2	Understand the Bus and Cache Interactions	11-17
11.5.3	Avoid Excessive Software Prefetches	11-17
11.5.4	Improve Effective Latency of Cache Misses	11-18
11.5.5	Use Full Write Transactions to Achieve Higher Data Rate	11-18
11.6	MEMORY OPTIMIZATION	11-19
11.6.1	Cache Blocking Technique	11-19
11.6.2	Shared-Memory Optimization	11-19
11.6.2.1	Minimize Sharing of Data between Physical Processors	11-19
11.6.2.2	Batched Producer-Consumer Model	11-20

11.6.3	Eliminate 64-KByte Aliased Data Accesses	11-21
11.7	FRONT END OPTIMIZATION	11-21
11.7.1	Avoid Excessive Loop Unrolling	11-21
11.8	AFFINITIES AND MANAGING SHARED PLATFORM RESOURCES	11-22
11.8.1	Topology Enumeration of Shared Resources	11-23
11.8.2	Non-Uniform Memory Access	11-23
11.9	OPTIMIZATION OF OTHER SHARED RESOURCES	11-25
11.9.1	Expanded Opportunity for HT Optimization	11-25

CHAPTER 12

INTEL® OPTANE™ DC PERSISTENT MEMORY

12.1	MEMORY MODE AND APP-DIRECT MODE	12-1
12.1.1	Memory Mode	12-1
12.1.2	App Direct Mode	12-1
12.1.3	Selecting a Mode	12-2
12.2	DEVICE CHARACTERISTICS OF INTEL® OPTANE™ DC PERSISTENT MEMORY MODULE ..	12-3
12.2.1	Intel® Optane™ DC Persistent Memory Module Latency	12-4
12.2.2	Read vs. Write Bandwidth	12-4
12.2.3	Number of Threads for Optimal Bandwidth	12-5
12.3	PLATFORM IMPLICATIONS OF HANDLING A SECOND TYPE OF MEMORY	12-8
12.3.1	Multi-Processor Cache Coherence	12-8
12.3.2	Shared Queues in the Memory Hierarchy	12-9
12.4	IMPLEMENTING PERSISTENCE FOR MEMORY	12-9
12.5	POWER CONSUMPTION	12-10
12.5.1	Read-Write Equivalence	12-10
12.5.2	Spatial and Temporal Locality	12-12

CHAPTER 13

64-BIT MODE CODING GUIDELINES

13.1	INTRODUCTION	13-1
13.2	CODING RULES AFFECTING 64-BIT MODE	13-1
13.2.1	Use Legacy 32-Bit Instructions When Data Size Is 32 Bits	13-1
13.2.2	Use Extra Registers to Reduce Register Pressure	13-1
13.2.3	Effective Use of 64-Bit by 64-Bit Multiplication	13-2
13.2.4	Replace 128-bit Integer Division with 128-bit Multiplication	13-2
13.2.5	Sign Extension to Full 64-Bits	13-4
13.3	ALTERNATE CODING RULES FOR 64-BIT MODE	13-5
13.3.1	Use 64-Bit Registers Instead of Two 32-Bit Registers for 64-Bit Arithmetic Result	13-5
13.3.2	Using Software Prefetch	13-6

CHAPTER 14

SSE4.2 AND SIMD PROGRAMMING FOR TEXT- PROCESSING/LEXING/PARSING

14.1	SSE4.2 STRING AND TEXT INSTRUCTIONS	14-1
14.1.1	CRC32	14-4
14.2	USING SSE4.2 STRING AND TEXT INSTRUCTIONS	14-5
14.2.1	Unaligned Memory Access and Buffer Size Management	14-5
14.2.2	Unaligned Memory Access and String Library	14-6
14.3	SSE4.2 APPLICATION CODING GUIDELINE AND EXAMPLES	14-6
14.3.1	Null Character Identification (Strlen equivalent)	14-6
14.3.2	White-Space-Like Character Identification	14-9
14.3.3	Substring Searches	14-11
14.3.4	String Token Extraction and Case Handling	14-18
14.3.5	Unicode Processing and PCMPxSTRy	14-22
14.3.6	Replacement String Library Function Using SSE4.2	14-26
14.4	SSE4.2 ENABLED NUMERICAL AND LEXICAL COMPUTATION	14-28
14.5	NUMERICAL DATA CONVERSION TO ASCII FORMAT	14-34
14.5.1	Large Integer Numeric Computation	14-48
14.5.1.1	MULX Instruction and Large Integer Numeric Computation	14-48

CHAPTER 15 OPTIMIZATIONS FOR INTEL® AVX, FMA AND AVX2

15.1	INTEL® AVX INTRINSICS CODING	15-2
15.1.1	Intel® AVX Assembly Coding	15-4
15.2	NON-DESTRUCTIVE SOURCE (NDS)	15-6
15.3	MIXING AVX CODE WITH SSE CODE	15-7
15.3.1	Mixing Intel® AVX and Intel SSE in Function Calls	15-9
15.4	128-BIT LANE OPERATION AND AVX	15-10
15.4.1	Programming With the Lane Concept	15-11
15.4.2	Strided Load Technique	15-11
15.4.3	The Register Overlap Technique	15-14
15.5	DATA GATHER AND SCATTER	15-15
15.5.1	Data Gather	15-15
15.5.2	Data Scatter	15-17
15.6	DATA ALIGNMENT FOR INTEL® AVX	15-19
15.6.1	Align Data to 32 Bytes	15-19
15.6.2	Consider 16-Byte Memory Access when Memory is Unaligned	15-20
15.6.3	Prefer Aligned Stores Over Aligned Loads	15-22
15.7	L1D CACHE LINE REPLACEMENTS	15-22
15.8	4K ALIASING	15-23
15.9	CONDITIONAL SIMD PACKED LOADS AND STORES	15-23
15.9.1	Conditional Loops	15-24
15.10	MIXING INTEGER AND FLOATING-POINT CODE	15-26
15.11	HANDLING PORT 5 PRESSURE	15-29
15.11.1	Replace Shuffles with Blends	15-29
15.11.2	Design Algorithm With Fewer Shuffles	15-31
15.11.3	Perform Basic Shuffles on Load Ports	15-34
15.12	DIVIDE AND SQUARE ROOT OPERATIONS	15-35
15.12.1	Single-Precision Divide	15-37
15.12.2	Single-Precision Reciprocal Square Root	15-38
15.12.3	Single-Precision Square Root	15-40
15.13	OPTIMIZATION OF ARRAY SUB SUM EXAMPLE	15-42
15.14	HALF-PRECISION FLOATING-POINT CONVERSIONS	15-44
15.14.1	Packed Single-Precision to Half-Precision Conversion	15-45
15.14.2	Packed Half-Precision to Single-Precision Conversion	15-46
15.14.3	Locality Consideration for using Half-Precision FP to Conserve Bandwidth	15-46
15.15	FUSED MULTIPLY-ADD (FMA) INSTRUCTIONS GUIDELINES	15-47
15.15.1	Optimizing Throughput with FMA and Floating-Point Add/MUL	15-48
15.15.2	Optimizing Throughput with Vector Shifts	15-50
15.16	AVX2 OPTIMIZATION GUIDELINES	15-51
15.16.1	Multi-Buffering and AVX2	15-55
15.16.2	Modular Multiplication and AVX2	15-55
15.16.3	Data Movement Considerations	15-56
15.16.3.1	SIMD Heuristics to implement Memcpy()	15-56
15.16.3.2	Memcpy() Implementation Using Enhanced REP MOVSB	15-57
15.16.3.3	Memset() Implementation Considerations	15-57
15.16.3.4	Hoisting Memcpy/Memset Ahead of Consuming Code	15-58
15.16.3.5	256-bit Fetch versus Two 128-bit Fetches	15-59
15.16.3.6	Mixing MULX and AVX2 Instructions	15-59
15.16.4	Considerations for Gather Instructions	15-65
15.16.4.1	Strided Loads	15-68
15.16.4.2	Adjacent Loads	15-69
15.16.5	AVX2 Conversion Remedy to MMX Instruction Throughput Limitation	15-71

CHAPTER 16 INTEL® TSX RECOMMENDATIONS

16.1	INTRODUCTION	16-1
16.1.1	Optimization Outline	16-2
16.2	APPLICATION-LEVEL TUNING AND OPTIMIZATIONS	16-2
16.2.1	Existing TSX-enabled Locking Libraries	16-3
16.2.1.1	Libraries allowing lock elision for unmodified programs	16-3
16.2.1.2	Libraries requiring program modifications	16-3
16.2.2	Initial Checks	16-3

16.2.3	Run and Profile the Application	16-3
16.2.4	Minimize Transactional Aborts	16-4
16.2.4.1	Transactional Aborts due to Data Conflicts	16-5
16.2.4.2	Transactional Aborts due to Limited Transactional Resources	16-6
16.2.4.3	Lock Elision Specific Transactional Aborts	16-7
16.2.4.4	HLE Specific Transactional Aborts	16-7
16.2.4.5	Miscellaneous Transactional Aborts	16-8
16.2.5	Using Transactional-Only Code Paths	16-9
16.2.6	Dealing with Transactional Regions or Paths that Abort at a High Rate	16-9
16.2.6.1	Transitioning to Non-Elided Execution without Aborting	16-9
16.2.6.2	Forcing an Early Abort	16-10
16.2.6.3	Not Eliding Selected Locks	16-10
16.3	DEVELOPING AN INTEL TSX ENABLED SYNCHRONIZATION LIBRARY	16-10
16.3.1	Adding HLE Prefixes	16-10
16.3.2	Elision Friendly Critical Section Locks	16-10
16.3.3	Using HLE or RTM for Lock Elision	16-11
16.3.4	An example wrapper for lock elision using RTM	16-11
16.3.5	Guidelines for the RTM fallback handler	16-12
16.3.6	Implementing Elision-Friendly Locks using Intel® TSX	16-13
16.3.6.1	Implementing a Simple Spinlock using HLE	16-13
16.3.6.2	Implementing Reader-Writer Locks using Intel TSX	16-15
16.3.6.3	Implementing Ticket Locks using Intel® TSX	16-15
16.3.6.4	Implementing Queue-Based Locks using Intel® TSX	16-15
16.3.7	Eliding Application-Specific Meta-Locks using Intel® TSX	16-16
16.3.8	Avoiding Persistent Non-Elided Execution	16-17
16.3.9	Reading the Value of an Elided Lock in RTM-based libraries	16-19
16.3.10	Intermixing HLE and RTM	16-19
16.4	USING THE PERFORMANCE MONITORING SUPPORT FOR INTEL® TSX	16-20
16.4.1	Measuring Transactional Success	16-21
16.4.2	Finding locks to elide and verifying all locks are elided	16-21
16.4.3	Sampling Transactional Aborts	16-21
16.4.4	Classifying Aborts using a Profiling Tool	16-21
16.4.5	XABORT Arguments for RTM fallback handlers	16-22
16.4.6	Call Graphs for Transactional Aborts	16-23
16.4.7	Last Branch Records and Transactional Aborts	16-23
16.4.8	Profiling and Testing Intel TSX Software using the Intel® SDE	16-23
16.4.9	HLE Specific Performance Monitoring Events	16-24
16.4.10	Computing Useful Metrics for Intel® TSX	16-25
16.5	PERFORMANCE GUIDELINES	16-25
16.6	DEBUGGING GUIDELINES	16-26
16.7	COMMON INTRINSICS FOR INTEL® TSX	16-26
16.7.1	RTM C Intrinsics	16-26
16.7.1.1	Emulated RTM intrinsics on older gcc compatible compilers	16-27
16.7.2	HLE Intrinsics on gcc and Other Linux Compatible Compilers	16-28
16.7.2.1	Generating HLE intrinsics with gcc4.8	16-28
16.7.2.2	C++11 atomic support	16-29
16.7.2.3	Emulating HLE intrinsics with older gcc-compatible compilers	16-29
16.7.3	HLE intrinsics on Windows C/C++ compilers	16-29

CHAPTER 17

POWER OPTIMIZATION FOR MOBILE USAGES

17.1	OVERVIEW	17-1
17.2	MOBILE USAGE SCENARIOS	17-1
17.2.1	Intelligent Energy Efficient Software	17-2
17.3	ACPI C-STATES	17-3
17.3.1	Processor-Specific C4 and Deep C4 States	17-4
17.3.2	Processor-Specific Deep C-States and Intel® Turbo Boost Technology	17-4
17.3.3	Processor-Specific Deep C-States for Sandy Bridge Microarchitecture	17-5
17.3.4	Intel® Turbo Boost Technology 2.0	17-6
17.4	GUIDELINES FOR EXTENDING BATTERY LIFE	17-6
17.4.1	Adjust Performance to Meet Quality of Features	17-6
17.4.2	Reducing Amount of Work	17-7
17.4.3	Platform-Level Optimizations	17-7
17.4.4	Handling Sleep State Transitions	17-8

17.4.5	Using Enhanced Intel SpeedStep® Technology	17-8
17.4.6	Enabling Intel® Enhanced Deeper Sleep	17-9
17.4.7	Multicore Considerations	17-10
17.4.7.1	Enhanced Intel SpeedStep® Technology	17-10
17.4.7.2	Thread Migration Considerations	17-10
17.4.7.3	Multicore Considerations for C-States	17-11
17.5	TUNING SOFTWARE FOR INTELLIGENT POWER CONSUMPTION	17-12
17.5.1	Reduction of Active Cycles	17-12
17.5.1.1	Multi-threading to reduce Active Cycles	17-12
17.5.1.2	Vectorization	17-13
17.5.2	PAUSE and Sleep(0) Loop Optimization	17-14
17.5.3	Spin-Wait Loops	17-15
17.5.4	Using Event Driven Service Instead of Polling in Code	17-15
17.5.5	Reducing Interrupt Rate	17-15
17.5.6	Reducing Privileged Time	17-15
17.5.7	Setting Context Awareness in the Code	17-16
17.5.8	Saving Energy by Optimizing for Performance	17-17
17.6	PROCESSOR SPECIFIC POWER MANAGEMENT OPTIMIZATION FOR SYSTEM SOFTWARE	17-17
17.6.1	Power Management Recommendation of Processor-Specific Inactive State Configurations	17-17
17.6.1.1	Balancing Power Management and Responsiveness of Inactive To Active State Transitions	17-19

CHAPTER 18

SOFTWARE OPTIMIZATION FOR INTEL® AVX-512 INSTRUCTIONS

18.1	BASIC INTEL® AVX-512 VS. INTEL® AVX2 CODING	18-2
18.1.1	Intrinsic Coding	18-2
18.1.2	Assembly Coding	18-4
18.2	MASKING	18-6
18.2.1	Masking Example	18-7
18.2.2	Masking Cost	18-11
18.2.3	Masking vs. Blending	18-11
18.2.4	Nested Conditions / Mask Aggregation	18-13
18.2.5	Memory Masking Microarchitecture Improvements	18-14
18.2.6	Peeling and Remainder Masking	18-15
18.3	FORWARDING AND UNMASKED OPERATIONS	18-16
18.4	FORWARDING AND MEMORY MASKING	18-17
18.5	DATA COMPRESS	18-17
18.5.1	Data Compress Example	18-18
18.6	DATA EXPAND	18-22
18.6.1	Data Expand Example	18-23
18.7	TERNARY LOGIC	18-25
18.7.1	Ternary Logic Example 1	18-25
18.7.2	Ternary Logic Example 2	18-27
18.8	NEW SHUFFLE INSTRUCTIONS	18-28
18.8.1	Two Source Permute Example	18-29
18.9	BROADCAST	18-32
18.9.1	Embedded Broadcast	18-32
18.9.2	Broadcast Executed on Load Ports	18-32
18.10	EMBEDDED ROUNDING	18-33
18.10.1	Static Rounding Mode	18-33
18.11	SCATTER INSTRUCTION	18-35
18.11.1	Data Scatter Example	18-35
18.12	STATIC ROUNDING MODES, SUPPRESS-ALL-EXCEPTIONS (SAE)	18-38
18.13	QWORD INSTRUCTION SUPPORT	18-38
18.13.1	QUADWORD Support in Arithmetic Instructions	18-39
18.13.2	QUADWORD Support in Convert Instructions	18-42
18.13.3	QUADWORD Support for Convert with Truncation Instructions	18-43
18.14	VECTOR LENGTH ORTHOGONALITY	18-43
18.15	INTEL® AVX-512 INSTRUCTIONS FOR TRANSCENDENTAL SUPPORT	18-43
18.15.1	VRCP14, VRSQRT14 - Software Sequences for 1/x, x/y, sqrt(x)	18-43
18.15.1.1	Application Examples	18-43
18.15.2	VGETMANT VGETEXP - Vector Get Mantissa and Vector Get Exponent	18-44

18.15.2.1	Application Examples	18-44
18.15.3	VRNDSCALE - Vector Round Scale	18-44
18.15.3.1	Application Examples	18-44
18.15.4	VREDUCE - Vector Reduce	18-45
18.15.4.1	Application Examples	18-45
18.15.5	VSCALEF - Vector Scale	18-45
18.15.5.1	Application Examples	18-45
18.15.6	VFPCLASS - Vector Floating Point Class	18-46
18.15.6.1	Application Examples	18-46
18.15.7	VPERM, VPERM12, VPERMT2 - Small Table Lookup Implementation	18-46
18.15.7.1	Application Examples	18-46
18.16	CONFLICT DETECTION	18-46
18.16.1	Vectorization with Conflict Detection	18-47
18.16.2	Sparse Dot Product with VPCONFLICT	18-51
18.17	INTEL® AVX-512 VECTOR BYTE MANIPULATION INSTRUCTIONS (VBMI)	18-53
18.17.1	Permute Packet Bytes Elements Across Lanes (VPERMB)	18-54
18.17.2	Two-Source Byte Permute Across Lanes (VPERM12B, VPERMT2B)	18-55
18.17.3	Select Packed Unaligned Bytes from Quadword Sources (VPMULTISHIFTQB)	18-58
18.18	FMA LATENCY	18-60
18.19	MIXING INTEL® AVX EXTENSIONS OR INTEL® AVX-512 EXTENSIONS WITH INTEL® STREAMING SIMD EXTENSIONS (INTEL® SSE) CODE	18-61
18.20	MIXING ZMM VECTOR CODE WITH XMM/YMM	18-62
18.21	SERVERS WITH A SINGLE FMA UNIT	18-63
18.22	GATHER/SCATTER TO SHUFFLE (G2S/STS)	18-68
18.22.1	Gather to Shuffle in Strided Loads	18-68
18.22.2	Scatter to Shuffle in Strided Stores	18-69
18.22.3	Gather to Shuffle in Adjacent Loads	18-70
18.23	DATA ALIGNMENT	18-71
18.23.1	Align Data to 64 Bytes	18-71
18.24	DYNAMIC MEMORY ALLOCATION AND MEMORY ALIGNMENT	18-73
18.25	DIVISION AND SQUARE ROOT OPERATIONS	18-73
18.25.1	Divide and Square Root Approximation Methods	18-74
18.25.2	Divide and Square Root Performance	18-75
18.25.3	Approximation Latencies	18-75
18.25.4	Code Snippets	18-78
18.26	CLDEMOTE	18-84
18.26.1	Producer-Consumer Communication in Software	18-84
18.27	TIPS ON COMPILER USAGE	18-85

CHAPTER 19

INTEL® ADVANCED VECTOR EXTENSIONS 512 - FP16 INSTRUCTION SET FOR INTEL® XEON® PROCESSORS

19.1	INTRODUCTION	19-1
19.1.1	Terminology	19-1
19.2	OVERVIEW	19-2
19.3	FP16 NUMERIC INSTRUCTIONS	19-3
19.3.1	Data Type Support	19-3
19.3.2	Overview of Intrinsics	19-4
19.3.3	Fundamental Complex-Valued Support	19-5
19.3.4	Using Intel® AVX-512 Bit Masks for Real-Valued Operations	19-6
19.3.5	Using Intel® AVX-512 Bit Masks for Complex-Valued Operations	19-7
19.4	NUMERICS	19-9
19.4.1	Introduction to FP16 Number Format	19-10
19.4.2	Observations on Representing Numbers in FP16 Format	19-10
19.4.3	Numeric Accuracy Guarantees	19-12
19.4.4	Handling Denormal Values	19-13
19.4.5	Embedded Rounding	19-13
19.4.6	Legacy FP16 Data Type Conversion	19-14
19.4.7	FP16 Conversions to and from Other Data Types	19-14
19.4.8	Approximation Instructions and Their Uses	19-15
19.4.8.1	Approximate Reciprocal	19-15
19.4.8.2	Approximate Division	19-15
19.4.8.3	Approximate Reciprocal Square Root	19-16

19.4.9	Approximate Square Root	19-17
19.5	USING EXISTING INTEL® AVX-512 INSTRUCTIONS TO AUGMENT FP16 SUPPORT ...	19-17
19.5.1	Using Existing Instructions to Extend Intel® AVX-512 FP16 Intrinsics	19-17
19.5.2	Common Convenience Intrinsics	19-18
19.5.3	Using Integer Comparisons for Fast Floating-Point Comparison	19-18
19.6	MATH LIBRARY SUPPORT	19-19

CHAPTER 20

INTEL® ADVANCED MATRIX EXTENSIONS (INTEL® AMX)

20.1	DETECTING INTEL® AMX SUPPORT	20-2
20.2	INTEL® AMX MICROARCHITECTURE OVERVIEW	20-2
20.2.1	Intel AMX Frequencies	20-2
20.3	INTEL® AMX INSTRUCTIONS THROUGHPUT AND LATENCY	20-3
20.4	DATA STRUCTURE ALIGNMENT	20-3
20.5	GEMMS / CONVOLUTIONS	20-4
20.5.1	Notation	20-4
20.5.2	Tiles in the Intel® AMX Architecture	20-4
	TileLoad and TileStore Instructions	20-5
20.5.3	B Matrix Layout	20-6
20.5.4	Straightforward GEMM Implementation	20-8
20.5.5	Optimizations	20-10
20.5.5.1	Minimizing Tile Loads	20-10
	Location of the K Loop: Outside of the M_ACC and N_ACC Loops	20-10
	Pre-loading Innermost Loop Tiles	20-10
	2D Accumulator Array vs. 1D Accumulator Array	20-11
20.5.5.2	Software Pipelining of Tile Loads and Stores	20-12
20.5.5.3	Optimized GEMM Implementation	20-12
	Variable Input Dimensions	20-15
20.5.5.4	Direct Convolution with Intel® AMX	20-15
	Activations Layout	20-15
	Weights Layout	20-16
20.5.5.5	Convolution - Matrix-like Multiplications and Summations Equivalence	20-17
20.5.5.6	Optimized Convolution Implementation	20-19
	Location of the KH, KW Loops	20-21
20.6	CACHE BLOCKING	20-21
20.6.1	Optimized Convolution Implementation with Cache Blocking	20-21
	Intel AMX-Specific Considerations	20-23
20.7	MINI-BATCHING IN LARGE BATCH INFERENCE	20-24
20.8	NON-TEMPORAL TILE LOADS	20-25
	Priority Inversion Scenarios with Temporal Loads	20-25
	Scenario 1:	20-25
	Scenario 2:	20-26
	Solution to Priority Inversions: Non-temporal Loads	20-27
20.9	USING LARGE TILES IN SMALL CONVOLUTIONS TO MAXIMIZE DATA REUSE	20-27
20.10	HANDLING INCONVENIENTLY SIZED ACTIVATIONS	20-28
20.11	POST-CONVOLUTION OPTIMIZATIONS	20-29
20.11.1	Post-convolution Fusion	20-29
20.11.2	Intel® AMX and Intel® AVX-512 Interleaving (SW Pipelining)	20-32
20.11.3	AVOIDING THE H/W OVERHEAD OF PORT 5 FREQUENT OPEN/CLOSE OPERATIONS	20-34
20.11.4	Post-Conv Multiple OFM Accumulation and Efficient Down-Conversion	20-35
20.12	INPUT AND OUTPUT BUFFERS REUSE (AKA DOUBLE BUFFERING)	20-37
20.13	SOFTWARE PREFETCHES	20-38
20.13.1	Software Prefetch for Convolution and GEMM Layers	20-38
20.13.1.1	The Prefetch Strategy	20-38
20.13.1.2	Prefetch Distance	20-39
20.13.1.3	To Prefetch A or Prefetch B?	20-39
20.13.1.4	To Prefetch or not to Prefetch C?	20-40
20.13.2	Software Prefetch for Embedding Layer	20-40
20.14	STORE TO LOAD FORWARDING	20-40
20.15	MATRIX TRANSPOSE	20-41
20.15.1	Flat-to-Flat Transpose of BF16 Data	20-41

20.15.2	VNNI-to-VNNI Transpose	20-46
20.15.3	Flat-to-VNNI Transpose	20-48
20.15.4	Flat-to-VNNI Re-layout	20-52
20.16	MULTI-THREADING CONSIDERATIONS	20-53
20.16.1	Thread Affinity	20-53
20.16.2	Hyper-Threading	20-53
20.16.3	Work Partitioning Between Cores	20-53
20.16.3.1	Partitioning over M	20-54
20.16.3.2	Partitioning over N	20-54
20.16.3.3	Partitioning over K	20-55
20.16.3.4	Memory Bandwidth Implications of Work Partitioning over Multiple Dimensions	20-55
20.16.4	Recommendation System Example	20-56
20.17	SPARSITY OPTIMIZATIONS FOR INTEL® AMX	20-58
20.18	TILECONFIG/TILERELASE, CORE C-STATE, AND COMPILER ABI	20-60
20.18.1	ABI	20-60
20.18.2	Intrinsics	20-60
20.18.3	User Interface	20-61
20.18.4	Example	20-63
20.18.5	Compilation Option	20-65
20.19	INTEL® AMX STATE MANAGEMENT	20-66
20.19.1	Extended Feature Disable (XFD)	20-67
20.19.2	Alternate Signal Handler Stack in Linux Operating System	20-67
20.20	USING INTEL® AMX TO EMULATE HIGHER PRECISION GEMMS	20-67

CHAPTER 21

CRYPTOGRAPHY & FINITE FIELD ARITHMETIC ENHANCEMENTS

21.1	VECTOR AES	21-1
21.2	VPCLMULQDQ	21-2
21.3	GALOIS FIELD NEW INSTRUCTIONS	21-2
21.4	INTEGER FUSED MULTIPLY ACCUMULATE OPERATIONS (AVX512_IFMA - VPMADD52)	21-3

CHAPTER 22

INTEL® QUICKASSIST TECHNOLOGY

22.1	SOFTWARE DESIGN GUIDELINES	22-1
22.1.1	Polling vs. Interrupts (If Supported)	22-1
22.1.1.1	Interrupt Mode	22-1
22.1.1.2	Polling Mode	22-2
22.1.1.3	Recommendations	22-3
22.1.2	Use of Data Plane (DP) API vs. Traditional API	22-3
22.1.2.1	Batch Submission of Requests Using the Data Plane API	22-3
22.1.3	Synchronous (sync) vs. Asynchronous (async)	22-3
22.1.4	Buffer Lists	22-4
22.1.5	Maximum Number of Concurrent Requests	22-4
22.1.6	Symmetric Crypto Partial Operations	22-5
22.1.7	Reusing Sessions in QAT Environment	22-5
22.1.8	Maximizing QAT Device Utilization	22-5
22.1.9	Best Known Method (BKM) for Avoiding Performance Bottlenecks	22-5
22.1.10	Avoid Data Copies By Using SVM and ATS	22-6
22.1.11	Avoid Page Faults When Using SVM	22-6

CHAPTER 23

KNIGHTS LANDING MICROARCHITECTURE AND SOFTWARE OPTIMIZATION

23.1	KNIGHTS LANDING MICROARCHITECTURE	23-2
23.1.1	Front End	23-3
23.1.2	Out-of-Order Engine	23-3
23.1.3	UnTile	23-6
23.2	INTEL® AVX-512 CODING RECOMMENDATIONS FOR KNIGHTS LANDING MICROARCHITECTURE	23-7
23.2.1	Using Gather and Scatter Instructions	23-8
23.2.2	Using Enhanced Reciprocal Instructions	23-8

23.2.3	Using AVX-512CD Instructions	23-9
23.2.4	Using Intel® Hyper-Threading Technology	23-9
23.2.5	Front End Considerations	23-9
23.2.5.1	Instruction Decoder	23-10
23.2.5.2	Branching Indirectly Across a 4GB Boundary	23-10
23.2.6	Integer Execution Considerations	23-10
23.2.6.1	Flags usage	23-10
23.2.6.2	Integer Division	23-11
23.2.7	Optimizing FP and Vector Execution	23-11
23.2.7.1	Instruction Selection Considerations	23-11
23.2.7.2	Porting Intrinsics from Previous Generation	23-13
23.2.7.3	Vectorization Trade-Off Estimation	23-13
23.2.8	Memory Optimization	23-16
23.2.8.1	Data Alignment	23-16
23.2.8.2	Hardware Prefetcher	23-17
23.2.8.3	Software Prefetch	23-17
23.2.8.4	Memory Execution Cluster	23-17
23.2.8.5	Store Forwarding	23-18
23.2.8.6	Way, Set Conflicts	23-18
23.2.8.7	Streaming Store Versus Regular Store	23-19
23.2.8.8	Compiler Switches and Directives	23-19
23.2.8.9	Direct Mapped MCDRAM Cache	23-19

APPENDIX A APPLICATION PERFORMANCE TOOLS

A.1	COMPILERS	A-2
A.1.1	Recommended Optimization Settings for Intel® 64 and IA-32 Processors	A-2
A.1.2	Vectorization and Loop Optimization	A-3
A.1.2.1	Multithreading with OpenMP*	A-3
A.1.2.2	Automatic Multithreading	A-3
A.1.3	Inline Expansion of Library Functions (/Oi, /Oi-)	A-3
A.1.4	Interprocedural and Profile-Guided Optimizations	A-3
A.1.4.1	Interprocedural Optimization (IPO)	A-3
A.1.4.2	Profile-Guided Optimization (PGO)	A-4
A.1.5	Intel® Cilk™ Plus	A-4
A.2	PERFORMANCE LIBRARIES	A-4
A.2.1	Intel® Integrated Performance Primitives (Intel® IPP)	A-5
A.2.2	Intel® Math Kernel Library (Intel® MKL)	A-5
A.2.3	Intel® Threading Building Blocks (Intel® TBB)	A-5
A.2.4	Benefits Summary	A-5
A.3	PERFORMANCE PROFILERS	A-5
A.3.1	Intel® VTune™ Amplifier XE	A-6
A.3.1.1	Hardware Event-Based Sampling Analysis	A-6
A.3.1.2	Algorithm Analysis	A-6
A.3.1.3	Platform Analysis	A-6
A.4	THREAD AND MEMORY CHECKERS	A-6
A.4.1	Intel® Inspector	A-7
A.5	VECTORIZATION ASSISTANT	A-7
A.5.1	Intel® Advisor	A-7
A.6	CLUSTER TOOLS	A-7
A.6.1	Intel® Trace Analyzer and Collector	A-7
A.6.1.1	MPI Performance Snapshot	A-7
A.6.2	Intel® MPI Library	A-7
A.6.3	Intel® MPI Benchmarks	A-8
A.7	INTEL® ACADEMIC COMMUNITY	A-8

APPENDIX B USING PERFORMANCE MONITORING EVENTS

B.1	TOP-DOWN ANALYSIS METHOD	B-1
B.1.1	Top-Level	B-2
B.1.2	Frontend Bound	B-4
B.1.3	Backend Bound	B-4

B.1.4	Memory Bound	B-4
B.1.5	Core Bound	B-5
B.1.6	Bad Speculation	B-5
B.1.7	Retiring	B-6
B.1.8	Golden Cove Microarchitecture	B-6
B.1.9	Ice Lake Microarchitecture	B-6
B.1.10	Optane Persistent Memory	B-6
B.1.11	Skylake Microarchitecture	B-6
B.1.11.1	TMA Use Case 1	B-7
B.1.11.2	TMA Use Case 2	B-7
B.2	PERFORMANCE MONITORING AND MICROARCHITECTURE	B-8
B.3	INTEL® XEON® PROCESSOR 5500 SERIES	B-14
B.4	PERFORMANCE ANALYSIS TECHNIQUES FOR INTEL® XEON® PROCESSOR 5500 SERIES	B-15
B.4.1	Cycle Accounting and Uop Flow Analysis	B-16
B.4.1.1	Cycle Drill Down and Branch Mispredictions	B-17
B.4.1.2	Basic Block Drill Down	B-20
B.4.2	Stall Cycle Decomposition and Core Memory Accesses	B-21
B.4.2.1	Measuring Costs of Microarchitectural Conditions	B-21
B.4.3	Core PMU Precise Events	B-22
B.4.3.1	Precise Memory Access Events	B-23
B.4.3.2	Load Latency Event	B-24
B.4.3.3	Precise Execution Events	B-26
B.4.3.4	Last Branch Record (LBR)	B-27
B.4.3.5	Measuring Per-Core Bandwidth	B-31
B.4.3.6	Miscellaneous L1 and L2 Events for Cache Misses	B-32
B.4.3.7	TLB Misses	B-32
B.4.3.8	L1 Data Cache	B-33
B.4.4	Frontend Monitoring Events	B-33
B.4.4.1	Branch Mispredictions	B-33
B.4.4.2	Frontend Code Generation Metrics	B-33
B.4.5	Uncore Performance Monitoring Events	B-34
B.4.5.1	Global Queue Occupancy	B-34
B.4.5.2	Global Queue Port Events	B-36
B.4.5.3	Global Queue Snoop Events	B-36
B.4.5.4	L3 Events	B-37
B.4.6	Intel QuickPath Interconnect Home Logic (QHL)	B-37
B.4.7	Measuring Bandwidth From the Uncore	B-42
B.5	PERFORMANCE TUNING TECHNIQUES FOR SANDY BRIDGE MICROARCHITECTURE	B-43
B.5.1	Correlating Performance Bottleneck to Source Location	B-43
B.5.2	Hierarchical Top-Down Performance Characterization Methodology and Locating Performance Bottlenecks	B-44
B.5.2.1	Back End Bound Characterization	B-45
B.5.2.2	Core Bound Characterization	B-45
B.5.2.3	Memory Bound Characterization	B-46
B.5.3	Back End Stalls	B-47
B.5.4	Memory Sub-System Stalls	B-48
B.5.4.1	Accounting for Load Latency	B-48
B.5.4.2	Cache-line Replacement Analysis	B-50
B.5.4.3	Lock Contention Analysis	B-50
B.5.4.4	Other Memory Access Issues	B-51
B.5.5	Execution Stalls	B-53
B.5.5.1	Longer Instruction Latencies	B-53
B.5.5.2	Assists	B-53
B.5.6	Bad Speculation	B-54
B.5.6.1	Branch Mispredicts	B-54
B.5.7	Frontend Stalls	B-54
B.5.7.1	Understanding the Micro-op Delivery Rate	B-54
B.5.7.2	Understanding the Sources of the Micro-op Queue	B-56
B.5.7.3	The Decoded ICache	B-57
B.5.7.4	Issues in the Legacy Decode Pipeline	B-58
B.5.7.5	Instruction Cache	B-58
B.6	USING PERFORMANCE EVENTS OF INTEL® CORE™ SOLO AND INTEL® CORE™ DUO PROCESSORS	B-59
B.6.1	Understanding the Results in a Performance Counter	B-59
B.6.2	Ratio Interpretation	B-59

B.6.3	Notes on Selected Events	B-60
B.7	DRILL-DOWN TECHNIQUES FOR PERFORMANCE ANALYSIS	B-60
B.7.1	Cycle Composition at Issue Port	B-62
B.7.2	Cycle Composition of OOO Execution	B-62
B.7.3	Drill-Down on Performance Stalls	B-63
B.8	EVENT RATIOS FOR INTEL CORE MICROARCHITECTURE	B-64
B.8.1	Clocks Per Instructions Retired Ratio (CPI)	B-64
B.8.2	Front End Ratios	B-65
B.8.2.1	Code Locality	B-65
B.8.2.2	Branching and Front End	B-65
B.8.2.3	Stack Pointer Tracker	B-65
B.8.2.4	Macro-fusion	B-66
B.8.2.5	Length Changing Prefix (LCP) Stalls	B-66
B.8.2.6	Self Modifying Code Detection	B-66
B.8.3	Branch Prediction Ratios	B-66
B.8.3.1	Branch Mispredictions	B-66
B.8.3.2	Virtual Tables and Indirect Calls	B-66
B.8.3.3	Mispredicted Returns	B-67
B.8.4	Execution Ratios	B-67
B.8.4.1	Resource Stalls	B-67
B.8.4.2	ROB Read Port Stalls	B-67
B.8.4.3	Partial Register Stalls	B-67
B.8.4.4	Partial Flag Stalls	B-67
B.8.4.5	Bypass Between Execution Domains	B-67
B.8.4.6	Floating-Point Performance Ratios	B-68
B.8.5	Memory Sub-System - Access Conflicts Ratios	B-68
B.8.5.1	Loads Blocked by the L1 Data Cache	B-68
B.8.5.2	4K Aliasing and Store Forwarding Block Detection	B-68
B.8.5.3	Load Block by Preceding Stores	B-68
B.8.5.4	Memory Disambiguation	B-69
B.8.5.5	Load Operation Address Translation	B-69
B.8.6	Memory Sub-System - Cache Misses Ratios	B-69
B.8.6.1	Locating Cache Misses in the Code	B-69
B.8.6.2	L1 Data Cache Misses	B-69
B.8.6.3	L2 Cache Misses	B-69
B.8.7	Memory Sub-system - Prefetching	B-70
B.8.7.1	L1 Data Prefetching	B-70
B.8.7.2	L2 Hardware Prefetching	B-70
B.8.7.3	Software Prefetching	B-70
B.8.8	Memory Sub-system - TLB Miss Ratios	B-70
B.8.9	Memory Sub-system - Core Interaction	B-71
B.8.9.1	Modified Data Sharing	B-71
B.8.9.2	Fast Synchronization Penalty	B-71
B.8.9.3	Simultaneous Extensive Stores and Load Misses	B-71
B.8.10	Memory Sub-system - Bus Characterization	B-71
B.8.10.1	Bus Utilization	B-71
B.8.10.2	Modified Cache Lines Eviction	B-72

APPENDIX C

RUNTIME PERFORMANCE OPTIMIZATION BLUEPRINT: INTEL® ARCHITECTURE OPTIMIZATION WITH LARGE CODE PAGES

C.1	OVERVIEW	C-1
C.1.1	ITLBs and Stalls	C-2
C.1.2	Large Pages	C-3
C.2	DIAGNOSING THE PROBLEM	C-3
C.2.1	ITLB Misses	C-3
C.2.2	Measuring the ITLB Miss Stall	C-5
C.2.3	Source of ITLB Misses	C-6
C.3	SOLUTION	C-6
C.3.1	Linux* and Large Pages	C-6
C.3.2	Large Pages for .text	C-7
C.3.3	Reference Code	C-7
C.3.4	Large Pages for the Heap	C-8

C.4	SOLUTION INTEGRATION	C-9
C.4.1	V8 Integration with the Reference Implementation	C-9
C.4.2	JAVA JVM Integration with the Reference Implementation	C-9
C.5	LIMITATIONS	C-10
C.6	CASE STUDY	C-10
C.6.1	Ghost.js Workload	C-11
C.6.2	Web Tooling Workload	C-11
C.6.2.1	Node Version	C-11
C.6.2.2	Web Tooling	C-11
C.6.2.3	Comparing Clear Linux* OS and Ubuntu*	C-11
C.6.3	MediaWiki Workload	C-12
C.6.4	Visualization of Benefits	C-13
C.6.4.1	Precise Events	C-13
C.6.4.2	Visualizing Precise ITLB Miss	C-13
C.7	SUMMARY	C-16
C.8	TEST CONFIGURATION DETAILS	C-16
C.9	ADDITIONAL REFERENCES	C-17

APPENDIX D

INSTRUCTION LATENCY AND THROUGHPUT

D.1	OVERVIEW	D-1
D.2	DEFINITIONS	D-2
D.3	LATENCY AND THROUGHPUT	D-2
D.3.1	Latency and Throughput with Register Operands	D-3
D.3.2	Table Footnotes	D-18
D.3.3	Instructions with Memory Operands	D-19
D.3.3.1	Software Observable Latency of Memory References	D-19

APPENDIX E

EARLIER GENERATIONS OF INTEL® 64 AND IA-32 PROCESSOR ARCHITECTURES

E.1	HASWELL MICROARCHITECTURE	E-1
E.1.1	The Front End	E-2
E.1.2	The Out-of-Order Engine	E-2
E.1.3	Execution Engine	E-3
E.1.4	Cache and Memory Subsystem	E-5
E.1.4.1	Load and Store Operation Enhancements	E-6
E.1.5	Unlamination	E-6
E.1.6	Haswell-E Microarchitecture	E-7
E.1.7	Broadwell Microarchitecture	E-7
E.2	SANDY BRIDGE MICROARCHITECTURE	E-8
E.2.1	Sandy Bridge Microarchitecture Pipeline Overview	E-9
E.2.2	The Front End	E-10
E.2.2.1	Legacy Decode Pipeline	E-10
E.2.2.2	Decoded ICache	E-12
E.2.2.3	Branch Prediction	E-13
E.2.2.4	Micro-op Queue and the Loop Stream Detector (LSD)	E-14
E.2.3	The Out-of-Order Engine	E-14
E.2.3.1	Renamer	E-15
E.2.3.2	Scheduler	E-16
E.2.4	The Execution Core	E-16
E.2.5	Cache Hierarchy	E-17
E.2.5.1	Load and Store Operation Overview	E-18
E.2.5.2	L1 DCache	E-19
E.2.5.3	Ring Interconnect and Last Level Cache	E-23
E.2.5.4	Data Prefetching	E-24
E.2.6	System Agent	E-25
E.2.7	Ivy Bridge Microarchitecture	E-26
E.3	INTEL® CORE™ MICROARCHITECTURE AND ENHANCED INTEL® CORE™ MICROARCHITECTURE	E-26
E.3.1	Intel® Core™ Microarchitecture Pipeline Overview	E-27
E.3.2	Front End	E-28

E.3.2.1	Branch Prediction Unit	E-29
E.3.2.2	Instruction Fetch Unit	E-29
E.3.2.3	Instruction Queue (IQ)	E-30
E.3.2.4	Instruction Decode	E-31
E.3.2.5	Stack Pointer Tracker	E-31
E.3.2.6	Micro-fusion	E-31
E.3.3	Execution Core	E-31
E.3.3.1	Issue Ports and Execution Units	E-32
E.3.4	Intel® Advanced Memory Access	E-34
E.3.4.1	Loads and Stores	E-35
E.3.4.2	Data Prefetch to L1 caches	E-36
E.3.4.3	Data Prefetch Logic	E-36
E.3.4.4	Store Forwarding	E-37
E.3.4.5	Memory Disambiguation	E-38
E.3.5	Intel® Advanced Smart Cache	E-38
E.3.5.1	Loads	E-39
E.3.5.2	Stores	E-39
E.4	NEHALEM MICROARCHITECTURE	E-40
E.4.1	Microarchitecture Pipeline	E-40
E.4.2	Front End Overview	E-42
E.4.3	Execution Engine	E-43
E.4.3.1	Issue Ports and Execution Units	E-44
E.4.4	Cache and Memory Subsystem	E-45
E.4.5	Load and Store Operation Enhancements	E-46
E.4.5.1	Efficient Handling of Alignment Hazards	E-46
E.4.5.2	Store Forwarding Enhancement	E-46
E.4.6	REP String Enhancement	E-48
E.4.7	Enhancements for System Software	E-49
E.4.8	Efficiency Enhancements for Power Consumption	E-49
E.4.9	Hyper-Threading Technology Support in Nehalem Microarchitecture	E-49

APPENDIX F

EARLIER GENERATIONS OF INTEL ATOM® MICROARCHITECTURE AND SOFTWARE OPTIMIZATION

F.1	OVERVIEW	F-1
F.2	INTEL ATOM® MICROARCHITECTURE	F-1
F.2.1	Hyper-Threading Technology Support in Intel Atom® Microarchitecture	F-3
F.3	CODING RECOMMENDATIONS FOR INTEL ATOM® MICROARCHITECTURE	F-3
F.3.1	Optimization for Front End of Intel Atom® Microarchitecture	F-3
F.3.2	Optimizing the Execution Core	F-5
F.3.2.1	Integer Instruction Selection	F-5
F.3.2.2	Address Generation	F-6
F.3.2.3	Integer Multiply	F-6
F.3.2.4	Integer Shift Instructions	F-7
F.3.2.5	Partial Register Access	F-7
F.3.2.6	FP/SIMD Instruction Selection	F-7
F.3.3	Optimizing Memory Access	F-9
F.3.3.1	Store Forwarding	F-9
F.3.3.2	First-level Data Cache	F-9
F.3.3.3	Segment Base	F-10
F.3.3.4	String Moves	F-10
F.3.3.5	Parameter Passing	F-11
F.3.3.6	Function Calls	F-11
F.3.3.7	Optimization of Multiply/Add Dependent Chains	F-11
F.3.3.8	Position Independent Code	F-13
F.4	INSTRUCTION LATENCY	F-13
F.5	SILVERMONT MICROARCHITECTURE	F-19
F.5.1	Integer Pipeline	F-22
F.5.2	Floating-Point Pipeline	F-22
F.6	GOLDMONT MICROARCHITECTURE	F-23
F.7	GOLDMONT PLUS MICROARCHITECTURE	F-26
F.8	CODING RECOMMENDATIONS	F-29
F.8.1	Optimizing The Front End	F-29

F.8.1.1	Instruction Decoder	F-29
F.8.1.2	Front End High IPC Considerations	F-30
F.8.1.3	Branching Across 4GB Boundary	F-31
F.8.1.4	Loop Unrolling and Loop Stream Detector	F-31
F.8.1.5	Mixing Code and Data	F-32
F.8.2	Optimizing The Execution Core	F-32
F.8.2.1	Scheduling	F-32
F.8.2.2	Address Generation	F-32
F.8.2.3	FP Multiply-Accumulate-Store Execution	F-32
F.8.2.4	Integer Multiply Execution	F-33
F.8.2.5	Zeroing Idioms	F-34
F.8.2.6	NOP Idioms	F-34
F.8.2.7	Move Elimination and ESP Folding	F-34
F.8.2.8	Stack Manipulation Instruction	F-35
F.8.2.9	Flags usage	F-35
F.8.2.10	SIMD Floating-Point and X87 Instructions	F-35
F.8.2.11	SIMD Integer Instructions	F-35
F.8.2.12	Vectorization Considerations	F-36
F.8.2.13	Other SIMD Instructions	F-36
F.8.2.14	Instruction Selection	F-36
F.8.2.15	Integer Division	F-38
F.8.2.16	Integer Shift	F-39
F.8.2.17	Pause Instruction	F-39
F.8.3	Optimizing Memory Accesses	F-39
F.8.3.1	Reduce Unaligned Memory Access with PALIGNR	F-39
F.8.3.2	Minimize Memory Execution Issues	F-40
F.8.3.3	Store Forwarding	F-40
F.8.3.4	PrefetchW Instruction	F-41
F.8.3.5	Cache Line Splits and Alignment	F-41
F.8.3.6	Segment Base	F-41
F.8.3.7	Copy and String Copy	F-42
F.9	INSTRUCTION LATENCY AND THROUGHPUT	F-42

EXAMPLES

Example 2-1.	Class 0 Pseudo-code Snippet	2-4
Example 2-2.	Class 1 Pseudo-code Snippet	2-4
Example 2-3.	Class 2 Pseudo-code Snippet	2-5
Example 2-4.	Class 3 Pseudo-code Snippet	2-5
Example 2-5.	Breaking False Dependency through Zero Idiom	2-13
Example 2-6.	Considering Stores	2-19
Example 2-7.	Rearranging Code to Achieve Store Pairing	2-19
Example 2-8.	Dynamic Pause Loop Example	2-33
Example 2-9.	Contented Locks with Increasing Back-off Example	2-34
Example 3-1.	Assembly Code with an Unpredictable Branch	3-5
Example 3-2.	Code Optimization to Eliminate Branches	3-5
Example 3-3.	Eliminating Branch with CMOV Instruction	3-6
Example 3-4.	Static Branch Prediction Algorithm	3-6
Example 3-5.	Static Taken Prediction	3-7
Example 3-6.	Static Not-Taken Prediction	3-7
Example 3-7.	Indirect Branch With Two Favored Targets	3-9
Example 3-8.	A Peeling Technique to Reduce Indirect Branch Misprediction	3-10
Example 3-9.	Loop Unrolling	3-11
Example 3-10.	Macrofusion, Unsigned Iteration Count	3-14
Example 3-11.	Macrofusion, If Statement	3-14
Example 3-12.	Macrofusion, Signed Variable	3-15
Example 3-13.	Macrofusion, Signed Comparison	3-15
Example 3-14.	Additional Macrofusion Benefit in Sandy Bridge Microarchitecture	3-16
Example 3-15.	Avoiding False LCP Delays with OxF7 Group Instructions	3-17
Example 3-16.	Independent Two-Operand LEA Example	3-21
Example 3-17.	Alternative to Three-Operand LEA	3-22
Example 3-18.	Examples of 512-bit Additions	3-23
Example 3-19.	Clearing Register to Break Dependency While Negating Array Elements	3-26
Example 3-20.	Spill Scheduling Code	3-28
Example 3-21.	Zero-Latency MOV Instructions	3-29
Example 3-22.	Byte-Granular Data Computation Technique	3-29
Example 3-23.	Re-ordering Sequence to Improve Effectiveness of Zero-Latency MOV Instructions	3-30
Example 3-24.	Avoiding Partial Register Stalls in Integer Code	3-32
Example 3-25.	Avoiding Partial Register Stalls in SIMD Code	3-33
Example 3-26.	Avoiding Partial Flag Register Stalls	3-33
Example 3-27.	Partial Flag Register Accesses in Sandy Bridge Microarchitecture	3-34
Example 3-28.	Reference Code Template for Partially Vectorizable Program	3-36
Example 3-29.	Three Alternate Packing Methods for Avoiding Store Forwarding Difficulty	3-37
Example 3-30.	Using Four Registers to Reduce Memory Spills and Simplify Result Passing	3-37
Example 3-31.	Stack Optimization Technique to Simplify Parameter Passing	3-38
Example 3-32.	Base Line Code Sequence to Estimate Loop Overhead	3-39
Example 3-33.	Optimizing for Load Port Bandwidth in Sandy Bridge Microarchitecture	3-41
Example 3-34.	Index versus Pointers in Pointer-Chasing Code	3-42
Example 3-35.	Example of Bank Conflicts in L1D Cache and Remedy	3-43
Example 3-36.	Using XMM Register in Lieu of Memory for Register Spills	3-44
Example 3-37.	Loads Blocked by Stores of Unknown Address	3-45
Example 3-38.	Situations Showing Small Loads After Large Store	3-46
Example 3-39.	Non-forwarding Example of Large Load After Small Store	3-46
Example 3-40.	A Non-forwarding Situation in Compiler Generated Code	3-47
Example 3-41.	Two Ways to Avoid Non-forwarding Situation in Example 3-40	3-47
Example 3-42.	Large and Small Load Stalls	3-47
Example 3-43.	Loop-carried Dependence Chain	3-49
Example 3-44.	Rearranging a Data Structure	3-49
Example 3-45.	Decomposing an Array	3-50
Example 3-46.	Examples of Dynamical Stack Alignment	3-51
Example 3-47.	Instruction Pointer Query Techniques	3-53

Example 3-48.	Using Non-temporal Stores and 64-byte Bus Write Transactions	3-55
Example 3-49.	On-temporal Stores and Partial Bus Write Transactions	3-55
Example 3-50.	Using DCU Hardware Prefetch	3-56
Example 3-51.	Avoid Causing DCU Hardware Prefetch to Fetch Un-needed Lines	3-57
Example 3-52.	Technique For Using L1 Hardware Prefetch	3-58
Example 3-53.	REP STOSD with Arbitrary Count Size and 4-Byte-Aligned Destination	3-60
Example 3-54.	Algorithm to Avoid Changing Rounding Mode	3-68
Example 3-55.	Locking Algorithm for Sapphire Rapids	3-72
Example 3-56.	Fixed Instruction Sequence with Improved Performance on Sapphire Rapids	3-75
Example 3-57.	WordPress/PHP Case Study: with and without 2GB Fix for Branch Misprediction	3-76
Example 3-58.	Identification of WAITPKG with CPUID	3-78
Example 3-59.	Code Snippet in an Asynchronous Example	3-80
Example 5-1.	Identification of MMX Technology with CPUID	5-2
Example 5-2.	Identification of SSE with CPUID	5-2
Example 5-3.	Identification of SSE2 with cpuid	5-3
Example 5-4.	Identification of SSE3 with CPUID	5-3
Example 5-5.	Identification of SSSE3 with cpuid	5-3
Example 5-6.	Identification of SSE4.1 with cpuid	5-4
Example 5-7.	Identification of SSE4.2 with cpuid	5-4
Example 5-8.	Detection of AESNI Instructions	5-5
Example 5-9.	Detection of PCLMULQDQ Instruction	5-5
Example 5-10.	Detection of AVX Instruction	5-6
Example 5-11.	Detection of VEX-Encoded AESNI Instructions	5-7
Example 5-12.	Detection of VEX-Encoded AESNI Instructions	5-7
Example 5-13.	Simple Four-Iteration Loop	5-14
Example 5-14.	Streaming SIMD Extensions Using Inlined Assembly Encoding	5-14
Example 5-15.	Simple Four-Iteration Loop Coded with Intrinsics	5-15
Example 5-16.	C++ Code Using the Vector Classes	5-16
Example 5-17.	Automatic Vectorization for a Simple Loop	5-16
Example 5-18.	C Algorithm for 64-bit Data Alignment	5-18
Example 5-19.	AoS Data Structure	5-21
Example 5-20.	SoA Data Structure	5-21
Example 5-21.	AoS and SoA Code Samples	5-21
Example 5-22.	Hybrid SoA Data Structure	5-22
Example 5-23.	Pseudo-code Before Strip Mining	5-23
Example 5-24.	Strip Mined Code	5-24
Example 5-25.	Loop Blocking	5-24
Example 5-26.	Emulation of Conditional Moves	5-26
Example 6-1.	Resetting Register Between __m64 and FP Data Types Code	6-3
Example 6-2.	FIR Processing Example in C language Code	6-4
Example 6-3.	SSE2 and SSSE3 Implementation of FIR Processing Code	6-4
Example 6-4.	Zero Extend 16-bit Values into 32 Bits Using Unsigned Unpack Instructions Code	6-5
Example 6-5.	Signed Unpack Code	6-5
Example 6-6.	Interleaved Pack with Saturation Code	6-7
Example 6-7.	Interleaved Pack without Saturation Code	6-7
Example 6-8.	Unpacking Two Packed-word Sources in Non-interleaved Way Code	6-9
Example 6-9.	PEXTRW Instruction Code	6-10
Example 6-10.	PINSRW Instruction Code	6-10
Example 6-11.	Repeated PINSRW Instruction Code	6-11
Example 6-12.	Non-Unit Stride Load/Store Using SSE4.1 Instructions	6-11
Example 6-13.	Scatter and Gather Operations Using SSE4.1 Instructions	6-11
Example 6-14.	PMOVMASKB Instruction Code	6-12
Example 6-15.	Broadcast a Word Across XMM, Using 2 SSE2 Instructions	6-13
Example 6-16.	Swap/Reverse words in an XMM, Using 3 SSE2 Instructions	6-13
Example 6-17.	Generating Constants	6-15
Example 6-18.	Absolute Difference of Two Unsigned Numbers	6-15
Example 6-19.	Absolute Difference of Signed Numbers	6-16
Example 6-20.	Computing Absolute Value	6-16
Example 6-21.	Basic C Implementation of RGBA to BGRA Conversion	6-17

Example 6-22.	Color Pixel Format Conversion Using SSE2	6-17
Example 6-23.	Color Pixel Format Conversion Using SSSE3	6-18
Example 6-24.	Big-Endian to Little-Endian Conversion	6-19
Example 6-25.	Clipping to a Signed Range of Words [High, Low]	6-20
Example 6-26.	Clipping to an Arbitrary Signed Range [High, Low]	6-20
Example 6-27.	Simplified Clipping to an Arbitrary Signed Range	6-20
Example 6-28.	Clipping to an Arbitrary Unsigned Range [High, Low]	6-21
Example 6-29.	Complex Multiply by a Constant	6-23
Example 6-30.	Using PTEST to Separate Vectorizable and non-Vectorizable Loop Iterations	6-24
Example 6-31.	Using Variable BLEND to Vectorize Heterogeneous Loops	6-24
Example 6-32.	Baseline C Code for Mandelbrot Set Map Evaluation	6-25
Example 6-33.	Vectorized Mandelbrot Set Map Evaluation Using SSE4.1 Intrinsics	6-26
Example 6-34.	A Large Load after a Series of Small Stores (Penalty)	6-28
Example 6-35.	Accessing Data Without Delay	6-28
Example 6-36.	A Series of Small Loads After a Large Store	6-28
Example 6-37.	Eliminating Delay for a Series of Small Loads after a Large Store	6-29
Example 6-38.	Un-optimized Reverse Memory Copy in C	6-30
Example 6-39.	Using PSHUFB to Reverse Byte Ordering 16 Bytes at a Time	6-32
Example 6-40.	PMOVSX/PMOVZX Work-around to Avoid False Dependency	6-34
Example 6-41.	Table Look-up Operations in C Code	6-34
Example 6-42.	Shift Techniques on Non-Vectorizable Table Look-up	6-35
Example 6-43.	PEXTRD Techniques on Non-Vectorizable Table Look-up	6-36
Example 6-44.	Pseudo-Code Flow of AES Counter Mode Operation	6-37
Example 6-45.	AES128-CTR Implementation with Eight Block in Parallel	6-38
Example 6-46.	AES128 Key Expansion	6-45
Example 6-47.	Compress 32-bit Integers into 5-bit Buckets	6-48
Example 6-48.	Decompression of a Stream of 5-bit Integers into 32-bit Elements	6-50
Example 7-1.	Pseudocode for Horizontal (xyz, AoS) Computation	7-4
Example 7-2.	Pseudocode for Vertical (xxxx, yyyy, zzzz, SoA) Computation	7-5
Example 7-3.	Swizzling Data Using SHUFPS, MOVLHPS, MOVHLPS	7-5
Example 7-4.	Swizzling Data Using UNPCKxxx Instructions	7-6
Example 7-5.	Deswizzling Single-Precision SIMD Data	7-7
Example 7-6.	Deswizzling Data Using SIMD Integer Instructions	7-8
Example 7-7.	Horizontal Add Using MOVHLPS/MOVLHPS	7-9
Example 7-8.	Horizontal Add Using Intrinsics with MOVHLPS/MOVLHPS	7-10
Example 7-9.	Multiplication of Two Pairs of Single-Precision Complex Number	7-12
Example 7-10.	Division of Two Pairs of Single-Precision Complex Numbers	7-12
Example 7-11.	Double-Precision Complex Multiplication of Two Pairs	7-13
Example 7-12.	Double-Precision Complex Multiplication Using Scalar SSE2	7-13
Example 7-13.	Dot Product of Vector Length 4 Using SSE/SSE2	7-14
Example 7-14.	Dot Product of Vector Length 4 Using SSE3	7-15
Example 7-15.	Dot Product of Vector Length 4 Using SSE4.1	7-15
Example 7-16.	Unrolled Implementation of Four Dot Products	7-15
Example 7-17.	Normalization of an Array of Vectors	7-16
Example 7-18.	Normalize (x, y, z) Components of an Array of Vectors Using SSE2	7-17
Example 7-19.	Normalize (x, y, z) Components of an Array of Vectors Using SSE4.1	7-18
Example 7-20.	Data Organization in Memory for AOS Vector-Matrix Multiplication	7-19
Example 7-21.	AOS Vector-Matrix Multiplication with HADDPS	7-19
Example 7-22.	AOS Vector-Matrix Multiplication with DPPS	7-20
Example 7-23.	Data Organization in Memory for SOA Vector-Matrix Multiplication	7-21
Example 7-24.	Vector-Matrix Multiplication with Native SOA Data Layout	7-22
Example 8-1.	VPDPBUSD Implementation	8-3
Example 8-2.	Quantization of Activations	8-5
Example 8-3.	Direct Convolution	8-10
Example 8-4.	Convolution for Layers with Low OFM Count	8-14
Example 8-5.	Basic PostConv	8-16
Example 8-6.	Uint8 Residual Input	8-17
Example 8-7.	8x8 Average Pooling with Stride 1 of 8x8 Layers	8-18
Example 8-8.	Unfused Vectorized Pooling	8-18

Example 8-9.	Caffe Scalar Code for Pixel Shuffler	8-20
Example 8-10.	Computing Output Offset for Fused Pixel Shuffler	8-21
Example 8-11.	Sigmoid Approximation with Minimax Polynomials	8-22
Example 8-12.	Sigmoid Approximation with scalef	8-23
Example 8-13.	Pseudocode for Finding Top K	8-25
Example 9-1.	Pseudo-code Using CLFLUSH	9-9
Example 9-2.	Flushing Cache Lines Using CLFLUSH or CLFLUSHOPT	9-12
Example 9-3.	Populating an Array for Circular Pointer Chasing with Constant Stride	9-13
Example 9-4.	Prefetch Scheduling Distance	9-16
Example 9-5.	Using Prefetch Concatenation	9-17
Example 9-6.	Concatenation and Unrolling the Last Iteration of Inner Loop	9-17
Example 9-8.	Data Access of a 3D Geometry Engine with Strip-mining	9-22
Example 9-7.	Data Access of a 3D Geometry Engine without Strip-mining	9-22
Example 9-9.	Using HW Prefetch to Improve Read-Once Memory Traffic	9-23
Example 9-10.	Basic Algorithm of a Simple Memory Copy	9-27
Example 9-11.	A Memory Copy Routine Using Software Prefetch	9-28
Example 9-12.	Memory Copy Using Hardware Prefetch and Bus Segmentation	9-29
Example 11-1.	Serial Execution of Producer and Consumer Work Items	11-5
Example 11-2.	Basic Structure of Implementing Producer Consumer Threads	11-6
Example 11-3.	Thread Function for an Interlaced Producer Consumer Model	11-7
Example 11-4.	Spin-wait Loop and PAUSE Instructions	11-12
Example 11-5.	Coding Pitfall using Spin Wait Loop	11-14
Example 11-6.	Placement of Synchronization and Regular Variables	11-15
Example 11-7.	Declaring Synchronization Variables without Sharing a Cache Line	11-16
Example 11-8.	Batched Implementation of the Producer Consumer Threads	11-20
Example 11-9.	Parallel Memory Initialization Technique Using OpenMP and NUMA	11-24
Example 13-1.	Compute 64-bit Quotient and Remainder with 64-bit Divisor	13-3
Example 13-2.	Quotient and Remainder of 128-bit Dividend with 64-bit Divisor	13-4
Example 14-1.	A Hash Function Examples	14-4
Example 14-2.	Hash Function Using CRC32	14-4
Example 14-3.	Strlen() Using General-Purpose Instructions	14-6
Example 14-4.	Sub-optimal PCMPISTRI Implementation of EOS handling	14-8
Example 14-5.	Strlen() Using PCMPISTRI without Loop-Carry Dependency	14-8
Example 14-6.	WordCnt() Using C and Byte-Scanning Technique	14-9
Example 14-7.	WordCnt() Using PCMPISTRM	14-10
Example 14-8.	KMP Substring Search in C	14-12
Example 14-9.	Brute-Force Substring Search Using PCMPISTRI Intrinsic	14-13
Example 14-10.	Substring Search Using PCMPISTRI and KMP Overlap Table	14-15
Example 14-11.	Equivalent Strtok_s() Using PCMPISTRI Intrinsic	14-19
Example 14-12.	Equivalent Strupr() Using PCMPISTRM Intrinsic	14-21
Example 14-13.	UTF16 VerStrlen() Using C and Table Lookup Technique	14-22
Example 14-14.	Assembly Listings of UTF16 VerStrlen() Using PCMPISTRI	14-23
Example 14-15.	Intrinsic Listings of UTF16 VerStrlen() Using PCMPISTRI	14-25
Example 14-16.	Replacement String Library Strcmp Using SSE4.2	14-27
Example 14-17.	High-level flow of Character Subset Validation for String Conversion	14-29
Example 14-18.	Intrinsic Listings of atol() Replacement Using PCMPISTRI	14-29
Example 14-19.	Auxiliary Routines and Data Constants Used in sse4i_atol() listing	14-31
Example 14-20.	Conversion of 64-bit Integer to ASCII	14-34
Example 14-21.	Conversion of 64-bit Integer to ASCII without Integer Division	14-35
Example 14-22.	Conversion of 64-bit Integer to ASCII Using SSE4	14-37
Example 14-23.	Conversion of 64-bit Integer to Wide Character String Using SSE4	14-43
Example 14-24.	MULX and Carry Chain in Large Integer Numeric	14-48
Example 14-25.	Building-block Macro Used in Binary Decimal Floating-point Operations	14-49
Example 15-1.	Cartesian Coordinate Transformation with Intrinsics	15-3
Example 15-2.	Cartesian Coordinate Transformation with Assembly	15-4
Example 15-3.	Direct Polynomial Calculation	15-6
Example 15-4.	Function Calls and AVX/SSE transitions	15-10
Example 15-5.	AoS to SoA Conversion of Complex Numbers in C Code	15-12
Example 15-6.	AoS to SoA Conversion of Complex Numbers Using AVX	15-13

Example 15-7.	Register Overlap Method for Median of 3 Numbers	15-15
Example 15-8.	Data Gather - AVX versus Scalar Code	15-17
Example 15-9.	Scatter Operation Using AVX	15-18
Example 15-10.	SAXPY using Intel AVX	15-20
Example 15-11.	Using 16-Byte Memory Operations for Unaligned 32-Byte Memory Operation	15-21
Example 15-12.	SAXPY Implementations for Unaligned Data Addresses	15-21
Example 15-13.	Loop with Conditional Expression	15-25
Example 15-14.	Handling Loop Conditional with VMASKMOV	15-25
Example 15-15.	Three-Tap Filter in C Code	15-26
Example 15-16.	Three-Tap Filter with 128-bit Mixed Integer and FP SIMD	15-26
Example 15-17.	256-bit AVX Three-Tap Filter Code with VSHUFPS	15-27
Example 15-18.	Three-Tap Filter Code with Mixed 256-bit AVX and 128-bit AVX Code	15-28
Example 15-19.	8x8 Matrix Transpose - Replace Shuffles with Blends	15-30
Example 15-20.	8x8 Matrix Transpose Using VINSERTPS	15-33
Example 15-21.	Port 5 versus Load Port Shuffles	15-35
Example 15-22.	Divide Using DIVPS for 24-bit Accuracy	15-37
Example 15-23.	Divide Using RCPPS 11-bit Approximation	15-38
Example 15-24.	Divide Using RCPPS and Newton-Raphson Iteration	15-38
Example 15-25.	Reciprocal Square Root Using DIVPS+SQRTPS for 24-bit Accuracy	15-39
Example 15-26.	Reciprocal Square Root Using RSQRTPS 11-bit Approximation	15-39
Example 15-27.	Reciprocal Square Root Using RSQRTPS and Newton-Raphson Iteration	15-40
Example 15-28.	Square Root Using SQRTPS for 24-bit Accuracy	15-41
Example 15-29.	Square Root Using RSQRTPS 11-bit Approximation	15-41
Example 15-30.	Square Root Using RSQRTPS and One Taylor Series Expansion	15-42
Example 15-31.	Array Sub Sums Algorithm	15-44
Example 15-32.	Single-Precision to Half-Precision Conversion	15-45
Example 15-33.	Half-Precision to Single-Precision Conversion	15-46
Example 15-34.	Performance Comparison of Median3 using Half-Precision vs. Single-Precision	15-47
Example 15-35.	FP Mul/FP Add Versus FMA	15-48
Example 15-36.	Unrolling to Hide Dependent FP Add Latency	15-49
Example 15-37.	FP Mul/FP Add Versus FMA	15-50
Example 15-38.	Macros for Separable KLT Intra-block Transformation Using AVX2	15-51
Example 15-39.	Separable KLT Intra-block Transformation Using AVX2	15-53
Example 15-40.	Macros for Parallel Moduli/Remainder Calculation	15-59
Example 15-41.	Signed 64-bit Integer Conversion Utility	15-60
Example 15-42.	Unsigned 63-bit Integer Conversion Utility	15-61
Example 15-43.	Access Patterns Favoring Non-VGATHER Techniques	15-65
Example 15-44.	Access Patterns Likely to Favor VGATHER Techniques	15-66
Example 15-45.	Software AVX Sequence Equivalent to Full-Mask VPGATHERD	15-67
Example 15-46.	AOS to SOA Transformation Alternatives	15-69
Example 15-47.	Non-Strided AOS to SOA	15-70
Example 15-48.	Conversion to Throughput-Reduced MMX sequence to AVX2 Alternative	15-72
Example 16-1.	Reduce Data Conflict with Conditional Updates	16-6
Example 16-2.	Transition from Non-Elided Execution without Aborting	16-10
Example 16-3.	Exemplary Wrapper Using RTM for Lock/Unlock Primitives	16-12
Example 16-4.	Spin Lock Example Using HLE in GCC 4.8 and Later	16-14
Example 16-5.	Spin Lock Example Using HLE in Intel and Microsoft Compiler Intrinsic	16-14
Example 16-6.	A Meta Lock Example	16-16
Example 16-7.	A Meta Lock Example Using RTM	16-17
Example 16-8.	HLE-enabled Lock-Acquire/ Lock-Release Sequence	16-18
Example 16-9.	A Spin Wait Example Using HLE	16-19
Example 16-10.	A Conceptual Example of Intermixed HLE and RTM	16-20
Example 16-11.	Emulated RTM intrinsic for Older GCC compilers	16-27
Example 16-12.	C++ Example of HLE Intrinsic	16-29
Example 16-13.	Emulated HLE Intrinsic with Older GCC compiler	16-29
Example 16-14.	HLE Intrinsic Supported by Intel and Microsoft Compilers	16-30
Example 17-1.	Unoptimized Sleep Loop	17-14
Example 17-2.	Power Consumption Friendly Sleep Loop Using PAUSE	17-14
Example 18-1.	Cartesian Coordinate System Rotation with Intrinsics	18-3

Example 18-2.	Cartesian Coordinate System Rotation with Assembly	18-5
Example 18-3.	Masking with Intrinsics	18-9
Example 18-4.	Masking with Assembly	18-9
Example 18-5.	Masking Example	18-11
Example 18-6.	Masking vs. Blending Example 1	18-12
Example 18-7.	Masking vs. Blending Example 2	18-13
Example 18-8.	Multiple Condition Execution	18-14
Example 18-9.	Peeling and Remainder Masking	18-15
Example 18-10.	Comparing Intel® AVX-512 Data Compress with Other Alternatives	18-19
Example 18-11.	Comparing Intel® AVX-512 Data Expand Operation with Other Alternatives	18-24
Example 18-12.	Comparing Ternary Logic to Other Alternatives	18-26
Example 18-13.	Matrix Transpose Alternatives	18-31
Example 18-14.	Broadcast Executed on Load Ports Alternatives	18-32
Example 18-15.	16-bit Broadcast Executed on Port 5	18-33
Example 18-16.	Embedded vs Non-embedded Rounding	18-34
Example 18-17.	Scatter	18-36
Example 18-18.	QWORD Example, Intel® AVX2 vs. Intel® AVX-512	18-39
Example 18-19.	Scatter Implementation Alternatives	18-50
Example 18-20.	Scalar vs. Vector Update Using AVX-512CD	18-53
Example 18-21.	Improvement with VPERMB Implementation	18-55
Example 18-22.	Improvement with VPERMI2B Implementation	18-57
Example 18-23.	Improvement with VPMULTISHIFTQB Implementation	18-59
Example 18-24.	256-bit Code vs. 256-bit Code Mixed with 512-bit Code	18-63
Example 18-25.	Identifying One or Two FMA Units in a Processor Based on Skylake Microarchitecture	18-64
Example 18-26.	Gather to Shuffle in Strided Loads Example	18-68
Example 18-27.	Gather to Shuffle in Strided Stores Example	18-69
Example 18-28.	Gather to Shuffle in Adjacent Loads Example	18-71
Example 18-29.	Data Alignment	18-72
Example 18-30.	Vectorized 32-bit Float Division	18-78
Example 18-31.	Reciprocal Square Root	18-79
Example 18-32.	Square Root	18-80
Example 18-33.	Dividing Packed Doubles	18-81
Example 18-34.	Reciprocal Square Root of Doubles	18-82
Example 18-35.	Square Root of Packed Doubles	18-83
Example 19-1.	Function for Converting from a Complex-Valued Mask To a Real-Valued Mask by Duplicating Adjacent Bits	19-8
Example 19-2.	Function for Converting from a Real-Valued Mask to a Complex-Valued Mask By AND-Combining Adjacent Bits	19-9
Example 19-3.	Function for Converting from a Real-Valued Mask To a Complex-Valued Mask By OR-Combining Adjacent Bits	19-9
Example 19-4.	Function to Implement the 16-Bit Compress Operation on FP16 Vector Elements	19-17
Example 19-5.	Function That Performs Fast Floating-Point Minimum Using Integer Instructions	19-19
Example 20-1.	Pseudo-code for the Tilezero, TileLoad, and TileStore Instructions	20-6
Example 20-2.	B Matrix Re-layout Procedure	20-6
Example 20-3.	Common Defines	20-8
Example 20-4.	Reference GEMM Implementation	20-9
Example 20-5.	K-dimension Loop as Innermost Loop—A highly inefficient approach	20-10
Example 20-6.	Innermost Loop Tile Pre-loading	20-11
Example 20-7.	Switched Order of M_ACC and N_ACC Loops	20-11
Example 20-8.	Optimized GEMM implementation	20-12
Example 20-9.	Dimension of matrices, data types and tile sizes	20-13
Example 20-10.	Optimized GEMM Assembly Language Implementation	20-14
Example 20-11.	Activations Layout Procedure	20-15
Example 20-12.	Weights Re-Layout Procedure	20-16
Example 20-13.	Common Defines for Convolution	20-19
Example 20-14.	Optimized direct convolution implementation	20-20
Example 20-15.	Additional Defines for Convolution with Cache Blocking	20-21
Example 20-16.	Optimized Convolution Implementation with Cache Blocking	20-22
Example 20-17.	Optimized Convolution Implementation with Cache Blocking	20-30

Example 20-18.	Example of a Short GEMM Fused and Pipelined with Quantization and ReLU	20-32
Example 20-19.	The conversion code for two blocks of sixteen cache lines of 32-bit floats converted to a single block of sixteen cache lines of 16-bit bfloats	20-36
Example 20-20.	Using Unsigned Saturation	20-37
Example 20-21.	Prefetching Rows to the DCU	20-40
Example 20-22.	BF16 Matrix Transpose (32x8 to 8x32)	20-42
Example 20-23.	BF16 VNNI to VNNI Transpose (8x8 to 2x32)	20-47
Example 20-24.	BF16 Flat to VNNI Transpose (16x8 to 4x32)	20-50
Example 20-25.	BF16 Flat-to-VNNI Re-Layout	20-52
Example 20-26.	GEMM Parallelized with omp Parallel for with Collapse	20-56
Example 20-27.	Byte Decompression code with Intel® AVX-512 Intrinsics	20-58
Example 20-28.	The Parameter m, n, k Identifies the Shape of the Tile	20-60
Example 20-29.	Intel® AMX Intrinsics header file	20-61
Example 20-30.	Intel® AMX Intrinsics usage	20-64
Example 20-31.	Compiler-generated assembly-level code out of example 20-30 Intrinsics code	20-65
Example 20-32.	Compiler-generated assembly-level code where tile register save/restore is optimized away	20-66
Example 21-1.	Legacy Intel® AES-NI vs. Vector AES	21-1
Example 21-2.	SM4 GFNI Encryption Round Example	21-3
Example 23-1.	Gather Comparison Between AVX-512F and AVX2	23-8
Example 23-2.	Gather Comparison Between AVX-512F and Previous Generation Equivalent	23-8
Example 23-3.	Using VRCP28SS for 32-bit Floating-Point Division	23-9
Example 23-4.	Replace VCOMIS* with VCOMPSS/KORTEST	23-11
Example 23-5.	Using Software Sequence for Horizontal Reduction	23-12
Example 23-6.	Optimized Inner Loop of DGEMM for Knights Landing Microarchitecture	23-13
Example 23-7.	Ordering of Memory Instruction for MEC	23-18
Example F-1.	Instruction Pairing and Alignment to Optimize Decode Throughput on Intel Atom® Microarchitecture	F-4
Example F-2.	Alternative to Prevent AGU and Execution Unit Dependency	F-6
Example F-3.	Pipelining Instruction Execution in Integer Computation	F-7
Example F-4.	Memory Copy of 64-byte	F-11
Example F-5.	Examples of Dependent Multiply and Add Computation	F-12
Example F-6.	Instruction Pointer Query Techniques	F-13
Example F-7.	Unrolled Loop Executes In-Order Due to Multiply-Store Port Conflict	F-33
Example F-8.	Grouping Store Instructions Eliminates Bubbles and Improves IPC	F-33

FIGURES

Figure 2-1.	Processor Core Pipeline Functionality of the Golden Cove Microarchitecture	2-8
Figure 2-2.	Processor Front End of the Golden Cove Microarchitecture.	2-9
Figure 2-3.	Processor Core Pipeline Functionality of the Ice Lake Client Microarchitecture	2-14
Figure 2-4.	Processor Core Pipeline Functionality of the Skylake Server Microarchitecture	2-22
Figure 2-5.	Broadwell Microarchitecture and Skylake Server Microarchitecture Cache Structures	2-24
Figure 2-6.	Mixed Workloads	2-26
Figure 2-7.	LINPACK Performance	2-27
Figure 2-8.	CPU Core Pipeline Functionality of the Skylake Client Microarchitecture.	2-28
Figure 2-9.	Hyper-Threading Technology on an SMP	2-35
Figure 2-10.	Typical SIMD Operations	2-37
Figure 2-11.	SIMD Instruction Register Usage.	2-38
Figure 3-1.	Generic Program Flow of Partially Vectorized Code	3-35
Figure 3-2.	Memcpy Performance Comparison for Lengths up to 2KB.	3-62
Figure 3-3.	MariaDB - CHA % Cycles Fast Asserted.	3-73
Figure 3-4.	Identifying >2GB Branches	3-75
Figure 4-1.	Processor Core Pipeline Functionality of the Gracemont Microarchitecture.	4-2
Figure 4-2.	Front-End Pipeline Functionality of the Gracemont Microarchitecture.	4-3
Figure 4-3.	Execution Pipeline Functionality of the Gracemont Microarchitecture.	4-6
Figure 4-4.	Processor Core Pipeline Functionality of the Tremont Microarchitecture	4-11
Figure 5-1.	General Procedural Flow of Application Detection of AVX.	5-6
Figure 5-2.	General Procedural Flow of Application Detection of Float-16	5-8
Figure 5-3.	Converting to Streaming SIMD Extensions Chart.	5-11
Figure 5-4.	Hand-Coded Assembly and High-Level Compiler Performance Trade-offs	5-13
Figure 5-5.	Loop Blocking Access Pattern	5-26
Figure 6-1.	PACKSSDW mm, mm/mm64 Instruction	6-6
Figure 6-2.	Interleaved Pack with Saturation	6-7
Figure 6-3.	Result of Non-Interleaved Unpack Low in MMO	6-8
Figure 6-4.	Result of Non-Interleaved Unpack High in MM1	6-8
Figure 6-5.	PEXTRW Instruction	6-9
Figure 6-6.	PINSRW Instruction	6-10
Figure 6-7.	PMOVSMB Instruction	6-12
Figure 6-8.	Data Alignment of Loads and Stores in Reverse Memory Copy	6-31
Figure 6-9.	A Technique to Avoid Cacheline Split Loads in Reverse Memory Copy Using Two Aligned Loads.	6-32
Figure 7-1.	Homogeneous Operation on Parallel Data Elements.	7-3
Figure 7-2.	Horizontal Computation Model.	7-3
Figure 7-3.	Dot Product Operation	7-4
Figure 7-4.	Horizontal Add Using MOVHLPS/MOVLHPS.	7-9
Figure 7-5.	Asymmetric Arithmetic Operation of the SSE3 Instruction	7-11
Figure 7-6.	Horizontal Arithmetic Operation of the SSE3 Instruction HADDPD	7-11
Figure 8-1.	Matrix Layout, Inputs and Outputs	8-7
Figure 8-2.	Transformed Weights	8-8
Figure 8-3.	Convolution Operation	8-8
Figure 8-4.	Matrix Multiplications and Summations.	8-8
Figure 8-5.	3-Tier Flexible 2D Blocking	8-9
Figure 8-6.	3-Tier Flexible 2D Blocking Loops.	8-10
Figure 8-7.	Standard vs Optimized vs. Low OFM Optimized Data Layouts.	8-13
Figure 8-8.	Dynamic Batch Size	8-24
Figure 8-9.	Find Top 16 Values in Some Input	8-24
Figure 9-1.	CLFLUSHOPT versus CLFLUSH In SkyLake Microarchitecture	9-11
Figure 9-2.	Effective Latency Reduction as a Function of Access Stride.	9-14
Figure 9-3.	Memory Access Latency and Execution Without Prefetch	9-14
Figure 9-4.	Memory Access Latency and Execution With Prefetch	9-15
Figure 9-5.	Prefetch and Loop Unrolling	9-18
Figure 9-6.	Memory Access Latency and Execution With Prefetch	9-18
Figure 9-7.	Spread Prefetch Instructions	9-19

Figure 9-8.	Cache Blocking – Temporally Adjacent and Non-adjacent Passes.....	9-20
Figure 9-9.	Examples of Prefetch and Strip-mining for Temporally Adjacent and Non-Adjacent Passes Loops	9-21
Figure 9-10.	Single-Pass Vs. Multi-Pass 3D Geometry Engines	9-25
Figure 10-1.	Example of SNC Configuration.....	10-1
Figure 10-2.	NUMA Disabled	10-5
Figure 10-3.	SNC Off	10-6
Figure 10-4.	SNC On.....	10-7
Figure 10-5.	Domain Example with One MPI Process Per Domain.....	10-8
Figure 11-1.	Amdahl's Law and MP Speed-up	11-2
Figure 11-2.	Single-threaded Execution of Producer-consumer Threading Model.....	11-5
Figure 11-3.	Execution of Producer-consumer Threading Model on a Multicore Processor	11-5
Figure 11-4.	Interlaced Variation of the Producer Consumer Model.....	11-6
Figure 11-5.	Batched Approach of Producer Consumer Model.....	11-20
Figure 12-1.	In App Direct Mode, Data on the Intel® Optane™ DC Persistent Memory Module is Accessed Directly with Loads and Stores	12-2
Figure 12-2.	Decision Flow for Determining When to Use Intel® Optane™ DC Persistent Memory Module vs. DRAM.....	12-3
Figure 12-3.	Loaded Latency Curves for One Intel® Optane™ DC Persistent Memory Module DIMM: Sequential Traffic (Left) and Random Traffic (Right)	12-5
Figure 12-4.	Number of Threads vs. Bandwidth	12-6
Figure 12-5.	Combining with Two Cores	12-6
Figure 12-6.	Combining with Four Cores	12-7
Figure 12-7.	Combining with Eight Cores	12-8
Figure 12-8.	PMDK vs. MSYNC Flushing Times.....	12-9
Figure 12-9.	Bandwidth vs. Power Consumption	12-10
Figure 12-10.	Read-Write Equivalence for Intel® Optane™ DC Persistent Memory Module DIMMs within Different Power Budgets	12-11
Figure 12-11.	Bandwidth Available to Software when There is No Locality at 256B Granularity	12-12
Figure 14-1.	SSE4.2 String/Text Instruction Immediate Operand Control	14-2
Figure 14-2.	Retrace Inefficiency of Byte-Granular, Brute-Force Search	14-12
Figure 14-3.	SSE4.2 Speedup of SubString Searches	14-18
Figure 14-4.	Compute Four Remainders of Unsigned Short Integer in Parallel.....	14-37
Figure 15-1.	AVX-SSE Transitions in the Broadwell, and Prior Generation Microarchitectures.....	15-8
Figure 15-2.	AVX-SSE Transitions in the Skylake Microarchitecture	15-8
Figure 15-3.	4x4 Image Block Transformation.....	15-51
Figure 15-4.	Throughput Comparison of Gather Instructions.....	15-67
Figure 15-5.	Comparison of HW GATHER Versus Software Sequence in Skylake Microarchitecture.....	15-68
Figure 17-1.	Performance History and State Transitions	17-2
Figure 17-2.	Active Time Versus Halted Time of a Processor	17-3
Figure 17-3.	Application of C-states to Idle Time	17-4
Figure 17-4.	Profiles of Coarse Task Scheduling and Power Consumption	17-9
Figure 17-5.	Thread Migration in a Multicore Processor.....	17-11
Figure 17-6.	Progression to Deeper Sleep	17-11
Figure 17-7.	Energy Saving due to Performance Optimization	17-13
Figure 17-8.	Energy Saving due to Vectorization.....	17-13
Figure 17-9.	Energy Saving Comparison of Synchronization Primitives	17-16
Figure 17-10.	Power Saving Comparison of Power-Source-Aware Frame Rate Configurations.....	17-17
Figure 18-1.	Intel® AVX-512 Extensions Supported by Skylake Server Microarchitecture and Knights Landing Microarchitecture.....	18-1
Figure 18-2.	Cartesian Rotation.....	18-2
Figure 18-3.	Data Forwarding Cases.....	18-16

Figure 18-4.	Data Compress Operation	18-18
Figure 18-5.	Data Expand Operation	18-23
Figure 18-6.	Ternary Logic Example 1 Truth Table	18-25
Figure 18-7.	Ternary Logic Example 2 Truth Table	18-28
Figure 18-8.	VPERMI2PS Instruction Operation	18-29
Figure 18-9.	VSCATTERDPD Instruction Operation	18-35
Figure 18-10.	VPCONFLICTD Instruction Execution	18-48
Figure 18-11.	VPCONFLICTD Merging Process	18-49
Figure 18-12.	VPCONFLICTD Permute Control	18-49
Figure 18-13.	VPCONFLICTD ZMM2 Result	18-51
Figure 18-14.	Sparse Vector Example	18-51
Figure 18-15.	VPERMB Instruction Operation	18-54
Figure 18-16.	VPERMI2B Instruction Operation	18-55
Figure 18-17.	VPERMT2B Instruction Operation	18-56
Figure 18-18.	VPMULTISHIFTQB Instruction Operation	18-58
Figure 18-19.	Fast Bypass When All Sources Come from FMA Unit	18-61
Figure 18-20.	Mixing Intel AVX Instructions or Intel AVX-512 Instructions with Intel SSE Instructions	18-62
Figure 19-1.	Layout of a 128-Bit Register Representing Four Complex FP16 (CFP16) Values	19-4
Figure 19-2.	Illustration of a Zero-Masked FP16 Add On Two 128-Bit Vectors	19-6
Figure 19-3.	Illustration of a Masked Complex Multiplication	19-7
Figure 19-4.	Illustration of Using a Real-Valued FP16 Vector Operation for Implementing a Masked Complex Addition	19-7
Figure 19-5.	Comparison Operation Between Two Complex-Valued Vectors. The mask bits are generated using a real-valued comparison, then adjacent bits combined using AND	19-8
Figure 19-6.	Bit Layout of Three Types of Floating-Point Formats	19-10
Figure 19-7.	Landmark Numbers on the Real-Valued FP16 Axis	19-11
Figure 19-8.	Heat-map Showing Relative ULP Error for Different Combinations of Divisor and Dividend Value Ranges	19-16
Figure 20-1.	Matrix Notation	20-4
Figure 20-2.	Intel® AMX Multiplication with Max-sized int8 Tiles	20-5
Figure 20-3.	Re-layout of 64x16 int8 B Matrix	20-7
Figure 20-4.	Re-layout of 32x16 bfloat16 B Matrix	20-7
Figure 20-5.	Activations layout	20-16
Figure 20-6.	Weights Re-Layout	20-17
Figure 20-7.	Convolution - Matrix Multiplication and Summation Equivalence	20-17
Figure 20-8.	Matrix-Like Multiplications Part of a Convolution	20-18
Figure 20-9.	Batching Execution Using Six Layers with Four Instances Per Thread	20-24
Figure 20-10.	An Example of a Convolution Elements interacting with weight element $k_h, k_w=0,0$ are highlighted	20-27
Figure 20-11.	An Example of a Convolution with Large Tiles. Elements going into each tile are highlighted differently	20-28
Figure 20-12.	Please provide Figure Description	20-34
Figure 20-13.	A Conversion Flow of 32-bit Integers to 8-bit Integers	20-36
Figure 20-14.	Trivial Deep Learning Topology with Naive Buffer Allocation	20-37
Figure 20-15.	Minimal Memory Footprint Buffer Allocation Scheme for the Trivial Deep Learning Topology	20-38
Figure 20-16.	Loading 32 Quarter-Cache Lines into 8 ZMM Registers	20-45
Figure 20-17.	The Implementation of loading eight quarter-cache lines into two ZMM registers	20-48
Figure 20-18.	Flat-to-VNNI transpose of WORDs is equivalent to Flat-to-Flat transpose of DWORDs	20-48
Figure 20-19.	BF16 Flat-to-VNNI Transpose	20-51
Figure 20-20.	GEMM Data Partitioning Between Three Cores in a Layer Partitioned by the M Dimension	20-54
Figure 20-21.	GEMM Data Partitioning Between Three Cores in a Layer Partitioned by the N-Dimension	20-54

Figure 20-22.	GEMM Data Partitioning Between Three Cores in a Layer Partitioned by the K Dimension	20-55
Figure 20-23.	A recommendation system multi-threading model	20-57
Figure 20-24.	Data Expand Operation	20-59
Figure 23-1.	Tile-Mesh Topology of the Knights Landing Microarchitecture	23-1
Figure 23-2.	Processor Core Pipeline Functionality of the Knights Landing Microarchitecture	23-2
Figure B-1.	General TMA Hierarchy for Out-of-Order Microarchitectures	B-2
Figure B-2.	TMA's Top Level Drill Down Flowchart	B-3
Figure B-3.	TMA Hierarchy and Precise Events in Skylake	B-8
Figure B-4.	System Topology Supported by Intel® Xeon® Processor 5500 Series	B-15
Figure B-5.	PMU Specific Event Logic Within the Pipeline	B-17
Figure B-6.	LBR Records and Basic Blocks	B-28
Figure B-7.	Using LBR Records to Rectify Skewed Sample Distribution	B-28
Figure B-8.	RdData Request after LLC Miss to Local Home (Clean Rsp)	B-39
Figure B-9.	RdData Request after LLC Miss to Remote Home (Clean Rsp)	B-39
Figure B-11.	RdData Request after LLC Miss to Local Home (Hitm Response)	B-40
Figure B-10.	RdData Request after LLC Miss to Remote Home (Hitm Response)	B-40
Figure B-12.	RdData Request after LLC Miss to Local Home (Hit Response)	B-41
Figure B-13.	RdInvOwn Request after LLC Miss to Remote Home (Clean Res)	B-41
Figure B-15.	RdInvOwn Request after LLC Miss to Local Home (Hit Res)	B-42
Figure B-14.	RdInvOwn Request after LLC Miss to Remote Home (Hitm Res)	B-42
Figure B-16.	Performance Events Drill-Down and Software Tuning Feedback Loop	B-61
Figure C-1.	ITLB Miss Stalls in Language Runtimes on Intel® Xeon® 8180 Processor	C-1
Figure C-2.	ITLB and ITLB 4K MPKI Across Runtime Workloads	C-4
Figure C-3.	measure-perf-metric.sh Tool Usage for Process ID 69772 for 30 Seconds	C-5
Figure C-4.	Using measure-perf-metric.sh with -r to Determine Where TLB Misses are Coming From	C-6
Figure C-5.	Commands for Checking Linux* Distribution for THP	C-7
Figure C-6.	API Calls Provided by the Intel Reference Implementation	C-8
Figure C-7.	perf Output Will Not Have the Proper Symbols After Large Page Mapping	C-10
Figure C-8.	Using Perf Record with -e frontend_retired.itlb_miss to Determine ITLB Misses and Running Perf Script to Obtain Data for Importing into FlameScope	C-13
Figure C-9.	Using FlameScope to Visualize the ITLB Misses Heatmap from the WebTooling Workload	C-14
Figure C-10.	Using FlameScope to Visualize the ITLB Misses Heatmap from the WebTooling Workload when Run with Large Pages	C-14
Figure C-11.	Visualizing ITLB Miss Trends for "Built-in" Functions from the Ghost.js Workload	C-15
Figure C-12.	Visualizing ITLB Miss Trends for "Built-in" Functions from the Ghost.js Workload When Run with Large Pages	C-15
Figure E-1.	CPU Core Pipeline Functionality of the Haswell Microarchitecture	E-1
Figure E-2.	Four Core System Integration of the Haswell Microarchitecture	E-2
Figure E-3.	An Example of the Haswell-E Microarchitecture Supporting 12 Processor Cores	E-7
Figure E-4.	Sandy Bridge Microarchitecture Pipeline Functionality	E-9
Figure E-5.	Intel Core Microarchitecture Pipeline Functionality	E-28
Figure E-6.	Execution Core of Intel Core Microarchitecture	E-34
Figure E-7.	Store-Forwarding Enhancements in Enhanced Intel Core Microarchitecture	E-37
Figure E-8.	Intel Advanced Smart Cache Architecture	E-38
Figure E-9.	Nehalem Microarchitecture Pipeline Functionality	E-41
Figure E-10.	Front End of Nehalem Microarchitecture	E-42
Figure E-11.	Store-Forwarding Scenarios of 16-Byte Store Operations	E-47
Figure E-12.	Store-Forwarding Enhancement in Nehalem Microarchitecture	E-48
Figure F-1.	Intel Atom® Microarchitecture Pipeline	F-2
Figure F-2.	Silvermont Microarchitecture Pipeline	F-20
Figure F-3.	CPU Core Pipeline Functionality of the Goldmont Microarchitecture	F-24
Figure F-4.	CPU Core Pipeline Functionality of the Goldmont Plus Microarchitecture	F-27

CONTENTS

PAGE

TABLES

Table 2-2.	Golden Cove Microarchitecture Execution Units and Representative Instructions	2-10
Table 2-1.	Dispatch Port and Execution Stacks of the Golden Cove Microarchitecture	2-10
Table 2-3.	Bypass Delay Between Producer and Consumer Micro-ops	2-11
Table 2-4.	Dispatch Port and Execution Stacks of the Ice Lake Client Microarchitecture ...	2-16
Table 2-5.	Ice Lake Client Microarchitecture Execution Units and Representative Instructions	2-16
Table 2-6.	Bypass Delay Between Producer and Consumer Micro-ops	2-17
Table 2-7.	Cache Parameters of the Ice Lake Client Microarchitecture	2-18
Table 2-8.	TLB Parameters of the Ice Lake Client Microarchitecture	2-18
Table 2-9.	Cache Comparison Between Skylake Microarchitecture and Broadwell Microarchitecture	2-23
Table 2-10.	Maximum Intel® Turbo Boost Technology Core Frequency Levels	2-25
Table 2-11.	Dispatch Port and Execution Stacks of the Skylake Client Microarchitecture ...	2-30
Table 2-12.	Skylake Client Microarchitecture Execution Units and Representative Instructions	2-30
Table 2-13.	Bypass Delay Between Producer and Consumer Micro-ops	2-31
Table 2-14.	Cache Parameters of the Skylake Client Microarchitecture	2-32
Table 2-15.	TLB Parameters of the Skylake Client Microarchitecture	2-32
Table 3-1.	Macro-Fusible Instructions in Sandy Bridge Microarchitecture	3-13
Table 3-2.	Macro-Fusible Instructions in Haswell Microarchitecture	3-13
Table 3-3.	Recommended Multi-Byte Sequence of NOP Instruction	3-27
Table 3-4.	Store Forwarding Restrictions of Processors Based on Intel Core Microarchitecture	3-48
Table 3-5.	Relative Performance of Memcpy() Using Enhanced REP MOVSB and STOSB Vs. 128-bit AVX	3-62
Table 3-6.	Effect of Address Misalignment on Memcpy() Performance	3-63
Table 3-7.	Intel Processor CPU RP Device IDs for Processors Optimizing PCIe Performance	3-71
Table 3-8.	Samples: 365K of events 'anon group{cpu/mem-loads-aux/cpu/mem-loads, ldat=128/pp}', Event count (a--r0x): 67900852	3-72
Table 3-9.	Instruction Sequence Mixing VEX and Legacy on Sapphire Rapids and ICX	3-74
Table 4-1.	Paging Cache Parameters of the Gracemont Microarchitecture	4-7
Table 4-2.	Dispatch Port and Execution Stacks of the Tremont Microarchitecture	4-12
Table 4-3.	Cache Parameters of the Tremont Microarchitecture	4-13
Table 6-1.	PSHUF Encoding	6-13
Table 7-1.	SoA Form of Representing Vertices Data	7-4
Table 9-1.	Implementation Details of Prefetch Hint Instructions	9-4
Table 9-2.	Software Prefetching Considerations into Strip-mining Code	9-23
Table 9-3.	Deterministic Cache Parameters Leaf	9-31
Table 11-1.	Properties of Synchronization Objects	11-11
Table 11-2.	Design-Time Resource Management Choices	11-22
Table 11-3.	Microarchitectural Resources Comparisons of HT Implementations	11-25
Table 12-1.	Latencies for Accessing Intel® Optane™ DC Persistent Memory Modules	12-4
Table 12-2.	Bandwidths per DIMM for Intel® Optane™ DC Persistent Memory Modules and DRAM	12-4
Table 14-1.	SSE4.2 String/Text Instructions Compare Operation on N-elements	14-2
Table 14-2.	SSE4.2 String/Text Instructions Unary Transformation on IntRes1	14-3
Table 14-3.	SSE4.2 String/Text Instructions Output Selection Imm[6]	14-3
Table 14-4.	SSE4.2 String/Text Instructions Element-Pair Comparison Definition	14-3
Table 14-5.	SSE4.2 String/Text Instructions Eflags Behavior	14-3
Table 15-1.	Features between 256-bit AVX, 128-bit AVX and Legacy SSE Extensions	15-2
Table 15-2.	State Transitions of Mixing AVX and SSE Code	15-9
Table 15-3.	Approximate Magnitude of AVX-SSE Transition Penalties in Different Microarchitectures	15-9
Table 15-4.	Effect of VZERoupper with Inter-Function Calls Between AVX and SSE Code	15-10

Table 15-5.	Comparison of Numeric Alternatives of Selected Linear Algebra in Skylake Microarchitecture	15-36
Table 15-6.	Single-Precision Divide and Square Root Alternatives	15-36
Table 15-7.	Comparison of AOS to SOA with Strided Access Pattern	15-69
Table 15-8.	Comparison of Indexed AOS to SOA Transformation	15-71
Table 16-1.	RTM Abort Status Definition	16-23
Table 17-1.	ACPI C-State Type Mappings to Processor Specific C-State for Mobile Processors Based on Nehalem Microarchitecture	17-5
Table 17-2.	ACPI C-State Type Mappings to Processor Specific C-State of Sandy Bridge Microarchitecture	17-5
Table 17-3.	C-State Total Processor Exit Latency for Client Systems (Core+ Package Exit Latency) with Slow VR	17-18
Table 17-4.	C-State Total Processor Exit Latency for Client Systems (Core+ Package Exit Latency) with Fast VR	17-18
Table 17-5.	C-State Core-Only Exit Latency for Client Systems with Slow VR	17-19
Table 17-6.	POWER_CTL MSR in Processors Based on Sandy Bridge Microarchitecture	17-19
Table 18-1.	Cache Comparison Between Skylake Server Microarchitecture and Broadwell Microarchitecture	18-14
Table 18-2.	Static Rounding Mode Functions	18-34
Table 18-3.	Vector Quadword Extensions	18-42
Table 18-4.	Scalar Quadword Extensions	18-42
Table 18-5.	Vector Quadword Extensions	18-43
Table 18-6.	Scalar Quadword Extensions	18-43
Table 18-7.	FMA Unit Latency	18-61
Table 18-8.	Data Alignment Effects on SAXPY Performance vs. Speedup Value	18-72
Table 18-9.	Skylake Microarchitecture Recommendations for DIV/SQRT Based Operations (Single Precision)	18-74
Table 18-10.	Skylake Microarchitecture Recommendations for DIV/SQRT Based Operations (Double Precision)	18-74
Table 18-11.	256-bit Intel AVX2 Divide and Square Root Instruction Performance	18-75
Table 18-12.	512-bit Intel AVX-512 Divide and Square Root Instruction Performance	18-75
Table 18-13.	Latency/Throughput of Different Methods of Computing Divide and Square Root on Skylake Microarchitecture for Different Vector Widths, on Single Precision	18-76
Table 18-14.	Latency/Throughput of Different Methods of Computing Divide and Square Root on Skylake Microarchitecture for Different Vector Widths, on Double Precision	18-77
Table 19-1.	Terminology	19-1
Table 19-2.	Supported FP16 Data Types	19-3
Table 19-3.	Example Intrinsic Names	19-4
Table 19-4.	Conjugation Instructions	19-5
Table 19-5.	Useful or Interesting FP16 Numbers	19-11
Table 19-6.	Conjugation Instructions	19-13
Table 19-7.	Conjugation Instructions	19-18
Table 20-1.	Related Links	20-1
Table 20-2.	Intel® AMX Instruction Throughput and Latency	20-3
Table 20-3.	Five loops in the Example 20-4 Code Listing	20-25
Table 20-4.	Accessed Data Sizes	20-25
Table 20-5.	Accessed Data Sizes	20-26
Table 20-6.	20-26
Table 20-7.	Simple partition of work between three threads	20-56
Table 20-8.	Optimized partition of work between three threads	20-56
Table 23-1.	Integer Pipeline Characteristics of the Knights Landing Microarchitecture	23-4
Table 23-2.	Vector Pipeline Characteristics of the Knights Landing Microarchitecture	23-5
Table 23-3.	Characteristics of Caching Resources	23-6
Table 23-4.	Alternatives to MSR0M Instructions	23-10
Table 23-5.	Cycle Cost Building Blocks for Vectorization Estimate for Knights Landing Microarchitecture	23-14
Table A-1.	Recommended Processor Optimization Options	A-2

Table B-1.	Performance Monitoring Taxonomy	B-9
Table B-2.	Cycle Accounting and Micro-ops Flow Recipe.	B-16
Table B-3.	CMask/Inv/Edge/Thread Granularity of Events for Micro-op Flow	B-17
Table B-4.	Cycle Accounting of Wasted Work Due to Misprediction	B-18
Table B-5.	Cycle Accounting of Instruction Starvation.	B-19
Table B-6.	CMask/Inv/Edge/Thread Granularity of Events for Micro-op Flow	B-20
Table B-7.	Approximate Latency of L2 Misses of Intel Xeon Processor 5500.	B-22
Table B-8.	Load Latency Event Programming	B-25
Table B-9.	Data Source Encoding for Load Latency PEBS Record.	B-25
Table B-10.	Core PMU Events to Drill Down L2 Misses	B-29
Table B-11.	Core PMU Events for Super Queue Operation.	B-30
Table B-12.	Core PMU Event to Drill Down OFFCore Responses	B-30
Table B-13.	OFFCORE_RSP_0 MSR Programming.	B-30
Table B-14.	Common Request and Response Types for OFFCORE_RSP_0 MSR.	B-31
Table B-15.	Uncore PMU Events for Occupancy Cycles.	B-36
Table B-16.	Common QHL Opcode Matching Facility Programming.	B-38
Table C-1.	Core TLB Structure Size and Organization Across Multiple Intel Product Generations	C-2
Table C-2.	Calculating ITLB Miss Stall for Ghost.js	C-3
Table C-3.	ITLB MPKI and Executable Sizes Across Various Workloads.	C-5
Table C-4.	Key Metrics for Ghost.js With and Without Large Pages	C-11
Table C-5.	Key Metrics for Web Tooling across Clear Linux and Ubuntu 18.04	C-12
Table C-6.	Key Metrics for MediaWiki Workload on HHVM.	C-12
Table C-7.	Precise Front-end Events for ITLB Misses	C-13
Table C-8.	System Details	C-16
Table C-9.	Processor Information	C-16
Table C-10.	Kernel Vulnerability Status	C-17
Table D-1.	CPUID Signature Values of Of Recent Intel Microarchitectures.	D-3
Table D-2.	Instruction Extensions Introduction by Microarchitectures (CPUID Signature).	D-4
Table D-3.	BMI1, BMI2 and General Purpose Instructions	D-4
Table D-4.	256-bit AVX2 Instructions	D-5
Table D-5.	Gather Timing Data from L1D*	D-6
Table D-6.	BMI1, BMI2 and General Purpose Instructions	D-7
Table D-7.	F16C, RDRAND Instructions.	D-7
Table D-8.	256-bit AVX Instructions.	D-7
Table D-9.	AESNI and PCLMULQDQ Instructions	D-9
Table D-10.	SSE4.2 Instructions	D-10
Table D-11.	SSE4.1 Instructions	D-10
Table D-12.	Supplemental Streaming SIMD Extension 3 Instructions.	D-11
Table D-13.	Streaming SIMD Extension 3 SIMD Floating-point Instructions	D-12
Table D-14.	Streaming SIMD Extension 2 128-bit Integer Instructions	D-12
Table D-15.	Streaming SIMD Extension 2 Double-precision Floating-point Instructions.	D-14
Table D-16.	Streaming SIMD Extension Single-precision Floating-point Instructions.	D-15
Table D-17.	General Purpose Instructions	D-17
Table D-18.	Pointer-Chasing Variability of Software Measurable Latency of L1 Data Cache Latency.	D-20
Table E-1.	Dispatch Port and Execution Stacks of the Haswell Microarchitecture	E-3
Table E-2.	Haswell Microarchitecture Execution Units and Representative Instructions	E-4
Table E-3.	Bypass Delay Between Producer and Consumer Micro-ops (cycles)	E-5
Table E-4.	Cache Parameters of the Haswell Microarchitecture	E-5
Table E-5.	TLB Parameters of the Haswell Microarchitecture	E-6
Table E-6.	Components of the Front End	E-6
Table E-7.	TLB Parameters of the Broadwell Microarchitecture	E-8
Table E-8.	Components of the Front End of Sandy Bridge Microarchitecture.	E-10
Table E-9.	ICache and ITLB of Sandy Bridge Microarchitecture	E-11
Table E-10.	Dispatch Port and Execution Stacks.	E-16
Table E-11.	Execution Core Writeback Latency (cycles)	E-17
Table E-12.	Cache Parameters	E-18
Table E-13.	Lookup Order and Load Latency	E-18

Table E-14.	L1 Data Cache Components	E-19
Table E-15.	Effect of Addressing Modes on Load Latency.....	E-20
Table E-16.	DTLB and STLB Parameters	E-21
Table E-17.	Store Forwarding Conditions (1 and 2 byte stores)	E-21
Table E-18.	Store Forwarding Conditions (4-16 byte stores).....	E-22
Table E-19.	32-byte Store Forwarding Conditions (0-15 byte alignment)	E-22
Table E-20.	32-byte Store Forwarding Conditions (16-31 byte alignment).....	E-22
Table E-21.	Components of the Front End	E-28
Table E-22.	Issue Ports of Intel Core Microarchitecture and Enhanced Intel Core Microarchitecture.....	E-33
Table E-23.	Cache Parameters of Processors based on Intel Core Microarchitecture.....	E-38
Table E-24.	Characteristics of Load and Store Operations in Intel Core Microarchitecture... ..	E-39
Table E-25.	Bypass Delay Between Producer and Consumer Micro-ops (cycles)	E-44
Table E-26.	Issue Ports of Nehalem Microarchitecture.....	E-44
Table E-27.	Cache Parameters of Intel Core i7 Processors	E-45
Table E-28.	Performance Impact of Address Alignments of MOVDQU from L1	E-46
Table F-1.	Instruction Latency/Throughput Summary of Intel Atom® Microarchitecture	F-7
Table F-2.	Intel Atom® Microarchitecture Instructions Latency Data	F-14
Table F-3.	Function Unit Mapping of the Silvermont Microarchitecture	F-21
Table F-5.	Comparison of Distributed Reservation Stations on Scheduling Uops	F-25
Table F-6.	Function Unit Mapping of the Goldmont Microarchitecture	F-25
Table F-4.	Comparison of Front End Cluster Features	F-25
Table F-7.	Comparison of MEC Resources.....	F-26
Table F-8.	Comparison of Front End Cluster Features	F-27
Table F-9.	Comparison of Distributed Reservation Stations on Scheduling Uops	F-28
Table F-10.	Function Unit Mapping of the Goldmont Plus Microarchitecture.....	F-28
Table F-11.	Alternatives to MSROM Instructions	F-29
Table F-12.	Comparison of Decoder Capabilities.....	F-31
Table F-13.	Integer Multiply Operation Latency	F-34
Table F-14.	Floating-Point and SIMD Integer Latency	F-37
Table F-15.	Unsigned Integer Division Operation Latency.....	F-38
Table 6-16.	Signed Integer Division Operation Latency	F-39
Table F-17.	Store Forwarding Conditions (1 and 2 Byte Stores).....	F-40
Table F-18.	Store Forwarding Conditions (4-16 Byte Stores).....	F-40
Table F-19.	Instructions Latency and Throughput Recent Microarchitectures for Intel Atom® Processors.....	F-42

The *Intel® 64 and IA-32 Architectures Optimization Reference Manual* describes how to optimize software to take advantage of the performance characteristics of IA-32 and Intel 64 architecture processors.

The target audience for this manual includes software programmers and compiler writers. This manual assumes that the reader is familiar with the basics of the IA-32 architecture and has access to the *Intel® 64 and IA-32 Architectures Software Developer's Manual*. A detailed understanding of Intel 64 and IA-32 processors is often required. In many cases, knowledge of the underlying microarchitectures is required.

The design guidelines discussed in this manual for developing high-performance software generally apply to current and future IA-32 and Intel 64 processors. In most cases, coding rules apply to software running in 64-bit mode of Intel 64 architecture, compatibility mode of Intel 64 architecture, and IA-32 modes (IA-32 modes are supported in IA-32 and Intel 64 architectures). Coding rules specific to 64-bit modes are noted separately.

NOTE

A public repository is available with open source code samples from select chapters of this manual. These code samples are released under a 0-Clause BSD license. Intel provides additional code samples and updates to the repository as the samples are created and verified.

Public repository: <https://github.com/intel/optimization-manual>.

Link to license: <https://github.com/intel/optimization-manual/blob/master/COPYING>.

1.1 TUNING YOUR APPLICATION

Tuning an application for high performance on any Intel 64 or IA-32 processor requires understanding and basic skills in:

- Intel 64 and IA-32 architecture.
- C and Assembly language.
- Hot-spot regions in the application that impact performance.
- Optimization capabilities of the compiler.
- Techniques used to evaluate application performance.

The Intel® VTune™ Performance Analyzer can help you analyze and locate hot-spot regions in your applications. On the Intel® Core™ i7, Intel® Core™2 Duo, Intel® Core™ Duo, Intel® Core™ Solo, Pentium® 4, Intel® Xeon®, and Intel® Pentium® M processors, this tool can monitor an application through a selection of performance monitoring events and analyze the performance event data that is gathered during code execution.

This manual also describes data that can be gathered using the performance counters through the processor's performance monitoring events.

1.2 ABOUT THIS MANUAL

The Intel® Core™ i7 processor and Intel® Xeon® processor 3400, 5500, 7500 series are based on 45 nm Nehalem microarchitecture. Westmere microarchitecture is a 32 nm version of the Nehalem microarchitecture. Intel® Xeon® processor 5600 series, Intel Xeon processor E7 and various Intel Core i7, i5, i3 processors are based on the Westmere microarchitecture. These processors support Intel 64 architecture.

INTRODUCTION

The Intel® Xeon® processor E5 family, Intel® Xeon® processor E3-1200 family, Intel® Xeon® processor E7-8800/4800/2800 product families, Intel® Core™ i7-3930K processor, and 2nd generation Intel® Core™ i7-2xxx, Intel® Core™ i5-2xxx, Intel® Core™ i3-2xxx processor series are based on the Sandy Bridge microarchitecture and support Intel 64 architecture.

The Intel® Xeon® processor E7-8800/4800/2800 v2 product families, Intel® Xeon® processor E3-1200 v2 product family and 3rd generation Intel® Core™ processors are based on the Ivy Bridge microarchitecture and support Intel 64 architecture.

The Intel® Xeon® processor E5-4600/2600/1600 v2 product families, Intel® Xeon® processor E5-2400/1400 v2 product families and Intel® Core™ i7-49xx Processor Extreme Edition are based on the Ivy Bridge-E microarchitecture and support Intel 64 architecture.

The Intel® Xeon® processor E3-1200 v3 product family and 4th Generation Intel® Core™ processors are based on the Haswell microarchitecture and support Intel 64 architecture.

The Intel® Xeon® processor E5-2600/1600 v3 product families and the Intel® Core™ i7-59xx Processor Extreme Edition are based on the Haswell-E microarchitecture and support Intel 64 architecture.

The Intel Atom® processor Z8000 series is based on the Airmont microarchitecture.

The Intel Atom® processor Z3400 series and the Intel Atom® processor Z3500 series are based on the Silvermont microarchitecture.

The Intel® Core™ M processor family, 5th generation Intel® Core™ processors, Intel® Xeon® processor D-1500 product family and the Intel® Xeon® processor E5 v4 family are based on the Broadwell microarchitecture and support Intel 64 architecture.

The Intel® Xeon® Processor Scalable Family, Intel® Xeon® processor E3-1500m v5 product family and 6th generation Intel® Core™ processors are based on the Skylake microarchitecture and support Intel 64 architecture.

The 7th generation Intel® Core™ processors are based on the Kaby Lake microarchitecture and support Intel 64 architecture.

The Intel Atom® processor C series, the Intel Atom® processor X series, the Intel® Pentium® processor J series, the Intel® Celeron® processor J series, and the Intel® Celeron® processor N series are based on the Goldmont microarchitecture.

The Intel® Xeon Phi™ Processor 3200, 5200, 7200 Series is based on the Knights Landing microarchitecture and supports Intel 64 architecture.

The Intel® Pentium® Silver processor series, the Intel® Celeron® processor J series, and the Intel® Celeron® processor N series are based on the Goldmont Plus microarchitecture.

The 8th generation Intel® Core™ processors, 9th generation Intel® Core™ processors, and Intel® Xeon® E processors are based on the Coffee Lake microarchitecture and support Intel 64 architecture.

The Intel® Xeon Phi™ Processor 7215, 7285, 7295 Series is based on the Knights Mill microarchitecture and supports Intel 64 architecture.

The 2nd generation Intel® Xeon® Processor Scalable Family is based on the Cascade Lake product and supports Intel 64 architecture.

Some 10th generation Intel® Core™ processors are based on the Ice Lake microarchitecture, and some are based on the Comet Lake microarchitecture; both support Intel 64 architecture.

Some 11th generation Intel® Core™ processors are based on the Tiger Lake microarchitecture, and some are based on the Rocket Lake microarchitecture; both support Intel 64 architecture.

Some 3rd generation Intel® Xeon® Processor Scalable Family processors are based on the Cooper Lake product, and some are based on the Ice Lake microarchitecture; both support Intel 64 architecture.

The 12th generation Intel® Core™ processors are based on the Alder Lake performance hybrid architecture and support Intel 64 architecture.

The Intel® 4th generation Intel® Xeon® Scalable Processor Family is based on Sapphire Rapids microarchitecture and uses Golden Cove cores.

The chapters in this manual are summarized below.

- **Chapter 1: Introduction** — Defines the purpose and outlines the contents of this manual.
- **Chapter 2: Intel® 64 and IA-32 Processor Architectures** — Describes the microarchitecture of recent Intel 64 and IA-32 processor families, and other features relevant to software optimization.
- **Chapter 3: General Optimization Guidelines** — Describes general code development and optimization techniques that apply to all applications designed to take advantage of the common features of current Intel processors.
- **Chapter 4: Intel Atom® Processor Architecture** — Describes the microarchitecture of recent Intel Atom processor families, and other features relevant to software optimization.
- **Chapter 5: Coding for SIMD Architectures** — Describes techniques and concepts for using the SIMD integer and SIMD floating-point instructions provided by the MMX™ technology, Streaming SIMD Extensions, Streaming SIMD Extensions 2, Streaming SIMD Extensions 3, SSSE3, and SSE4.1.
- **Chapter 6: Optimizing for SIMD Integer Applications** — Provides optimization suggestions and common building blocks for applications that use the 128-bit SIMD integer instructions.
- **Chapter 7: Optimizing for SIMD Floating-point Applications** — Provides optimization suggestions and common building blocks for applications that use the single-precision and double-precision SIMD floating-point instructions.
- **Chapter 8: INT8 Deep Learning Inference** — Describes INT8 as a data type for Deep learning Inference on Intel technology. The document covers both AVX-512 implementations and implementations using the new Intel® DL Boost Instructions.
- **Chapter 9: Optimizing Cache Usage** — Describes how to use the PREFETCH instruction, cache control management instructions to optimize cache usage, and the deterministic cache parameters.
- **Chapter 10: Introducing Sub-NUMA Clustering** — Describes Sub-NUMA Clustering (SNC), a mode for improving average latency from last level cache (LLC) to local memory.
- **Chapter 11: Multicore and Hyper-Threading Technology** — Describes guidelines and techniques for optimizing multithreaded applications to achieve optimal performance scaling. Use these when targeting multicore processor, processors supporting Hyper-Threading Technology, or multiprocessor (MP) systems.
- **Chapter 12: Intel® Optane™ DC Persistent Memory** — Provides optimization suggestions for applications that use Intel® Optane™ DC Persistent Memory.
- **Chapter 13: 64-Bit Mode Coding Guidelines** — This chapter describes a set of additional coding guidelines for application software written to run in 64-bit mode.
- **Chapter 14: SSE4.2 and SIMD Programming for Text-Processing/Lexing/Parsing**— Describes SIMD techniques of using SSE4.2 along with other instruction extensions to improve text/string processing and lexing/parsing applications.
- **Chapter 15: Optimizations for Intel® AVX, FMA, and Intel® AVX2**— Provides optimization suggestions and common building blocks for applications that use Intel® Advanced Vector Extensions, FMA, and Intel® Advanced Vector Extensions 2 (Intel® AVX2).
- **Chapter 16: Intel Transactional Synchronization Extensions** — Tuning recommendations to use lock elision techniques with Intel Transactional Synchronization Extensions to optimize multi-threaded software with contended locks.
- **Chapter 17: Power Optimization for Mobile Usages** — This chapter provides background on power saving techniques in mobile processors and makes recommendations that developers can leverage to provide longer battery life.
- **Chapter 18: Software Optimization for Intel® AVX-512 Instructions**— Provides optimization suggestions and common building blocks for applications that use Intel® Advanced Vector Extensions 512.
- **Chapter 19: Intel® Advanced Vector Extensions 512-FP16 Instruction Set for Intel® Xeon® Processors** — Describes the addition of the FP16 ISA for Intel AVX-512 to handle IEEE 754-2019 compliant half-precision floating-point operations.

- **Chapter 20: Intel® Advanced Matrix Extensions (Intel® AMX)** — Describes best practices to optimally code to the metal on Intel® Xeon® Processors based on Sapphire Rapids SP microarchitecture. It extends the public documentation on Optimizing DL code with DL Boost instructions.
- **Chapter 21: Cryptography & Finite Field Arithmetic Enhancements** — Describes the new instruction extensions designated for acceleration of cryptography flows and finite field arithmetic.
- **Chapter 22: Intel QuickAssist Technology** — Describes software development guidelines for the QuickAssist Technology (QAT) API. This API supports both the Cryptographic and Data Compression services.
- **Chapter 23: Knights Landing Microarchitecture and Software Optimization** — Describes the microarchitecture of processor families based on the Knights Landing microarchitecture, and software optimization techniques targeting Intel processors based on the Knights Landing microarchitecture.
- **Appendix A: Application Performance Tools** — Introduces tools for analyzing and enhancing application performance without having to write assembly code.
- **Appendix B: Using Performance Monitoring Events** — Provides information on the Top-Down Analysis Method and information on how to use performance events specific to the Intel Xeon processor 5500 series, processors based on Sandy Bridge microarchitecture, and Intel Core Solo and Intel Core Duo processors.
- **Appendix C: Intel Architecture Optimization with Large Code Pages** — Provides information on how the performance of runtimes can be improved by using large code pages.
- **Appendix D: IA-32 Instruction Latency and Throughput** — Provides latency and throughput data for the IA-32 instructions. Instruction timing data specific to recent processor families are provided.
- **Appendix E: Earlier Generations of Intel® 64 and IA-32 Processor Architectures** — Describes the microarchitecture of earlier generations of Intel 64 and IA-32 processor families, and other features relevant to software optimization.
- **Appendix F: Earlier Generations of Intel Atom® Microarchitecture and Software Optimization** — Describes the microarchitecture of earlier generations of processor families based on Intel Atom microarchitecture, and software optimization techniques targeting Intel Atom microarchitecture.

1.3 RELATED INFORMATION

For more information on the Intel® architecture, techniques, and the processor architecture terminology, the following are of particular interest:

- [Intel® 64 and IA-32 Architectures Software Developer’s Manual](#)
- [Developing Multi-threaded Applications: A Platform Consistent Approach](#)
- [Intel® C++ Compiler documentation and online help](#)
- [Intel® Fortran Compiler documentation and online help](#)
- [Intel® VTune™ Amplifier documentation and online help](#)
- [Using Spin-Loops on Intel Pentium 4 Processor and Intel Xeon Processor MP](#)

More relevant links are:

- Developer Zone:
<https://software.intel.com/en-us/all-dev-areas>
- Processor support general link:
<https://www.intel.com/content/www/us/en/products/processors.html>
- Intel Multi-Core Technology:
<https://software.intel.com/en-us/articles/multi-core-introduction>
- Hyper-Threading Technology (HT Technology):

<http://www.intel.com/content/www/us/en/architecture-and-technology/hyper-threading/hyper-threading-technology.html>

- SSE4.1 Application Note: Motion Estimation with Intel® Streaming SIMD Extensions 4:
<https://software.intel.com/en-us/articles/motion-estimation-with-intel-streaming-simd-extensions-4-intel-sse4>
- Intel® SSE4 Programming Reference:
<https://software.intel.com/sites/default/files/m/8/b/8/D9156103.pdf>
- Intel® 64 Architecture Processor Topology Enumeration:
<https://software.intel.com/en-us/articles/intel-64-architecture-processor-topology-enumeration>
- Multi-buffering techniques using SIMD extensions:
<http://www.intel.com/content/dam/www/public/us/en/documents/white-papers/communications-ia-multi-buffer-paper.pdf>
- Parallel hashing using Multi-buffering techniques:
<http://www.scirp.org/journal/PaperInformation.aspx?paperID=23995>
<http://eprint.iacr.org/2012/476.pdf>
- PCMMULQDQ resources:
<https://software.intel.com/en-us/articles/intel-carry-less-multiplication-instruction-and-its-usage-for-computing-the-gcm-mode>
- Modular exponentiation using redundant representation and AVX2:
http://rd.springer.com/chapter/10.1007%2F978-3-642-31662-3_9?LI=true

CHAPTER 2

INTEL® 64 AND IA-32 PROCESSOR ARCHITECTURES

This chapter gives an overview of features relevant to software optimization for current generations of Intel® 64 and IA-32 processors¹. These features are:

- Microarchitectures that enable executing instructions with high throughput at high clock rates, a high speed cache hierarchy, and high speed system bus.
- Hyper-Threading Technology² (HT Technology) support.
- Intel 64 architecture on Intel 64 processors.
- SIMD instruction extensions: MMX technology, Streaming SIMD Extensions (SSE), Streaming SIMD Extensions 2 (SSE2), Streaming SIMD Extensions 3 (SSE3), Supplemental Streaming SIMD Extensions 3 (SSSE3), SSE4.1, and SSE4.2.
- Intel® Advanced Vector Extensions (Intel® AVX).
- Half-precision floating-point conversion and RDRAND.
- Fused Multiply Add Extensions.
- Intel® Advanced Vector Extensions 2 (Intel® AVX2).
- ADX and RDSEED.
- Intel® Advanced Vector Extensions 512 (Intel® AVX-512).
- Intel® Thread Director

2.1 SAPPHIRE RAPIDS ARCHITECTURE

Sapphire Rapids uses Intel® Golden Cove-based cores and features Intel® Advanced Vector Extensions 512 (Intel® AVX-512) (Chapter 19), Intel® Transactional Synchronization Extensions (Intel® TSX) Suspend Load Address Tracking (TSXLDTRK), Advanced Matrix Extensions (AMX) (Chapter 20), Intel Data Streaming Accelerator (DSA)³, and Intel In-Memory Analytics Accelerator (IAA)⁴.

2.1.1 Intel® 4th generation Intel® Xeon® Scalable Family of Processors

Intel's fourth generation Xeon Scalable Family of Processors (Sapphire Rapids) changes from a single-die monolithic design to multi-die Tiles.

The server products are scalable from dual-socket to eight-socket configurations (Section 3.11).

Its I/O includes PCI Express 5.0, DDR5 memory, and Compute Express Link 1.1.

Packaging includes a multi-die chip with up to 4 tiles. Each tile is a 400mm² SoC, providing both compute cores and I/O.

Each tile contains 15 Golden Cove cores (see Section 2.3). Its memory controller provides two channels of DDR5 with a maximum of eight channels across 4 tiles, and 28 PCIe 5.0 lanes for a maximum of 112 across 4 tiles.

1. For previous generations of Intel 64 and IA-32 processors, see Appendix E, "Earlier Generations of Intel® 64 and IA-32 Processor Architectures." Intel Atom® processors are covered in Chapter 4, "Intel Atom® Processor Architectures."
2. Hyper-Threading Technology requires a computer system with an Intel processor supporting HT Technology and an HT Technology enabled chipset, BIOS and operating system. Performance varies depending on the hardware and software used.
3. Please see the DSA Specification: <https://cdrdv2.intel.com/v1/dl/getContent/671116> and User Guide: <https://cdrdv2.intel.com/v1/dl/getContent/759709>
4. Please see the IAA Specification: <https://cdrdv2.intel.com/v1/dl/getContent/721858>

2.2 ALDER LAKE PERFORMANCE HYBRID ARCHITECTURE

The Alder Lake performance hybrid architecture combines two Intel architectures, bringing together the Golden Cove performant cores and the Gracemont efficient Atom cores onto a single SoC. For details on the Golden Cove microarchitecture, see Section 2.3, “Golden Cove Microarchitecture.” For details on the Gracemont microarchitecture, see Section 4.1, “Gracemont Microarchitecture.”

2.2.1 12th Generation Intel® Core™ Processors Supporting Performance Hybrid Architecture

12th Generation Intel® Core™ processors supporting performance hybrid architecture consist of up to eight Performance cores (P-cores) and eight Efficient cores (E-cores). These processors also include a 3MB Last Level Cache (LLC) per IDI module, where a module is one P-core or four E-cores. It has symmetrical ISA and comes in variety of configurations.

P-cores provide single or limited thread performance, while E-cores help provide improved scaling and multithreaded efficiency. P-cores on these processors can also have Intel® Hyper-Threading Technology enabled. All cores can be active simultaneously when the operating system (OS) decides to schedule on all processors.

A key OSV requirement for enabling hybrid is symmetric ISA across different core types in a performance hybrid architecture. In 12th Generation Intel Core processors supporting performance hybrid architecture, ISA is converged to a common baseline between the P-cores and E-cores. In order to maintain symmetric ISA, the E-cores do not support the following features: Intel AVX-512, Intel AVX-512 FP-16, and Intel® TSX. The E-cores do support Intel AVX2 and Intel AVX-VNNI.

2.2.2 Hybrid Scheduling

2.2.2.1 Intel® Thread Director

Intel® Thread Director continually monitors software in real-time giving hints to the operating system's scheduler allowing it to make more intelligent and data-driven decisions on thread scheduling. With Intel Thread Director, hardware provides runtime feedback to the OS per thread based on various IPC performance characteristics, in the form of:

- Dynamic performance and energy efficiency capabilities of P-cores and E-cores based on power/thermal limits.
- Idling hints when power and thermal are constrained.

Intel Thread Director is first introduced in desktop and mobile variants of the 12th generation Intel Core processor based on Alder Lake performance hybrid architecture.

A processor containing both P-cores and E-cores with different performance characteristics creates a challenge for the operating system's scheduler. Additionally, different software threads see different performance ratios between the P-cores and E-cores. For example, the performance ratio between the P-cores and E-cores for highly vectorized floating-point code is higher than the performance ratio for scalar integer code. So, when the operating system needs to make an optimal scheduling decision it needs to be aware of the characteristics of the software threads that are candidates for scheduling. If not enough P-cores are available and there is a mix of software threads with different characteristics, the operating system should schedule those threads that benefit most from the P-cores onto those cores and schedule the others on the E-cores.

Intel Thread Director provides the necessary hint to the operating system about the characteristics of the software thread executing on each of the logical processors. The hint is dynamic and reflects the recent characteristics of the thread, i.e., it may change over time based on the dynamic instruction mix of the thread. The processor also considers microarchitecture factors to define the dynamic software thread characteristics.

Thread specific hardware support is enumerated via the CPUID instruction and enabled by the operating system via writing to configuration MSRs. The Intel Thread Director implementation on processors based on Alder Lake performance hybrid architecture defines four thread classes:

0. Non-vectorized integer or floating-point code.
1. Integer or floating-point vectorized code, excluding Intel® Deep Learning Boost (Intel® DL Boost) code.
2. Intel DL Boost code.
3. Pause (spin-wait) dominated code.

The dynamic code does not have to be 100% of the class definition. It should be large enough to be considered belonging to that class. Also, dynamic microarchitectural metrics such as consumed memory bandwidth or cache bandwidth may move software threads between classes. Example pseudo-code sequences for the Intel Thread Director classes available on processors based on Alder Lake performance hybrid architecture are provided in the examples 2-1 through 2-4.

Intel Thread Director also provides a table in system memory, only accessible to the operating system, that defines the P-core vs. E-core performance ratio per class. This allows the operating system to pick and choose the right software thread for the right logical processor.

In addition to the performance ratio between P-cores and E-cores, Intel Thread Director provides the energy efficiency ratio between those cores. The operating system can then use this information when it prefers energy savings over maximum performance. For example, a background task such as indexing can be scheduled on the most energy efficient core since its performance is less critical.

Example 2-1. Class 0 Pseudo-code Snippet

```

while (1)
{
    asm("xor rax, rax;"
        "add rax, 5;"
        "inc rax;"
    );
}

```

Example 2-2. Class 1 Pseudo-code Snippet

```

while (1)
{
    asm("vfmaddsub132ps %ymm0, %ymm1, %ymm2;"
        "vfmaddsub213ps %ymm0, %ymm1, %ymm3;"
        "vfmaddsub231ps %ymm0, %ymm1, %ymm4;"
        "vfmaddsub132ps %ymm0, %ymm1, %ymm5;"
        "vfmaddsub213ps %ymm0, %ymm1, %ymm6;"
        "vfmaddsub231ps %ymm0, %ymm1, %ymm7;"
        "vfmaddsub132ps %ymm0, %ymm1, %ymm8;"
        "vfmaddsub213ps %ymm0, %ymm1, %ymm9;"
        "vfmaddsub231ps %ymm0, %ymm1, %ymm10;"
        "vfmaddsub132ps %ymm0, %ymm1, %ymm2;"
        "vfmaddsub213ps %ymm0, %ymm1, %ymm3;"
        "vfmaddsub231ps %ymm0, %ymm1, %ymm4;"
        "vfmaddsub132ps %ymm0, %ymm1, %ymm5;"
        "vfmaddsub213ps %ymm0, %ymm1, %ymm6;"
        "vfmaddsub231ps %ymm0, %ymm1, %ymm7;"
        "vfmaddsub132ps %ymm0, %ymm1, %ymm8;"
        "vfmaddsub213ps %ymm0, %ymm1, %ymm9;"
        "vfmaddsub231ps %ymm0, %ymm1, %ymm10;"
        "vfmaddsub132ps %ymm0, %ymm1, %ymm2;"
        "vfmaddsub213ps %ymm0, %ymm1, %ymm3;"
        "vfmaddsub231ps %ymm0, %ymm1, %ymm4;"
        "vfmaddsub132ps %ymm0, %ymm1, %ymm5;"
        "vfmaddsub213ps %ymm0, %ymm1, %ymm6;"
        "vfmaddsub231ps %ymm0, %ymm1, %ymm7;"
        "vfmaddsub132ps %ymm0, %ymm1, %ymm8;"
    );
}

```

Example 2-2. Class 1 Pseudo-code Snippet (Contd.)

```

    "vfmaddsub213ps %ymm0, %ymm1, %ymm9;"
    "vfmaddsub231ps %ymm0, %ymm1, %ymm10;"
    "vfmaddsub132ps %ymm0, %ymm1, %ymm2;"
};
}

```

Example 2-3. Class 2 Pseudo-code Snippet

```

while (1)
{
    __asm(
        vpdpsd ymm2, ymm0, ymm1
        vpdpsd ymm3, ymm0, ymm1
        vpdpsd ymm4, ymm0, ymm1
        vpdpsd ymm5, ymm0, ymm1
        vpdpsd ymm6, ymm0, ymm1
        vpdpsd ymm7, ymm0, ymm1
        vpdpsd ymm8, ymm0, ymm1
        vpdpsd ymm9, ymm0, ymm1
        vpdpsd ymm10, ymm0, ymm1
        vpdpsd ymm11, ymm0, ymm1
        vpdpsd ymm12, ymm0, ymm1
        vpdpsd ymm13, ymm0, ymm1
    );
}

```

Example 2-4. Class 3 Pseudo-code Snippet

```

while (1)
{
    asm("PAUSE;")
    asm("PAUSE;")
    asm("PAUSE;")
    asm("PAUSE;")
    asm("PAUSE;")
    asm("PAUSE;")
    asm("PAUSE;")
    asm("PAUSE;")
    asm("PAUSE;")
    asm("PAUSE;")
    asm("PAUSE;")
};
}

```

For more detailed information on this technology, refer to the Intel® 64 and IA-32 Architectures Software Developer Manuals located here: www.intel.com/sdm.

2.2.2.2 Scheduling with Intel Hyper-Threading Technology Enabled on Processors Supporting x86 Hybrid Architecture

E-cores are designed to provide better performance than a logical P-core with both hardware sibling hyper-threads busy.

2.2.2.3 Scheduling with a Multi-E-Core Module

E-cores within an idle module help provide better performance than E-cores in a busy module.

2.2.2.4 Scheduling Background Threads on x86 Hybrid Architecture

In most scenarios, background threads can leverage scalability and multithread efficiency of E-cores.

2.2.3 Recommendations for Application Developers

The following are recommendations when using processors supporting performance hybrid architecture:

- Stay up to date on updates on operating systems and optimized libraries.
- Software needs to avoid setting hard affinities on either threads or processes in order to allow the operating system to provide the optimal core selection for Intel Hybrid.
- Software should replace active spin-waits with lightweight waits ideally using the new UMWAIT/TPAUSE and older PAUSE instructions which will allow for better hints to the scheduler on time spinning.
- Software can utilize the Windows Power Throttling information using process information and thread information APIs, to give hints to the scheduler on the Quality of Service (QoS) required for a particular thread or process to improve both performance and energy efficiency.
- Leverage Windows frameworks and media APIs for multimedia application development. Windows Media Foundation framework is optimized for hybrid architecture and enables media applications to run efficiently while preventing glitches.
- The Windows IrqPolicyMachineDefault policy enables Windows to optimally target interrupts to the right core, and more so on hybrid architecture.

For additional recommendations and information on performance hybrid architecture, refer to the white papers located here: <https://www.intel.com/content/www/us/en/developer/articles/technical/hybrid-architecture.html>.

2.3 GOLDEN COVE MICROARCHITECTURE

The Golden Cove microarchitecture is the successor of Ice Lake microarchitecture. The Golden Cove microarchitecture introduces the following enhancements:

- Wider machine: 5→6 wide allocation, 10→12 execution ports, and 4→8 wide retirement.
- Significant increases in the size of key structures enable deeper OOO execution and expose more instruction level parallelism.
- Greater capabilities per execution port, e.g., 5th integer ALU execution ports with expanded capability and a new fast floating-point adder.
- Intel® Advanced Matrix Extensions (Intel® AMX)¹: Built-in integrated Tiled Matrix Multiplication / Machine Learning Accelerator.
- Improved branch prediction.
- Improvements for large code footprint workloads, e.g., larger branch prediction structures, enhanced code prefetcher, and larger instruction TLB.
- Wider fetch: legacy decode pipeline fetch bandwidth increase to 32B/cycles, 4→6 decoders, increased micro-op cache size, and increased micro-op cache bandwidth.
- Maximum load bandwidth increased from 2 loads/cycle to 3 loads/cycle.
- Larger 4K Pages DTLB, increase in the number of outstanding Page Miss handlers.
- Increased number of outstanding misses (16 FB, 32→48 Deeper MLC miss queues).
- Enhanced data prefetchers for increased memory parallelism.
- Mid-level cache size increased to 2MB on server parts; remains 1.25MB on client parts.

1. Intel® Advanced Matrix Extensions are not available on Client parts.

2.3.1 Golden Cove Microarchitecture Overview

The basic pipeline functionality of the Golden Cove microarchitecture is depicted in Figure 2-1.

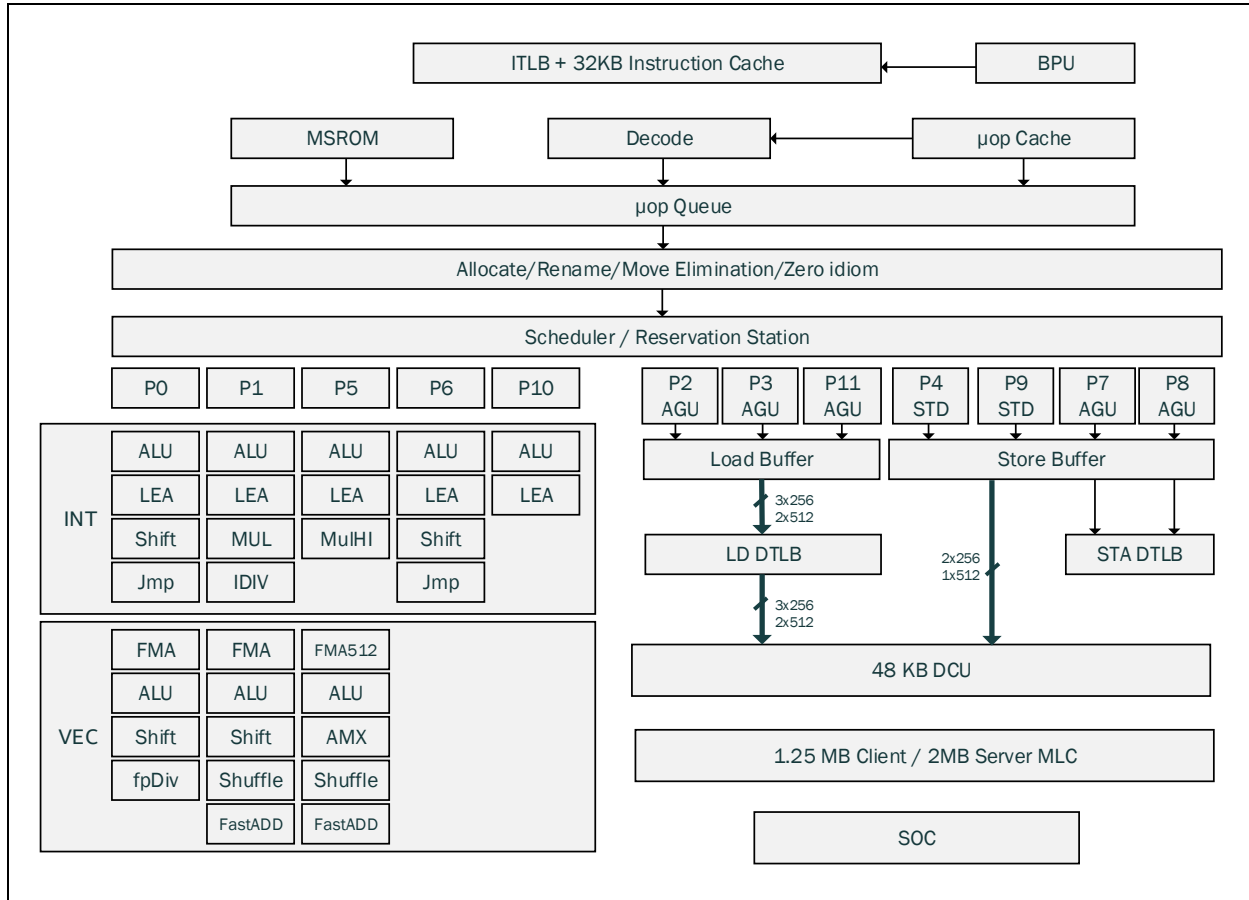

Figure 2-1. Processor Core Pipeline Functionality of the Golden Cove Microarchitecture

2.3.1.1 The Front End

The Golden Cove front end is depicted in Figure 2-2. The front end is built to feed the wider and deeper out-of-order core:

- Legacy decode pipeline fetch bandwidth increased from 16 to 32 bytes/cycle.
- The number of decoders increased from four to six, allowing decode of up to 6 instructions per cycle.
- The micro-op cache size increased, and its bandwidth increased to deliver up to 8 micro-ops per cycle.
- Improved branch prediction.

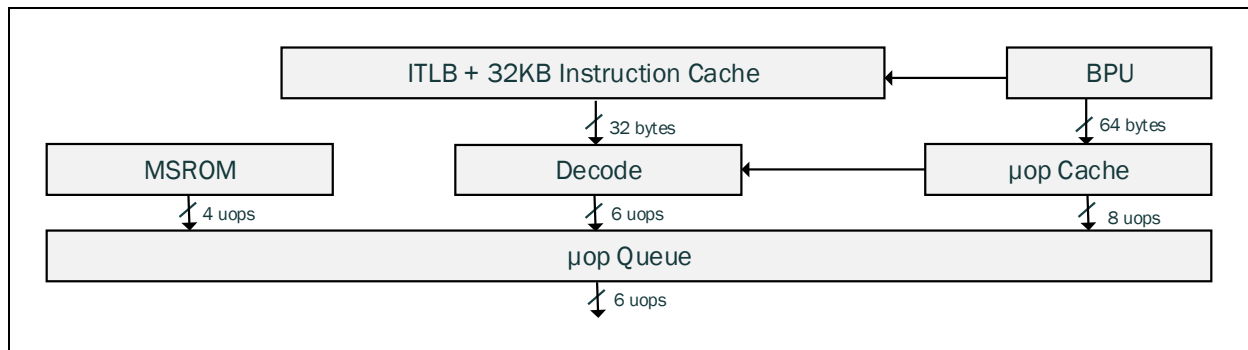

Figure 2-2. Processor Front End of the Golden Cove Microarchitecture

Improvements for large code footprint workloads:

- Double the size of the instruction TLB: 128→256 entries for 4K pages, 16→32 entries for 2M/4M pages.
- Bigger branch prediction structures.
- Enhanced code prefetcher.
- Improved LSD coverage.
- The IDQ can hold 144 uops per logical processor in single thread mode, or 72 uops per thread when SMT is active.

2.3.1.2 The Out-of-Order and Execution Engines

The Out-of-Order and execution engines changes in the Golden Cove microarchitecture include:

- Significant increase in size of key buffer structures to enable deeper OOO execution and expose more instruction level parallelism.
- Wider machine:
 - Wider allocation (5→6 uops per cycle) and retirement (4→8 uops per cycle) width.
 - Increase in number of execution ports (10→12).
 - Greater capabilities per execution port.

Table 2-1 summarizes the OOO engine's capability to dispatch different types of operations to ports.

Table 2-1. Dispatch Port and Execution Stacks of the Golden Cove Microarchitecture

Port 0	Port 1 ¹	Port 2	Port 3	Port 4	Port 5 ²	Port 6	Ports 7, 8	Port 9	Port 10	Port 11
INT ALU LEA INT Shift Jump1	INT ALU LEA INT Mul INT Div	Load	Load	Store Data	INT ALU LEA INTMUL Hi	INT ALU LEA INT Shift Jump2	Store Address	Store Data	INT ALU LEA	Load
FMA Vec ALU Vec Shift FP Div	FMA* Fast Adder* Vec ALU* Vec Shift* Shuffle*				FMA** Fast Adder Vec ALU Shuffle					

NOTES:

1. "*" in this table indicates that these features are not available for 512-bit vectors.
2. "**" in this table indicates that these features are not available for 512-bit vectors in Client parts.

Table 2-2 lists execution units and common representative instructions that rely on these units.

Throughput improvements across the SSE, Intel AVX, and general-purpose instruction sets are related to the number of units for the respective operations, and the varieties of instructions that execute using a particular unit.

Table 2-2. Golden Cove Microarchitecture Execution Units and Representative Instructions¹

Execution Unit	# of Unit	Instructions
ALU	5	add, and, cmp, or, test, xor, movzx, movsx, mov, (v)movdqu, (v)movdq, (v)movap*, (v)movup*
SHFT	2	sal, shl, rol, adc, sarx, adcx, adox, etc.
Slow Int	1	mul, imul, bsr, rcl, shld, mulx, pdep, etc.
BM	2	andn, bextr, blsi, blmsk, bzhi, etc.
Vec ALU	2x256-bit 1x512-bit	(v)add, (v)cmp, (v)max, (v)min, (v)sub, (v)cvtps2dq, (v)cvtdq2ps, (v)cvtsd2sl, (v)cvts2sl
	3x256-bit 2x512-bit	(v)pand, (v)por, (v)pxor, (v)movq, (v)movq, (v)movap*, (v)movup*, (v)andp*, (v)orp*, (v)paddb/w/d/q, (v)blendv*, (v)blendp*, (v)pblendd
Vec_Shft	2x256-bit 1x512-bit	(v)psllv*, (v)psrlv*, vector shift count in imm8
VEC Add (in VEC FMA)	2x256-bit 1x512-bit	(v)add*, (v)cmp*, (v)max*, (v)min*, (v)sub*, (v)padds*, (v)paddus*, (v)psign, (v)pabs, (v)pavgb, (v)pcmpeq*, (v)pmax, (v)cvtps2dq, (v)cvtdq2ps, (v)cvtsd2si, (v)cvts2si
VEC Fast Add	2x256-bit 1x512-bit	(v)add*, (v)addsub*, (v)sub*

Table 2-2. Golden Cove Microarchitecture Execution Units and Representative Instructions¹ (Contd.)

Execution Unit	# of Unit	Instructions
Shuffle	2x256-bit 1x512-bit	(v)shufp*, vperm*, (v)pack*, (v)unpck*, (v)punpck*, (v)pshuf*, (v)pslldq, (v)alignr, (v)pmovzx*, vbroadcast*, (v)pslldq, (v)psrldq, (v)pblendw (new cross lane shuffle on both ports)
Vec Mul/FMA	2x256-bit (1 or 2)x512-bit	(v)mul*, (v)pmul*, (v)pmadd*
SIMD Misc	1	STTNI, (v)pclmulqdq, (v)psadw, vector shift count in xmm
FP Mov	1	(v)movsd/ss, (v)movd gpr
DIVIDE	1	divp*, divs*, vdiv*, sqrt*, vsqrt*, rcp*, vrcp*, rsqrt*, idiv

NOTES:

1. Execution unit mapping to MMX instructions are not covered in this table. See Section 15.16.5 on MMX instruction throughput remedy.

Table 2-3 describes bypass delay in cycles between producer and consumer operations.

Table 2-3. Bypass Delay Between Producer and Consumer Micro-ops

FROM [EU/Port/Latency]	TO [EU/PORT/Latency]						
	SIMD/0,1/1	FMA/0,1/4	MUL/0,1/4	Fast Adder/1,5/3	SIMD/5/1,3	SHUF/1,5/1,3	V2I/0/3
SIMD/0,1/1	0	1	1	1	0	0	0
FMA/0,1/4	1	0	1	0	0	0	0
MUL/0,1/4	1	0	1	0	0	0	0
Fast Adder/0,1/3	1	0	1	-1	0	0	0
SIMD/5/1,3	0	1	1	1	0	0	0
SHUF/1,5/1,3	0	0	1	0	0	0	0
V2I/0/3	0	0	1	0	0	0	0
I2V/5/1	0	1	1	0	0	0	0

The attributes that are relevant to the producer/consumer micro-ops for bypass are a triplet of abbreviation/one or more port number/latency cycle of the uop. For example:

- "SIMD/0,1/1" applies to a 1-cycle vector SIMD uop dispatched to either port 0 or port 1.
- "SIMD/5/1,3" applies to either a 1-cycle or 3-cycle non-shuffle uop dispatched to port 5.
- "V2I/0/3" applies to a 3-cycle vector-to-integer uop dispatched to port 0.
- "I2V/5/1" applies to a 1-cycle integer-to-vector uop dispatched to port 5.
- "Fast Adder/1,5/3" applies to either a 3-cycle 256-bit uop dispatched to either port 1 or port 5, or a 512-bit uop dispatched to port 5. This operation supports two cycles back-to-back between a pair of Fast Adder operations.

A new Fast Adder¹ unit is added as 512-bit on port 5 in VEC stack, and as 256-bit on ports 1 and 5. The Fast Adder performs floating-point ADD/SUB operations in 3 cycles.

Back-to-back ADD/SUB operations that are both executed on the Fast Adder unit perform the operations in two cycles.

- In 128/256-bit, back-to-back ADD/SUB operations executed on the Fast Adder unit perform the operations in two cycles.
- In 512-bit, back-to-back ADD/SUB operations are executed in two cycles if both operations use the Fast Adder unit on port 5.

The following instructions are executed by the Fast Adder unit:

- (V)ADDSUBSS/SD/PS/PD
- (V)ADDSS/SD/PS/PD
- (V)SUBSS/SD/PS/PD

2.3.1.3 Cache Subsystem and Memory Subsystem

The cache subsystem and memory subsystem changes in the Golden Cove microarchitecture are:

- Maximum load bandwidth increased from 2 to 3 loads per cycle. Bandwidth of Intel AVX-512 loads, Intel AMX loads, and MMX/x87 loads remain at a maximum of 2 loads per cycle.
- Simultaneous handling of more loads and stores enabled by enlarged buffers.
- Number of entries for 4K pages in the load DTLB increased from 64 to 96.
- Page Miss handler can handle up to four D-side page walks in parallel instead of two.
- Increased number of outstanding DCU and MLC misses.
- Enhanced data prefetchers for increased memory parallelism.
- Partial store forwarding allowing forwarding data from store to load also when only part of the load was covered by the store (in case the load's offset matches the store's offset).

2.3.1.4 Avoiding Destination False Dependency

Some SIMD instructions incur false dependency on the destination operand. The following instructions are affected:

- VFMULCSH, VFMULCPH
- VFCMULCSH, VFCMULCPH
- VPERMD, VPERMQ, VPERMPS, VPERMPD
- VRANGE[SS,PS,SD,PD]
- VGETMANTSH, VGETMANTSS, VGETMANTSD
- VGETMANTPS, VGETMANTPD (memory versions only)
- VPMULLQ

1. The Fast Adder unit is not available on 512-bit vectors in Client parts.

Recommendation: Use dependency breaking zero idioms on the destination register before the affected instructions to avoid potential slowdown from the false dependency.

Example 2-5. Breaking False Dependency through Zero Idiom

Code with False Dependency Impact	Mitigation: Break False Dependency with Zero Idiom
<pre>vaddps zmm3, zmm4, zmm5 vmovaps [rsi], zmm3 vfmulcph zmm3, zmm2, zmm1 ;False dependency on zmm3.</pre> <p style="text-align: right;">Will not execute out-of-order until vaddps writes zmm3.</p>	<pre>vaddps zmm3, zmm4, zmm5 vmovaps [rsi], zmm3 vpxord zmm3, zmm3, zmm3 ;Dependency-breaking zero idiom. vfmulcph zmm3, zmm2, zmm1 ;Execute out-of-order without waiting for vaddps result.</pre>

2.4 ICE LAKE CLIENT MICROARCHITECTURE

The Ice Lake Client microarchitecture introduces the following new features that allow optimizations of applications for performance and power consumption:

- Targeted vector acceleration.
- Crypto acceleration.
- Intel® Software Guard Extensions (Intel® SGX) enhancements.
- Cache line writeback instruction (CLWB).

2.4.1 Ice Lake Client Microarchitecture Overview

The Ice Lake Client microarchitecture builds on the successes of the Skylake Client microarchitecture. The basic pipeline functionality of the Ice Lake Client microarchitecture is depicted in Figure 2-3.

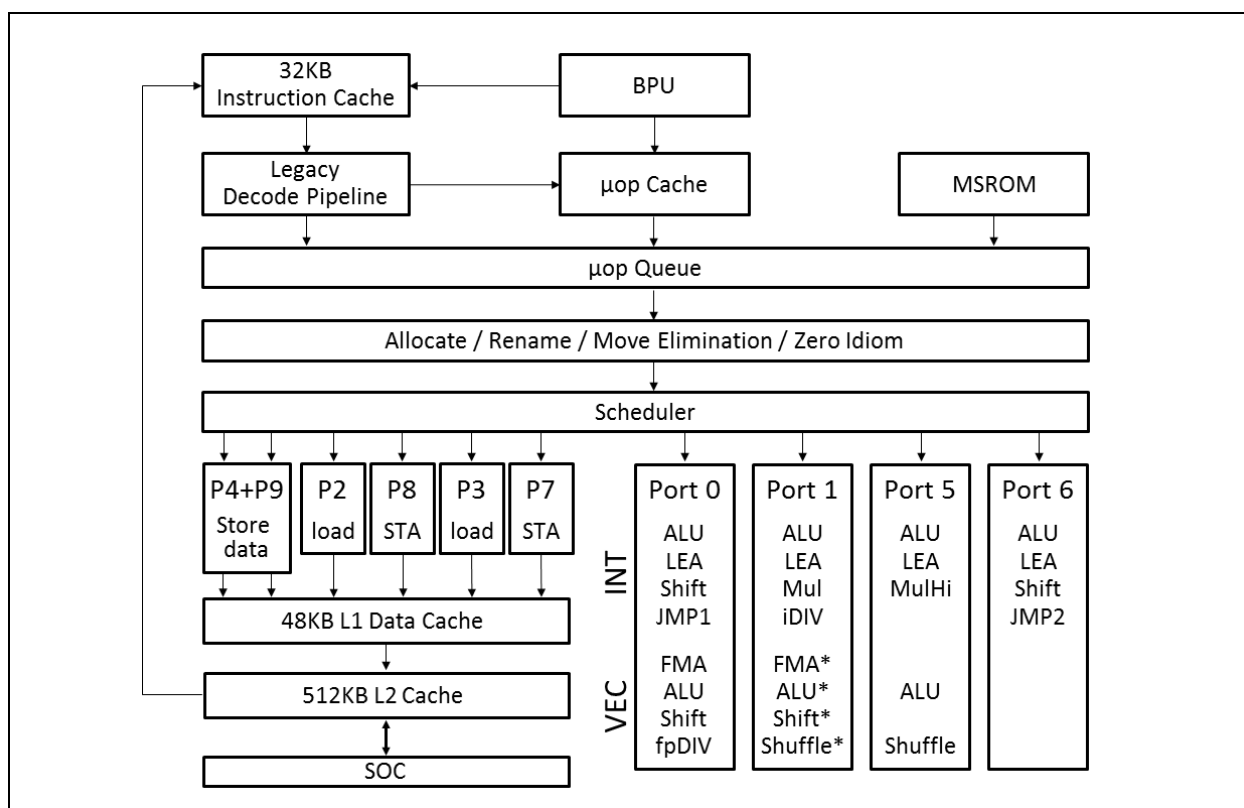

Figure 2-3. Processor Core Pipeline Functionality of the Ice Lake Client Microarchitecture¹

NOTES:

1. "*" in the figure above indicates these features are not available for 512-bit vectors.
2. "INT" represents GPR scalar instructions.
3. "VEC" represents floating-point and integer vector instructions.
4. "MulHi" produces the upper 64 bits of the result of an iMul operation that multiplies two 64-bit registers and places the result into two 64-bit registers.
5. The "Shuffle" on port 1 is new, and supports only in-lane shuffles that operate within the same 128-bit sub-vector.
6. The "iDIV" unit on port 1 is new, and performs integer divide operations at a reduced latency.

The Ice Lake Client microarchitecture introduces the following new features:

- Significant increase in size of key structures enable deeper OOO execution.
- Wider machine: 4 → 5 wide allocation, 8 → 10 execution ports.
- Intel AVX-512 (new for client processors): 512-bit vector operations, 512-bit loads and stores to memory, and 32 new 512-bit registers.
- Greater capabilities per execution port (e.g., SIMD shuffle, LEA), reduced latency Integer Divider.
- 2×BW for AES-NI peak throughput for existing binaries (microarchitectural).
- Rep move string acceleration.
- 50% increase in size of the L1 data cache.
- Reduced effective load latency.
- 2×L1 store bandwidth: 1 → 2 stores per cycle.
- Enhanced data prefetchers for increased memory parallelism.
- Larger 2nd level TLB.
- Larger uop cache.
- Improved branch predictor.
- Large page ITLB size in single thread mode doubled.
- Larger L2 cache.

The Ice Lake Client microarchitecture supports flexible integration of multiple processor cores with a shared uncore sub-system consisting of a number of components including a ring interconnect to multiple slices of L3, processor graphics, integrated memory controller, interconnect fabrics, and more.

2.4.1.1 The Front End

The front end changes in Ice Lake Client microarchitecture include:

- Improved branch predictor.
- Large page ITLB in single thread mode increased from 8 to 16 entries.
- Larger uop cache.
- The IDQ can hold 70 uops per logical processor vs. 64 uops per logical processor in previous generations when two sibling logical processors in the same core are active (2×70 vs. 2×64 per core). If only one logical processor is active in the core, the IDQ can hold 70 uops vs. 64 uops.
- The LSD in the IDQ can detect loops of up to 70 uops per logical processor irrespective single thread or multi thread operation.

2.4.1.2 The Out of Order and Execution Engines

The Out of Order and execution engines changes in Ice Lake Client microarchitecture include:

- A significant increase in size of reorder buffer, load buffer, store buffer, and reservation stations enable deeper OOO execution and higher cache bandwidth.
- Wider machine: 4 → 5 wide allocation, 8 → 10 execution ports.
- Greater capabilities per execution port (e.g., SIMD shuffle, LEA).
- Reduced latency Integer Divider.
- A new iDIV unit was added that significantly reduces the latency and improves the of throughput of integer divide operations.

Table 2-4 summarizes the OOO engine's capability to dispatch different types of operations to ports.

Table 2-4. Dispatch Port and Execution Stacks of the Ice Lake Client Microarchitecture

Port 0	Port 1 ¹	Port 2	Port 3	Port 4	Port 5	Port 6	Port 7	Port 8	Port 9
INT ALU LEA INT Shift Jump1	INT ALU LEA INT Mul INT Div	Load	Load	Store Data	INT ALU LEA INT MUL Hi	INT ALU LEA INT Shift Jump2	Store Address	Store Address	Store Data
FMA Vec ALU Vec Shift FP Div	FMA* Vec ALU* Vec Shift* Vec Shuffle*				Vec ALU Vec Shuffle				

NOTES:

1. "*" in this table indicates these features are not available for 512-bit vectors.

Table 2-5 lists execution units and common representative instructions that rely on these units.

Throughput improvements across the SSE, Intel AVX, and general-purpose instruction sets are related to the number of units for the respective operations, and the varieties of instructions that execute using a particular unit.

Table 2-5. Ice Lake Client Microarchitecture Execution Units and Representative Instructions¹

Execution Unit	# of Unit	Instructions
ALU	4	add, and, cmp, or, test, xor, movzx, movsx, mov, (v)movdqu, (v)movdqa, (v)movap*, (v)movup*
SHFT	2	sal, shl, rol, adc, sarx, adcx, adox, etc.
Slow Int	1	mul, imul, bsr, rcl, shld, mulx, pdep, etc.
BM	2	andn, bextr, blsi, blsmask, bzhi, etc.
Vec ALU	3	(v)pand, (v)por, (v)pxor, (v)movq, (v)movq, (v)movap*, (v)movup*, (v)andp*, (v)orp*, (v)paddb/w/d/q, (v)blendv*, (v)blendp*, (v)pblendd
Vec_Shft	2	(v)psllv*, (v)psrlv*, vector shift count in imm8
Vec Add	2	(v)addp*, (v)cmpp*, (v)max*, (v)min*, (v)padds*, (v)paddus*, (v)psign, (v)pabs, (v)pavgb, (v)pcmpeq*, (v)pmax, (v)cvtps2dq, (v)cvtdq2ps, (v)cvtsd2si, (v)cvts2si
Shuffle	2	(v)shufp*, vperm*, (v)pack*, (v)unpck*, (v)punpck*, (v)pshuf*, (v)pslldq, (v)alignr, (v)pmovzx*, vbroadcast*, (v)pslldq, (v)psrldq, (v)pblendw
Vec Mul	2	(v)mul*, (v)pmul*, (v)pmadd*
SIMD Misc	1	STTNI, (v)pclmulqdq, (v)psadw, vector shift count in xmm
FP Mov	1	(v)movsd/ss, (v)movd gpr
DIVIDE	1	divp*, divs*, vdiv*, sqrt*, vsqrt*, rcp*, vrcp*, rsqrt*, idiv

NOTES:

1. Execution unit mapping to MMX instructions are not covered in this table. See Section 15.16.5 on MMX instruction throughput remedy.

Table 2-6 describes bypass delay in cycles between producer and consumer operations.

Table 2-6. Bypass Delay Between Producer and Consumer Micro-ops

	TO [EU/PORT/Latency]						
FROM [EU/Port/Latency]	SIMD/0,1/1	FMA/0,1/4	VIMUL/0,1/4	SIMD/5/1,3	SHUF/5/1,3	V2I/0/3	I2V/5/1
SIMD/0,1/1	0	1	1	0	0	0	NA
FMA/0,1/4	1	0	1	0	0	0	NA
VIMUL/0,1/4	1	0	1	0	0	0	NA
SIMD/5/1,3	0	1	1	0	0	0	NA
SHUF/5/1,3	0	0	1	0	0	0	NA
V2I/0/3	0	0	1	0	0	0	NA
I2V/5/1	0	1	1	0	0	0	NA

The attributes that are relevant to the producer/consumer micro-ops for bypass are a triplet of abbreviation/one or more port number/latency cycle of the uop. For example:

- "SIMD/0,1/1" applies to 1-cycle vector SIMD uop dispatched to either port 0 or port 1.
- "SIMD/5/1,3" applies to either a 1-cycle or 3-cycle non-shuffle uop dispatched to port 5.
- "V2I/0/3" applies to a 3-cycle vector-to-integer uop dispatched to port 0.
- "I2V/5/1" applies to a 1-cycle integer-to-vector uop to port 5.

2.4.1.3 Cache and Memory Subsystem

The cache hierarchy changes in Ice Lake Client microarchitecture include:

- 50% increase in size of the L1 data cache.
- 2×L1 store bandwidth: 3 → 4 AGUs, 1 → 2 store data.
- Simultaneous handling of more loads and stores enabled by enlarged buffers.
- Higher cache bandwidth compared to previous generations.
- Larger 2nd level TLB: 1.5K entries → 2K entries.
- Enhanced data prefetchers for increased memory parallelism.
- L2 cache size increased from 256KB to 512KB.
- L2 cache associativity increased from 4 ways to 8 ways.
- Significant reduction in effective load latency.

Table 2-7. Cache Parameters of the Ice Lake Client Microarchitecture

Level	Capacity / Associativity	Line Size (bytes)	Latency ¹ (cycles)	Peak Bandwidth (bytes/cycles)	Sustained Bandwidth (bytes/cycles)	Update Policy
First Level (DCU)	48KB/8	64	5	2×64B loads + 1×64B or 2×32B stores	Same as peak	Writeback
Second Level (MLC)	512KB/8	64	13	64	48	Writeback
Third Level (LLC)	Up to 2MB per core/up to 16 ways	64	xx ²	32	21	Writeback

NOTES:

1. Software-visible latency/bandwidth will vary depending on access patterns and other factors.
2. This number depends on core count.

The TLB hierarchy consists of dedicated level one TLB for instruction cache, TLB for L1D, shared L2 TLB for 4K and 4MB pages and a dedicated L2 TLB for 1GB pages.

Table 2-8. TLB Parameters of the Ice Lake Client Microarchitecture

Level	Page Size	Entries ST	Per-thread Entries MT Latency	Associativity
Instruction	4KB	128	64	8
Instruction	2MB/4MB	16	8	8
First Level Data (loads)	4KB	64	64 competitively shared	4
First Level Data (loads)	2MB/4MB	32	32 competitively shared	4
First Level Data (loads)	1GB	8	8 competitively shared	8
First Level Data (stores)	Shared for all page sizes	16	16 competitively shared	16
Second Level	Shared for all page sizes	2048 ¹	2048 competitively shared	16

NOTES:

1. 4K pages can use all 2048 entries. 2/4MB pages can use 1024 entries (in 8 ways), sharing them with 4K pages. 1GB pages can use the other 1024 entries (in 8 ways), also sharing them with 4K pages.

Paired Stores

Ice Lake Client microarchitecture includes two store pipelines in the core, with the following features:

- Two dedicated AGU for LDs on ports 2 and 3.
- Two dedicated AGU for STAs on ports 7 and 8.
- Two fully featured STA pipelines.
- Two 256-bit wide STD pipelines (AVX-512 store data takes two cycles to write).
- Second senior store pipeline to the DCU via store merging.

Ice Lake Client microarchitecture can write two senior stores to the cache in a single cycle if these two stores can be paired together. That is:

- The stores must be to the same cache line.
- Both stores are of the same memory type, WB or USWC.

- None of the stores cross cache line or page boundary.

In order to maximize performance from the second store port try to:

- Align store operations whenever possible.
- Place consecutive stores in the same cache line (not necessarily as adjacent instructions).

As seen in Example 2-6, it is important to take into consideration all stores, explicit or not.

Example 2-6. Considering Stores

Stores are Paired Across Loop Iterations	Stores Not Paired Due to Stack Update in Between
<p>Loop: compute reg ... store [X], reg add X, 4 jmp Loop ; stores from different iterations of the loop can be paired all together because they usually would be same line</p>	<p>Loop: call function to compute reg ... store [X], reg add X, 4 jmp Loop ; stores from different iterations of the loop cannot be paired anymore because of the call store to stack ; the call is disturbing pairing</p>

In some cases it is possible to rearrange the code to achieve store pairing. See the example below for details.

Example 2-7. Rearranging Code to Achieve Store Pairing

Stores to Different Cache Lines - Not Paired	Unrolling May Solve the Problem
<p>Loop: ... compute ymm1 ... vmovaps [x], ymm1 ... compute ymm2 ... vmovaps [y], ymm2 add x, 32 add y, 32 jmp Loop ; this loop cannot pair any store because of alternating store to different cache lines [x] and [y]</p>	<p>Loop: ... compute ymm1 ... vmovaps [x], ymm1 ... compute new ymm1 ... vmovaps [x+32], ymm1 ... compute ymm2 ... vmovaps [y], ymm2 ... compute new ymm2 ... vmovaps [y+32], ymm2 add x, 64 add y, 64 jmp Loop ; the loop was unrolled 2 times and stores re-arranged to make sure two stores to the same cache line are placed one after another. Now stores to addresses [x] and [x+32] are to the same cache line and could be paired together and executed in same cycle</p>

2.4.1.4 New Instructions

New instructions and architectural changes in Ice Lake Client microarchitecture are listed below. Actual support may be product dependent.

- Crypto acceleration
 - SHA NI for acceleration of SHA1 and SHA256 hash algorithms.
 - Big-Number Arithmetic (IFMA): VPMADD52 - two new instructions for big number multiplication for acceleration of RSA vectorized SW and other Crypto algorithms (Public key) performance.

- Galois Field New Instructions (GFNI) for acceleration of various encryption algorithms, error correction algorithms, and bit matrix multiplications.
- Vector AES and Vector Carry-less Multiply (PCLMULQDQ) instructions to accelerate AES and AES-GCM.
- Security Technologies
 - Intel® SGX enhancements to improve usability and applicability: EDMM, multi-package server support, support for VMM memory oversubscription, performance, larger secure memory.
- Sub Page protection for better performance of security VMMs.
- Targeted Acceleration
 - Vector Bit Manipulation Instructions: VBMI1 (permutes, shifts) and VBMI2 (Expand, Compress, Shifts)- used for columnar database access, dictionary based decompression, discrete mathematics, and data-mining routines (bit permutation and bit-matrix-multiplication).
 - VNNI with support for integer 8 and 16 bits data types- CNN/ML/DL acceleration.
 - Bit Algebra (POPCNT, Bit Shuffle).
 - Cache line writeback instruction (CLWB) enables fast cache-line update to memory, while retaining clean copy in cache.
- Platform analysis features for more efficient performance software tuning and debug.
 - AnyThread removal.
 - 2x general counters (up to 8 per-thread).
 - Fixed Counter 3 for issue slots.
 - New performance metrics for built-in support for Level 1 Top-Down method (% of Issue slots that are front-end bound, back-end bound, bad speculation, retiring) while leaving the 8 general purpose counters free for software use.

2.4.1.5 Ice Lake Client Microarchitecture Power Management

Processors based on Ice Lake Client microarchitecture are the first client processors whose cores may execute at a different frequency from one another. The frequency is selected based on the specific instruction mix; the type, width and number of vector instructions of the program that executes on each core, the ratio between active time and idle time of each core, and other considerations such as how many cores share similar characteristics.

Most of the power management features of Skylake Server Microarchitecture (see Section 2.5) is applicable to Ice Lake Client microarchitecture as well. The main differences are the following:

- The typical P0n max frequency difference between Intel® Advanced Vector Extensions (Intel® AVX-512) and Intel® Advanced Vector Extensions 2 (Intel® AVX2) on Ice Lake Client microarchitecture is much lower than on Skylake Server microarchitecture. Therefore, the negative impact on overall application performance is much smaller.
- All processors based on Ice Lake Client microarchitecture contain a single 512-bit FMA unit, whereas some of the processors based on Skylake Server microarchitecture contain two such units. Both processors contain two 256-bit FMA units. The power consumed by Ice Lake Client FMA units is the same, whereas on Skylake Server the 512-bit units consume twice as much.

Compute heavy workloads, especially those that span multiple Ice Lake client cores, execute at a lower frequency than P0n, both under Intel AVX-512 and under Intel AVX2 instruction sets, due to power limitations. In this scenario, Intel AVX-512 architecture, which requires less dynamic instructions to complete the same task than Intel AVX2 architecture, consumes less power and thus may achieve higher frequency. The net result may be higher performance due to the shorter path length and a bit higher frequency.

There are still some cases where coding to the Intel AVX-512 instruction set yields lower performance than when coding to the Intel AVX2 instruction set. Sometimes it is due to microarchitecture artifacts of

longer vectors, in other cases the natural vectors are just not long enough. Most compilers are still maturing their Intel AVX-512 support, and it may take them a few more years to generate optimal code.

The general recommendation in the Skylake Server Power Management section (see Section 2.5.3) still holds. Developers should code to the Intel AVX-512 instruction set and compare the performance to their Intel AVX2 workload on Ice Lake Client microarchitecture, before making the decision to proceed with a complete port.

2.5 SKYLAKE SERVER MICROARCHITECTURE

The Intel® Xeon® Processor Scalable Family is based on the Skylake Server microarchitecture. Processors based on the Skylake microarchitecture can be identified using CPUID's DisplayFamily_DisplayModel signature, which can be found in Table 2-1 of CHAPTER 2 of Intel® 64 and IA-32 Architectures Software Developer's Manual, Volume 4.

The Skylake Server microarchitecture introduces the following new features¹ that allow you to optimize your application for performance and power consumption.

- A new core based on the Skylake Server microarchitecture with process improvements based on the Kaby Lake microarchitecture.
- Intel® Advanced Vector Extensions 512 (Intel® AVX-512) support.
- More cores per socket (max 28 vs. max 22).
- 6 memory channels per socket in Skylake microarchitecture vs. 4 in the Broadwell microarchitecture.
- Bigger L2 cache, smaller non inclusive L3 cache.
- Intel® Optane™ support.
- Intel® Omni-Path Architecture (Intel® OPA).
- Sub-NUMA Clustering (SNC) support.

The green stars in Figure 2-4 represent new features in Skylake Server microarchitecture compared to Skylake microarchitecture for client; a 1MB L2 cache and an additional Intel AVX-512 FMA unit on port 5 which is available on some parts.

Since port 0 and port 1 are 256-bits wide, Intel AVX-512 operations that will be dispatched to port 0 will execute on both port 0 and port 1; however, other operations such as *lea* can still execute on port 1 in parallel. See the red block in Figure 2-8 for the fusion of ports 0 and 1.

Notice that, unlike Skylake microarchitecture for client, the Skylake Server microarchitecture has its front end loop stream detector (LSD) disabled.

1. Some features may not be available on all products.

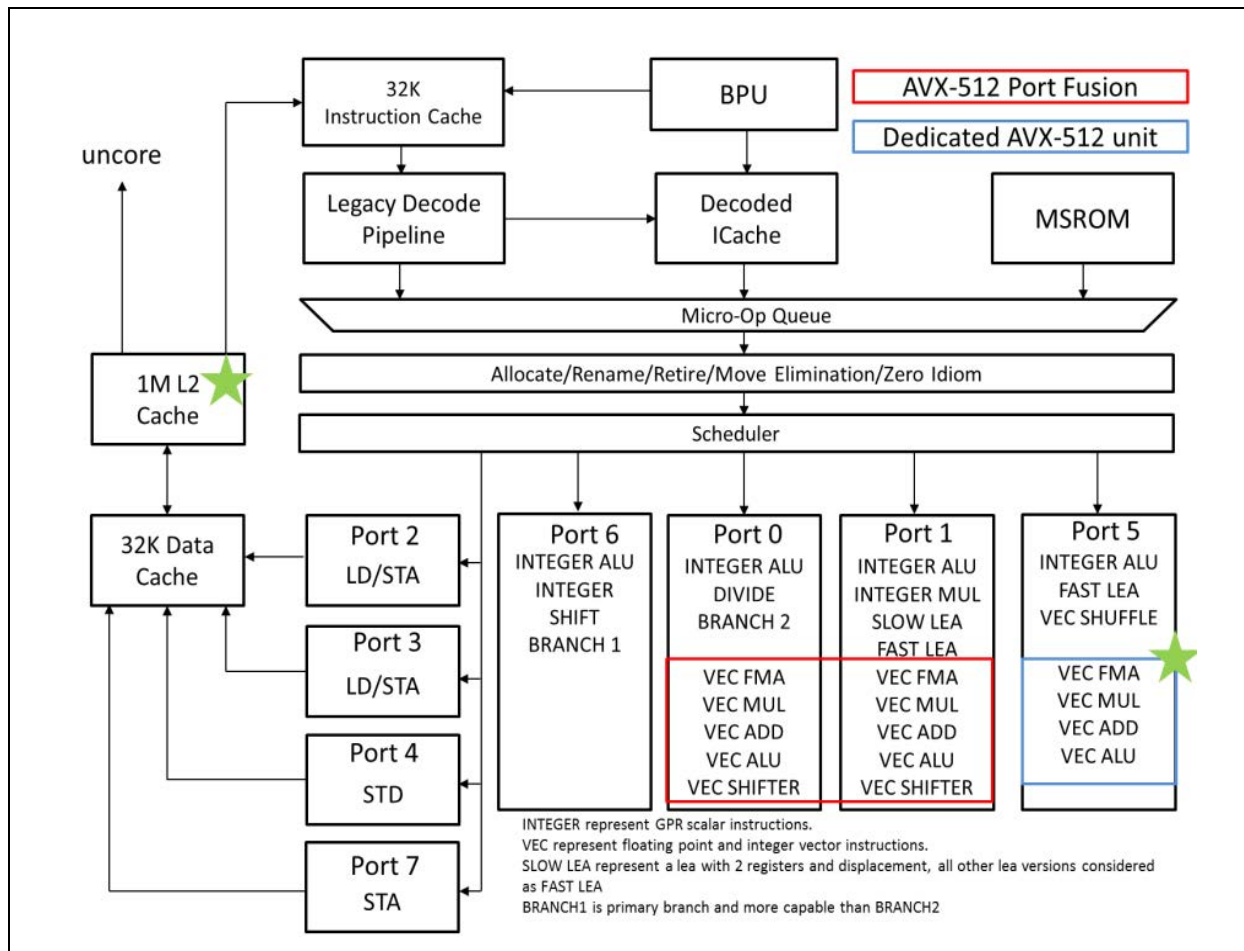

Figure 2-4. Processor Core Pipeline Functionality of the Skylake Server Microarchitecture

2.5.1 Skylake Server Microarchitecture Cache

The Intel Xeon Processor Scalable Family based on Skylake Server microarchitecture has significant changes in core and uncore architecture to improve performance and scalability of several components compared with the previous generation of the Intel Xeon processor family based on Broadwell microarchitecture.

2.5.1.1 Larger Mid-Level Cache

Skylake Server microarchitecture implements a mid-level (L2) cache of 1 MB capacity with a minimum load-to-use latency of 14 cycles. The mid-level cache capacity is four times larger than the capacity in previous Intel Xeon processor family implementations. The line size of the mid-level cache is 64B and it is 16-way associative. The mid-level cache is private to each core.

Software that has been optimized to place data in mid-level cache may have to be revised to take advantage of the larger mid-level cache available in Skylake Server microarchitecture.

2.5.1.2 Non-Inclusive Last Level Cache

The last level cache (LLC) in Skylake is a non-inclusive, distributed, shared cache. The size of each of the banks of last level cache has shrunk to 1.375 MB per bank. Because of the non-inclusive nature of the last level cache, blocks that are present in the mid-level cache of one of the cores may not have a copy resi-

dent in a bank of last level cache. Based on the access pattern, size of the code and data accessed, and sharing behavior between cores for a cache block, the last level cache may appear as a victim cache of the mid-level cache and the aggregate cache capacity per core may appear to be a combination of the private mid-level cache per core and a portion of the last level cache.

2.5.1.3 Skylake Server Microarchitecture Cache Recommendations

A high-level comparison between Skylake Server microarchitecture cache and the previous generation Broadwell microarchitecture cache is available in the table below.

Table 2-9. Cache Comparison Between Skylake Microarchitecture and Broadwell Microarchitecture

Cache level	Category	Broadwell Microarchitecture	Skylake Server Microarchitecture
L1 Data Cache Unit (DCU)	Size [KB]	32	32
	Latency [cycles]	4-6	4-6
	Max bandwidth [bytes/cycles]	96	192
	Sustained bandwidth [bytes/cycles]	93	133
	Associativity [ways]	8	8
L2 Mid-level Cache (MLC)	Size [KB]	256	1024 (1MB)
	Latency [cycles]	12	14
	Max bandwidth [bytes/cycles]	32	64
	Sustained bandwidth [bytes/cycles]	25	52
	Associativity [ways]	8	16
L3 Last-level Cache (LLC)	Size [MB]	Up to 2.5 per core	up to 1.375 ¹ per core
	Latency [cycles]	50-60	50-70
	Max bandwidth [bytes/cycles]	16	32
	Sustained bandwidth [bytes/cycles]	14	15

NOTES:

1. Some Skylake Server parts have some cores disabled and hence have more than 1.375 MB per core of L3 cache.

The figure below shows how Skylake Server microarchitecture shifts the memory balance from shared-distributed with high latency, to private-local with low latency.

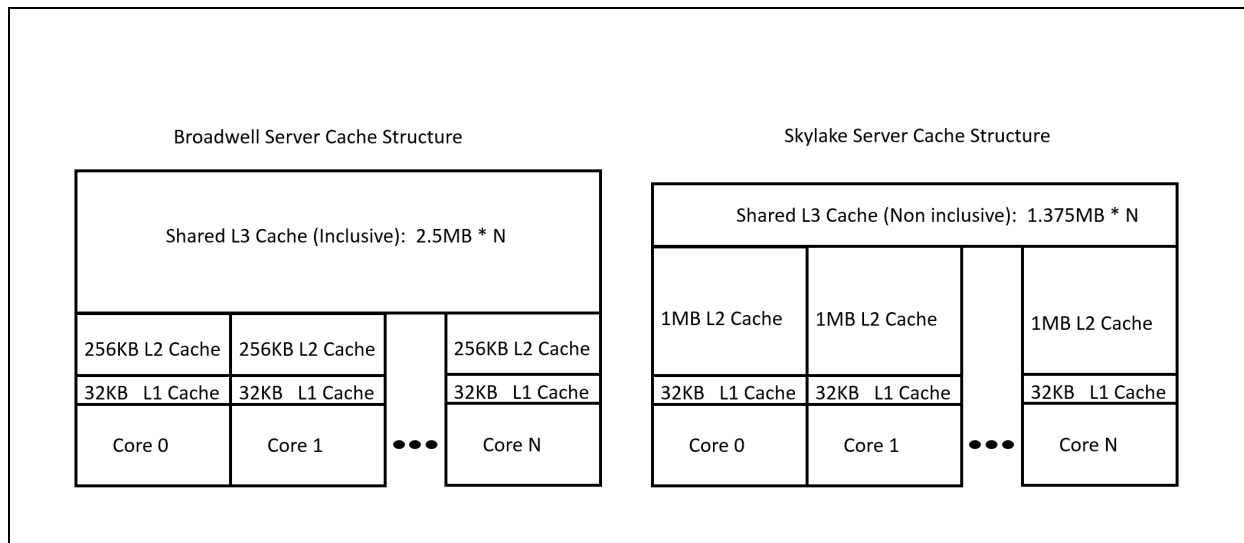

Figure 2-5. Broadwell Microarchitecture and Skylake Server Microarchitecture Cache Structures

The potential performance benefit from the cache changes is high, but software will need to adapt its memory tiling strategy to be optimal for the new cache sizes.

Recommendation: *Rebalance application shared and private data sizes to match the smaller, non-inclusive L3 cache, and larger L2 cache.*

Choice of cache blocking should be based on application bandwidth requirements and changes from one application to another. Having four times the L2 cache size and twice the L2 cache bandwidth compared to the previous generation Broadwell microarchitecture enables some applications to block to L2 instead of L1 and thereby improves performance.

Recommendation: *Consider blocking to L2 on Skylake Server microarchitecture if L2 can sustain the application’s bandwidth requirements.*

The change from inclusive last level cache to non-inclusive means that the capacity of mid-level and last level cache can now be added together. Programs that determine cache capacity per core at run time should now use a combination of mid-level cache size and last level cache size per core to estimate the effective cache size per core. Using just the last level cache size per core may result in non-optimal use of available on-chip cache; see Section 2.5.2 for details.

Recommendation: *In case of no data sharing, applications should consider cache capacity per core as L2 and L3 cache sizes and not only L3 cache size.*

2.5.2 Non-Temporal Stores on Skylake Server Microarchitecture

Because of the change in the size of each bank of last level cache on Skylake Server microarchitecture, if an application, library, or driver only considers the last level cache to determine the size of on-chip cache-per-core, it may see a reduction with Skylake Server microarchitecture and may use non-temporal store with smaller blocks of memory writes. Since non-temporal stores evict cache lines back to memory, this may result in an increase in the number of subsequent cache misses and memory bandwidth demands on Skylake Server microarchitecture, compared to the previous Intel Xeon processor family.

Also, because of a change in the handling of accesses resulting from non-temporal stores by Skylake Server microarchitecture, the resources within each core remain busy for a longer duration compared to similar accesses on the previous Intel Xeon processor family. As a result, if a series of such instructions are executed, there is a potential that the processor may run out of resources and stall, thus limiting the memory write bandwidth from each core.

The increase in cache misses due to overuse of non-temporal stores and the limit on the memory write bandwidth per core for non-temporal stores may result in reduced performance for some applications.

To avoid the performance condition described above with Skylake Server microarchitecture, include mid-level cache capacity per core in addition to the last level cache per core for applications, libraries, or drivers that determine the on-chip cache available with each core. Doing so optimizes the available on-chip cache capacity on Skylake Server microarchitecture as intended, with its non-inclusive last level cache implementation.

2.5.3 Skylake Server Power Management

This section describes the interaction of Skylake Server's Power Management and its Vector ISA.

Skylake Server microarchitecture dynamically selects the frequency at which each of its cores executes. The selected frequency depends on the instruction mix; the type, width, and number of vector instructions that execute over a given period of time. The processor also takes into account the number of cores that share similar characteristics.

Intel® Xeon® processors based on Broadwell microarchitecture work similarly, but to a lesser extent since they only support 256-bit vector instructions. Skylake Server microarchitecture supports Intel® AVX-512 instructions, which can potentially draw more current and more power than Intel® AVX2 instructions.

The processor dynamically adjusts its maximum frequency to higher or lower levels as necessary, therefore a program might be limited to different maximum frequencies during its execution.

Table 2-10 includes information about the maximum Intel® Turbo Boost technology core frequency for each type of instruction executed. The maximum frequency (P0n) is an array of frequencies which depend on the number of cores within the category. The more cores belonging to a category at any given time, the lower the maximum frequency.

Table 2-10. Maximum Intel® Turbo Boost Technology Core Frequency Levels

Level	Category	Frequency Level	Max Frequency (P0n)	Instruction Types
0	Intel® AVX2 light instructions	Highest	Max	Scalar, AVX128, SSE, Intel® AVX2 w/o FP or INT MUL/FMA
1	Intel® AVX2 heavy instructions + Intel® AVX-512 light instructions	Medium	Max Intel® AVX2	Intel® AVX2 FP + INT MUL/FMA, Intel® AVX-512 without FP or INT MUL/FMA
2	Intel® AVX-512 heavy instructions	Lowest	Max Intel® AVX-512	Intel® AVX-512 FP + INT MUL/FMA

For per SKU max frequency details (reference figure 1-15), refer to the Intel® Xeon® Processor Scalable Family Specification Update located here: <https://www.intel.com/content/www/us/en/processors/xeon/scalable/xeon-scalable-spec-update.html>.

Figure 2-6 is an example for core frequency range in a given system where each core frequency is determined independently based on the demand of the workload.

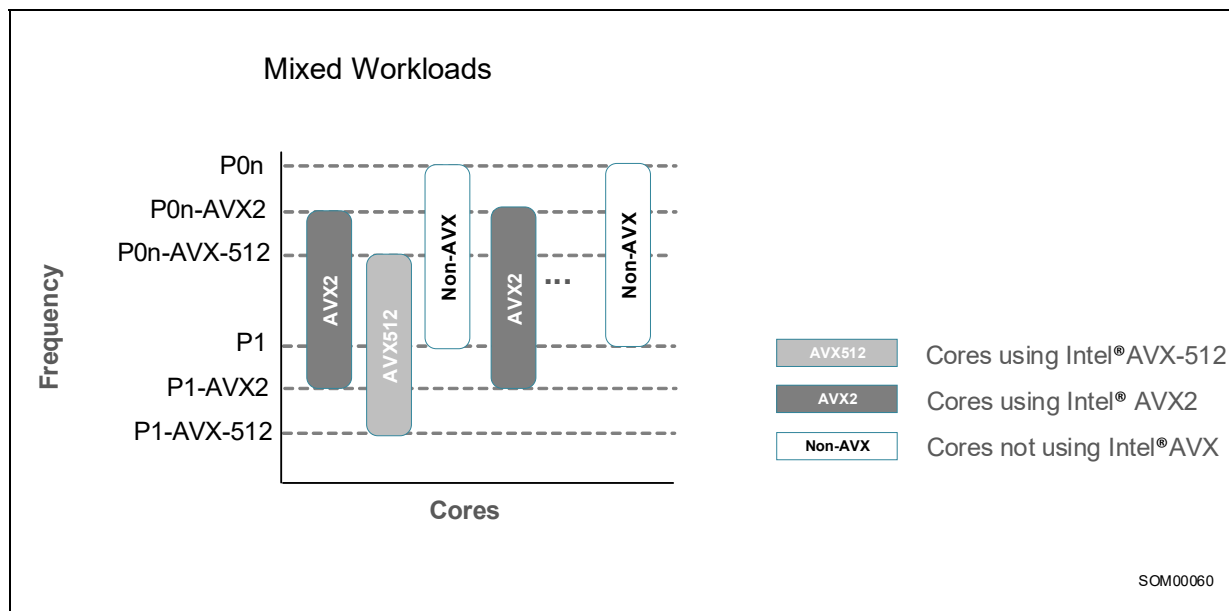

Figure 2-6. Mixed Workloads

The following performance monitoring events can be used to determine how many cycles were spent in each of the three frequency levels.

- CORE_POWER.LVL0_TURBO_LICENSE: Core cycles where the core was running in a manner where the maximum frequency was P0n.
- CORE_POWER.LVL1_TURBO_LICENSE: Core cycles where the core was running in a manner where the maximum frequency was P0n-AVX2.
- CORE_POWER.LVL2_TURBO_LICENSE: Core cycles where the core was running in a manner where the maximum frequency was P0n-AVX-512.

When the core requests a higher license level than its current one, it takes the PCU up to 500 micro-seconds to grant the new license. Until then the core operates at a lower peak capability. During this time period the PCU evaluates how many cores are executing at the new license level and adjusts their frequency as necessary, potentially lowering the frequency. Cores that execute at other license levels are not affected.

A timer of approximately 2ms is applied before going back to a higher frequency level. Any condition that would have requested a new license resets the timer.

NOTES

A license transition request may occur when executing instructions on a mis-speculated path.

A large enough mix of Intel AVX-512 light instructions and Intel AVX2 heavy instructions drives the core to request License 2, despite the fact that they usually map to License 1. The same is true for Intel AVX2 light instructions and Intel SSE heavy instructions that may drive the core to License 1 rather than License 0. For example, The Intel® Xeon® Platinum 8180 processor moves from license 1 to license 2 when executing a mix of 110 Intel AVX-512 light instructions and 20 256-bit heavy instructions over a window of 65 cycles.

Some workloads do not cause the processor to reach its maximum frequency as these workloads are bound by other factors. For example, the LINPACK benchmark is power limited and does not reach the processor's maximum frequency. The following graph shows how frequency degrades as vector width grows, but, despite the frequency drop, performance improves. The data for this graph was collected on an Intel Xeon Platinum 8180 processor.

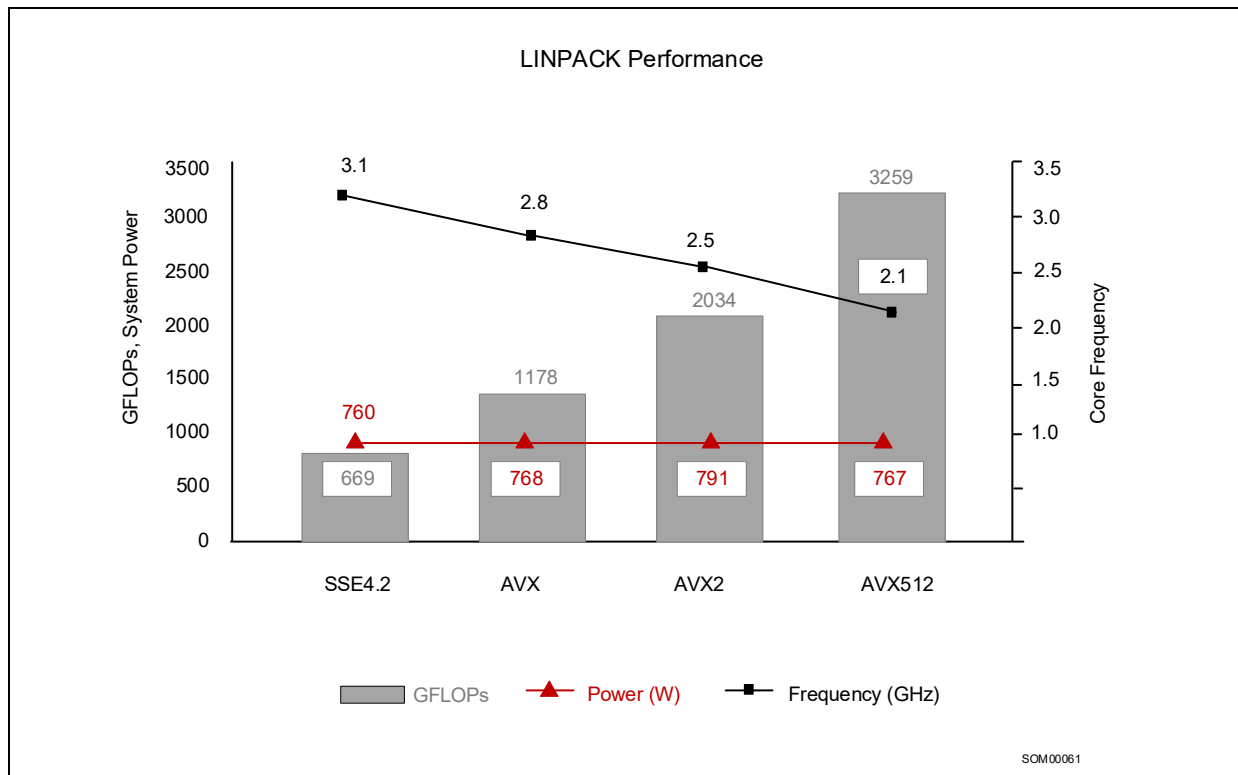

Figure 2-7. LINPACK Performance

Workloads that execute Intel AVX-512 instructions as a large proportion of their whole instruction count can gain performance compared to Intel AVX2 instructions, even though they may operate at a lower frequency. For example, maximum frequency bound Deep Learning workloads that target Intel AVX-512 heavy instructions at a very high percentage can gain 1.3x-1.5x performance improvement vs. the same workload built to target Intel AVX2 (both operating on Skylake Server microarchitecture).

It is not always easy to predict whether a program's performance will improve from building it to target Intel AVX-512 instructions. Programs that enjoy high performance gains from the use of xmm or ymm registers may expect performance improvement by moving to the use of zmm registers. However, some programs that use zmm registers may not gain as much, or may even lose performance. It is recommended to try multiple build options and measure the performance of the program.

Recommendation: To identify the optimal compiler options to use, build the application with each of the following set of options and choose the set that provides the best performance.

- `-xCORE-AVX2 -mtune=skylake-avx512` (Linux* and macOS*)
`/QxCORE-AVX2 /tune=skylake-avx512` (Windows*)
- `-xCORE-AVX512 -qopt-zmm-usage=low` (Linux* and macOS*)
`/QxCORE-AVX512 /Qopt-zmm-usage:low` (Windows*)
- `-xCORE-AVX512 -qopt-zmm-usage=high` (Linux* and macOS*)
`/QxCORE-AVX512 /Qopt-zmm-usage:high` (Windows*)

See Section 18.26, "CLDEMOTEMOTE" for more information about these options.

The GCC Compiler has the option `-mprefer-vector-width=none|128|256|512` to control vector width preference. While `-march=skylake-avx512` is designed to provide the best performance for the Skylake Server microarchitecture some programs can benefit from different vector width preferences. To identify the optimal compiler options to use, build the application with each of the following set of options and choose the set that provides the best performance. `-mprefer-vector-width=256` is the default for `skylake-avx512`.

- `-march=skylake -mtune=skylake-avx512`
- `-march=skylake-avx512`
- `-march=skylake-avx512 -mprefer-vector-width=512`

Clang/LLVM is currently implementing the option `-mprefer-vector-width=none|128|256|512`, similar to GCC. To identify the optimal compiler options to use, build the application with each of the following set of options and choose the set that provides the best performance.

- `-march=skylake -mtune=skylake-avx512`
- `-march=skylake-avx512` (plus `-mprefer-vector-width=256`, if available)
- `-march=skylake-avx512` (plus `-mprefer-vector-width=512`, if available)

2.6 SKYLAKE CLIENT MICROARCHITECTURE

The Skylake Client microarchitecture builds on the successes of the Haswell and Broadwell microarchitectures. The basic pipeline functionality of the Skylake Client microarchitecture is depicted in Figure 2-8.

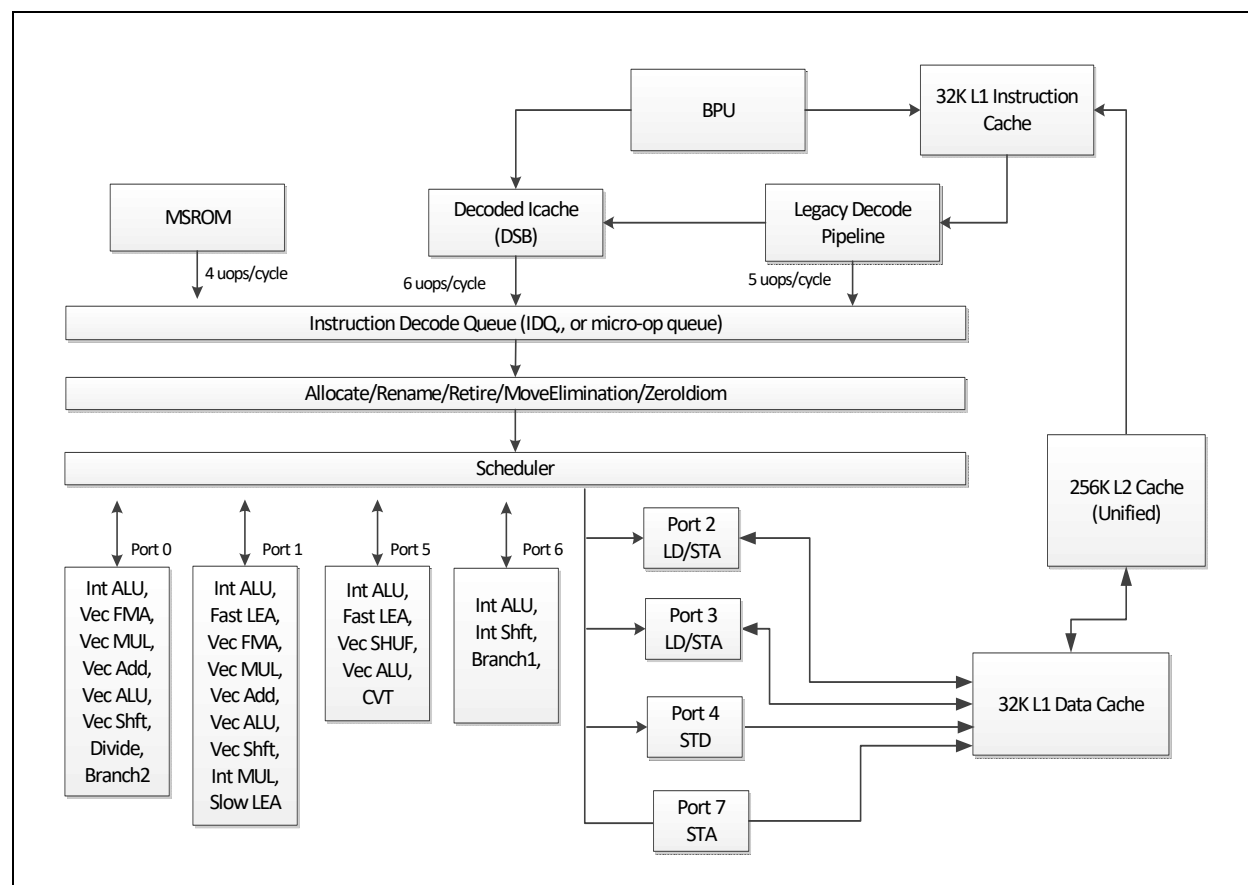

Figure 2-8. CPU Core Pipeline Functionality of the Skylake Client Microarchitecture

The Skylake Client microarchitecture offers the following enhancements:

- Larger internal buffers to enable deeper OOO execution and higher cache bandwidth.
- Improved front end throughput.
- Improved branch predictor.
- Improved divider throughput and latency.
- Lower power consumption.
- Improved SMT performance with Hyper-Threading Technology.
- Balanced floating-point ADD, MUL, FMA throughput and latency.

The microarchitecture supports flexible integration of multiple processor cores with a shared uncore subsystem consisting of a number of components including a ring interconnect to multiple slices of L3 (an off-die L4 is optional), processor graphics, integrated memory controller, interconnect fabrics, etc. A four-core configuration can be supported similar to the arrangement shown in Appendix E, “Earlier Generations of Intel® 64 and IA-32 Processor Architectures,” Figure E-2.

2.6.1 The Front End

The front end in the Skylake Client microarchitecture provides the following improvements over previous generation microarchitectures:

- Legacy Decode Pipeline delivery of 5 uops per cycle to the IDQ compared to 4 uops in previous generations.
- The DSB delivers 6 uops per cycle to the IDQ compared to 4 uops in previous generations.
- The IDQ can hold 64 uops per logical processor vs. 28 uops per logical processor in previous generations when two sibling logical processors in the same core are active (2x64 vs. 2x28 per core). If only one logical processor is active in the core, the IDQ can hold 64 uops (64 vs. 56 uops in ST operation).
- The LSD in the IDQ can detect loops up to 64 uops per logical processor irrespective ST or SMT operation.
- Improved Branch Predictor.

2.6.2 The Out-of-Order Execution Engine

The Out of Order and execution engine changes in Skylake Client microarchitecture include:

- Larger buffers enable deeper OOO execution compared to previous generations.
- Improved throughput and latency for divide/sqrt and approximate reciprocals.
- Identical latency and throughput for all operations running on FMA units.
- Longer pause latency enables better power efficiency and better SMT performance resource utilization.

Table 2-11 summarizes the OOO engine’s capability to dispatch different types of operations to various ports.

Table 2-11. Dispatch Port and Execution Stacks of the Skylake Client Microarchitecture

Port 0	Port 1	Port 2, 3	Port 4	Port 5	Port 6	Port 7
ALU, Vec ALU	ALU, Fast LEA, Vec ALU	LD STA	STD	ALU, Fast LEA, Vec ALU,	ALU, Shft,	STA
Vec Shft, Vec Add,	Vec Shft, Vec Add,			Vec Shuffle,	Branch1	
Vec Mul, FMA,	Vec Mul, FMA					
DIV,	Slow Int					
Branch2	Slow LEA					

Table 2-12 lists execution units and common representative instructions that rely on these units. Throughput improvements across the SSE, AVX and general-purpose instruction sets are related to the number of units for the respective operations, and the varieties of instructions that execute using a particular unit.

Table 2-12. Skylake Client Microarchitecture Execution Units and Representative Instructions¹

Execution Unit	# of Unit	Instructions
ALU	4	add, and, cmp, or, test, xor, movzx, movsx, mov, (v)movdqu, (v)movdqa, (v)movap*, (v)movup*
SHFT	2	sal, shl, rol, adc, sarx, adcx, adox, etc.
Slow Int	1	mul, imul, bsr, rcl, shld, mulx, pdep, etc.
BM	2	andn, bextr, blsi, blsmk, bzhi, etc
Vec ALU	3	(v)pand, (v)por, (v)pxor, (v)movq, (v)movq, (v)movap*, (v)movup*, (v)andp*, (v)orp*, (v)paddb/w/d/q, (v)blendv*, (v)blendp*, (v)pblendd
Vec_Shft	2	(v)psllv*, (v)psrlv*, vector shift count in imm8
Vec Add	2	(v)addp*, (v)cmpp*, (v)max*, (v)min*, (v)padds*, (v)paddus*, (v)psign, (v)pabs, (v)pavgb, (v)pcmpeq*, (v)pmax, (v)cvtps2dq, (v)cvtdq2ps, (v)cvtsd2si, (v)cvts2si
Shuffle	1	(v)shufp*, vperm*, (v)pack*, (v)unpck*, (v)punpck*, (v)pshuf*, (v)pslldq, (v)alignr, (v)pmovzx*, vbroadcast*, (v)pslldq, (v)psrldq, (v)pblendw
Vec Mul	2	(v)mul*, (v)pmul*, (v)pmadd*,
SIMD Misc	1	STTNI, (v)pclmulqdq, (v)psadw, vector shift count in xmm,
FP Mov	1	(v)movsd/ss, (v)movd gpr,
DIVIDE	1	divp*, divs*, vdiv*, sqrt*, vsqrt*, rcp*, vrcp*, rsqrt*, idiv

NOTES:

1. Execution unit mapping to MMX instructions are not covered in this table. See Section 15.16.5 on MMX instruction throughput remedy.

A significant portion of the SSE, AVX and general-purpose instructions also have latency improvements. Appendix C lists the specific details. Software-visible latency exposure of an instruction sometimes may include additional contributions that depend on the relationship between micro-ops flows of the producer instruction and the micro-op flows of the ensuing consumer instruction. For example, a two-uop instruction like VPMULLD may experience two cumulative bypass delays of 1 cycle each from each of the two micro-ops of VPMULLD.

Table 2-13 describes the bypass delay in cycles between a producer uop and the consumer uop. The left-most column lists a variety of situations characteristic of the producer micro-op. The top row lists a variety of situations characteristic of the consumer micro-op.

Table 2-13. Bypass Delay Between Producer and Consumer Micro-ops

	SIMD/0,1/1	FMA/0,1/4	VIMUL/0,1/4	SIMD/5/1,3	SHUF/5/1,3	V2I/0/3	I2V/5/1
SIMD/0,1/1	0	1	1	0	0	0	NA
FMA/0,1/4	1	0	1	0	0	0	NA
VIMUL/0,1/4	1	0	1	0	0	0	NA
SIMD/5/1,3	0	1	1	0	0	0	NA
SHUF/5/1,3	0	0	1	0	0	0	NA
V2I/0/3	NA	NA	NA	NA	NA	NA	NA
I2V/5/1	0	0	1	0	0	0	NA

The attributes that are relevant to the producer/consumer micro-ops for bypass are a triplet of abbreviation/one or more port number/latency cycle of the uop. For example:

- “SIMD/0,1/1” applies to 1-cycle vector SIMD uop dispatched to either port 0 or port 1.
- “VIMUL/0,1/4” applies to 4-cycle vector integer multiply uop dispatched to either port 0 or port 1.
- “SIMD/5/1,3” applies to either 1-cycle or 3-cycle non-shuffle uop dispatched to port 5.

2.6.3 Cache and Memory Subsystem

The cache hierarchy of the Skylake Client microarchitecture has the following enhancements:

- Higher Cache bandwidth compared to previous generations.
- Simultaneous handling of more loads and stores enabled by enlarged buffers.
- Processor can do two page walks in parallel compared to one in Haswell microarchitecture and earlier generations.
- Page split load penalty down from 100 cycles in previous generation to 5 cycles.
- L3 write bandwidth increased from 4 cycles per line in previous generation to 2 per line.
- Support for the CLFLUSHOPT instruction to flush cache lines and manage memory ordering of flushed data using SFENCE.
- Reduced performance penalty for a software prefetch that specifies a NULL pointer.
- L2 associativity changed from 8 ways to 4 ways.

Table 2-14. Cache Parameters of the Skylake Client Microarchitecture

Level	Capacity / Associativity	Line Size (bytes)	Fastest Latency ¹	Peak Bandwidth (bytes/cyc)	Sustained Bandwidth (bytes/cyc)	Update Policy
First Level Data	32 KB/ 8	64	4 cycle	96 (2x32B Load + 1*32B Store)	~81	Writeback
Instruction	32 KB/8	64	N/A	N/A	N/A	N/A
Second Level	256KB/4	64	12 cycle	64	~29	Writeback
Third Level (Shared L3)	Up to 2MB per core/Up to 16 ways	64	⁴⁴	32	~18	Writeback

NOTES:

1. Software-visible latency will vary depending on access patterns and other factors.

The TLB hierarchy consists of dedicated level one TLB for instruction cache, TLB for L1D, plus unified TLB for L2. The partition column of Table 2-15 indicates the resource sharing policy when Hyper-Threading Technology is active.

Table 2-15. TLB Parameters of the Skylake Client Microarchitecture

Level	Page Size	Entries	Associativity	Partition
Instruction	4KB	128	8 ways	dynamic
Instruction	2MB/4MB	8 per thread		fixed
First Level Data	4KB	64	4	fixed
First Level Data	2MB/4MB	32	4	fixed
First Level Data	1GB	4	4	fixed
Second Level	Shared by 4KB and 2/4MB pages	1536	12	fixed
Second Level	1GB	16	4	fixed

2.6.4 Pause Latency in Skylake Client Microarchitecture

The PAUSE instruction is typically used with software threads executing on two logical processors located in the same processor core, waiting for a lock to be released. Such short wait loops tend to last between tens and a few hundreds of cycles, so performance-wise it is better to wait while occupying the CPU than yielding to the OS. When the wait loop is expected to last for thousands of cycles or more, it is preferable to yield to the operating system by calling an OS synchronization API function, such as WaitForSingleObject on Windows* OS or futex on Linux.

The PAUSE instruction is intended to:

- Temporarily provide the sibling logical processor (ready to make forward progress exiting the spin loop) with competitively shared hardware resources. The competitively-shared microarchitectural resources that the sibling logical processor can utilize in the Skylake Client microarchitecture are listed below.
 - Front end slots in the Decode ICache, LSD and IDQ.
 - Execution slots in the RS.
- Save power consumed by the processor core compared with executing equivalent spin loop instruction sequence in the following configurations.
 - One logical processor is inactive (e.g., entering a C-state).
 - Both logical processors in the same core execute the PAUSE instruction.

- HT is disabled (e.g. using BIOS options).

The latency of the PAUSE instruction in prior generation microarchitectures is about 10 cycles, whereas in Skylake Client microarchitecture it has been extended to as many as 140 cycles.

The increased latency (allowing more effective utilization of competitively-shared microarchitectural resources to the logical processor ready to make forward progress) has a small positive performance impact of 1-2% on highly threaded applications. It is expected to have negligible impact on less threaded applications if forward progress is not blocked executing a fixed number of looped PAUSE instructions. There's also a small power benefit in 2-core and 4-core systems.

As the PAUSE latency has been increased significantly, workloads that are sensitive to PAUSE latency will suffer some performance loss.

The following is an example of how to use the PAUSE instruction with a dynamic loop iteration count.

Notice that in the Skylake Client microarchitecture the RDTSC instruction counts at the machine's guaranteed P1 frequency independently of the current processor clock (see the INVARIANT TSC property), and therefore, when running in Intel® Turbo-Boost-enabled mode, the delay will remain constant, but the number of instructions that could have been executed will change.

■ Use Poll Delay function in your lock to wait a given amount of guaranteed P1 frequency cycles, specified in the "clocks" variable.

Example 2-8. Dynamic Pause Loop Example

```
#include <x86intrin.h>
#include <stdint.h>

/* A useful predicate for dealing with timestamps that may wrap.
Is a before b? Since the timestamps may wrap, this is asking whether it's
shorter to go clockwise from a to b around the clock-face, or anti-clockwise.
Times where going clockwise is less distance than going anti-clockwise
are in the future, others are in the past. e.g. a = MAX-1, b = MAX+1 (=0),
then a > b (true) does not mean a reached b; whereas signed(a) = -2,
signed(b) = 0 captures the actual difference */

static inline bool before(uint64_t a, uint64_t b)
{
    return ((int64_t)b - (int64_t)a) > 0;
}

void pollDelay(uint32_t clocks)
{
    uint64_t endTime = _rdtsc() + clocks;

    for (; before(_rdtsc(), endTime); )
        _mm_pause();
}
```

For contended spinlocks of the form shown in the baseline example below, we recommend an exponential back off when the lock is found to be busy, as shown in the improved example, to avoid significant performance degradation that can be caused by conflicts between threads in the machine. This is more important as we increase the number of threads in the machine and make changes to the architecture that might aggravate these conflict conditions. In multi-socket Intel server processors with shared memory, conflicts across threads take much longer to resolve as the number of threads contending for the same lock increases. The exponential back off is designed to avoid these conflicts between the threads thus avoiding the potential performance degradation. Note that in the example below, the

number of PAUSE instructions are increased by a factor of 2 until some MAX_BACKOFF is reached which is subject to tuning.

Example 2-9. Contended Locks with Increasing Back-off Example

```

/*****/
/*Baseline Version */
/*****/

// atomic {if (lock == free) then change lock state to busy}
while (cmpxchg(lock, free, busy) == fail)
{
    while (lock == busy)
    {
        __asm__ ("pause");
    }
}

```

```

/*****/
/*Improved Version */
/*****/

int mask = 1;
int const max = 64; //MAX_BACKOFF
while (cmpxchg(lock, free, busy) == fail)
{
    while (lock == busy)
    {
        for (int i=mask; i--){
            __asm__ ("pause");
        }
        mask = mask < max ? mask<<1 : max;
    }
}

```

2.7 INTEL® HYPER-THREADING TECHNOLOGY

Intel® Hyper-Threading Technology (HT Technology) enables software to take advantage of task-level, or thread-level parallelism by providing multiple logical processors within a physical processor package, or within each processor core in a physical processor package. In its first implementation in the Intel Xeon processor, Hyper-Threading Technology makes a single physical processor (or a processor core) appear as two or more logical processors. Intel Xeon Phi processors based on the Knights Landing microarchitecture support 4 logical processors in each processor core; see Chapter 23 for detailed information of Hyper-Threading Technology that is implemented in the Knights Landing microarchitecture.

Most Intel Architecture processor families support Hyper-Threading Technology with two logical processors in each processor core, or in a physical processor in early implementations. The rest of this section describes features of the early implementation of Hyper-Threading Technology. Most of the descriptions also apply to later Hyper-Threading Technology implementations supporting two logical processors. The microarchitecture sections in this chapter provide additional details to individual microarchitecture and enhancements to Hyper-Threading Technology.

The two logical processors each have a complete set of architectural registers while sharing one single physical processor's resources. By maintaining the architecture state of two processors, an HT Tech-

nology capable processor looks like two processors to software, including operating system and application code.

By sharing resources needed for peak demands between two logical processors, HT Technology is well suited for multiprocessor systems to provide an additional performance boost in throughput when compared to traditional MP systems.

Figure 2-9 shows a typical bus-based symmetric multiprocessor (SMP) based on processors supporting HT Technology. Each logical processor can execute a software thread, allowing a maximum of two software threads to execute simultaneously on one physical processor. The two software threads execute simultaneously, meaning that in the same clock cycle an “add” operation from logical processor 0 and another “add” operation and load from logical processor 1 can be executed simultaneously by the execution engine.

In the first implementation of HT Technology, the physical execution resources are shared and the architecture state is duplicated for each logical processor. This minimizes the die area cost of implementing HT Technology while still achieving performance gains for multithreaded applications or multitasking workloads.

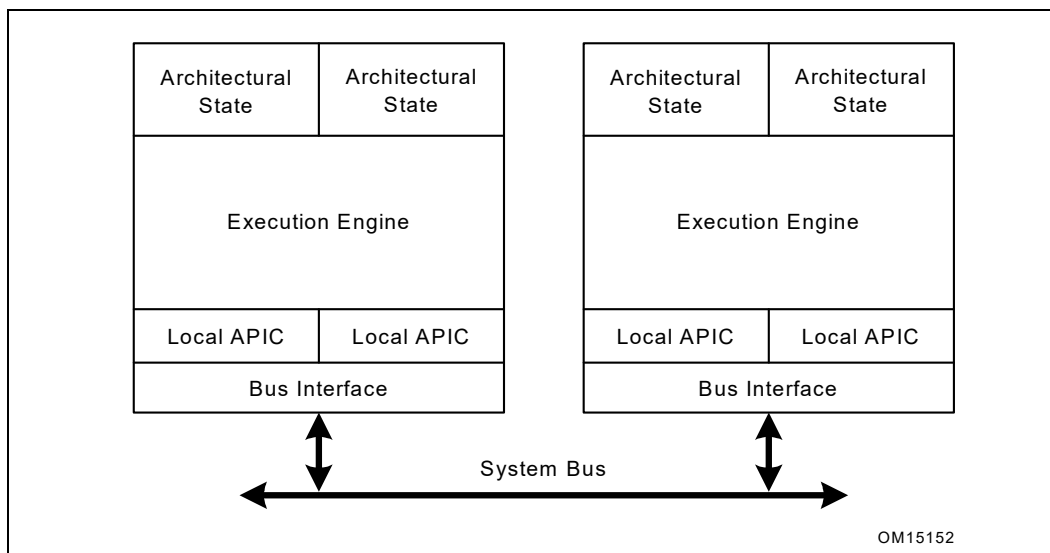

Figure 2-9. Hyper-Threading Technology on an SMP

The performance potential due to HT Technology is due to:

- The fact that operating systems and user programs can schedule processes or threads to execute simultaneously on the logical processors in each physical processor.
- The ability to use on-chip execution resources at a higher level than when only a single thread is consuming the execution resources; higher level of resource utilization can lead to higher system throughput.

2.7.1 Processor Resources and HT Technology

The majority of microarchitecture resources in a physical processor are shared between the logical processors. Only a few small data structures were replicated for each logical processor. This section describes how resources are shared, partitioned or replicated.

2.7.1.1 Replicated Resources

The architectural state is replicated for each logical processor. The architecture state consists of registers that are used by the operating system and application code to control program behavior and store data for computations. This state includes the eight general-purpose registers, the control registers, machine state registers, debug registers, and others. There are a few exceptions, most notably the memory type range registers (MTRRs) and the performance monitoring resources. For a complete list of the architecture state and exceptions, see the Intel® 64 and IA-32 Architectures Software Developer's Manual, Volumes 3A, 3B, 3C & 3D.

Other resources such as instruction pointers and register renaming tables were replicated to simultaneously track execution and state changes of the two logical processors. The return stack predictor is replicated to improve branch prediction of return instructions.

In addition, a few buffers (for example, the 2-entry instruction streaming buffers) were replicated to reduce complexity.

2.7.1.2 Partitioned Resources

Several buffers are shared by limiting the use of each logical processor to half the entries. These are referred to as partitioned resources. Reasons for this partitioning include:

- Operational fairness.
- Permitting the ability to allow operations from one logical processor to bypass operations of the other logical processor that may have stalled.

For example: a cache miss, a branch misprediction, or instruction dependencies may prevent a logical processor from making forward progress for some number of cycles. The partitioning prevents the stalled logical processor from blocking forward progress.

In general, the buffers for staging instructions between major pipe stages are partitioned. These buffers include μ op queues after the execution trace cache, the queues after the register rename stage, the reorder buffer which stages instructions for retirement, and the load and store buffers.

In the case of load and store buffers, partitioning also provided an easier implementation to maintain memory ordering for each logical processor and detect memory ordering violations.

2.7.1.3 Shared Resources

Most resources in a physical processor are fully shared to improve the dynamic utilization of the resource, including caches and all the execution units. Some shared resources which are linearly addressed, like the DTLB, include a logical processor ID bit to distinguish whether the entry belongs to one logical processor or the other.

2.7.2 Microarchitecture Pipeline and HT Technology

This section describes the HT Technology microarchitecture and how instructions from the two logical processors are handled between the front end and the back end of the pipeline.

Although instructions originating from two programs or two threads execute simultaneously and not necessarily in program order in the execution core and memory hierarchy, the front end and back end contain several selection points to select between instructions from the two logical processors. All selection points alternate between the two logical processors unless one logical processor cannot make use of a pipeline stage. In this case, the other logical processor has full use of every cycle of the pipeline stage. Reasons why a logical processor may not use a pipeline stage include cache misses, branch mispredictions, and instruction dependencies.

2.7.3 Execution Core

The core can dispatch up to six μ ops per cycle, provided the μ ops are ready to execute. Once the μ ops are placed in the queues waiting for execution, there is no distinction between instructions from the two logical processors. The execution core and memory hierarchy is also oblivious to which instructions belong to which logical processor.

After execution, instructions are placed in the re-order buffer. The re-order buffer decouples the execution stage from the retirement stage. The re-order buffer is partitioned such that each uses half the entries.

2.7.4 Retirement

The retirement logic tracks when instructions from the two logical processors are ready to be retired. It retires the instruction in program order for each logical processor by alternating between the two logical processors. If one logical processor is not ready to retire any instructions, then all retirement bandwidth is dedicated to the other logical processor.

Once stores have retired, the processor needs to write the store data into the level-one data cache. Selection logic alternates between the two logical processors to commit store data to the cache.

2.8 SIMD TECHNOLOGY

SIMD computations (see Figure 2-10) were introduced to the architecture with MMX technology. MMX technology allows SIMD computations to be performed on packed byte, word, and doubleword integers. The integers are contained in a set of eight 64-bit registers called MMX registers (see Figure 2-11).

The Pentium III processor extended the SIMD computation model with the introduction of the Streaming SIMD Extensions (SSE). SSE allows SIMD computations to be performed on operands that contain four packed single-precision floating-point data elements. The operands can be in memory or in a set of eight 128-bit XMM registers (see Figure 2-11). SSE also extended SIMD computational capability by adding additional 64-bit MMX instructions.

Figure 2-10 shows a typical SIMD computation. Two sets of four packed data elements (X1, X2, X3, and X4, and Y1, Y2, Y3, and Y4) are operated on in parallel, with the same operation being performed on each corresponding pair of data elements (X1 and Y1, X2 and Y2, X3 and Y3, and X4 and Y4). The results of the four parallel computations are sorted as a set of four packed data elements.

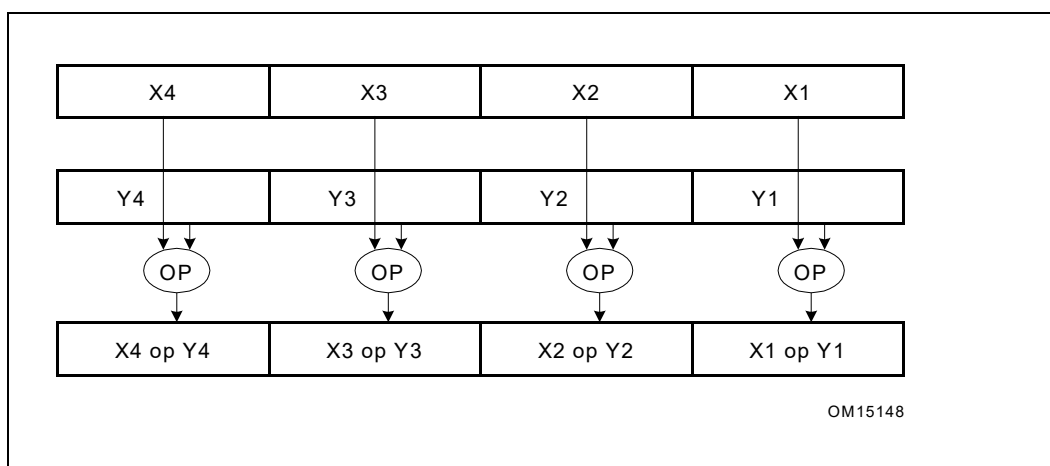

Figure 2-10. Typical SIMD Operations

The Pentium 4 processor further extended the SIMD computation model with the introduction of Streaming SIMD Extensions 2 (SSE2), Streaming SIMD Extensions 3 (SSE3), and Intel Xeon processor 5100 series introduced Supplemental Streaming SIMD Extensions 3 (SSSE3).

SSE2 works with operands in either memory or in the XMM registers. The technology extends SIMD computations to process packed double-precision floating-point data elements and 128-bit packed integers. There are 144 instructions in SSE2 that operate on two packed double-precision floating-point data elements or on 16 packed byte, 8 packed word, 4 doubleword, and 2 quadword integers.

SSE3 enhances x87, SSE and SSE2 by providing 13 instructions that can accelerate application performance in specific areas. These include video processing, complex arithmetics, and thread synchronization. SSE3 complements SSE and SSE2 with instructions that process SIMD data asymmetrically, facilitate horizontal computation, and help avoid loading cache line splits. See Figure 2-11.

SSSE3 provides additional enhancement for SIMD computation with 32 instructions on digital video and signal processing.

SSE4.1, SSE4.2 and AESNI are additional SIMD extensions that provide acceleration for applications in media processing, text/lexical processing, and block encryption/decryption.

The SIMD extensions operates the same way in Intel 64 architecture as in IA-32 architecture, with the following enhancements:

- 128-bit SIMD instructions referencing XMM register can access 16 XMM registers in 64-bit mode.
- Instructions that reference 32-bit general purpose registers can access 16 general purpose registers in 64-bit mode.

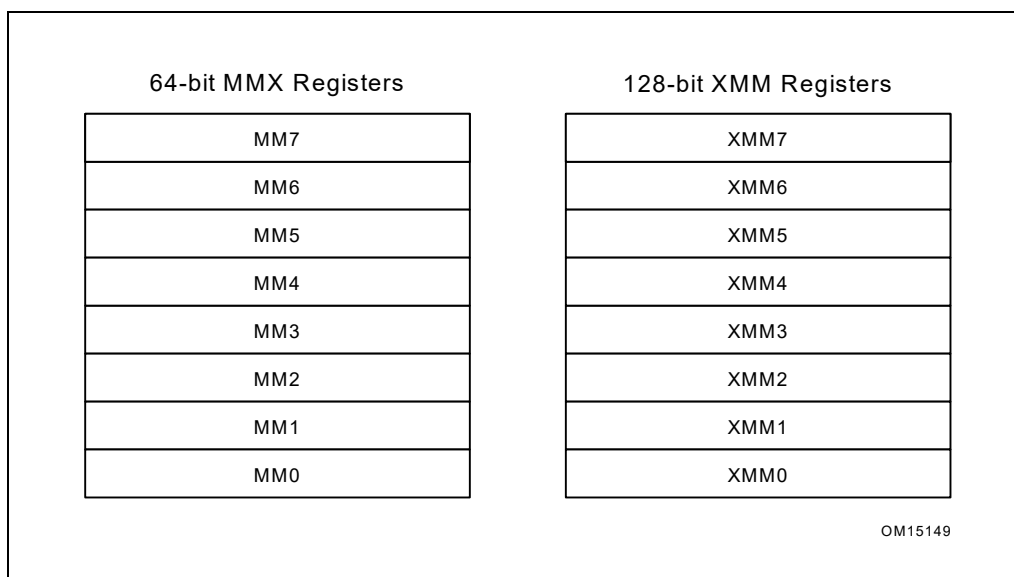

Figure 2-11. SIMD Instruction Register Usage

SIMD improves the performance of 3D graphics, speech recognition, image processing, scientific applications and applications that have the following characteristics:

- Inherently parallel.
- Recurring memory access patterns.
- Localized recurring operations performed on the data.
- Data-independent control flow.

2.9 SUMMARY OF SIMD TECHNOLOGIES AND APPLICATION LEVEL EXTENSIONS

SIMD floating-point instructions fully support the IEEE Standard 754 for Binary Floating-Point Arithmetic. They are accessible from all IA-32 execution modes: protected mode, real address mode, and Virtual 8086 mode.

SSE, SSE2, and MMX technologies are architectural extensions. Existing software will continue to run correctly, without modification on Intel microprocessors that incorporate these technologies. Existing software will also run correctly in the presence of applications that incorporate SIMD technologies.

SSE and SSE2 instructions also introduced cacheability and memory ordering instructions that can improve cache usage and application performance.

For more on SSE, SSE2, SSE3 and MMX technologies, see the following chapters in the *Intel® 64 and IA-32 Architectures Software Developer's Manual, Volume 1*:

- Chapter 9, "Programming with Intel® MMX™ Technology."
- Chapter 10, "Programming with Streaming SIMD Extensions (SSE)."
- Chapter 11, "Programming with Streaming SIMD Extensions 2 (SSE2)."
- Chapter 12, "Programming with Intel® SSE3, SSSE3, Intel® SSE4 AND Intel® AESNI."
- Chapter 14, "Programming with AVX, FMA and AVX2."
- Chapter 15, "Programming with Intel® AVX-512."
- Chapter 16, "Programming with Intel® Transactional Synchronization Extensions."

2.9.1 MMX™ Technology

MMX Technology introduced:

- 64-bit MMX registers.
- Support for SIMD operations on packed byte, word, and doubleword integers.

Recommendation: Integer SIMD code written using MMX instructions should consider more efficient implementations using SSE/Intel AVX instructions.

2.9.2 Streaming SIMD Extensions

Streaming SIMD extensions introduced:

- 128-bit XMM registers.
- 128-bit data type with four packed single-precision floating-point operands.
- Data prefetch instructions.
- Non-temporal store instructions and other cacheability and memory ordering instructions.
- Extra 64-bit SIMD integer support.

SSE instructions are useful for 3D geometry, 3D rendering, speech recognition, and video encoding and decoding.

2.9.3 Streaming SIMD Extensions 2

Streaming SIMD extensions 2 add the following:

- 128-bit data type with two packed double-precision floating-point operands.
- 128-bit data types for SIMD integer operation on 16-byte, 8-word, 4-doubleword, or 2-quadword integers.
- Support for SIMD arithmetic on 64-bit integer operands.

- Instructions for converting between new and existing data types.
- Extended support for data shuffling.
- Extended support for cacheability and memory ordering operations.

SSE2 instructions are useful for 3D graphics, video decoding/encoding, and encryption.

2.9.4 Streaming SIMD Extensions 3

Streaming SIMD extensions 3 add the following:

- SIMD floating-point instructions for asymmetric and horizontal computation.
- A special-purpose 128-bit load instruction to avoid cache line splits.
- An x87 FPU instruction to convert to integer independent of the floating-point control word (FCW).
- Instructions to support thread synchronization.

SSE3 instructions are useful for scientific, video and multi-threaded applications.

2.9.5 Supplemental Streaming SIMD Extensions 3

The Supplemental Streaming SIMD Extensions 3 introduces 32 new instructions to accelerate eight types of computations on packed integers. These include:

- 12 instructions that perform horizontal addition or subtraction operations.
- 6 instructions that evaluate the absolute values.
- 2 instructions that perform multiply and add operations and speed up the evaluation of dot products.
- 2 instructions that accelerate packed-integer multiply operations and produce integer values with scaling.
- 2 instructions that perform a byte-wise, in-place shuffle according to the second shuffle control operand.
- 6 instructions that negate packed integers in the destination operand if the signs of the corresponding element in the source operand is less than zero.
- 2 instructions that align data from the composite of two operands.

2.9.6 SSE4.1

SSE4.1 introduces 47 new instructions to accelerate video, imaging and 3D applications. SSE4.1 also improves compiler vectorization and significantly increase support for packed dword computation. These include:

- Two instructions perform packed dword multiplies.
- Two instructions perform floating-point dot products with input/output selects.
- One instruction provides a streaming hint for WC loads.
- Six instructions simplify packed blending.
- Eight instructions expand support for packed integer MIN/MAX.
- Four instructions support floating-point round with selectable rounding mode and precision exception override.
- Seven instructions improve data insertion and extractions from XMM registers
- Twelve instructions improve packed integer format conversions (sign and zero extensions).
- One instruction improves SAD (sum absolute difference) generation for small block sizes.
- One instruction aids horizontal searching operations of word integers.
- One instruction improves masked comparisons.

- One instruction adds qword packed equality comparisons.
- One instruction adds dword packing with unsigned saturation.

2.9.7 SSE4.2

SSE4.2 introduces 7 new instructions. These include:

- A 128-bit SIMD integer instruction for comparing 64-bit integer data elements.
- Four string/text processing instructions providing a rich set of primitives, these primitives can accelerate:
 - Basic and advanced string library functions from `strlen`, `strcmp`, to `strcspn`.
 - Delimiter processing, token extraction for lexing of text streams.
 - Parser, schema validation including XML processing.
- A general-purpose instruction for accelerating cyclic redundancy checksum signature calculations.
- A general-purpose instruction for calculating bit count population of integer numbers.

2.9.8 AESNI and PCLMULQDQ

AESNI introduces 7 new instructions, six of them are primitives for accelerating algorithms based on AES encryption/decryption standard, referred to as AESNI.

The PCLMULQDQ instruction accelerates general-purpose block encryption, which can perform carry-less multiplication for two binary numbers up to 64-bit wide.

Typically, algorithm based on AES standard involve transformation of block data over multiple iterations via several primitives. The AES standard supports cipher key of sizes 128, 192, and 256 bits. The respective cipher key sizes correspond to 10, 12, and 14 rounds of iteration.

AES encryption involves processing 128-bit input data (plain text) through a finite number of iterative operation, referred to as "AES round", into a 128-bit encrypted block (ciphertext). Decryption follows the reverse direction of iterative operation using the "equivalent inverse cipher" instead of the "inverse cipher".

The cryptographic processing at each round involves two input data, one is the "state", the other is the "round key". Each round uses a different "round key". The round keys are derived from the cipher key using a "key schedule" algorithm. The "key schedule" algorithm is independent of the data processing of encryption/decryption, and can be carried out independently from the encryption/decryption phase.

The AES extensions provide two primitives to accelerate AES rounds on encryption, two primitives for AES rounds on decryption using the equivalent inverse cipher, and two instructions to support the AES key expansion procedure.

2.9.9 Intel® Advanced Vector Extensions

Intel® Advanced Vector Extensions offers comprehensive architectural enhancements over previous generations of Streaming SIMD Extensions. Intel AVX introduces the following architectural enhancements:

- Support for 256-bit wide vectors and SIMD register set.
- 256-bit floating-point instruction set enhancement with up to 2X performance gain relative to 128-bit Streaming SIMD extensions.
- Instruction syntax support for generalized three-operand syntax to improve instruction programming flexibility and efficient encoding of new instruction extensions.
- Enhancement of legacy 128-bit SIMD instruction extensions to support three-operand syntax and to simplify compiler vectorization of high-level language expressions.

- Support flexible deployment of 256-bit AVX code, 128-bit AVX code, legacy 128-bit code and scalar code.

Intel AVX instruction set and 256-bit register state management detail are described in Intel® 64 and IA-32 Architectures Software Developer's Manual, Volumes 2A, 2B, 2C & 2D. Optimization techniques for Intel AVX are discussed in Chapter 15, "Optimizations for Intel® AVX, FMA and AVX2."

2.9.10 Half-Precision Floating-Point Conversion (F16C)

VCVTPH2PS and VCVTPS2PH are two instructions supporting half-precision floating-point data type conversion to and from single-precision floating-point data types. These two instruction extends on the same programming model as Intel AVX.

2.9.11 RDRAND

The RDRAND instruction retrieves a random number supplied by a cryptographically secure, deterministic random bit generator (DRBG). The DRBG is designed to meet NIST SP 800-90A standard.

2.9.12 Fused-Multiply-ADD (FMA) Extensions

FMA extensions enhances Intel AVX with high-throughput, arithmetic capabilities covering fused multiply-add, fused multiply-subtract, fused multiply add/subtract interleave, signed-reversed multiply on fused multiply-add and multiply-subtract operations. FMA extensions provide 36 256-bit floating-point instructions to perform computation on 256-bit vectors and additional 128-bit and scalar FMA instructions.

2.9.13 Intel AVX2

Intel AVX2 extends Intel AVX by promoting most of the 128-bit SIMD integer instructions with 256-bit numeric processing capabilities. AVX2 instructions follow the same programming model as AVX instructions.

In addition, AVX2 provide enhanced functionalities for broadcast/permute operations on data elements, vector shift instructions with variable-shift count per data element, and instructions to fetch non-contiguous data elements from memory.

2.9.14 General-Purpose Bit-Processing Instructions

The fourth generation Intel Core processor family introduces a collection of bit processing instructions that operate on the general purpose registers. The majority of these instructions uses the VEX-prefix encoding scheme to provide non-destructive source operand syntax.

These instructions are enumerated by three separate feature flags reported by CPUID. For details, see Section 5.1 of Intel® 64 and IA-32 Architectures Software Developer's Manual, Volume 1 and chapters 3, 4 and 5 of the Intel® 64 and IA-32 Architectures Software Developer's Manual, Volumes 2A, 2B, 2C & 2D.

2.9.15 Intel® Transactional Synchronization Extensions

The fourth generation Intel Core processor family introduces Intel® Transactional Synchronization Extensions (Intel TSX), which aim to improve the performance of lock-protected critical sections of multi-threaded applications while maintaining the lock-based programming model.

For background and details, see Chapter 16, "Programming with Intel® Transactional Synchronization Extensions" of Intel® 64 and IA-32 Architectures Software Developer's Manual, Volume 1.

Software tuning recommendations for using Intel TSX on lock-protected critical sections of multithreaded applications are described in Chapter 16, “Intel® TSX Recommendations.”

2.9.16 RDSEED

The RDSEED instruction retrieves a random number supplied by a cryptographically secure, enhanced deterministic random bit generator Enhanced NRBG). The NRBG is designed to meet the NIST SP 800-90B and NIST SP 800-90C standards.

2.9.17 ADCX and ADOX Instructions

The ADCX and ADOX instructions, in conjunction with MULX instruction, enable software to speed up calculations that require large integer numerics. Details can be found at <http://www.intel.com/content/dam/www/public/us/en/documents/white-papers/large-integer-squaring-ia-paper.pdf>.

CHAPTER 3

GENERAL OPTIMIZATION GUIDELINES

This chapter discusses general optimization techniques that can improve the performance of applications running on Intel® processors. These techniques take advantage of microarchitectural features described in Chapter 2, “Intel® 64 and IA-32 Processor Architectures.” Optimization guidelines focusing on Intel multi-core processors, Hyper-Threading Technology, and 64-bit mode applications are discussed in Chapter 11, “Multicore and Hyper-Threading Technology,” and Chapter 13, “64-bit Mode Coding Guidelines.”

Practices that optimize performance focus on three areas:

- Tools and techniques for code generation.
- Analysis of the performance characteristics of the workload and its interaction with microarchitectural sub-systems.
- Tuning code to the target microarchitecture (or families of microarchitecture) to improve performance.

Some hints on using tools are summarized first to simplify the first two tasks. The rest of the chapter will focus on recommendations for code generation or code tuning to the target microarchitectures.

This chapter explains optimization techniques for the Intel® C++ Compiler, the Intel® Fortran Compiler, and other compilers.

3.1 PERFORMANCE TOOLS

Intel offers several tools to help optimize application performance, including compilers, performance analysis, and multithreading tools.

3.1.1 Intel® C++ and Fortran Compilers

Intel compilers support multiple operating systems (Windows*, Linux*, Mac OS*, and embedded). The Intel compilers optimize performance and give application developers access to advanced features, including:

- Flexibility to target 32-bit or 64-bit Intel processors for optimization
- Compatibility with many integrated development environments or third-party compilers.
- Automatic optimization features to take advantage of the target processor’s architecture.
- Automatic compiler optimization reduces the need to write different code for different processors.
- Common compiler features that are supported across Windows, Linux, and Mac OS include:
 - General optimization settings.
 - Cache-management features.
 - Interprocedural optimization (IPO) methods.
 - Profile-guided optimization (PGO) methods.
 - Multithreading support.
 - Floating-point arithmetic precision and consistency support.
 - Compiler optimization and vectorization reports.

3.1.2 General Compiler Recommendations

Generally speaking, a compiler tuned for a target microarchitecture can be expected to match or outperform hand-coding. However, if performance problems are noted with the compiled code, some compilers (like Intel C++ and Fortran compilers) allow the coder to insert intrinsics or inline assembly to exert control over generated code. If inline assembly is used, the user must verify that the code generated is high quality and yields good performance.

Default compiler switches are targeted for common cases. An optimization may be made to the compiler default if it benefits most programs. If the root cause of a performance problem is a poor choice on the part of the compiler, using different switches or compiling the targeted module with a different compiler may be the solution. See the “Quick Reference Guide to Optimization with Intel C++ and Fortran Compilers” for additional suggestions on compiler Optimization Options, including processor-specific ones.

3.1.3 VTune™ Performance Analyzer

VTune uses performance monitoring hardware to collect statistics and coding information about your application and its interaction with the microarchitecture. This allows software engineers to measure performance characteristics of the workload for a given microarchitecture. VTune supports all current and past Intel processor families.

The VTune Performance Analyzer provides two kinds of feedback:

- Indication of a performance improvement gained by using a specific coding recommendation or microarchitectural feature.
- Information on whether a change in the program has improved or degraded performance with respect to a particular metric.

The VTune Performance Analyzer also provides measures for a number of workload characteristics, including:

- Retirement throughput of instruction execution as an indication of the degree of extractable instruction-level parallelism in the workload.
- Data traffic locality as an indication of the stress point of the cache and memory hierarchy.
- Data traffic parallelism as an indication of the degree of effectiveness of amortization of data access latency.

NOTE

Improving performance in one part of the machine does not necessarily bring significant gains to overall performance. It is possible to degrade overall performance by improving performance for some particular metric.

Where appropriate, coding recommendations in this chapter include descriptions of the VTune Performance Analyzer events that provide measurable data on the performance gain achieved by following the recommendations. For more on using the VTune analyzer, refer to the application’s online help.

3.2 PROCESSOR PERSPECTIVES

Many coding recommendations work well across current microarchitectures. However, there are situations where a recommendation may benefit one microarchitecture more than another.

3.2.1 CPUID Dispatch Strategy and Compatible Code Strategy

When optimum performance on all processor generations is desired, applications can take advantage of the CPUID instruction to identify the processor generation and integrate processor-specific instructions

into the source code. The Intel C++ Compiler supports the integration of different versions of the code for different target processors. The selection of which code to execute at runtime is made based on the CPU identifiers. Binary code targeted for different processor generations can be generated under the control of the programmer or by the compiler. Refer to the Intel® C++ Compiler 19.0 Developer Guide and reference `cpu_dispatch` and `cpu_specific` sections for more information on CPU dispatching (a.k.a function multi-versioning).

For applications that target multiple generations of microarchitectures, and where minimum binary code size and single code path is important, a compatible code strategy is the best. Optimizing applications using techniques developed for the Intel Core microarchitecture combined with Nehalem microarchitecture are likely to improve code efficiency and scalability when running on processors based on current and future generations of Intel 64 and IA-32 processors.

3.2.2 Transparent Cache-Parameter Strategy

If the CPUID instruction supports function leaf 4, also known as deterministic cache parameter leaf, the leaf reports cache parameters for each level of the cache hierarchy in a deterministic and forward-compatible manner across Intel 64 and IA-32 processor families.

For coding techniques that rely on specific parameters of a cache level, using the deterministic cache parameter allows software to implement techniques in a way that is forward-compatible with future generations of Intel 64 and IA-32 processors, and cross-compatible with processors equipped with different cache sizes.

3.2.3 Threading Strategy and Hardware Multithreading Support

Intel 64 and IA-32 processor families offer hardware multithreading support in two forms: multi-core technology and HT Technology.

To fully harness the performance potential of hardware multithreading in current and future generations of Intel 64 and IA-32 processors, software must embrace a threaded approach in application design. At the same time, to address the widest range of installed machines, multithreaded software should be able to run without failure on a single processor without hardware multithreading support and should achieve performance on a single logical processor that is comparable to an unthreaded implementation (if such comparison can be made). This generally requires architecting a multithreaded application to minimize the overhead of thread synchronization. Additional guidelines on multithreading are discussed in Chapter 11, “Multicore and Hyper-Threading Technology.”

3.3 CODING RULES, SUGGESTIONS AND TUNING HINTS

This section includes rules, suggestions, and hints. They are targeted for engineers who are:

- Modifying source code to enhance performance (user/source rules).
- Writing assemblers or compilers (assembly/compiler rules).
- Doing detailed performance tuning (tuning suggestions).

Coding recommendations are ranked in importance using two measures:

- Local impact (high, medium, or low) refers to a recommendation’s affect on the performance of a given instance of code.
- Generality (high, medium, or low) measures how often such instances occur across all application domains. Generality may also be thought of as “frequency”.

These recommendations are approximate. They can vary depending on coding style, application domain, and other factors.

The purpose of the high, medium, and low (H, M, and L) priorities is to suggest the relative level of performance gain one can expect if a recommendation is implemented.

Because it is not possible to predict the frequency of a particular code instance in applications, priority hints cannot be directly correlated to application-level performance gain. In cases in which application-level performance gain has been observed, we have provided a quantitative characterization of the gain (for information only). In cases in which the impact has been deemed inapplicable, no priority is assigned.

3.4 OPTIMIZING THE FRONT END

Optimizing the front end covers two aspects:

- Maintaining steady supply of micro-ops to the execution engine — Mispredicted branches can disrupt streams of micro-ops, or cause the execution engine to waste execution resources on executing streams of micro-ops in the non-architected code path. Much of the tuning in this respect focuses on working with the Branch Prediction Unit. Common techniques are covered in Section 3.4.1, “Branch Prediction Optimization.”
- Supplying streams of micro-ops to utilize the execution bandwidth and retirement bandwidth as much as possible — For Intel Core microarchitecture and Intel Core Duo processor family, this aspect focuses maintaining high decode throughput. In Sandy Bridge microarchitecture, this aspect focuses on keeping the hot code running from Decoded ICache. Techniques to maximize decode throughput for Intel Core microarchitecture are covered in Section 3.4.2, “Fetch and Decode Optimization.”

3.4.1 Branch Prediction Optimization

Branch optimizations have a significant impact on performance. By understanding the flow of branches and improving their predictability, you can increase the speed of code significantly.

Optimizations that help branch prediction are:

- Keep code and data on separate pages. This is very important; see Section 3.6, “Optimizing Memory Accesses,” for more information.
- Eliminate branches whenever possible.
- Arrange code to be consistent with the static branch prediction algorithm.
- Use the PAUSE instruction in spin-wait loops.
- Inline functions and pair up calls and returns.
- Unroll as necessary so that repeatedly-executed loops have sixteen or fewer iterations (unless this causes an excessive code size increase).
- Avoid putting multiple conditional branches in the same 8-byte aligned code block (i.e, have their last bytes' addresses within the same 8-byte aligned code) if the lower 6 bits of their target IPs are the same. This restriction has been removed in Ice Lake Client and later microarchitectures.

3.4.1.1 Eliminating Branches

Eliminating branches improves performance because:

- It reduces the possibility of mispredictions.
- It reduces the number of required branch target buffer (BTB) entries. Conditional branches that are never taken do not consume BTB resources.

There are four principal ways of eliminating branches:

- Arrange code to make basic blocks contiguous.
- Unroll loops, as discussed in Section 3.4.1.6, “Loop Unrolling.”
- Use the CMOV instruction.
- Use the SETCC instruction.

The following rules apply to branch elimination:

Assembly/Compiler Coding Rule 1. (MH impact, M generality) Arrange code to make basic blocks contiguous and eliminate unnecessary branches.

Assembly/Compiler Coding Rule 2. (M impact, ML generality) Use the SETCC and CMOV instructions to eliminate unpredictable conditional branches where possible. Do not do this for predictable branches. Do not use these instructions to eliminate all unpredictable conditional branches (because using these instructions will incur execution overhead due to the requirement for executing both paths of a conditional branch). In addition, converting a conditional branch to SETCC or CMOV trades off control flow dependence for data dependence and restricts the capability of the out-of-order engine. When tuning, note that all Intel 64 and IA-32 processors usually have very high branch prediction rates. Consistently mispredicted branches are generally rare. Use these instructions only if the increase in computation time is less than the expected cost of a mispredicted branch.

Consider a line of C code that has a condition dependent upon one of the constants:

```
X = (A < B) ? CONST1 : CONST2;
```

This code conditionally compares two values, A and B. If the condition is true, X is set to CONST1; otherwise it is set to CONST2. An assembly code sequence equivalent to the above C code can contain branches that are not predictable if there are no correlation in the two values.

Example 3-1 shows the assembly code with unpredictable branches. The unpredictable branches can be removed with the use of the SETCC instruction. Example 3-2 shows optimized code that has no branches.

Example 3-1. Assembly Code with an Unpredictable Branch

```

cmp a, b           ; Condition
jbe L30           ; Conditional branch
mov ebx, const1   ; ebx holds X
jmp L31           ; Unconditional branch
L30:
  mov ebx, const2
L31:
```

Example 3-2. Code Optimization to Eliminate Branches

```

xor  ebx, ebx     ; Clear ebx (X in the C code)
cmp  A, B
setge bl          ; When ebx = 0 or 1
                    ; OR the complement condition
sub  ebx, 1       ; ebx=11...11 or 00...00
and  ebx, CONST3 ; CONST3 = CONST1-CONST2
add  ebx, CONST2 ; ebx=CONST1 or CONST2
```

The optimized code in Example 3-2 sets EBX to zero, then compares A and B. If A is greater than or equal to B, EBX is set to one. Then EBX is decreased and AND'd with the difference of the constant values. This sets EBX to either zero or the difference of the values. By adding CONST2 back to EBX, the correct value is written to EBX. When CONST2 is equal to zero, the last instruction can be deleted.

Another way to remove branches is to use the CMOV and FCMOV instructions. Example 3-3 shows how to change a TEST and branch instruction sequence using CMOV to eliminate a branch. If the TEST sets the equal flag, the value in EBX will be moved to EAX. This branch is data-dependent, and is representative of an unpredictable branch.

Example 3-3. Eliminating Branch with CMOV Instruction

```

test ecx, ecx
jne 1H
mov eax, ebx

1H:
; To optimize code, combine jne and mov into one cmovcc instruction that checks the equal flag
test ecx, ecx ; Test the flags
cmoveq eax, ebx ; If the equal flag is set, move
; ebx to eax- the 1H: tag no longer needed

```

An extension to this concept can be seen in the AVX-512 masked operations, as well as in some instructions such as VPCMP which can be used to eliminate data dependent branches; see Section 18.4.

3.4.1.2 Static Prediction

Branches that do not have a history in the BTB (see Section 3.4.1, “Branch Prediction Optimization”) are predicted using a static prediction algorithm:

- Predict forward conditional branches to be NOT taken.
- Predict backward conditional branches to be taken.
- Predict indirect branches to be NOT taken.

The following rule applies to static prediction:

Assembly/Compiler Coding Rule 3. (M impact, H generality) Arrange code to be consistent with the static branch prediction algorithm: make the fall-through code following a conditional branch be the likely target for a branch with a forward target, and make the fall-through code following a conditional branch be the unlikely target for a branch with a backward target.

Example 3-4 illustrates the static branch prediction algorithm. The body of an IF-THEN conditional is predicted.

Example 3-4. Static Branch Prediction Algorithm

```

//Forward condition branches not taken (fall through)
IF<condition> {...
↓
}

IF<condition> {...
↓
}

//Backward conditional branches are taken
LOOP {...
↑ — }<condition>

//Unconditional branches taken
JMP
----->

```

Example 3-5 and Example 3-6 provide basic rules for a static prediction algorithm. In Example 3-5, the backward branch (JC BEGIN) is not in the BTB the first time through; therefore, the BTB does not issue

a prediction. The static predictor, however, will predict the branch to be taken, so a misprediction will not occur.

Example 3-5. Static Taken Prediction

```
Begin: mov    eax, mem32
       and    eax, ebx
       imul   eax, edx
       shld   eax, 7
       jc     Begin
```

The first branch instruction (JC BEGIN) in Example 3-6 is a conditional forward branch. It is not in the BTB the first time through, but the static predictor will predict the branch to fall through. The static prediction algorithm correctly predicts that the CALL CONVERT instruction will be taken, even before the branch has any branch history in the BTB.

Example 3-6. Static Not-Taken Prediction

```
       mov    eax, mem32
       and    eax, ebx
       imul   eax, edx
       shld   eax, 7
       jc     Begin
       mov    eax, 0
Begin: call   Convert
```

The Intel Core microarchitecture does not use the static prediction heuristic. However, to maintain consistency across Intel 64 and IA-32 processors, software should maintain the static prediction heuristic as the default.

3.4.1.3 Inlining, Calls and Returns

The return address stack mechanism augments the static and dynamic predictors to optimize specifically for calls and returns. It holds 16 entries, which is large enough to cover the call depth of most programs. If there is a chain of more than 16 nested calls and more than 16 returns in rapid succession, performance may degrade.

To enable the use of the return stack mechanism, calls and returns must be matched in pairs. If this is done, the likelihood of exceeding the stack depth in a manner that will impact performance is very low.

The following rules apply to inlining, calls, and returns:

Assembly/Compiler Coding Rule 4. (MH impact, MH generality) *Near calls must be matched with near returns, and far calls must be matched with far returns. Pushing the return address on the stack and jumping to the routine to be called is not recommended since it creates a mismatch in calls and returns.*

Calls and returns are expensive; use inlining for the following reasons:

- Parameter passing overhead can be eliminated.
- In a compiler, inlining a function exposes more opportunity for optimization.
- If the inlined routine contains branches, the additional context of the caller may improve branch prediction within the routine.
- A mispredicted branch can lead to performance penalties inside a small function that are larger than those that would occur if that function is inlined.

Assembly/Compiler Coding Rule 5. (MH impact, MH generality) *Selectively inline a function if doing so decreases code size or if the function is small and the call site is frequently executed.*

Assembly/Compiler Coding Rule 6. (ML impact, ML generality) *If there are more than 16 nested calls and returns in rapid succession; consider transforming the program with inline to reduce the call depth.*

Assembly/Compiler Coding Rule 7. (ML impact, ML generality) *Favor inlining small functions that contain branches with poor prediction rates. If a branch misprediction results in a RETURN being prematurely predicted as taken, a performance penalty may be incurred.*

Assembly/Compiler Coding Rule 8. (L impact, L generality) *If the last statement in a function is a call to another function, consider converting the call to a jump. This will save the call/return overhead as well as an entry in the return stack buffer.*

Assembly/Compiler Coding Rule 9. (M impact, L generality) *Do not put more than four branches in a 16-byte chunk.*

Assembly/Compiler Coding Rule 10. (M impact, L generality) *Do not put more than two end loop branches in a 16-byte chunk.*

3.4.1.4 Code Alignment

Careful arrangement of code can enhance cache and memory locality. Likely sequences of basic blocks should be laid out contiguously in memory. This may involve removing unlikely code, such as code to handle error conditions, from the sequence. See Section 3.7, "Prefetching," on optimizing the instruction prefetcher.

Assembly/Compiler Coding Rule 11. (M impact, H generality) *When executing code from the Decoded ICache, direct branches that are mostly taken should have all their instruction bytes in a 64B cache line and nearer the end of that cache line. Their targets should be at or near the beginning of a 64B cache line.*

When executing code from the legacy decode pipeline, direct branches that are mostly taken should have all their instruction bytes in a 16B aligned chunk of memory and nearer the end of that 16B aligned chunk. Their targets should be at or near the beginning of a 16B aligned chunk of memory.

Assembly/Compiler Coding Rule 12. (M impact, H generality) *If the body of a conditional is not likely to be executed, it should be placed in another part of the program. If it is highly unlikely to be executed and code locality is an issue, it should be placed on a different code page.*

3.4.1.5 Branch Type Selection

The default predicted target for indirect branches and calls is the fall-through path. Fall-through prediction is overridden if and when a hardware prediction is available for that branch. The predicted branch target from branch prediction hardware for an indirect branch is the previously executed branch target.

The default prediction to the fall-through path is only a significant issue if no branch prediction is available, due to poor code locality or pathological branch conflict problems. For indirect calls, predicting the fall-through path is usually not an issue, since execution will likely return to the instruction after the associated return.

Placing data immediately following an indirect branch can cause a performance problem. If the data consists of all zeros, it looks like a long stream of ADDs to memory destinations and this can cause resource conflicts and slow down branch recovery. Also, data immediately following indirect branches may appear as branches to the branch predication hardware, which can branch off to execute other data pages. This can lead to subsequent self-modifying code problems.

Assembly/Compiler Coding Rule 13. (M impact, L generality) *When indirect branches are present, try to put the most likely target of an indirect branch immediately following the indirect branch. Alternatively, if indirect branches are common but they cannot be predicted by branch prediction hardware, then follow the indirect branch with a UD2 instruction, which will stop the processor from decoding down the fall-through path.*

Indirect branches resulting from code constructs (such as switch statements, computed GOTOs or calls through pointers) can jump to an arbitrary number of locations. If the code sequence is such that the

target destination of a branch goes to the same address most of the time, then the BTB will predict accurately most of the time. Since only one taken (non-fall-through) target can be stored in the BTB, indirect branches with multiple taken targets may have lower prediction rates.

The effective number of targets stored may be increased by introducing additional conditional branches. Adding a conditional branch to a target is fruitful if:

- The branch direction is correlated with the branch history leading up to that branch; that is, not just the last target, but how it got to this branch.
- The source/target pair is common enough to warrant using the extra branch prediction capacity. This may increase the number of overall branch mispredictions, while improving the misprediction of indirect branches. The profitability is lower if the number of mispredicting branches is very large.

User/Source Coding Rule 1. (M impact, L generality) *If an indirect branch has two or more common taken targets and at least one of those targets is correlated with branch history leading up to the branch, then convert the indirect branch to a tree where one or more indirect branches are preceded by conditional branches to those targets. Apply this "peeling" procedure to the common target of an indirect branch that correlates to branch history.*

The purpose of this rule is to reduce the total number of mispredictions by enhancing the predictability of branches (even at the expense of adding more branches). The added branches must be predictable for this to be worthwhile. One reason for such predictability is a strong correlation with preceding branch history. That is, the directions taken on preceding branches are a good indicator of the direction of the branch under consideration.

Example 3-7 shows a simple example of the correlation between a target of a preceding conditional branch and a target of an indirect branch.

Example 3-7. Indirect Branch With Two Favored Targets

```
function ()
{
int n = rand();          // random integer 0 to RAND_MAX
  if (!(n & 0x01)) { // n will be 0 half the times
    n = 0;           // updates branch history to predict taken
  }
  // indirect branches with multiple taken targets
  // may have lower prediction rates

switch (n) {
  case 0: handle_0(); break; // common target, correlated with
                             // branch history that is forward taken
  case 1: handle_1(); break; // uncommon
  case 3: handle_3(); break; // uncommon
  default: handle_other(); // common target
}
}
```

Correlation can be difficult to determine analytically, for a compiler and for an assembly language programmer. It may be fruitful to evaluate performance with and without peeling to get the best performance from a coding effort.

An example of peeling out the most favored target of an indirect branch with correlated branch history is shown in Example 3-8.

Example 3-8. A Peeling Technique to Reduce Indirect Branch Misprediction

```

function ()
{
  int n = rand();           // Random integer 0 to RAND_MAX
  if (!(n & 0x01)) THEN
    n = 0;                 // n will be 0 half the times
  if (!n) THEN
    handle_0();           // Peel out the most common target
                        // with correlated branch history

  {
    switch (n) {
      case 1: handle_1(); break; // Uncommon
      case 3: handle_3(); break; // Uncommon

      default: handle_other(); // Make the favored target in
                              // the fall-through path
    }
  }
}

```

3.4.1.6 Loop Unrolling

Benefits of unrolling loops are:

- Unrolling amortizes the branch overhead, since it eliminates branches and some of the code to manage induction variables.
- Unrolling allows one to aggressively schedule (or pipeline) the loop to hide latencies. This is useful if you have enough free registers to keep variables live as you stretch out the dependence chain to expose the critical path.
- Unrolling exposes the code to various other optimizations, such as removal of redundant loads, common subexpression elimination, and so on.

The potential costs of unrolling loops are:

- Unrolling loops whose bodies contain branches increases demand on BTB capacity. If the number of iterations of the unrolled loop is 16 or fewer, the branch predictor should be able to correctly predict branches in the loop body that alternate direction.

Assembly/Compiler Coding Rule 14. (H impact, M generality) Unroll small loops until the overhead of the branch and induction variable accounts (generally) for less than 10% of the execution time of the loop.

Assembly/Compiler Coding Rule 15. (M impact, M generality) Unroll loops that are frequently executed and have a predictable number of iterations to reduce the number of iterations to 16 or fewer. Do this unless it increases code size so that the working set no longer fits in the instruction cache. If the loop body contains more than one conditional branch, then unroll so that the number of iterations is $16/(\# \text{ conditional branches})$.

Example 3-9 shows how unrolling enables other optimizations.

Example 3-9. Loop Unrolling

<p>Before unrolling:</p> <pre>do i = 1, 100 if (i mod 2 == 0) then a(i) = x else a(i) = y enddo</pre> <p>After unrolling</p> <pre>do i = 1, 100, 2 a(i) = y a(i+1) = x enddo</pre>
--

In this example, the loop that executes 100 times assigns X to every even-numbered element and Y to every odd-numbered element. By unrolling the loop you can make assignments more efficiently, removing one branch in the loop body.

3.4.2 Fetch and Decode Optimization

Intel Core microarchitecture provides several mechanisms to increase front end throughput. Techniques to take advantage of some of these features are discussed below.

3.4.2.1 Optimizing for Micro-fusion

An Instruction that operates on a register and a memory operand decodes into more micro-ops than its corresponding register-register version. Replacing the equivalent work of the former instruction using the register-register version usually require a sequence of two instructions. The latter sequence is likely to result in reduced fetch bandwidth.

Assembly/Compiler Coding Rule 16. (ML impact, M generality) For improving fetch/decode throughput, Give preference to memory flavor of an instruction over the register-only flavor of the same instruction, if such instruction can benefit from micro-fusion.

The following examples are some of the types of micro-fusions that can be handled by all decoders:

- All stores to memory, including store immediate. Stores execute internally as two separate micro-ops: store-address and store-data.
- All “read-modify” (load+op) instructions between register and memory, for example:

```
ADDPS  XMM9, QWORD PTR [RSP+40]
FADD   DOUBLE PTR [RDI+RSI*8]
XOR    RAX, QWORD PTR [RBP+32]
```
- All instructions of the form “load and jump,” for example:

```
JMP    [RDI+200]
RET
```
- CMP and TEST with immediate operand and memory.

An Intel 64 instruction with RIP relative addressing is not micro-fused in the following cases:

- When an additional immediate is needed, for example:

```
CMP    [RIP+400], 27
MOV    [RIP+3000], 142
```
- When an RIP is needed for control flow purposes, for example:

```
JMP    [RIP+5000000]
```

In these cases, Intel Core microarchitecture and Sandy Bridge microarchitecture provide a 2 micro-op flow from decoder 0, resulting in a slight loss of decode bandwidth since 2 micro-op flow must be steered to decoder 0 from the decoder with which it was aligned.

RIP addressing may be common in accessing global data. Since it will not benefit from micro-fusion, compiler may consider accessing global data with other means of memory addressing.

3.4.2.2 Optimizing for Macrofusion

Macrofusion merges two instructions to a single micro-op. Intel Core microarchitecture performs this hardware optimization under limited circumstances.

The first instruction of the macro-fused pair must be a CMP or TEST instruction. This instruction can be REG-REG, REG-IMM, or a micro-fused REG-MEM comparison. The second instruction (adjacent in the instruction stream) should be a conditional branch.

Since these pairs are common ingredient in basic iterative programming sequences, macrofusion improves performance even on un-recompiled binaries. All of the decoders can decode one macro-fused pair per cycle, with up to three other instructions, resulting in a peak decode bandwidth of 5 instructions per cycle.

Each macro-fused instruction executes with a single dispatch. This process reduces latency, which in this case shows up as a cycle removed from branch mispredict penalty. Software also gain all other fusion benefits: increased rename and retire bandwidth, more storage for instructions in-flight, and power savings from representing more work in fewer bits.

The following list details when you can use macrofusion:

- CMP or TEST can be fused when comparing:
 - REG-REG. For example: `CMP EAX,ECX; JZ label`
 - REG-IMM. For example: `CMP EAX,0x80; JZ label`
 - REG-MEM. For example: `CMP EAX,[ECX]; JZ label`
 - MEM-REG. For example: `CMP [EAX],ECX; JZ label`
- TEST can fused with all conditional jumps.
- CMP can be fused with only the following conditional jumps in Intel Core microarchitecture. These conditional jumps check carry flag (CF) or zero flag (ZF). jump. The list of macrofusion-capable conditional jumps are:

```
JA or JNBE
JAE or JNB or JNC
JE or JZ
JNA or JBE
JNAE or JC or JB
JNE or JNZ
```

CMP and TEST can not be fused when comparing MEM-IMM (e.g. `CMP [EAX],0x80; JZ label`). Macrofusion is not supported in 64-bit mode for Intel Core microarchitecture.

- Nehalem microarchitecture supports the following enhancements in macrofusion:
 - CMP can be fused with the following conditional jumps (that was not supported in Intel Core microarchitecture):
 - JL or JNGE
 - JGE or JNL

- JLE or JNG
- JG or JNLE
- Macrofusion is supported in 64-bit mode.
- Enhanced macrofusion support in Sandy Bridge microarchitecture is summarized in Table 3-1 with additional information in Section E.2.2.1 and Example 3-14:

Table 3-1. Macro-Fusible Instructions in Sandy Bridge Microarchitecture

Instructions	TEST	AND	CMP	ADD	SUB	INC	DEC
JO/JNO	Y	Y	N	N	N	N	N
JC/JB/JAE/JNB	Y	Y	Y	Y	Y	N	N
JE/JZ/JNE/JNZ	Y	Y	Y	Y	Y	Y	Y
JNA/JBE/JA/JNBE	Y	Y	Y	Y	Y	N	N
JS/JNS/JP/JPE/JNP/JPO	Y	Y	N	N	N	N	N
JL/JNGE/JGE/JNL/JLE/JNG/JG/JNLE	Y	Y	Y	Y	Y	Y	Y

- Enhanced macrofusion support in Haswell microarchitecture is summarized in Table 3-2. Macrofusion is supported CMP/TEST/OP with reg-imm, reg-mem, and reg-reg addressing but not mem-imm addressing.

Table 3-2. Macro-Fusible Instructions in Haswell Microarchitecture

Opcode		JCC	ADD / SUB / CMP	INC / DEC	TEST / AND
70	OF 80	Jo	N	N	Y
71	OF 81	Jno	N	N	Y
72	OF 82	Jc / Jb	Y	N	Y
73	OF 83	Jae / Jnb	Y	N	Y
74	OF 84	Je / Jz	Y	Y	Y
75	OF 85	Jne / Jnz	Y	Y	Y
76	OF 86	Jna / Jbe	Y	N	Y
77	OF 87	Ja / Jnbe	Y	N	Y
78	OF 88	Js	N	N	Y
79	OF 89	Jns	N	N	Y
7A	OF 8A	Jp / Jpe	N	N	Y
7B	OF 8B	Jnp / Jpo	N	N	Y
7C	OF 8C	Jl / Jnge	Y	Y	Y
7D	OF 8D	Jge / Jnl	Y	Y	Y
7E	OF 8E	Jle / Jng	Y	Y	Y
7F	OF 8F	Jg / Jnle	Y	Y	Y

Assembly/Compiler Coding Rule 17. (M impact, ML generality) Employ macrofusion where possible using instruction pairs that support macrofusion. Prefer TEST over CMP if possible. Use unsigned variables and unsigned jumps when possible. Try to logically verify that a variable is non-negative at the time of comparison. Avoid CMP or TEST of MEM-IMM flavor when possible. However, do not add other instructions to avoid using the MEM-IMM flavor.

Example 3-10. Macrofusion, Unsigned Iteration Count

	Without Macrofusion	With Macrofusion
C code	for (int ¹ i = 0; i < 1000; i++) a++;	for (unsigned int ² i = 0; i < 1000; i++) a++;
Disassembly	for (int i = 0; i < 1000; i++) mov dword ptr [i], 0 jmp First Loop: mov eax, dword ptr [i] add eax, 1 mov dword ptr [i], eax First: cmp dword ptr [i], 3E8H ³ jge End a++; mov eax, dword ptr [a] addq eax, 1 mov dword ptr [a], eax jmp Loop End:	for (unsigned int i = 0; i < 1000; i++) xor eax, eax mov dword ptr [i], eax jmp First Loop: mov eax, dword ptr [i] add eax, 1 mov dword ptr [i], eax First: cmp eax, 3E8H ⁴ jae End a++; mov eax, dword ptr [a] add eax, 1 mov dword ptr [a], eax jmp Loop End:

NOTES:

1. Signed iteration count inhibits macrofusion.
2. Unsigned iteration count is compatible with macrofusion.
3. CMP MEM-IMM, JGE inhibit macrofusion.
4. CMP REG-IMM, JAE permits macrofusion.

Example 3-11. Macrofusion, If Statement

	Without Macrofusion	With Macrofusion
C code	int ¹ a = 7; if (a < 77) a++; else a--;	unsigned int ² a = 7; if (a < 77) a++; else a--;
Disassembly	int a = 7; mov dword ptr [a], 7 if (a < 77) cmp dword ptr [a], 4DH ³ jge Dec	unsigned int a = 7; mov dword ptr [a], 7 if (a < 77) mov eax, dword ptr [a] cmp eax, 4DH jae Dec

Example 3-11. Macrofusion, If Statement (Contd.)

	Without Macrofusion	With Macrofusion
	<pre> a++; mov eax, dword ptr [a] add eax, 1 mov dword ptr [a], eax else jmp End a--; Dec: mov eax, dword ptr [a] sub eax, 1 mov dword ptr [a], eax End:: </pre>	<pre> a++; add eax, 1 mov dword ptr [a], eax else jmp End a--; Dec: sub eax, 1 mov dword ptr [a], eax End:: </pre>

NOTES:

1. Signed iteration count inhibits macrofusion.
2. Unsigned iteration count is compatible with macrofusion.
3. CMP MEM-IMM, JGE inhibit macrofusion.

Assembly/Compiler Coding Rule 18. (M impact, ML generality) Software can enable macro fusion when it can be logically determined that a variable is non-negative at the time of comparison; use TEST appropriately to enable macrofusion when comparing a variable with 0.

Example 3-12. Macrofusion, Signed Variable

Without Macrofusion	With Macrofusion
<pre> test ecx, ecx jle OutSideTheIF cmp ecx, 64H jge OutSideTheIF <IF BLOCK CODE> OutSideTheIF: </pre>	<pre> test ecx, ecx jle OutSideTheIF cmp ecx, 64H jae OutSideTheIF <IF BLOCK CODE> OutSideTheIF: </pre>

For either signed or unsigned variable 'a'; "CMP a,0" and "TEST a,a" produce the same result as far as the flags are concerned. Since TEST can be macro-fused more often, software can use "TEST a,a" to replace "CMP a,0" for the purpose of enabling macrofusion.

Example 3-13. Macrofusion, Signed Comparison

C Code	Without Macrofusion	With Macrofusion
if (a == 0)	<pre> cmp a, 0 jne lbl ... lbl: </pre>	<pre> test a, a jne lbl ... lbl: </pre>
if (a >= 0)	<pre> cmp a, 0 jl lbl; ... lbl: </pre>	<pre> test a, a jl lbl ... lbl: </pre>

Sandy Bridge microarchitecture enables more arithmetic and logic instructions to macro-fuse with conditional branches. In loops where the ALU ports are already congested, performing one of these macrofusions can relieve the pressure, as the macro-fused instruction consumes only port 5, instead of an ALU port plus port 5.

In Example 3-14, the "add/cmp/jnz" loop contains two ALU instructions that can be dispatched via either port 0, 1, 5. So there is higher probability of port 5 might bind to either ALU instruction causing JNZ to

wait a cycle. The “sub/jnz” loop, the likelihood of ADD/SUB/JNZ can be dispatched in the same cycle is increased because only SUB is free to bind with either port 0, 1, 5.

Example 3-14. Additional Macrofusion Benefit in Sandy Bridge Microarchitecture

Add + cmp + jnz alternative	Loop control with sub + jnz
lea rdx, buff	lea rdx, buff - 4
xor rcx, rcx	xor rcx, LEN
xor eax, eax	xor eax, eax
loop:	loop:
add eax, [rdx + 4 * rcx]	add eax, [rdx + 4 * rcx]
add rcx, 1	sub rcx, 1
cmp rcx, LEN	jnz loop
jnz loop	

3.4.2.3 Length-Changing Prefixes (LCP)

The length of an instruction can be up to 15 bytes in length. Some prefixes can dynamically change the length of an instruction that the decoder must recognize. Typically, the pre-decode unit will estimate the length of an instruction in the byte stream assuming the absence of LCP. When the predecoder encounters an LCP in the fetch line, it must use a slower length decoding algorithm. With the slower length decoding algorithm, the predecoder decodes the fetch in 6 cycles, instead of the usual 1 cycle. Normal queuing throughout of the machine pipeline generally cannot hide LCP penalties.

The prefixes that can dynamically change the length of a instruction include:

- Operand size prefix (0x66).
- Address size prefix (0x67).

The instruction MOV DX, 01234h is subject to LCP stalls in processors based on Intel Core microarchitecture, and in Intel Core Duo and Intel Core Solo processors. Instructions that contain imm16 as part of their fixed encoding but do not require LCP to change the immediate size are not subject to LCP stalls. The REX prefix (4xh) in 64-bit mode can change the size of two classes of instruction, but does not cause an LCP penalty.

If the LCP stall happens in a tight loop, it can cause significant performance degradation. When decoding is not a bottleneck, as in floating-point heavy code, isolated LCP stalls usually do not cause performance degradation.

Assembly/Compiler Coding Rule 19. (MH impact, MH generality) Favor generating code using imm8 or imm32 values instead of imm16 values.

If imm16 is needed, load equivalent imm32 into a register and use the word value in the register instead.

Double LCP Stalls

Instructions that are subject to LCP stalls and cross a 16-byte fetch line boundary can cause the LCP stall to trigger twice. The following alignment situations can cause LCP stalls to trigger twice:

- An instruction is encoded with a MODR/M and SIB byte, and the fetch line boundary crossing is between the MODR/M and the SIB bytes.
- An instruction starts at offset 13 of a fetch line references a memory location using register and immediate byte offset addressing mode.

The first stall is for the 1st fetch line, and the 2nd stall is for the 2nd fetch line. A double LCP stall causes a decode penalty of 11 cycles.

The following examples cause LCP stall once, regardless of their fetch-line location of the first byte of the instruction:

```
ADD DX, 01234H
ADD word ptr [EDX], 01234H
ADD word ptr 012345678H[EDX], 01234H
ADD word ptr [012345678H], 01234H
```

The following instructions cause a double LCP stall when starting at offset 13 of a fetch line:

```
ADD word ptr [EDX+ESI], 01234H
ADD word ptr 012H[EDX], 01234H
ADD word ptr 012345678H[EDX+ESI], 01234H
```

To avoid double LCP stalls, do not use instructions subject to LCP stalls that use SIB byte encoding or addressing mode with byte displacement.

False LCP Stalls

False LCP stalls have the same characteristics as LCP stalls, but occur on instructions that do not have any imm16 value.

False LCP stalls occur when (a) instructions with LCP that are encoded using the F7 opcodes, and (b) are located at offset 14 of a fetch line. These instructions are: not, neg, div, idiv, mul, and imul. False LCP experiences delay because the instruction length decoder can not determine the length of the instruction before the next fetch line, which holds the exact opcode of the instruction in its MODR/M byte.

The following techniques can help avoid false LCP stalls:

- Upcast all short operations from the F7 group of instructions to long, using the full 32 bit version.
- Ensure that the F7 opcode never starts at offset 14 of a fetch line.

Assembly/Compiler Coding Rule 20. (M impact, ML generality) *Ensure instructions using 0xF7 opcode byte does not start at offset 14 of a fetch line; and avoid using these instruction to operate on 16-bit data, upcast short data to 32 bits.*

Example 3-15. Avoiding False LCP Delays with 0xF7 Group Instructions

A Sequence Causing Delay in the Decoder	Alternate Sequence to Avoid Delay
neg word ptr a	movsx eax, word ptr a neg eax mov word ptr a, AX

3.4.2.4 Optimizing the Loop Stream Detector (LSD)

The LSD detects loops that have many iterations and fit into the μ op-queue. The μ op-queue streams the loop until a branch miss-prediction inevitably ends it.

LSD improves fetch bandwidth. In single thread mode, it saves power by allowing the front-end to sleep. In multi-thread mode, front-resource can better serve the other thread.

Loops qualify for LSD replay if all the following conditions are met:

- Loop body size up to 60 μ ops, with up to 15 taken branches, and up to 15 64-byte fetch lines.
- No CALL or RET.
- No mismatched stack operations (e.g., more PUSH than POP).
- More than \sim 20 iterations.

Many calculation-intensive loops, searches, and software string moves match these characteristics. These loops exceed the BPU prediction capacity and always terminate in a branch misprediction.

Assembly/Compiler Coding Rule 21. (MH impact, MH generality) Break up a loop body with a long sequence of instructions into loops of shorter instruction blocks of no more than the size of the LSD.

Allocation bandwidth in Ice Lake Client microarchitecture increased from 4 μ ops per cycle to 5 μ ops per cycle.

Assume a loop that qualifies for LSD has 23 μ ops in the loop body. The hardware unrolls the loop such that it still fits into the μ op-queue, in this case twice. The loop in the μ op-queue thus takes 46 μ ops.

The loop is sent to allocation 5 μ ops per cycle. After 45 out of the 46 μ ops are sent, in the next cycle only a single μ op is sent, which means that in that cycle, 4 of the allocation slots are wasted. This pattern repeats itself, until the loop is exited by a misprediction. Hardware loop unrolling minimizes the number of wasted slots during LSD.

3.4.2.5 Optimization for Decoded ICache

The decoded ICache is a new feature in Sandy Bridge microarchitecture. Running the code from the Decoded ICache has two advantages:

- Higher bandwidth of micro-ops feeding the out-of-order engine.
- The front end does not need to decode the code that is in the Decoded ICache; this saves power.

There is overhead in switching between the Decoded ICache and the legacy decode pipeline. If your code switches frequently between the front end and the Decoded ICache, the penalty may be higher than running only from the legacy pipeline.

To ensure “hot” code is feeding from the decoded ICache:

- Make sure each hot code block is less than about 750 instructions. Specifically, do not unroll to more than 750 instructions in a loop. This should enable Decoded ICache residency even when hyper-threading is enabled.
- For applications with very large blocks of calculations inside a loop, consider loop-fission: split the loop into multiple loops that fit in the Decoded ICache, rather than a single loop that overflows.
- If an application can be sure to run with only one thread per core, it can increase hot code block size to about 1500 instructions.

Dense Read-Modify-Write Code

The Decoded ICache can hold only up to 18 micro-ops per each 32 byte aligned memory chunk. Therefore, code with a high concentration of instructions that are encoded in a small number of bytes, yet have many micro-ops, may overflow the 18 micro-op limitation and not enter the Decoded ICache. Read-modify-write (RMW) instructions are a good example of such instructions.

RMW instructions accept one memory source operand, one register source operand, and use the source memory operand as the destination. The same functionality can be achieved by two or three instructions: the first reads the memory source operand, the second performs the operation with the second register source operand, and the last writes the result back to memory. These instructions usually result in the same number of micro-ops but use more bytes to encode the same functionality.

One case where RMW instructions may be used extensively is when the compiler optimizes aggressively for code size.

Here are some possible solutions to fit the hot code in the Decoded ICache:

- Replace RMW instructions with two or three instructions that have the same functionality. For example, “`adc [rdi], rcx`” is only three bytes long; the equivalent sequence “`adc rax, [rdi]`” + “`mov [rdi], rax`” has a footprint of six bytes.
- Align the code so that the dense part is broken down among two different 32-byte chunks. This solution is useful when using a tool that aligns code automatically, and is indifferent to code changes.
- Spread the code by adding multiple byte NOPs in the loop. Note that this solution adds micro-ops for execution.

Align Unconditional Branches for Decoded ICache

For code entering the Decoded ICache, each unconditional branch is the last micro-op occupying a Decoded ICache Way. Therefore, only three unconditional branches per a 32 byte aligned chunk can enter the Decoded ICache.

Unconditional branches are frequent in jump tables and switch declarations. Below are examples for these constructs, and methods for writing them so that they fit in the Decoded ICache.

Compilers create jump tables for C++ virtual class methods or DLL dispatch tables. Each unconditional branch consumes five bytes; therefore up to seven of them can be associated with a 32-byte chunk. Thus jump tables may not fit in the Decoded ICache if the unconditional branches are too dense in each 32Byte-aligned chunk. This can cause performance degradation for code executing before and after the branch table.

The solution is to add multi-byte NOP instructions among the branches in the branch table. This may increase code size and should be used cautiously. However, these NOPs are not executed and therefore have no penalty in later pipe stages.

Switch-Case constructs represents a similar situation. Each evaluation of a case condition results in an unconditional branch. The same solution of using multi-byte NOP can apply for every three consecutive unconditional branches that fits inside an aligned 32-byte chunk.

Two Branches in a Decoded ICache Way

The Decoded ICache can hold up to two branches in a way. Dense branches in a 32 byte aligned chunk, or their ordering with other instructions may prohibit all the micro-ops of the instructions in the chunk from entering the Decoded ICache. This does not happen often. When it does happen, you can space the code with NOP instructions where appropriate. Make sure that these NOP instructions are not part of hot code.

Assembly/Compiler Coding Rule 22. (M impact, M generality) *Avoid putting explicit references to ESP in a sequence of stack operations (POP, PUSH, CALL, RET).*

3.4.2.6 Other Decoding Guidelines

Assembly/Compiler Coding Rule 23. (ML impact, L generality) *Use simple instructions that are less than eight bytes in length.*

Assembly/Compiler Coding Rule 24. (M impact, MH generality) *Avoid using prefixes to change the size of immediate and displacement.*

Long instructions (more than seven bytes) may limit the number of decoded instructions per cycle. Each prefix adds one byte to the length of instruction, possibly limiting the decoder's throughput. In addition, multiple prefixes can only be decoded by the first decoder. These prefixes also incur a delay when decoded. If multiple prefixes or a prefix that changes the size of an immediate or displacement cannot be avoided, schedule them behind instructions that stall the pipe for some other reason.

3.5 OPTIMIZING THE EXECUTION CORE

The superscalar, out-of-order execution core(s) in recent generations of microarchitectures contain multiple execution hardware resources that can execute multiple micro-ops in parallel. These resources generally ensure that micro-ops execute efficiently and proceed with fixed latencies. General guidelines to make use of the available parallelism are:

- Follow the rules (see Section 3.4) to maximize useful decode bandwidth and front end throughput. These rules include favoring single micro-op instructions and taking advantage of micro-fusion, Stack pointer tracker and macrofusion.
- Maximize rename bandwidth. Guidelines are discussed in this section and include properly dealing with partial registers, ROB read ports and instructions which causes side-effects on flags.
- Scheduling recommendations on sequences of instructions so that multiple dependency chains are alive in the reservation station (RS) simultaneously, thus ensuring that your code utilizes maximum parallelism.

- Avoid hazards, minimize delays that may occur in the execution core, allowing the dispatched micro-ops to make progress and be ready for retirement quickly.

3.5.1 Instruction Selection

Some execution units are not pipelined, this means that micro-ops cannot be dispatched in consecutive cycles and the throughput is less than one per cycle.

It is generally a good starting point to select instructions by considering the number of micro-ops associated with each instruction, favoring in the order of: single micro-op instructions, simple instruction with less than 4 micro-ops, and last instruction requiring microsequencer ROM (micro-ops which are executed out of the microsequencer involve extra overhead).

Assembly/Compiler Coding Rule 25. (M impact, H generality) *Favor single-micro-operation instructions. Also favor instruction with shorter latencies.*

A compiler may be already doing a good job on instruction selection. If so, user intervention usually is not necessary.

Assembly/Compiler Coding Rule 26. (M impact, L generality) *Avoid prefixes, especially multiple non-OF-prefixed opcodes.*

Assembly/Compiler Coding Rule 27. (M impact, L generality) *Do not use many segment registers.*

Assembly/Compiler Coding Rule 28. (M impact, M generality) *Avoid using complex instructions (for example, enter, leave, or loop) that have more than four μ ops and require multiple cycles to decode. Use sequences of simple instructions instead.*

Assembly/Compiler Coding Rule 29. (MH impact, M generality) *Use push/pop to manage stack space and address adjustments between function calls/returns instead of enter/leave. Using enter instruction with non-zero immediates can experience significant delays in the pipeline in addition to misprediction.*

Theoretically, arranging instructions sequence to match the 4-1-1-1 template applies to processors based on Intel Core microarchitecture. However, with macrofusion and micro-fusion capabilities in the front end, attempts to schedule instruction sequences using the 4-1-1-1 template will likely provide diminishing returns.

Instead, software should follow these additional decoder guidelines:

- If you need to use multiple micro-op, non-microsequenced instructions, try to separate by a few single micro-op instructions. The following instructions are examples of multiple micro-op instruction not requiring micro-sequencer:

```
ADC/SBB
CMOVcc
Read-modify-write instructions
```

- If a series of multiple micro-op instructions cannot be separated, try breaking the series into a different equivalent instruction sequence. For example, a series of read-modify-write instructions may go faster if sequenced as a series of read-modify + store instructions. This strategy could improve performance even if the new code sequence is larger than the original one.

3.5.1.1 Integer Divide

Typically, an integer divide is preceded by a CWD or CDQ instruction. Depending on the operand size, divide instructions use DX:AX or EDX:EAX for the dividend. The CWD or CDQ instructions sign-extend AX or EAX into DX or EDX, respectively. These instructions have denser encoding than a shift and move would be, but they generate the same number of micro-ops. If AX or EAX is known to be positive, replace these instructions with:

```
xor dx, dx
```

or

```
xor edx, edx
```

Modern compilers typically can transform high-level language expression involving integer division where the divisor is a known integer constant at compile time into a faster sequence using IMUL instruction instead. Thus programmers should minimize integer division expression with divisor whose value can not be known at compile time.

Alternately, if certain known divisor value are favored over other unknown ranges, software may consider isolating the few favored, known divisor value into constant-divisor expressions.

Section 13.2.4 describes more detail of using MUL/IMUL to replace integer divisions.

3.5.1.2 Using LEA

In Sandy Bridge microarchitecture, there are two significant changes to the performance characteristics of LEA instruction:

- LEA can be dispatched via port 1 and 5 in most cases, doubling the throughput over prior generations. However this apply only to LEA instructions with one or two source operands.

Example 3-16. Independent Two-Operand LEA Example

```

mov    edx, N
mov    eax, X
mov    ecx, Y

loop:
lea    ecx, [ecx + ecx]    // ecx = ecx*2
lea    eax, [eax + eax *4] // eax = eax*5
and    ecx, 0xff
and    eax, 0xff
dec    edx
jg     loop

```

- For LEA instructions with three source operands and some specific situations, instruction latency has increased to 3 cycles, and must dispatch via port 1:
 - LEA that has all three source operands: base, index, and offset.
 - LEA that uses base and index registers where the base is EBP, RBP, or R13.
 - LEA that uses RIP relative addressing mode.
 - LEA that uses 16-bit addressing mode.

Example 3-17. Alternative to Three-Operand LEA

3 operand LEA is slower	Two-operand LEA alternative	Alternative 2
<pre>#define K 1 uint32 an = 0; uint32 N= mi_N; mov ecx, N xor esi, esi; xor edx, edx; cmp ecx, 2; jb finished; dec ecx; loop1: mov edi, esi; lea esi, [K+esi+edx]; and esi, 0xFF; mov edx, edi; dec ecx; jnz loop1; finished: mov [an],esi;</pre>	<pre>#define K 1 uint32 an = 0; uint32 N= mi_N; mov ecx, N xor esi, esi; xor edx, edx; cmp ecx, 2; jb finished; dec ecx; loop1: mov edi, esi; lea esi, [K+edx]; lea esi, [esi+edx]; and esi, 0xFF; mov edx, edi; dec ecx; jnz loop1; finished: mov [an],esi;</pre>	<pre>#define K 1 uint32 an = 0; uint32 N= mi_N; mov ecx, N xor esi, esi; mov edx, K; cmp ecx, 2; jb finished; mov eax, 2 dec ecx; loop1: mov edi, esi; lea esi, [esi+edx]; and esi, 0xFF; lea edx, [edi +K]; dec ecx; jnz loop1; finished: mov [an],esi;</pre>

The LEA instruction or a sequence of LEA, ADD, SUB and SHIFT instructions can replace constant multiply instructions. The LEA instruction can also be used as a multiple operand addition instruction, for example:

```
LEA ECX, [EAX + EBX*4 + A]
```

Using LEA in this way may avoid register usage by not tying up registers for operands of arithmetic instructions. This use may also save code space.

If the LEA instruction uses a shift by a constant amount then the latency of the sequence of μ ops is shorter if adds are used instead of a shift, and the LEA instruction may be replaced with an appropriate sequence of μ ops. This, however, increases the total number of μ ops, leading to a trade-off.

Assembly/Compiler Coding Rule 30. (ML impact, L generality) *If an LEA instruction using the scaled index is on the critical path, a sequence with ADDs may be better.*

3.5.1.3 ADC and SBB in Sandy Bridge Microarchitecture

The throughput of ADC and SBB in Sandy Bridge microarchitecture is 1 cycle, compared to 1.5-2 cycles in the prior generation. These two instructions are useful in numeric handling of integer data types that are wider than the maximum width of native hardware.

Example 3-18. Examples of 512-bit Additions

<pre>//Add 64-bit to 512 Number lea rsi, gLongCounter lea rdi, gStepValue mov rax, [rdi] xor rcx, rcx oop_start: mov r10, [rsi+rcx] add r10, rax mov [rsi+rcx], r10 mov r10, [rsi+rcx+8] adc r10, 0 mov [rsi+rcx+8], r10 mov r10, [rsi+rcx+16] adc r10, 0 mov [rsi+rcx+16], r10 mov r10, [rsi+rcx+24] adc r10, 0 mov [rsi+rcx+24], r10 mov r10, [rsi+rcx+32] adc r10, 0 mov [rsi+rcx+32], r10 mov r10, [rsi+rcx+40] adc r10, 0 mov [rsi+rcx+40], r10 mov r10, [rsi+rcx+48] adc r10, 0 mov [rsi+rcx+48], r10 mov r10, [rsi+rcx+56] adc r10, 0 mov [rsi+rcx+56], r10 add rcx, 64 cmp rcx, SIZE jnz loop_start</pre>	<pre>// 512-bit Addition loop1: mov rax, [StepValue] add rax, [LongCounter] mov LongCounter, rax mov rax, [StepValue+8] adc rax, [LongCounter+8] mov LongCounter+8, rax mov rax, [StepValue+16] adc rax, [LongCounter+16] mov LongCounter+16, rax mov rax, [StepValue+24] adc rax, [LongCounter+24] mov LongCounter+24, rax mov rax, [StepValue+32] adc rax, [LongCounter+32] mov LongCounter+32, rax mov rax, [StepValue+40] adc rax, [LongCounter+40] mov LongCounter+40, rax mov rax, [StepValue+48] adc rax, [LongCounter+48] mov LongCounter+48, rax mov rax, [StepValue+56] adc rax, [LongCounter+56] mov LongCounter+56, rax dec rcx jnz loop1</pre>
--	---

3.5.1.4 Bitwise Rotation

Bitwise rotation can choose between rotate with count specified in the CL register, an immediate constant and by 1 bit. Generally, The rotate by immediate and rotate by register instructions are slower than rotate by 1 bit. The rotate by 1 instruction has the same latency as a shift.

Assembly/Compiler Coding Rule 31. (ML impact, L generality) Avoid ROTATE by register or ROTATE by immediate instructions. If possible, replace with a ROTATE by 1 instruction.

In Sandy Bridge microarchitecture, ROL/ROR by immediate has 1-cycle throughput, SHLD/SHRD using the same register as source and destination by an immediate constant has 1-cycle latency with 0.5 cycle throughput. The “ROL/ROR reg, imm8” instruction has two micro-ops with the latency of 1-cycle for the rotate register result and 2-cycles for the flags, if used.

In Ivy Bridge microarchitecture, The “ROL/ROR reg, imm8” instruction with immediate greater than 1, is one micro-op with one-cycle latency when the overflow flag result is used. When the immediate is one, dependency on the overflow flag result of ROL/ROR by a subsequent instruction will see the ROL/ROR instruction with two-cycle latency.

3.5.1.5 Variable Bit Count Rotation and Shift

In Sandy Bridge microarchitecture, The “ROL/ROR/SHL/SHR reg, cl” instruction has three micro-ops. When the flag result is not needed, one of these micro-ops may be discarded, providing better performance in many common usages. When these instructions update partial flag results that are subsequently used, the full three micro-ops flow must go through the execution and retirement pipeline, experiencing slower performance. In Ivy Bridge microarchitecture, executing the full three micro-ops flow to use the updated partial flag result has additional delay. Consider the looped sequence below:

loop:

```
shl eax, cl
add ebx, eax
dec edx ; DEC does not update carry, causing SHL to execute slower three micro-ops flow
jnz loop
```

The DEC instruction does not modify the carry flag. Consequently, the SHL EAX, CL instruction needs to execute the three micro-ops flow in subsequent iterations. The SUB instruction will update all flags. So replacing DEC with SUB will allow SHL EAX, CL to execute the two micro-ops flow.

3.5.1.6 Address Calculations

For computing addresses, use the addressing modes rather than general-purpose computations. Internally, memory reference instructions can have four operands:

- Relocatable load-time constant.
- Immediate constant.
- Base register.
- Scaled index register.

Note that the latency and throughput of LEA with more than two operands are slower (see Section 3.5.1.2) in Sandy Bridge microarchitecture. Addressing modes that uses both base and index registers will consume more read port resource in the execution engine and may experience more stalls due to availability of read port resources. Software should take care by selecting the speedy version of address calculation.

In the segmented model, a segment register may constitute an additional operand in the linear address calculation. In many cases, several integer instructions can be eliminated by fully using the operands of memory references.

3.5.1.7 Clearing Registers and Dependency Breaking Idioms

Code sequences that modifies partial register can experience some delay in its dependency chain, but can be avoided by using dependency breaking idioms.

In processors based on Intel Core microarchitecture, a number of instructions can help clear execution dependency when software uses these instruction to clear register content to zero. The instructions include:

```
XOR REG, REG
SUB REG, REG
XORPS/PD XMMREG, XMMREG
PXOR XMMREG, XMMREG
SUBPS/PD XMMREG, XMMREG
PSUBB/W/D/Q XMMREG, XMMREG
```

In processors based on Sandy Bridge microarchitecture, the instruction listed above plus equivalent AVX counter parts are also zero idioms that can be used to break dependency chains. Furthermore, they do not consume an issue port or an execution unit. So using zero idioms are preferable than moving 0's into the register. The AVX equivalent zero idioms are:

```
VXORPS/PD XMMREG, XMMREG
VXORPS/PD YMMREG, YMMREG
VPXOR XMMREG, XMMREG
VSUBPS/PD XMMREG, XMMREG
VSUBPS/PD YMMREG, YMMREG
VPSUBB/W/D/Q XMMREG, XMMREG
```

Microarchitectures that support Intel AVX-512 have the equivalent of zero idioms for the 512-bit registers using the unmasked versions of the instructions:

```
VXORPS/PD ZMMREG, ZMMREG
VPXOR ZMMREG, ZMMREG
VSUBPS/PD ZMMREG, ZMMREG
VPSUBB/W/D/Q ZMMREG, ZMMREG
```

The XOR and SUB instructions can be used to clear execution dependencies on the zero evaluation of the destination register.

Assembly/Compiler Coding Rule 32. (M impact, ML generality) Use dependency-breaking-idiom instructions to set a register to 0, or to break a false dependence chain resulting from re-use of registers. In contexts where the condition codes must be preserved, move 0 into the register instead. This requires more code space than using XOR and SUB, but avoids setting the condition codes.

Example 3-19 of using pxor to break dependency idiom on a XMM register when performing negation on the elements of an array.

```
int a[4096], b[4096], c[4096];
For ( int i = 0; i < 4096; i++ )
    C[i] = - ( a[i] + b[i] );
```

Example 3-19. Clearing Register to Break Dependency While Negating Array Elements

Negation (-x = (x XOR (-1)) - (-1) without breaking dependency	Negation (-x = 0 -x) using PXOR reg, reg breaks dependency
<pre> Lea eax, a lea ecx, b lea edi, c xor edx, edx movdqa xmm7, allone lp: movdqa xmm0, [eax + edx] padd xmm0, [ecx + edx] pxor xmm0, xmm7 psubd xmm0, xmm7 movdqa [edi + edx], xmm0 add edx, 16 cmp edx, 4096 jl lp </pre>	<pre> lea eax, a lea ecx, b lea edi, c xor edx, edx lp: movdqa xmm0, [eax + edx] padd xmm0, [ecx + edx] pxor xmm7, xmm7 psubd xmm7, xmm0 movdqa [edi + edx], xmm7 add edx, 16 cmp edx, 4096 jl lp </pre>

Assembly/Compiler Coding Rule 33. (M impact, MH generality) Break dependences on portions of registers between instructions by operating on 32-bit registers instead of partial registers. For moves, this can be accomplished with 32-bit moves or by using MOVZX.

Sometimes sign-extended semantics can be maintained by zero-extending operands. For example, the C code in the following statements does not need sign extension, nor does it need prefixes for operand size overrides:

```

static short INT a, b;
IF (a == b) {
    ...
}

```

Code for comparing these 16-bit operands might be:

```

MOVZW EAX, [a]
MOVZW EBX, [b]
CMP EAX, EBX

```

These circumstances tend to be common. However, the technique will not work if the compare is for greater than, less than, greater than or equal, and so on, or if the values in eax or ebx are to be used in another operation where sign extension is required.

Assembly/Compiler Coding Rule 34. (M impact, M generality) Try to use zero extension or operate on 32-bit operands instead of using moves with sign extension.

The trace cache can be packed more tightly when instructions with operands that can only be represented as 32 bits are not adjacent.

Assembly/Compiler Coding Rule 35. (ML impact, L generality) Avoid placing instructions that use 32-bit immediates which cannot be encoded as sign-extended 16-bit immediates near each other. Try to schedule μ ops that have no immediate immediately before or after μ ops with 32-bit immediates.

3.5.1.8 Compares

Use TEST when comparing a value in a register with zero. TEST essentially ANDs operands together without writing to a destination register. TEST is preferred over AND because AND produces an extra result register. TEST is better than CMP ..., 0 because the instruction size is smaller.

Use TEST when comparing the result of a logical AND with an immediate constant for equality or inequality if the register is EAX for cases such as:

```
IF (AVAR & 8) { }
```

The TEST instruction can also be used to detect rollover of modulo of a power of 2. For example, the C code:

```
IF ( (AVAR % 16) == 0 ) { }
```

can be implemented using:

```
TEST    EAX, 0x0F
JNZ     AfterIf
```

Using the TEST instruction between the instruction that may modify part of the flag register and the instruction that uses the flag register can also help prevent partial flag register stall.

Assembly/Compiler Coding Rule 36. (ML impact, M generality) Use the TEST instruction instead of AND when the result of the logical AND is not used. This saves μops in execution. Use a TEST of a register with itself instead of a CMP of the register to zero, this saves the need to encode the zero and saves encoding space. Avoid comparing a constant to a memory operand. It is preferable to load the memory operand and compare the constant to a register.

Often a produced value must be compared with zero, and then used in a branch. Because most Intel architecture instructions set the condition codes as part of their execution, the compare instruction may be eliminated. Thus the operation can be tested directly by a JCC instruction. The notable exceptions are MOV and LEA. In these cases, use TEST.

Assembly/Compiler Coding Rule 37. (ML impact, M generality) Eliminate unnecessary compare with zero instructions by using the appropriate conditional jump instruction when the flags are already set by a preceding arithmetic instruction. If necessary, use a TEST instruction instead of a compare. Be certain that any code transformations made do not introduce problems with overflow.

3.5.1.9 Using NOPs

Code generators generate a no-operation (NOP) to align instructions. Examples of NOPs of different lengths in 32-bit mode are shown in Table 3-3.

Table 3-3. Recommended Multi-Byte Sequence of NOP Instruction

Length	Assembly	Byte Sequence
2 bytes	66 NOP	66 90H
3 bytes	NOP DWORD ptr [EAX]	0F 1F 00H
4 bytes	NOP DWORD ptr [EAX + 00H]	0F 1F 40 00H
5 bytes	NOP DWORD ptr [EAX + EAX*1 + 00H]	0F 1F 44 00 00H
6 bytes	66 NOP DWORD ptr [EAX + EAX*1 + 00H]	66 0F 1F 44 00 00H
7 bytes	NOP DWORD ptr [EAX + 00000000H]	0F 1F 80 00 00 00 00H
8 bytes	NOP DWORD ptr [EAX + EAX*1 + 00000000H]	0F 1F 84 00 00 00 00 00H
9 bytes	66 NOP DWORD ptr [EAX + EAX*1 + 00000000H]	66 0F 1F 84 00 00 00 00 00H

These are all true NOPs, having no effect on the state of the machine except to advance the EIP. Because NOPs require hardware resources to decode and execute, use the fewest number to achieve the desired padding.

The one byte NOP:[XCHG EAX,EAX] has special hardware support. Although it still consumes a μop and its accompanying resources, the dependence upon the old value of EAX is removed. This μop can be executed at the earliest possible opportunity, reducing the number of outstanding instructions, and is the lowest cost NOP.

The other NOPs have no special hardware support. Their input and output registers are interpreted by the hardware. Therefore, a code generator should arrange to use the register containing the oldest value as input, so that the NOP will dispatch and release RS resources at the earliest possible opportunity.

Try to observe the following NOP generation priority:

- Select the smallest number of NOPs and pseudo-NOPs to provide the desired padding.
- Select NOPs that are least likely to execute on slower execution unit clusters.
- Select the register arguments of NOPs to reduce dependencies.

3.5.1.10 Mixing SIMD Data Types

Previous microarchitectures (before Intel Core microarchitecture) do not have explicit restrictions on mixing integer and floating-point (FP) operations on XMM registers. For Intel Core microarchitecture, mixing integer and floating-point operations on the content of an XMM register can degrade performance. Software should avoid mixed-use of integer/FP operation on XMM registers. Specifically:

- Use SIMD integer operations to feed SIMD integer operations. Use PXOR for idiom.
- Use SIMD floating-point operations to feed SIMD floating-point operations. Use XORPS for idiom.
- When floating-point operations are bitwise equivalent, use PS data type instead of PD data type. MOVAPS and MOVAPD do the same thing, but MOVAPS takes one less byte to encode the instruction.

3.5.1.11 Spill Scheduling

The spill scheduling algorithm used by a code generator will be impacted by the memory subsystem. A spill scheduling algorithm is an algorithm that selects what values to spill to memory when there are too many live values to fit in registers. Consider the code in Example 3-20, where it is necessary to spill either A, B, or C.

Example 3-20. Spill Scheduling Code

```
LOOP
  C := ...
  B := ...
  A := A + ...
```

For modern microarchitectures, using dependence depth information in spill scheduling is even more important than in previous processors. The loop-carried dependence in A makes it especially important that A not be spilled. Not only would a store/load be placed in the dependence chain, but there would also be a data-not-ready stall of the load, costing further cycles.

Assembly/Compiler Coding Rule 38. (H impact, MH generality) *For small loops, placing loop invariants in memory is better than spilling loop-carried dependencies.*

A possibly counter-intuitive result is that in such a situation it is better to put loop invariants in memory than in registers, since loop invariants never have a load blocked by store data that is not ready.

3.5.1.12 Zero-Latency MOV Instructions

In processors based on Ivy Bridge microarchitecture, a subset of register-to-register move operations are executed in the front end (similar to zero-idioms, see Section 3.5.1.7). This conserves scheduling/execution resources in the out-of-order engine. Most forms of register-to-register MOV instructions

can benefit from zero-latency MOV. Example 3-21 list the details of those forms that qualify and a small set that do not.

Example 3-21. Zero-Latency MOV Instructions

MOV instructions latency that can be eliminated	MOV instructions latency that cannot be eliminated
MOV reg32, reg32 MOV reg64, reg64 MOVUPD/MOVAPD xmm, xmm MOVUPD/MOVAPD ymm, ymm MOVUPS?MOVAPS xmm, xmm MOVUPS/MOVAPS ymm, ymm MOVDQA/MOVDQU xmm, xmm MOVDQA/MOVDQU ymm, ymm MOVDQA/MOVDQU zmm, zmm MOVZX reg32, reg8 (if not AH/BH/CH/DH) MOVZX reg64, reg8 (if not AH/BH/CH/DH)	MOV reg8, reg8 MOV reg16, reg16 MOVZX reg32, reg8 (if AH/BH/CH/DH) MOVZX reg64, reg8 (if AH/BH/CH/DH) MOVSX

Example 3-22 shows how to process 8-bit integers using MOVZX to take advantage of zero-latency MOV enhancement. Consider

$$X = (X * 3^N) \text{ MOD } 256;$$

$$Y = (Y * 3^N) \text{ MOD } 256;$$

When “MOD 256” is implemented using the “AND 0xff” technique, its latency is exposed in the result-dependency chain. Using a form of MOVZX on a truncated byte input, it can take advantage of zero-latency MOV enhancement and gain about 45% in speed.

Example 3-22. Byte-Granular Data Computation Technique

Use AND Reg32, 0xff	Use MOVZX
<pre> mov rsi, N mov rax, X mov rcx, Y loop: lea rcx, [rcx+rcx*2] lea rax, [rax+rax*4] and rcx, 0xff and rax, 0xff lea rcx, [rcx+rcx*2] lea rax, [rax+rax*4] and rcx, 0xff and rax, 0xff sub rsi, 2 jg loop </pre>	<pre> mov rsi, N mov rax, X mov rcx, Y loop: lea rbx, [rcx+rcx*2] movzx, rcx, bl lea rbx, [rcx+rcx*2] movzx, rcx, bl lea rdx, [rax+rax*4] movzx, rax, dl llea rdx, [rax+rax*4] movzx, rax, dl sub rsi, 2 jg loop </pre>

The effectiveness of coding a dense sequence of instructions to rely on a zero-latency MOV instruction must also consider internal resource constraints in the microarchitecture.

Example 3-23. Re-ordering Sequence to Improve Effectiveness of Zero-Latency MOV Instructions

Needing more internal resource for zero-latency MOVs	Needing less internal resource for zero-latency MOVs
<pre> mov rsi, N mov rax, X mov rcx, Y loop: lea rbx, [rcx+rcx*2] movzx, rcx, bl lea rdx, [rax+rax*4] movzx, rax, dl lea rbx, [rcx+rcx*2] movzx, rcx, bl llea rdx, [rax+rax*4] movzx, rax, dl sub rsi, 2 jg loop </pre>	<pre> mov rsi, N mov rax, X mov rcx, Y loop: lea rbx, [rcx+rcx*2] movzx, rcx, bl lea rbx, [rcx+rcx*2] movzx, rcx, bl lea rdx, [rax+rax*4] movzx, rax, dl llea rdx, [rax+rax*4] movzx, rax, dl sub rsi, 2 jg loop </pre>

In Example 3-23, RBX/RCX and RDX/RAX are pairs of registers that are shared and continuously overwritten. In the right-hand sequence, registers are overwritten with new results immediately, consuming less internal resources provided by the underlying microarchitecture. As a result, it is about 8% faster than the left-hand sequence where internal resources could only support 50% of the attempt to take advantage of zero-latency MOV instructions.

3.5.2 Avoiding Stalls in Execution Core

Although the design of the execution core is optimized to make common cases executes quickly. A micro-op may encounter various hazards, delays, or stalls while making forward progress from the front end to the ROB and RS. The significant cases are:

- ROB Read Port Stalls.
- Partial Register Reference Stalls.
- Partial Updates to XMM Register Stalls.
- Partial Flag Register Reference Stalls.

3.5.2.1 Writeback Bus Conflicts

The writeback bus inside the execution engine is a common resource needed to facilitate out-of-order execution of micro-ops in flight. When the writeback bus is needed at the same time by two micro-ops executing in the same stack of execution units (see Table E-11 in Appendix E, “Earlier Generations of Intel® 64 and IA-32 Processor Architectures”), the younger micro-op will have to wait for the writeback bus to be available. This situation typically will be more likely for short-latency instructions experience a delay when it might have been otherwise ready for dispatching into the execution engine.

Consider a repeating sequence of independent floating-point ADDs with a single-cycle MOV bound to the same dispatch port. When the MOV finds the dispatch port available, the writeback bus can be occupied by the ADD. This delays the MOV operation.

If this problem is detected, you can sometimes change the instruction selection to use a different dispatch port and reduce the writeback contention.

3.5.2.2 Bypass between Execution Domains

Floating-point (FP) loads have an extra cycle of latency. Moves between FP and SIMD stacks have another additional cycle of latency.

Example:

```
ADDPS XMM0, XMM1
PAND XMM0, XMM3
ADDPS XMM2, XMM0
```

The overall latency for the above calculation is 9 cycles:

- 3 cycles for each ADDPS instruction.
- 1 cycle for the PAND instruction.
- 1 cycle to bypass between the ADDPS floating-point domain to the PAND integer domain.
- 1 cycle to move the data from the PAND integer to the second floating-point ADDPS domain.

To avoid this penalty, organize code to minimize domain changes. Sometimes bypasses cannot be avoided.

Account for bypass cycles when counting the overall latency of your code. If your calculation is latency-bound, you can execute more instructions in parallel or break dependency chains to reduce total latency.

Code that has many bypass domains and is completely latency-bound may run slower on the Intel Core microarchitecture than it did on previous microarchitectures.

3.5.2.3 Partial Register Stalls

General purpose registers can be accessed in granularities of bytes, words, doublewords; 64-bit mode also supports quadword granularity. Referencing a portion of a register is referred to as a partial register reference.

A partial register stall happens when an instruction refers to a register, portions of which were previously modified by other instructions. For example, partial register stalls occurs with a read to AX while previous instructions stored AL and AH, or a read to EAX while previous instruction modified AX.

The delay of a partial register stall is small in processors based on Intel Core microarchitecture, and in Pentium M processor (with CPUID signature family 6, model 13), Intel Core Solo, and Intel Core Duo processors. Pentium M processors (CPUID signature with family 6, model 9) and the P6 family incur a large penalty.

Note that in Intel 64 architecture, an update to the lower 32 bits of a 64 bit integer register is architecturally defined to zero extend the upper 32 bits. While this action may be logically viewed as a 32 bit update, it is really a 64 bit update (and therefore does not cause a partial stall).

Referencing partial registers frequently produces code sequences with either false or real dependencies. Example 3-16 demonstrates a series of false and real dependencies caused by referencing partial registers.

If instructions 4 and 6 (in Example 3-16) are changed to use a movzx instruction instead of a mov, then the dependences of instruction 4 on 2 (and transitively 1 before it), and instruction 6 on 5 are broken. This creates two independent chains of computation instead of one serial one.

Example 3-24 illustrates the use of MOVZX to avoid a partial register stall when packing three byte values into a register.

Example 3-24. Avoiding Partial Register Stalls in Integer Code

A Sequence Causing Partial Register Stall	Alternate Sequence Using MOVZX to Avoid Delay
<pre>mov al, byte ptr a[2] shl eax, 16 mov ax, word ptr a movd mm0, eax ret</pre>	<pre>movzx eax, byte ptr a[2] shl eax, 16 movzx ecx, word ptr a or eax, ecx movd mm0, eax ret</pre>

Beginning with Sandy Bridge microarchitecture and all subsequent generations of Intel Core microarchitecture, partial register access is handled in hardware by inserting a micro-op that merges the partial register with the full register in the following cases:

- After a write to one of the registers AH, BH, CH or DH and before a following read of the 2-, 4- or 8-byte form of the same register. In these cases a merge micro-op is inserted. The insertion consumes a full allocation cycle in which other micro-ops cannot be allocated.
- After a micro-op with a destination register of 1 or 2 bytes, which is not a source of the instruction (or the register's bigger form), and before a following read of a 2-, 4- or 8-byte form of the same register. In these cases the merge micro-op is part of the flow. For example:
 - `MOV AX, [BX]`
When you want to load from memory to a partial register, consider using MOVZX or MOVSX to avoid the additional merge micro-op penalty.
 - `LEA AX, [BX+CX]`

For optimal performance, use of zero idioms, before the use of the register, eliminates the need for partial register merge micro-ops.

3.5.2.4 Partial XMM Register Stalls

Partial register stalls can also apply to XMM registers. The following SSE and SSE2 instructions update only part of the destination register:

```
MOVL/HPD XMM, MEM64
MOVL/HPS XMM, MEM32
MOVSS/SD between registers
```

Using these instructions creates a dependency chain between the unmodified part of the register and the modified part of the register. This dependency chain can cause performance loss.

Example 3-25 illustrates the use of MOVZX to avoid a partial register stall when packing three byte values into a register.

Follow these recommendations to avoid stalls from partial updates to XMM registers:

- Avoid using instructions which update only part of the XMM register.
- If a 64-bit load is needed, use the MOVSD or MOVQ instruction.
- If 2 64-bit loads are required to the same register from non continuous locations, use MOVSD/MOVHPD instead of MOVLPD/MOVHPD.
- When copying the XMM register, use the following instructions for full register copy, even if you only want to copy some of the source register data:

```
MOVAPS
MOVAPD
MOVDQA
```

Example 3-25. Avoiding Partial Register Stalls in SIMD Code

Using movlpd for memory transactions and movsd between register copies Causing Partial Register Stall	Using movsd for memory and movapd between register copies Avoid Delay
<pre> mov edx, x mov ecx, count movlpd xmm3, _1_ movlpd xmm2, _1pt5_ align 16 lp: movlpd xmm0, [edx] addsd xmm0, xmm3 movsd xmm1, xmm2 subsd xmm1, [edx] mulsd xmm0, xmm1 movsd [edx], xmm0 add edx, 8 dec ecx jnz lp </pre>	<pre> mov edx, x mov ecx, count movsd xmm3, _1_ movsd xmm2, _1pt5_ align 16 lp: movsd xmm0, [edx] addsd xmm0, xmm3 movapd xmm1, xmm2 subsd xmm1, [edx] mulsd xmm0, xmm1 movsd [edx], xmm0 add edx, 8 dec ecx jnz lp </pre>

3.5.2.5 Partial Flag Register Stalls

A “partial flag register stall” occurs when an instruction modifies a part of the flag register and the following instruction is dependent on the outcome of the flags. This happens most often with shift instructions (SAR, SAL, SHR, SHL). The flags are not modified in the case of a zero shift count, but the shift count is usually known only at execution time. The front end stalls until the instruction is retired.

Other instructions that can modify some part of the flag register include CMPXCHG8B, various rotate instructions, STC, and STD. An example of assembly with a partial flag register stall and alternative code without the stall is shown in Example 3-26.

In processors based on Intel Core microarchitecture, shift immediate by 1 is handled by special hardware such that it does not experience partial flag stall.

Example 3-26. Avoiding Partial Flag Register Stalls

Partial Flag Register Stall	Avoiding Partial Flag Register Stall
<pre> xor eax, eax mov ecx, a sar ecx, 2 setz al ;SAR can update carry causing a stall </pre>	<pre> or eax, eax mov ecx, a sar ecx, 2 test ecx, ecx ; test always updates all flags setz al ;No partial reg or flag stall, </pre>

In Sandy Bridge microarchitecture, the cost of partial flag access is replaced by the insertion of a micro-op instead of a stall. However, it is still recommended to use less of instructions that write only to some of the flags (such as INC, DEC, SET CL) before instructions that can write flags conditionally (such as SHIFT CL).

Example 3-27 compares two techniques to implement the addition of very large integers (e.g., 1024 bits). The alternative sequence on the right side of Example 3-27 will be faster than the left side on Sandy Bridge microarchitecture, but it will experience partial flag stalls on prior microarchitectures.

Example 3-27. Partial Flag Register Accesses in Sandy Bridge Microarchitecture

Save partial flag register to avoid stall	Simplified code sequence
<pre> lea rsi, [A] lea rdi, [B] xor rax, rax mov rcx, 16 ; 16*64 =1024 bit lp_64bit: add rax, [rsi] adc rax, [rdi] mov [rdi], rax setc al ;save carry for next iteration movzx rax, al add rsi, 8 add rdi, 8 dec rcx jnz lp_64bit </pre>	<pre> lea rsi, [A] lea rdi, [B] xor rax, rax mov rcx, 16 lp_64bit: add rax, [rsi] adc rax, [rdi] mov [rdi], rax lea rsi, [rsi+8] lea rdi, [rdi+8] dec rcx jnz lp_64bit </pre>

3.5.2.6 Floating-Point/SIMD Operands

Moves that write a portion of a register can introduce unwanted dependences. The MOVSD REG, REG instruction writes only the bottom 64 bits of a register, not all 128 bits. This introduces a dependence on the preceding instruction that produces the upper 64 bits (even if those bits are not longer wanted). The dependence inhibits register renaming, and thereby reduces parallelism.

Use MOVAPD as an alternative; it writes all 128 bits. Even though this instruction has a longer latency, the μ ops for MOVAPD use a different execution port and this port is more likely to be free. The change can impact performance. There may be exceptional cases where the latency matters more than the dependence or the execution port.

Assembly/Compiler Coding Rule 39. (M impact, ML generality) *Avoid introducing dependences with partial floating-point register writes, e.g. from the MOVSD XMMREG1, XMMREG2 instruction. Use the MOVAPD XMMREG1, XMMREG2 instruction instead.*

The MOVSD XMMREG, MEM instruction writes all 128 bits and breaks a dependence.

3.5.3 Vectorization

This section provides a brief summary of optimization issues related to vectorization. There is more detail in the chapters that follow.

Vectorization is a program transformation that allows special hardware to perform the same operation on multiple data elements at the same time. Successive processor generations have provided vector support through the MMX technology, Streaming SIMD Extensions (SSE), Streaming SIMD Extensions 2 (SSE2), Streaming SIMD Extensions 3 (SSE3) and Supplemental Streaming SIMD Extensions 3 (SSSE3).

Vectorization is a special case of SIMD, a term defined in Flynn's architecture taxonomy to denote a single instruction stream capable of operating on multiple data elements in parallel. The number of elements which can be operated on in parallel range from four single-precision floating-point data elements in Streaming SIMD Extensions and two double-precision floating-point data elements in Streaming SIMD Extensions 2 to sixteen byte operations in a 128-bit register in Streaming SIMD Extensions 2. Thus, vector length ranges from 2 to 16, depending on the instruction extensions used and on the data type.

The Intel C++ Compiler supports vectorization in three ways:

- The compiler may be able to generate SIMD code without intervention from the user.

- The user can insert pragmas to help the compiler realize that it can vectorize the code.
- The user can write SIMD code explicitly using intrinsics and C++ classes.

To help enable the compiler to generate SIMD code, avoid global pointers and global variables. These issues may be less troublesome if all modules are compiled simultaneously, and whole-program optimization is used.

User/Source Coding Rule 2. (H impact, M generality) Use the smallest possible floating-point or SIMD data type, to enable more parallelism with the use of a (longer) SIMD vector. For example, use single precision instead of double precision where possible.

User/Source Coding Rule 3. (M impact, ML generality) Arrange the nesting of loops so that the innermost nesting level is free of inter-iteration dependencies. Especially avoid the case where the store of data in an earlier iteration happens lexically after the load of that data in a future iteration, something which is called a lexically backward dependence.

The integer part of the SIMD instruction set extensions cover 8-bit, 16-bit and 32-bit operands. Not all SIMD operations are supported for 32 bits, meaning that some source code will not be able to be vectorized at all unless smaller operands are used.

User/Source Coding Rule 4. (M impact, ML generality) Avoid the use of conditional branches inside loops and consider using SSE instructions to eliminate branches.

User/Source Coding Rule 5. (M impact, ML generality) Keep induction (loop) variable expressions simple.

3.5.4 Optimization of Partially Vectorizable Code

Frequently, a program contains a mixture of vectorizable code and some routines that are non-vectorizable. A common situation of partially vectorizable code involves a loop structure which include mixtures of vectorized code and unvectorizable code. This situation is depicted in Figure 3-1.

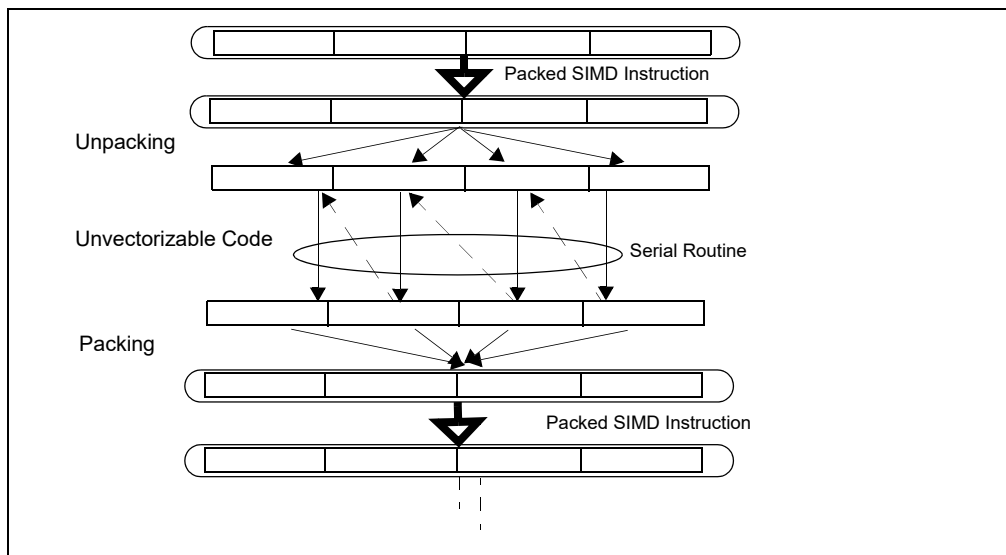

Figure 3-1. Generic Program Flow of Partially Vectorized Code

It generally consists of five stages within the loop:

- Prolog.
- Unpacking vectorized data structure into individual elements.
- Calling a non-vectorizable routine to process each element serially.
- Packing individual result into vectorized data structure.
- Epilog.

This section discusses techniques that can reduce the cost and bottleneck associated with the packing/unpacking stages in these partially vectorize code.

Example 3-28 shows a reference code template that is representative of partially vectorizable coding situations that also experience performance issues. The unvectorizable portion of code is represented generically by a sequence of calling a serial function named “foo” multiple times. This generic example is referred to as “shuffle with store forwarding”, because the problem generally involves an unpacking stage that shuffles data elements between register and memory, followed by a packing stage that can experience store forwarding issue.

There are more than one useful techniques that can reduce the store-forwarding bottleneck between the serialized portion and the packing stage. The following sub-sections presents alternate techniques to deal with the packing, unpacking, and parameter passing to serialized function calls.

Example 3-28. Reference Code Template for Partially Vectorizable Program

```
// Prolog //////////////////////////////////////
push ebp
mov ebp, esp

// Unpacking //////////////////////////////////////
sub ebp, 32
and ebp, 0xffffffff
movaps [ebp], xmm0

// Serial operations on components //////////
sub ebp, 4

mov eax, [ebp+4]
mov [ebp], eax
call foo
mov [ebp+16+4], eax

mov eax, [ebp+8]
mov [ebp], eax
call foo
mov [ebp+16+4+4], eax

mov eax, [ebp+12]
mov [ebp], eax
call foo
mov [ebp+16+8+4], eax

mov eax, [ebp+12+4]
mov [ebp], eax
call foo
mov [ebp+16+12+4], eax

// Packing //////////////////////////////////////
movaps xmm0, [ebp+16+4]

// Epilog //////////////////////////////////////
pop ebp
ret
```

3.5.4.1 Alternate Packing Techniques

The packing method implemented in the reference code of Example 3-28 will experience delay as it assembles 4 doubleword result from memory into an XMM register due to store-forwarding restrictions.

Three alternate techniques for packing, using different SIMD instruction to assemble contents in XMM registers are shown in Example 3-29. All three techniques avoid store-forwarding delay by satisfying the restrictions on data sizes between a preceding store and subsequent load operations.

Example 3-29. Three Alternate Packing Methods for Avoiding Store Forwarding Difficulty

Packing Method 1	Packing Method 2	Packing Method 3
<pre>movd xmm0, [ebp+16+4] movd xmm1, [ebp+16+8] movd xmm2, [ebp+16+12] movd xmm3, [ebp+12+16+4] punpckldq xmm0, xmm1 punpckldq xmm2, xmm3 punpckldq xmm0, xmm2</pre>	<pre>movd xmm0, [ebp+16+4] movd xmm1, [ebp+16+8] movd xmm2, [ebp+16+12] movd xmm3, [ebp+12+16+4] psllq xmm3, 32 orps xmm2, xmm3 psllq xmm1, 32 orps xmm0, xmm1 movlhps xmm0, xmm2</pre>	<pre>movd xmm0, [ebp+16+4] movd xmm1, [ebp+16+8] movd xmm2, [ebp+16+12] movd xmm3, [ebp+12+16+4] movlhps xmm1, xmm3 psllq xmm1, 32 movlhps xmm0, xmm2 orps xmm0, xmm1</pre>

3.5.4.2 Simplifying Result Passing

In Example 3-28, individual results were passed to the packing stage by storing to contiguous memory locations. Instead of using memory spills to pass four results, result passing may be accomplished by using either one or more registers. Using registers to simplify result passing and reduce memory spills can improve performance by varying degrees depending on the register pressure at runtime.

Example 3-30 shows the coding sequence that uses four extra XMM registers to reduce all memory spills of passing results back to the parent routine. However, software must observe the following conditions when using this technique:

- There is no register shortage.
- If the loop does not have many stores or loads but has many computations, this technique does not help performance. This technique adds work to the computational units, while the store and loads ports are idle.

Example 3-30. Using Four Registers to Reduce Memory Spills and Simplify Result Passing

<pre>mov eax, [ebp+4] mov [ebp], eax call foo movd xmm0, eax mov eax, [ebp+8] mov [ebp], eax call foo movd xmm1, eax</pre>

Example 3-30. Using Four Registers to Reduce Memory Spills and Simplify Result Passing (Contd.)

```

mov eax, [ebp+12]
mov [ebp], eax
call foo
movd xmm2, eax

mov eax, [ebp+12+4]
mov [ebp], eax
call foo
movd xmm3, eax

```

3.5.4.3 Stack Optimization

In Example 3-28, an input parameter was copied in turn onto the stack and passed to the non-vectorizable routine for processing. The parameter passing from consecutive memory locations can be simplified by a technique shown in Example 3-31.

Example 3-31. Stack Optimization Technique to Simplify Parameter Passing

```

call foo
mov [ebp+16], eax

add ebp, 4
call foo
mov [ebp+16], eax

add ebp, 4
call foo
mov [ebp+16], eax

add ebp, 4
call foo

```

Stack Optimization can only be used when:

- The serial operations are function calls. The function “foo” is declared as: INT FOO(INT A). The parameter is passed on the stack.
- The order of operation on the components is from last to first.

Note the call to FOO and the advance of EBP when passing the vector elements to FOO one by one from last to first.

3.5.4.4 Tuning Considerations

Tuning considerations for situations represented by looping of Example 3-28 include:

- Applying one of more of the following combinations:
 - Choose an alternate packing technique.
 - Consider a technique to simplify result-passing.
 - Consider the stack optimization technique to simplify parameter passing.
- Minimizing the average number of cycles to execute one iteration of the loop.
- Minimizing the per-iteration cost of the unpacking and packing operations.

The speed improvement by using the techniques discussed in this section will vary, depending on the choice of combinations implemented and characteristics of the non-vectorizable routine. For example, if the routine "foo" is short (representative of tight, short loops), the per-iteration cost of unpacking/packing tend to be smaller than situations where the non-vectorizable code contain longer operation or many dependencies. This is because many iterations of short, tight loop can be in flight in the execution core, so the per-iteration cost of packing and unpacking is only partially exposed and appear to cause very little performance degradation.

Evaluation of the per-iteration cost of packing/unpacking should be carried out in a methodical manner over a selected number of test cases, where each case may implement some combination of the techniques discussed in this section. The per-iteration cost can be estimated by:

- Evaluating the average cycles to execute one iteration of the test case.
- Evaluating the average cycles to execute one iteration of a base line loop sequence of non-vectorizable code.

Example 3-32 shows the base line code sequence that can be used to estimate the average cost of a loop that executes non-vectorizable routines.

Example 3-32. Base Line Code Sequence to Estimate Loop Overhead

```

push ebp
mov ebp, esp
sub ebp, 4

mov [ebp], edi
call foo

mov [ebp], edi
call foo

mov [ebp], edi
call foo

mov [ebp], edi
call foo

add ebp, 4
pop ebp
ret

```

The average per-iteration cost of packing/unpacking can be derived from measuring the execution times of a large number of iterations by:

$$((\text{Cycles to run TestCase}) - (\text{Cycles to run equivalent baseline sequence})) / (\text{Iteration count}).$$

For example, using a simple function that returns an input parameter (representative of tight, short loops), the per-iteration cost of packing/unpacking may range from slightly more than 7 cycles (the shuffle with store forwarding case, Example 3-28) to ~0.9 cycles (accomplished by several test cases). Across 27 test cases (consisting of one of the alternate packing methods, no result-simplification/simplification of either 1 or 4 results, no stack optimization or with stack optimization), the average per-iteration cost of packing/unpacking is about 1.7 cycles.

Generally speaking, packing method 2 and 3 (see Example 3-29) tend to be more robust than packing method 1; the optimal choice of simplifying 1 or 4 results will be affected by register pressure of the runtime and other relevant microarchitectural conditions.

Note that the numeric discussion of per-iteration cost of packing/unpacking is illustrative only. It will vary with test cases using a different base line code sequence and will generally increase if the non-vectorizable routine requires longer time to execute because the number of loop iterations that can reside in flight in the execution core decreases.

3.6 OPTIMIZING MEMORY ACCESSES

This section discusses guidelines for optimizing code and data memory accesses. The most important recommendations are:

- Execute load and store operations within available execution bandwidth.
- Enable forward progress of speculative execution.
- Enable store forwarding to proceed.
- Align data, paying attention to data layout and stack alignment.
- Place code and data on separate pages.
- Enhance data locality.
- Use prefetching and cacheability control instructions.
- Enhance code locality and align branch targets.
- Take advantage of write combining.

3.6.1 Load and Store Execution Bandwidth

Typically, loads and stores are the most frequent operations in a workload, up to 40% of the instructions in a workload carrying load or store intent are not uncommon. Each generation of microarchitecture provides multiple buffers to support executing load and store operations while there are instructions in flight. These buffers were comprised of 128-bit wide entries for the Sandy Bridge and Ivy Bridge microarchitectures. The size was increased to 256-bit in Haswell, Broadwell and Skylake Client microarchitectures; and to 512-bit in Skylake Server, Cascade Lake, Cascade Lake Advanced Performance, and Ice Lake Client microarchitectures. To maximize performance, it is best to use the largest width available in the platform.

3.6.1.1 Making Use of Load Bandwidth in Sandy Bridge Microarchitecture

While prior microarchitecture has one load port (port 2), Sandy Bridge microarchitecture can load from port 2 and port 3. Thus two load operations can be performed every cycle and doubling the load throughput of the code. This improves code that reads a lot of data and does not need to write out results to memory very often (Port 3 also handles store-address operation). To exploit this bandwidth, the data has to stay in the L1 data cache or it should be accessed sequentially, enabling the hardware prefetchers to bring the data to the L1 data cache in time.

Consider the following C code example of adding all the elements of an array:

```
int buff[BUFF_SIZE];
int sum = 0;

for (i=0;i<BUFF_SIZE;i++){
    sum+=buff[i];
}
```

Alternative 1 is the assembly code generated by the Intel compiler for this C code, using the optimization flag for Nehalem microarchitecture. The compiler vectorizes execution using Intel SSE instructions. In this code, each ADD operation uses the result of the previous ADD operation. This limits the throughput to one load and ADD operation per cycle. Alternative 2 is optimized for Sandy Bridge microarchitecture

by enabling it to use the additional load bandwidth. The code removes the dependency among ADD operations, by using two registers to sum the array values. Two load and two ADD operations can be executed every cycle.

Example 3-33. Optimizing for Load Port Bandwidth in Sandy Bridge Microarchitecture

Register dependency inhibits PADD execution	Reduce register dependency allow two load port to supply PADD execution
<pre> xor eax, eax pxor xmm0, xmm0 lea rsi, buff loop_start: padd xmm0, [rsi+4*rax] padd xmm0, [rsi+4*rax+16] padd xmm0, [rsi+4*rax+32] padd xmm0, [rsi+4*rax+48] padd xmm0, [rsi+4*rax+64] padd xmm0, [rsi+4*rax+80] padd xmm0, [rsi+4*rax+96] padd xmm0, [rsi+4*rax+112] add eax, 32 cmp eax, BUFF_SIZE jl loop_start sum_partials: movdqa xmm1, xmm0 psrldq xmm1, 8 padd xmm0, xmm1 movdqa xmm2, xmm0 psrldq xmm2, 4 padd xmm0, xmm2 movd [sum], xmm0 </pre>	<pre> xor eax, eax pxor xmm0, xmm0 pxor xmm1, xmm1 lea rsi, buff loop_start: padd xmm0, [rsi+4*rax] padd xmm1, [rsi+4*rax+16] padd xmm0, [rsi+4*rax+32] padd xmm1, [rsi+4*rax+48] padd xmm0, [rsi+4*rax+64] padd xmm1, [rsi+4*rax+80] padd xmm0, [rsi+4*rax+96] padd xmm1, [rsi+4*rax+112] add eax, 32 cmp eax, BUFF_SIZE jl loop_start sum_partials: padd xmm0, xmm1 movdqa xmm1, xmm0 psrldq xmm1, 8 padd xmm0, xmm1 movdqa xmm2, xmm0 psrldq xmm2, 4 padd xmm0, xmm2 movd [sum], xmm0 </pre>

3.6.1.2 L1D Cache Latency in Sandy Bridge Microarchitecture

Load latency from L1D cache may vary (see Table E-15 in Appendix E). The best case is 4 cycles, which apply to load operations to general purpose registers using one of the following:

- One register.
- A base register plus an offset that is smaller than 2048.

Consider the pointer-chasing code example in Example 3-34.

Example 3-34. Index versus Pointers in Pointer-Chasing Code

Traversing through indexes	Traversing through pointers
<pre data-bbox="203 308 764 594"> // C code example index = buffer.m_buff[index].next_index; // ASM example loop: shl rbx, 6 mov rbx, 0x20(rbx+rcx) dec rax cmp rax, -1 jne loop </pre>	<pre data-bbox="792 308 1414 594"> // C code example node = node->pNext; // ASM example loop: mov rdx, [rdx] dec rax cmp rax, -1 jne loop </pre>

The left side implements pointer chasing via traversing an index. Compiler then generates the code shown below addressing memory using base+index with an offset. The right side shows compiler generated code from pointer de-referencing code and uses only a base register.

The code on the right side is faster than the left side across Sandy Bridge microarchitecture and prior microarchitecture. However the code that traverses index will be slower on Sandy Bridge microarchitecture relative to prior microarchitecture.

3.6.1.3 Handling L1D Cache Bank Conflict

In Sandy Bridge microarchitecture, the internal organization of the L1D cache may manifest a situation when two load micro-ops whose addresses have a bank conflict. When a bank conflict is present between two load operations, the more recent one will be delayed until the conflict is resolved. A bank conflict happens when two simultaneous load operations have the same bit 2-5 of their linear address but they are not from the same set in the cache (bits 6 - 12).

Bank conflicts should be handled only if the code is bound by load bandwidth. Some bank conflicts do not cause any performance degradation since they are hidden by other performance limiters. Eliminating such bank conflicts does not improve performance.

The following example demonstrates bank conflict and how to modify the code and avoid them. It uses two source arrays with a size that is a multiple of cache line size. When loading an element from A and the counterpart element from B the elements have the same offset in their cache lines and therefore a bank conflict may happen.

The L1D Cache bank conflict issue does not apply to Haswell microarchitecture.

Example 3-35. Example of Bank Conflicts in L1D Cache and Remedy

<pre> int A[128]; int B[128]; int C[128]; for (i=0;i<128;i+=4){ C[i]=A[i]+B[i]; the loads from A[i] and B[i] collide C[i+1]=A[i+1]+B[i+1]; C[i+2]=A[i+2]+B[i+2]; C[i+3]=A[i+3]+B[i+3]; } // Code with Bank Conflicts xor rcx, rcx lea r11, A lea r12, B lea r13, C loop: lea esi, [rcx*4] movsxd rsi, esi mov edi, [r11+rsi*4] add edi, [r12+rsi*4] mov r8d, [r11+rsi*4+4] add r8d, [r12+rsi*4+4] mov r9d, [r11+rsi*4+8] add r9d, [r12+rsi*4+8] mov r10d, [r11+rsi*4+12] add r10d, [r12+rsi*4+12] mov [r13+rsi*4], edi inc ecx mov [r13+rsi*4+4], r8d mov [r13+rsi*4+8], r9d mov [r13+rsi*4+12], r10d cmp ecx, LEN jb loop </pre>	<pre> // Code without Bank Conflicts xor rcx, rcx lea r11, A lea r12, B lea r13, C loop: lea esi, [rcx*4] movsxd rsi, esi mov edi, [r11+rsi*4] mov r8d, [r11+rsi*4+4] add edi, [r12+rsi*4] add r8d, [r12+rsi*4+4] mov r9d, [r11+rsi*4+8] mov r10d, [r11+rsi*4+12] add r9d, [r12+rsi*4+8] add r10d, [r12+rsi*4+12] inc ecx mov [r13+rsi*4], edi mov [r13+rsi*4+4], r8d mov [r13+rsi*4+8], r9d mov [r13+rsi*4+12], r10d cmp ecx, LEN jb loop </pre>
---	--

3.6.2 Minimize Register Spills

When a piece of code has more live variables than the processor can keep in general purpose registers, a common method is to hold some of the variables in memory. This method is called register spill. The effect of L1D cache latency can negatively affect the performance of this code. The effect can be more pronounced if the address of register spills uses the slower addressing modes.

One option is to spill general purpose registers to XMM registers. This method is likely to improve performance also on previous processor generations. The following example shows how to spill a register to an XMM register rather than to memory.

Example 3-36. Using XMM Register in Lieu of Memory for Register Spills

Register spills into memory	Register spills into XMM
<pre> loop: mov rdx, [rsp+0x18] movdq xmm0, [rdx] movdq xmm1, [rsp+0x20] pcmpeqd xmm1, xmm0 pmovmskb eax, xmm1 test eax, eax jne end_loop movzx rcx, [rbx+0x60] add qword ptr[rsp+0x18], 0x10 add rdi, 0x4 movzx rdx, di sub rcx, 0x4 add rsi, 0x1d0 cmp rdx, rcx jle loop </pre>	<pre> movq xmm4, [rsp+0x18] mov rcx, 0x10 movq xmm5, rcx loop: movq rdx, xmm4 movdq xmm0, [rdx] movdq xmm1, [rsp+0x20] pcmpeqd xmm1, xmm0 pmovmskb eax, xmm1 test eax, eax jne end_loop movzx rcx, [rbx+0x60] padd xmm4, xmm5 add rdi, 0x4 movzx rdx, di sub rcx, 0x4 add rsi, 0x1d0 cmp rdx, rcx jle loop </pre>

3.6.3 Enhance Speculative Execution and Memory Disambiguation

Prior to Intel Core microarchitecture, when code contains both stores and loads, the loads cannot be issued before the address of the older stores is known. This rule ensures correct handling of load dependencies on preceding stores.

The Intel Core microarchitecture contains a mechanism that allows some loads to be executed speculatively in the presence of older unknown stores. The processor later checks if the load address overlapped with an older store whose address was unknown at the time the load executed. If the addresses do overlap, then the processor re-executes the load and all succeeding instructions.

Example 3-37 illustrates a situation that the compiler cannot be sure that “Ptr->Array” does not change during the loop. Therefore, the compiler cannot keep “Ptr->Array” in a register as an invariant and must read it again in every iteration. Although this situation can be fixed in software by a rewriting the code to require the address of the pointer is invariant, memory disambiguation improves performance without rewriting the code.

Example 3-37. Loads Blocked by Stores of Unknown Address

C code	Assembly sequence
<pre> struct AA { AA ** array; }; void nullify_array (AA *Ptr, DWORD Index, AA *ThisPtr) { while (Ptr->Array[--Index] != ThisPtr) { Ptr->Array[Index] = NULL ; }; }; </pre>	<pre> nullify_loop: mov dword ptr [eax], 0 mov edx, dword ptr [edi] sub ecx, 4 cmp dword ptr [ecx+edx], esi lea eax, [ecx+edx] jne nullify_loop </pre>

It is possible to disable speculative store bypass with the IA32_SPEC_CTRL.SSBD MSR. Additional information on this topic can be found here: <https://software.intel.com/security-software-guidance/insights>.

3.6.4 Store Forwarding

The processor's memory system only sends stores to memory (including cache) after store retirement. However, store data can be forwarded from a store to a subsequent load from the same address to give a much shorter store-load latency.

There are two kinds of requirements for store forwarding. If these requirements are violated, store forwarding cannot occur and the load must get its data from the cache (so the store must write its data back to the cache first). This incurs a penalty that is largely related to pipeline depth of the underlying micro-architecture.

The first requirement pertains to the size and alignment of the store-forwarding data. This restriction is likely to have high impact on overall application performance. Typically, a performance penalty due to violating this restriction can be prevented. The store-to-load forwarding restrictions vary from one microarchitecture to another. Several examples of coding pitfalls that cause store-forwarding stalls and solutions to these pitfalls are discussed in detail in Section 3.6.4.1, "Store-to-Load-Forwarding Restriction on Size and Alignment." The second requirement is the availability of data, discussed in Section 3.6.4.2, "Store-forwarding Restriction on Data Availability." A good practice is to eliminate redundant load operations.

It may be possible to keep a temporary scalar variable in a register and never write it to memory. Generally, such a variable must not be accessible using indirect pointers. Moving a variable to a register eliminates all loads and stores of that variable and eliminates potential problems associated with store forwarding. However, it also increases register pressure.

Load instructions tend to start chains of computation. Since the out-of-order engine is based on data dependence, load instructions play a significant role in the engine's ability to execute at a high rate. Eliminating loads should be given a high priority.

If a variable does not change between the time when it is stored and the time when it is used again, the register that was stored can be copied or used directly. If register pressure is too high, or an unseen function is called before the store and the second load, it may not be possible to eliminate the second load.

Assembly/Compiler Coding Rule 40. (H impact, M generality) *Pass parameters in registers instead of on the stack where possible. Passing arguments on the stack requires a store followed by a reload. While this sequence is optimized in hardware by providing the value to the load directly from*

the memory order buffer without the need to access the data cache if permitted by store-forwarding restrictions, floating-point values incur a significant latency in forwarding. Passing floating-point arguments in (preferably XMM) registers should save this long latency operation.

Parameter passing conventions may limit the choice of which parameters are passed in registers which are passed on the stack. However, these limitations may be overcome if the compiler has control of the compilation of the whole binary (using whole-program optimization).

3.6.4.1 Store-to-Load-Forwarding Restriction on Size and Alignment

Data size and alignment restrictions for store-forwarding apply to processors based on Intel Core microarchitecture, Intel Core 2 Duo, Intel Core Solo and Pentium M processors. The performance penalty for violating store-forwarding restrictions is less for shorter-pipelined machines.

Store-forwarding restrictions vary with each microarchitecture. The following rules help satisfy size and alignment restrictions for store forwarding:

Assembly/Compiler Coding Rule 41. (H impact, M generality) A load that forwards from a store must have the same address start point and therefore the same alignment as the store data.

Assembly/Compiler Coding Rule 42. (H impact, M generality) The data of a load which is forwarded from a store must be completely contained within the store data.

A load that forwards from a store must wait for the store's data to be written to the store buffer before proceeding, but other, unrelated loads need not wait.

Assembly/Compiler Coding Rule 43. (H impact, ML generality) If it is necessary to extract a non-aligned portion of stored data, read out the smallest aligned portion that completely contains the data and shift/mask the data as necessary. This is better than incurring the penalties of a failed store-forward.

Assembly/Compiler Coding Rule 44. (MH impact, ML generality) Avoid several small loads after large stores to the same area of memory by using a single large read and register copies as needed.

Example 3-38 depicts several store-forwarding situations in which small loads follow large stores. The first three load operations illustrate the situations described in Rule 44. However, the last load operation gets data from store-forwarding without problem.

Example 3-38. Situations Showing Small Loads After Large Store

```
mov [EBP], 'abcd'
mov AL, [EBP]      ; Not blocked - same alignment
mov BL, [EBP + 1] ; Blocked
mov CL, [EBP + 2] ; Blocked
mov DL, [EBP + 3] ; Blocked
mov AL, [EBP]      ; Not blocked - same alignment
                  ; n.b. passes older blocked loads
```

Example 3-39 illustrates a store-forwarding situation in which a large load follows several small stores. The data needed by the load operation cannot be forwarded because all of the data that needs to be forwarded is not contained in the store buffer. Avoid large loads after small stores to the same area of memory.

Example 3-39. Non-forwarding Example of Large Load After Small Store

```
mov [EBP], 'a'
mov [EBP + 1], 'b'
mov [EBP + 2], 'c'
mov [EBP + 3], 'd'
mov EAX, [EBP] ; Blocked
                ; The first 4 small store can be consolidated into
                ; a single DWORD store to prevent this non-forwarding
                ; situation.
```

Example 3-40 illustrates a stalled store-forwarding situation that may appear in compiler generated code. Sometimes a compiler generates code similar to that shown in Example 3-40 to handle a spilled byte to the stack and convert the byte to an integer value.

Example 3-40. A Non-forwarding Situation in Compiler Generated Code

```
mov DWORD PTR [esp+10h], 00000000h
mov BYTE PTR [esp+10h], bl
mov eax, DWORD PTR [esp+10h] ; Stall
and eax, 0xff                ; Converting back to byte value
```

Example 3-41 offers two alternatives to avoid the non-forwarding situation shown in Example 3-40.

Example 3-41. Two Ways to Avoid Non-forwarding Situation in Example 3-40

```
; A. Use MOVZ instruction to avoid large load after small
; store, when spills are ignored.
movz eax, bl                ; Replaces the last three instructions
; B. Use MOVZ instruction and handle spills to the stack
mov DWORD PTR [esp+10h], 00000000h
mov BYTE PTR [esp+10h], bl
movz eax, BYTE PTR [esp+10h] ; Not blocked
```

When moving data that is smaller than 64 bits between memory locations, 64-bit or 128-bit SIMD register moves are more efficient (if aligned) and can be used to avoid unaligned loads. Although floating-point registers allow the movement of 64 bits at a time, floating-point instructions should not be used for this purpose, as data may be inadvertently modified.

As an additional example, consider the cases in Example 3-42.

Example 3-42. Large and Small Load Stalls

```
; A. Large load stall
mov     mem, eax           ; Store dword to address "MEM"
mov     mem + 4, ebx       ; Store dword to address "MEM + 4"
fld     mem                ; Load qword at address "MEM", stalls
; B. Small Load stall
fstp   mem                ; Store qword to address "MEM"
mov     bx, mem+2          ; Load word at address "MEM + 2", stalls
mov     cx, mem+4          ; Load word at address "MEM + 4", stalls
```

In the first case (A), there is a large load after a series of small stores to the same area of memory (beginning at memory address MEM). The large load will stall.

The FLD must wait for the stores to write to memory before it can access all the data it requires. This stall can also occur with other data types (for example, when bytes or words are stored and then words or doublewords are read from the same area of memory).

In the second case (B), there is a series of small loads after a large store to the same area of memory (beginning at memory address MEM). The small loads will stall.

The word loads must wait for the quadword store to write to memory before they can access the data they require. This stall can also occur with other data types (for example, when doublewords or words are stored and then words or bytes are read from the same area of memory). This can be avoided by moving the store as far from the loads as possible.

Store forwarding restrictions for processors based on Intel Core microarchitecture is listed in Table 3-4.

Table 3-4. Store Forwarding Restrictions of Processors Based on Intel Core Microarchitecture

Store Alignment	Width of Store (bits)	Load Alignment (byte)	Width of Load (bits)	Store Forwarding Restriction
To Natural size	16	word aligned	8, 16	not stalled
To Natural size	16	not word aligned	8	stalled
To Natural size	32	dword aligned	8, 32	not stalled
To Natural size	32	not dword aligned	8	stalled
To Natural size	32	word aligned	16	not stalled
To Natural size	32	not word aligned	16	stalled
To Natural size	64	qword aligned	8, 16, 64	not stalled
To Natural size	64	not qword aligned	8, 16	stalled
To Natural size	64	dword aligned	32	not stalled
To Natural size	64	not dword aligned	32	stalled
To Natural size	128	dqword aligned	8, 16, 128	not stalled
To Natural size	128	not dqword aligned	8, 16	stalled
To Natural size	128	dword aligned	32	not stalled
To Natural size	128	not dword aligned	32	stalled
To Natural size	128	qword aligned	64	not stalled
To Natural size	128	not qword aligned	64	stalled
Unaligned, start byte 1	32	byte 0 of store	8, 16, 32	not stalled
Unaligned, start byte 1	32	not byte 0 of store	8, 16	stalled
Unaligned, start byte 1	64	byte 0 of store	8, 16, 32	not stalled
Unaligned, start byte 1	64	not byte 0 of store	8, 16, 32	stalled
Unaligned, start byte 1	64	byte 0 of store	64	stalled
Unaligned, start byte 7	32	byte 0 of store	8	not stalled
Unaligned, start byte 7	32	not byte 0 of store	8	not stalled
Unaligned, start byte 7	32	don't care	16, 32	stalled
Unaligned, start byte 7	64	don't care	16, 32, 64	stalled

3.6.4.2 Store-forwarding Restriction on Data Availability

The value to be stored must be available before the load operation can be completed. If this restriction is violated, the execution of the load will be delayed until the data is available. This delay causes some execution resources to be used unnecessarily, and that can lead to sizable but non-deterministic delays. However, the overall impact of this problem is much smaller than that from violating size and alignment requirements.

In modern microarchitectures, hardware predicts when loads are dependent on and get their data forwarded from preceding stores. These predictions can significantly improve performance. However, if a load is scheduled too soon after the store it depends on or if the generation of the data to be stored is delayed, there can be a significant penalty.

There are several cases in which data is passed through memory, and the store may need to be separated from the load:

- Spills, save and restore registers in a stack frame.
- Parameter passing.
- Global and volatile variables.

- Type conversion between integer and floating-point.
- When compilers do not analyze code that is inlined, forcing variables that are involved in the interface with inlined code to be in memory, creating more memory variables and preventing the elimination of redundant loads.

Assembly/Compiler Coding Rule 45. (H impact, MH generality) *Where it is possible to do so without incurring other penalties, prioritize the allocation of variables to registers, as in register allocation and for parameter passing, to minimize the likelihood and impact of store-forwarding problems. Try not to store-forward data generated from a long latency instruction - for example, MUL or DIV. Avoid store-forwarding data for variables with the shortest store-load distance. Avoid store-forwarding data for variables with many and/or long dependence chains, and especially avoid including a store forward on a loop-carried dependence chain.*

Example 3-43 shows an example of a loop-carried dependence chain.

Example 3-43. Loop-carried Dependence Chain

```
for ( i = 0; i < MAX; i++ ) {
    a[i] = b[i] * foo;
    foo = a[i] / 3;
} // foo is a loop-carried dependence.
```

Assembly/Compiler Coding Rule 46. (M impact, MH generality) *Calculate store addresses as early as possible to avoid having stores block loads.*

3.6.5 Data Layout Optimizations

User/Source Coding Rule 6. (H impact, M generality) *Pad data structures defined in the source code so that every data element is aligned to a natural operand size address boundary.*

If the operands are packed in a SIMD instruction, align to the packed element size (64-bit or 128-bit).

Align data by providing padding inside structures and arrays. Programmers can reorganize structures and arrays to minimize the amount of memory wasted by padding. However, compilers might not have this freedom. The C programming language, for example, specifies the order in which structure elements are allocated in memory. For more information, see Section 5.4, “Stack and Data Alignment.”

Example 3-44 shows how a data structure could be rearranged to reduce its size.

Example 3-44. Rearranging a Data Structure

```
struct unpacked { /* Fits in 20 bytes due to padding */
    int    a;
    char   b;
    int    c;
    char   d;
    int    e;
};

struct packed { /* Fits in 16 bytes */
    int    a;
    int    c;
    int    e;
    char   b;
    char   d;
}
```

Cache line size of 64 bytes can impact streaming applications (for example, multimedia). These reference and use data only once before discarding it. Data accesses which sparsely utilize the data within a

cache line can result in less efficient utilization of system memory bandwidth. For example, arrays of structures can be decomposed into several arrays to achieve better packing, as shown in Example 3-45.

Example 3-45. Decomposing an Array

```

struct {      /* 1600 bytes */
    int  a, c, e;
    char b, d;
} array_of_struct [100];

struct {      /* 1400 bytes */
    int  a[100], c[100], e[100];
    char b[100], d[100];
} struct_of_array;

struct {      /* 1200 bytes */
    int  a, c, e;
} hybrid_struct_of_array_ace[100];

struct {      /* 200 bytes */
    char b, d;
} hybrid_struct_of_array_bd[100];

```

The efficiency of such optimizations depends on usage patterns. If the elements of the structure are all accessed together but the access pattern of the array is random, then `ARRAY_OF_STRUCT` avoids unnecessary prefetch even though it wastes memory.

However, if the access pattern of the array exhibits locality (for example, if the array index is being swept through) then processors with hardware prefetchers will prefetch data from `STRUCT_OF_ARRAY`, even if the elements of the structure are accessed together.

When the elements of the structure are not accessed with equal frequency, such as when element A is accessed ten times more often than the other entries, then `STRUCT_OF_ARRAY` not only saves memory, but it also prevents fetching unnecessary data items B, C, D, and E.

Using `STRUCT_OF_ARRAY` also enables the use of the SIMD data types by the programmer and the compiler.

Note that `STRUCT_OF_ARRAY` can have the disadvantage of requiring more independent memory stream references. This can require the use of more prefetches and additional address generation calculations. It can also have an impact on DRAM page access efficiency. An alternative, `HYBRID_STRUCT_OF_ARRAY` blends the two approaches. In this case, only 2 separate address streams are generated and referenced: 1 for `HYBRID_STRUCT_OF_ARRAY_ACE` and 1 for `HYBRID_STRUCT_OF_ARRAY_BD`. The second alternative also prevents fetching unnecessary data — assuming that (1) the variables A, C and E are always used together, and (2) the variables B and D are always used together, but not at the same time as A, C and E.

The hybrid approach ensures:

- Simpler/fewer address generations than `STRUCT_OF_ARRAY`.
- Fewer streams, which reduces DRAM page misses.
- Fewer prefetches due to fewer streams.
- Efficient cache line packing of data elements that are used concurrently.

Assembly/Compiler Coding Rule 47. (H impact, M generality) *Try to arrange data structures such that they permit sequential access.*

If the data is arranged into a set of streams, the automatic hardware prefetcher can prefetch data that will be needed by the application, reducing the effective memory latency. If the data is accessed in a non-sequential manner, the automatic hardware prefetcher cannot prefetch the data. The prefetcher can recognize up to eight concurrent streams. See Chapter 9, “Optimizing Cache Usage,” for more information on the hardware prefetcher.

User/Source Coding Rule 7. (M impact, L generality) *Beware of false sharing within a cache line (64 bytes).*

3.6.6 Stack Alignment

Performance penalty of unaligned access to the stack happens when a memory reference splits a cache line. This means that one out of eight spatially consecutive unaligned quadword accesses is always penalized, similarly for one out of 4 consecutive, non-aligned double-quadword accesses, etc.

Aligning the stack may be beneficial any time there are data objects that exceed the default stack alignment of the system. For example, on 32/64bit Linux, and 64bit Windows, the default stack alignment is 16 bytes, while 32bit Windows is 4 bytes.

Assembly/Compiler Coding Rule 48. (H impact, M generality) *Make sure that the stack is aligned at the largest multi-byte granular data type boundary matching the register width.*

Aligning the stack typically requires the use of an additional register to track across a padded area of unknown amount. There is a trade-off between causing unaligned memory references that spanned across a cache line and causing extra general purpose register spills.

The assembly level technique to implement dynamic stack alignment may depend on compilers, and specific OS environment. The reader may wish to study the assembly output from a compiler of interest.

Example 3-46. Examples of Dynamical Stack Alignment

```
// 32-bit environment
push    ebp ; save ebp
mov     ebp, esp ; ebp now points to incoming parameters
andl   esp, $-<N> ;align esp to N byte boundary
sub     esp, $<stack_size>; reserve space for new stack frame
.      ; parameters must be referenced off of ebp
mov     esp, ebp ; restore esp
pop     ebp ; restore ebp

// 64-bit environment
sub     esp, $<stack_size +N>
mov     r13, $<offset_of_aligned_section_in_stack>
andl   r13, $-<N> ; r13 point to aligned section in stack
.      ;use r13 as base for aligned data
```

If for some reason it is not possible to align the stack for 64-bits, the routine should access the parameter and save it into a register or known aligned storage, thus incurring the penalty only once.

3.6.7 Capacity Limits and Aliasing in Caches

There are cases in which addresses with a given stride will compete for some resource in the memory hierarchy.

Typically, caches are implemented to have multiple ways of set associativity, with each way consisting of multiple sets of cache lines (or sectors in some cases). Multiple memory references that compete for the same set of each way in a cache can cause a capacity issue. There are aliasing conditions that apply to specific microarchitectures. Note that first-level cache lines are 64 bytes. Thus, the least significant 6 bits are not considered in alias comparisons.

3.6.8 Mixing Code and Data

The aggressive prefetching and pre-decoding of instructions by Intel processors have two related effects:

- Self-modifying code works correctly, according to the Intel architecture processor requirements, but incurs a significant performance penalty. Avoid self-modifying code if possible.
- Placing writable data in the code segment might be impossible to distinguish from self-modifying code. Writable data in the code segment might suffer the same performance penalty as self-modifying code.

Assembly/Compiler Coding Rule 49. (M impact, L generality) *If (hopefully read-only) data must occur on the same page as code, avoid placing it immediately after an indirect jump. For example, follow an indirect jump with its mostly likely target, and place the data after an unconditional branch.*

Tuning Suggestion 1. *In rare cases, a performance problem may be caused by executing data on a code page as instructions. This is very likely to happen when execution is following an indirect branch that is not resident in the trace cache. If this is clearly causing a performance problem, try moving the data elsewhere, or inserting an illegal opcode or a PAUSE instruction immediately after the indirect branch. Note that the latter two alternatives may degrade performance in some circumstances.*

Assembly/Compiler Coding Rule 50. (H impact, L generality) *Always put code and data on separate pages. Avoid self-modifying code wherever possible. If code is to be modified, try to do it all at once and make sure the code that performs the modifications and the code being modified are on separate 4-KByte pages or on separate aligned 1-KByte subpages.*

3.6.8.1 Self-modifying Code

Self-modifying code (SMC) that ran correctly on Pentium III processors and prior implementations will run correctly on subsequent implementations. SMC and cross-modifying code (when multiple processors in a multiprocessor system are writing to a code page) should be avoided when high performance is desired.

Software should avoid writing to a code page in the same 1-KByte subpage that is being executed or fetching code in the same 2-KByte subpage of that is being written. In addition, sharing a page containing directly or speculatively executed code with another processor as a data page can trigger an SMC condition that causes the entire pipeline of the machine and the trace cache to be cleared. This is due to the self-modifying code condition.

Dynamic code need not cause the SMC condition if the code written fills up a data page before that page is accessed as code. Dynamically-modified code (for example, from target fix-ups) is likely to suffer from the SMC condition and should be avoided where possible. Avoid the condition by introducing indirect branches and using data tables on data pages (not code pages) using register-indirect calls.

3.6.8.2 Position Independent Code

Position independent code often needs to obtain the value of the instruction pointer. Example 3-47a shows one technique to put the value of IP into the ECX register by issuing a CALL without a matching RET. Example 3-47b shows an alternative technique to put the value of IP into the ECX register using a matched pair of CALL/RET.

Example 3-47. Instruction Pointer Query Techniques

```

a) Using call without return to obtain IP does not corrupt the RSB
   call _label; return address pushed is the IP of next instruction
_label:
   pop ECX; IP of this instruction is now put into ECX

b) Using matched call/ret pair

   call _lblcx;
   ... ; ECX now contains IP of this instruction
   ...
_labelcx
   mov ecx, [esp];
   ret

```

3.6.9 Write Combining

Write combining (WC) improves performance in two ways:

- On a write miss to the first-level cache, it allows multiple stores to the same cache line to occur before that cache line is read for ownership (RFO) from further out in the cache/memory hierarchy. Then the rest of line is read, and the bytes that have not been written are combined with the unmodified bytes in the returned line.
- Write combining allows multiple writes to be assembled and written further out in the cache hierarchy as a unit. This saves port and bus traffic. Saving traffic is particularly important for avoiding partial writes to uncached memory.

Processors based on Intel Core microarchitecture have eight write-combining buffers in each core. Beginning with Nehalem microarchitecture, there are 10 buffers available for write-combining. Beginning with Ice Lake Client microarchitecture, there are 12 buffers available for write-combining.

Assembly/Compiler Coding Rule 51. (H impact, L generality) *If an inner loop writes to more than four arrays (four distinct cache lines), apply loop fission to break up the body of the loop such that only four arrays are being written to in each iteration of each of the resulting loops.*

Write combining buffers are used for stores of all memory types. They are particularly important for writes to uncached memory: writes to different parts of the same cache line can be grouped into a single, full-cache-line bus transaction instead of going across the bus (since they are not cached) as several partial writes. Avoiding partial writes can have a significant impact on bus bandwidth-bound graphics applications, where graphics buffers are in uncached memory. Separating writes to uncached memory and writes to writeback memory into separate phases can assure that the write combining buffers can fill before getting evicted by other write traffic. Eliminating partial write transactions has been found to have performance impact on the order of 20% for some applications. Because the cache lines are 64 bytes, a write to the bus for 63 bytes will result in partial bus transactions.

When coding functions that execute simultaneously on two threads, reducing the number of writes that are allowed in an inner loop will help take full advantage of write-combining store buffers. For write-combining buffer recommendations for Hyper-Threading Technology, see Chapter 11, “Multicore and Hyper-Threading Technology.”

Store ordering and visibility are also important issues for write combining. When a write to a write-combining buffer for a previously-unwritten cache line occurs, there will be a read-for-ownership (RFO). If a subsequent write happens to another write-combining buffer, a separate RFO may be caused for that cache line. Subsequent writes to the first cache line and write-combining buffer will be delayed until the second RFO has been serviced to guarantee properly ordered visibility of the writes. If the memory type for the writes is write-combining, there will be no RFO since the line is not cached, and there is no such delay. For details on write-combining, see Chapter 9, “Optimizing Cache Usage.”

3.6.10 Locality Enhancement

Locality enhancement can reduce data traffic originating from an outer-level sub-system in the cache/memory hierarchy. This is to address the fact that the access-cost in terms of cycle-count from an outer level will be more expensive than from an inner level. Typically, the cycle-cost of accessing a given cache level (or memory system) varies across different microarchitectures, processor implementations, and platform components. It may be sufficient to recognize the relative data access cost trend by locality rather than to follow a large table of numeric values of cycle-costs, listed per locality, per processor/platform implementations, etc. The general trend is typically that access cost from an outer sub-system may be approximately 3-10X more expensive than accessing data from the immediate inner level in the cache/memory hierarchy, assuming similar degrees of data access parallelism.

Thus locality enhancement should start with characterizing the dominant data traffic locality. Section A, “Application Performance Tools,” describes some techniques that can be used to determine the dominant data traffic locality for any workload.

Even if cache miss rates of the last level cache may be low relative to the number of cache references, processors typically spend a sizable portion of their execution time waiting for cache misses to be serviced. Reducing cache misses by enhancing a program’s locality is a key optimization. This can take several forms:

- Blocking to iterate over a portion of an array that will fit in the cache (with the purpose that subsequent references to the data-block [or tile] will be cache hit references).
- Loop interchange to avoid crossing cache lines or page boundaries.
- Loop skewing to make accesses contiguous.

Locality enhancement to the last level cache can be accomplished with sequencing the data access pattern to take advantage of hardware prefetching. This can also take several forms:

- Transformation of a sparsely populated multi-dimensional array into a one-dimension array such that memory references occur in a sequential, small-stride pattern that is friendly to the hardware prefetch (see Section E.2.5.4, “Data Prefetching” in Appendix E).
- Optimal tile size and shape selection can further improve temporal data locality by increasing hit rates into the last level cache and reduce memory traffic resulting from the actions of hardware prefetching (see Section 9.5.11, “Hardware Prefetching and Cache Blocking Techniques”).

It is important to avoid operations that work against locality-enhancing techniques. Using the lock prefix heavily can incur large delays when accessing memory, regardless of whether the data is in the cache or in system memory.

User/Source Coding Rule 8. (H impact, H generality) *Optimization techniques such as blocking, loop interchange, loop skewing, and packing are best done by the compiler. Optimize data structures either to fit in one-half of the first-level cache or in the second-level cache; turn on loop optimizations in the compiler to enhance locality for nested loops.*

Optimizing for one-half of the first-level cache will bring the greatest performance benefit in terms of cycle-cost per data access. If one-half of the first-level cache is too small to be practical, optimize for the second-level cache. Optimizing for a point in between (for example, for the entire first-level cache) will likely not bring a substantial improvement over optimizing for the second-level cache.

3.6.11 Non-Temporal Store Bus Traffic

Peak system bus bandwidth is shared by several types of bus activities, including reads (from memory), reads for ownership (of a cache line), and writes. The data transfer rate for bus write transactions is higher if 64 bytes are written out to the bus at a time.

Typically, bus writes to Writeback (WB) memory must share the system bus bandwidth with read-for-ownership (RFO) traffic. Non-temporal stores do not require RFO traffic; they do require care in managing the access patterns in order to ensure 64 bytes are evicted at once (rather than evicting several chunks).

Although the data bandwidth of full 64-byte bus writes due to non-temporal stores is twice that of bus writes to WB memory, transferring several chunks wastes bus request bandwidth and delivers significantly lower data bandwidth. This difference is depicted in Examples 3-48 and 3-49.

Example 3-48. Using Non-temporal Stores and 64-byte Bus Write Transactions

```
#define STRIDESIZE 256
lea ecx, p64byte_Aligned
mov edx, ARRAY_LEN
xor eax, eax
sloop:
movntps XMMWORD ptr [ecx + eax], xmm0
movntps XMMWORD ptr [ecx + eax+16], xmm0
movntps XMMWORD ptr [ecx + eax+32], xmm0
movntps XMMWORD ptr [ecx + eax+48], xmm0
; 64 bytes is written in one bus transaction
add eax, STRIDESIZE
cmp eax, edx
jl sloop
```

Example 3-49. On-temporal Stores and Partial Bus Write Transactions

```
#define STRIDESIZE 256
Lea ecx, p64byte_Aligned
Mov edx, ARRAY_LEN
Xor eax, eax
sloop:
movntps XMMWORD ptr [ecx + eax], xmm0
movntps XMMWORD ptr [ecx + eax+16], xmm0
movntps XMMWORD ptr [ecx + eax+32], xmm0

; Storing 48 bytes results in several bus partial transactions
add eax, STRIDESIZE
cmp eax, edx
jl sloop
```

3.7 PREFETCHING

Recent Intel processor families employ several prefetching mechanisms to accelerate the movement of data or code and improve performance:

- Hardware instruction prefetcher.
- Software prefetch for data.
- Hardware prefetch for cache lines of data or instructions.

3.7.1 Hardware Instruction Fetching and Software Prefetching

Software prefetching requires a programmer to use PREFETCH hint instructions and anticipate some suitable timing and location of cache misses.

Software PREFETCH operations work the same way as do load from memory operations, with the following exceptions:

- Software PREFETCH instructions retire after virtual to physical address translation is completed.
- If an exception, such as page fault, is required to prefetch the data, then the software prefetch instruction retires without prefetching data.
- Avoid specifying a NULL address for software prefetches.

3.7.2 Hardware Prefetching for First-Level Data Cache

The hardware prefetching mechanism for L1 in Intel Core microarchitecture is discussed in Section E.3.4.2 in Appendix E.

Example 3-50 depicts a technique to trigger hardware prefetch. The code demonstrates traversing a linked list and performing some computational work on 2 members of each element that reside in 2 different cache lines. Each element is of size 192 bytes. The total size of all elements is larger than can be fitted in the L2 cache.

Example 3-50. Using DCU Hardware Prefetch

Original code	Modified sequence benefit from prefetch
<pre> mov ebx, DWORD PTR [First] xor eax, eax scan_list: mov eax, [ebx+4] mov ecx, 60 do_some_work_1: add eax, eax and eax, 6 sub ecx, 1 jnz do_some_work_1 mov eax, [ebx+64] mov ecx, 30 do_some_work_2: add eax, eax and eax, 6 sub ecx, 1 jnz do_some_work_2 </pre>	<pre> mov ebx, DWORD PTR [First] xor eax, eax scan_list: mov eax, [ebx+4] mov eax, [ebx+4] mov eax, [ebx+4] mov ecx, 60 do_some_work_1: add eax, eax and eax, 6 sub ecx, 1 jnz do_some_work_1 mov eax, [ebx+64] mov ecx, 30 do_some_work_2: add eax, eax and eax, 6 sub ecx, 1 jnz do_some_work_2 </pre>

Example 3-50. Using DCU Hardware Prefetch (Contd.)

Original code	Modified sequence benefit from prefetch
<pre>mov ebx, [ebx] test ebx, ebx jnz scan_list</pre>	<pre>mov ebx, [ebx] test ebx, ebx jnz scan_list</pre>

The additional instructions to load data from one member in the modified sequence can trigger the DCU hardware prefetch mechanisms to prefetch data in the next cache line, enabling the work on the second member to complete sooner.

Software can gain from the first-level data cache prefetchers in two cases:

- If data is not in the second-level cache, the first-level data cache prefetcher enables early trigger of the second-level cache prefetcher.
- If data is in the second-level cache and not in the first-level data cache, then the first-level data cache prefetcher triggers earlier data bring-up of sequential cache line to the first-level data cache.

There are situations that software should pay attention to a potential side effect of triggering unnecessary DCU hardware prefetches. If a large data structure with many members spanning many cache lines is accessed in ways that only a few of its members are actually referenced, but there are multiple pair accesses to the same cache line. The DCU hardware prefetcher can trigger fetching of cache lines that are not needed. In Example 3-51, references to the "Pts" array and "AltPts" will trigger DCU prefetch to fetch additional cache lines that won't be needed. If significant negative performance impact is detected due to DCU hardware prefetch on a portion of the code, software can try to reduce the size of that contemporaneous working set to be less than half of the L2 cache.

Example 3-51. Avoid Causing DCU Hardware Prefetch to Fetch Un-needed Lines

```
while ( CurrBond != NULL )
{
  MyATOM *a1 = CurrBond->At1 ;
  MyATOM *a2 = CurrBond->At2 ;

  if ( a1->CurrStep <= a1->LastStep &&
      a2->CurrStep <= a2->LastStep
    )
  {
    a1->CurrStep++ ;
    a2->CurrStep++ ;

    double ux = a1->Pts[0].x - a2->Pts[0].x ;
    double uy = a1->Pts[0].y - a2->Pts[0].y ;
    double uz = a1->Pts[0].z - a2->Pts[0].z ;
    a1->AuxPts[0].x += ux ;
    a1->AuxPts[0].y += uy ;
    a1->AuxPts[0].z += uz ;
```

Example 3-51. Avoid Causing DCU Hardware Prefetch to Fetch Un-needed Lines (Contd.)

```

a2->AuxPts[0].x += ux ;
a2->AuxPts[0].y += uy ;
a2->AuxPts[0].z += uz ;
};
CurrBond = CurrBond->Next ;
};

```

To fully benefit from these prefetchers, organize and access the data using one of the following methods:

Method 1:

- Organize the data so consecutive accesses can usually be found in the same 4-KByte page.
- Access the data in constant strides forward or backward IP Prefetcher.

Method 2:

- Organize the data in consecutive lines.
- Access the data in increasing addresses, in sequential cache lines.

Example 3-52 demonstrates accesses to sequential cache lines that can benefit from the first-level cache prefetcher.

Example 3-52. Technique For Using L1 Hardware Prefetch

```

unsigned int *p1, j, a, b;
for (j = 0; j < num; j += 16)
{
a = p1[j];
b = p1[j+1];
// Use these two values
}

```

By elevating the load operations from memory to the beginning of each iteration, it is likely that a significant part of the latency of the pair cache line transfer from memory to the second-level cache will be in parallel with the transfer of the first cache line.

The IP prefetcher uses only the lower 8 bits of the address to distinguish a specific address. If the code size of a loop is bigger than 256 bytes, two loads may appear similar in the lowest 8 bits and the IP prefetcher will be restricted. Therefore, if you have a loop bigger than 256 bytes, make sure that no two loads have the same lowest 8 bits in order to use the IP prefetcher.

3.7.3 Hardware Prefetching for Second-Level Cache

The Intel Core microarchitecture contains two second-level cache prefetchers:

- **Streamer** — Loads data or instructions from memory to the second-level cache. To use the streamer, organize the data or instructions in blocks of 128 bytes, aligned on 128 bytes. The first access to one of the two cache lines in this block while it is in memory triggers the streamer to prefetch the pair line. To software, the L2 streamer's functionality is similar to the adjacent cache line prefetch mechanism found in processors based on Intel NetBurst microarchitecture.
- **Data prefetch logic (DPL)** — DPL and L2 Streamer are triggered only by writeback memory type. They prefetch only inside page boundary (4 KBytes). Both L2 prefetchers can be triggered by software prefetch instructions and by prefetch request from DCU prefetchers. DPL can also be triggered by read for ownership (RFO) operations. The L2 Streamer can also be triggered by DPL requests for L2 cache misses.

Software can gain from organizing data both according to the instruction pointer and according to line strides. For example, for matrix calculations, columns can be prefetched by IP-based prefetches, and rows can be prefetched by DPL and the L2 streamer.

3.7.4 Cacheability Instructions

SSE2 provides additional cacheability instructions that extend those provided in SSE. The new cacheability instructions include:

- New streaming store instructions.
- New cache line flush instruction.
- New memory fencing instructions.

For more information, see Chapter 9, “Optimizing Cache Usage.”

3.7.5 REP Prefix and Data Movement

The REP prefix is commonly used with string move instructions for memory related library functions such as MEMCPY (using REP MOVSD) or MEMSET (using REP STOS). These STRING/MOV instructions with the REP prefixes are implemented in MS-ROM and have several implementation variants with different performance levels.

The specific variant of the implementation is chosen at execution time based on data layout, alignment and the counter (ECX) value. For example, MOVSB/STOSB with the REP prefix should be used with counter value less than or equal to three for best performance.

String MOVE/STORE instructions have multiple data granularities. For efficient data movement, larger data granularities are preferable. This means better efficiency can be achieved by decomposing an arbitrary counter value into a number of doublewords plus single byte moves with a count value less than or equal to 3.

Because software can use SIMD data movement instructions to move 16 bytes at a time, the following paragraphs discuss general guidelines for designing and implementing high-performance library functions such as MEMCPY(), MEMSET(), and MEMMOVE(). Four factors are to be considered:

- **Throughput per iteration** — If two pieces of code have approximately identical path lengths, efficiency favors choosing the instruction that moves larger pieces of data per iteration. Also, smaller code size per iteration will in general reduce overhead and improve throughput. Sometimes, this may involve a comparison of the relative overhead of an iterative loop structure versus using REP prefix for iteration.
- **Address alignment** — Data movement instructions with highest throughput usually have alignment restrictions, or they operate more efficiently if the destination address is aligned to its natural data size. Specifically, 16-byte moves need to ensure the destination address is aligned to 16-byte boundaries, and 8-bytes moves perform better if the destination address is aligned to 8-byte boundaries. Frequently, moving at doubleword granularity performs better with addresses that are 8-byte aligned.
- **REP string move vs. SIMD move** — Implementing general-purpose memory functions using SIMD extensions usually requires adding some prolog code to ensure the availability of SIMD instructions, preamble code to facilitate aligned data movement requirements at runtime. Throughput comparison must also take into consideration the overhead of the prolog when considering a REP string implementation versus a SIMD approach.
- **Cache eviction** — If the amount of data to be processed by a memory routine approaches half the size of the last level on-die cache, temporal locality of the cache may suffer. Using streaming store instructions (for example: MOVNTQ, MOVNTDQ) can minimize the effect of flushing the cache. The threshold to start using a streaming store depends on the size of the last level cache. Determine the size using the deterministic cache parameter leaf of CPUID.

Techniques for using streaming stores for implementing a MEMSET()-type library must also consider that the application can benefit from this technique only if it has no immediate need to

reference the target addresses. This assumption is easily upheld when testing a streaming-store implementation on a micro-benchmark configuration, but violated in a full-scale application situation.

When applying general heuristics to the design of general-purpose, high-performance library routines, the following guidelines can be useful when optimizing an arbitrary counter value N and address alignment. Different techniques may be necessary for optimal performance, depending on the magnitude of N:

- When N is less than some small count (where the small count threshold will vary between microarchitectures -- empirically, 8 may be a good value when optimizing for Intel NetBurst microarchitecture), each case can be coded directly without the overhead of a looping structure. For example, 11 bytes can be processed using two MOVSD instructions explicitly and a MOVSB with REP counter equaling 3.
- When N is not small but still less than some threshold value (which may vary for different microarchitectures, but can be determined empirically), an SIMD implementation using run-time CPUID and alignment prolog will likely deliver less throughput due to the overhead of the prolog. A REP string implementation should favor using a REP string of doublewords. To improve address alignment, a small piece of prolog code using MOVSB/STOSB with a count less than 4 can be used to peel off the non-aligned data moves before starting to use MOVSD/STOSD.
- When N is less than half the size of last level cache, throughput consideration may favor either:
 - An approach using a REP string with the largest data granularity because a REP string has little overhead for loop iteration, and the branch misprediction overhead in the prolog/epilogue code to handle address alignment is amortized over many iterations.
 - An iterative approach using the instruction with largest data granularity, where the overhead for SIMD feature detection, iteration overhead, and prolog/epilogue for alignment control can be minimized. The trade-off between these approaches may depend on the microarchitecture.

An example of MEMSET() implemented using stosd for arbitrary counter value with the destination address aligned to doubleword boundary in 32-bit mode is shown in Example 3-53.

- When N is larger than half the size of the last level cache, using 16-byte granularity streaming stores with prolog/epilog for address alignment will likely be more efficient, if the destination addresses will not be referenced immediately afterwards.

Example 3-53. REP STOSD with Arbitrary Count Size and 4-Byte-Aligned Destination

A 'C' example of Memset()	Equivalent Implementation Using REP STOSD
<pre>void memset(void *dst,int c,size_t size) { char *d = (char *)dst; size_t i; for (i=0;i<size;i++) *d++ = (char)c; }</pre>	<pre>push edi movzx eax, byte ptr [esp+12] mov ecx, eax shl ecx, 8 or ecx, eax mov ecx, eax shl ecx, 16 or eax, ecx mov edi, [esp+8] ; 4-byte aligned mov ecx, [esp+16] ; byte count shr ecx, 2 ; do dword cmp ecx, 127 jle _main test edi, 4 jz _main stosd ;peel off one dword dec ecx</pre>

Example 3-53. REP STOSD with Arbitrary Count Size and 4-Byte-Aligned Destination (Contd.)

A 'C' example of Memset()	Equivalent Implementation Using REP STOSD
	<pre> _main: ; 8-byte aligned rep stosd mov ecx, [esp + 16] and ecx, 3 ; do count <= 3 rep stosb ; optimal with <= 3 pop edi ret </pre>

Memory routines in the runtime library generated by Intel compilers are optimized across a wide range of address alignments, counter values, and microarchitectures. In most cases, applications should take advantage of the default memory routines provided by Intel compilers.

In some situations, the byte count of the data is known by the context (as opposed to being known by a parameter passed from a call), and one can take a simpler approach than those required for a general-purpose library routine. For example, if the byte count is also small, using REP MOVSB/STOSB with a count less than four can ensure good address alignment and loop-unrolling to finish the remaining data; using MOVSD/STOSD can reduce the overhead associated with iteration.

Using a REP prefix with string move instructions can provide high performance in the situations described above. However, using a REP prefix with string scan instructions (SCASB, SCASW, SCASD, SCASQ) or compare instructions (CMPSB, CMPSW, SMPSD, SMPSQ) is not recommended for high performance. Consider using SIMD instructions instead.

3.7.6 Enhanced REP MOVSB and STOSB Operation

Beginning with processors based on Ivy Bridge microarchitecture, REP string operation using MOVSB and STOSB can provide both flexible and high-performance REP string operations for software in common situations like memory copy and set operations. Processors that provide enhanced MOVSB/STOSB operations are enumerated by the CPUID feature flag: CPUID:(EAX=7H, ECX=0H):EBX.[bit 9] = 1.

3.7.6.1 Fast Short REP MOVSB

Beginning with processors based on Ice Lake Client microarchitecture, REP MOVSB performance of short operations is enhanced. The enhancement applies to string lengths between 1 and 128 bytes long. Support for fast-short REP MOVSB is enumerated by the CPUID feature flag: CPUID [EAX=7H, ECX=0H].EDX.FAST_SHORT_REP_MOVSB[bit 4] = 1. There is no change in the REP STOS performance.

3.7.6.2 Memcpy Considerations

The interface for the standard library function memcpy introduces several factors (e.g. length, alignment of the source buffer and destination) that interact with microarchitecture to determine the performance characteristics of the implementation of the library function. Two of the common approaches to implement memcpy are driven from small code size vs. maximum throughput. The former generally uses REP MOVSD+B (see Section 3.7.5), while the latter uses SIMD instruction sets and has to deal with additional data alignment restrictions.

For processors supporting enhanced REP MOVSB/STOSB, implementing memcpy with REP MOVSB will provide even more compact benefits in code size and better throughput than using the combination of REP MOVSD+B. For processors based on Ivy Bridge microarchitecture, implementing memcpy using Enhanced REP MOVSB and STOSB might not reach the same level of throughput as using 256-bit or 128-bit AVX alternatives, depending on length and alignment factors.

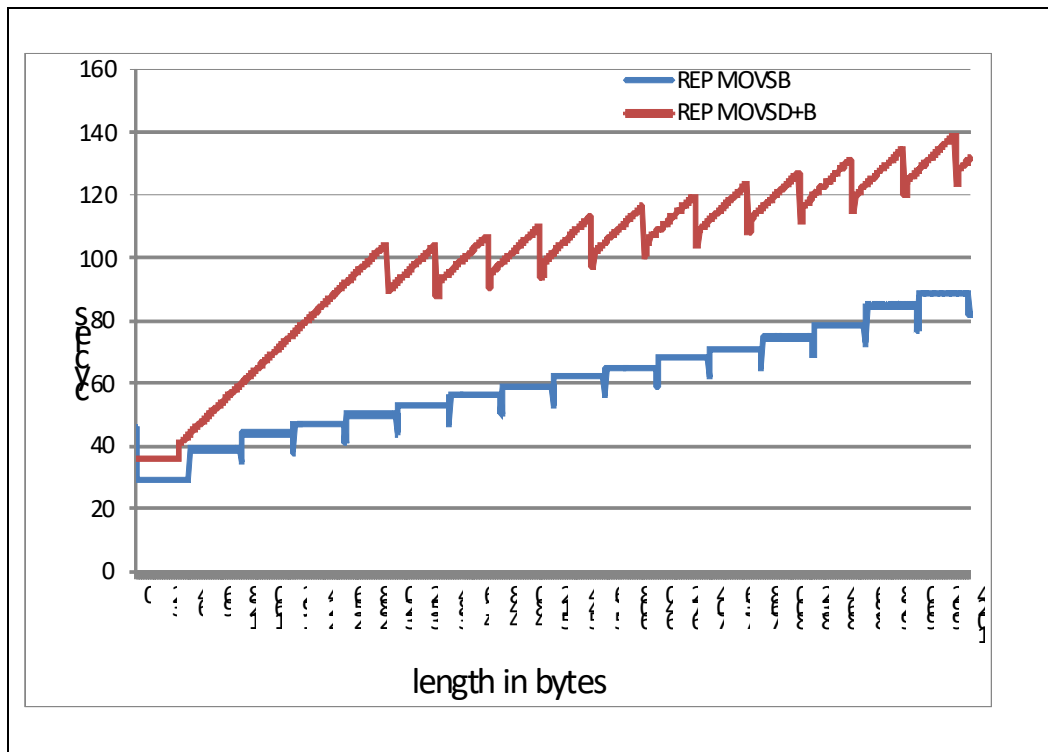

Figure 3-2. Memcpy Performance Comparison for Lengths up to 2KB

Figure 3-2 depicts the relative performance of memcopy implementation on a third-generation Intel Core processor using Enhanced REP MOVSB and STOSB versus REP MOVSD+B, for alignment conditions when both the source and destination addresses are aligned to a 16-Byte boundary and the source region does not overlap with the destination region. Using Enhanced REP MOVSB and STOSB always delivers better performance than using REP MOVSD+B. If the length is a multiple of 64, it can produce even higher performance. For example, copying 65-128 bytes takes 40 cycles, while copying 128 bytes needs only 35 cycles.

If an application wishes to bypass standard memcopy library implementation with its own custom implementation and have freedom to manage the buffer length allocation for both source and destination, it may be worthwhile to manipulate the lengths of its memory copy operation to be multiples of 64 to take advantage the code size and performance benefit of Enhanced REP MOVSB and STOSB.

The performance characteristic of implementing a general-purpose memcopy library function using a SIMD register is significantly more colorful than an equivalent implementation using a general-purpose register, depending on length, instruction set selection between SSE2, 128-bit AVX, 256-bit AVX, relative alignment of source/destination, and memory address alignment granularities/boundaries, etc.

Hence comparing performance characteristics between a memcopy using Enhanced REP MOVSB and STOSB versus a SIMD implementation is highly dependent on the particular SIMD implementation. The remainder of this section discusses the relative performance of memcopy using Enhanced REP MOVSB and STOSB versus unpublished, optimized 128-bit AVX implementation of memcopy to illustrate the hardware capability of Ivy Bridge microarchitecture.

Table 3-5. Relative Performance of Memcpy() Using Enhanced REP MOVSB and STOSB Vs. 128-bit AVX

Range of Lengths (bytes)	<128	128 to 2048	2048 to 4096
Memcpy_ERMSB/Memcpy_AVX128	0x7X	1X	1.02X

Table 3-5 shows the relative performance of the Memcpy function implemented using enhanced REP MOVSB versus 128-bit AVX for several ranges of memcpy lengths, when both the source and destination addresses are 16-byte aligned and the source region and destination region do not overlap. For memcpy length less than 128 bytes, using Enhanced REP MOVSB and STOSB is slower than what's possible using 128-bit AVX, due to internal start-up overhead in the REP string.

For situations with address misalignment, memcpy performance will generally be reduced relative to the 16-byte alignment scenario (see Table 3-6).

Table 3-6. Effect of Address Misalignment on Mемcpy() Performance

Address Misalignment	Performance Impact
Source Buffer	The impact on Enhanced REP MOVSB and STOSB implementation versus 128-bit AVX is similar.
Destination Buffer	The impact on Enhanced REP MOVSB and STOSB implementation can be 25% degradation, while 128-bit AVX implementation of memcpy may degrade only 5%, relative to 16-byte aligned scenario.

Memcpy() implemented with Enhanced REP MOVSB and STOSB can benefit further from the 256-bit SIMD integer data-path in Haswell microarchitecture. See Section 15.16.3.

3.7.6.3 Memmove Considerations

When there is an overlap between the source and destination regions, software may need to use memmove instead of memcpy to ensure correctness. It is possible to use REP MOVSB in conjunction with the direction flag (DF) in a memmove() implementation to handle situations where the latter part of the source region overlaps with the beginning of the destination region. However, setting the DF to force REP MOVSB to copy bytes from high towards low addresses will experience significant performance degradation.

When using Enhanced REP MOVSB and STOSB to implement memmove function, one can detect the above situation and handle first the rear chunks in the source region that will be written to as part of the destination region, using REP MOVSB with the DF=0, to the non-overlapping region of the destination. After the overlapping chunks in the rear section are copied, the rest of the source region can be processed normally, also with DF=0.

3.7.6.4 Memset Considerations

The consideration of code size and throughput also applies for memset() implementations. For processors supporting Enhanced REP MOVSB and STOSB, using REP STOSB will again deliver more compact code size and significantly better performance than the combination of STOSD+B technique described in Section 3.7.5.

When the destination buffer is 16-byte aligned, memset() using Enhanced REP MOVSB and STOSB can perform better than SIMD approaches. When the destination buffer is misaligned, memset() performance using Enhanced REP MOVSB and STOSB can degrade about 20% relative to aligned case, for processors based on Ivy Bridge microarchitecture. In contrast, SIMD implementation of memset() will experience smaller degradation when the destination is misaligned.

Memset() implemented with Enhanced REP MOVSB and STOSB can benefit further from the 256-bit data path in Haswell microarchitecture. see Section 15.16.3.3.

3.8 REP STRING OPERATIONS

Several REP string performance enhancements are available beginning with processors based on Golden Cove microarchitecture.

3.8.1 Fast Zero Length REP MOVSB

REP MOVSB performance of zero length operations is enhanced. The latency of a zero length REP MOVSB is now the same as the latency of lengths 1 to 128 bytes. When both Fast Short REP MOVSB and Fast Zero Length REP MOVSB features are enabled, REP MOVSB performance is flat 9 cycles per operation, for all strings 0-128 byte long whose source and destination operands reside in the processor first level cache.

Support for fast zero-length REP MOVSB is enumerated by the CPUID feature flag:

CPUID.07H.01H:EAX.FAST_ZERO_LENGTH_REP_MOVSB[bit 10] = 1.

3.8.2 Fast Short REP STOSB

REP STOSB performance of short operations is enhanced. The enhancement applies to string lengths between 0 and 128 bytes long. When Fast Short REP STOSB feature is enabled, REP STOSB performance is flat 12 cycles per operation, for all strings 0-128 byte long whose destination operand resides in the processor first level cache.

Support for fast-short REP STOSB is enumerated by the CPUID feature flag:

CPUID.07H.01H:EAX.FAST_SHORT_REP_STOSB[bit 11] = 1.

3.8.3 Fast Short REP CMPSB and SCASB

REP CMPSB and SCASB performance is enhanced. The enhancement applies to string lengths between 1 and 128 bytes long. When the Fast Short REP CMPSB and SCASB feature is enabled, REP CMPSB and REP SCASB performance is flat 15 cycles per operation, for all strings 1-128 byte long whose two source operands reside in the processor first level cache.

Support for fast short REP CMPSB and SCASB is enumerated by the CPUID feature flag:

CPUID.07H.01H:EAX.FAST_SHORT_REP_CMPSB_SCASB[bit 12] = 1.

3.9 FLOATING-POINT CONSIDERATIONS

When programming floating-point applications, it is best to start with a high-level programming language such as C, C++, or Fortran. Many compilers perform floating-point scheduling and optimization when it is possible. However in order to produce optimal code, the compiler may need some assistance.

3.9.1 Guidelines for Optimizing Floating-point Code

User/Source Coding Rule 9. (M impact, M generality) Enable the compiler's use of SSE, SSE2, AVX, AVX2, and possibly more advanced SIMD instruction sets (AVX-512) with appropriate switches. Favor scalar SIMD code generation to replace x87 code generation.

Follow this procedure to investigate the performance of your floating-point application:

- Understand how the compiler handles floating-point code.
- Look at the assembly dump and see what transforms are already performed on the program.
- Study the loop nests in the application that dominate the execution time.
- Determine why the compiler is not creating the fastest code.
- See if there is a dependence that can be resolved.
- Determine the problem area: bus bandwidth, cache locality, trace cache bandwidth, or instruction latency. Focus on optimizing the problem area. For example, adding PREFETCH instructions will not help if the bus is already saturated. If trace cache bandwidth is the problem, added prefetch `µops` may degrade performance.

Also, in general, follow the general coding recommendations discussed in this chapter, including:

- Blocking the cache.
- Using prefetch.
- Enabling vectorization.
- Unrolling loops.

User/Source Coding Rule 10. (H impact, ML generality) *Make sure your application stays in range to avoid denormal values, underflows.*

Out-of-range numbers cause very high overhead.

When converting floating-point values to 16-bit, 32-bit, or 64-bit integers using truncation, the instructions CVTTSS2SI and CVTTSD2SI are recommended over instructions that access x87 FPU stack. This avoids changing the rounding mode.

User/Source Coding Rule 11. (M impact, ML generality) *Usually, math libraries take advantage of the transcendental instructions (for example, FSIN) when evaluating elementary functions. If there is no critical need to evaluate the transcendental functions using the extended precision of 80 bits, applications should consider an alternate, software-based approach, such as a look-up-table-based algorithm using interpolation techniques. It is possible to improve transcendental performance with these techniques by choosing the desired numeric precision and the size of the look-up table, and by taking advantage of the parallelism of the SSE and the SSE2 instructions.*

3.9.2 Floating-point Modes and Exceptions

When working with floating-point numbers, high-speed microprocessors frequently must deal with situations that need special handling in hardware or code.

3.9.2.1 Floating-point Exceptions

The most frequent cause of performance degradation is the use of masked floating-point exception conditions such as:

- Arithmetic overflow.
- Arithmetic underflow.
- Denormalized operand.

Refer to Chapter 4 of *Intel® 64 and IA-32 Architectures Software Developer's Manual, Volume 1* for definitions of overflow, underflow and denormal exceptions.

Denormalized floating-point numbers impact performance in two ways:

- Directly when are used as operands.
- Indirectly when are produced as a result of an underflow situation.

If a floating-point application never underflows, the denormals can only come from floating-point constants.

User/Source Coding Rule 12. (H impact, ML generality) *Denormalized floating-point constants should be avoided as much as possible.*

Denormal and arithmetic underflow exceptions can occur during the execution of x87 instructions or SSE/SSE2/SSE3 instructions. Processors based on Intel NetBurst microarchitecture handle these exceptions more efficiently when executing SSE/SSE2/SSE3 instructions and when speed is more important than complying with the IEEE standard. The following paragraphs give recommendations on how to optimize your code to reduce performance degradations related to floating-point exceptions.

3.9.2.2 Dealing with floating-point exceptions in x87 FPU code

Every special situation listed in Section 3.9.2.1, “Floating-point Exceptions,” is costly in terms of performance. For that reason, x87 FPU code should be written to avoid these situations.

There are basically three ways to reduce the impact of overflow/underflow situations with x87 FPU code:

- Choose floating-point data types that are large enough to accommodate results without generating arithmetic overflow and underflow exceptions.
- Scale the range of operands/results to reduce as much as possible the number of arithmetic overflow/underflow situations.
- Keep intermediate results on the x87 FPU register stack until the final results have been computed and stored in memory. Overflow or underflow is less likely to happen when intermediate results are kept in the x87 FPU stack (this is because data on the stack is stored in double extended-precision format and overflow/underflow conditions are detected accordingly).
- Denormalized floating-point constants (which are read-only, and hence never change) should be avoided and replaced, if possible, with zeros of the same sign.

3.9.2.3 Floating-point Exceptions in SSE/SSE2/SSE3 Code

Most special situations that involve masked floating-point exceptions are handled efficiently in hardware. When a masked overflow exception occurs while executing SSE/SSE2/SSE3/AVX/AVX2/AVX-512 code, processor hardware can handle it without performance penalty.

Underflow exceptions and denormalized source operands are usually treated according to the IEEE 754 specification, but this can incur significant performance delay. If a programmer is willing to trade pure IEEE 754 compliance for speed, two non-IEEE 754 compliant modes are provided to speed situations where underflows and input are frequent: FTZ mode and DAZ mode.

When the FTZ mode is enabled, an underflow result is automatically converted to a zero with the correct sign. Although this behavior is not compliant with IEEE 754, it is provided for use in applications where performance is more important than IEEE 754 compliance. Since denormal results are not produced when the FTZ mode is enabled, the only denormal floating-point numbers that can be encountered in FTZ mode are the ones specified as constants (read only).

The DAZ mode is provided to handle denormal source operands efficiently when running a SIMD floating-point application. When the DAZ mode is enabled, input denormals are treated as zeros with the same sign. Enabling the DAZ mode is the way to deal with denormal floating-point constants when performance is the objective.

If departing from the IEEE 754 specification is acceptable and performance is critical, run SSE/SSE2/SSE3/AVX/AVX2/AVX-512 applications with FTZ and DAZ modes enabled.

NOTE

The DAZ mode is available with both the SSE and SSE2 extensions, although the speed improvement expected from this mode is fully realized only in SSE code and later.

3.9.3 Floating-point Modes

For x87 code, using the FLDCW instruction to change floating modes can be an expensive operation in many cases.

Recent processor generations provide hardware optimization for FLDCW that allows programmers to alternate between two constant values efficiently. For the FLDCW optimization to be effective, the two constant FCW values are only allowed to differ on the following 5 bits in the FCW:

```
FCW[8-9]    ; Precision control
FCW[10-11]  ; Rounding control
FCW[12]     ; Infinity control
```

If programmers need to modify other bits (for example: mask bits) in the FCW, the FLDCW instruction is still an expensive operation.

In situations where an application cycles between three (or more) constant values, FLDCW optimization does not apply, and the performance degradation occurs for each FLDCW instruction.

One solution to this problem is to choose two constant FCW values, take advantage of the optimization of the FLDCW instruction to alternate between only these two constant FCW values, and devise some means to accomplish the task that requires the 3rd FCW value without actually changing the FCW to a third constant value. An alternative solution is to structure the code so that, for periods of time, the application alternates between only two constant FCW values. When the application later alternates between a pair of different FCW values, the performance degradation occurs only during the transition.

It is expected that SIMD applications are unlikely to alternate between FTZ and DAZ mode values. Consequently, the SIMD control word does not have the short latencies that the floating-point control register does. A read of the MXCSR register has a fairly long latency, and a write to the register is a serializing instruction.

There is no separate control word for single and double precision; both use the same modes. Notably, this applies to both FTZ and DAZ modes.

Assembly/Compiler Coding Rule 52. (H impact, M generality) *Minimize changes to bits 8-12 of the floating-point control word. Changes for more than two values (each value being a combination of the following bits: precision, rounding and infinity control, and the rest of bits in FCW) leads to delays that are on the order of the pipeline depth.*

3.9.3.1 Rounding Mode

Many libraries provide float-to-integer library routines that convert floating-point values to integer. Many of these libraries conform to ANSI C coding standards which state that the rounding mode should be truncation. With the Pentium 4 processor, one can use the CVTTSD2SI and CVTTSS2SI instructions to convert operands with truncation without ever needing to change rounding modes. The cost savings of using these instructions over the methods below is enough to justify using SSE and SSE2 wherever possible when truncation is involved.

For x87 floating-point, the FIST instruction uses the rounding mode represented in the floating-point control word (FCW). The rounding mode is generally “round to nearest”, so many compiler writers implement a change in the rounding mode in the processor in order to conform to the C and FORTRAN standards. This implementation requires changing the control word on the processor using the FLDCW instruction. For a change in the rounding, precision, and infinity bits, use the FSTCW instruction to store the floating-point control word. Then use the FLDCW instruction to change the rounding mode to truncation.

In a typical code sequence that changes the rounding mode in the FCW, a FSTCW instruction is usually followed by a load operation. The load operation from memory should be a 16-bit operand to prevent store-forwarding problem. If the load operation on the previously-stored FCW word involves either an 8-bit or a 32-bit operand, this will cause a store-forwarding problem due to mismatch of the size of the data between the store operation and the load operation.

To avoid store-forwarding problems, make sure that the write and read to the FCW are both 16-bit operations.

If there is more than one change to the rounding, precision, and infinity bits, and the rounding mode is not important to the result, use the algorithm in Example 3-54 to avoid synchronization issues, the overhead of the FLDCW instruction, and having to change the rounding mode. Note that the example suffers

from a store-forwarding problem which will lead to a performance penalty. However, its performance is still better than changing the rounding, precision, and infinity bits among more than two values.

Example 3-54. Algorithm to Avoid Changing Rounding Mode

```

_fto132proc
  lea   ecx, [esp-8]
  sub   esp, 16      ; Allocate frame
  and   ecx, -8      ; Align pointer on boundary of 8
  fld   st(0)        ; Duplicate FPU stack top

  fistp qword ptr[ecx]
  fild  qword ptr[ecx]
  mov   edx, [ecx+4] ; High DWORD of integer
  mov   eax, [ecx]   ; Low DWIRD of integer
  test  eax, eax
  je    integer_QnaN_or_zero

arg_is_not_integer_QnaN:
  fsubp st(1), st    ; TOS=d-round(d), { st(1) = st(1)-st & pop ST}
  test  edx, edx     ; What's sign of integer
  jns   positive     ; Number is negative
  fstp  dword ptr[ecx] ; Result of subtraction
  mov   ecx, [ecx]   ; DWORD of diff(single-precision)
  add   esp, 16
  xor   ecx, 80000000h
  add   ecx, 7fffffffh ; If diff<0 then decrement integer
  adc   eax, 0        ; INC EAX (add CARRY flag)
  ret

positive:
  positive:
  fstp  dword ptr[ecx] ; 17-18 result of subtraction
  mov   ecx, [ecx]     ; DWORD of diff(single precision)
  add   esp, 16
  add   ecx, 7fffffffh ; If diff<0 then decrement integer
  sbb  eax, 0          ; DEC EAX (subtract CARRY flag)
  ret

integer_QnaN_or_zero:
  test  edx, 7fffffffh
  jnz  arg_is_not_integer_QnaN
  add  esp, 16
  ret

```

Assembly/Compiler Coding Rule 53. (H impact, L generality) Minimize the number of changes to the rounding mode. Do not use changes in the rounding mode to implement the floor and ceiling functions if this involves a total of more than two values of the set of rounding, precision, and infinity bits.

3.9.3.2 Precision

If single precision is adequate, use it instead of double precision. This is true because:

- Single precision operations allow the use of longer SIMD vectors, since more single precision data elements can fit in a register.
- If the precision control (PC) field in the x87 FPU control word is set to single precision, the floating-point divider can complete a single-precision computation much faster than either a double-precision

computation or an extended double-precision computation. If the PC field is set to double precision, this will enable those x87 FPU operations on double-precision data to complete faster than extended double-precision computation. These characteristics affect computations including floating-point divide and square root.

Assembly/Compiler Coding Rule 54. (H impact, L generality) *Minimize the number of changes to the precision mode.*

3.9.4 x87 vs. Scalar SIMD Floating-point Trade-offs

There are a number of differences between x87 floating-point code and scalar floating-point code (using SSE and SSE2). The following differences should drive decisions about which registers and instructions to use:

- When an input operand for a SIMD floating-point instruction contains values that are less than the representable range of the data type, a denormal exception occurs. This causes a significant performance penalty. An SIMD floating-point operation has a flush-to-zero mode in which the results will not underflow. Therefore subsequent computation will not face the performance penalty of handling denormal input operands. For example, in the case of 3D applications with low lighting levels, using flush-to-zero mode can improve performance by as much as 50% for applications with large numbers of underflows.
- Scalar floating-point SIMD instructions have lower latencies than equivalent x87 instructions. Scalar SIMD floating-point multiply instruction may be pipelined, while x87 multiply instruction is not.
- Although x87 supports transcendental instructions, software library implementation of transcendental function can be faster in many cases.
- x87 supports 80-bit precision, double extended floating-point. SSE support a maximum of 32-bit precision. SSE2 supports a maximum of 64-bit precision.
- Scalar floating-point registers may be accessed directly, avoiding FXCH and top-of-stack restrictions.
- The cost of converting from floating-point to integer with truncation is significantly lower with Streaming SIMD Extensions 2 and Streaming SIMD Extensions in the processors based on Intel NetBurst microarchitecture than with either changes to the rounding mode or the sequence prescribed in the Example 3-54.

Assembly/Compiler Coding Rule 55. (M impact, M generality) *Use Streaming SIMD Extensions 2 or Streaming SIMD Extensions unless you need an x87 feature. Most SSE2 arithmetic operations have shorter latency than their X87 counterpart and they eliminate the overhead associated with the management of the X87 register stack.*

3.9.4.1 Scalar SSE/SSE2

In code sequences that have conversions from floating-point to integer, divide single-precision instructions, or any precision change, x87 code generation from a compiler typically writes data to memory in single-precision and reads it again in order to reduce precision. Using SSE/SSE2 scalar code instead of x87 code can generate a large performance benefit using Intel NetBurst microarchitecture and a modest benefit on Intel Core Solo and Intel Core Duo processors.

Recommendation: Use the compiler switch to generate scalar floating-point code using XMM rather than x87 code.

When working with scalar SSE/SSE2 code, pay attention to the need for clearing the content of unused slots in an XMM register and the associated performance impact. For example, loading data from memory with MOVSS or MOVSD causes an extra micro-op for zeroing the upper part of the XMM register.

3.9.4.2 Transcendental Functions

If an application needs to emulate math functions in software for performance or other reasons (see Section 3.9.1, "Guidelines for Optimizing Floating-point Code"), it may be worthwhile to inline math

library calls because the CALL and the prologue/epilogue involved with such calls can significantly affect the latency of operations.

3.10 MAXIMIZING PCIE PERFORMANCE

PCIe performance can be dramatically impacted by the size and alignment of upstream reads and writes (read and write transactions issued from a PCIe agent to the host's memory). As a general rule, the best performance, in terms of both bandwidth and latency, is obtained by aligning the start addresses of upstream reads and writes on 64-byte boundaries and ensuring that the request size is a multiple of 64-bytes, with modest further increases in bandwidth when larger multiples (128, 192, 256 bytes) are employed. In particular, a partial write will cause a delay for the following request (read or write).

A second rule is to avoid multiple concurrently outstanding accesses to a single cache line. This can result in a conflict which in turn can cause serialization of accesses that would otherwise be pipelined, resulting in higher latency and/or lower bandwidth. Patterns that violate this rule include sequential accesses (reads or writes) that are not a multiple of 64-bytes, as well as explicit accesses to the same cache line address. Overlapping requests—those with different start addresses but with request lengths that result in overlap of the requests—can have the same effect. For example, a 96-byte read of address 0x00000200 followed by a 64-byte read of address 0x00000240 will cause a conflict—and a likely delay—for the second read.

Upstream writes that are a multiple of 64-byte but are non-aligned will have the performance of a series of partial and full sequential writes. For example, a write of length 128-byte to address 0x00000070 will perform similarly to 3 sequential writes of lengths 16, 64, and 48 to addresses 0x00000070, 0x00000080, and 0x00000100, respectively.

For PCIe cards implementing multi-function devices, such as dual or quad port network interface cards (NICs) or dual-GPU graphics cards, it is important to note that non-optimal behavior by one of those devices can impact the bandwidth and/or latency observed by the other devices on that card. With respect to the behavior described in this section, all traffic on a given PCIe port is treated as if it originated from a single device and function.

For the best PCIe bandwidth:

1. Align start addresses of upstream reads and writes on 64-byte boundaries.
2. Use read and write requests that are a multiple of 64-bytes.
3. Eliminate or avoid sequential and random partial line upstream writes.
4. Eliminate or avoid conflicting upstream reads, including sequential partial line reads.

Techniques for avoiding performance pitfalls include cache line aligning all descriptors and data buffers, padding descriptors that are written upstream to 64-byte alignment, buffering incoming data to achieve larger upstream write payloads, allocating data structures intended for sequential reading by the PCIe device in such a way as to enable use of (multiple of) 64-byte reads. The negative impact of unoptimized reads and writes depends on the specific workload and the microarchitecture on which the product is based.

3.10.1 Optimizing PCIe Performance for Accesses Toward Coherent Memory and Toward MMIO Regions (P2P)

In order to maximize performance for PCIe devices in the processors listed in Table 3-7 below, the software should determine whether the accesses are toward coherent memory (system memory) or toward MMIO regions (P2P access to other devices). If the access is toward MMIO region, then software can command HW to set the RO bit in the TLP header, as this would allow hardware to achieve maximum throughput for these types of accesses. For accesses toward coherent memory, software can command

HW to clear the RO bit in the TLP header (no RO), as this would allow hardware to achieve maximum throughput for these types of accesses.

Table 3-7. Intel Processor CPU RP Device IDs for Processors Optimizing PCIe Performance

Processor	CPU RP Device IDs
Intel Xeon processors based on Broadwell microarchitecture	6F01H-6F0EH
Intel Xeon processors based on Haswell microarchitecture	2F01H-2F0EH

3.11 SCALABILITY WITH CONTENTED LINE ACCESS IN INTEL® 4TH GENERATION INTEL® XEON® SCALABLE PROCESSORS

A two-socket Sapphire Rapids system can have up to 224 (2 sockets x 56 cores/socket x 2 threads/core) hardware threads. Scalability and performance bottlenecks may happen when all of these hardware threads compete for the same address.

3.11.1 Why it Happens

When multiple hardware threads go after the same address (say AA), this address is queued in the Ingress Queue, with one entry for each hardware thread. Due to the resource limitation of the Ingress Queue, the CPU core is throttled to slow the rate of requests when this queue overflows. This usually occurs with contention for a lock.

3.11.2 How to Detect it

When multiple cores are contending on the same lock, several outstanding requests are mapped to that same address. The `Phys_addr_match` event can count as such an event. This CHA event increments by one every other cycle when there is more than one outstanding request to the same address.

Here are the PMU event id and Umask for the 2 CHA events that are very useful for detecting contention

1. `Phys_addr_match` event: Event id: 0x19, Umask: 0x80
2. `CHA_clockticks` event: Event id: 0x01, Umask: 0x01

These events have to be measured on a per-CHA basis, and if the ratio of the counts between `phys_addr_match` to `CHA_clockticks` is more than 0.15 on any CHA that indicates > 30% of the CHA cycles (2x the ratio as this event can count only once every two cycles) are spent with multiple requests outstanding to the same address.

Here is the recipe to measure these events with Linux Perf:

```
$ sudo perf stat -a -e 'uncore_cha/event=0x19,umask=0x80,uncore_cha/event=0x1,umask=0x1' --per-socket --no-merge -- sleep 30
```

Once it is confirmed that the ratio of `phys_addr_match` events to the CHA clockticks is more than 0.15, the next step would be to figure out where this may be happening in the code. Intel CPUs provide a PMU mechanism wherein a load operation is randomly selected and tracked through completion and the actual latency is recorded if it is over a given threshold. The threshold value is specified in cycles and must be in the power of 2. In the “perf mem record” command below, we are defining a command to sample all loads that take more than 128 cycles to complete.

```
$ sudo perf mem record -a --ldlat 128 sleep 1
```

Once the above data is collected, execute the following command to process the data collected

```
$ sudo perf mem report.
```

Information similar to the table below will be generated. This has details on hot loads along with data linear address and the actual latency that the load experienced. This can be used to identify the necessary fixes to the code.

Table 3-8. Samples: 365K of events 'anon group[cpu/mem-loads-aux/,cpu/mem-loads,ldat=128/pp]', Event count (a--r0x): 67900852

Overhead	Sam ples	Local weight	Mem. acces s	Symbol	Shared Object	Data Symb ol	Dat a Obj ect	Snoop	TLB Acces s	Lock ed	Blocke d	Local INSTR Latenc y
0.22% 0.07%	1	1 38060	L3 or L3 hit	[.]asm_m utex	lockcon tention	[.]0x0 00055 6db14 282a0	[he ap]	HitM	L1 or L2 hit	Yes	N/A	47251
0.18% 0.06%	1	1 31338	L3 or L3 hit	[.]asm_m utex	lockcon tention	[.]0x0 00055 6db14 282a0	[he ap]	HitM	L1 or L2 hit	Yes	N/A	40411
0.17% 0.06%	1	1 29572	L3 or L3 hit	[.]asm_m utex	lockcon tention	[.]0x0 00055 6db14 282a0	[he ap]	HitM	L1 or L2 hit	Yes	N/A	36652

3.11.3 How to Fix it

The following is a list of suggested solutions:

1. Run multiple instances of the workload with a scale-out approach instead of a single instance with scale-up so that the contention for per instance hot variables (including locks) is reduced.
2. Guard the cmpxchg by checking that the destination memory is expected with a load, test, and branch beforehand
3. Implement a backoff mechanism so that the cmpxchg is issued less. For example, in locks, exponential backoff is a common and effective method to prevent all cores from being in lockstep. In the case of contention for a lock, checking to see if it is accessible by a load before trying to write to it through a cmpxchg will help. Below is an example pseudo-code:

Example 3-55. Locking Algorithm for Sapphire Rapids

```
lock_loop:
while (lock is not free) // just a load operation
    execute pause;

// now the lock is free. So, try to acquire it.
Exponential Backoff spin // so all the cores don't come back at the same time
Execute cmpxchg on the lock
if the lock is not successfully acquired, goto lock_loop
```

Additionally, as the core counts continue to increase, exploring other algorithmic fixes that dissolve or reduce contention on memory variables (including locks) is essential. For example, instead of frequently updating a hot statistical variable from all threads, consider updating a copy of it per thread (without contention) and later aggregate the updated per-thread copies on a less frequent basis or use some existing atomic-free concurrency methods such as rseq¹. As another example, restructure locking algorithms to use hierarchical locking when excessive contention is detected on a global lock.

3.11.4 Case Study: SysBench/MariaDB Metric CHA % Cycles Fast Asserted

With SysBench/MariaDB 10.3.34, the workload's throughput drops as the number of threads increases. Another metric we can use is the CHA% Cycles Fast Asserted. It is a signal to slow down the cores when the Ingress Queue fills up. This is another way to identify scalability issues. The graph below plots the number of active client threads representing the work intensity on the horizontal axis. The percentage of Fast Asserts is plotted on the vertical axis.

The baseline case (blue line) had a sharp throughput with increased thread count, as all cores reduced their throughput as they suffered from the increasing percent of Fast Asserts. With the same work distributed instances (red line), Fast asserts dropped. Similarly, with a software fix (gray line), again, the Fast Asserts dropped even though only one instance was in execution.

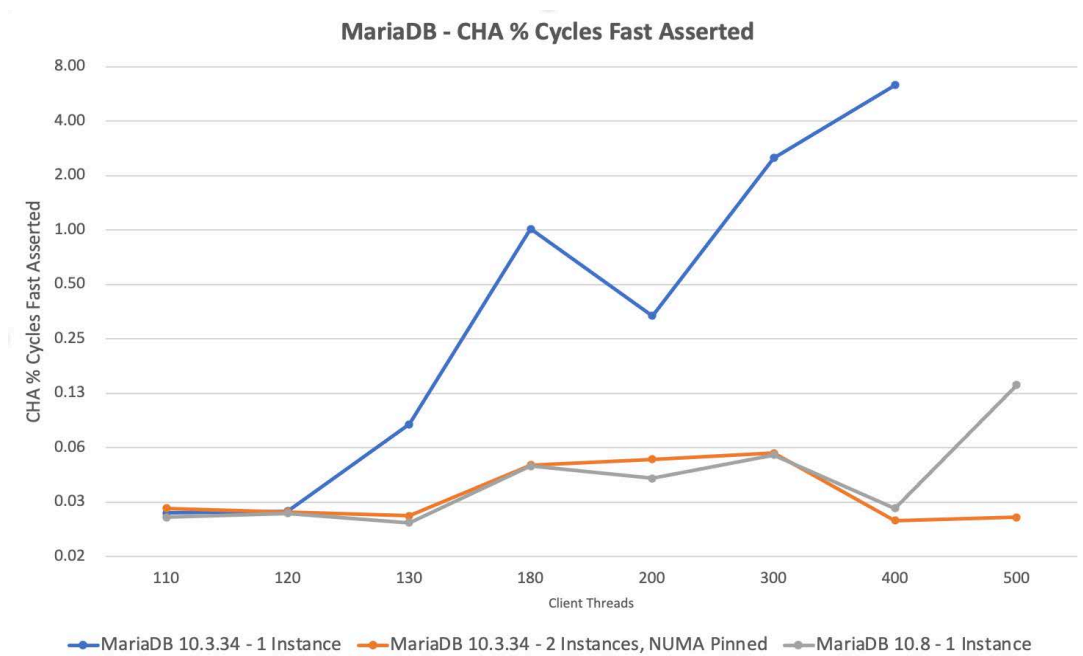

Figure 3-3. MariaDB - CHA % Cycles Fast Asserted

1. <https://git.kernel.org/pub/scm/libs/librseq/librseq.git/tree/doc/man/rseq.2>

3.11.5 Instruction Sequence Slowdowns

The Golden Cove CPU microarchitecture upon which Sapphire Rapids is based has increased the cost of mixing Legacy SSE and VEX without clearing the state of upper registers for power efficiency reasons.

3.11.5.1 Why it Happens

The Golden Cove CPU microarchitecture eliminated some hardware speed paths for power efficiency and replaced them with microcode. The following instruction sequence mixes VEX and Legacy SSE, for example, has higher Core Cycles than on the previous generation Sunny Cove CPU microarchitecture for the Ice Lake version of Xeon 3 (ICX). It is due to more micro-ops being executed.

Table 3-9. Instruction Sequence Mixing VEX and Legacy on Sapphire Rapids and ICX

Intel Syntax for Assembly Code	Ice lake (Sunny Cove)		Sapphire Rapids (Golden Cove)	
	Inst Retired	Core Cycles	Inst Retired	Core Cycles
VPXOR XMM3, XMM3, XMM3; VEXTRACTI128 XMM3, YMM3, 1; PXOR XMM3, XMM3	3.00	1	3.00	388.04

3.11.5.2 How to Detect it

The event `ASSISTS.SSE_AVX_MIX` can be used to determine if there are VEX to legacy SSE transitions. The following Linux perf command-line can be used while the workload is running:

```
$ sudo perf stat -e 'assists.sse_avx_mix'1 <workload>
```

With the Intel TMA (Topdown Methodology) (there is a metric called `Mixing_Vectors` which gives the percentage of injected blend uops out of all the uops issued. Usually, a `Mixing_Vectors` metric over 5% is worth investigating. You can find more details in Appendix B1 of the Optimizations Guide.

3.11.5.3 How to Fix it

The following is a list of suggested solutions:

1. When possible, use VEX-encoded instructions for all the SIMD instructions when possible.
2. Insert a `VZERoupper` to tell the hardware that the state of the higher registers is clean between the VEX and the legacy SSE instructions. Often the best way to do this is to insert a `VZERoupper` before returning from any function that uses VEX (that does not produce a VEX register) and before any call to an unknown function.

1. Using upstream perf. If OS doesn't have support for the event use `cpu/event=0xc1,umask=0x10,name=assists_sse_avx_mix/`

VZEROUPPER was inserted in the code sequence below and there are no SSE_AVX_MIX assists. With this change, the Core Cycles do not have a performance inversion relative to the previous generation.

Example 3-56. Fixed Instruction Sequence with Improved Performance on Sapphire Rapids

Intel Syntax for Assembly Code	Ice Lake (Sunny Cove)		Sapphire Rapids (Golden Cove)		ASSISTS.SSE_AVX_MIX
	Inst Retired	Core Cycles	Inst Retired	Core Cycles	
VPXOR XMM3, XMM3, XMM3; VEXTRACT1128 XMM3, YMM3, 1; VZEROUPPER; PXOR XMM3, XMM3	4.00	2.00	4.00	1.00	0

3.11.6 Misprediction for Branches >2GB

The Golden Cove CPU is a wider machine and might exhibit a higher Top-down Microarchitecture Analysis (TMA) Bad Speculation percentage. Please see B.1.1 for additional information about TMA. Some sources of Bad Speculation are branch prediction misses. In this case, however, Bad Speculation is due to the wider machine and less efficient branch prediction for certain indirect branches.

3.11.6.1 Why it Happens

For a near absolute indirect JMP/CALL branch instruction (opcodes FF /4 and FF /2), the branch distance (ADDR_TARGET - ADDR_BRANCH) affects the performance of the branch predictor as follows. The branch predictor uses fewer resources to predict the branch if its distance can be specified with a 32-bit signed displacement (JMP/CALL imm32). If the distance is larger (>2GB), the predictor uses more resources to predict the branch, and performance may suffer.

3.11.6.2 How to Detect it

You can use the Intel LBR to identify jumps greater than 2GB. The collection of performance analysis tools based on perf on Linux supports this. The following is an example output from the tool. It shows that 21% of the call/jumps of >2GB offset are mispredicted. The histogram of one of the indirect branches at address 0x555555603664 shows that it is to one target and in a library. The profile mask is to use LBR, and the duration is 10 seconds. It does a system-level profile.

```
% ./do.py profile --profile-mask=0x100 -s 10

count of indirect call/jump of >2GB offset: 93200
count of mispredicted indirect call/jump of >2GB offset: 19943
misprediction ratio for indirect branch at address 0x7ffff577eca4: 4.23%
misprediction ratio for indirect branch at address 0x5555556030c4: 32.23%
misprediction ratio for indirect branch at address 0x555555603664: 22.30%
misprediction ratio for indirect branch at address 0x555555603c24: 13.84%
...
indirect_0x555555603664 histogram:
0x7ffff7af2670: 50501 100.0%
```

Figure 3-4. Identifying >2GB Branches

3.11.6.3 How to Fix it

Arrange the code so the jumps don't span the >2GB range. This can be done through a variety of approaches:

1. If possible, statically link all the libraries into the executable.
2. For **.text** to library code, use the Glibc environment variable `LD_PREFER_MAP_32BIT_EXEC=1` to restrict the addresses into the 4GB range.
3. For dynamically compiled code, keep it close to the `.text` address or copy the frequently called entries into the dynamically compiled code address region. See the Google v8 Blog.

In a case study with WordPress/PHP running eight containers with and without the 2GB fix, the CPI and performance scores improve by 6%.

Example 3-57. WordPress/PHP Case Study: with and without 2GB Fix for Branch Misprediction

		WP4.2 / PHP7.4.29 - NO FIX	WP4.2 / PHP7.4.29 - 2G FIX in Glibc	2G FIX/ NO FIX
	Workers	8c x 42	8c x 42	
Config	Cores Per socket	56	56	1.00
	Sockets	2	2	1.00
	Total Cores	112	112	1.00
	Total Thread Count	224	224	1.00
Performance	Throughput	1.0	1.06	1.06
	CPI	1.12	1.05	0.96
Path Length	Instructions per Unit of Work	33,789,862.68	33,730,155.10	1.00
Cycles per Transaction	Cycles per Unit of Work	37,803,310.48	35,359,628.33	0.94

3.12 OPTIMIZING COMMUNICATION WITH PCI DEVICES ON INTEL® 4TH GENERATION INTEL® XEON® SCALABLE PROCESSORS

The Sapphire Rapids microarchitecture introduced a new set of instructions designed to optimize communication between SW running on IA cores and PCI devices on the platform.

3.12.1 Signaling Devices with Direct Move

Most software-to-device interaction follows a producer-to-consumer relationship where the software creates work for the device and then signals it to inform the device that work is available. Descriptor rings are the ubiquitous pattern here and once descriptors are added to the ring, the signal (or “doorbell”) consists of an update to the tail pointer register on the device. This is a write to an MMIO-mapped BAR register.

Such writes tend to be relatively expensive operations –the latency to complete the write to the device is high relative to the CPU operating speed. Since writes are ordered by default, this creates a bubble during which subsequent writes cannot be drained from store buffers. Signaling can therefore affect performance via store backpressure.

As a result, some software libraries avoid frequent signaling by batching relatively large quantities of work descriptors with each doorbell update. However, this is not always possible, and it introduces latency.

The Sapphire Rapids microarchitecture introduces “Direct Store” instructions to optimize signaling; there are two instructions in the family:

- MOVDIRI: 4/8B direct store
- MOVDIR64B: 64B atomic direct copy

Direct Stores are weakly ordered (like non-temporal or USWC-mapped memory writes) regardless of the underlying memory type (which is usually UC for MMIO-mapped locations). Since they do not order subsequent writes the performance issue described above does not occur.

Since they are intended for signaling, direct stores will never combine with other stores to the same address, such as can happen with non-temporal or USWC writes. Each write is guaranteed to occur as issued. In the case of MOVDIR64B, the full 64B will be delivered as a single write to the device. This is the only ISA that carries an architectural guarantee of >8B atomicity.

These instructions derive benefit from the fact that signaling use cases typically do not care if subsequent writes are observed before the doorbell itself – the ordering is relaxed. However, since typically the doorbell must not be observable before earlier writes (such writes are creating the work descriptors), SW should insert a store fence immediately before the direct store.

Having a fence before the direct store does not normally limit performance– except when many direct stores are issued. If there is an SFENCE before each, the fence on direct store N+1 imposes an order on direct store N, which can remove some of the benefits. If possible, the guideline is to avoid this where possible. One technique that may work if multiple doorbells to different addresses are being issued (such as for a NIC driver that is handling multiple descriptor rings) is to group the direct stores to different locations together and insert a single SFENCE before the group.

Finally, it is worth noting that the device write latency can vary widely with the address being written. This is especially true on large CPUs implemented as multiple tiles. So if SW has the luxury of choosing between multiple addresses, it is possible to envisage adaptive schemes that “match” an address to a SW thread (especially if that thread is pinned to a single core) by selecting the best performing such address during an initialization stage.

3.12.1.1 MOVDIR64B – Additional considerations

As noted above MOVDIR64B is a copy operation; it moves data from one 64B-aligned address to another. Typical usage is that the source address is a memory location, and the destination is MMIO mapped to a device, whereupon it confers the benefits described above. However, since the source data is usually written immediately before the MOVDIR64B, there are additional considerations:

- Since the source data is written to the same address that the MOVDIR64B reads, it is not necessary to fence to ensure the source data is written before the MOVDIR64B. This can mean in some scenarios, that no store fence is needed in conjunction with MOVDIR64B (if there is no other data written to memory the correct operation of the system depends on being observed before the MOVDIR64B).
- For best performance it is important to allow store forwarding of the source data.
- This means the source data should be 64B aligned and written at the same granularity that the MOVDIR64B reads. For Sapphire Rapids, this is 64B, meaning the source data should be written using 64B AVX512 instructions for best performance.

3.12.1.2 Streaming Data

Because it is weakly ordered, MOVDIR64B can also be used to stream data to a device by copying a block of memory. This is similar in behavior to mapping the destination memory locations as USWC, except:

- The destination address can remain mapped UC.
- The writes are guaranteed to arrive at the device as 64B writes, which is not guaranteed with any other method.

3.13 SYNCHRONIZATION

3.13.1 User-Level Monitor, User-Level MWAIT, and TPAUSE

New instructions for user-level monitor and MWAIT act like legacy monitor and MWAIT instructions with additional functionality identified as the timeout and ring-3 (aka user space) application support. TPAUSE is similar to legacy pause instruction but is designed to accept time interval and sleep state parameters. User-level MWAIT and TPAUSE support the same C0.1 light sleep and C0.2 deeper sleep states. These instructions are helpful in user space applications that support a busy poll, synchronization, or asynchronous IO, such as waiting for an event. A minor code modification yields power benefits along with low latency wake-up.

3.13.1.1 Checking for User-Level Monitor, MWAIT, and TPAUSE support

This section describes how to check whether a processor supports user-level monitor, user-level MWAIT, or TPAUSE; if user-level monitor, user-level MWAIT, or TPAUSE instruction is supported, then CPUID. (EAX=07H, ECX=0): ECX [bit 5] is enumerated as 1.

Example 3-58. Identification of WAITPKG with CPUID

```

...identify the existence of cpuid instruction
...;
...;
Identify signature is genuine Intel ...;
mov eax, 7; Request for feature flags
mov ecx, 0; Request for feature flags
cpuid; 0FH, A2H CPUID instruction
test ecx, 00000020h;
Is waitpkg bit (bit 5) in feature flags equal to 1 jnz Found

```

3.13.1.2 User-Level Monitor, User-Level MWAIT, and TPAUSE Operations

User-level monitor initializes the monitor hardware in such a way that, after execution of the user-level MWAIT, a store to a monitored address acts as a wake-up event. So, the User level monitor and the user-

level MWAIT work together to obtain a sleep state. TPAUSE is a single instruction request to enter one of the same two sleep states for a defined time

There are possibilities of a “false wake-up” because of other events, notably interrupts or timeouts. The application may re-execute user-level MWAIT/TPAUSE if it has been falsely woken. If the application needs to determine the source of the predefined OS sleep wakeup, RFLAGS.CF is set. Otherwise it is assumed that the application can detect changes at the monitored address (MWAIT) or poll for activity (TPAUSE).

3.13.1.3 Recommended usage

A frequent paradigm in packet processing applications is to have dedicated HW threads polling a NIC receive descriptor ring for ingress traffic. This kind of “busy polling” arrangement wastes energy when the traffic rates are low. Changing the polling loop to perform user-level Monitor/ MWAIT on the next descriptor to be written can save substantial power in periods of low traffic. The same scheme could be used with any “work distributor,” which assigns work by writing to selected memory locations.

Accelerators frequently offload tasks from SW in an asynchronous manner. For example, the Data Streaming Accelerator (DSA) performs copy operations and can return the status of the completed operation by writing to memory. If an application uses the user-level monitor/MWAIT, at a memory location where the status field will be written, it can be woken when the task is complete.

Instead of monitoring, the device may issue an interrupt that can act as a wake-up event.

Alternatively, applications may decide to choose TPAUSE as a wait event. This has the advantage of being independent of the number of event sources.

In all cases, a small change in the user space application is needed to convert a busy poll application to something more energy efficient with low latency wake-up.

Synchronous application: when two hardware threads from the same core use User level monitor and user-level MWAIT, it can progress effectively as some of the hardware resources are available to the other thread when a hyperthread issues the user-level MWAITS.

To achieve the best performance using user-level monitor and user-level MWAIT:

- The entire contents of monitored locations must be verified after user-level MWAIT to avoid false wake-up.
- It is the developer’s responsibility to check the contents of monitored locations
 - before issuing monitor
 - before issuing user-level MWAIT
 - after user-level MWAIT. See Example 3-59 below.
- If an application expects a store to a monitored location, the timeout value should be as high as it is supported.

Since user-level MWAIT and TPAUSE are a hint to a processor, a user should selectively identify locations in the application.

Example 3-59. Code Snippet in an Asynchronous Example

```
void * m_address; // it is expected device will update m_address to 1
unsigned char ret;
while (1) {
    if (*m_address != 0) // if device already finished operation, no need to user monitor/user mwait
        break;
    if (*m_address == 0) { // check monitored location before issuing umonitor instruction
        _umonitor (m_address);
        if (*m_address == 0) { // check monitored location before issuing umwait instruction
            ret = _umwait(0, 0x186A0); // some high value in timeout
        }
    }
}
```

This chapter gives an overview of features relevant to software optimization for current generations of Intel Atom® processors¹.

4.1 GRACEMONT MICROARCHITECTURE

The Gracemont microarchitecture builds on the success of the Tremont microarchitecture. Listed below are some of the many enhancements provided by the Gracemont microarchitecture.

- Enhanced branch prediction unit.
- Larger 64KB Instruction Cache with dual 32B reads (32B read per fetch cluster).
- Replaced shared second level predecode cache with an On-Demand Instruction Length Decoder per fetch cluster.
- Dynamic Load Balancing between the two fetch clusters.
- Wider allocation and retirement width.
- Larger load and store buffers.
- Dual load and dual store execution pipes.
- Four integer ALU execution ports with expanded capabilities.
- Two jump execution ports.
- Dual integer multiply and integer divide units.
- Improved Intel® SHA-NI and AES latency for enhanced cryptographic performance.
- 256-bit advanced vector extension (Intel® AVX and Intel® AVX2).
- BMI1, BMI2, ADX, LZCNT ISA extensions.
- VEX-based VNNI ISA extension.
- Control-flow enforcement technology (CET) for enhanced protection against malware.

4.1.1 Gracemont Microarchitecture Overview

The basic pipeline functionality of the Gracemont microarchitecture is depicted Figure 4-1.

1. For previous generations of Intel Atom® processors, see Appendix F, “Earlier Generations of Intel Atom® Microarchitecture and Software Optimization.”

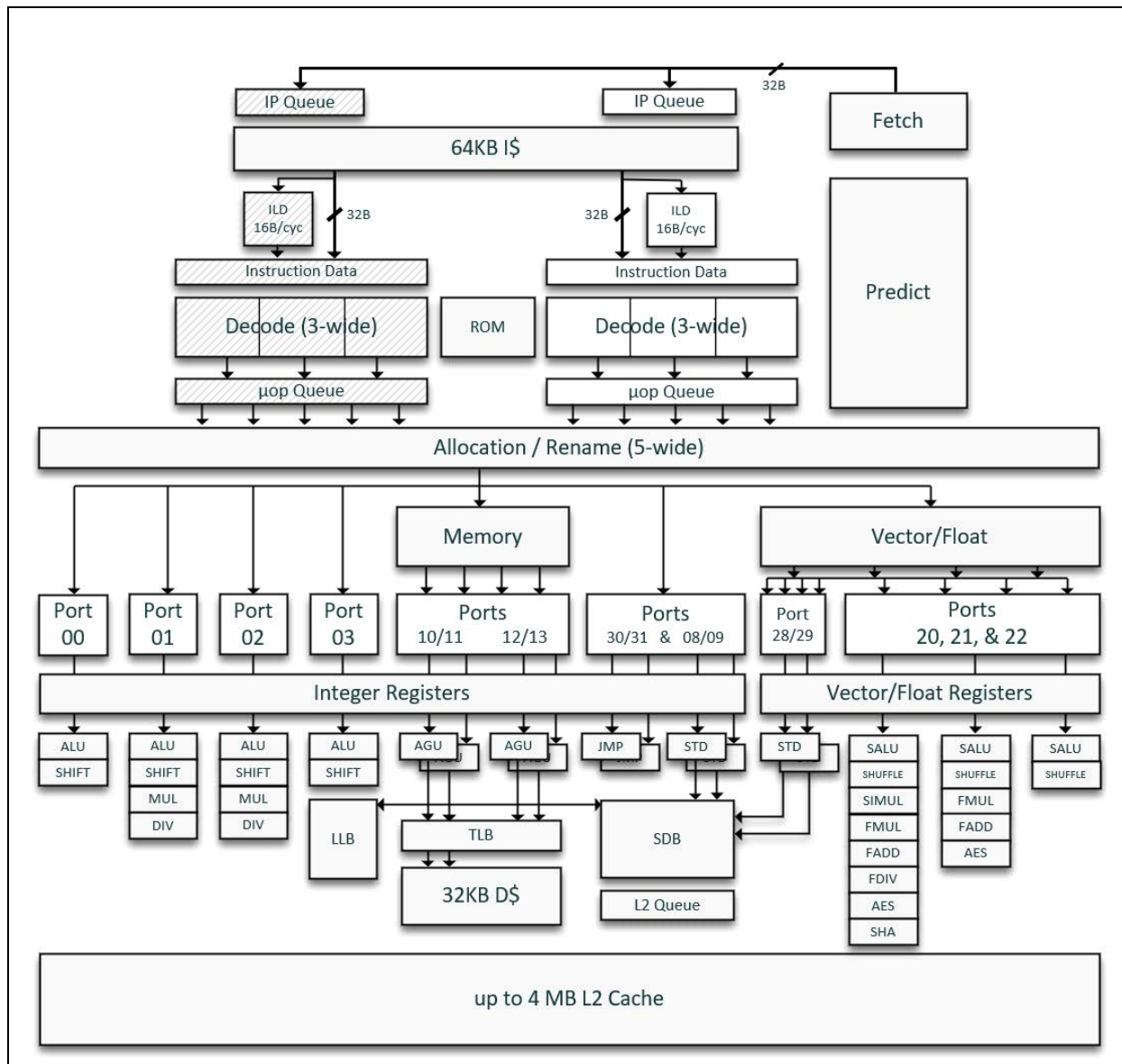

Figure 4-1. Processor Core Pipeline Functionality of the Gracemont Microarchitecture

The Gracemont microarchitecture supports flexible integration of multiple processor cores with a shared uncore subsystem consisting of a number of components including a ring interconnect to multiple slices of L3, processor graphics, integrated memory controller, interconnect fabrics, and more.

4.1.2 Predict and Fetch

The Gracemont microarchitecture features a front end with 32-byte prediction. The first predictor is the next-line predictor (NLP) which can predict a taken branch every cycle and fetch it without bubbles. The NLP is backed by the second predictor that includes a 5K entry target array combined with path-based information to make predictions and verify target addresses in three cycles. Finally, instruction decode can also redirect the front end when it decodes a branch that was not present in any of the predictors. The front-end pipeline functionality of the Gracemont microarchitecture is shown in Figure 4-2.

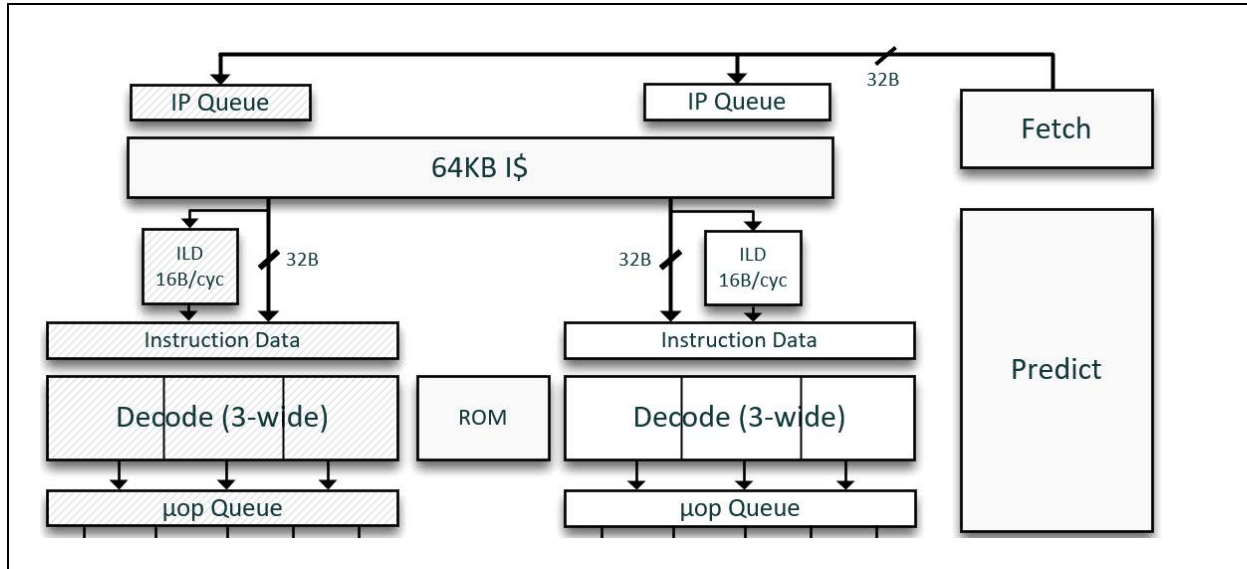

Figure 4-2. Front-End Pipeline Functionality of the Gracemont Microarchitecture

Each cycle, the predicted IP is sent down the instruction fetch pipeline. These predictions can look up the Instruction TLB (ITLB) and the instruction cache tag to determine the physical address and instruction cache hit or miss. Upon successful translation, and depending on resource availability, these accesses are then stored into the instruction pointer (IP) queues. This enables the decoupling instruction cache hit/miss from delivering raw instruction bytes to the rest of the front end. In the case of an instruction cache miss, the IP queue holds the address but signals that the data cannot be read until it is returned from the memory subsystem. The stream of IPs generated at fetch can handle up to 8 concurrent instruction cache misses. There are two independent IP queues, each with their own instruction data buffers. These, combined with their associated decoders, are referred to as clusters. For each taken branch or inserted toggle point, prediction will toggle back and forth between each of the IP queues and therefore each cluster. This toggling enables out-of-order decode, which is the key feature that enables this microarchitecture to fetch and decode up to 6 variable length x86 instructions per cycle.

Performance debug of prediction or fetch can be done utilizing the front-end bound events in the top-down category of performance monitoring events found at <https://perfmon-events.intel.com>. Front-end bound events count slots at allocation only when there are slots available but no uops present. If bubbles caused by the three-cycle predictor percolate all the way to allocation, for example, these will be represented by TOPDOWN_FE_BOUND.BRANCH_RESTEER. You can precisely tag the instruction following such a bubble via FRONTEND_RETIRED.BRANCH_RESTEER. If the predictor failed to cache a branch target and redirection occurred during decode, those slots are counted by TOPDOWN_FE_BOUND.BRANCH_DETECT. If uops are not delivered due to misses in the Instruction Cache or Instruction TLB, these appear as TOPDOWN_FE_BOUND.ICACHE and TOPDOWN_FE_BOUND.ITLB, respectively. Similar to BRANCH_RESTEER, all front-end bound slot-based accounting can be tracked precisely via the corresponding FRONTEND_RETIRED set of events. The instruction code can often be rearranged to optimize such a bottleneck away. Multiple event classes can be tracked simultaneously (e.g., mark both ICACHE and ITLB events) on the same general purpose performance counter or with different events across multiple performance counters.

Sometimes a loop of code is simply too short and/or poorly aligned within the cache to enable the machine to decode sufficiently fast. In this situation you could be fetching every cycle and never inserting bubbles, but still unable to keep the back-end fed. When this happens, the event class that detects this is TOPDOWN_FE_BOUND.OTHER. The "other" event class catches front-end bound behavior that cannot be pinpointed to any of the other specific sources.

4.1.3 Dynamic Load Balancing

One unique performance issue for a microarchitecture of clustered decoders can occur when very long basic blocks are executed. Compilers will sometimes unroll loops of code and generate blocks that can be hundreds of instructions long, trying to provide additional parallelism and reduce the overhead of loops. This is very common for some compilers for floating point and vector processing. Since the method of clustering relies on toggle points, inserting unconditional JMP instructions to the next sequential instruction pointer could have been employed by handwritten assembly using the Tremont microarchitecture. Such insertions should no longer be necessary on Gracemont microarchitecture and beyond. Gracemont microarchitecture addresses this bottleneck by introducing a hardware load-balancer. When the hardware detects long basic blocks, additional toggle points can be created based on internal heuristics. These toggle points are added to the predictors, thus guiding the machine to toggle within the basic block.

In Intel microarchitecture, nearly all basic compute instructions are a single uop. Even complex instructions like CET enabled CALLs are still decoded into a single uop. The high-level algorithm of the load balancer is based on the number of uops present in a sequential stream of instruction bytes. If there are no natural toggle points (i.e., taken branches) within 32 uops, the hardware will insert a toggle point on the instruction after or corresponding to the 24th uop of the stream. As inserted toggle points consume resources in the predictor, it typically doesn't insert immediately but rather marks the location of the instruction in a table of addresses. If the same inserted toggle point is marked a second time, it allocates this location into the predictor.

Sometimes the number of sequential uops leading up to a single toggle point is dynamic. A conditional branch that is not taken can later change to be always taken, for example. In situations such as this, if the location of an inserted toggle point is no longer located at the end of a long uop sequence, it is typically removed. Also, since this algorithm is uop based, instructions that are implemented as long micro-coded sequences of many uops often trigger the insertion of toggle points. This is advantageous as it ensures that decode behavior continues underneath this activity.

4.1.4 Decode and the On-Demand Instruction Length Decoder

The Gracemont microarchitecture stores a single bit for each byte in the instruction cache that marks an instruction boundary, often referred to as a predecode bit. This bit is used to steer instruction bytes into decoder lanes. For native variable length encoding, finding each additional instruction can be considered as having to decode one instruction, feed that information into the decode of the next instruction, and so on. As this function gets wider, the cost of this rapidly increases. With the use of predecode bits, the decoding of the instructions is removed from this path. With the clustered decode approach, when implemented with three wide decoders, the hardware never has to look beyond finding the end of a third serial instruction. This results in instruction muxing and decoding that can be implemented in a very small area and with very low power.

One potential weakness can be determining the predecode bits and using those to mark the instruction boundaries. An additional change from the Tremont microarchitecture is the removal of the large (128KB) shared second level predecode cache. This cache helped seed the first level predecode cache whenever there were misses in the first level instruction cache. While this handled the majority of performant cases, loops of critical code with a footprint exceeding 1MB+ could still suffer additional front-end bottlenecks due to low decode bandwidth from incorrect predecode bits. This could be seen via the event `TOPDOWN_FE_BOUND.PREDECODE`.

Instead of a second level predecode cache, the Gracemont microarchitecture introduces an "on-demand" instruction length decoder (OD-ILD). This block is typically only active when new instruction bytes are brought into the instruction cache from a miss. When this happens, two extra cycles are added to the fetch pipeline in order to generate predecode bits on the fly. These are done across 16 bytes per cycle. With clustering, this means the Gracemont microarchitecture is capable of 32 bytes per cycle across the two independent OD-ILDs. While many workloads will not notice a difference in behavior between the Gracemont and Tremont microarchitectures, large code footprint workloads may see large benefits. This overall approach to x86 instruction decoding provides a clear path forward to very wide designs without needing to cache post-decoded instructions.

Each instruction decoder generates a single uop yet can generate the majority of all x86 code as measured by dynamic instruction count. Load-op-stores, complicated addressing forms, Control Enforcement Technology (CET) instructions, and many more types are generated in a single internal uop format. Each decoder is also capable of detecting a microcode entry point. The most common short microcode flows can be executed out of order between the clusters, enabling additional performance. All uops are written into two parallel uop queues, which are designed to allow the front end and the back end of the core to execute independently. The allocation and rename pipeline reads both uop queues in parallel and puts the instruction stream back in-order for register renaming and resource allocation.

The low-level characteristics of the microarchitecture within each decode cluster remain the same as in the Tremont microarchitecture. For example, instructions should avoid more than 4 bytes of prefixes and escapes. Refer to the previous generation documentation in Appendix F, “Earlier Generations of Intel Atom® Microarchitecture and Software Optimization” for further details.

During performance debug if load balancing or other decode restrictions may be an issue, this will often be indicated by `TOPDOWN_FE_BOUND.DECODE`. If the decoder was struggling due to not having the correct predecode bits or there were too many prefixes or escapes on the instructions, this will be represented by `TOPDOWN_FE_BOUND.PREDECODE`. If the machine is stuck waiting on lengthy microcode sequences, this will be represented by `TOPDOWN_FE_BOUND.CISC`. As with all other allocation slot-based `FE_BOUND` events, there are corresponding `FRONTEND_RETIRED` events that mark an instruction after the designated event class has occurred. However, there is a difference in how this is reported for `CISC` events. As slot-based bottlenecks due to executing long microcoded instructions are typically seen “within” an instruction, `FRONTEND_RETIRED.CISC` will often tag the `CISC` instruction itself and not the instruction that follows. When microcode is invoked to handle external interrupts, faults, traps, or other types of assists, `FRONTEND_RETIRED.CISC` will mark the next instruction that follows.

4.1.5 Allocation and Retirement

The Gracemont microarchitecture is capable of allocating up to five uops per cycle. Allocation reads the uop queues of all front-end clusters simultaneously and generates an in-order stream splicing across clustering boundaries within the same cycle as necessary. For some cases, there can be an expansion between the format inside the uop queue and the format that is allocated into the machine. For example, for a 256-bit Intel AVX instruction, the front-end decodes the instruction as a single uop that is subdivided into 128-bit operations at allocation time. In this case, two allocation lanes are used in order to allocate the two 128-bit halves of the instruction. The most common uops that use this method besides the 256-bit Intel AVX uops are integer uops that require multiple logical register destinations, like integer multiplies and divides. Another example is `PUSH` memory, which loads a value from memory from one address, stores the value into memory at the location of the stack pointer, and updates the stack pointer. If an operation needs two allocation lanes, and it appears on the last (5th) allocation lane, then the hardware will allocate the first piece in the first cycle, and then allocate the second piece in the next cycle, along with up to 4 additional uops. Move elimination, `NOP` detection and idiom detection (e.g., `XOR` a register by itself, producing all zeros), and memory renaming are performed at allocation time. This can reduce dependency chains and, in some situations, eliminate uops from execution.

Retirement can be up to eight instructions per cycle for the 256-entry retirement buffer. Retirement is wider than allocation to improve performance for things like store deallocation along with other less common flushing conditions. This is a feature that leads to better energy efficiency. The cost of widening retirement is relatively small. In turn, the core is able to have smaller, shallower structures because the lifetime of the operation ends up being reduced.

4.1.6 The Out-of-Order and Execution Engines

The Out-of-Order and execution engines changes in the Gracemont microarchitecture include:

- A significant increase in size of the reorder buffer, load buffer, store buffer, and reservation stations, which enable deeper OOO execution and higher cache bandwidth.
- Wider machine: 10→17 execution ports.
- Greater capabilities per execution port.

The execution pipeline functionality of the Gracemont microarchitecture is shown in Figure 4-3.

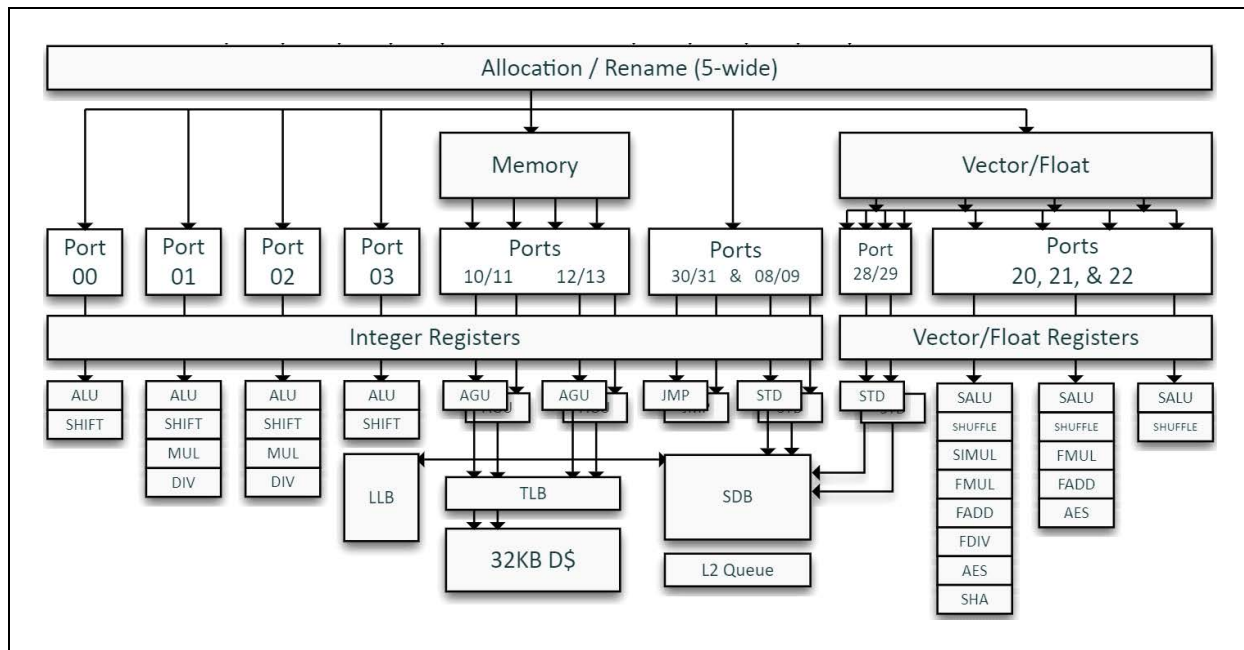

Figure 4-3. Execution Pipeline Functionality of the Gracemont Microarchitecture

Allocation delivers uops to three types of structures. For pure integer operations, each uop is written into one or more of five reservation stations. These hold instructions, track their dependencies, and schedule them for execution. Four are for ALU operations, labeled ports 00 to 03. These execution units are mostly symmetric for single cycle operations. Two of the four ports (01 and 02) can execute longer latency operations like multiplies and divides. The fifth integer reservation station holds jumps and store data operations. This structure is banked and can schedule two uops of each type every cycle; two store data on ports 08 and 09, and two jumps on ports 30 and 31. Complex instructions like an ADD where one source and the destination are in memory, are decoded by the front-end and allocated as a single uop. The Gracemont microarchitecture can allocate five instructions like these per cycle. However, such uops break up into multiple pieces as they enter the back end. In this example, this single complex uop generates a load, an add, a store address operation, and a store data operation. These pieces execute independently in the out-of-order machine and require four different dispatch ports.

Load Effective Address operations (LEAs) are special and deserve extra attention. The ALU ports are optimized to execute standard two source arithmetic/logical operations while the AGUs are optimized to handle the complexities of x86 memory addressing. LEAs are ALU operations that can have the same complex characteristics as AGU operations. LEAs without a scaled index and with only two sources among base, index, and displacement execute as a normal ALU operation on any port (00 through 03). LEAs with three sources fracture into two operations and take an additional cycle of latency. LEAs with a scaled index but without a displacement execute as a single operation but are statically bound to port 02.

Allocation can also write into a memory queue. This is a FIFO queue that enables deeper buffering of the microarchitecture at a very low implementation cost. The memory queue can then write into a unified reservation station that holds load and store address generation operations. This reservation station can generate two load (ports 10 and 11) and two store address (ports 12 and 13) calculations per cycle. The memory queue also writes the load and store uops into the memory subsystem to perform translation as well as data cache access.

Finally, allocation can write the vector queue. This is where all vector SIMD and floating-point ALU operations go. This FIFO queue can then write into either a unified reservation with three scheduling pipelines (ports 20, 21, and 22), or a store data reservation station capable of dispatching two store data per cycle (ports 28 and 29). The vector unit can execute any combination of two floating-point multiplies, adds, or multiply-add operations. In total, this enables a peak of 16 single precision or 8 double precision FLOPS

per cycle. It can also execute up to three SIMD integer ALU or shuffle operations along with dedicated AES and SHA units.

4.1.7 Cache and Memory Subsystem

The cache hierarchy changes in the Gracemont microarchitecture include:

- 2x total peak load and store bandwidth.
 - Two dedicated load ports.
 - Two dedicated store ports.
- Simultaneous handling of more loads and stores enabled by enlarged buffers.
- 4-cycle load-to-use latency.
- Pipelined Page Miss Handler capable of handling 4 concurrent page walks.
- Increased support for large page translations throughout the paging hierarchy.
- Larger 2nd level TLB.
- L2 cache size support from 2MB to 4MB depending on product design choice:
 - The L2 cache size on processors based on the Alder Lake performance hybrid architecture is 2MB.

The Gracemont microarchitecture memory subsystem is designed to handle two 16 byte loads and two 16-byte stores per cycle, providing simultaneous 32 bytes of read bandwidth and 32 bytes of write bandwidth per cycle. The load to use latency for loads is typically four cycles. When performing a pointer chasing operation where the address being computed is the result of a single prior load and a positive displacement of no more than +1023, the load to use latency observed can be reduced to 3 cycles. The L1 data cache is dual ported to eliminate potential bank conflicts.

Memory disambiguation is supported, which allows loads to execute while older stores have unresolved addresses. Loads that forward from stores can do so in the same load to use latency as cache hits for cases where the store's address is known, and the store data is available. Precise blocking and scheduling are done for cases where the store address or data is not immediately available, and the hardware has determined that these are likely to be related addresses.

Address translations are performed through the first level DTLB, which is fully associative. On Gracemont microarchitecture, 2MB translations are natively cached within the first level DTLB. The DTLB is backed by two second level TLB (STLB) structures shared between code and data requests. The main STLB is 2048 entries 4-way set associative and caches 4KB and 2MB translations. Additionally, Gracemont microarchitecture has an 8-entry fully associative structure for GB translations. STLB misses are sent to the page miss handler (PMH) which is pipelined such that it can perform up to four walks in parallel.

Table 4-1. Paging Cache Parameters of the Gracemont Microarchitecture

Level	Entries	Associativity	Architectural Page Size	Cached Translation Size
ITLB	64	Fully associative	All	4KB, 256KB
DTLB	32	Fully associative	All	4KB, 2MB
STLB	2048	4-way	4K/2M/4M	4KB, 2MB
STLB	8	Fully associative	1GB	1GB

There are three independent L1 prefetchers. One does a simple next-line fetch on DL1 load misses. The second is an instruction pointer based prefetcher capable of detecting striding access patterns of various sizes. This prefetcher works in the linear address space so it is capable of crossing page boundaries and starting translations for TLB misses. The final prefetcher is a next-page prefetcher that detects accesses that are likely to cross a page boundary and starts the access early. L1 data misses generated by these prefetchers communicate additional information to the L2 prefetchers, which help them work together.

The L2 cache delivers 64 bytes of data per cycle at a latency of 17 cycles, and that bandwidth is shared among four cores. The L2 cache subsystem contains multiple prefetchers as well, including a streaming

prefetcher that detects striding access patterns. An additional L2 prefetcher attempts to detect more complicated access patterns. These prefetches can also be generated such that they only fill the LLC but do not fill into the L2 to help reduce DRAM latency.

The L2 cache subsystem of a single 4-core module can have 64 requests and 16 L2 data evictions outstanding on the fabric. These are competitively shared among the cores with per-core reservations to ensure fairness.

4.1.8 Intel® AVX and Intel® AVX2 Instruction Support

The Gracemont microarchitecture supports Intel AVX and Intel AVX2 instructions. The majority of all 256-bit Intel AVX and Intel AVX2 instructions are decoded as a single instruction and stored as a single uop in the front-end pipeline. To execute 256-bit instructions on native 128-bit vector execution and load data paths, most 256-bit uops are further subdivided into two independent 128-bit uops at allocation before insertion into the MEC and FPC reservation stations. These two independent uops are usually assigned to different execution ports such that both may execute in parallel. In general, 256-bit uops consume twice the allocation, execution, and retirement resources compared to 128-bit uops.

While most 256-bit Intel AVX2 instructions can be decomposed into two independent 128-bit micro-operations, a subset of Intel AVX2 instructions, known as cross-lane operations, can only compute the result for an element by utilizing one or more sources belonging to other elements. For example, when some or all of the upper 128-bit result [255:128] is dependent on one or all of a lower element segment [127:0]. These 256-bit cross-lane instructions execute with longer latency and/or reduced throughput compared to their 256-bit non-cross-lane counter-parts.

4.1.8.1 256-bit Permute Operations

The instructions listed below use more operand sources than can be natively supported by a single reservation station within the Gracemont microarchitecture. They are decomposed into two uops where the first uop resolves a subset of operand dependences across 2 cycles. The dependent second uop executes the 256-bit operation by using a single 128-bit execution port for two consecutive cycles with a 5-cycle latency for a total latency of 7 cycles.

- VPERM2I128 ymm1, ymm2, ymm3/m256, imm8
- VPERM2F128 ymm1, ymm2, ymm3/m256, imm8
- VPERMPD ymm1, ymm2/m256, imm8
- VPERMPS ymm1, ymm2, ymm3/m256
- VPERMD ymm1, ymm2, ymm3/m256
- VPERMQ ymm1, ymm2/m256, imm8

4.1.8.2 256-bit Broadcast with 128-bit Memory Operand

The memory versions of the broadcast instructions listed below have a single 128-bit or less memory source operand. They have a single SIMD ALU uop in addition to load operand. The register version of the same instructions is decomposed into two SIMD ALU uops.

Operation portion latency is 1 cycle in addition to load operation latency.

- VBROADCASTSD ymm1, m64
- VBROADCASTSS ymm1, m32

4.1.8.3 256-bit Insertion, Up-Conversion Instructions with 128-bit Memory Operand

The memory versions of the instructions listed below have a single 128-bit or less memory source operand. They are decomposed into two uops. However, the second micro-operation has a dependence on the first micro-operation for the memory version. The second micro-operation of the register version

of the same instruction does not have dependence on the first micro-operation. The register version of the same instructions can execute the upper and lower 128-bit segments in parallel.

Operation portion latency is 2 cycles in addition to load operation latency for the 256-bit insert, packed move with zero and sign extension instructions listed below.

- VPMOVZX ymm1, m128/64/32
- VPMOVSX ymm1, m128/64/32
- VINSERTI128 ymm1, ymm2, m128, imm8
- VINSERTF128 ymm1, ymm2, m128, imm8

Operation portion latency is 6 cycles in addition to load operation latency for the up-convert instructions listed below.

- VCVTQ2PD ymm1, m128
- VCVTDQ2PD ymm1, m128
- VCVTQ2PS ymm1, m128

4.1.8.4 256-bit Variable Blend Instructions

The VBLENDVPD and VBLENDVPS instructions listed below are implemented as micro-coded flow. Throughput is 1 every 4 cycles, and latency is 3 cycles.

- VBLENDVPD ymm1, ymm2, ymm3/m256, ymm4
- VBLENDVPS ymm1, ymm2, ymm3/m256, ymm4

4.1.8.5 256-bit Vector TEST Instructions

The 256-bit vector TEST instructions listed below are decomposed into two uops with dependence between them. Operation result is written in the GPR arithmetic flags. Throughput is one per cycle, and latency is 7 cycles.

- VTESTPS ymm1, ymm2/m256
- VTESTPD ymm1, ymm2/m256
- VPTEST ymm1, ymm2/m256

4.1.8.6 GATHER Instructions

The VGATHER instructions are implemented as micro-coded flow. Latency is ~50 cycles.

4.1.8.7 Masked Load and Store Instructions

Throughput of 256-bit VMASKMOV load and store is one every two cycles. Throughput of 128-bit VMASKMOV load and store is one per cycle. A masked load or store with masked element may encounter performance degradation if the masked element memory access causes an exception or a fault.

4.1.8.8 ADX Instructions

ADX instructions are supported. ADCX and ADOX are partial arithmetic flag updating instructions. Intel Core microarchitecture renames and tracks arithmetic flags differently than Intel Atom. The carry flag (CF), overflow flag (OF), and other flags (ZF, AF, PF, SF) are renamed as if independent registers on Core while they remain as a single register on Atom. Unless there is a non-flag consuming full flag updating instruction in between ADCX/ADOX instructions, on Gracemont microarchitecture there is an operand dependency between the ADCX and ADOX instructions as the arithmetic flag register is a source operand of both. As this dependence between ADCX and ADOX instructions does not exist in the Intel Core

microarchitecture, hand tuned binaries exploiting this parallelism exist. While the Gracemont microarchitecture supports the ISA, the parallelism will be lower on the Gracemont microarchitecture.

4.1.8.9 BMI1, BMI2, and LZCNT Instructions

The bit manipulation instructions BMI1 and BMI2, and the LZCNT instruction are supported.

4.2 TREMONT MICROARCHITECTURE

The Tremont microarchitecture builds on the success of the Goldmont Plus microarchitecture and provides the following enhancements:

- Enhanced branch prediction unit.
 - Increased capacity with improved path-based conditional and indirect prediction.
 - New committed Return Stack Buffer.
- Novel clustered 6-wide out-of-order front-end fetch and decode pipeline.
 - Banked ICache with dual 16B reads.
 - Two 3-wide decode clusters enabling up to 6 instructions per cycle.
- Deeper back-end out-of-order windows.
- 32KB data cache.
- Larger load and store buffers.
- Dual generic load and store execution pipes capable of 2 loads, 2 stores, or 1 load and 1 store per cycle.
- Dedicated integer and vector integer/floating point store data ports.
- New and improved cryptography.
 - New Galois-field instructions (GFNI).
 - Dual AES units.
 - Enhanced SHA-NI implementation.
 - Faster PCLMULQDQ.
- Support for user level low-power and low-latency spin-loop instructions UMWAIT/UMONITOR and TPAUSE.

4.2.1 Tremont Microarchitecture Overview

The basic pipeline functionality of the Tremont microarchitecture is depicted in Figure 4-4.

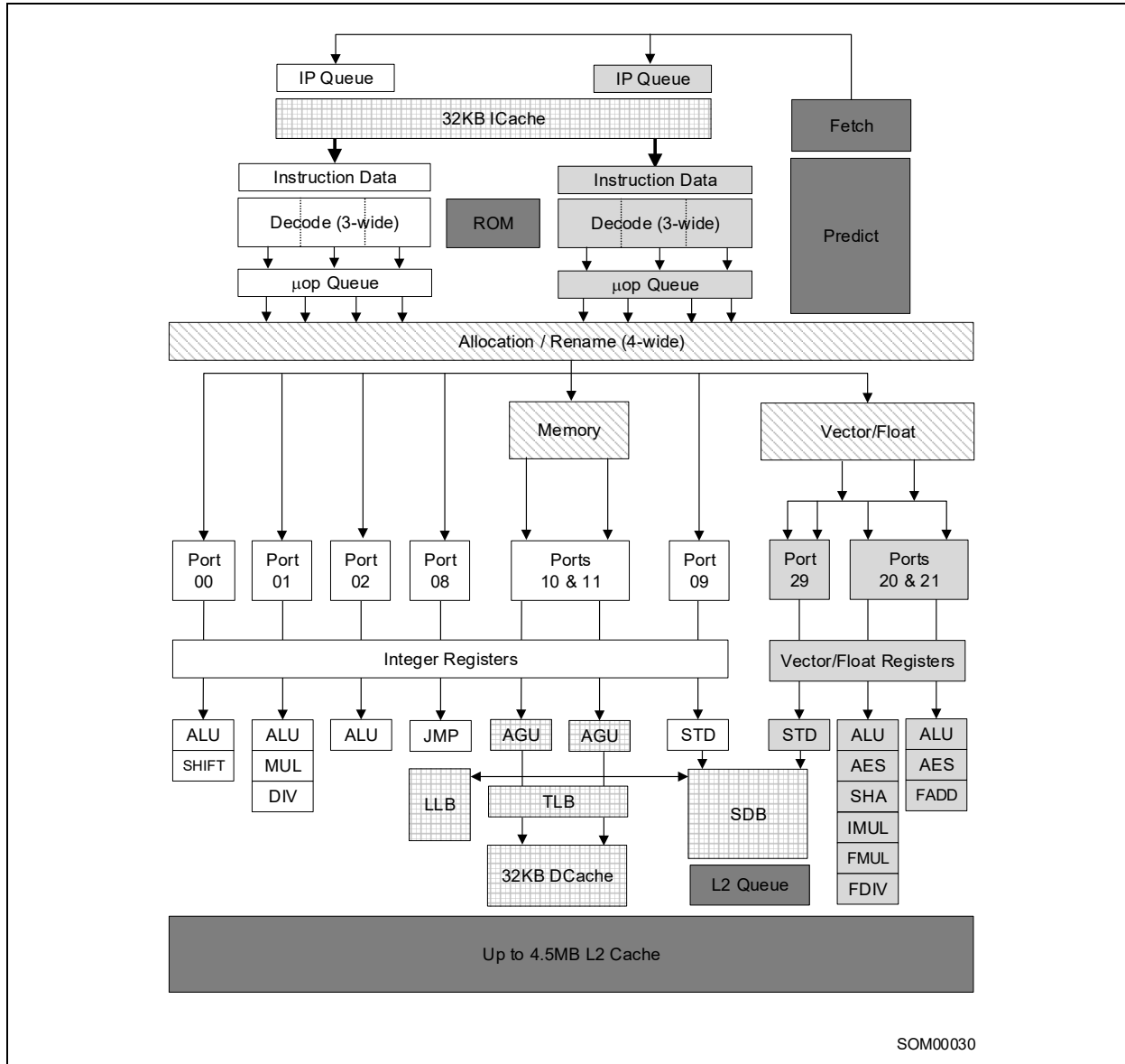

Figure 4-4. Processor Core Pipeline Functionality of the Tremont Microarchitecture

The Tremont microarchitecture supports flexible integration of multiple processor cores with a shared uncore sub-system consisting of a number of components including a ring interconnect to multiple slices of L3, processor graphics, integrated memory controller, interconnect fabrics, and more.

4.2.2 The Front End

Tremont microarchitecture introduces parallel out-of-order instruction decode. Instruction pointers access the ITLB, check the ICache tag array, and access the branch predictor. When the branch predictor produces a taken branch target, the new block of code advances the decode cluster assignment. Tremont microarchitecture has a 32B predict pipeline that feeds dual 3-wide decode clusters capable of 6 instruction decode per cycle. Each cluster can access a banked 32KB instruction cache at 16B/cycle for a maximum of 32B/cycle. Due to differences in the number of instructions per block and other decode latency differences, younger blocks of code can decode before older blocks. At the end of each decode

cluster is a queue of decoded instructions (µop queue). The allocation and rename pipeline reads both µop queues in parallel and puts the instruction stream back in-order for register renaming and resource allocation. Whereas increasing decode width in a traditional fashion for x86 requires exponential resources and triggers efficiency loss, clustering allows for x86 decode to be built with linear resources and little efficiency loss.

As the clustering algorithm is dependent on the ability to predict taken branches within the branch predictor, very long assembly sequences that lack taken branches (long unrolled code utilizing the floating point unit, for example) can be bottlenecked due to being unable to utilize both decode clusters simultaneously. Inserting unconditional JMP instructions to the next sequential instruction pointer at intervals between 16 to 32 instructions may relieve this bottleneck if encountered. While Tremont microarchitecture did not build a dynamic mechanism to load balance the decode clusters, future generations of Intel Atom processors will include hardware to recognize and mitigate these cases without the need for explicit insertions of taken branches into the assembly code.

In addition to the novel clustered decode scheme, Tremont microarchitecture enhanced the branch predictor and doubled the size of the L2 Predecode cache from 64KB on Goldmont Plus microarchitecture to 128KB.

The low level characteristics of the microarchitecture within each decode cluster remain the same as in the Goldmont Plus microarchitecture. For example, instructions should avoid more than 4 Bytes of prefixes and escapes. Refer to previous generation documentation in Appendix F, “Earlier Generations of Intel Atom® Microarchitecture and Software Optimization” for further details.

4.2.3 The Out of Order and Execution Engines

The Out of Order and execution engines changes in the Tremont microarchitecture include:

- A significant increase in size of reorder buffer, load buffer, store buffer, and reservation stations which enable deeper OOO execution and higher cache bandwidth.
- Wider machine: 8 → 10 execution ports.
- Greater capabilities per execution port.

Table 4-2 summarizes the OOO engine's capability to dispatch different types of operations to ports.

Table 4-2. Dispatch Port and Execution Stacks of the Tremont Microarchitecture

Port 00 INT	Port 01 INT	Port 02 INT	Port 08 INT	Port 09 INT	Port 10	Port 11	Port 20 FP/VEC	Port 21 FP/VEC	Port 29 FP/VEC
ALU LEA ¹ Shift	ALU LEA ² Bit Ops IMUL IDIV POPCNT CRC32	ALU LEA ³	JUMP	Store Data	Load Store Address	Load Store Address	ALU AES SHA-RND FMUL FDIV Shuffle Shift SIMUL GFNI Converts	ALU AES SHA-MSG FADD Shuffle	Store Data

NOTES:

1. LEAs without a scaled index and only two sources (among base, index, and displacement inputs) execute as one operation on any ALU port (00, 01, or 02).
2. LEAs with three sources fracture into two operations and take an additional cycle of latency. Index consuming portion, regardless of scale value, will bind to port 02 while second operation binds to either port 00 or 01.
3. LEAs with a scaled index but without a displacement execute as one operation on port 02.

4.2.4 Cache and Memory Subsystem

The cache hierarchy changes in Tremont microarchitecture include:

- 33% increase in size of the L1 data cache from 24KB to 32KB.
- 2×L1 load bandwidth: 1 dedicated load port 2 generic AGUs, shared between loads and stores.
- 2×L1 store bandwidth: 1 dedicated store port 2 generic AGUs, shared between loads and stores.
- Simultaneous handling of more loads and stores enabled by enlarged buffers.
- Maintains a 3-cycle load-to-use latency.
- Larger 2nd level TLB:
 - 512 4K entries → 1K 4K entries
 - 32 2M/4M entries → 64 2M/4M entries
- L2 cache size from 1MB to 4.5MB depending on SoC design choice:
 - The L2 size on Snow Ridge products is 4.5MB whereas the L2 size on Lakefield products is 1.5MB.

The TLB hierarchy consists of dedicated level one TLB for instruction cache and data cache with a shared second-level TLB for all page translations.

Table 4-3. Cache Parameters of the Tremont Microarchitecture

Level	Page Size	Entries	Associativity
Instruction	4KB/2M/4M ¹	48	Fully associative
First Level Data (loads and stores)	4KB/2M/4M ²	32	Fully associative
Second Level	4KB	1024	4
Second Level	2M/4M	64	4

NOTES:

1. The first level instruction TLB (ITLB) caches small and large page translations but large pages are cached as 256KB regions per ITLB entry.
2. The first level data TLB (uTLB) caches small and large page translations but large pages are fully fractured into 4KB regions per uTLB entry.

4.2.5 New Instructions

New instructions and architectural changes in Tremont microarchitecture are listed below. Actual support may be product dependent.

- Galois Field New Instructions (GFNI) for acceleration of various encryption algorithms, error correction algorithms, and bit matrix multiplications.
- UMWAIT/UMONITOR/TPAUSE instructions enable power savings in user level spin loops.
- Cache line writeback instruction (CLWB) enables fast cache-line update to memory, while retaining clean copy in cache.
- Performance debugging benefits can be realized from the Tremont microarchitecture skidless PEBS implementation on both PMCO as well as the fixed instruction counter. This enables a precise distribution via sampling on instructions and/or any of the precise general purpose events. As PEBS is triggered on the event **after** the overflow is signaled, counters should be programmed to large numbers that are (PRIME-1).

4.2.6 Tremont Microarchitecture Power Management

Tremont microarchitecture supports many of the same features as those found on the Ice Lake Client microarchitecture. Processors based on Tremont microarchitecture are the first Intel Atom processors with support for Intel® Speed Shift Technology. Power management features sometimes differ depending on the needs of the SoC.

CHAPTER 5 CODING FOR SIMD ARCHITECTURES

Processors based on Intel Core microarchitecture support MMX, SSE, SSE2, SSE3, and SSSE3. Processors based on Enhanced Intel Core microarchitecture support MMX, SSE, SSE2, SSE3, SSSE3 and SSE4.1. Processors based on Nehalem microarchitecture support MMX, SSE, SSE2, SSE3, SSSE3, SSE4.1 and SSE4.2. Processors based on Westmere microarchitecture support MMX, SSE, SSE2, SSE3, SSSE3, SSE4.1, SSE4.2 and AESNI. Processors based on Sandy Bridge microarchitecture support MMX, SSE, SSE2, SSE3, SSSE3, SSE4.1, SSE4.2, AESNI, PCLMULQDQ and Intel AVX.

Intel Pentium 4, Intel Xeon and Pentium M processors include support for SSE2, SSE, and MMX technology. SSE3 were introduced with the Pentium 4 processor supporting Hyper-Threading Technology at 90 nm technology. Intel Core Solo and Intel Core Duo processors support SSE3/SSE2/SSE, and MMX.

Single-instruction, multiple-data (SIMD) technologies enable the development of advanced multimedia, signal processing, and modeling applications.

Single-instruction, multiple-data techniques can be applied to text/string processing, lexing and parser applications. This is covered in Chapter 14, "SSE4.2 and SIMD Programming For Text-Processing/Lexing/Parsing." Techniques for optimizing AESNI are discussed in Section 6.10.

To take advantage of the performance opportunities presented by these capabilities, do the following:

- Ensure that the processor supports MMX technology, SSE, SSE2, SSE3, SSSE3 and SSE4.1.
- Ensure that the operating system supports MMX technology and SSE (OS support for SSE2, SSE3 and SSSE3 is the same as OS support for SSE).
- Employ the optimization and scheduling strategies described in this book.
- Use stack and data alignment techniques to keep data properly aligned for efficient memory use.
- Utilize the cacheability instructions offered by SSE and SSE2, where appropriate.

5.1 CHECKING FOR PROCESSOR SUPPORT OF SIMD TECHNOLOGIES

This section shows how to check whether a processor supports MMX technology, SSE, SSE2, SSE3, SSSE3, and SSE4.1.

SIMD technology can be included in your application in three ways:

1. Check for the SIMD technology during installation. If the desired SIMD technology is available, the appropriate DLLs can be installed.
2. Check for the SIMD technology during program execution and install the proper DLLs at runtime. This is effective for programs that may be executed on different machines.
3. Create a "fat" binary that includes multiple versions of routines; versions that use SIMD technology and versions that do not. Check for SIMD technology during program execution and run the appropriate versions of the routines. This is especially effective for programs that may be executed on different machines.

5.1.1 Checking for MMX Technology Support

If MMX technology is available, then `CPUID.01H:EDX[BIT 23] = 1`. Use the code segment in Example 5-1 to test for MMX technology.

Example 5-1. Identification of MMX Technology with CPUID

```

...identify existence of cpuid instruction
...          ;
...          ; Identify signature is genuine Intel
...          ;
mov eax, 1   ; Request for feature flags
cpuid       ; 0FH, 0A2H CPUID instruction
test edx, 00800000h ; Is MMX technology bit (bit 23) in feature flags equal to 1
jnz        Found

```

For more information on CPUID see, *Intel® Processor Identification with CPUID Instruction*, order number 241618.

5.1.2 Checking for Streaming SIMD Extensions Support

Checking for processor support of Streaming SIMD Extensions (SSE) on your processor is similar to checking for MMX technology. However, operating system (OS) must provide support for SSE states save and restore on context switches to ensure consistent application behavior when using SSE instructions.

To check whether your system supports SSE, follow these steps:

1. Check that your processor supports the CPUID instruction.
2. Check the feature bits of CPUID for SSE existence.

Example 5-2 shows how to find the SSE feature bit (bit 25) in CPUID feature flags.

Example 5-2. Identification of SSE with CPUID

```

...Identify existence of cpuid instruction
...          ; Identify signature is genuine intel
mov eax, 1   ; Request for feature flags
cpuid       ; 0FH, 0A2H cpuid instruction
test EDX, 002000000h ; Bit 25 in feature flags equal to 1
jnz        Found

```

5.1.3 Checking for Streaming SIMD Extensions 2 Support

Checking for support of SSE2 is like checking for SSE support. The OS requirements for SSE2 Support are the same as the OS requirements for SSE.

To check whether your system supports SSE2, follow these steps:

1. Check that your processor has the CPUID instruction.
2. Check the feature bits of CPUID for SSE2 technology existence.

Example 5-3 shows how to find the SSE2 feature bit (bit 26) in the CPUID feature flags.

Example 5-3. Identification of SSE2 with cpuid

```

...Identify existence of cpuid instruction
...                ; Identify signature is genuine intel
mov eax, 1         ; Request for feature flags
cpuid              ; 0FH, 0A2H CPUID instruction
test EDX, 00400000h ; Bit 26 in feature flags equal to 1
jnz    Found

```

5.1.4 Checking for Streaming SIMD Extensions 3 Support

SSE3 includes 13 instructions, 11 of those are suited for SIMD or x87 style programming. Checking for support of SSE3 instructions is similar to checking for SSE support. The OS requirements for SSE3 Support are the same as the requirements for SSE.

To check whether your system supports the x87 and SIMD instructions of SSE3, follow these steps:

1. Check that your processor has the CPUID instruction.
2. Check the ECX feature bit 0 of CPUID for SSE3 technology existence.

Example 5-4 shows how to find the SSE3 feature bit (bit 0 of ECX) in the CPUID feature flags.

Example 5-4. Identification of SSE3 with CPUID

```

...Identify existence of cpuid instruction
...                ; Identify signature is genuine intel
mov eax, 1         ; Request for feature flags
cpuid              ; 0FH, 0A2H CPUID instruction
test ECX, 000000001h ; Bit 0 in feature flags equal to 1
jnz    Found

```

Software must check for support of MONITOR and MWAIT before attempting to use MONITOR and MWAIT. Detecting the availability of MONITOR and MWAIT can be done using a code sequence similar to Example 5-4. The availability of MONITOR and MWAIT is indicated by bit 3 of the returned value in ECX.

5.1.5 Checking for Supplemental Streaming SIMD Extensions 3 Support

Checking for support of SSSE3 is similar to checking for SSE support. The OS requirements for SSSE3 support are the same as the requirements for SSE.

To check whether your system supports SSSE3, follow these steps:

1. Check that your processor has the CPUID instruction.
2. Check the feature bits of CPUID for SSSE3 technology existence.

Example 5-5 shows how to find the SSSE3 feature bit in the CPUID feature flags.

Example 5-5. Identification of SSSE3 with cpuid

```

...Identify existence of CPUID instruction
...                ; Identify signature is genuine intel
mov eax, 1         ; Request for feature flags
cpuid              ; 0FH, 0A2H CPUID instruction
test ECX, 000000200h ; ECX bit 9
jnz    Found

```

5.1.6 Checking for SSE4.1 Support

Checking for support of SSE4.1 is similar to checking for SSE support. The OS requirements for SSE4.1 support are the same as the requirements for SSE.

To check whether your system supports SSE4.1, follow these steps:

1. Check that your processor has the CPUID instruction.
2. Check the feature bit of CPUID for SSE4.1.

Example 5-6 shows how to find the SSE4.1 feature bit in the CPUID feature flags.

Example 5-6. Identification of SSE4.1 with cpuid

```

...Identify existence of CPUID instruction
...                ; Identify signature is genuine intel
mov eax, 1         ; Request for feature flags
cpuid              ; 0FH, 0A2H CPUID instruction
test ECX, 00008000h ; ECX bit 19
jnz    Found

```

5.1.7 Checking for SSE4.2 Support

Checking for support of SSE4.2 is similar to checking for SSE support. The OS requirements for SSE4.2 support are the same as the requirements for SSE.

To check whether your system supports SSE4.2, follow these steps:

1. Check that your processor has the CPUID instruction.
2. Check the feature bit of CPUID for SSE4.2.

Example 5-7 shows how to find the SSE4.2 feature bit in the CPUID feature flags.

Example 5-7. Identification of SSE4.2 with cpuid

```

...Identify existence of CPUID instruction
...                ; Identify signature is genuine intel
mov eax, 1         ; Request for feature flags
cpuid              ; 0FH, 0A2H CPUID instruction
test ECX, 00010000h ; ECX bit 20
jnz    Found

```

5.1.8 DetectiON of PCLMULQDQ and AESNI Instructions

Before an application attempts to use the following AESNI instructions: AESDEC/AESDECLAST/AESENC/AESENCLAST/AESIMC/AESKEYGENASSIST, it must check that the processor supports the AESNI extensions. AESNI extensions is supported if CPUID.01H:ECX.AESNI[bit 25] = 1.

Prior to using PCLMULQDQ instruction, application must check if CPUID.01H:ECX.PCLMULQDQ[bit 1] = 1.

Operating systems that support handling SSE state will also support applications that use AESNI extensions and PCLMULQDQ instruction. This is the same requirement for SSE2, SSE3, SSSE3, and SSE4.

Example 5-8. Detection of AESNI Instructions

```

...Identify existence of CPUID instruction
...                ; Identify signature is genuine intel
mov eax, 1         ; Request for feature flags
cpuid              ; 0FH, 0A2H CPUID instruction
test ECX, 00200000h ; ECX bit 25
jnz    Found

```

Example 5-9. Detection of PCLMULQDQ Instruction

```

...Identify existence of CPUID instruction
...                ; Identify signature is genuine intel
mov eax, 1         ; Request for feature flags
cpuid              ; 0FH, 0A2H CPUID instruction
test ECX, 000000002h ; ECX bit 1
jnz    Found

```

5.1.9 Detection of AVX Instructions

Intel AVX operates on the 256-bit YMM register state. Application detection of new instruction extensions operating on the YMM state follows the general procedural flow in Figure 5-1.

Prior to using AVX, the application must identify that the operating system supports the XGETBV instruction, the YMM register state, in addition to processor's support for YMM state management using XSAVE/XRSTOR and AVX instructions. The following simplified sequence accomplishes both and is strongly recommended.

- 1) Detect CPUID.1:ECX.OSXSAVE[bit 27] = 1 (XGETBV enabled for application use¹)
- 2) Issue XGETBV and verify that XFEATURE_ENABLED_MASK[2:1] = '11b' (XMM state and YMM state are enabled by OS).
- 3) Detect CPUID.1:ECX.AVX[bit 28] = 1 (AVX instructions supported).

Note: Step 3 can be done in any order relative to 1 and 2.

1. If CPUID.01H:ECX.OSXSAVE reports 1, it also indirectly implies the processor supports XSAVE, XRSTOR, XGETBV, processor extended state bit vector XFEATURE_ENABLED_MASK register. Thus an application may streamline the checking of CPUID feature flags for XSAVE and OSXSAVE. XSETBV is a privileged instruction.

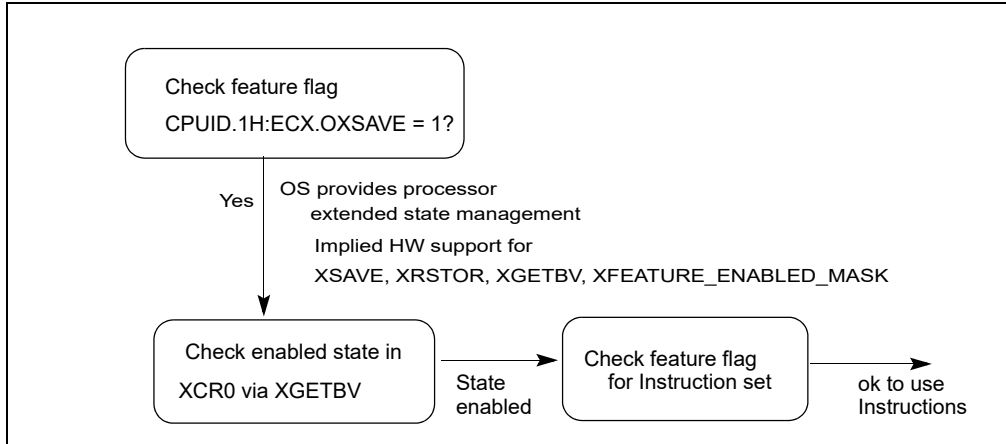

Figure 5-1. General Procedural Flow of Application Detection of AVX

The following pseudocode illustrates this recommended application AVX detection process:

Example 5-10. Detection of AVX Instruction

```

INT supports_AVX()
{
  mov   eax, 1
  cpuid
  and   ecx, 018000000H
  cmp   ecx, 018000000H; check both OSXSAVE and AVX feature flags
  jne   not_supported
  ; processor supports AVX instructions and XGETBV is enabled by OS
  mov   ecx, 0; specify 0 for XFEATURE_ENABLED_MASK register
  XGETBV    ; result in EDX:EAX
  and   eax, 06H
  cmp   eax, 06H; check OS has enabled both XMM and YMM state support
  jne   not_supported
  mov   eax, 1
  jmp   done
NOT_SUPPORTED:
  mov   eax, 0
done:

```

Note: It is unwise for an application to rely exclusively on CPUID.1:ECX.AVX[bit 28] or at all on CPUID.1:ECX.XSAVE[bit 26]: These indicate hardware support but not operating system support. If YMM state management is not enabled by an operating system, AVX instructions will #UD regardless of CPUID.1:ECX.AVX[bit 28]. "CPUID.1:ECX.XSAVE[bit 26] = 1" does not guarantee the OS actually uses the XSAVE process for state management.

5.1.10 Detection of VEX-Encoded AES and VPCLMULQDQ

VAESDEC/VAESDECLAST/VAESENC/VAESENCLAST/VAESIMC/VAESKEYGENASSIST instructions operate on YMM states. The detection sequence must combine checking for CPUID.1:ECX.AES[bit 25] = 1 and the sequence for detection application support for AVX.

Example 5-11. Detection of VEX-Encoded AESNI Instructions

```

INT supports_VAESNI()
{
    mov    eax, 1
    cpuid
    and    ecx, 01A000000H
    cmp    ecx, 01A000000H; check OSXSAVE AVX and AESNI feature flags
    jne    not_supported
    ; processor supports AVX and VEX-encoded AESNI and XGETBV is enabled by OS
    mov    ecx, 0; specify 0 for XFEATURE_ENABLED_MASK register
    XGETBV    ; result in EDX:EAX
    and    eax, 06H
    cmp    eax, 06H; check OS has enabled both XMM and YMM state support
    jne    not_supported
    mov    eax, 1
    jmp    done
NOT_SUPPORTED:
    mov    eax, 0
done:

```

Similarly, the detection sequence for VPCLMULQDQ must combine checking for CPUID.1:ECX.PCLMULQDQ[bit 1] = 1 and the sequence for detection application support for AVX.

This is shown in the pseudocode:

Example 5-12. Detection of VEX-Encoded AESNI Instructions

```

INT supports_VPCLMULQDQ()
{
    mov    eax, 1
    cpuid

    and    ecx, 018000002H
    cmp    ecx, 018000002H; check OSXSAVE AVX and PCLMULQDQ feature flags
    jne    not_supported
    ; processor supports AVX and VEX-encoded PCLMULQDQ and XGETBV is enabled by OS
    mov    ecx, 0; specify 0 for XFEATURE_ENABLED_MASK register
    XGETBV    ; result in EDX:EAX
    and    eax, 06H
    cmp    eax, 06H; check OS has enabled both XMM and YMM state support
    jne    not_supported
    mov    eax, 1
    jmp    done
NOT_SUPPORTED:
    mov    eax, 0
done:

```

5.1.11 Detection of F16C Instructions

Application using float 16 instruction must follow a detection sequence similar to AVX to ensure:

- The OS has enabled YMM state management support.

- The processor support AVX as indicated by the CPUID feature flag, i.e. CPUID.01H:ECX.AVX[bit 28] = 1.
- The processor support 16-bit floating-point conversion instructions via a CPUID feature flag (CPUID.01H:ECX.F16C[bit 29] = 1).

Application detection of Float-16 conversion instructions follow the general procedural flow in Figure 5-2.

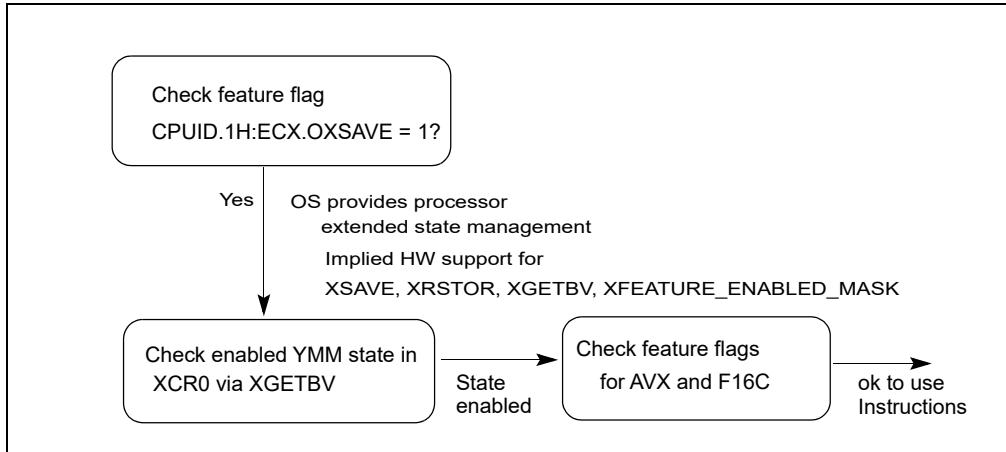

Figure 5-2. General Procedural Flow of Application Detection of Float-16

```

INT supports_f16c()
{
    ; result in eax
    mov eax, 1
    cpuid
    and ecx, 038000000H
    cmp ecx, 038000000H; check OSXSAVE, AVX, F16C feature flags
    jne not_supported
    ; processor supports AVX,F16C instructions and XGETBV is enabled by OS
    mov ecx, 0; specify 0 for XFEATURE_ENABLED_MASK register
    XGETBV; result in EDX:EAX
    and eax, 06H
    cmp eax, 06H; check OS has enabled both XMM and YMM state support
    jne not_supported
    mov eax, 1
    jmp done
NOT_SUPPORTED:
    mov eax, 0
done:
}
  
```

5.1.12 Detection of FMA

Hardware support for FMA is indicated by CPUID.1:ECX.FMA[bit 12]=1.

Application Software must identify that hardware supports AVX, after that it must also detect support for FMA by CPUID.1:ECX.FMA[bit 12]. The recommended pseudocode sequence for detection of FMA is:

```

-----
INT supports_fma()
{
    ; result in eax
    mov eax, 1
    cpuid
    and ecx, 018001000H
    cmp ecx, 018001000H; check OSXSAVE, AVX, FMA feature flags
    jne not_supported
    ; processor supports AVX,FMA instructions and XGETBV is enabled by OS
    mov ecx, 0; specify 0 for XFEATURE_ENABLED_MASK register
    XGETBV; result in EDX:EAX
    and eax, 06H
    cmp eax, 06H; check OS has enabled both XMM and YMM state support
    jne not_supported
    mov eax, 1
    jmp done
NOT_SUPPORTED:
    mov eax, 0
done:
}
-----

```

5.1.13 Detection of AVX2

Hardware support for AVX2 is indicated by CPUID.(EAX=07H, ECX=0H):EBX.AVX2[bit 5]=1.

Application Software must identify that hardware supports AVX, after that it must also detect support for AVX2 by checking CPUID.(EAX=07H, ECX=0H):EBX.AVX2[bit 5]. The recommended pseudocode sequence for detection of AVX2 is:

```

-----
INT supports_avx2()
{
    ; result in eax
    mov eax, 1
    cpuid
    and ecx, 018000000H
    cmp ecx, 018000000H; check both OSXSAVE and AVX feature flags
    jne not_supported
    ; processor supports AVX instructions and XGETBV is enabled by OS
    mov eax, 7
    mov ecx, 0
    cpuid
    and ebx, 20H
    cmp ebx, 20H; check AVX2 feature flags
    jne not_supported
}
-----

```

```
    mov ecx, 0; specify 0 for XFEATURE_ENABLED_MASK register
    XGETBV; result in EDX:EAX
    and eax, 06H
    cmp eax, 06H; check OS has enabled both XMM and YMM state support
    jne not_supported
    mov eax, 1
    jmp done
NOT_SUPPORTED:
    mov eax, 0
done:
}
```

5.2 CONSIDERATIONS FOR CODE CONVERSION TO SIMD PROGRAMMING

The VTune Performance Enhancement Environment CD provides tools to aid in the evaluation and tuning. Before implementing them, you need answers to the following questions:

1. Will the current code benefit by using MMX technology, Streaming SIMD Extensions, Streaming SIMD Extensions 2, Streaming SIMD Extensions 3, or Supplemental Streaming SIMD Extensions 3?
2. Is this code integer or floating-point?
3. What integer word size or floating-point precision is needed?
4. What coding techniques should I use?
5. What guidelines do I need to follow?
6. How should I arrange and align the datatypes?

Figure 5-3 provides a flowchart for the process of converting code to MMX technology, SSE, SSE2, SSE3, or SSSE3.

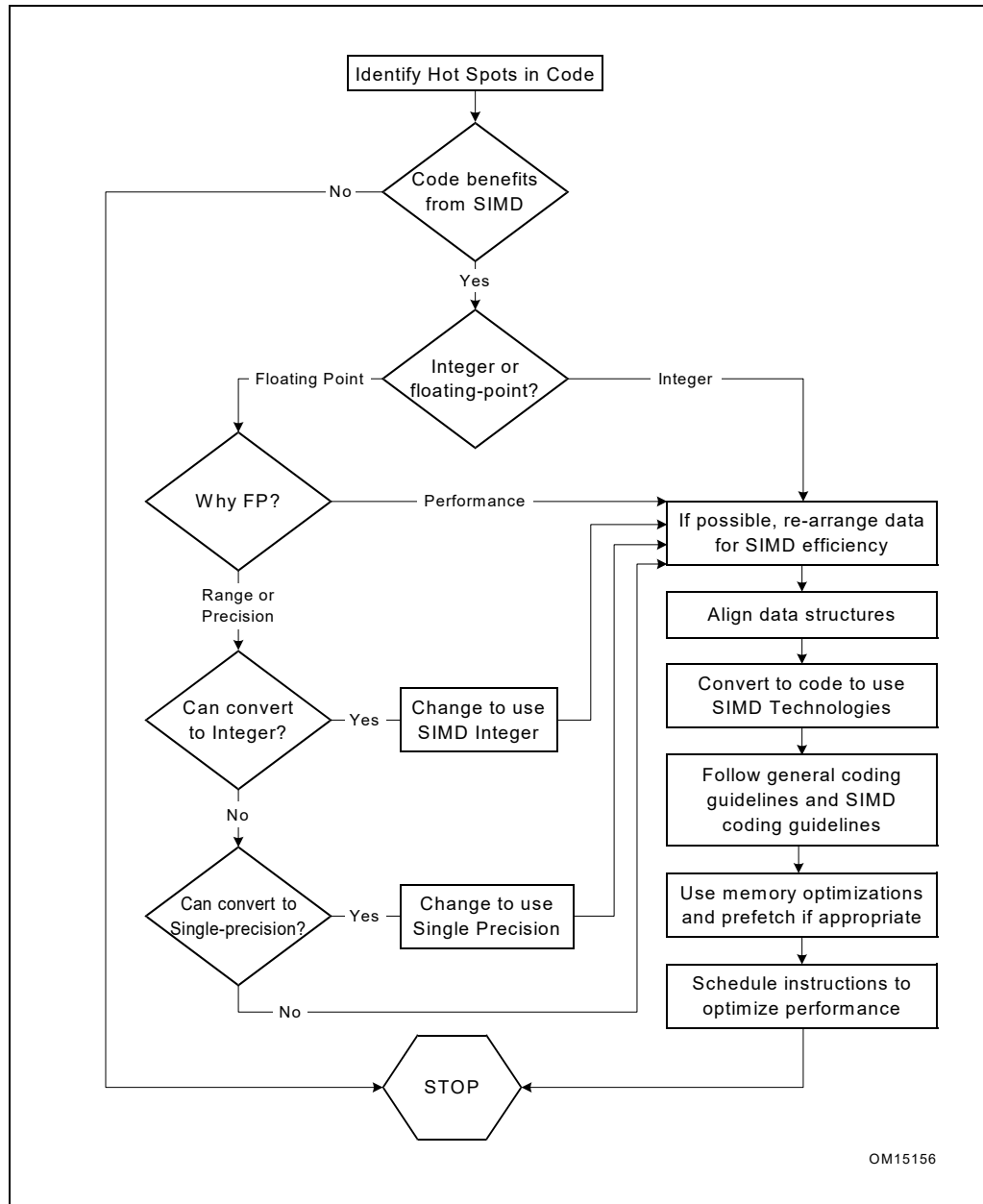

Figure 5-3. Converting to Streaming SIMD Extensions Chart

To use any of the SIMD technologies optimally, you must evaluate the following situations in your code:

- Fragments that are computationally intensive.
- Fragments that are executed often enough to have an impact on performance.
- Fragments that with little data-dependent control flow.
- Fragments that require floating-point computations.
- Fragments that can benefit from moving data 16 bytes at a time.
- Fragments of computation that can coded using fewer instructions.
- Fragments that require help in using the cache hierarchy efficiently.

5.2.1 Identifying Hot Spots

To optimize performance, use the VTune Performance Analyzer to find sections of code that occupy most of the computation time. Such sections are called the hotspots. See Appendix A, “Application Performance Tools.”

The VTune analyzer provides a hotspots view of a specific module to help you identify sections in your code that take the most CPU time and that have potential performance problems. The hotspots view helps you identify sections in your code that take the most CPU time and that have potential performance problems.

The VTune analyzer enables you to change the view to show hotspots by memory location, functions, classes, or source files. You can double-click on a hotspot and open the source or assembly view for the hotspot and see more detailed information about the performance of each instruction in the hotspot.

The VTune analyzer offers focused analysis and performance data at all levels of your source code and can also provide advice at the assembly language level. The code coach analyzes and identifies opportunities for better performance of C/C++, Fortran and Java* programs, and suggests specific optimizations. Where appropriate, the coach displays pseudo-code to suggest the use of highly optimized intrinsics and functions in the Intel® Performance Library Suite. Because VTune analyzer is designed specifically for Intel architecture (IA)-based processors, including the Pentium 4 processor, it can offer detailed approaches to working with IA. See Appendix A.1.1, “Recommended Optimization Settings for Intel® 64 and IA-32 Processors,” for details.

5.2.2 Determine If Code Benefits by Conversion to SIMD Execution

Identifying code that benefits by using SIMD technologies can be time-consuming and difficult. Likely candidates for conversion are applications that are highly computation intensive, such as the following:

- Speech compression algorithms and filters.
- Speech recognition algorithms.
- Video display and capture routines.
- Rendering routines.
- 3D graphics (geometry).
- Image and video processing algorithms.
- Spatial (3D) audio.
- Physical modeling (graphics, CAD).
- Workstation applications.
- Encryption algorithms.
- Complex arithmetics.

Generally, good candidate code is code that contains small-sized repetitive loops that operate on sequential arrays of integers of 8, 16 or 32 bits, single-precision 32-bit floating-point data, double precision 64-bit floating-point data (integer and floating-point data items should be sequential in memory). The repetitiveness of these loops incurs costly application processing time. However, these routines have potential for increased performance when you convert them to use one of the SIMD technologies.

Once you identify your opportunities for using a SIMD technology, you must evaluate what should be done to determine whether the current algorithm or a modified one will ensure the best performance.

5.3 CODING TECHNIQUES

The SIMD features of SSE3, SSE2, SSE, and MMX technology require new methods of coding algorithms. One of them is vectorization. Vectorization is the process of transforming sequentially-executing, or scalar, code into code that can execute in parallel, taking advantage of the SIMD architecture parallelism.

This section discusses the coding techniques available for an application to make use of the SIMD architecture.

To vectorize your code and thus take advantage of the SIMD architecture, do the following:

- Determine if the memory accesses have dependencies that would prevent parallel execution.
- “Strip-mine” the inner loop to reduce the iteration count by the length of the SIMD operations (for example, four for single-precision floating-point SIMD, eight for 16-bit integer SIMD on the XMM registers).
- Re-code the loop with the SIMD instructions.

Each of these actions is discussed in detail in the subsequent sections of this chapter. These sections also discuss enabling automatic vectorization using the Intel C++ Compiler.

5.3.1 Coding Methodologies

Software developers need to compare the performance improvement that can be obtained from assembly code versus the cost of those improvements. Programming directly in assembly language for a target platform may produce the required performance gain, however, assembly code is not portable between processor architectures and is expensive to write and maintain.

Performance objectives can be met by taking advantage of the different SIMD technologies using high-level languages as well as assembly. The new C/C++ language extensions designed specifically for SSSE3, SSE3, SSE2, SSE, and MMX technology help make this possible.

Figure 5-4 illustrates the trade-offs involved in the performance of hand-coded assembly versus the ease of programming and portability.

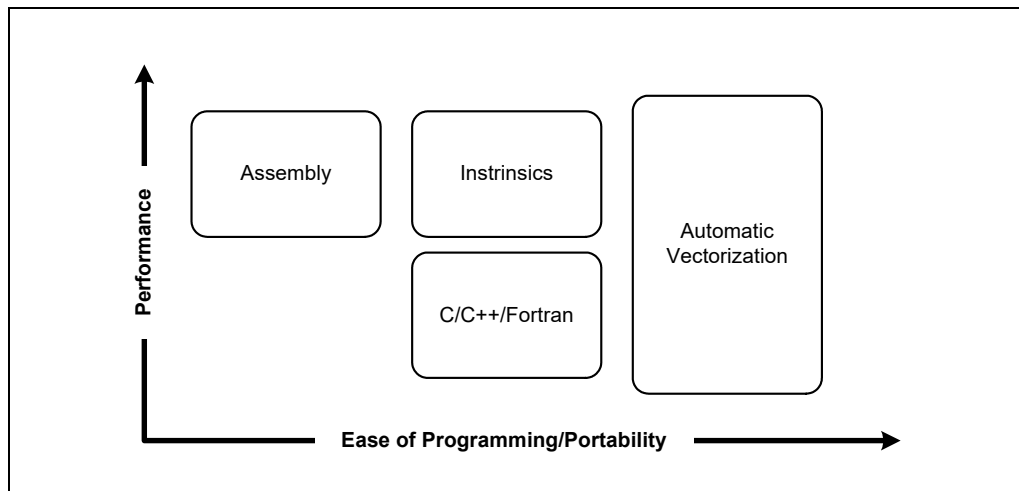

Figure 5-4. Hand-Coded Assembly and High-Level Compiler Performance Trade-offs

The examples that follow illustrate the use of coding adjustments to enable the algorithm to benefit from the SSE. The same techniques may be used for single-precision floating-point, double-precision floating-point, and integer data under SSSE3, SSE3, SSE2, SSE, and MMX technology.

As a basis for the usage model discussed in this section, consider a simple loop shown in Example 5-13.

Example 5-13. Simple Four-Iteration Loop

```
void add(float *a, float *b, float *c)
{
  int i;
  for (i = 0; i < 4; i++) {
    c[i] = a[i] + b[i];
  }
}
```

Note that the loop runs for only four iterations. This allows a simple replacement of the code with Streaming SIMD Extensions.

For the optimal use of the Streaming SIMD Extensions that need data alignment on the 16-byte boundary, all examples in this chapter assume that the arrays passed to the routine, *A*, *B*, *C*, are aligned to 16-byte boundaries by a calling routine. For the methods to ensure this alignment, please refer to the application notes for the Pentium 4 processor.

The sections that follow provide details on the coding methodologies: inlined assembly, intrinsics, C++ vector classes, and automatic vectorization.

5.3.1.1 Assembly

Key loops can be coded directly in assembly language using an assembler or by using inlined assembly (C-asm) in C/C++ code. The Intel compiler or assembler recognize the new instructions and registers, then directly generate the corresponding code. This model offers the opportunity for attaining greatest performance, but this performance is not portable across the different processor architectures.

Example 5-14 shows the Streaming SIMD Extensions inlined assembly encoding.

Example 5-14. Streaming SIMD Extensions Using Inlined Assembly Encoding

```
void add(float *a, float *b, float *c)
{
  __asm {
    mov  eax, a
    mov  edx, b
    mov  ecx, c
    movaps xmm0, XMMWORD PTR [eax]
    addps  xmm0, XMMWORD PTR [edx]
    movaps XMMWORD PTR [ecx], xmm0
  }
}
```

5.3.1.2 Intrinsics

Intrinsics provide the access to the ISA functionality using C/C++ style coding instead of assembly language. Intel has defined three sets of intrinsic functions that are implemented in the Intel C++ Compiler to support the MMX technology, Streaming SIMD Extensions and Streaming SIMD Extensions 2. Four new C data types, representing 64-bit and 128-bit objects are used as the operands of these intrinsic functions. `__M64` is used for MMX integer SIMD, `__M128` is used for single-precision floating-point SIMD, `__M128I` is used for Streaming SIMD Extensions 2 integer SIMD, and `__M128D` is used for double precision floating-point SIMD. These types enable the programmer to choose the implementation of an algorithm directly, while allowing the compiler to perform register allocation and instruction sched-

uling where possible. The intrinsics are portable among all Intel architecture-based processors supported by a compiler.

The use of intrinsics allows you to obtain performance close to the levels achievable with assembly. The cost of writing and maintaining programs with intrinsics is considerably less. For a detailed description of the intrinsics and their use, refer to the Intel C++ Compiler documentation.

Example 5-15 shows the loop from Example 5-13 using intrinsics.

Example 5-15. Simple Four-Iteration Loop Coded with Intrinsics

```
#include <xmmintrin.h>
void add(float *a, float *b, float *c)
{
    __m128 t0, t1;
    t0 = _mm_load_ps(a);
    t1 = _mm_load_ps(b);
    t0 = _mm_add_ps(t0, t1);
    _mm_store_ps(c, t0);
}
```

The intrinsics map one-to-one with actual Streaming SIMD Extensions assembly code. The XMMINTRIN.H header file in which the prototypes for the intrinsics are defined is part of the Intel C++ Compiler included with the VTune Performance Enhancement Environment CD.

Intrinsics are also defined for the MMX technology ISA. These are based on the `__m64` data type to represent the contents of an mm register. You can specify values in bytes, short integers, 32-bit values, or as a 64-bit object.

The intrinsic data types, however, are not a basic ANSI C data type, and therefore you must observe the following usage restrictions:

- Use intrinsic data types only on the left-hand side of an assignment as a return value or as a parameter. You cannot use it with other arithmetic expressions (for example, "+", ">>").
- Use intrinsic data type objects in aggregates, such as unions to access the byte elements and structures; the address of an `__M64` object may be also used.
- Use intrinsic data type data only with the MMX technology intrinsics described in this guide.

For complete details of the hardware instructions, see the *Intel Architecture MMX Technology Programmer's Reference Manual*. For a description of data types, see the *Intel® 64 and IA-32 Architectures Software Developer's Manual*.

5.3.1.3 Classes

A set of C++ classes has been defined and available in Intel C++ Compiler to provide both a higher-level abstraction and more flexibility for programming with MMX technology, Streaming SIMD Extensions and Streaming SIMD Extensions 2. These classes provide an easy-to-use and flexible interface to the intrinsic functions, allowing developers to write more natural C++ code without worrying about which intrinsic or assembly language instruction to use for a given operation. Since the intrinsic functions underlie the implementation of these C++ classes, the performance of applications using this methodology can approach that of one using the intrinsics. Further details on the use of these classes can be found in the *Intel C++ Class Libraries for SIMD Operations User's Guide*, order number 693500.

Example 5-16 shows the C++ code using a vector class library. The example assumes the arrays passed to the routine are already aligned to 16-byte boundaries.

Example 5-16. C++ Code Using the Vector Classes

```
#include <fvec.h>
void add(float *a, float *b, float *c)
{
    F32vec4 *av=(F32vec4 *) a;
    F32vec4 *bv=(F32vec4 *) b;
    F32vec4 *cv=(F32vec4 *) c;
    *cv=*av + *bv;
}
```

Here, fvec.h is the class definition file and F32vec4 is the class representing an array of four floats. The “+” and “=” operators are overloaded so that the actual Streaming SIMD Extensions implementation in the previous example is abstracted out, or hidden, from the developer. Note how much more this resembles the original code, allowing for simpler and faster programming.

Again, the example is assuming the arrays, passed to the routine, are already aligned to 16-byte boundary.

5.3.1.4 Automatic Vectorization

The Intel C++ Compiler provides an optimization mechanism by which loops, such as in Example 5-13 can be automatically vectorized, or converted into Streaming SIMD Extensions code. The compiler uses similar techniques to those used by a programmer to identify whether a loop is suitable for conversion to SIMD. This involves determining whether the following might prevent vectorization:

- The layout of the loop and the data structures used.
- Dependencies amongst the data accesses in each iteration and across iterations.

Once the compiler has made such a determination, it can generate vectorized code for the loop, allowing the application to use the SIMD instructions.

The caveat to this is that only certain types of loops can be automatically vectorized, and in most cases user interaction with the compiler is needed to fully enable this.

Example 5-17 shows the code for automatic vectorization for the simple four-iteration loop (from Example 5-13).

Example 5-17. Automatic Vectorization for a Simple Loop

```
void add (float *restrict a,
         float *restrict b,
         float *restrict c)
{
    int i;
    for (i = 0; i < 4; i++) {
        c[i] = a[i] + b[i];
    }
}
```

Compile this code using the -QAX and -QRESTRICT switches of the Intel C++ Compiler, version 4.0 or later.

The RESTRICT qualifier in the argument list is necessary to let the compiler know that there are no other aliases to the memory to which the pointers point. In other words, the pointer for which it is used,

provides the only means of accessing the memory in question in the scope in which the pointers live. Without the restrict qualifier, the compiler will still vectorize this loop using runtime data dependence testing, where the generated code dynamically selects between sequential or vector execution of the loop, based on overlap of the parameters (See documentation for the Intel C++ Compiler). The restrict keyword avoids the associated overhead altogether.

See Intel C++ Compiler documentation for details.

5.4 STACK AND DATA ALIGNMENT

To get the most performance out of code written for SIMD technologies data should be formatted in memory according to the guidelines described in this section. Assembly code with unaligned accesses is a lot slower than an aligned access.

5.4.1 Alignment and Contiguity of Data Access Patterns

The 64-bit packed data types defined by MMX technology, and the 128-bit packed data types for Streaming SIMD Extensions and Streaming SIMD Extensions 2 create more potential for misaligned data accesses. The data access patterns of many algorithms are inherently misaligned when using MMX technology and Streaming SIMD Extensions. Several techniques for improving data access, such as padding, organizing data elements into arrays, etc. are described below. SSE3 provides a special-purpose instruction LDDQU that can avoid cache line splits is discussed in Section 6.7.2, "Increasing Bandwidth of Memory Fills and Video Fills."

5.4.1.1 Using Padding to Align Data

However, when accessing SIMD data using SIMD operations, access to data can be improved simply by a change in the declaration. For example, consider a declaration of a structure, which represents a point in space plus an attribute.

```
typedef struct {short x,y,z; char a} Point;
Point pt[N];
```

Assume we will be performing a number of computations on X, Y, Z in three of the four elements of a SIMD word; see Section 5.5.1, "Data Structure Layout," for an example. Even if the first element in array PT is aligned, the second element will start 7 bytes later and not be aligned (3 shorts at two bytes each plus a single byte = 7 bytes).

By adding the padding variable PAD, the structure is now 8 bytes, and if the first element is aligned to 8 bytes (64 bits), all following elements will also be aligned. The sample declaration follows:

```
typedef struct {short x,y,z; char a; char pad;} Point;
Point pt[N];
```

5.4.1.2 Using Arrays to Make Data Contiguous

In the following code,

```
for (i=0; i<N; i++) pt[i].y *= scale;
```

the second dimension Y needs to be multiplied by a scaling value. Here, the FOR loop accesses each Y dimension in the array PT thus disallowing the access to contiguous data. This can degrade the performance of the application by increasing cache misses, by poor utilization of each cache line that is fetched, and by increasing the chance for accesses which span multiple cache lines.

The following declaration allows you to vectorize the scaling operation and further improve the alignment of the data access patterns:

```
short ptx[N], pty[N], ptz[N];
for (i=0; i<N; i++) pty[i] *= scale;
```

With the SIMD technology, choice of data organization becomes more important and should be made carefully based on the operations that will be performed on the data. In some applications, traditional data arrangements may not lead to the maximum performance.

A simple example of this is an FIR filter. An FIR filter is effectively a vector dot product in the length of the number of coefficient taps.

Consider the following code:

```
(data [ j ] *coeff [0] + data [j+1]*coeff [1]+...+data [j+num of taps-1]*coeff [num of taps-1]),
```

If in the code above the filter operation of data element I is the vector dot product that begins at data element J, then the filter operation of data element I+1 begins at data element J+1.

Assuming you have a 64-bit aligned data vector and a 64-bit aligned coefficients vector, the filter operation on the first data element will be fully aligned. For the second data element, however, access to the data vector will be misaligned. For an example of how to avoid the misalignment problem in the FIR filter, refer to Intel application notes on Streaming SIMD Extensions and filters.

Duplication and padding of data structures can be used to avoid the problem of data accesses in algorithms which are inherently misaligned. Section 5.5.1, "Data Structure Layout," discusses trade-offs for organizing data structures.

NOTE

The duplication and padding technique overcomes the misalignment problem, thus avoiding the expensive penalty for misaligned data access, at the cost of increasing the data size. When developing your code, you should consider this tradeoff and use the option which gives the best performance.

5.4.2 Stack Alignment For 128-bit SIMD Technologies

For best performance, the Streaming SIMD Extensions and Streaming SIMD Extensions 2 require their memory operands to be aligned to 16-byte boundaries. Unaligned data can cause significant performance penalties compared to aligned data. However, the existing software conventions for IA-32 (STDCALL, CDECL, FASTCALL) as implemented in most compilers, do not provide any mechanism for ensuring that certain local data and certain parameters are 16-byte aligned. Therefore, Intel has defined a new set of IA-32 software conventions for alignment to support the new `__M128*` datatypes (`__M128`, `__M128D`, and `__M218I`). These meet the following conditions:

- Functions that use Streaming SIMD Extensions or Streaming SIMD Extensions 2 data need to provide a 16-byte aligned stack frame.
- `__M128*` parameters need to be aligned to 16-byte boundaries, possibly creating "holes" (due to padding) in the argument block.

The new conventions presented in this section as implemented by the Intel C++ Compiler can be used as a guideline for an assembly language code as well. In many cases, this section assumes the use of the `__M128*` data types, as defined by the Intel C++ Compiler, which represents an array of four 32-bit floats.

5.4.3 Data Alignment for MMX Technology

Many compilers enable alignment of variables using controls. This aligns variable bit lengths to the appropriate boundaries. If some of the variables are not appropriately aligned as specified, you can align them using the C algorithm in Example 5-18.

Example 5-18. C Algorithm for 64-bit Data Alignment

```
/* Make newp a pointer to a 64-bit aligned array of NUM_ELEMENTS 64-bit elements. */
double *p, *newp;
p = (double*)malloc (sizeof(double)*(NUM_ELEMENTS+1));
newp = (p+7) & (~0x7);
```

The algorithm in Example 5-18 aligns an array of 64-bit elements on a 64-bit boundary. The constant of 7 is derived from one less than the number of bytes in a 64-bit element, or 8-1. Aligning data in this manner avoids the significant performance penalties that can occur when an access crosses a cache line boundary.

Another way to improve data alignment is to copy the data into locations that are aligned on 64-bit boundaries. When the data is accessed frequently, this can provide a significant performance improvement.

5.4.4 Data Alignment for 128-bit data

Data must be 16-byte aligned when loading to and storing from the 128-bit XMM registers used by SSE/SSE2/SSE3/SSSE3. This must be done to avoid severe performance penalties and, at worst, execution faults.

There are MOVE instructions (and intrinsics) that allow unaligned data to be copied to and out of XMM registers when not using aligned data, but such operations are much slower than aligned accesses. If data is not 16-byte-aligned and the programmer or the compiler does not detect this and uses the aligned instructions, a fault occurs. So keep data 16-byte-aligned. Such alignment also works for MMX technology code, even though MMX technology only requires 8-byte alignment.

The following describes alignment techniques for Pentium 4 processor as implemented with the Intel C++ Compiler.

5.4.4.1 Compiler-Supported Alignment

The Intel C++ Compiler provides the following methods to ensure that the data is aligned.

Alignment by F32vec4 or __m128 Data Types

When the compiler detects F32VEC4 or __M128 data declarations or parameters, it forces alignment of the object to a 16-byte boundary for both global and local data, as well as parameters. If the declaration is within a function, the compiler also aligns the function's stack frame to ensure that local data and parameters are 16-byte-aligned. For details on the stack frame layout that the compiler generates for both debug and optimized ("release"-mode) compilations, refer to Intel's compiler documentation.

__declspec(align(16)) specifications

These can be placed before data declarations to force 16-byte alignment. This is useful for local or global data declarations that are assigned to 128-bit data types. The syntax for it is

```
__declspec(align(integer-constant))
```

where the INTEGER-CONSTANT is an integral power of two but no greater than 32. For example, the following increases the alignment to 16-bytes:

```
__declspec(align(16)) float buffer[400];
```

The variable BUFFER could then be used as if it contained 100 objects of type __M128 or F32VEC4. In the code below, the construction of the F32VEC4 object, X, will occur with aligned data.

```
void foo() {
    F32vec4 x = (__m128 *) buffer;
    ...
}
```

Without the declaration of __DECLSPEC(ALIGN(16)), a fault may occur.

Alignment by Using a UNION Structure

When feasible, a UNION can be used with 128-bit data types to allow the compiler to align the data structure by default. This is preferred to forcing alignment with __DECLSPEC(ALIGN(16)) because it exposes the true program intent to the compiler in that __M128 data is being used. For example:

```
union {
    float f[400];
    __m128 m[100];
} buffer;
```

Now, 16-byte alignment is used by default due to the `__M128` type in the UNION; it is not necessary to use `__DECLSPEC(ALIGN(16))` to force the result.

In C++ (but not in C) it is also possible to force the alignment of a CLASS/STRUCT/UNION type, as in the code that follows:

```
struct __declspec(align(16)) my_m128
{
    float f[4];
};
```

If the data in such a CLASS is going to be used with the Streaming SIMD Extensions or Streaming SIMD Extensions 2, it is preferable to use a UNION to make this explicit. In C++, an anonymous UNION can be used to make this more convenient:

```
class my_m128 {
    union {
        __m128 m;
        float f[4];
    };
};
```

Because the UNION is anonymous, the names, M and F, can be used as immediate member names of MY__M128. Note that `__DECLSPEC(ALIGN)` has no effect when applied to a CLASS, STRUCT, or UNION member in either C or C++.

Alignment by Using `__m64` or DOUBLE Data

In some cases, the compiler aligns routines with `__M64` or DOUBLE data to 16-bytes by default. The command-line switch, `-QSFALIGN16`, limits the compiler so that it only performs this alignment on routines that contain 128-bit data. The default behavior is to use `-QSFALIGN8`. This switch instructs the compiler to align routines with 8- or 16-byte data types to 16 bytes.

For more, see the Intel C++ Compiler documentation.

5.5 IMPROVING MEMORY UTILIZATION

Memory performance can be improved by rearranging data and algorithms for SSE, SSE2, and MMX technology intrinsics. Methods for improving memory performance involve working with the following:

- Data structure layout.
- Strip-mining for vectorization and memory utilization.
- Loop-blocking.

Using the cacheability instructions, prefetch and streaming store, also greatly enhance memory utilization. See also: Chapter 9, "Optimizing Cache Usage."

5.5.1 Data Structure Layout

For certain algorithms, like 3D transformations and lighting, there are two basic ways to arrange vertex data. The traditional method is the array of structures (AoS) arrangement, with a structure for each

vertex (Example 5-19). However this method does not take full advantage of SIMD technology capabilities.

Example 5-19. AoS Data Structure

```
typedef struct{
    float x,y,z;
    int a,b,c;
    ...
} Vertex;
Vertex Vertices[NumOfVertices];
```

The best processing method for code using SIMD technology is to arrange the data in an array for each coordinate (Example 5-20). This data arrangement is called structure of arrays (SoA).

Example 5-20. SoA Data Structure

```
typedef struct{
    float x[NumOfVertices];
    float y[NumOfVertices];
    float z[NumOfVertices];
    int a[NumOfVertices];
    int b[NumOfVertices];
    int c[NumOfVertices];
    ...
} VerticesList;
VerticesList Vertices;
```

There are two options for computing data in AoS format: perform operation on the data as it stands in AoS format, or re-arrange it (swizzle it) into SoA format dynamically. See Example 5-21 for code samples of each option based on a dot-product computation.

Example 5-21. AoS and SoA Code Samples

```
; The dot product of an array of vectors (Array) and a fixed vector (Fixed) is a
; common operation in 3D lighting operations, where Array = (x0,y0,z0),(x1,y1,z1),...
; and Fixed = (xF,yF,zF)
; A dot product is defined as the scalar quantity d0 = x0*xF + y0*yF + z0*zF.
;
; AoS code
; All values marked DC are "don't-care."

; In the AOS model, the vertices are stored in the xyz format
movaps xmm0, Array      ; xmm0 = DC, x0, y0, z0
movaps xmm1, Fixed      ; xmm1 = DC, xF, yF, zF
mulps  xmm0, xmm1      ; xmm0 = DC, x0*xF, y0*yF, z0*zF
movhps xmm, xmm0       ; xmm = DC, DC, DC, x0*xF

addps  xmm1, xmm0      ; xmm0 = DC, DC, DC,
                        ; x0*xF+z0*zF
movaps xmm2, xmm1
shufps xmm2, xmm2, 55h ; xmm2 = DC, DC, DC, y0*yF
addps  xmm2, xmm1      ; xmm1 = DC, DC, DC,
                        ; x0*xF+y0*yF+z0*zF
```

Example 5-21. AoS and SoA Code Samples (Contd.)

```

; SoA code
; X = x0,x1,x2,x3
; Y = y0,y1,y2,y3
; Z = z0,z1,z2,z3
; A = xF,xF,xF,xF
; B = yF,yF,yF,yF
; C = zF,zF,zF,zF

movaps xmm0, X      ; xmm0 = x0,x1,x2,x3
movaps xmm1, Y      ; xmm1 = y0,y1,y2,y3
movaps xmm2, Z      ; xmm2 = z0,z1,z2,z3
mulps  xmm0, A      ; xmm0 = x0*xF, x1*xF, x2*xF, x3*xF
mulps  xmm1, B      ; xmm1 = y0*yF, y1*yF, y2*yF, y3*yF
mulps  xmm2, C      ; xmm2 = z0*zF, z1*zF, z2*zF, z3*zF
addps  xmm0, xmm1
addps  xmm0, xmm2   ; xmm0 = (x0*xF+y0*yF+z0*zF), ...

```

Performing SIMD operations on the original AoS format can require more calculations and some operations do not take advantage of all SIMD elements available. Therefore, this option is generally less efficient.

The recommended way for computing data in AoS format is to swizzle each set of elements to SoA format before processing it using SIMD technologies. Swizzling can either be done dynamically during program execution or statically when the data structures are generated. See Chapter 6 and Chapter 7 for examples. Performing the swizzle dynamically is usually better than using AoS, but can be somewhat inefficient because there are extra instructions during computation. Performing the swizzle statically, when data structures are being laid out, is best as there is no runtime overhead.

As mentioned earlier, the SoA arrangement allows more efficient use of the parallelism of SIMD technologies because the data is ready for computation in a more optimal vertical manner: multiplying components X0,X1,X2,X3 by XF,XF,XF,XF using 4 SIMD execution slots to produce 4 unique results. In contrast, computing directly on AoS data can lead to horizontal operations that consume SIMD execution slots but produce only a single scalar result (as shown by the many “don’t-care” (DC) slots in Example 5-21).

Use of the SoA format for data structures can lead to more efficient use of caches and bandwidth. When the elements of the structure are not accessed with equal frequency, such as when element x, y, z are accessed ten times more often than the other entries, then SoA saves memory and prevents fetching unnecessary data items a, b, and c.

Example 5-22. Hybrid SoA Data Structure

```

NumOfGroups = NumOfVertices/SIMDwidth
typedef struct{
    float x[SIMDwidth];
    float y[SIMDwidth];
    float z[SIMDwidth];
} VerticesCoordList;
typedef struct{
    int a[SIMDwidth];
    int b[SIMDwidth];
    int c[SIMDwidth];
    ...
} VerticesColorList;
VerticesCoordList VerticesCoord[NumOfGroups];
VerticesColorList VerticesColor[NumOfGroups];

```

Note that SoA can have the disadvantage of requiring more independent memory stream references. A computation that uses arrays X, Y, and Z (see Example 5-20) would require three separate data streams. This can require the use of more prefetches, additional address generation calculations, as well as having a greater impact on DRAM page access efficiency.

There is an alternative: a hybrid SoA approach blends the two alternatives (see Example 5-22). In this case, only 2 separate address streams are generated and referenced: one contains XXXX, YYYY, ZZZZ, ZZZZ,... and the other AAAA, BBBB, CCCC, AAAA, DDDD,... . The approach prevents fetching unnecessary data, assuming the variables X, Y, Z are always used together; whereas the variables A, B, C would also be used together, but not at the same time as X, Y, Z.

The hybrid SoA approach ensures:

- Data is organized to enable more efficient vertical SIMD computation.
- Simpler/less address generation than AoS.
- Fewer streams, which reduces DRAM page misses.
- Use of fewer prefetches, due to fewer streams.
- Efficient cache line packing of data elements that are used concurrently.

With the advent of the SIMD technologies, the choice of data organization becomes more important and should be carefully based on the operations to be performed on the data. This will become increasingly important in the Pentium 4 processor and future processors. In some applications, traditional data arrangements may not lead to the maximum performance. Application developers are encouraged to explore different data arrangements and data segmentation policies for efficient computation. This may mean using a combination of AoS, SoA, and Hybrid SoA in a given application.

5.5.2 Strip-Mining

Strip-mining, also known as loop sectioning, is a loop transformation technique for enabling SIMD-encodings of loops, as well as providing a means of improving memory performance. First introduced for vectorizers, this technique consists of the generation of code when each vector operation is done for a size less than or equal to the maximum vector length on a given vector machine. By fragmenting a large loop into smaller segments or strips, this technique transforms the loop structure by:

- Increasing the temporal and spatial locality in the data cache if the data are reusable in different passes of an algorithm.
- Reducing the number of iterations of the loop by a factor of the length of each “vector,” or number of operations being performed per SIMD operation. In the case of Streaming SIMD Extensions, this vector or strip-length is reduced by 4 times: four floating-point data items per single Streaming SIMD Extensions single-precision floating-point SIMD operation are processed. Consider Example 5-23.

Example 5-23. Pseudo-code Before Strip Mining

```
typedef struct _VERTEX {
    float x, y, z, nx, ny, nz, u, v;
} Vertex_rec;

main()
{
    Vertex_rec v[Num];
    ....
    for (i=0; i<Num; i++) {
        Transform(v[i]);
    }
}
```

Example 5-23. Pseudo-code Before Strip Mining (Contd.)

```

    for (i=0; i<Num; i++) {
        Lighting(v[i]);
    }
    ....
}

```

The main loop consists of two functions: transformation and lighting. For each object, the main loop calls a transformation routine to update some data, then calls the lighting routine to further work on the data. If the size of array $V[\text{NUM}]$ is larger than the cache, then the coordinates for $V[I]$ that were cached during $\text{TRANSFORM}(V[I])$ will be evicted from the cache by the time we do $\text{LIGHTING}(V[I])$. This means that $V[I]$ will have to be fetched from main memory a second time, reducing performance.

In Example 5-24, the computation has been strip-mined to a size STRIP_SIZE . The value STRIP_SIZE is chosen such that STRIP_SIZE elements of array $V[\text{NUM}]$ fit into the cache hierarchy. By doing this, a given element $V[I]$ brought into the cache by $\text{TRANSFORM}(V[I])$ will still be in the cache when we perform $\text{LIGHTING}(V[I])$, and thus improve performance over the non-strip-mined code.

Example 5-24. Strip Mined Code

```

MAIN()
{
    Vertex_rec v[Num];
    ....
    for (i=0; i < Num; i+=strip_size) {
        FOR (J=I; J < MIN(NUM, I+STRIP_SIZE); J++) {
            TRANSFORM(V[J]);
        }
        FOR (J=I; J < MIN(NUM, I+STRIP_SIZE); J++) {
            LIGHTING(V[J]);
        }
    }
}

```

5.5.3 Loop Blocking

Loop blocking is another useful technique for memory performance optimization. The main purpose of loop blocking is also to eliminate as many cache misses as possible. This technique transforms the memory domain of a given problem into smaller chunks rather than sequentially traversing through the entire memory domain. Each chunk should be small enough to fit all the data for a given computation into the cache, thereby maximizing data reuse. In fact, one can treat loop blocking as strip mining in two or more dimensions. Consider the code in Example 5-23 and access pattern in Figure 5-5. The two-dimensional array A is referenced in the J (column) direction and then referenced in the I (row) direction (column-major order); whereas array B is referenced in the opposite manner (row-major order). Assume the memory layout is in column-major order; therefore, the access strides of array A and B for the code in Example 5-25 would be 1 and MAX , respectively.

Example 5-25. Loop Blocking

```

A. Original Loop
float A[MAX, MAX], B[MAX, MAX]
for (i=0; i < MAX; i++) {
    for (j=0; j < MAX; j++) {
        A[i,j] = A[i,j] + B[j, i];
    }
}

```

Example 5-25. Loop Blocking (Contd.)

```

B. Transformed Loop after Blocking
float A[MAX, MAX], B[MAX, MAX];
for (i=0; i < MAX; i+=block_size) {
    for (j=0; j < MAX; j+=block_size) {
        for (ii=i; ii<i+block_size; ii++) {
            for (jj=j; jj<j+block_size; jj++) {
                A[ii,jj] = A[ii,jj] + B[jj, ii];
            }
        }
    }
}

```

For the first iteration of the inner loop, each access to array B will generate a cache miss. If the size of one row of array A, that is, $A[2, 0:MAX-1]$, is large enough, by the time the second iteration starts, each access to array B will always generate a cache miss. For instance, on the first iteration, the cache line containing $B[0, 0:7]$ will be brought in when $B[0,0]$ is referenced because the float type variable is four bytes and each cache line is 32 bytes. Due to the limitation of cache capacity, this line will be evicted due to conflict misses before the inner loop reaches the end. For the next iteration of the outer loop, another cache miss will be generated while referencing $B[0, 1]$. In this manner, a cache miss occurs when each element of array B is referenced, that is, there is no data reuse in the cache at all for array B.

This situation can be avoided if the loop is blocked with respect to the cache size. In Figure 5-5, a `BLOCK_SIZE` is selected as the loop blocking factor. Suppose that `BLOCK_SIZE` is 8, then the blocked chunk of each array will be eight cache lines (32 bytes each). In the first iteration of the inner loop, $A[0, 0:7]$ and $B[0, 0:7]$ will be brought into the cache. $B[0, 0:7]$ will be completely consumed by the first iteration of the outer loop. Consequently, $B[0, 0:7]$ will only experience one cache miss after applying loop blocking optimization in lieu of eight misses for the original algorithm. As illustrated in Figure 5-5, arrays A and B are blocked into smaller rectangular chunks so that the total size of two blocked A and B chunks is smaller than the cache size. This allows maximum data reuse.

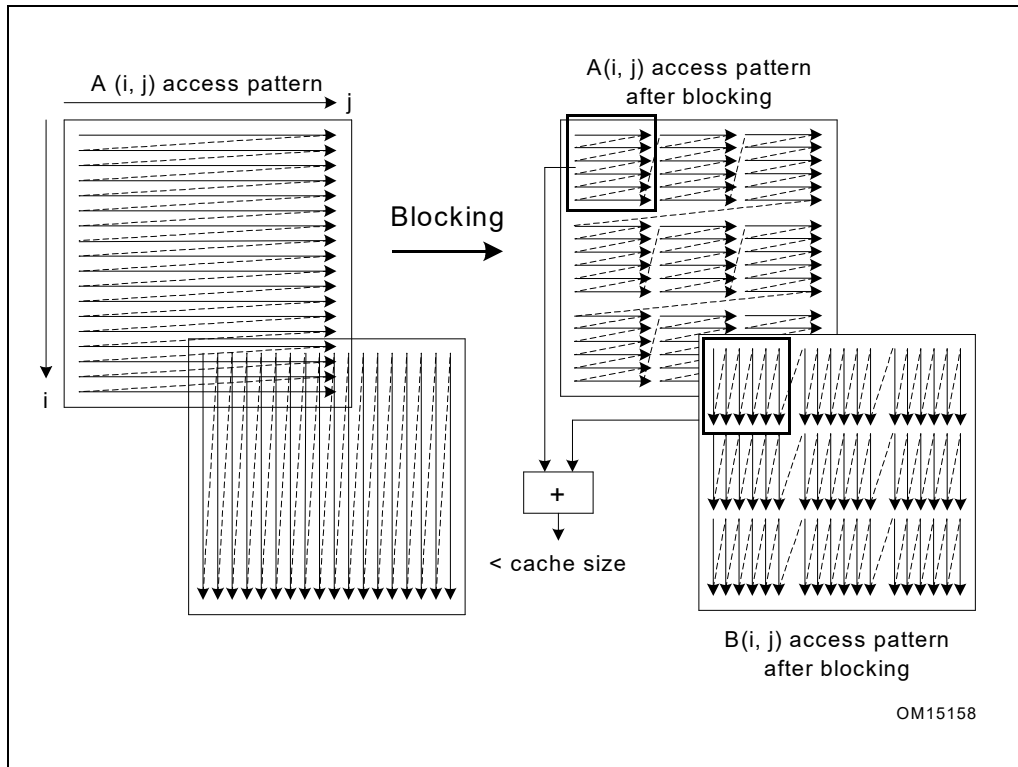

Figure 5-5. Loop Blocking Access Pattern

As one can see, all the redundant cache misses can be eliminated by applying this loop blocking technique. If MAX is huge, loop blocking can also help reduce the penalty from DTLB (data translation look-aside buffer) misses. In addition to improving the cache/memory performance, this optimization technique also saves external bus bandwidth.

5.6 INSTRUCTION SELECTION

The following section gives some guidelines for choosing instructions to complete a task.

One barrier to SIMD computation can be the existence of data-dependent branches. Conditional moves can be used to eliminate data-dependent branches. Conditional moves can be emulated in SIMD computation by using masked compares and logicals, as shown in Example 5-26. SSE4.1 provides packed blend instruction that can vectorize data-dependent branches in a loop.

Example 5-26. Emulation of Conditional Moves

```
High-level code:
__declspec(align(16)) short A[MAX_ELEMENT], B[MAX_ELEMENT], C[MAX_ELEMENT], D[MAX_ELEMENT],
E[MAX_ELEMENT];

for (i=0; i<MAX_ELEMENT; i++) {
    if (A[i] > B[i]) {
        C[i] = D[i];
    } else {
        C[i] = E[i];
    }
}
```

Example 5-26. Emulation of Conditional Moves (Contd.)

```

}
MMX assembly code processes 4 short values per iteration:
    xor     eax, eax

top_of_loop:
    movq   mm0, [A + eax]
    pcmptw xmm0, [B + eax]; Create compare mask
    movq   mm1, [D + eax]
    pand   mm1, mm0; Drop elements where A<B
    pandn  mm0, [E + eax]; Drop elements where A>B

    por    mm0, mm1; Create single word
    movq   [C + eax], mm0
    add    eax, 8
    cmp    eax, MAX_ELEMENT*2
    jle    top_of_loop

SSE4.1 assembly processes 8 short values per iteration:
    xor     eax, eax

top_of_loop:
    movdqq xmm0, [A + eax]
    pcmptw xmm0, [B + eax]; Create compare mask
    movdqa xmm1, [E + eax]
    pblendv xmm1, [D + eax], xmm0;
    movdqa [C + eax], xmm1;
    add    eax, 16
    cmp    eax, MAX_ELEMENT*2
    jle    top_of_loop

```

If there are multiple consumers of an instance of a register, group the consumers together as closely as possible. However, the consumers should not be scheduled near the producer.

5.7 TUNING THE FINAL APPLICATION

The best way to tune your application once it is functioning correctly is to use a profiler that measures the application while it is running on a system. Intel VTune Amplifier XE can help you determine where to make changes in your application to improve performance. Using Intel VTune Amplifier XE can help you with various phases required for optimized performance. See Appendix A.3.1, “Intel® VTune™ Amplifier XE,” for details. After every effort to optimize, you should check the performance gains to see where you are making your major optimization gains.

CHAPTER 6

OPTIMIZING FOR SIMD INTEGER APPLICATIONS

SIMD integer instructions provide performance improvements in applications that are integer-intensive and can take advantage of SIMD architecture.

Guidelines in this chapter for using SIMD integer instructions (in addition to those described in Chapter 3) may be used to develop fast and efficient code that scales across processor generations.

The collection of 64-bit and 128-bit SIMD integer instructions supported by MMX technology, SSE, SSE2, SSE3, SSSE3, SSE4.1, and PCMPEQQ in SSE4.2 are referred to as SIMD integer instructions.

Code sequences in this chapter demonstrates the use of basic 64-bit SIMD integer instructions and more efficient 128-bit SIMD integer instructions.

Processors based on Intel Core microarchitecture support MMX, SSE, SSE2, SSE3, and SSSE3. Processors based on Enhanced Intel Core microarchitecture support SSE4.1 and all previous generations of SIMD integer instructions. Processors based on Nehalem microarchitecture support MMX, SSE, SSE2, SSE3, SSSE3, SSE4.1 and SSE4.2.

Single-instruction, multiple-data techniques can be applied to text/string processing, lexing and parser applications. SIMD programming in string/text processing and lexing applications often require sophisticated techniques beyond those commonly used in SIMD integer programming. This is covered in Chapter 14, "SSE4.2 and SIMD Programming For Text-Processing/Lexing/Parsing."

Execution of 128-bit SIMD integer instructions in Intel Core microarchitecture and Enhanced Intel Core microarchitecture are substantially more efficient than on previous microarchitectures. Thus newer SIMD capabilities introduced in SSE4.1 operate on 128-bit operands and do not introduce equivalent 64-bit SIMD capabilities. Conversion from 64-bit SIMD integer code to 128-bit SIMD integer code is highly recommended.

This chapter contains examples that will help you to get started with coding your application. The goal is to provide simple, low-level operations that are frequently used. The examples use a minimum number of instructions necessary to achieve best performance on the current generation of Intel 64 and IA-32 processors.

Each example includes a short description, sample code, and notes if necessary. These examples do not address scheduling as it is assumed the examples will be incorporated in longer code sequences.

For planning considerations of using the SIMD integer instructions, refer to Section 5.1.3.

6.1 GENERAL RULES ON SIMD INTEGER CODE

General rules and suggestions are:

- Do not intermix 64-bit SIMD integer instructions with x87 floating-point instructions. See Section 6.2, "Using SIMD Integer with x87 Floating-point." Note that all SIMD integer instructions can be intermixed without penalty.
- Favor 128-bit SIMD integer code over 64-bit SIMD integer code. On microarchitectures prior to Intel Core microarchitecture, most 128-bit SIMD instructions have two-cycle throughput restrictions due to the underlying 64-bit data path in the execution engine. Intel Core microarchitecture executes most SIMD instructions (except shuffle, pack, unpack operations) with one-cycle throughput and provides three ports to execute multiple SIMD instructions in parallel. Enhanced Intel Core microarchitecture speeds up 128-bit shuffle, pack, unpack operations with 1 cycle throughput.
- When writing SIMD code that works for both integer and floating-point data, use the subset of SIMD convert instructions or load/store instructions to ensure that the input operands in XMM registers contain data types that are properly defined to match the instruction.

Code sequences containing cross-typed usage produce the same result across different implementations but incur a significant performance penalty. Using SSE/SSE2/SSE3/SSSE3/SSE4.1 instructions to operate on type-mismatched SIMD data in the XMM register is strongly discouraged.

- Use the optimization rules and guidelines described in Chapter 3 and Chapter 5.
- Take advantage of hardware prefetcher where possible. Use the PREFETCH instruction only when data access patterns are irregular and prefetch distance can be pre-determined. See Chapter 9, “Optimizing Cache Usage.”
- Emulate conditional moves by using blend, masked compares and logicals instead of using conditional branches.

6.2 USING SIMD INTEGER WITH X87 FLOATING-POINT

All 64-bit SIMD integer instructions use MMX registers, which share register state with the x87 floating-point stack. Because of this sharing, certain rules and considerations apply. Instructions using MMX registers cannot be freely intermixed with x87 floating-point registers. Take care when switching between 64-bit SIMD integer instructions and x87 floating-point instructions to ensure functional correctness. See Section 6.2.1.

Both Section 6.2.1 and Section 6.2.2 apply only to software that employs MMX instructions. As noted before, 128-bit SIMD integer instructions should be favored to replace MMX code and achieve higher performance. That also obviates the need to use EMMS, and the performance penalty of using EMMS when intermixing MMX and X87 instructions.

For performance considerations, there is no penalty of intermixing SIMD floating-point operations and 128-bit SIMD integer operations and x87 floating-point operations.

6.2.1 Using the EMMS Instruction

When generating 64-bit SIMD integer code, keep in mind that the eight MMX registers are aliased to x87 floating-point registers. Switching from MMX instructions to x87 floating-point instructions incurs a finite delay, so it is the best to minimize switching between these instruction types. But when switching, the EMMS instruction provides an efficient means to clear the x87 stack so that subsequent x87 code can operate properly.

As soon as an instruction makes reference to an MMX register, all valid bits in the x87 floating-point tag word are set, which implies that all x87 registers contain valid values. In order for software to operate correctly, the x87 floating-point stack should be emptied when starting a series of x87 floating-point calculations after operating on the MMX registers.

Using EMMS clears all valid bits, effectively emptying the x87 floating-point stack and making it ready for new x87 floating-point operations. The EMMS instruction ensures a clean transition between using operations on the MMX registers and using operations on the x87 floating-point stack. On the Pentium 4 processor, there is a finite overhead for using the EMMS instruction.

Failure to use the EMMS instruction (or the `_MM_EMPTY()` intrinsic) between operations on the MMX registers and x87 floating-point registers may lead to unexpected results.

NOTE

Failure to reset the tag word for FP instructions after using an MMX instruction can result in faulty execution or poor performance.

6.2.2 Guidelines for Using EMMS Instruction

When developing code with both x87 floating-point and 64-bit SIMD integer instructions, follow these steps:

1. Always call the EMMS instruction at the end of 64-bit SIMD integer code when the code transitions to x87 floating-point code.
2. Insert the EMMS instruction at the end of all 64-bit SIMD integer code segments to avoid an x87 floating-point stack overflow exception when an x87 floating-point instruction is executed.

When writing an application that uses both floating-point and 64-bit SIMD integer instructions, use the following guidelines to help you determine when to use EMMS:

- **If next instruction is x87 FP** — Use `_MM_EMPTY()` after a 64-bit SIMD integer instruction if the next instruction is an X87 FP instruction; for example, before doing calculations on floats, doubles or long doubles.
- **Don't empty when already empty** — If the next instruction uses an MMX register, `_MM_EMPTY()` incurs a cost with no benefit.
- **Group Instructions** — Try to partition regions that use X87 FP instructions from those that use 64-bit SIMD integer instructions. This eliminates the need for an EMMS instruction within the body of a critical loop.
- **Runtime initialization** — Use `_MM_EMPTY()` during runtime initialization of `__M64` and X87 FP data types. This ensures resetting the register between data type transitions. See Example 6-1 for coding usage.

Example 6-1. Resetting Register Between `__m64` and FP Data Types Code

Incorrect Usage	Correct Usage
<code>__m64 x = _m_padd(y, z); float f = init();</code>	<code>__m64 x = _m_padd(y, z); float f = (_mm_empty(), init());</code>

You must be aware that your code generates an MMX instruction, which uses MMX registers with the Intel C++ Compiler, in the following situations:

- when using a 64-bit SIMD integer intrinsic from MMX technology, SSE/SSE2/SSSE3
- when using a 64-bit SIMD integer instruction from MMX technology, SSE/SSE2/SSSE3 through inline assembly
- when referencing the `__M64` data type variable

Additional information on the x87 floating-point programming model can be found in the *Intel® 64 and IA-32 Architectures Software Developer's Manual, Volume 1*. For more on EMMS, visit <http://developer.intel.com>.

6.3 DATA ALIGNMENT

Make sure that 64-bit SIMD integer data is 8-byte aligned and that 128-bit SIMD integer data is 16-byte aligned. Referencing unaligned 64-bit SIMD integer data can incur a performance penalty due to accesses that span 2 cache lines. Referencing unaligned 128-bit SIMD integer data results in an exception unless the `MOVDQU` (move double-quadword unaligned) instruction is used. Using the `MOVDQU` instruction on unaligned data can result in lower performance than using 16-byte aligned references. Refer to Section 5.4, "Stack and Data Alignment," for more information.

Loading 16 bytes of SIMD data efficiently requires data alignment on 16-byte boundaries. `SSSE3` provides the `PALIGNR` instruction. It reduces overhead in situations that requires software to processing data elements from non-aligned address. The `PALIGNR` instruction is most valuable when loading or storing unaligned data with the address shifts by a few bytes. You can replace a set of unaligned loads with aligned loads followed by using `PALIGNR` instructions and simple register to register copies.

Using PALIGNRs to replace unaligned loads improves performance by eliminating cache line splits and other penalties. In routines like MEMCPY(), PALIGNR can boost the performance of misaligned cases. Example 6-2 shows a situation that benefits by using PALIGNR.

Example 6-2. FIR Processing Example in C language Code

```
void FIR(float *in, float *out, float *coeff, int count)
{int i;
  for ( i=0; i<count - TAP; i++)
  {   float sum = 0;
      for ( j=0; j<TAP; j++)
      {   sum += in[j]*coeff[j];
          *out++ = sum;
          in++;
      }
  }
}
```

Example 6-3 compares an optimal SSE2 sequence of the FIR loop and an equivalent SSSE3 implementation. Both implementations unroll 4 iteration of the FIR inner loop to enable SIMD coding techniques. The SSE2 code can not avoid experiencing cache line split once every four iterations. PALIGNR allows the SSSE3 code to avoid the delays associated with cache line splits.

Example 6-3. SSE2 and SSSE3 Implementation of FIR Processing Code

Optimized for SSE2	Optimized for SSSE3
<pre>pxor xmm0, xmm0 xor ecx, ecx mov eax, dword ptr[input] mov ebx, dword ptr[coeff4]</pre>	<pre>pxor xmm0, xmm0 xor ecx, ecx mov eax, dword ptr[input] mov ebx, dword ptr[coeff4]</pre>
<pre>inner_loop: movaps xmm1, xmmword ptr[eax+ecx] mulps xmm1, xmmword ptr[ebx+4*ecx] addps xmm0, xmm1</pre>	<pre>inner_loop: movaps xmm1, xmmword ptr[eax+ecx] movaps xmm3, xmm1 mulps xmm1, xmmword ptr[ebx+4*ecx] addps xmm0, xmm1</pre>
<pre>movups xmm1, xmmword ptr[eax+ecx+4] mulps xmm1, xmmword ptr[ebx+4*ecx+16] addps xmm0, xmm1</pre>	<pre>movaps xmm2, xmmword ptr[eax+ecx+16] movaps xmm1, xmm2 palignr xmm2, xmm3, 4 mulps xmm2, xmmword ptr[ebx+4*ecx+16] addps xmm0, xmm2</pre>
<pre>movups xmm1, xmmword ptr[eax+ecx+8] mulps xmm1, xmmword ptr[ebx+4*ecx+32] addps xmm0, xmm1</pre>	<pre>movaps xmm2, xmm1 palignr xmm2, xmm3, 8 mulps xmm2, xmmword ptr[ebx+4*ecx+32] addps xmm0, xmm2</pre>
<pre>movups xmm1, xmmword ptr[eax+ecx+12] mulps xmm1, xmmword ptr[ebx+4*ecx+48] addps xmm0, xmm1</pre>	<pre>movaps xmm2, xmm1 palignr xmm2, xmm3, 12 mulps xmm2, xmmword ptr[ebx+4*ecx+48] addps xmm0, xmm2</pre>
<pre>add ecx, 16 cmp ecx, 4*TAP jl inner_loop</pre>	<pre>add ecx, 16 cmp ecx, 4*TAP jl inner_loop</pre>
<pre>mov eax, dword ptr[output] movaps xmmword ptr[eax], xmm0</pre>	<pre>mov eax, dword ptr[output] movaps xmmword ptr[eax], xmm0</pre>

6.4 DATA MOVEMENT CODING TECHNIQUES

In general, better performance can be achieved if data is pre-arranged for SIMD computation (see Section 5.5, “Improving Memory Utilization”). This may not always be possible.

This section covers techniques for gathering and arranging data for more efficient SIMD computation.

6.4.1 Unsigned Unpack

MMX technology provides several instructions that are used to pack and unpack data in the MMX registers. SSE2 extends these instructions so that they operate on 128-bit source and destinations.

The unpack instructions can be used to zero-extend an unsigned number. Example 6-4 assumes the source is a packed-word (16-bit) data type.

Example 6-4. Zero Extend 16-bit Values into 32 Bits Using Unsigned Unpack Instructions Code

```

; Input:
;           XMM0      8 16-bit values in source
;           XMM7 0    a local variable can be used
;                   instead of the register XMM7 if
;                   desired.
;
; Output:
;           XMM0      four zero-extended 32-bit
;                   doublewords from four low-end
;                   words
;           XMM1      four zero-extended 32-bit
;                   doublewords from four high-end
;                   words
;
movdqa    xmm1, xmm0 ; copy source
punpcklwd xmm0, xmm7 ; unpack the 4 low-end words
;                   ; into 4 32-bit doubleword
punpckhwd xmm1, xmm7 ; unpack the 4 high-end words
;                   ; into 4 32-bit doublewords

```

6.4.2 Signed Unpack

Signed numbers should be sign-extended when unpacking values. This is similar to the zero-extend shown above, except that the PSRAD instruction (packed shift right arithmetic) is used to sign extend the values.

Example 6-5 assumes the source is a packed-word (16-bit) data type.

Example 6-5. Signed Unpack Code

```

Input:
;           XMM0      source value
; Output:
;           XMM0      four sign-extended 32-bit doublewords
;                   from four low-end words
;           XMM1      four sign-extended 32-bit doublewords
;                   from four high-end words
;

```

Example 6-5. Signed Unpack Code (Contd.)

```

movdqa    xmm1, xmm0 ; copy source
punpcklwd xmm0, xmm0 ; unpack four low end words of the source
                ; into the upper 16 bits of each doubleword
                ; in the destination
punpckhwd xmm1, xmm1 ; unpack 4 high-end words of the source
                ; into the upper 16 bits of each doubleword
                ; in the destination

psrad     xmm0, 16    ; sign-extend the 4 low-end words of the source
                ; into four 32-bit signed doublewords
psrad     xmm1, 16    ; sign-extend the 4 high-end words of the
                ; source into four 32-bit signed doublewords

```

6.4.3 Interleaved Pack with Saturation

Pack instructions pack two values into a destination register in a predetermined order. PACKSSDW saturates two signed doublewords from a source operand and two signed doublewords from a destination operand into four signed words; and it packs the four signed words into a destination register. See Figure 6-1.

SSE2 extends PACKSSDW so that it saturates four signed doublewords from a source operand and four signed doublewords from a destination operand into eight signed words; the eight signed words are packed into the destination.

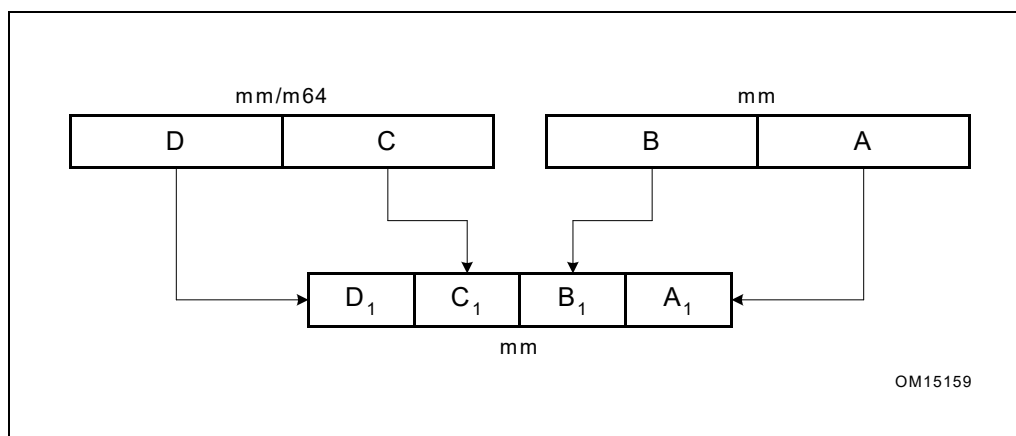

Figure 6-1. PACKSSDW mm, mm/mm64 Instruction

Figure 6-2 illustrates where two pairs of values are interleaved in a destination register; Example 6-6 shows MMX code that accomplishes the operation.

Two signed doublewords are used as source operands and the result is interleaved signed words. The sequence in Example 6-6 can be extended in SSE2 to interleave eight signed words using XMM registers.

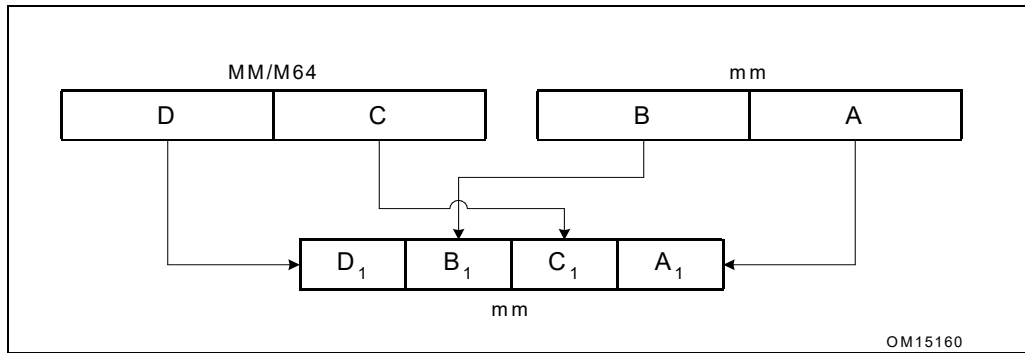

Figure 6-2. Interleaved Pack with Saturation

Example 6-6. Interleaved Pack with Saturation Code

```

; Input:
;   MM0   signed source1 value
;   MM1   signed source2 value
; Output:
;   MM0   the first and third words contain the
;         signed-saturated doublewords from MM0,
;         the second and fourth words contain
;         signed-saturated doublewords from MM1
;
packssdw  mm0, mm0 ; pack and sign saturate
packssdw  mm1, mm1 ; pack and sign saturate
punpcklwd mm0, mm1 ; interleave the low-end 16-bit
;               ; values of the operands

```

Pack instructions always assume that source operands are signed numbers. The result in the destination register is always defined by the pack instruction that performs the operation. For example, `PACKSSDW` packs each of two signed 32-bit values of two sources into four saturated 16-bit signed values in a destination register. `PACKUSWB`, on the other hand, packs the four signed 16-bit values of two sources into eight saturated eight-bit unsigned values in the destination.

6.4.4 Interleaved Pack without Saturation

Example 6-7 is similar to Example 6-6 except that the resulting words are not saturated. In addition, in order to protect against overflow, only the low order 16 bits of each doubleword are used. Again, Example 6-7 can be extended in SSE2 to accomplish interleaving eight words without saturation.

Example 6-7. Interleaved Pack without Saturation Code

```

; Input:
;   MM0   signed source value
;   MM1   signed source value
; Output:
;   MM0   the first and third words contain the
;         low 16-bits of the doublewords in MM0,
;         the second and fourth words contain the
;         low 16-bits of the doublewords in MM1

```

Example 6-7. Interleaved Pack without Saturation Code (Contd.)

```

pslld  mm1, 16    ; shift the 16 LSB from each of the
                  ; doubleword values to the 16 MSB
                  ; position
pand   mm0, {0,fff,0,fff}
                  ; mask to zero the 16 MSB
                  ; of each doubleword value
por    mm0, mm1   ; merge the two operands

```

6.4.5 Non-Interleaved Unpack

Unpack instructions perform an interleave merge of the data elements of the destination and source operands into the destination register.

The following example merges the two operands into destination registers without interleaving. For example, take two adjacent elements of a packed-word data type in SOURCE1 and place this value in the low 32 bits of the results. Then take two adjacent elements of a packed-word data type in SOURCE2 and place this value in the high 32 bits of the results. One of the destination registers will have the combination illustrated in Figure 6-3.

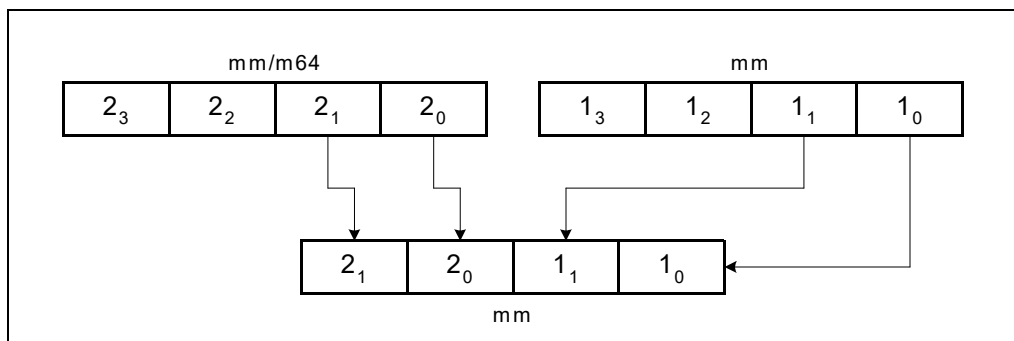

Figure 6-3. Result of Non-Interleaved Unpack Low in MM0

The other destination register will contain the opposite combination illustrated in Figure 6-4.

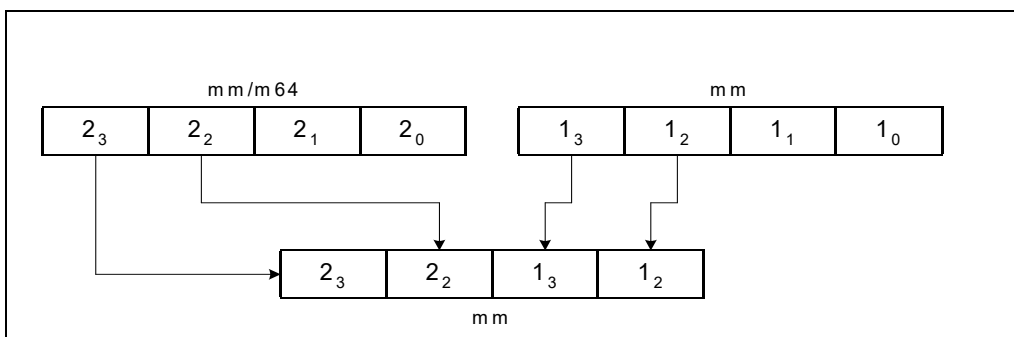

Figure 6-4. Result of Non-Interleaved Unpack High in MM1

Code in the Example 6-8 unpacks two packed-word sources in a non-interleaved way. The goal is to use the instruction which unpacks doublewords to a quadword, instead of using the instruction which unpacks words to doublewords.

Example 6-8. Unpacking Two Packed-word Sources in Non-interleaved Way Code

```

; Input:
;           MM0           packed-word source value
;           MM1           packed-word source value
; Output:
;           MM0           contains the two low-end words of the
;                           original sources, non-interleaved
;           MM2           contains the two high end words of the
;                           original sources, non-interleaved.
movq      mm2, mm0      ; copy source1
punpckldq mm0, mm1      ; replace the two high-end words of MM0 with
;                           two low-end words of MM1;
;                           leave the two low-end words of MM0 in place
punpckhdq mm2, mm1      ; move two high-end words of MM2 to the two low-end
;                           words of MM2; place the two high-end words of
;                           MM1 in two high-end words of MM2

```

6.4.6 Extract Data Element

The PEXTRW instruction in SSE takes the word in the designated MMX register selected by the two least significant bits of the immediate value and moves it to the lower half of a 32-bit integer register. See Figure 6-5 and Example 6-9.

With SSE2, PEXTRW can extract a word from an XMM register to the lower 16 bits of an integer register. SSE4.1 provides extraction of a byte, word, dword and qword from an XMM register into either a memory location or integer register.

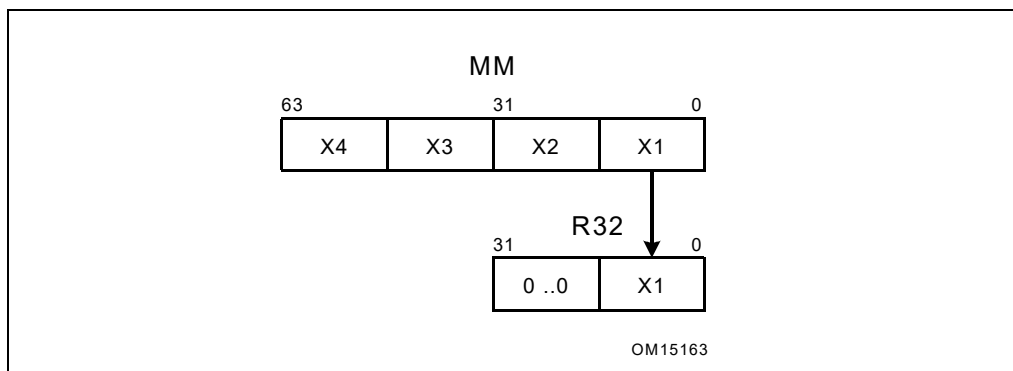

Figure 6-5. PEXTRW Instruction

Example 6-9. PEXTRW Instruction Code

```

; Input:
;   eax    source value
;   immediate value: "0"
; Output:
;   edx    32-bit integer register containing the extracted word in the
;           low-order bits & the high-order bits zero-extended
movq  mm0, [eax]
pextrw edx, mm0, 0

```

6.4.7 Insert Data Element

The PINSRW instruction in SSE loads a word from the lower half of a 32-bit integer register or from memory and inserts it in an MMX technology destination register at a position defined by the two least significant bits of the immediate constant. Insertion is done in such a way that three other words from the destination register are left untouched. See Figure 6-6 and Example 6-10.

With SSE2, PINSRW can insert a word from the lower 16 bits of an integer register or memory into an XMM register. SSE4.1 provides insertion of a byte, dword and qword from either a memory location or integer register into an XMM register.

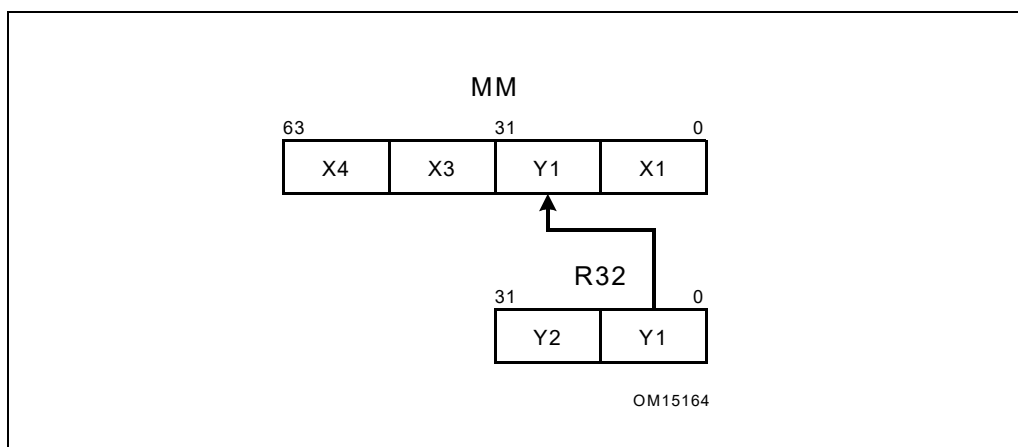

Figure 6-6. PINSRW Instruction

Example 6-10. PINSRW Instruction Code

```

; Input:
;   edx    pointer to source value
; Output:
;   mm0    register with new 16-bit value inserted
;
mov  eax, [edx]
pinsrw mm0, eax, 1

```

If all of the operands in a register are being replaced by a series of PINSRW instructions, it can be useful to clear the content and break the dependence chain by either using the PXOR instruction or loading the register. See Example 6-11 and Section 3.5.1.7, “Clearing Registers and Dependency Breaking Idioms.”

Example 6-11. Repeated PINSRW Instruction Code

```

; Input:
;     edx      pointer to structure containing source
;              values at offsets: of +0, +10, +13, and +24
;              immediate value: "1"
; Output:
;     MMX      register with new 16-bit value inserted
;
pxor   mm0, mm0 ; Breaks dependency on previous value of mm0
mov    eax, [edx]
pinsrw mm0, eax, 0
mov    eax, [edx+10]
pinsrw mm0, eax, 1
mov    eax, [edx+13]
pinsrw mm0, eax, 2
mov    eax, [edx+24]
pinsrw mm0, eax, 3

```

6.4.8 Non-Unit Stride Data Movement

SSE4.1 provides instructions to insert a data element from memory into an XMM register, and to extract a data element from an XMM register into memory directly. Separate instructions are provided to handle floating-point data and integer byte, word, or dword. These instructions are suited for vectorizing code that loads/stores non-unit stride data from memory, see Example 6-12.

Example 6-12. Non-Unit Stride Load/Store Using SSE4.1 Instructions

<pre> /* Goal: Non-Unit Stride Load Dwords*/ movd xmm0, [addr] pinsrd xmm0, [addr + stride], 1 pinsrd xmm0, [addr + 2*stride], 2 pinsrd xmm0, [addr + 3*stride], 3 </pre>	<pre> /* Goal: Non-Unit Stride Store Dwords*/ movd [addr], xmm0 pextrd [addr + stride], xmm0, 1 pextrd [addr + 2*stride], xmm0, 2 pextrd [addr + 3*stride], xmm0, 3 </pre>
--	---

Example 6-13 provides two examples: using INSERTPS and PEXTRD to perform gather operations on floating-point data; using EXTRACTPS and PEXTRD to perform scatter operations on floating-point data.

Example 6-13. Scatter and Gather Operations Using SSE4.1 Instructions

<pre> /* Goal: Gather Operation*/ movd eax, xmm0 movss xmm1, [addr + 4*eax] pextrd eax, xmm0, 1 insertps xmm1, [addr + 4*eax], 1 pextrd eax, xmm0, 2 insertps xmm1, [addr + 4*eax], 2 pextrd eax, xmm0, 3 insertps xmm1, [addr + 4*eax], 3 </pre>	<pre> /* Goal: Scatter Operation*/ movd eax, xmm0 movss [addr + 4*eax], xmm1 pextrd eax, xmm0, 1 extractps [addr + 4*eax], xmm1, 1 pextrd eax, xmm0, 2 extractps [addr + 4*eax], xmm1, 2 pextrd eax, xmm0, 3 extractps [addr + 4*eax], xmm1, 3 </pre>
--	--

6.4.9 Move Byte Mask to Integer

The PMOVMSKB instruction returns a bit mask formed from the most significant bits of each byte of its source operand. When used with 64-bit MMX registers, this produces an 8-bit mask, zeroing out the upper 24 bits in the destination register. When used with 128-bit XMM registers, it produces a 16-bit mask, zeroing out the upper 16 bits in the destination register.

The 64-bit version of this instruction is shown in Figure 6-7 and Example 6-14.

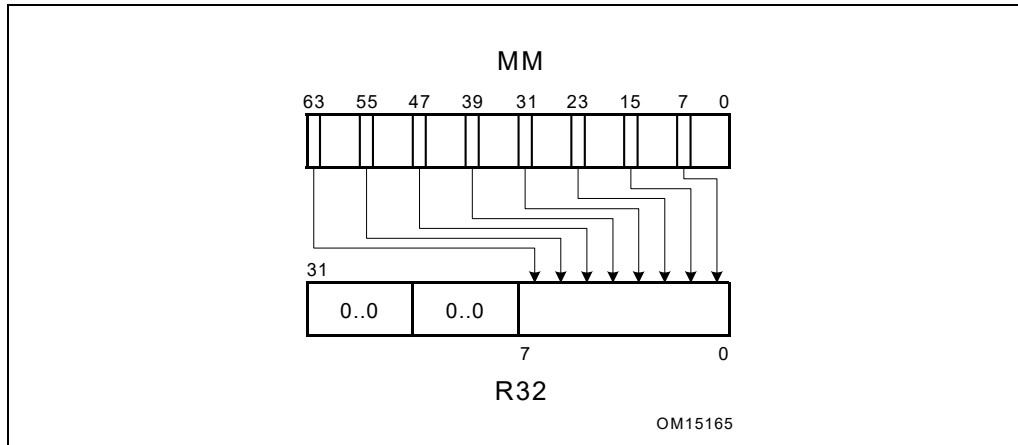

Figure 6-7. PMOVMSKB Instruction

Example 6-14. PMOVMSKB Instruction Code

```
; Input:
;   source value
; Output:
;   32-bit register containing the byte mask in the lower eight bits
;
movq  mm0, [edi]
pmovmskb eax, mm0
```

6.4.10 Packed Shuffle Word for 64-bit Registers

The PSHUFW instruction uses the immediate (IMM8) operand to select between the four words in either two MMX registers or one MMX register and a 64-bit memory location. SSE2 provides PSHUFLW to shuffle the lower four words into an XMM register. In addition to the equivalent to the PSHUFW, SSE2 also provides PSHUFHW to shuffle the higher four words. Furthermore, SSE2 offers PSHUFD to shuffle four dwords into an XMM register. All of these four PSHUF instructions use an immediate byte to encode the data path of individual words within the corresponding 8 bytes from source to destination, shown in Table 6-1.

Table 6-1. PSHUF Encoding

Bits	Words
1 - 0	0
3 - 2	1
5 - 4	2
7 - 6	3

6.4.11 Packed Shuffle Word for 128-bit Registers

The PSHUFLW/PSHUFHW instruction performs a full shuffle of any source word field within the low/high 64 bits to any result word field in the low/high 64 bits, using an 8-bit immediate operand; other high/low 64 bits are passed through from the source operand.

PSHUFD performs a full shuffle of any double-word field within the 128-bit source to any double-word field in the 128-bit result, using an 8-bit immediate operand.

No more than 3 instructions, using PSHUFLW/PSHUFHW/PSHUFD, are required to implement many common data shuffling operations. Broadcast, Swap, and Reverse are illustrated in Example 6-15 and Example 6-16.

Example 6-15. Broadcast a Word Across XMM, Using 2 SSE2 Instructions

/* Goal: Broadcast the value from word 5 to all words */	
/* Instruction	Result */
	7 6 5 4 3 2 1 0
PSHUFHW (3,2,1,1)	7 6 5 5 3 2 1 0
PSHUFD (2,2,2,2)	5 5 5 5 5 5 5

Example 6-16. Swap/Reverse words in an XMM, Using 3 SSE2 Instructions

/* Goal: Swap the values in word 6 and word 1 */	/* Goal: Reverse the order of the words */
/* Instruction	Result */
	7 6 5 4 3 2 1 0
PSHUFD (3,0,1,2)	7 6 1 0 3 2 5 4
PSHUFHW (3,1,2,0)	7 1 6 0 3 2 5 4
PSHUFD (3,0,1,2)	7 1 5 4 3 2 6 0
	/* Instruction
	Result */
	7 6 5 4 3 2 1 0
PSHUFLW (0,1,2,3)	7 6 5 4 0 1 2 3
PSHUFHW (0,1,2,3)	4 5 6 7 0 1 2 3
PSHUFD (1,0,3,2)	0 1 2 3 4 5 6 7

6.4.12 Shuffle Bytes

SSSE3 provides PSHUFB; this instruction carries out byte manipulation within a 16 byte range. PSHUFB can replace up to 12 other instructions: including SHIFT, OR, AND and MOV.

Use PSHUFB if the alternative uses 5 or more instructions.

6.4.13 Conditional Data Movement

SSE4.1 provides two packed blend instructions on byte and word data elements in 128-bit operands. Packed blend instructions conditionally copies data elements from selected positions in the source to the corresponding data element using a mask specified by an immediate control byte or an implied XMM register (XMM0). The mask can be generated by a packed compare instruction for example. Thus packed blend instructions are most useful for vectorizing conditional flows within a loop and can be more efficient than inserting single element one at a time for some situations.

6.4.14 Unpacking/interleaving 64-bit Data in 128-bit Registers

The PUNPCKLQDQ/PUNPCHQDQ instructions interleave the low/high-order 64-bits of the source operand and the low/high-order 64-bits of the destination operand. It then writes the results to the destination register.

The high/low-order 64-bits of the source operands are ignored.

6.4.15 Data Movement

There are two additional instructions to enable data movement from 64-bit SIMD integer registers to 128-bit SIMD registers.

The MOVQ2DQ instruction moves the 64-bit integer data from an MMX register (source) to a 128-bit destination register. The high-order 64 bits of the destination register are zeroed-out.

The MOVDQ2Q instruction moves the low-order 64-bits of integer data from a 128-bit source register to an MMX register (destination).

6.4.16 Conversion Instructions

SSE provides Instructions to support 4-wide conversion of single-precision data to/from double-word integer data. Conversions between double-precision data to double-word integer data have been added in SSE2.

SSE4.1 provides 4 rounding instructions to convert floating-point values to integer values with rounding control specified in a more flexible manner and independent of the rounding control in MXCSR. The integer values produced by ROUNDxx instructions are maintained as floating-point data.

SSE4.1 also provides instructions to convert integer data from:

- Packed bytes to packed word/dword/qword format using either sign extension or zero extension.
- Packed words to packed dword/qword format using either sign extension or zero extension.
- Packed dword to packed qword format using either sign extension or zero extension.

6.5 GENERATING CONSTANTS

SIMD integer instruction sets do not have instructions that will load immediate constants to the SIMD registers.

The following code segments generate frequently used constants in the SIMD register. These examples can also be extended in SSE2 by substituting MMX with XMM registers. See Example 6-17.

Example 6-17. Generating Constants

```

pxor   mm0, mm0 ; generate a zero register in MM0
pcmpeq mm1, mm1 ; Generate all 1's in register MM1,
                ; which is -1 in each of the packed
                ; data type fields

pxor   mm0, mm0
pcmpeq mm1, mm1
psubb  mm0, mm1 [psubw mm0, mm1] (psubd mm0, mm1)
                ; three instructions above generate
                ; the constant 1 in every
                ; packed-byte [or packed-word]
                ; (or packed-dword) field

pcmpeq mm1, mm1
psrlw  mm1, 16-n (psrld mm1, 32-n)
                ; two instructions above generate
                ; the signed constant  $2^n-1$  in every
                ; packed-word (or packed-dword) field

pcmpeq mm1, mm1
psllw  mm1, n (pslld mm1, n)
                ; two instructions above generate
                ; the signed constant  $-2n$  in every
                ; packed-word (or packed-dword) field

```

NOTE

Because SIMD integer instruction sets do not support shift instructions for bytes, $2n-1$ and $-2n$ are relevant only for packed words and packed doublewords.

6.6 BUILDING BLOCKS

This section describes instructions and algorithms which implement common code building blocks.

6.6.1 Absolute Difference of Unsigned Numbers

Example 6-18 computes the absolute difference of two unsigned numbers. It assumes an unsigned packed-byte data type.

Here, we make use of the subtract instruction with unsigned saturation. This instruction receives UNSIGNED operands and subtracts them with UNSIGNED saturation. This support exists only for packed bytes and packed words, not for packed doublewords.

Example 6-18. Absolute Difference of Two Unsigned Numbers

```

; Input:
;   MM0 source operand
;   MM1 source operand
; Output:
;   MM0 absolute difference of the unsigned operands

```

Example 6-18. Absolute Difference of Two Unsigned Numbers (Contd.)

```

movq   mm2, mm0   ; make a copy of mm0
psubusbmm0, mm1   ; compute difference one way
psubusbmm1, mm2   ; compute difference the other way
por    mm0, mm1   ; OR them together

```

This example will not work if the operands are signed. Note that PSADBW may also be used in some situations. See Section 6.6.9 for details.

6.6.2 Absolute Difference of Signed Numbers

Example 6-19 computes the absolute difference of two signed numbers using SSSE3 instruction PABSW. This sequence is more efficient than using previous generation of SIMD instruction extensions.

Example 6-19. Absolute Difference of Signed Numbers

```

;Input:
;   XMM0 signed source operand
;   XMM1 signed source operand
;Output:
;   XMM1 absolute difference of the unsigned operands
psubw  xmm0, xmm1 ; subtract words
pabsw  xmm1, xmm0 ; results in XMM1

```

6.6.3 Absolute Value

Example 6-20 show an MMX code sequence to compute $|X|$, where X is signed. This example assumes signed words to be the operands.

With SSSE3, this sequence of three instructions can be replaced by the PABSW instruction. Additionally, SSSE3 provides a 128-bit version using XMM registers and supports byte, word and doubleword granularity.

Example 6-20. Computing Absolute Value

```

;Input:
;   MM0      signed source operand
;Output:
;   MM1      ABS(MM0)
pxor   mm1, mm1 ; set mm1 to all zeros
psubw  mm1, mm0 ; make each mm1 word contain the
                ; negative of each mm0 word
pmaxswmm1, mm0 ; mm1 will contain only the positive
                ; (larger) values - the absolute value

```

NOTE

The absolute value of the most negative number (that is, 8000H for 16-bit) cannot be represented using positive numbers. This algorithm will return the original value for the absolute value (8000H).

6.6.4 Pixel Format Conversion

SSSE3 provides the PSHUFB instruction to carry out byte manipulation within a 16-byte range. PSHUFB can replace a set of up to 12 other instructions, including SHIFT, OR, AND and MOV.

Use PSHUFB if the alternative code uses 5 or more instructions. Example 6-21 shows the basic form of conversion of color pixel formats.

Example 6-21. Basic C Implementation of RGBA to BGRA Conversion

```
Standard C Code:
struct RGBA{BYTE r,g,b,a;};
struct BGRA{BYTE b,g,r,a;};

void BGRA_RGBA_Convert(BGRA *source, RGBA *dest, int num_pixels)
{
    for(int i = 0; i < num_pixels; i++){
        dest[i].r = source[i].r;
        dest[i].g = source[i].g;
        dest[i].b = source[i].b;
        dest[i].a = source[i].a;
    }
}
```

Example 6-22 and Example 6-23 show SSE2 code and SSSE3 code for pixel format conversion. In the SSSE3 example, PSHUFB replaces six SSE2 instructions.

Example 6-22. Color Pixel Format Conversion Using SSE2

```
; Optimized for SSE2
mov esi, src
mov edi, dest
mov ecx, iterations
movdqa xmm0, ag_mask //{0,ff,0,ff,0,ff,0,ff,0,ff,0,ff,0,ff}
movdqa xmm5, rb_mask //{ff,0,ff,0,ff,0,ff,0,ff,0,ff,0,ff,0}
mov eax, remainder

convert16Pixs // 16 pixels, 64 byte per iteration
movdqa xmm1, [esi] // xmm1 = [r3g3b3a3,r2g2b2a2,r1g1b1a1,r0g0b0a0]
movdqa xmm2, xmm1
movdqa xmm7, xmm1 //xmm7 abgr
psrlq xmm2, 16 //xmm2 00ab
pslld xmm1, 16 //xmm1 gr00

por xmm1, xmm2 //xmm1 grab
pand xmm7, xmm0 //xmm7 a0g0
pand xmm1, xmm5 //xmm1 0r0b
por xmm1, xmm7 //xmm1 argb
movdqa [edi], xmm1
```

Example 6-22. Color Pixel Format Conversion Using SSE2 (Contd.)

```

//repeats for another 3*16 bytes
...

add esi, 64
add edi, 64
sub ecx, 1
jnz convert16Pixs

```

Example 6-23. Color Pixel Format Conversion Using SSSE3

```

; Optimized for SSSE3
mov esi, src
mov edi, dest
mov ecx, iterations
movdqa xmm0, _shufb
// xmm0 = [15,12,13,14,11,8,9,10,7,4,5,6,3,0,1,2]
mov eax, remainder

convert16Pixs: // 16 pixels, 64 byte per iteration
movdqa xmm1, [esi]
// xmm1 = [r3g3b3a3,r2g2b2a2,r1g1b1a1,r0g0b0a0]
movdqa xmm2, [esi+16]
pshufb xmm1, xmm0
// xmm1 = [b3g3r3a3,b2g2r2a2,b1g1r1a1,b0g0r0a0]
movdqa [edi], xmm1

//repeats for another 3*16 bytes
...

add esi, 64
add edi, 64
sub ecx, 1
jnz convert16Pixs

```

6.6.5 Endian Conversion

The PSHUFB instruction can also be used to reverse byte ordering within a doubleword. It is more efficient than traditional techniques, such as BSWAP.

Example 6-24 (a) shows the traditional technique using four BSWAP instructions to reverse the bytes within a DWORD. Each BSWAP requires executing two micro-ops. In addition, the code requires 4 loads and 4 stores for processing 4 DWORDs of data.

Example 6-24 (b) shows an SSSE3 implementation of endian conversion using PSHUFB. The reversing of four DWORDs requires one load, one store, and PSHUFB.

On Intel Core microarchitecture, reversing 4 DWORDs using PSHUFB can be approximately twice as fast as using BSWAP.

Example 6-24. Big-Endian to Little-Endian Conversion

<pre> ;(a) Using BSWAP lea eax, src lea ecx, dst mov edx, elCount start: mov edi, [eax] mov esi, [eax+4] bswap edi mov ebx, [eax+8] bswap esi mov ebp, [eax+12] mov [ecx], edi mov [ecx+4], esi bswap ebx mov [ecx+8], ebx bswap ebp mov [ecx+12], ebp add eax, 16 add ecx, 16 sub edx, 4 jnz start </pre>	<pre> ;(b) Using PSHUFB __declspec(align(16)) BYTE bswapMASK[16] = {3,2,1,0, 7,6,5,4, 11,10,9,8, 15,14,13,12}; lea eax, src lea ecx, dst mov edx, elCount movaps xmm7, bswapMASK start: movdqa xmm0, [eax] pshufb xmm0, xmm7 movdqa [ecx], xmm0 add eax, 16 add ecx, 16 sub edx, 4 jnz start </pre>
--	--

6.6.6 Clipping to an Arbitrary Range [High, Low]

This section explains how to clip a values to a range [HIGH, LOW]. Specifically, if the value is less than LOW or greater than HIGH, then clip to LOW or HIGH, respectively. This technique uses the packed-add and packed-subtract instructions with saturation (signed or unsigned), which means that this technique can only be used on packed-byte and packed-word data types.

The examples in this section use the constants PACKED_MAX and PACKED_MIN and show operations on word values. For simplicity, we use the following constants (corresponding constants are used in case the operation is done on byte values):

```

PACKED_MAX equals 0X7FFF7FFF7FFF7FFF
PACKED_MIN equals 0X8000800080008000
PACKED_LOW  contains the value LOW  in all four words of the packed-words data type
PACKED_HIGH contains the value HIGH in all four words of the packed-words data type
PACKED_USMAX all values equal 1
HIGH_US adds the HIGH value to all data elements (4 words) of PACKED_MIN
LOW_US adds the LOW value to all data elements (4 words) of PACKED_MIN

```

6.6.6.1 Highly Efficient Clipping

For clipping signed words to an arbitrary range, the PMAWSW and PMINSW instructions may be used. For clipping unsigned bytes to an arbitrary range, the PMAWSB and PMINSB instructions may be used.

Example 6-25 shows how to clip signed words to an arbitrary range; the code for clipping unsigned bytes is similar.

Example 6-25. Clipping to a Signed Range of Words [High, Low]

```
; Input:
;   MM0   signed source operands
; Output:
;   MM0   signed words clipped to the signed
;         range [high, low]
pminsw mm0, packed_high
pmaxswmm0, packed_low
```

With SSE4.1, Example 6-25 can be easily extended to clip signed bytes, unsigned words, signed and unsigned dwords.

Example 6-26. Clipping to an Arbitrary Signed Range [High, Low]

```
; Input:
;   MM0           signed source operands
; Output:
;   MM1           signed operands clipped to the unsigned
;               range [high, low]
paddw mm0, packed_min ; add with no saturation
;               ; 0x8000 to convert to unsigned
padduswmm0, (packed_usmax - high_us)
;               ; in effect this clips to high
psubuswmm0, (packed_usmax - high_us + low_us)
;               ; in effect this clips to low
paddw mm0, packed_low ; undo the previous two offsets
```

The code above converts values to unsigned numbers first and then clips them to an unsigned range. The last instruction converts the data back to signed data and places the data within the signed range.

Conversion to unsigned data is required for correct results when $(\text{High} - \text{Low}) < 0\text{X}8000$. If $(\text{High} - \text{Low}) \geq 0\text{X}8000$, simplify the algorithm as in Example 6-27.

Example 6-27. Simplified Clipping to an Arbitrary Signed Range

```
; Input:   MM0   signed source operands
; Output:  MM1   signed operands clipped to the unsigned
;           range [high, low]
paddssw mm0, (packed_max - packed_high)
;           ; in effect this clips to high
psubssw mm0, (packed_usmax - packed_high + packed_low)
;           ; clips to low
paddw mm0, low ; undo the previous two offsets
```

This algorithm saves a cycle when it is known that $(\text{High} - \text{Low}) \geq 0\text{x}8000$. The three-instruction algorithm does not work when $(\text{High} - \text{Low}) < 0\text{x}8000$ because 0xffff minus any number $< 0\text{x}8000$ will yield a number greater in magnitude than $0\text{x}8000$ (which is a negative number).

When the second instruction, `psubssw MM0, (0xffff - High + Low)` in the three-step algorithm (Example 6-27) is executed, a negative number is subtracted. The result of this subtraction causes the values in MM0 to be increased instead of decreased, as should be the case, and an incorrect answer is generated.

6.6.6.2 Clipping to an Arbitrary Unsigned Range [High, Low]

Example 6-28 clips an unsigned value to the unsigned range [High, Low]. If the value is less than low or greater than high, then clip to low or high, respectively. This technique uses the packed-add and packed-subtract instructions with unsigned saturation, thus the technique can only be used on packed-bytes and packed-words data types.

Figure 6-28 illustrates operation on word values.

Example 6-28. Clipping to an Arbitrary Unsigned Range [High, Low]

```

; Input:
;           MM0    unsigned source operands
; Output:
;           MM1    unsigned operands clipped to the unsigned
;                   range [HIGH, LOW]
paddusw    mm0, 0xffff - high
;                   ; in effect this clips to high
psubusw    mm0, (0xffff - high + low)
;                   ; in effect this clips to low
paddw      mm0, low
;                   ; undo the previous two offsets

```

6.6.7 Packed Max/Min of Byte, Word and Dword

The PMAWSW instruction returns the maximum between four signed words in either of two SIMD registers, or one SIMD register and a memory location.

The PMINSW instruction returns the minimum between the four signed words in either of two SIMD registers, or one SIMD register and a memory location.

The PMASUB instruction returns the maximum between the eight unsigned bytes in either of two SIMD registers, or one SIMD register and a memory location.

The PMINUB instruction returns the minimum between the eight unsigned bytes in either of two SIMD registers, or one SIMD register and a memory location.

SSE2 extended PMAWSW/PMASUB/PMINSW/PMINUB to 128-bit operations. SSE4.1 adds 128-bit operations for signed bytes, unsigned word, signed and unsigned dword.

6.6.8 Packed Multiply Integers

The PMULHUW/PMULHW instruction multiplies the unsigned/signed words in the destination operand with the unsigned/signed words in the source operand. The high-order 16 bits of the 32-bit intermediate results are written to the destination operand. The PMULLW instruction multiplies the signed words in the destination operand with the signed words in the source operand. The low-order 16 bits of the 32-bit intermediate results are written to the destination operand.

SSE2 extended PMULHUW/PMULHW/PMULLW to 128-bit operations and adds PMULUDQ.

The PMULUDQ instruction performs an unsigned multiply on the lower pair of double-word operands within 64-bit chunks from the two sources; the full 64-bit result from each multiplication is returned to the destination register.

This instruction is added in both a 64-bit and 128-bit version; the latter performs 2 independent operations, on the low and high halves of a 128-bit register.

SSE4.1 adds 128-bit operations of PMULDQ and PMULLD. The PMULLD instruction multiplies the signed dwords in the destination operand with the signed dwords in the source operand. The low-order 32 bits of the 64-bit intermediate results are written to the destination operand. The PMULDQ instruction multiplies the two low-order, signed dwords in the destination operand with the two low-order, signed dwords in the source operand and stores two 64-bit results in the destination operand.

6.6.9 Packed Sum of Absolute Differences

The PSADBW instruction computes the absolute value of the difference of unsigned bytes for either two SIMD registers, or one SIMD register and a memory location. The differences of 8 pairs of unsigned bytes are then summed to produce a word result in the lower 16-bit field, and the upper three words are set to zero. With SSE2, PSADBW is extended to compute two word results.

The subtraction operation presented above is an absolute difference. That is, $T = \text{ABS}(X-Y)$. Byte values are stored in temporary space, all values are summed together, and the result is written to the lower word of the destination register.

Motion estimation involves searching reference frames for best matches. Sum absolute difference (SAD) on two blocks of pixels is a common ingredient in video processing algorithms to locate matching blocks of pixels. PSADBW can be used as building blocks for finding best matches by way of calculating SAD results on 4x4, 8x4, 8x8 blocks of pixels.

6.6.10 MPSADBW and PHMINPOSUW

The MPSADBW instruction in SSE4.1 performs eight SAD operations. Each SAD operation produces a word result from 4 pairs of unsigned bytes. With 8 SAD result in an XMM register, PHMINPOSUM can help search for the best match between eight 4x4 pixel blocks.

For motion estimation algorithms, MPSADBW is likely to improve over PSADBW in several ways:

- Simplified data movement to construct packed data format for SAD computation on pixel blocks.
- Higher throughput in terms of SAD results per iteration (less iteration required per frame).
- MPSADBW results are amenable to efficient search using PHMINPOSUW.

Examples of MPSADBW vs. PSADBW for 4x4 and 8x8 block search can be found in the white paper listed in the reference section of Chapter 1.

6.6.11 Packed Average (Byte/Word)

The PAVGB and PAVGW instructions add the unsigned data elements of the source operand to the unsigned data elements of the destination register, along with a carry-in. The results of the addition are then independently shifted to the right by one bit position. The high order bits of each element are filled with the carry bits of the corresponding sum.

The destination operand is an SIMD register. The source operand can either be an SIMD register or a memory operand.

The PAVGB instruction operates on packed unsigned bytes and the PAVGW instruction operates on packed unsigned words.

6.6.12 Complex Multiply by a Constant

Complex multiplication is an operation which requires four multiplications and two additions. This is exactly how the PMADDWD instruction operates. In order to use this instruction, you need to format the data into multiple 16-bit values. The real and imaginary components should be 16-bits each. Consider Example 6-29, which assumes that the 64-bit MMX registers are being used:

- Let the input data be DR and DI, where DR is real component of the data and DI is imaginary component of the data.
- Format the constant complex coefficients in memory as four 16-bit values [CR -CI CI CR]. Remember to load the values into the MMX register using MOVQ.
- The real component of the complex product is $PR = DR*CR - DI*CI$ and the imaginary component of the complex product is $PI = DR*CI + DI*CR$.

- The output is a packed doubleword. If needed, a pack instruction can be used to convert the result to 16-bit (thereby matching the format of the input).

Example 6-29. Complex Multiply by a Constant

```

; Input:
;      MM0      complex value, Dr, Di
;      MM1      constant complex coefficient in the form
;               [Cr -Ci Ci Cr]
; Output:
;      MM0      two 32-bit dwords containing [Pr Pi]
;
punpckldq  mm0, mm0  ; makes [dr di dr di]
pmaddwd   mm0, mm1  ; done, the result is
;                 ; [(Dr*Cr-Di*Ci)(Dr*Ci+Di*Cr)]

```

6.6.13 Packed 64-bit Add/Subtract

The PADDQ/PSUBQ instructions add/subtract quad-word operands within each 64-bit chunk from the two sources; the 64-bit result from each computation is written to the destination register. Like the integer ADD/SUB instruction, PADDQ/PSUBQ can operate on either unsigned or signed (two's complement notation) integer operands.

When an individual result is too large to be represented in 64-bits, the lower 64-bits of the result are written to the destination operand and therefore the result wraps around. These instructions are added in both a 64-bit and 128-bit version; the latter performs 2 independent operations, on the low and high halves of a 128-bit register.

6.6.14 128-bit Shifts

The PSLLDQ/PSRLDQ instructions shift the first operand to the left/right by the number of bytes specified by the immediate operand. The empty low/high-order bytes are cleared (set to zero).

If the value specified by the immediate operand is greater than 15, then the destination is set to all zeros.

6.6.15 PTEST and Conditional Branch

SSE4.1 offers PTEST instruction that can be used in vectorizing loops with conditional branches. PTEST is an 128-bit version of the general-purpose instruction TEST. The ZF or CF field of the EFLAGS register are modified as a result of PTEST.

Example 6-30(a) depicts a loop that requires a conditional branch to handle the special case of divide-by-zero. In order to vectorize such loop, any iteration that may encounter divide-by-zero must be treated outside the vectorizable iterations.

Example 6-30. Using PTEST to Separate Vectorizable and non-Vectorizable Loop Iterations

<pre>(a) /* Loops requiring infrequent exception handling*/ float a[CNT]; unsigned int i; for (i=0;i<CNT;i++) { if (a[i] != 0.0) { a[i] = 1.0f/a[i]; } else { call DivException(); } } }</pre>	<pre>(b) /* PTEST enables early out to handle infrequent, non-vectorizable portion*/ xor eax,eax movaps xmm7, [all_ones] xorps xmm6, xmm6 lp: movaps xmm0, a[eax] cmpeqps xmm6, xmm0 ; convert each non-zero to ones ptest xmm6, xmm7 jnc zero_present; carry will be set if all 4 were non-zero movaps xmm1, [_1_of_] divps xmm1, xmm0 movaps a[eax], xmm1 add eax, 16 cmp eax, CNT jnz lp jmp end zero_present: // execute one by one, call // exception when value is zero</pre>
--	---

Example 6-30(b) shows an assembly sequence that uses PTEST to cause an early-out branch whenever any one of the four floating-point values in xmm0 is zero. The fall-through path enables the rest of the floating-point calculations to be vectorized because none of the four values are zero.

6.6.16 Vectorization of Heterogeneous Computations across Loop Iterations

Vectorization techniques on unrolled loops generally rely on repetitive, homogeneous operations between each loop iteration. Using variable blend instructions, vectorization of heterogeneous operations across loop iterations may be possible.

Example 6-31(a) depicts a simple heterogeneous loop. The heterogeneous operation and conditional branch makes simple loop-unrolling techniques infeasible for vectorization.

Example 6-31. Using Variable BLEND to Vectorize Heterogeneous Loops

<pre>(a) /* Loops with heterogeneous operation across iterations*/ float a[CNT]; unsigned int i; for (i=0;i<CNT;i++) { if (a[i] > b[i]) { a[i] += b[i]; } else { a[i] -= b[i]; } } }</pre>	<pre>(b) /* Vectorize Condition Flow with BLENDVPS*/ xor eax,eax lp: movaps xmm0, a[eax] movaps xmm1, b[eax] movaps xmm2, xmm0 // compare a and b values cmpgtps xmm0, xmm1 // xmm3 - will hold -b movaps xmm3, [SIGN_BIT_MASK] xorps xmm3, xmm1</pre>
---	--

Example 6-31. Using Variable BLEND to Vectorize Heterogeneous Loops (Contd.)

	<pre> // select values for the add operation, // true condition produce a+b, false will become a+(-b) // blend mask is xmm0 blendvps xmm1,xmm3, xmm0 addps xmm2, xmm1 movaps a[eax], xmm2 add eax, 16 cmp eax, CNT jnz lp </pre>
--	---

Example 6-31(b) depicts an assembly sequence that uses BLENDVPS to vectorize the handling of heterogeneous computations occurring across four consecutive loop iterations.

6.6.17 Vectorization of Control Flows in Nested Loops

The PTEST and BLENDVPx instructions can be used as building blocks to vectorize more complex control-flow statements, where each control flow statement is creating a “working” mask used as a predicate of which the conditional code under the mask will operate.

The Mandelbrot-set map evaluation is useful to illustrate a situation with more complex control flows in nested loops. The Mandelbrot-set is a set of height values mapped to a 2-D grid. The height value is the number of Mandelbrot iterations (defined over the complex number space as $I_n = I_{n-1}^2 + I_0$) needed to get $|I_n| > 2$. It is common to limit the map generation by setting some maximum threshold value of the height, all other points are assigned with a height equal to the threshold. Example 6-32 shows an example of Mandelbrot map evaluation implemented in C.

Example 6-32. Baseline C Code for Mandelbrot Set Map Evaluation

```

#define DIMX (64)
#define DIMY (64)
#define X_STEP (0.5f/DIMX)
#define Y_STEP (0.4f/(DIMY/2))
int map[DIMX][DIMY];

void mandelbrot_C()
{
    int i,j;
    float x,y;
    for (i=0,x=-1.8f;i<DIMX;i++,x+=X_STEP)
    {
        for (j=0,y=-0.2f;j<DIMY/2;j++,y+=Y_STEP)
        {float sx,sy;
            int iter = 0;
            sx = x;
            sy = y;

```

Example 6-32. Baseline C Code for Mandelbrot Set Map Evaluation (Contd.)

```

        while (iter < 256)
        {   if (sx*sx + sy*sy >= 4.0f)   break;
            float old_sx = sx;
            sx = x + sx*sx - sy*sy;
            sy = y + 2*old_sx*sy;
            iter++;
        }
        map[i][j] = iter;
    }
}

```

Example 6-33 shows a vectorized implementation of Mandelbrot map evaluation. Vectorization is not done on the inner most loop, because the presence of the break statement implies the iteration count will vary from one pixel to the next. The vectorized version take into account the parallel nature of 2-D, vectorize over four iterations of Y values of 4 consecutive pixels, and conditionally handles three scenarios:

- In the inner most iteration, when all 4 pixels do not reach break condition, vectorize 4 pixels.
- When one or more pixels reached break condition, use blend intrinsics to accumulate the complex height vector for the remaining pixels not reaching the break condition and continue the inner iteration of the complex height vector.
- When all four pixels reached break condition, exit the inner loop.

Example 6-33. Vectorized Mandelbrot Set Map Evaluation Using SSE4.1 Intrinsics

```

__declspec(align(16)) float _INIT_Y_4[4] = {0,Y_STEP,2*Y_STEP,3*Y_STEP};
F32vec4 _F_STEP_Y(4*Y_STEP);
I32vec4 _L_ONE_ = _mm_set1_epi32(1);
F32vec4 _F_FOUR_(4.0f);
F32vec4 _F_TWO_(2.0f);

void mandelbrot_C()
{   int i,j;
    F32vec4 x,y;

    for (i = 0, x = F32vec4(-1.8f); i < DIMX; i ++, x += F32vec4(X_STEP))
    {
        for (j = DIMY/2, y = F32vec4(-0.2f) +
            *(F32vec4*)_INIT_Y_4; j < DIMY; j += 4, y += _F_STEP_Y)
        {   F32vec4 sx,sy;
            I32vec4 iter = _mm_setzero_si128();
            int scalar_iter = 0;
            sx = x;
            sy = y;

```

Example 6-33. Vectorized Mandelbrot Set Map Evaluation Using SSE4.1 Intrinsics (Contd.)

```

while (scalar_iter < 256)
{
    int mask = 0;
    F32vec4 old_sx = sx;
    __m128 vmask = _mm_cmpnlt_ps(sx*sx + sy*sy,_F_FOUR_);
    // if all data points in our vector are hitting the "exit" condition,
    // the vectorized loop can exit
    if (_mm_test_all_ones(_mm_castps_si128(vmask)))
        break;
        (continue)
// if non of the data points are out, we don't need the extra code which blends the results
    if (_mm_test_all_zeros(_mm_castps_si128(vmask),
        _mm_castps_si128(vmask)))
    {
        sx = x + sx*sx - sy*sy;
        sy = y + _F_TWO_*old_sx*sy;
        iter += _I_ONE_;
    }
    else
    {
// Blended flavour of the code, this code blends values from previous iteration with the values
// from current iteration. Only values which did not hit the "exit" condition are being stored;
// values which are already "out" are maintaining their value
        sx = _mm_blendv_ps(x + sx*sx - sy*sy,sx,vmask);
        sy = _mm_blendv_ps(y + _F_TWO_*old_sx*sy,sy,vmask);
        iter = l32vec4(_mm_blendv_epi8(iter + _I_ONE_,
            iter,_mm_castps_si128(vmask)));
    }
    scalar_iter++;
}
    _mm_storeu_si128((__m128i*)&map[i][j],iter);
}
}
}

```

6.7 MEMORY OPTIMIZATIONS

You can improve memory access using the following techniques:

- Avoiding partial memory accesses.
- Increasing the bandwidth of memory fills and video fills.
- Prefetching data with Streaming SIMD Extensions. See Chapter 9, "Optimizing Cache Usage."

MMX registers and XMM registers allow you to move large quantities of data without stalling the processor. Instead of loading single array values that are 8, 16, or 32 bits long, consider loading the values in a single quadword or double quadword and then incrementing the structure or array pointer accordingly.

Any data that will be manipulated by SIMD integer instructions should be loaded using either:

- An SIMD integer instruction that loads a 64-bit or 128-bit operand (for example: MOVQ MM0, M64).
- The register-memory form of any SIMD integer instruction that operates on a quadword or double quadword memory operand (for example, PMADDW MM0, M64).

All SIMD data should be stored using an SIMD integer instruction that stores a 64-bit or 128-bit operand (for example: MOVQ M64, MM0).

The goal of the above recommendations is twofold. First, the loading and storing of SIMD data is more efficient using the larger block sizes. Second, following the above recommendations helps to avoid mixing of 8-, 16-, or 32-bit load and store operations with SIMD integer technology load and store operations to the same SIMD data.

This prevents situations in which small loads follow large stores to the same area of memory, or large loads follow small stores to the same area of memory. The Pentium II, Pentium III, and Pentium 4 processors may stall in such situations. See Chapter 3 for details.

6.7.1 Partial Memory Accesses

Consider a case with a large load after a series of small stores to the same area of memory (beginning at memory address MEM). The large load stalls in the case shown in Example 6-34.

Example 6-34. A Large Load after a Series of Small Stores (Penalty)

```

mov  mem, eax      ; store dword to address "mem"
mov  mem + 4, ebx  ; store dword to address "mem + 4"
:
:
movq mm0, mem      ; load qword at address "mem", stalls

```

MOVQ must wait for the stores to write memory before it can access all data it requires. This stall can also occur with other data types (for example, when bytes or words are stored and then words or doublewords are read from the same area of memory). When you change the code sequence as shown in Example 6-35, the processor can access the data without delay.

Example 6-35. Accessing Data Without Delay

```

movd mm1, ebx      ; build data into a qword first
                    ; before storing it to memory
movd mm2, eax
psllq mm1, 32
por  mm1, mm2
movq mem, mm1      ; store SIMD variable to "mem" as
                    ; a qword
:
:
movq mm0, mem      ; load qword SIMD "mem", no stall

```

Consider a case with a series of small loads after a large store to the same area of memory (beginning at memory address MEM), as shown in Example 6-36. Most of the small loads stall because they are not aligned with the store. See Section 3.6.4, "Store Forwarding," for details.

Example 6-36. A Series of Small Loads After a Large Store

```

movq mem, mm0      ; store qword to address "mem"
:
:
mov  bx, mem + 2    ; load word at "mem + 2" stalls
mov  cx, mem + 4    ; load word at "mem + 4" stalls

```

The word loads must wait for the quadword store to write to memory before they can access the data they require. This stall can also occur with other data types (for example: when doublewords or words are stored and then words or bytes are read from the same area of memory).

When you change the code sequence as shown in Example 6-37, the processor can access the data without delay.

Example 6-37. Eliminating Delay for a Series of Small Loads after a Large Store

```

movq  mem, mm0    ; store qword to address "mem"
:
:
movq  mm1, mem    ; load qword at address "mem"
movd  eax, mm1    ; transfer "mem + 2" to eax from
                  ; MMX register, not memory

psrlq mm1, 32
shr   eax, 16
movd  ebx, mm1    ; transfer "mem + 4" to bx from
                  ; MMX register, not memory
and   ebx, 0ffffh

```

These transformations, in general, increase the number of instructions required to perform the desired operation. For Pentium II, Pentium III, and Pentium 4 processors, the benefit of avoiding forwarding problems outweighs the performance penalty due to the increased number of instructions.

6.7.2 Increasing Bandwidth of Memory Fills and Video Fills

It is beneficial to understand how memory is accessed and filled. A memory-to-memory fill (for example a memory-to-video fill) is defined as a 64-byte (cache line) load from memory which is immediately stored back to memory (such as a video frame buffer).

The following are guidelines for obtaining higher bandwidth and shorter latencies for sequential memory fills (video fills). These recommendations are relevant for all Intel architecture processors with MMX technology and refer to cases in which the loads and stores do not hit in the first- or second-level cache.

6.7.2.1 Increasing Memory Bandwidth Using the MOVDQ Instruction

Loading any size data operand will cause an entire cache line to be loaded into the cache hierarchy. Thus, any size load looks more or less the same from a memory bandwidth perspective. However, using many smaller loads consumes more microarchitectural resources than fewer larger stores. Consuming too many resources can cause the processor to stall and reduce the bandwidth that the processor can request of the memory subsystem.

Using MOVDQ to store the data back to UC memory (or WC memory in some cases) instead of using 32-bit stores (for example, MOVD) will reduce by three-quarters the number of stores per memory fill cycle. As a result, using the MOVDQ in memory fill cycles can achieve significantly higher effective bandwidth than using MOVD.

6.7.2.2 Increasing Memory Bandwidth by Loading and Storing to and from the Same DRAM Page

DRAM is divided into pages, which are not the same as operating system (OS) pages. The size of a DRAM page is a function of the total size of the DRAM and the organization of the DRAM. Page sizes of several Kilobytes are common. Like OS pages, DRAM pages are constructed of sequential addresses. Sequential memory accesses to the same DRAM page have shorter latencies than sequential accesses to different DRAM pages.

In many systems the latency for a page miss (that is, an access to a different page instead of the page previously accessed) can be twice as large as the latency of a memory page hit (access to the same page

as the previous access). Therefore, if the loads and stores of the memory fill cycle are to the same DRAM page, a significant increase in the bandwidth of the memory fill cycles can be achieved.

6.7.2.3 Increasing UC and WC Store Bandwidth by Using Aligned Stores

Using aligned stores to fill UC or WC memory will yield higher bandwidth than using unaligned stores. If a UC store or some WC stores cross a cache line boundary, a single store will result in two transactions on the bus, reducing the efficiency of the bus transactions. By aligning the stores to the size of the stores, you eliminate the possibility of crossing a cache line boundary, and the stores will not be split into separate transactions.

6.7.3 Reverse Memory Copy

Copying blocks of memory from a source location to a destination location in reverse order presents a challenge for software to make the most out of the machines capabilities while avoiding microarchitectural hazards. The basic, un-optimized C code is shown in Example 6-38.

The simple C code in Example 6-38 is sub-optimal, because it loads and stores one byte at a time (even in situations that hardware prefetcher might have brought data in from system memory to cache).

Example 6-38. Un-optimized Reverse Memory Copy in C

```
unsigned char* src;
unsigned char* dst;
while (len > 0)
{
    *dst-- = *src++;
    --len;
}
```

Using MOVDQA or MOVDQU, software can load and store up to 16 bytes at a time but must either ensure 16 byte alignment requirement (if using MOVDQA) or minimize the delays MOVDQU may encounter if data span across cache line boundary.

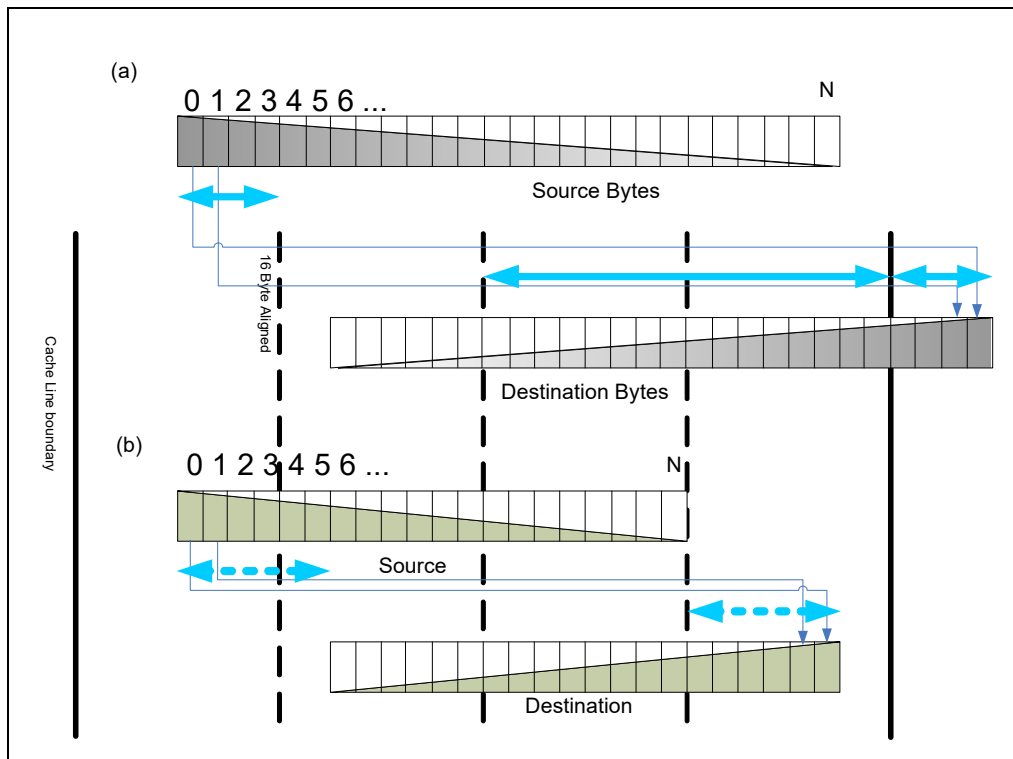

Figure 6-8. Data Alignment of Loads and Stores in Reverse Memory Copy

Given the general problem of arbitrary byte count to copy, arbitrary offsets of leading source byte and destination bytes, address alignment relative to 16 byte and cache line boundaries, these alignment situations can be a bit complicated. Figure 6-8 (a) and (b) depict the alignment situations of reverse memory copy of N bytes.

The general guidelines for dealing with unaligned loads and stores are (in order of importance):

- Avoid stores that span cache line boundaries.
- Minimize the number of loads that span cacheline boundaries.
- Favor 16-byte aligned loads and stores over unaligned versions.

In Figure 6-8 (a), the guidelines above can be applied to the reverse memory copy problem as follows:

1. Peel off several leading destination bytes until it aligns on 16 Byte boundary, then the ensuing destination bytes can be written to using MOVAPS until the remaining byte count falls below 16 bytes.
2. After the leading source bytes have been peeled (corresponding to step 1 above), the source alignment in Figure 6-8 (a) allows loading 16 bytes at a time using MOVAPS until the remaining byte count falls below 16 bytes.

Switching the byte ordering of each 16 bytes of data can be accomplished by a 16-byte mask with PSHUFB. The pertinent code sequence is shown in Example 6-39.

Example 6-39. Using PSHUFB to Reverse Byte Ordering 16 Bytes at a Time

```

__declspec(align(16)) static const unsigned char BswapMask[16] = {15,14,13,12,11,10,9,8,7,6,5,4,3,2,1,0};
    mov esi, src
    mov edi, dst
    mov ecx, len
    movaps xmm7, BswapMask
start:
    movdqa xmm0, [esi]
    pshufb xmm0, xmm7
    movdqa [edi-16], xmm0
sub edi, 16
    add esi, 16
    sub ecx, 16
    cmp ecx, 32
    jae start
    //handle left-overs

```

In Figure 6-8 (b), we also start with peeling the destination bytes:

1. Peel off several leading destination bytes until it aligns on 16 Byte boundary, then the ensuing destination bytes can be written to using MOVAPS until the remaining byte count falls below 16 bytes. However, the remaining source bytes are not aligned on 16 byte boundaries, replacing MOVDQA with MOVDQU for loads will inevitably run into cache line splits.
2. To achieve higher data throughput than loading unaligned bytes with MOVDQU, the 16 bytes of data targeted to each of 16 bytes of aligned destination addresses can be assembled using two aligned loads. This technique is illustrated in Figure 6-9.

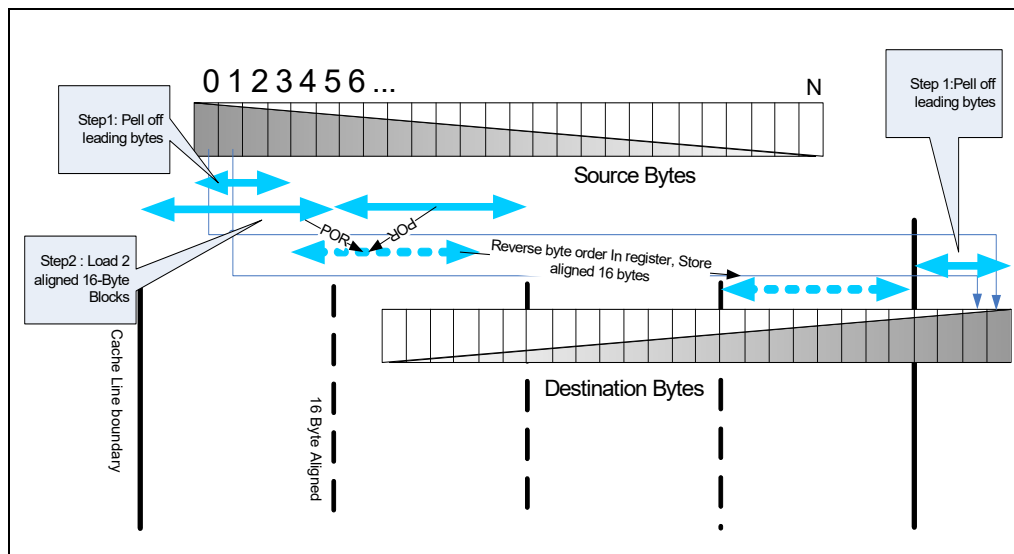

Figure 6-9. A Technique to Avoid Cacheline Split Loads in Reverse Memory Copy Using Two Aligned Loads

6.8 CONVERTING FROM 64-BIT TO 128-BIT SIMD INTEGERS

SSE2 defines a superset of 128-bit integer instructions currently available in MMX technology; the operation of the extended instructions remains. The superset simply operates on data that is twice as wide. This simplifies porting of 64-bit integer applications. However, there are few considerations:

- Computation instructions which use a memory operand that may not be aligned to a 16-byte boundary must be replaced with an unaligned 128-bit load (MOVDQU) followed by the same computation operation that uses instead register operands.
Use of 128-bit integer computation instructions with memory operands that are not 16-byte aligned will result in a #GP. Unaligned 128-bit loads and stores are not as efficient as corresponding aligned versions; this fact can reduce the performance gains when using the 128-bit SIMD integer extensions.
- General guidelines on the alignment of memory operands are:
 - The greatest performance gains can be achieved when all memory streams are 16-byte aligned.
 - Reasonable performance gains are possible if roughly half of all memory streams are 16-byte aligned and the other half are not.
 - Little or no performance gain may result if all memory streams are not aligned to 16-bytes. In this case, use of the 64-bit SIMD integer instructions may be preferable.
- Loop counters need to be updated because each 128-bit integer instruction operates on twice the amount of data as its 64-bit integer counterpart.
- Extension of the PSHUFW instruction (shuffle word across 64-bit integer operand) across a full 128-bit operand is emulated by a combination of the following instructions: PSHUFW, PSHUFLW, and PSHUFD.
- Use of the 64-bit shift by bit instructions (PSRLQ, PSLLQ) are extended to 128 bits by:
 - Use of PSRLQ and PSLLQ, along with masking logic operations.
 - A Code sequence rewritten to use the PSRLDQ and PSLLDQ instructions (shift double quad-word operand by bytes).

6.8.1 SIMD Optimizations and Microarchitectures

Pentium M, Intel Core Solo and Intel Core Duo processors have a different microarchitecture than Intel NetBurst microarchitecture. The following sections discuss optimizing SIMD code that targets Intel Core Solo and Intel Core Duo processors.

On Intel Core Solo and Intel Core Duo processors, LDDQU behaves identically to movdqu by loading 16 bytes of data irrespective of address alignment.

6.8.1.1 Packed SSE2 Integer versus MMX Instructions

In general, 128-bit SIMD integer instructions should be favored over 64-bit MMX instructions on Intel Core Solo and Intel Core Duo processors. This is because:

- Improved decoder bandwidth and more efficient micro-op flows relative to the Pentium M processor.
- Wider width of the XMM registers can benefit code that is limited by either decoder bandwidth or execution latency. XMM registers can provide twice the space to store data for in-flight execution. Wider XMM registers can facilitate loop-unrolling or in reducing loop overhead by halving the number of loop iterations.

In microarchitectures prior to Intel Core microarchitecture, execution throughput of 128-bit SIMD integer operations is basically the same as 64-bit MMX operations. Some shuffle/unpack/shift operations do not benefit from the front end improvements. The net impact of using 128-bit SIMD integer instruction on Intel Core Solo and Intel Core Duo processors is likely to be slightly positive overall, but there may be a few situations where their use will generate an unfavorable performance impact.

Intel Core microarchitecture generally executes 128-bit SIMD instructions more efficiently than previous microarchitectures in terms of latency and throughput, many of the limitations specific to Intel Core Duo, Intel Core Solo processors do not apply. The same is true of Intel Core microarchitecture relative to Intel NetBurst microarchitectures.

Enhanced Intel Core microarchitecture provides even more powerful 128-bit SIMD execution capabilities and more comprehensive sets of SIMD instruction extensions than Intel Core microarchitecture. The integer SIMD instructions offered by SSE4.1 operates on 128-bit XMM register only. All of these highly encourages software to favor 128-bit vectorizable code to take advantage of processors based on Enhanced Intel Core microarchitecture and Intel Core microarchitecture.

6.8.1.2 Work-around for False Dependency Issue

In processor based on Nehalem microarchitecture, using the PMOVSB and PMOVZB instructions to combine data type conversion and data movement in the same instruction will create a false-dependency due to hardware causes. A simple workaround to avoid the false dependency issue is to use the PMOVSB and PMOVZB instructions solely for data type conversion and issue a separate instruction to move data to destination or from origin.

Example 6-40. PMOVSB/PMOVZB Work-around to Avoid False Dependency

```
#issuing the instruction below will create a false dependency on xmm0
    pmovzxbd xmm0, dword ptr [eax]
// the above instruction may be blocked if xmm0 are updated by other instructions in flight
.....

#Alternate solution to avoid false dependency
    movd xmm0, dword ptr [eax] ; OOO hardware can hoist loads to hide latency
    pmovsxbd xmm0, xmm0
```

6.9 TUNING PARTIALLY VECTORIZABLE CODE

Some loop structured code are more difficult to vectorize than others. Example 6-41 depicts a loop carrying out table look-up operation and some arithmetic computation.

Example 6-41. Table Look-up Operations in C Code

```
// pIn1    integer input arrays.
// pOut    integer output array.
// count   size of array.
// LookUpTable  integer values.
TABLE_SIZE  size of the look-up table.
for (unsigned i=0; i < count; i++)
{
    pOut[i] =
        (( LookUpTable[pIn1[i] % TABLE_SIZE] + pIn1[i] + 17 ) | 17
        ) % 256;
}
}
```

Although some of the arithmetic computations and input/output to data array in each iteration can be easily vectorizable, but the table look-up via an index array is not. This creates different approaches to

tuning. A compiler can take a scalar approach to execute each iteration sequentially. Hand-tuning of such loops may use a couple of different techniques to handle the non-vectorizable table look-up operation. One vectorization technique is to load the input data for four iteration at once, then use SSE2 instruction to shift out individual index out of an XMM register to carry out table look-up sequentially. The shift technique is depicted by Example 6-42. Another technique is to use PEXTRD in SSE4.1 to extract the index from an XMM directly and then carry out table look-up sequentially. The PEXTRD technique is depicted by Example 6-43.

Example 6-42. Shift Techniques on Non-Vectorizable Table Look-up

```

int modulo[4] = {256-1, 256-1, 256-1, 256-1};
int c[4] = {17, 17, 17, 17};
    mov     esi, pln1
    mov     ebx, pOut
    mov     ecx, count
    mov     edx, pLookUpTablePTR
    movaps  xmm6, modulo
    movaps  xmm5, c
loop:
// vectorizable multiple consecutive data accesses
    movaps  xmm4, [esi]      // read 4 indices from pln1
    movaps  xmm7, xmm4
    pand    xmm7, tableSize
//Table look-up is not vectorizable, shift out one data element to look up table one by one
    movd    eax, xmm7        // get first index
    movd    xmm0, word ptr[edx + eax*4]
    psrldq  xmm7, 4
    movd    eax, xmm7        // get 2nd index
    movd    xmm1, word ptr[edx + eax*4]
    psrldq  xmm7, 4
    movd    eax, xmm7        // get 3rd index
    movd    xmm2, word ptr[edx + eax*4]
    psrldq  xmm7, 4
    movd    eax, xmm7        // get fourth index
    movd    xmm3, word ptr[edx + eax*4]
//end of scalar part
//packing
    movlhps xmm1, xmm3
    psllq   xmm1, 32
    movlhps xmm0, xmm2
    orps    xmm0, xmm1
//end of packing
                                                    (continue)

//Vectorizable computation operations
    paddd   xmm0, xmm4 //+pln1
    paddd   xmm0, xmm5 // +17
    por     xmm0, xmm5
    andps   xmm0, xmm6 //mod
    movaps  [ebx], xmm0
//end of vectorizable operation

```

Example 6-42. Shift Techniques on Non-Vectorizable Table Look-up (Contd.)

```

add     ebx, 16
add     esi, 16
add     edi, 16
sub     ecx, 1
test    ecx, ecx
jne     lloop

```

Example 6-43. PEXTRD Techniques on Non-Vectorizable Table Look-up

```

int modulo[4] = {256-1, 256-1, 256-1, 256-1};
int c[4] = {17, 17, 17, 17};
mov     esi, pln1
mov     ebx, pOut
mov     ecx, count
mov     edx, pLookUpTablePTR
movaps  xmm6, modulo
movaps  xmm5, c
lloop:
// vectorizable multiple consecutive data accesses
movaps  xmm4, [esi]    // read 4 indices from pln1
movaps  xmm7, xmm4
pand    xmm7, tableSize
//Table look-up is not vectorizable, extract one data element to look up table one by one
movd    eax, xmm7    // get first index
mov     eax, [edx + eax*4]
movd    xmm0, eax

pextrd  eax, xmm7, 1    // extract 2nd index
mov     eax, [edx + eax*4]
pinsrd  xmm0, eax, 1
pextrd  eax, xmm7, 2    // extract 2nd index
mov     eax, [edx + eax*4]
pinsrd  xmm0, eax, 2
pextrd  eax, xmm7, 3    // extract 2nd index
mov     eax, [edx + eax*4]
pinsrd  xmm0, eax, 2
//end of scalar part
//packing not needed
//Vectorizable operations
padd    xmm0, xmm4 //+pln1
padd    xmm0, xmm5 // +17
por     xmm0, xmm5
andps   xmm0, xmm6 //mod
movaps  [ebx], xmm0
add     ebx, 16
add     esi, 16
add     edi, 16
sub     ecx, 1
test    ecx, ecx
jne     lloop

```

The effectiveness of these two hand-tuning techniques on partially vectorizable code depends on the relative cost of transforming data layout format using various forms of pack and unpack instructions.

The shift technique requires additional instructions to pack scalar table values into an XMM to transition into vectorized arithmetic computations. The net performance gain or loss of this technique will vary with the characteristics of different microarchitectures. The alternate PEXTRD technique uses less instruction to extract each index, does not require extraneous packing of scalar data into packed SIMD data format to begin vectorized arithmetic computation.

6.10 PARALLEL MODE AES ENCRYPTION AND DECRYPTION

To deliver optimal encryption and decryption throughput using AESNI, software can optimize by re-ordering the computations and working on multiple blocks in parallel. This can speed up encryption (and decryption) in parallel modes of operation such as ECB, CTR, and CBC-Decrypt (comparing to CBC-Encrypt which is serial mode of operation). See details in Recommendation for Block Cipher Modes of Operation?. The Related Documentation section provides a pointer to this document.

In Sandy Bridge microarchitecture, the AES round instructions (AESENC / AESECNLAST / AESDEC / AESDECLAST) have a throughput of one cycle and latency of eight cycles. This allows independent AES instructions for multiple blocks to be dispatched every cycle, if data can be provided sufficiently fast. Compared to the prior Westmere microarchitecture, where these instructions have throughput of two cycles and a latency of six cycles, the AES encryption/decryption throughput can be significantly increased for parallel modes of operation.

To achieve optimal parallel operation with multiple blocks, write the AES software sequences in a way that it computes one AES round on multiple blocks, using one Round Key, and then it continues to compute the subsequent round for multiple blocks, using another Round Key.

For such software optimization, you need to define the number of blocks that are processed in parallel. In Sandy Bridge microarchitecture, the optimal parallelization parameter is eight blocks, compared to four blocks on prior microarchitecture.

6.10.1 AES Counter Mode of Operation

Example 6-44 is an example of a function that implements the Counter Mode (CTR mode) of operations while operating on eight blocks in parallel. The following pseudo-code encrypts n data blocks of 16 byte each (PT[i]):

Example 6-44. Pseudo-Code Flow of AES Counter Mode Operation

```

CTRBLK := NONCE || IV || ONE
FOR i := 1 to n-1 DO
    CT[i] := PT[i] XOR AES(CTRBLK)
    CTRBLK := CTRBLK + 1) % 256;
END
CT[n] := PT[n] XOR TRUNC(AES(CTRBLK)) CTRBLK := NONCE || IV || ONE
FOR i := 1 to n-1 DO
    CT[i] := PT[i] XOR AES(CTRBLK)// CT [i] is the i-th ciphertext block
    CTRBLK := CTRBLK + 1
END
CT[n] := PT[n] XOR TRUNC(AES(CTRBLK))

```

Example 6-45 in the following pages show the assembly implementation of the above code, optimized for Sandy Bridge microarchitecture.

Example 6-45. AES128-CTR Implementation with Eight Block in Parallel

```

/*****
/* This function encrypts an input buffer using AES in CTR mode      */
/* The parameters:                                                */
/*  const unsigned char *in - pointer to the plaintext for encryption or */
/*  ciphertext for decryption                                     */
/*  unsigned char *out - pointer to the buffer where the encrypted/decrypted*/
/*                      data will be stored                      */
/*  const unsigned char ivec[8] - 8 bytes of the initialization vector */
/*  const unsigned char nonce[4] - 4 bytes of the nonce             */
/*  const unsigned long length - the length of the input in bytes   */
/*  int number_of_rounds - number of AES round. 10 = AES128, 12 = AES192, 14 = AES256 */
/*  unsigned char *key_schedule - pointer to the AES key schedule   */
*****/
//void AES_128_CTR_encrypt_parallelize_8_blocks_unrolled (
//      const unsigned char *in,
//      unsigned char *out,
//      const unsigned char ivec[8],
//      const unsigned char nonce[4],
//      const unsigned long length,
//      unsigned char *key_schedule)
.align 16,0x90
.align 16
ONE:          .quad 0x00000000,0x00000001
.align 16
FOUR:         .quad 0x00000004,0x00000004
.align 16
EIGHT:        .quad 0x00000008,0x00000008
                                     (continue)

.align 16
TWO_N_ONE:   .quad 0x00000002,0x00000001
.align 16
TWO_N_TWO:   .quad 0x00000002,0x00000002
.align 16
LOAD_HIGH_BROADCAST_AND_BSWAP: .byte 15,14,13,12,11,10,9,8
                                     .byte 15,14,13,12,11,10,9,8

align 16
BSWAP_EPI_64: .byte 7,6,5,4,3,2,1,0
               .byte 15,14,13,12,11,10,9,8

```

Example 6-45. AES128-CTR Implementation with Eight Block in Parallel (Contd.)

```

.globl AES_CTR_encrypt

AES_CTR_encrypt:
# parameter 1: %rdi      # parameter 2: %rsi
# parameter 3: %rdx      # parameter 4: %rcx
# parameter 5: %r8       # parameter 6: %r9
# parameter 7: 8 + %rsp
movq  %r8, %r10
    movl  8(%rsp), %r12d
    shrq  $4, %r8
    shlq  $60, %r10
    je    NO_PARTS
    addq  $1, %r8
NO_PARTS:
    movq  %r8, %r10
    shlq  $61, %r10
    shrq  $61, %r10

    pinsrq $1, (%rdx), %xmm0
    pinsrd $1, (%rcx), %xmm0
    psrldq $4, %xmm0
    movdqa %xmm0, %xmm4
    pshufb (LOAD_HIGH_BROADCAST_AND_BSWAP), %xmm4
    paddq  (TWO_N_ONE), %xmm4
    movdqa %xmm4, %xmm1
    paddq  (TWO_N_TWO), %xmm4
    movdqa %xmm4, %xmm2
    paddq  (TWO_N_TWO), %xmm4
    movdqa %xmm4, %xmm3
    paddq  (TWO_N_TWO), %xmm4
    pshufb (BSWAP_EPI_64), %xmm1
    pshufb (BSWAP_EPI_64), %xmm2
    pshufb (BSWAP_EPI_64), %xmm3
    pshufb (BSWAP_EPI_64), %xmm4

    shrq  $3, %r8
    je    REMAINDER
    subq  $128, %rsi
    subq  $128, %rdi

```

(continue)

Example 6-45. AES128-CTR Implementation with Eight Block in Parallel (Contd.)

```

LOOP:
  addq  $128,%rsi
  addq  $128,%rdi

  movdqa %xmm0,%xmm7
  movdqa %xmm0,%xmm8
  movdqa %xmm0,%xmm9
  movdqa %xmm0,%xmm10
  movdqa %xmm0,%xmm11
  movdqa %xmm0,%xmm12
  movdqa %xmm0,%xmm13
  movdqa %xmm0,%xmm14

  shufpd $2,%xmm1,%xmm7
  shufpd $0,%xmm1,%xmm8
  shufpd $2,%xmm2,%xmm9
  shufpd $0,%xmm2,%xmm10
  shufpd $2,%xmm3,%xmm11
  shufpd $0,%xmm3,%xmm12
  shufpd $2,%xmm4,%xmm13
  shufpd $0,%xmm4,%xmm14

  pshufb (BSWAP_EPL_64),%xmm1
  pshufb (BSWAP_EPL_64),%xmm2
  pshufb (BSWAP_EPL_64),%xmm3
  pshufb (BSWAP_EPL_64),%xmm4

  movdqa (%r9),%xmm5
  movdqa 16(%r9),%xmm6

  paddq (EIGHT),%xmm1
  paddq (EIGHT),%xmm2
  paddq (EIGHT),%xmm3
  paddq (EIGHT),%xmm4

  pxor  %xmm5,%xmm7
  pxor  %xmm5,%xmm8
  pxor  %xmm5,%xmm9
  pxor  %xmm5,%xmm10

  pxor  %xmm5,%xmm11
  pxor  %xmm5,%xmm12
  pxor  %xmm5,%xmm13
  pxor  %xmm5,%xmm14

  pshufb (BSWAP_EPL_64),%xmm1
  pshufb (BSWAP_EPL_64),%xmm2
  pshufb (BSWAP_EPL_64),%xmm3
  pshufb (BSWAP_EPL_64),%xmm4

```

(continue)

Example 6-45. AES128-CTR Implementation with Eight Block in Parallel (Contd.)

```

aesenc  %xmm6, %xmm7
aesenc  %xmm6, %xmm8
aesenc  %xmm6, %xmm9
aesenc  %xmm6, %xmm10
aesenc  %xmm6, %xmm11
aesenc  %xmm6, %xmm12
aesenc  %xmm6, %xmm13
aesenc  %xmm6, %xmm14

movdqa  32(%r9), %xmm5
movdqa  48(%r9), %xmm6

aesenc  %xmm5, %xmm7
aesenc  %xmm5, %xmm8
aesenc  %xmm5, %xmm9
aesenc  %xmm5, %xmm10
aesenc  %xmm5, %xmm11
aesenc  %xmm5, %xmm12
aesenc  %xmm5, %xmm13
aesenc  %xmm5, %xmm14

aesenc  %xmm6, %xmm7
aesenc  %xmm6, %xmm8
aesenc  %xmm6, %xmm9
aesenc  %xmm6, %xmm10
aesenc  %xmm6, %xmm11
aesenc  %xmm6, %xmm12
aesenc  %xmm6, %xmm13
aesenc  %xmm6, %xmm14

movdqa  64(%r9), %xmm5
movdqa  80(%r9), %xmm6

aesenc  %xmm5, %xmm7
aesenc  %xmm5, %xmm8
aesenc  %xmm5, %xmm9
aesenc  %xmm5, %xmm10
aesenc  %xmm5, %xmm11
aesenc  %xmm5, %xmm12
aesenc  %xmm5, %xmm13
aesenc  %xmm5, %xmm14

aesenc  %xmm6, %xmm7
aesenc  %xmm6, %xmm8
aesenc  %xmm6, %xmm9
aesenc  %xmm6, %xmm10
aesenc  %xmm6, %xmm11
aesenc  %xmm6, %xmm12
aesenc  %xmm6, %xmm13
aesenc  %xmm6, %xmm14

```

(continue)

Example 6-45. AES128-CTR Implementation with Eight Block in Parallel (Contd.)

```

movdqa 96(%r9), %xmm5
movdqa 112(%r9), %xmm6

aesenc %xmm5, %xmm7
aesenc %xmm5, %xmm8
aesenc %xmm5, %xmm9
aesenc %xmm5, %xmm10
aesenc %xmm5, %xmm11
aesenc %xmm5, %xmm12
aesenc %xmm5, %xmm13
aesenc %xmm5, %xmm14

aesenc %xmm6, %xmm7
aesenc %xmm6, %xmm8
aesenc %xmm6, %xmm9
aesenc %xmm6, %xmm10
aesenc %xmm6, %xmm11
aesenc %xmm6, %xmm12
aesenc %xmm6, %xmm13
aesenc %xmm6, %xmm14

movdqa 128(%r9), %xmm5
movdqa 144(%r9), %xmm6
movdqa 160(%r9), %xmm15
cmp    $12, %r12d

aesenc %xmm5, %xmm7
aesenc %xmm5, %xmm8
aesenc %xmm5, %xmm9
aesenc %xmm5, %xmm10
aesenc %xmm5, %xmm11
aesenc %xmm5, %xmm12
aesenc %xmm5, %xmm13
aesenc %xmm5, %xmm14

aesenc %xmm6, %xmm7
aesenc %xmm6, %xmm8
aesenc %xmm6, %xmm9
aesenc %xmm6, %xmm10
aesenc %xmm6, %xmm11
aesenc %xmm6, %xmm12
aesenc %xmm6, %xmm13
aesenc %xmm6, %xmm14

jb    LAST

```

(continue)

Example 6-45. AES128-CTR Implementation with Eight Block in Parallel (Contd.)

```

movdqa 160(%r9), %xmm5
movdqa 176(%r9), %xmm6
movdqa 192(%r9), %xmm15
cmp    $14, %r12d

```

```

aesenc %xmm5, %xmm7
aesenc %xmm5, %xmm8
aesenc %xmm5, %xmm9
aesenc %xmm5, %xmm10
aesenc %xmm5, %xmm11
aesenc %xmm5, %xmm12
aesenc %xmm5, %xmm13
aesenc %xmm5, %xmm14

```

```

aesenc %xmm6, %xmm7
aesenc %xmm6, %xmm8
aesenc %xmm6, %xmm9
aesenc %xmm6, %xmm10
aesenc %xmm6, %xmm11
aesenc %xmm6, %xmm12
aesenc %xmm6, %xmm13
aesenc %xmm6, %xmm14

```

```

jb    LAST

```

```

movdqa 192(%r9), %xmm5
movdqa 208(%r9), %xmm6
movdqa 224(%r9), %xmm15

```

```

aesenc %xmm5, %xmm7
aesenc %xmm5, %xmm8
aesenc %xmm5, %xmm9
aesenc %xmm5, %xmm10
aesenc %xmm5, %xmm11
aesenc %xmm5, %xmm12
aesenc %xmm5, %xmm13
aesenc %xmm5, %xmm14

```

```

aesenc %xmm6, %xmm7
aesenc %xmm6, %xmm8
aesenc %xmm6, %xmm9
aesenc %xmm6, %xmm10
aesenc %xmm6, %xmm11
aesenc %xmm6, %xmm12
aesenc %xmm6, %xmm13
aesenc %xmm6, %xmm14

```

LAST:

(continue)

Example 6-45. AES128-CTR Implementation with Eight Block in Parallel (Contd.)

```

aesencast %xmm15, %xmm7
aesencast %xmm15, %xmm8
aesencast %xmm15, %xmm9
aesencast %xmm15, %xmm10
aesencast %xmm15, %xmm11
aesencast %xmm15, %xmm12

aesencast %xmm15, %xmm13
aesencast %xmm15, %xmm14

```

```

pxor (%rdi), %xmm7
pxor 16(%rdi), %xmm8
pxor 32(%rdi), %xmm9
pxor 48(%rdi), %xmm10
pxor 64(%rdi), %xmm11
pxor 80(%rdi), %xmm12
pxor 96(%rdi), %xmm13
pxor 112(%rdi), %xmm14

```

```
dec %r8
```

```

movdqu %xmm7, (%rsi)
movdqu %xmm8, 16(%rsi)
movdqu %xmm9, 32(%rsi)
movdqu %xmm10, 48(%rsi)
movdqu %xmm11, 64(%rsi)
movdqu %xmm12, 80(%rsi)
movdqu %xmm13, 96(%rsi)
movdqu %xmm14, 112(%rsi)
jne LOOP

```

```

addq $128,%rsi
addq $128,%rdi

```

REMAINDER:

```

cmp $0, %r10
je END
shufpd $2, %xmm1, %xmm0

```

IN_LOOP:

```

movdqa %xmm0, %xmm11
pshufb (BSWAP_EPI_64), %xmm0
pxor (%r9), %xmm11
paddq (ONE), %xmm0
aesenc 16(%r9), %xmm11
aesenc 32(%r9), %xmm11
pshufb (BSWAP_EPI_64), %xmm0

```

(continue)

Example 6-45. AES128-CTR Implementation with Eight Block in Parallel (Contd.)

```

aesenc 48(%r9), %xmm11
aesenc 64(%r9), %xmm11
aesenc 80(%r9), %xmm11
aesenc 96(%r9), %xmm11
aesenc 112(%r9), %xmm11
aesenc 128(%r9), %xmm11
aesenc 144(%r9), %xmm11
movdqa 160(%r9), %xmm2
cmp $12, %r12d
jb IN_LAST
aesenc 160(%r9), %xmm11
aesenc 176(%r9), %xmm11
movdqa 192(%r9), %xmm2
cmp $14, %r12d
jb IN_LAST
aesenc 192(%r9), %xmm11
aesenc 208(%r9), %xmm11
movdqa 224(%r9), %xmm2
IN_LAST:
aesenclast %xmm2, %xmm11
pxor (%rdi), %xmm11
movdqu %xmm11, (%rsi)
addq $16, %rdi
addq $16, %rsi
dec %r10
jne IN_LOOP
END:
ret

```

6.10.2 AES Key Expansion Alternative

In Sandy Bridge microarchitecture, the throughput of AESKEYGENASSIST is two cycles with higher latency than the AESENC/AESDEC instructions. Software may consider implementing the AES key expansion by using the AESENCLAST instruction with the second operand (i.e., the round key) being the RCON value, duplicated four times in the register. The AESENCLAST instruction performs the SubBytes step and the xor-with-RCON step, while the ROTWORD step can be done using a PSHUFB instruction. Following are code examples of AES128 key expansion using either method.

Example 6-46. AES128 Key Expansion

<pre> // Use AESKEYGENASSIST .align 16,0x90 .globl AES_128_Key_Expansion AES_128_Key_Expansion: # parameter 1: %rdi # parameter 2: %rsi movl \$10, 240(%rsi) movdqu (%rdi), %xmm1 movdqa %xmm1, (%rsi) </pre> <p style="text-align: right;">(continue)</p>	<pre> // Use AESENCLAST mask: .long 0x0c0f0e0d,0x0c0f0e0d,0x0c0f0e0d,0x0c0f0e0d con1: .long 1,1,1,1 con2: .long 0x1b,0x1b,0x1b,0x1b .align 16,0x90 .globl AES_128_Key_Expansion </pre> <p style="text-align: right;">(continue)</p>
--	---

Example 6-46. AES128 Key Expansion (Contd.)

<pre> aeskeygenassist \$1, %xmm1, %xmm2 call PREPARE_ROUNDKEY_128 movdqa %xmm1, 16(%rsi) aeskeygenassist \$2, %xmm1, %xmm2 call PREPARE_ROUNDKEY_128 movdqa %xmm1, 32(%rsi) aeskeygenassist \$4, %xmm1, %xmm2 ASSISTS: call PREPARE_ROUNDKEY_128 movdqa %xmm1, 48(%rsi) aeskeygenassist \$8, %xmm1, %xmm2 call PREPARE_ROUNDKEY_128 movdqa %xmm1, 64(%rsi) aeskeygenassist \$16, %xmm1, %xmm2 call PREPARE_ROUNDKEY_128 movdqa %xmm1, 80(%rsi) aeskeygenassist \$32, %xmm1, %xmm2 call PREPARE_ROUNDKEY_128 movdqa %xmm1, 96(%rsi) aeskeygenassist \$64, %xmm1, %xmm2 call PREPARE_ROUNDKEY_128 movdqa %xmm1, 112(%rsi) aeskeygenassist \$0x80, %xmm1, %xmm2 call PREPARE_ROUNDKEY_128 movdqa %xmm1, 128(%rsi) aeskeygenassist \$0x1b, %xmm1, %xmm2 call PREPARE_ROUNDKEY_128 movdqa %xmm1, 144(%rsi) aeskeygenassist \$0x36, %xmm1, %xmm2 call PREPARE_ROUNDKEY_128 movdqa %xmm1, 160(%rsi) ret PREPARE_ROUNDKEY_128: pshufd \$255, %xmm2, %xmm2 movdqa %xmm1, %xmm3 pslldq \$4, %xmm3 pxor %xmm3, %xmm1 pslldq \$4, %xmm3 pxor %xmm3, %xmm1 pslldq \$4, %xmm3 pxor %xmm3, %xmm1 pxor %xmm2, %xmm1 ret </pre>	<pre> AES_128_Key_Expansion: # parameter 1: %rdi # parameter 2: %rsi movdqu (%rdi), %xmm1 movdqa %xmm1, (%rsi) movdqa %xmm1, %xmm2 movdqa (con1), %xmm0 movdqa (mask), %xmm15 mov \$8, %ax LOOP1: add \$16, %rsi dec %ax pshufb %xmm15, %xmm2 aesenc128 %xmm0, %xmm2 pslld \$1, %xmm0 movdqa %xmm1, %xmm3 pslldq \$4, %xmm3 pxor %xmm3, %xmm1 pslldq \$4, %xmm3 pxor %xmm3, %xmm1 pslldq \$4, %xmm3 pxor %xmm3, %xmm1 pxor %xmm2, %xmm1 movdqa %xmm1, (%rsi) movdqa %xmm1, %xmm2 jne LOOP1 movdqa (con2), %xmm0 pshufb %xmm15, %xmm2 aesenc128 %xmm0, %xmm2 pslld \$1, %xmm0 movdqa %xmm1, %xmm3 pslldq \$4, %xmm3 pxor %xmm3, %xmm1 pslldq \$4, %xmm3 pxor %xmm3, %xmm1 pslldq \$4, %xmm3 pxor %xmm3, %xmm1 pxor %xmm2, %xmm1 movdqa %xmm1, 16(%rsi) movdqa %xmm1, %xmm2 pshufb %xmm15, %xmm2 aesenc128 %xmm0, %xmm2 movdqa %xmm1, %xmm3 pslldq \$4, %xmm3 pxor %xmm3, %xmm1 pslldq \$4, %xmm3 pxor %xmm3, %xmm1 (continue) </pre>
--	--

Example 6-46. AES128 Key Expansion (Contd.)

	<pre>pslldq \$4, %xmm3 pxor %xmm3, %xmm1 pxor %xmm2, %xmm1 movdqa %xmm1, 32(%rsi) movdqa %xmm1, %xmm2 ret</pre>
--	---

6.10.3 Enhancement in Haswell Microarchitecture**6.10.3.1 AES and Multi-Buffer Cryptographic Throughput**

The AESINC/AESINCLAST, AESDEC/AESDECLAST instructions in Haswell microarchitecture have slightly improved latency, and are one micro-op. These improvements are expected to benefit AES algorithms operating in parallel modes (e.g., CBC decryption) and multiple-buffer implementations of AES algorithms. See the following link for additional details on AESNI:

- <http://software.intel.com/en-us/articles/intel-advanced-encryption-standard-aes-instructions-set>.

6.10.3.2 PCLMULQDQ Improvement

The latency of PCLMULQDQ in Haswell microarchitecture is reduced from 14 to 7 cycles, and throughput improved from once every 8 cycles to every other cycle, when compared to prior generations. This will speed up CRC calculations for generic polynomials. Details and examples can be found at:

- <http://www.intel.com/Assets/PDF/manual/323640.pdf>.

AES-GCM implemented using PCLMULQDQ can be found in OpenSSL project at:

- <http://www.intel.com/content/dam/www/public/us/en/documents/software-support/enabling-high-performance-gcm.pdf>.

6.11 LIGHT-WEIGHT DECOMPRESSION AND DATABASE PROCESSING

Traditionally, database storage requires high-compression ratio means to preserve the finite disk I/O bandwidth limitations. In row-optimized database architecture, the primary limitation on database processing performance often correlates to the hardware constraints of the storage I/O bandwidth, the locality issues of data records from rows in large tables that must be decompressed from its storage format. Many recent database innovations are centered around columnar database architecture, where storage format is optimized for query operations to fetch data in a sequential manner.

Some of the recent advances in columnar database (also known as in-memory database) are light-weight compression/decompression techniques and vectorized query operation primitives using SSE4.2 and other SIMD instructions. When a database engine combines those processing techniques with a column-optimized storage system using solid state drives, query performance increase of several fold has been reported¹. This section discusses the usage of SIMD instructions for light-weight compression/decompression in columnar databases.

The optimal objective for light-weight compression/decompression is to deliver high throughput at reasonably low CPU utilization, such that the finite total compute bandwidth can be divided more favorably between query processing and decompression to achieve maximal query throughput. SSE4.2 can raise the compute bandwidth for some query operations to a significantly higher level (see Section 14.3.3), compared to query primitives implemented using general-purpose-register instructions. This also places higher demand on the streaming data feed of decompressed columnar data.

1. See published TPC-H non-clustered performance results at www.tpc.org

6.11.1 Reduced Dynamic Range Datasets

One of the more successful approaches to compress/decompress columnar data in high-speed is based on the idea that an ensemble of integral values in a sequential data stream of fixed-size storage width can be represented more compactly if the dynamic range of that ensemble is reduced by way of partitioning, offset from a common reference value, and additional techniques^{1,2}.

For example, a column that stores 5-digit ZIPCODE as 32-bit integers only requires a dynamic range of 17 bits. The unique primary keys in a 2 billion row table can be reduced through partitioning of sequential blocks of 2^N entries to store the offset in the block header and reducing the storage size of each 32-bit integer as N bits.

6.11.2 Compression and Decompression Using SIMD Instructions

To illustrate the usage of SIMD instructions for reduced-dynamic-range compression/decompression, and compressed data elements are not byte-aligned, we consider an array of 32-bit integers whose dynamic range only requires 5 bits per value.

To pack a stream of 32-bit integer values into consecutive 5-bit buckets, the SIMD technique illustrated in Example 6-47 consists of the following phases:

- Dword-to-byte packing and byte-array sequencing: The stream of dword elements is reduced to byte streams with each iteration handling 32 elements. The two resulting 16-byte vectors are sequenced to enable 4-way bit-stitching using PSLLD and PSRLD instructions.

Example 6-47. Compress 32-bit Integers into 5-bit Buckets

```

;
static __declspec(align(16)) short mask_dw_5b[16] = // 5-bit mask for 4 way bit-packing via dword
{0x1f, 0x0, 0x1f, 0x0, 0x1f, 0x0, 0x1f, 0x0}; // packed shift
static __declspec(align(16)) short sprdb_0_5_10_15[8] = // shuffle control to re-arrange
{ 0xff00, 0xffff, 0x04ff, 0xffff, 0xffff, 0xff08, 0xffff, 0x0cff}; // bytes 0, 4, 8, 12 to gap positions at 0, 5, 10, 15

void RDRpack32x4_sse(int *src, int cnt, char * out)

int i, j;
__m128i a0, a1, a2, a3, c0, c1, b0, b1, b2, b3, bb;
__m128i msk4;
__m128i sprd4 = _mm_loadu_si128( (__m128i*) &sprdb_0_5_10_15[0]);
switch( bucket_width) {
case 5:j= 0;
        (continue)

```

1. "SIMD-scan: ultra fast in-memory table scan using on-chip vector processing units", T. Willhalm, et. al., Proceedings of the VLDB Endowment, Vol. 2, #1, August 2009.

2. "Super-Scalar RAM-CPU Cache Compression," M. Zukowski, et, al, Data Engineering, International Conference, vol. 0, no. 0, pp. 59, 2006.

Example 6-47. Compress 32-bit Integers into 5-bit Buckets (Contd.)

```

msk4 = _mm_loadu_si128( (__m128i*) &mask_dw_5b[0]);
// process 32 elements in each iteration
for (i = 0; i < cnt; i+= 32) {
    b0 = _mm_packus_epi32(_mm_loadu_si128( (__m128i*) &src[i]), _mm_loadu_si128( (__m128i*) &src[i+4]));
    b1 = _mm_packus_epi32(_mm_loadu_si128( (__m128i*) &src[i+8]), _mm_loadu_si128( (__m128i*) &src[i+12]));
    b2 = _mm_packus_epi32(_mm_loadu_si128( (__m128i*) &src[i+16]), _mm_loadu_si128( (__m128i*)
&src[i+20]));
    b3 = _mm_packus_epi32(_mm_loadu_si128( (__m128i*) &src[i+24]), _mm_loadu_si128( (__m128i*)
&src[i+28]));
    c0 = _mm_packus_epi16( _mm_unpacklo_epi64(b0, b1), _mm_unpacklo_epi64(b2, b3));
    // c0 contains bytes: 0-3, 8-11, 16-19, 24-27 elements
    c1 = _mm_packus_epi16( _mm_unpackhi_epi64(b0, b1), _mm_unpackhi_epi64(b2, b3));
    // c1 contains bytes: 4-7, 12-15, 20-23, 28-31

    b0 = _mm_and_si128( c0, msk4);           // keep lowest 5 bits in each way/dword
    b1 = _mm_and_si128( _mm_srli_epi32(c0, 3), _mm_slli_epi32(msk4, 5));
    b0 = _mm_or_si128( b0, b1);             // add next 5 bits to each way/dword
    b1 = _mm_and_si128( _mm_srli_epi32(c0, 6), _mm_slli_epi32(msk4, 10));
    b0 = _mm_or_si128( b0, b1);
    b1 = _mm_and_si128( _mm_srli_epi32(c0, 9), _mm_slli_epi32(msk4, 15));
    b0 = _mm_or_si128( b0, b1);
    b1 = _mm_and_si128( _mm_slli_epi32(c1, 20), _mm_slli_epi32(msk4, 20));
    b0 = _mm_or_si128( b0, b1);
    b1 = _mm_and_si128( _mm_slli_epi32(c1, 17), _mm_slli_epi32(msk4, 25));
    b0 = _mm_or_si128( b0, b1);
    b1 = _mm_and_si128( _mm_slli_epi32(c1, 14), _mm_slli_epi32(msk4, 30));
    b0 = _mm_or_si128( b0, b1);           // add next 2 bits from each dword channel, xmm full
    *(int*)&out[j] = _mm_cvtsi128_si32( b0); // the first dword is compressed and ready
    // re-distribute the remaining 3 dword and add gap bytes to store remained bits
    b0 = _mm_shuffle_epi8(b0, gap4x3);
    b1 = _mm_and_si128( _mm_srli_epi32(c1, 18), _mm_srli_epi32(msk4, 2)); // do 4-way packing of the next 3 bits
    b2 = _mm_and_si128( _mm_srli_epi32(c1, 21), _mm_slli_epi32(msk4, 3));
    b1 = _mm_or_si128( b1, b2); //5th byte compressed at bytes 0, 4, 8, 12
    // shuffle the fifth byte result to byte offsets of 0, 5, 10, 15
    b0 = _mm_or_si128( b0, _mm_shuffle_epi8(b1, sprd4));
    _mm_storeu_si128( (__m128i *) &out[j+4], b0);
    j += bucket_width*4;
}
// handle remainder if cnt is not multiples of 32
break;
}
}

```

- Four-way bit stitching: In each way (dword) of the destination, 5 bits are packed consecutively from the corresponding byte element that contains 5 non-zero bit patterns. Since each dword destination will be completely filled up by the contents of 7 consecutive elements, the remaining three bits of the 7th element and the 8th element are done separately in a similar 4-way stitching operation but require the assistance of shuffle operations.

Example 6-48 shows the reverse operation of decompressing consecutively packed 5-bit buckets into 32-bit data elements.

Example 6-48. Decompression of a Stream of 5-bit Integers into 32-bit Elements

```

;
static __declspec(align(16)) short mask_dw_5b[16] = // 5-bit mask for 4 way bit-packing via dword
{0x1f, 0x0, 0x1f, 0x0, 0x1f, 0x0, 0x1f, 0x0}; // packed shift
static __declspec(align(16)) short pack_dw_4x3[8] = // pack 3 dwords 1-4, 6-9, 11-14
{ 0xffff, 0xffff, 0x0201, 0x0403, 0x0706, 0x0908, 0xc0b, 0x0e0d}; // to vacate bytes 0-3
static __declspec(align(16)) short packb_0_5_10_15[8] = // shuffle control to re-arrange bytes
{ 0xffff, 0x0ff, 0xffff, 0x5ff, 0xffff, 0xaff, 0xffff, 0x0fff}; // 0, 5, 10, 15 to gap positions at 3, 7, 11, 15

void RDRunpack32x4_sse(char *src, int cnt, int * out)
{int i, j;
 __m128i a0, a1, a2, a3, c0, c1, b0, b1, b2, b3, bb, d0, d1, d2, d3;
 __m128i msk4;
 __m128i pck4 = _mm_loadu_si128( (__m128i*) &packb_0_5_10_15[0]);
 __m128i pckdw3 = _mm_loadu_si128( (__m128i*) &pack_dw_4x3[0]);

    switch( bucket_width) {
    case 5:j= 0;
        msk4 = _mm_loadu_si128( (__m128i*) &mask_dw_5b[0]);
        for (i = 0; i < cnt; i+= 32) {
            a1 = _mm_loadu_si128( (__m128i*) &src[j +4]);
            // pick up bytes 4, 9, 14, 19 and shuffle into offset 3, 7, 11, 15
            c0 = _mm_shuffle_epi8(a1, pck4);
            b1 = _mm_and_si128( _mm_srli_epi32(c0, 3), _mm_slli_epi32(msk4, 24));
            // put 3 unaligned dword 1-4, 6-9, 11-14 to vacate bytes 0-3
            a1 = _mm_shuffle_epi8(a1, pckdw3);
            b0 = _mm_and_si128( _mm_srli_epi32(c0, 6), _mm_slli_epi32(msk4, 16));
            a0 = _mm_cvtsi32_si128( *(int *)&src[j]);
            b1 = _mm_or_si128( b0, b1); // finished decompress source bytes 4, 9, 14, 19
            a0 = _mm_or_si128( a0, a1); // bytes 0-16 contain compressed bits
            b0 = _mm_and_si128( _mm_srli_epi32(a0, 14), _mm_slli_epi32(msk4, 16));
            b1 = _mm_or_si128( b0, b1);
            b0 = _mm_and_si128( _mm_srli_epi32(a0, 17), _mm_slli_epi32(msk4, 8));
            b1 = _mm_or_si128( b0, b1);
            b0 = _mm_and_si128( _mm_srli_epi32(a0, 20), msk4);
            b1 = _mm_or_si128( b0, b1); // b1 now full with decompressed 4-7,12-15,20-23,28-31
            _mm_storeu_si128( (__m128i *) &out[j+4], _mm_cvtepu8_epi32(b1));
            b0 = _mm_and_si128( _mm_slli_epi32(a0, 9), _mm_slli_epi32(msk4, 24));
            c0 = _mm_and_si128( _mm_slli_epi32(a0, 6), _mm_slli_epi32(msk4, 16));
            b0 = _mm_or_si128( b0, c0);
            _mm_storeu_si128( (__m128i *) &out[j+12], _mm_cvtepu8_epi32(_mm_srli_si128(b1, 4)));
            c0 = _mm_and_si128( _mm_slli_epi32(a0, 3), _mm_slli_epi32(msk4, 8));
            _mm_storeu_si128( (__m128i *) &out[j+20], _mm_cvtepu8_epi32(_mm_srli_si128(b1, 8)));
            b0 = _mm_or_si128( b0, c0);
            _mm_storeu_si128( (__m128i *) &out[j+28], _mm_cvtepu8_epi32(_mm_srli_si128(b1, 12)));
            c0 = _mm_and_si128( a0, msk4);
            b0 = _mm_or_si128( b0, c0); // b0 now full with decompressed 0-3,8-11,16-19,24-27

```

Example 6-48. Decompression of a Stream of 5-bit Integers into 32-bit Elements (Contd.)

```

    _mm_storeu_si128( (__m128i *) &out[i], _mm_cvtepu8_epi32(b0));
    _mm_storeu_si128( (__m128i *) &out[i+8], _mm_cvtepu8_epi32(_mm_srli_si128(b0, 4)));
    _mm_storeu_si128( (__m128i *) &out[i+16], _mm_cvtepu8_epi32(_mm_srli_si128(b0, 8)));
    _mm_storeu_si128( (__m128i *) &out[i+24], _mm_cvtepu8_epi32(_mm_srli_si128(b0, 12)));
    j += g_bwidth*4;
}
break;
}
}

```

Compression/decompression of integers for dynamic range that are non-power-of-2 can generally use similar mask/packed shift/stitch technique with additional adaptation of the horizontal rearrangement of partially stitched vectors. The increase in throughput relative to using general-purpose scalar instructions will depend on implementation and bucket width.

When compiled with the "/O2" option on an Intel Compiler, the compression throughput can reach 6 Bytes/cycle on Sandy Bridge microarchitecture, and the throughput varies little for working set sizes due to the streaming data access pattern and the effectiveness of hardware prefetchers. The decompression throughput of the above example is more than 5 Bytes/cycle at full utilization, allowing a database query engine to partition CPU utilization effectively to allocate a small fraction for on-the-fly decompression to feed vectorized query computation.

The decompression throughput increase using a SIMD light-weight compression technique offers database architects new degrees of freedom to relocate critical performance bottlenecks from a lower-throughput technology (disk I/O, DRAM) to a faster pipeline.

CHAPTER 7

OPTIMIZING FOR SIMD FLOATING-POINT APPLICATIONS

This chapter discusses rules for optimizing the single-instruction, multiple-data (SIMD) floating-point instructions available in SSE, SSE2 SSE3, and SSE4.1. The chapter also provides examples illustrating the optimization techniques for single-precision and double-precision SIMD floating-point applications.

7.1 GENERAL RULES FOR SIMD FLOATING-POINT CODE

The rules and suggestions in this section help optimize floating-point code containing SIMD floating-point instructions. Generally, it is essential to understand and balance port utilization to create efficient SIMD floating-point code. Basic rules and suggestions include the following:

- Follow all guidelines in Chapter 3 and Chapter 5.
- Mask exceptions to achieve higher performance. When exceptions are unmasked, software performance is slower.
- Utilize the flush-to-zero and denormals-are-zero modes for higher performance to avoid the penalty of dealing with denormals and underflows.
- Use the reciprocal instructions followed by iteration for increased accuracy. These instructions yield reduced accuracy but execute much faster. Note the following:
 - If reduced accuracy is acceptable, use them with no iteration.
 - If near full accuracy is needed, use a Newton-Raphson iteration.
 - If full accuracy is needed, then use divide and square root, which provide more accuracy, but slow down performance.

7.2 PLANNING CONSIDERATIONS

Whether adapting an existing application or creating a new one, using SIMD floating-point instructions to achieve optimum performance gain requires programmers to consider several issues. When choosing candidates for optimization, look for code segments that are computationally intensive and floating-point intensive. Also, consider efficient use of the cache architecture.

The sections that follow answer the questions that should be raised before implementation:

- Can data layout be arranged to increase parallelism or cache utilization?
- Which part of the code benefits from SIMD floating-point instructions?
- Is the current algorithm the most appropriate for SIMD floating-point instructions?
- Is the code floating-point intensive?
- Do single-precision floating-point or double-precision floating-point computations provide enough range and precision?
- Does the result of computation affected by enabling flush-to-zero or denormals-to-zero modes?
- Is the data arranged for efficient utilization of the SIMD floating-point registers?
- Is this application targeted for processors without SIMD floating-point instructions?

See Section 5.2, "Considerations for Code Conversion to SIMD Programming."

7.3 USING SIMD FLOATING-POINT WITH X87 FLOATING-POINT

Because the XMM registers used for SIMD floating-point computations are separate registers and are not mapped to the existing x87 floating-point stack, SIMD floating-point code can be mixed with x87 floating-point or 64-bit SIMD integer code.

With Intel Core microarchitecture, 128-bit SIMD integer instructions provide substantially higher efficiency than 64-bit SIMD integer instructions. Software should favor using SIMD floating-point and integer SIMD instructions with XMM registers where possible.

7.4 SCALAR FLOATING-POINT CODE

SIMD floating-point instructions operate only on the lowest order element in the SIMD register. These instructions are known as scalar instructions. They allow the XMM registers to be used for general-purpose floating-point computations.

In terms of performance, scalar floating-point code can be equivalent to or exceed x87 floating-point code and has the following advantages:

- SIMD floating-point code uses a flat register model, whereas x87 floating-point code uses a stack model. Using scalar floating-point code eliminates the need to use FXCH instructions. These have performance limits on the Intel Pentium 4 processor.
- Mixing with MMX technology code without penalty.
- Flush-to-zero mode.
- Shorter latencies than x87 floating-point.

When using scalar floating-point instructions, it is unnecessary to ensure that the data appears in vector form. However, the optimizations for alignment, scheduling, instruction selection, and other optimizations covered in Chapter 3 and Chapter 5 should be observed.

7.5 DATA ALIGNMENT

SIMD floating-point data is 16-byte aligned. Referencing unaligned 128-bit SIMD floating-point data will result in an exception unless MOVUPS or MOVUPD (move unaligned packed single or unaligned packed double) is used. The unaligned instructions used on aligned or unaligned data will also suffer a performance penalty relative to aligned accesses.

See also: Section 5.4, "Stack and Data Alignment."

7.5.1 Data Arrangement

Because SSE and SSE2 incorporate SIMD architecture, arranging data to use the SIMD registers fully produces optimum performance. This implies contiguous data for processing, which leads to fewer cache misses. Correct data arrangement can quadruple data throughput using SSE, or double throughput when using SSE2. Performance gains can occur because four data elements can be loaded with 128-bit load instructions into XMM registers using SSE (MOVAPS). Similarly, two data elements can be loaded with 128-bit load instructions into XMM registers using SSE2 (MOVAPD).

Refer to Section 5.4, "Stack and Data Alignment," for data arrangement recommendations. Duplicating and padding techniques overcome misalignment problems that in some data structures and arrangements. This increases the data space but avoids penalties for misaligned data access.

For some applications (3D geometry, for example), traditional data arrangement requires some changes to use the SIMD registers and parallel techniques fully. Traditionally, the data layout has been an array of structures (AoS). A new data layout has been proposed to fully use the SIMD registers in such applications: a structure of arrays (SoA) resulting in more optimized performance.

7.5.1.1 Vertical versus Horizontal Computation

Most floating-point arithmetic instructions in SSE/SSE2 provide a more significant performance gain on vertical data processing for parallel data elements. This means that each element of the destination results from an arithmetic operation performed from the source elements in the same vertical position (Figure 7-1).

To supplement these homogeneous arithmetic operations on parallel data elements, SSE and SSE2 provide data movement instructions (e.g., SHUFPS, UNPCKLPS, UNPCKHPS, MOVLHPS, MOVHLPS, etc.) that facilitate moving data elements horizontally.

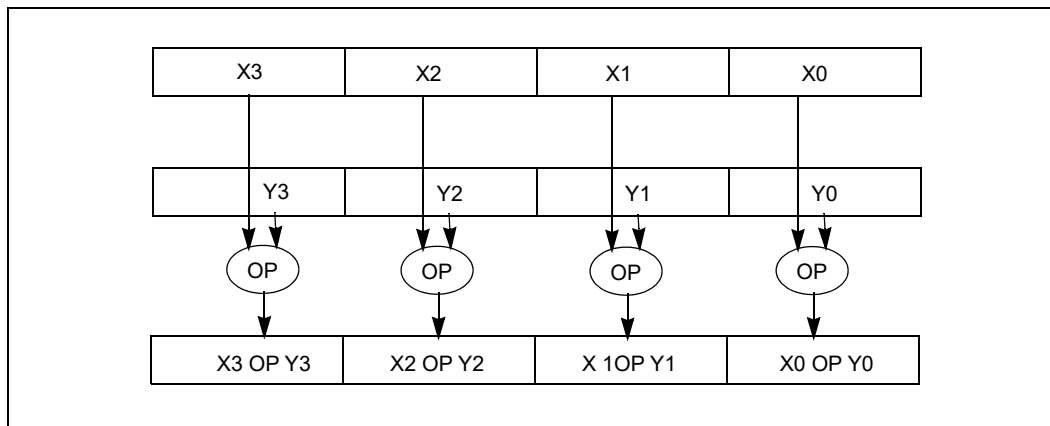

Figure 7-1. Homogeneous Operation on Parallel Data Elements

The organization of structured data significantly impacts SIMD programming efficiency and performance. This can be illustrated using two common type of data structure organizations:

- **Array of Structure (AoS):** This refers to arranging an array of data structures. Within the data structure, each member is a scalar. This is shown in Figure 7-2. Typically, a repetitive computation sequence is applied to each element of an array, i.e., a data structure. The computational sequence for the scalar members of the structure is likely to be non-homogeneous within each iteration. AoS is generally associated with a horizontal computation model.

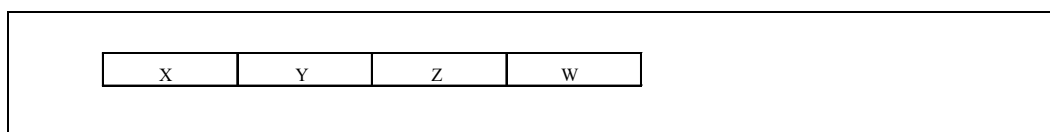

Figure 7-2. Horizontal Computation Model

- **Structure of Array (SoA):** Here, each member of the data structure is an array. Each element of the array is a scalar. This is shown in Table 7-1. The repetitive computational sequence is applied to scalar elements and homogeneous operation can be easily achieved across consecutive iterations within the same structural member. Consequently, SoA is generally amenable to the vertical computation model.

Table 7-1. SoA Form of Representing Vertices Data

Vx array	X1	X2	X3	X4	Xn
Vy array	Y1	Y2	Y3	Y4	Yn
Vz array	Z1	Z2	Z3	Y4	Zn
Vw array	W1	W2	W3	W4	Wn

SIMD instructions with vertical computation on the SoA arrangement can achieve higher efficiency and performance than AoS and horizontal computation. This can be seen with dot-product operation on vectors. The dot product operation on the SoA arrangement is shown in Figure 7-3.

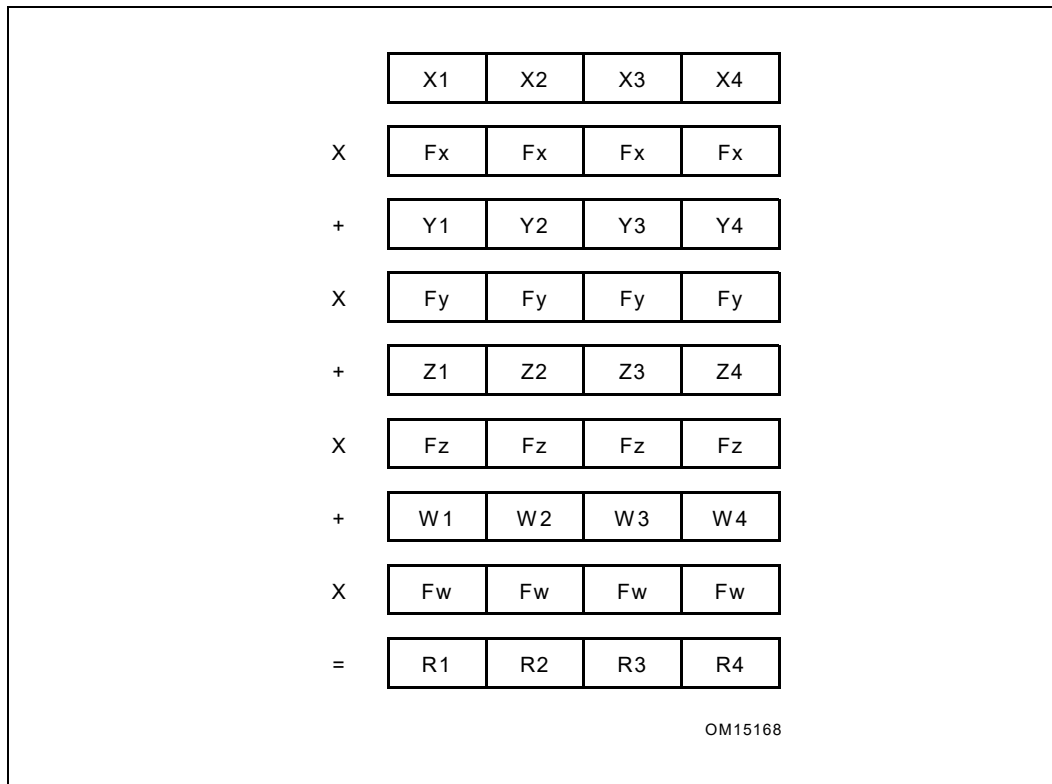

Figure 7-3. Dot Product Operation

Example 7-1 shows how one result would be computed for seven instructions if the data were organized as AoS and using SSE alone: four results would require 28 instructions.

Example 7-1. Pseudocode for Horizontal (xyz, AoS) Computation

```

mulps    ; x*x', y*y', z*z'
movaps   ; reg->reg move, since next steps overwrite
shufps  ; get b,a,d,c from a,b,c,d
addps   ; get a+b,a+b,c+d,c+d
movaps   ; reg->reg move
shufps  ; get c+d,c+d,a+b,a+b from prior addps
addps   ; get a+b+c+d,a+b+c+d,a+b+c+d,a+b+c+d
    
```

Now consider the case when the data is organized as SoA. Example 7-2 demonstrates how four results are computed for five instructions.

Example 7-2. Pseudocode for Vertical (xxxx, yyyy, zzzz, SoA) Computation

```
mulps ; x*x' for all 4 x-components of 4 vertices
mulps ; y*y' for all 4 y-components of 4 vertices
mulps ; z*z' for all 4 z-components of 4 vertices
addps ; x*x' + y*y'
addps ; x*x'+y*y'+z*z'
```

For the most efficient use of the four component-wide registers, reorganizing the data into the SoA format yields increased throughput and hence much better performance for the instructions used.

This simple example shows that vertical computation can yield 100% use of the available SIMD registers to produce four results. Note that results may vary for other situations. Suppose the data structures are represented in a format that is not “friendly” to vertical computation. In that case, it can be rearranged “on the fly” to facilitate better utilization of the SIMD registers. This operation is referred to as a “swizzling” operation. The reverse operation is referred to as “deswizzling.”

7.5.1.2 Data Swizzling

Swizzling data from SoA to AoS format can apply to multiple application domains, including 3D geometry, video and imaging. Two different swizzling techniques can be adapted to handle floating-point and integer data. Example 7-3 illustrates a swizzle function that uses SHUFPS, MOVLHPS, and MOVHLPS instructions.

Example 7-3. Swizzling Data Using SHUFPS, MOVLHPS, MOVHLPS

```
typedef struct _VERTEX_AOS {
    float x, y, z, color;
} Vertex_aos; // AoS structure declaration
typedef struct _VERTEX_SOA {
    float x[4], float y[4], float z[4];
    float color[4];
} Vertex_soa; // SoA structure declaration
void swizzle_asm (Vertex_aos *in, Vertex_soa *out)
{
    // in mem: x1y1z1w1-x2y2z2w2-x3y3z3w3-x4y4z4w4-
    // SWIZZLE XYZW --> XXXX
    asm {
        mov rbx, in // get structure addresses
        mov rdx, out
        movaps xmm1, [rbx] // w0 z0 y0 x0
        movaps xmm2, [rbx + 16] // w1 z1 y1 x1
        movaps xmm3, [rbx + 32] // w2 z2 y2 x2
        movaps xmm4, [rbx + 48] // w3 z3 y2 x3
        movaps xmm7, xmm4 // xmm7= w3 z3 y3 x3
        movhlps xmm7, xmm3 // xmm7= w3 z3 w2 z2
        movaps xmm6, xmm2 // xmm6= w1 z1 y1 x1
        movhlps xmm3, xmm4 // xmm3= y3 x3 y1 x1
        movhlps xmm2, xmm1 // xmm2= w1 z1 w0 z0
        movhlps xmm1, xmm6 // xmm1= y1 x1 y0 x0
```

Example 7-3. Swizzling Data (Contd.)Using SHUFPS, MOVLHPS, MOVHPS (Contd.)

```

movaps xmm6, xmm2           // xmm6= w1 z1 w0 z0
movaps xmm5, xmm1           // xmm5= y1 x1 y0 x0
shufps xmm2, xmm7, 0xDDh    // xmm2= w3 w2 w1 w0 => W
shufps xmm1, xmm3, 0x88h    // xmm1= x3 x2 x1 x0 => X
shufps xmm5, xmm3, 0xDDh    // xmm5= y3 y2 y1 y0 => Y
shufps xmm6, xmm7, 0x88h    // xmm6= z3 z2 z1 z0 => Z

movaps [rdx], xmm1          // store X
movaps [rdx+16], xmm5       // store Y
movaps [rdx+32], xmm6       // store Z
movaps [rdx+48], xmm2       // store W
}
}

```

Example 7-4 shows a similar data-swizzling algorithm using SIMD instructions in the integer domain.

Example 7-4. Swizzling Data Using UNPCKxxx Instructions

```

void swizzle_asm(Vertex_aos *in, Vertex_soa *out)
{
// in mem: x1y1z1w1-x2y2z2w2-x3y3z3w3-x4y4z4w4-
// SWIZZLE XYZW --> XXXX
asm {
    mov rbx, in                // get structure addresses
    mov rdx, out

    movdqa xmm1, [rbx + 0*16] //w0 z0 y0 x0
    movdqa xmm2, [rbx + 1*16] //w1 z1 y1 x1
    movdqa xmm3, [rbx + 2*16] //w2 z2 y2 x2
    movdqa xmm4, [rbx + 3*16] //w3 z3 y3 x3
    movdqa xmm5, xmm1
    punpckldq xmm1, xmm2       // y1 y0 x1 x0
    punpckhdq xmm5, xmm2       // w1 w0 z1 z0
    movdqa xmm2, xmm3
    punpckldq xmm3, xmm4       // y3 y2 x3 x2
    punpckhdq xmm2, xmm4       // w3 w2 z3 z2
    movdqa xmm4, xmm1
    punpcklqdq xmm1, xmm3      // x3 x2 x1 x0
    punpckhqdq xmm4, xmm3      // y3 y2 y1 y0
    movdqa xmm3, xmm5
    punpcklqdq xmm5, xmm2      // z3 z2 z1 z0
    punpckhqdq xmm3, xmm2      // w3 w2 w1 w0

    movdqa [rdx+0*16], xmm1    //x3 x2 x1 x0
    movdqa [rdx+1*16], xmm4    //y3 y2 y1 y0
    movdqa [rdx+2*16], xmm5    //z3 z2 z1 z0
    movdqa [rdx+3*16], xmm3    //w3 w2 w1 w0
}
}

```

The technique in Example 7-3 (loading 16 bytes, using SHUFPS and copying halves of XMM registers) is preferable over an alternate approach of loading halves of each vector using MOVLPS/MOVHPS on newer microarchitectures. This is because loading 8 bytes using MOVLPS/MOVHPS can create code dependency and reduce the throughput of the execution engine.

The performance considerations of Example 7-3, and Example 7-4 often depend on each microarchitecture's characteristics. For example, in Intel Core microarchitecture, executing a SHUFPS tend to be slower than a PUNPCKxxx instruction. In Enhanced Intel Core microarchitecture, SHUFPS and PUNPCKxxx instruction execute with one cycle throughput due to the 128-bit shuffle execution unit. The next important consideration is that only one port can execute PUNPCKxxx rather than MOVLHPS/MOVLHPS executing on multiple ports. The performance of both techniques improves on Intel Core microarchitecture over previous microarchitectures due to 3 ports for executing SIMD instructions. Both techniques further improve the Enhanced Intel Core microarchitecture due to the 128-bit shuffle unit.

7.5.1.3 Data Deswizzling

In the deswizzle operation, we want to arrange the SoA format back into AoS format so the XXXX, YYYY, and ZZZZ are rearranged and stored in memory as XYZ. Example 7-5 illustrates one deswizzle function for floating-point data.

Example 7-5. Deswizzling Single-Precision SIMD Data

```
void deswizzle_asm(Vertex_soa *in, Vertex_aos *out)
{
  __asm {
    mov     rbx, in           // load structure addresses
    mov     rdx, out
    movaps  xmm0, [rcx ]      //x3 x2 x1 x0
    movaps  xmm1, [rcx + 16]  //y3 y2 y1 y0
    movaps  xmm2, [rcx + 32]  //z3 z2 z1 z0
    movaps  xmm3, [rcx + 48]  //w3 w2 w1 w0

    movaps  xmm5, xmm0
    movaps  xmm7, xmm2
    unpcklps xmm0, xmm1      // y1 x1 y0 x0
    unpcklps xmm2, xmm3      // w1 z1 w0 z0
    movdqa  xmm4, xmm0
    movlhps xmm0, xmm2      // w0 z0 y0 x0
    movlhps xmm4, xmm2      // w1 z1 y1 x1
    unpckhps xmm5, xmm1      // y3 x3 y2 x2
    unpckhps xmm7, xmm3      // w3 z3 w2 z2
    movdqa  xmm6, xmm5
    movlhps xmm5, xmm7      // w2 z2 y2 x2
    movlhps xmm6, xmm7      // w3 z3 y3 x3
    movaps  [rdx+0*16], xmm0  //w0 z0 y0 x0
    movaps  [rdx+1*16], xmm4  //w1 z1 y1 x1
    movaps  [rdx+2*16], xmm5  //w2 z2 y2 x2
    movaps  [rdx+3*16], xmm6  //w3 z3 y3 x3
  }
}
```

Example 7-6 shows a similar deswizzle function using SIMD integer instructions. Both techniques demonstrate loading 16 bytes and performing horizontal data movement in registers. This approach is likely more efficient than alternative techniques of storing 8-byte halves of XMM registers using MOVLPS and MOVHPS.

Example 7-6. Deswizzling Data Using SIMD Integer Instructions

```

void deswizzle_rgb(Vertex_soa *in, Vertex_aos *out)
{
//---deswizzle rgb---
// assume: xmm1=rxxx, xmm2=yyyy, xmm3=bbbb, xmm4=aaaa
__asm {
    mov     rcx, in                // load structure addresses
    mov     rdx, out
    movdqa xmm0, [rcx]            // load r4 r3 r2 r1 => xmm1
    movdqa xmm1, [rcx+16]        // load g4 g3 g2 g1 => xmm2
    movdqa xmm2, [rcx+32]        // load b4 b3 b2 b1 => xmm3
    movdqa xmm3, [rcx+48]        // load a4 a3 a2 a1 => xmm4
// Start deswizzling here
    movdqa xmm5, xmm0
    movdqa xmm7, xmm2
    punpckldq xmm0, xmm1        // g2 r2 g1 r1
    punpckldq xmm2, xmm3        // a2 b2 a1 b1
    movdqa xmm4, xmm0
    punpcklqdq xmm0, xmm2        // a1 b1 g1 r1 => v1
    punpckhqdq xmm4, xmm2        // a2 b2 g2 r2 => v2
    punpckhdq xmm5, xmm1        // g4 r4 g3 r3
    punpckhdq xmm7, xmm3        // a4 b4 a3 b3
    movdqa xmm6, xmm5
    punpcklqdq xmm5, xmm7        // a3 b3 g3 r3 => v3
    punpckhqdq xmm6, xmm7        // a4 b4 g4 r4 => v4
    movdqa [rdx], xmm0          // v1
    movdqa [rdx+16], xmm4        // v2
    movdqa [rdx+32], xmm5        // v3
    movdqa [rdx+48], xmm6        // v4
// DESWIZZLING ENDS HERE
}
}

```

7.5.1.4 Horizontal ADD Using SSE

Although vertical computations generally use SIMD performance better than horizontal computations, code must use a horizontal operation in some cases.

MOVLHPS/MOVLPS and shuffle can be used to sum data horizontally. For example, starting with four 128-bit registers, to sum up each register horizontally while having the final results in one register, use the MOVLHPS/MOVLPS to align the upper and lower parts of each register. This allows you to use a vertical add. With the resulting partial horizontal summation, full summation follows easily.

Figure 7-4 presents a horizontal add using MOVLHPS/MOVLPS. Example 7-7 and Example 7-8 provide the code for this operation.

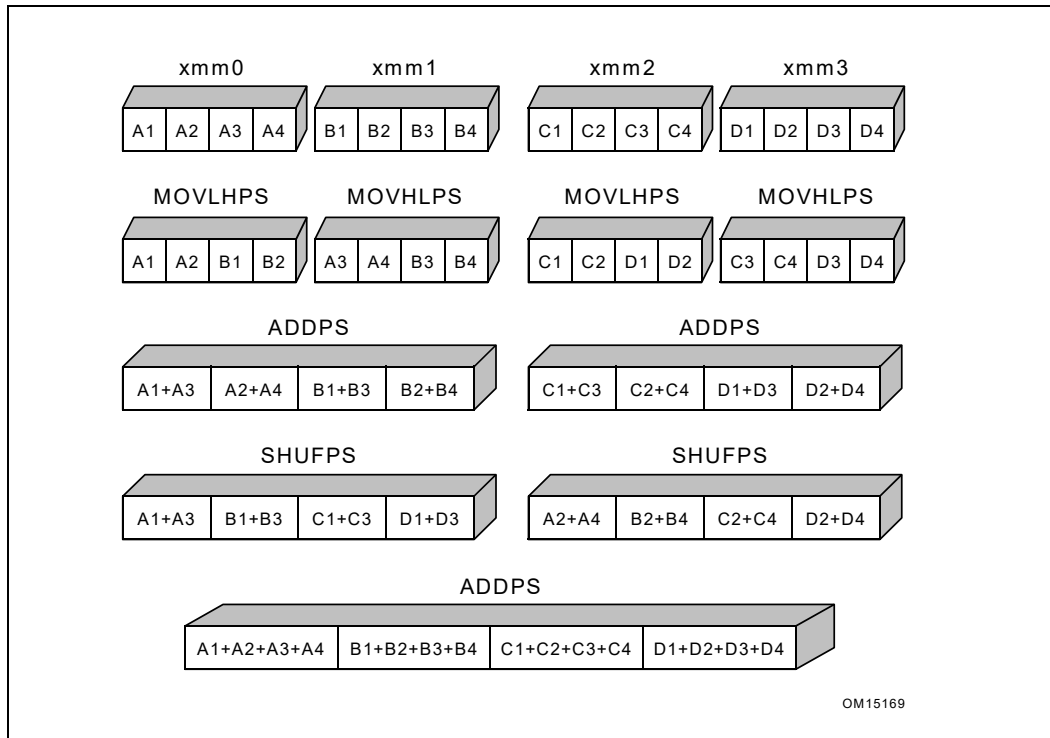

Figure 7-4. Horizontal Add Using MOVHLPS/MOVLHPS

Example 7-7. Horizontal Add Using MOVHLPS/MOVLHPS

```

void horiz_add(Vertex_soa *in, float *out) {
    __asm {
        mov     rcx, in           // load structure addresses
        mov     rdx, out
        movaps xmm0, [rcx]       // load A1 A2 A3 A4 => xmm0
        movaps xmm1, [rcx+16]    // load B1 B2 B3 B4 => xmm1
        movaps xmm2, [rcx+32]    // load C1 C2 C3 C4 => xmm2
        movaps xmm3, [rcx+48]    // load D1 D2 D3 D4 => xmm3

        // START HORIZONTAL ADD
        movaps  xmm5, xmm0        // xmm5= A1,A2,A3,A4
        movhlps xmm5, xmm1        // xmm5= A1,A2,B1,B2
        movhlps xmm1, xmm0        // xmm1= A3,A4,B3,B4
        addps   xmm5, xmm1        // xmm5= A1+A3,A2+A4,B1+B3,B2+B4

        movaps  xmm4, xmm2        // xmm4= C1,C2,C3,C4
        movhlps xmm2, xmm3        // xmm2= C1,C2,D1,D2
        movhlps xmm3, xmm4        // xmm3= C3,C4,D3,D4
        addps   xmm3, xmm2        // xmm3= C1+C3,C2+C4,D1+D3,D2+D4
        movaps  xmm6, xmm3        // xmm6= C1+C3,C2+C4,D1+D3,D2+D4
        shufps  xmm3, xmm5, 0xDD  //xmm6=A1+A3,B1+B3,C1+C3,D1+D3
        shufps  xmm5, xmm6, 0x88  // xmm5= A2+A4,B2+B4,C2+C4,D2+D4
        addps   xmm6, xmm5        // xmm6= D,C,B,A
    }
}

```

Example 7-7. Horizontal Add Using MOVHLPS/MOVLHPS (Contd.)

```

// END HORIZONTAL ADD
movaps [rdx], xmm6
}
}

```

Example 7-8. Horizontal Add Using Intrinsics with MOVHLPS/MOVLHPS

```

void horiz_add_intrin(Vertex_soa *in, float *out)
{
    __m128 v, v2, v3, v4;
    __m128 tmm0, tmm1, tmm2, tmm3, tmm4, tmm5, tmm6;

    tmm0 = _mm_load_ps(in->x);           // Temporary variables
                                         // tmm0 = A1 A2 A3 A4
    tmm1 = _mm_load_ps(in->y);           // tmm1 = B1 B2 B3 B4
    tmm2 = _mm_load_ps(in->z);           // tmm2 = C1 C2 C3 C4
    tmm3 = _mm_load_ps(in->w);           // tmm3 = D1 D2 D3 D4
    tmm5 = tmm0;                         // tmm0 = A1 A2 A3 A4
    tmm5 = _mm_movelh_ps(tmm5, tmm1);    // tmm5 = A1 A2 B1 B2
    tmm1 = _mm_movehl_ps(tmm1, tmm0);    // tmm1 = A3 A4 B3 B4
    tmm5 = _mm_add_ps(tmm5, tmm1);       // tmm5 = A1+A3 A2+A4 B1+B3 B2+B4
    tmm4 = tmm2;

    tmm2 = _mm_movelh_ps(tmm2, tmm3);    // tmm2 = C1 C2 D1 D2
    tmm3 = _mm_movehl_ps(tmm3, tmm4);    // tmm3 = C3 C4 D3 D4
    tmm3 = _mm_add_ps(tmm3, tmm2);       // tmm3 = C1+C3 C2+C4 D1+D3 D2+D4
    tmm6 = tmm3;                         // tmm6 = C1+C3 C2+C4 D1+D3 D2+D4
    tmm6 = _mm_shuffle_ps(tmm3, tmm5, 0xDD); // tmm6 = A1+A3 B1+B3 C1+C3 D1+D3
    tmm5 = _mm_shuffle_ps(tmm5, tmm6, 0x88); // tmm5 = A2+A4 B2+B4 C2+C4 D2+D4
    tmm6 = _mm_add_ps(tmm6, tmm5);       // tmm6 = A1+A2+A3+A4 B1+B2+B3+B4
                                         // C1+C2+C3+C4 D1+D2+D3+D4

    _mm_store_ps(out, tmm6);
}

```

7.5.2 Use of CVTTPS2PI/CVTSS2SI Instructions

The CVTTPS2PI and CVTSS2SI instructions implicitly encode the truncate/chop rounding mode in the instruction. They take precedence over the rounding mode specified in the MXCSR register. This behavior can eliminate the need to change the rounding mode from round-nearest, to truncate/chop, then return to round-nearest to resume computation.

Avoid frequent changes to the MXCSR register since a penalty associated with writing this register. Typically, when using CVTTPS2P/CVTSS2SI, rounding control in MXCSR can always be set to round-nearest.

7.5.3 Flush-to-Zero and Denormals-are-Zero Modes

The flush-to-zero (FTZ) and denormals-are-zero (DAZ) modes are incompatible with IEEE Standard 754. They are provided to improve performance for applications where underflow is common and generating a denormalized result is unnecessary.

See Section 3.9.2, "Floating-point Modes and Exceptions."

7.6 SIMD OPTIMIZATIONS AND MICROARCHITECTURES

Pentium M, Intel Core Solo, and Intel Core Duo processors have a different microarchitecture than the Intel NetBurst microarchitecture. Intel Core microarchitecture offers significantly more efficient SIMD floating-point capability than previous microarchitectures. In addition, instruction latency and throughput of SSE3 instructions are improved considerably in Intel Core microarchitectures over previous microarchitectures.

7.6.1 SIMD Floating-point Programming Using SSE3

SSE3 enhances SSE and SSE2 with nine instructions targeted for SIMD floating-point programming. In contrast to many SSE/SSE2 instructions offering homogeneous arithmetic operations on parallel data elements and favoring the vertical computation model, SSE3 offers instructions that perform asymmetric arithmetic and arithmetic operations on horizontal data elements.

ADDSUBPS and ADDSUBPD are two instructions with asymmetric arithmetic processing capability (see Figure 7-5). HADDPS, HADDPD, HSUBPS, and HSUBPD offer horizontal arithmetic processing capability (see Figure 7-6). In addition: MOVSLDUP, MOVSHDUP, and MOVDUP load data from memory (or XMM register) and replicate data elements simultaneously.

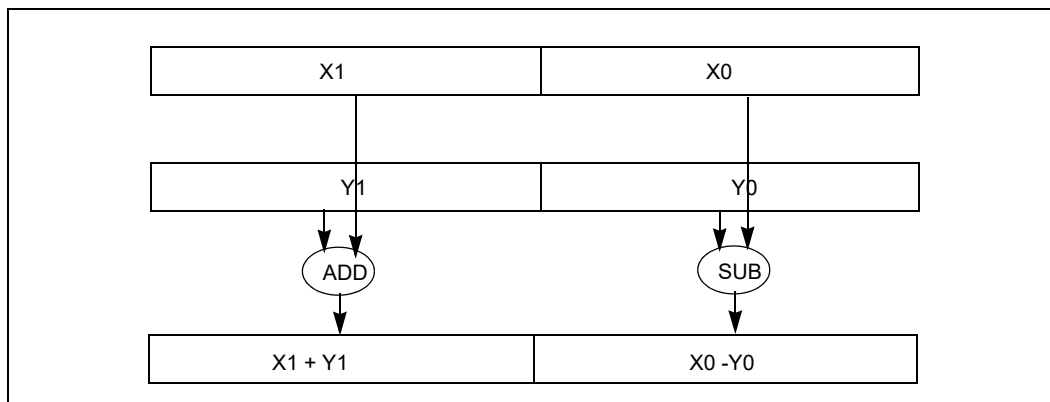

Figure 7-5. Asymmetric Arithmetic Operation of the SSE3 Instruction

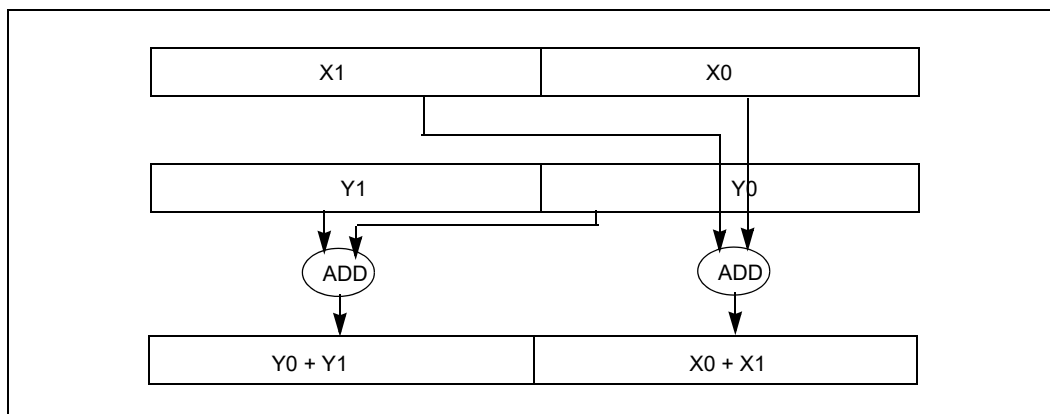

Figure 7-6. Horizontal Arithmetic Operation of the SSE3 Instruction HADDPD

7.6.1.1 SSE3 and Complex Arithmetics

The flexibility of SSE3 in dealing with AOS-type data structures can be demonstrated by the example of multiplication and division of complex numbers. For example, a complex number can be stored in a structure consisting of its real and imaginary parts. This naturally leads to the use of an array of structure. Example 7-9 demonstrates using SSE3 instructions to multiply single-precision complex numbers. Example 7-10 shows using SSE3 instructions to divide complex numbers.

Example 7-9. Multiplication of Two Pairs of Single-Precision Complex Number

```
// Multiplication of (ak + i bk ) * (ck + i dk )
// a + i b can be stored as a data structure
movsldup   xmm0, Src1; load real parts into the destination,
           ; a1, a1, a0, a0

movaps     xmm1, src2; load the 2nd pair of complex values,
           ; i.e. d1, c1, d0, c0
mulps     xmm0, xmm1; temporary results, a1d1, a1c1, a0d0,
           ; a0c0

shufps    xmm1, xmm1, b1; reorder the real and imaginary
           ; parts, c1, d1, c0, d0
movshdup  xmm2, Src1; load the imaginary parts into the
           ; destination, b1, b1, b0, b0

mulps     xmm2, xmm1; temporary results, b1c1, b1d1, b0c0,
           ; b0d0
addsubps  xmm0, xmm2; b1c1+a1d1, a1c1 -b1d1, b0c0+a0d0,
           ; a0c0-b0d0
```

Example 7-10. Division of Two Pairs of Single-Precision Complex Numbers

```
// Division of (ak + i bk ) / (ck + i dk )
movshdup  xmm0, Src1; load imaginary parts into the
           ; destination, b1, b1, b0, b0
movaps     xmm1, src2; load the 2nd pair of complex values,
           ; i.e. d1, c1, d0, c0
mulps     xmm0, xmm1; temporary results, b1d1, b1c1, b0d0,
           ; b0c0

shufps    xmm1, xmm1, b1; reorder the real and imaginary
           ; parts, c1, d1, c0, d0
movsldup  xmm2, Src1; load the real parts into the
           ; destination, a1, a1, a0, a0

mulps     xmm2, xmm1; temp results, a1c1, a1d1, a0c0, a0d0
addsubps  xmm0, xmm2; a1c1+b1d1, b1c1-a1d1, a0c0+b0d0,
           ; b0c0-a0d0

mulps     xmm1, xmm1; c1c1, d1d1, c0c0, d0d0
movps     xmm2, xmm1; c1c1, d1d1, c0c0, d0d0
shufps    xmm2, xmm2, b1; d1d1, c1c1, d0d0, c0c0
addps     xmm2, xmm1; c1c1+d1d1, c1c1+d1d1, c0c0+d0d0,
           ; c0c0+d0d0
```

Example 7-10. Division of Two Pairs of Single-Precision Complex Numbers (Contd.)

```
divps   xmm0, xmm2
shufps  xmm0, xmm0, b1 ; (b1c1-a1d1)/(c1c1+d1d1),
                    ; (a1c1+b1d1)/(c1c1+d1d1),
                    ; (b0c0-a0d0)/(c0c0+d0d0),
                    ; (a0c0+b0d0)/(c0c0+d0d0)
```

In both examples, the complex numbers are stored in arrays of structures. MOVSLDUP, MOVSHDUP, and the asymmetric ADDSUBPS allow performing complex arithmetic on two pairs of single-precision complex numbers simultaneously, without unnecessary swizzling between data elements.

Due to microarchitectural differences, software should implement the multiplication of complex double-precision numbers using SSE3 instructions on processors based on Intel Core microarchitecture. In Intel Core Duo and Intel Core Solo processors, software should use scalar SSE2 instructions to implement double-precision complex multiplication. This is because the data path between SIMD execution units is 128 bits in the Intel Core microarchitecture and 64 in previous microarchitectures. Processors based on the Enhanced Intel Core microarchitecture generally execute SSE3 instruction more efficiently than previous microarchitectures. They also have a 128-bit shuffle unit that will benefit complex arithmetic operations further than the Intel Core microarchitecture.

Example 7-11 shows two equivalent implementations of double-precision complex multiplication of two pairs of complex numbers using vector SSE2 versus SSE3 instructions. Example 7-12 shows the equivalent scalar SSE2 implementation.

Example 7-11. Double-Precision Complex Multiplication of Two Pairs

SSE2 Vector Implementation		SSE3 Vector Implementation	
movapd	xmm0, [rax] ;y x	movapd	xmm0, [rax] ;y x
movapd	xmm1, [rax+16] ;w z	movapd	xmm1, [rax+16] ;z z
unpcklpd	xmm1, xmm1 ;z z	movapd	xmm2, xmm1
movapd	xmm2, [rax+16] ;w z	unpcklpd	xmm1, xmm1
unpckhpd	xmm2, xmm2 ;w w	unpckhpd	xmm2, xmm2
mulpd	xmm1, xmm0 ;z*y z*x	mulpd	xmm1, xmm0 ;z*y z*x
mulpd	xmm2, xmm0 ;w*y w*x	mulpd	xmm2, xmm0 ;w*y w*x
xorpd	xmm2, xmm7 ;-w*y +w*x	shufpd	xmm2, xmm2, 1 ;w*x w*y
shufpd	xmm2, xmm2, 1 ;w*x -w*y	addsubpd	xmm1, xmm2 ;w*x+z*y z*x-w*y
addpd	xmm2, xmm1 ;z*y+w*x z*x-w*y	movapd	[rcx], xmm1
movapd	[rcx], xmm2		

Example 7-12. Double-Precision Complex Multiplication Using Scalar SSE2

```
movsd  xmm0, [rax] ;x
movsd  xmm5, [rax+8] ;y
movsd  xmm1, [rax+16] ;z
movsd  xmm2, [rax+24] ;w

movsd  xmm3, xmm1 ;z
movsd  xmm4, xmm2 ;w
mulsd  xmm1, xmm0 ;z*x
mulsd  xmm2, xmm0 ;w*x
mulsd  xmm3, xmm5 ;z*y
```

Example 7-12. Double-Precision Complex Multiplication Using Scalar SSE2 (Contd.)

```

mulsd  xmm4, xmm5  ;w*y
subsd  xmm1, xmm4  ;z*x - w*y
addsd  xmm3, xmm2  ;z*y + w*x
movsd  [rcx], xmm1
movsd  [rcx+8], xmm3

```

7.6.1.2 Packed Floating-Point Performance in Intel Core Duo Processor

Most of the packed SIMD floating-point code will speed up on Intel Core Solo processors relative to Pentium M processors. This is due to an improvement in decoding packed SIMD instructions.

The improved packed floating-point performance on the Intel Core Solo processor over the Pentium M processor depends on several factors. Generally, decoder-bound code with a mixture of integer and packed floating-point instructions can expect significant gain. Code that is limited by execution latency and has a “cycles per instructions” ratio greater than one will not benefit from decoder improvement.

When targeting complex arithmetics on Intel Core Solo and Intel Core Duo processors, single-precision SSE3 instructions can deliver higher performance than alternatives. On the other hand, tasks requiring double-precision complex arithmetic may perform better using scalar SSE2 instructions on Intel Core Solo and Intel Core Duo processors. This is because scalar SSE2 instructions can be dispatched through two ports and executed using two separate floating-point units.

Packed horizontal SSE3 instructions (HADDPS and HSUBPS) can simplify the code sequence for some tasks. However, these instructions consist of more than five micro-ops on Intel Core Solo and Intel Core Duo processors. Care must be taken to ensure the latency and decoding penalty of the horizontal instruction does not offset any algorithmic benefits.

7.6.2 Dot Product and Horizontal SIMD Instructions

Sometimes the AOS-type of data organization is more natural in many algebraic formulae. One typical example is the *dot product* operation. The dot product operation can be implemented using SSE/SSE2 instruction sets. SSE3 added a few horizontal add/subtract instructions for applications that rely on the horizontal computation model. SSE4.1 provides additional enhancement with instructions capable of directly evaluating dot product operations of vectors of 2, 3 or 4 components.

Example 7-13. Dot Product of Vector Length 4 Using SSE/SSE2**Using SSE/SSE2 to compute one dot product**

```

movaps  xmm0, [rax]    // a4, a3, a2, a1
mulps   xmm0, [rax+16] // a4*b4, a3*b3, a2*b2, a1*b1
movhlps xmm1, xmm0    // X, X, a4*b4, a3*b3, upper half not needed
addps   xmm0, xmm1    // X, X, a2*b2+a4*b4, a1*b1+a3*b3,
pshufd  xmm1, xmm0, 1  // X, X, X, a2*b2+a4*b4
addss   xmm0, xmm1    // a1*b1+a3*b3+a2*b2+a4*b4
movss   [rcx], xmm0

```

Example 7-14. Dot Product of Vector Length 4 Using SSE3

Using SSE3 to compute one dot product		
movaps	xmm0, [rax]	
mulps	xmm0, [rax+16]	// a4*b4, a3*b3, a2*b2, a1*b1
haddps	xmm0, xmm0	// a4*b4+a3*b3, a2*b2+a1*b1, a4*b4+a3*b3, a2*b2+a1*b1
movaps	xmm1, xmm0	// a4*b4+a3*b3, a2*b2+a1*b1, a4*b4+a3*b3, a2*b2+a1*b1
psrlq	xmm0, 32	// 0, a4*b4+a3*b3, 0, a4*b4+a3*b3
addss	xmm0, xmm1	// -, -, -, a1*b1+a3*b3+a2*b2+a4*b4
movss	[rax], xmm0	

Example 7-15. Dot Product of Vector Length 4 Using SSE4.1

Using SSE4.1 to compute one dot product		
movaps	xmm0, [rax]	
dpps	xmm0, [rax+16], 0xf1	// 0, 0, 0, a1*b1+a3*b3+a2*b2+a4*b4
movss	[rax], xmm0	

Example 7-13, Example 7-14, and Example 7-15 compare the basic code sequence to compute one dot-product result for a pair of vectors.

The selection of an optimal sequence in conjunction with an application's memory access patterns may favor different approaches. For example, if each dot product result is immediately consumed by additional computational sequences, it may be more optimal to compare the relative speed of these different approaches. If dot products can be computed for an array of vectors and kept in the cache for subsequent computations, then more optimal choice may depend on the relative throughput of the sequence of instructions.

In Intel Core microarchitecture, Example 7-14 has higher throughput than Example 7-13. Due to the relatively longer latency of HADDPS, the speed of Example 7-14 is slightly slower than Example 7-13.

In Enhanced Intel Core microarchitecture, Example 7-15 is faster in both speed and throughput than Example 7-13 and Example 7-14. Although the latency of DPPS is also relatively long, it is compensated by the reduction of number of instructions in Example 7-15 to do the same amount of work.

Unrolling can further improve the throughput of each of three dot product implementations.

Example 7-16 shows two unrolled versions using the basic SSE2 and SSE3 sequences. The SSE4.1 version can also be unrolled and using INSERTPS to pack 4 dot-product results.

Example 7-16. Unrolled Implementation of Four Dot Products

SSE2 Implementation			SSE3 Implementation	
movaps	xmm0, [rax]		movaps	xmm0, [rax]
mulps	xmm0, [rax+16]	;w0*w1 z0*z1 y0*y1 x0*x1	mulps	xmm0, [rax+16]
movaps	xmm2, [rax+32]		movaps	xmm1, [rax+32]
mulps	xmm2, [rax+16+32]	;w2*w3 z2*z3 y2*y3 x2*x3	mulps	xmm1, [rax+16+32]
movaps	xmm3, [rax+64]		movaps	xmm2, [rax+64]
mulps	xmm3, [rax+16+64]	;w4*w5 z4*z5 y4*y5 x4*x5	mulps	xmm2, [rax+16+64]
movaps	xmm4, [rax+96]		movaps	xmm3, [rax+96]
mulps	xmm4, [rax+16+96]	;w6*w7 z6*z7 y6*y7 x6*x7	mulps	xmm3, [rax+16+96]
			haddps	xmm0, xmm1
			haddps	xmm2, xmm3
			haddps	xmm0, xmm2
			movaps	[rcx], xmm0

Example 7-16. Unrolled Implementation of Four Dot Products (Contd.)

SSE2 Implementation	SSE3 Implementation
<pre> movaps xmm1, xmm0 unpcklps xmm0, xmm2 ; y2*y3 y0*y1 x2*x3 x0*x1 unpckhps xmm1, xmm2 ; w2*w3 w0*w1 z2*z3 z0*z1 movaps xmm5, xmm3 unpcklps xmm3, xmm4 ; y6*y7 y4*y5 x6*x7 x4*x5 unpckhps xmm5, xmm4 ; w6*w7 w4*w5 z6*z7 z4*z5 addps xmm0, xmm1 addps xmm5, xmm3 movaps xmm1, xmm5 movhlps xmm1, xmm0 movlhps xmm0, xmm5 addps xmm0, xmm1 movaps [rcx], xmm0 </pre>	

7.6.3 Vector Normalization

Normalizing vectors is a common operation in many floating-point applications. Example 7-17 shows an example in C of normalizing an array of (x, y, z) vectors.

Example 7-17. Normalization of an Array of Vectors

```

for (i=0;i<CNT;i++)
{ float size = nodes[i].vec.dot();
  if (size != 0.0)
  { size = 1.0f/sqrtf(size); }
  else
  { size = 0.0; }
  nodes[i].vec.x *= size;
  nodes[i].vec.y *= size;
  nodes[i].vec.z *= size;
}

```

Example 7-18 shows an assembly sequence that normalizes the x, y, z components of a vector.

Example 7-18. Normalize (x, y, z) Components of an Array of Vectors Using SSE2

```

Vec3 *p = &nodes[i].vec;
__asm
{
  mov    rax, p
  xorps  xmm2, xmm2
  movups xmm1, [rax]           // loads the (x, y, z) of input vector plus x of next vector
  movaps xmm7, xmm1           // save a copy of data from memory (to restore the unnormalized value)
  movaps xmm5, _mask          // mask to select (x, y, z) values from an xmm register to normalize
  andps  xmm1, xmm5           // mask 1st 3 elements
  movaps xmm6, xmm1           // save a copy of (x, y, z) to compute normalized vector later
  mulps  xmm1, xmm1           // 0, z*z, y*y, x*x
  pshufd xmm3, xmm1, 0x1b     // x*x, y*y, z*z, 0
  addps  xmm1, xmm3           // x*x, z*z+y*y, z*z+y*y, x*x
  pshufd xmm3, xmm1, 0x41     // z*z+y*y, x*x, x*x, z*z+y*y
  addps  xmm1, xmm3           // x*x+y*y+z*z, x*x+y*y+z*z, x*x+y*y+z*z, x*x+y*y+z*z
  comisd xmm1, xmm2           // compare size to 0
  jz     zero
  movaps xmm3, xmm4           // preloaded unitary vector (1.0, 1.0, 1.0, 1.0)
  sqrtps xmm1, xmm1
  divps  xmm3, xmm1
  jmp    store
zero:
  movaps xmm3, xmm2
store:
  mulps  xmm3, xmm6           //normalize the vector in the lower 3 elements
  andnps xmm5, xmm7           // mask off the lower 3 elements to keep the un-normalized value
  orps   xmm3, xmm5           // order the un-normalized component after the normalized vector
  movaps [rax], xmm3         // writes normalized x, y, z; followed by unmodified value
}

```

Example 7-19 shows an assembly sequence using SSE4.1 to normalize the x, y, z components of a vector.

Example 7-19. Normalize (x, y, z) Components of an Array of Vectors Using SSE4.1

```

Vec3 *p = &nodes[i].vec;
__asm
{
    mov    rax, p
    xorps  xmm2, xmm2
    movups xmm1, [rax]           // loads the (x, y, z) of input vector plus x of next vector
    movaps xmm7, xmm1           // save a copy of data from memory
    dpps   xmm1, xmm1, 0x7f     // x*x+y*y+z*z, x*x+y*y+z*z, x*x+y*y+z*z, x*x+y*y+z*z
    comisd xmm1, xmm2           // compare size to 0
    jz     zero
    movaps xmm3, xmm4           // preloaded unitary vector (1.0, 1.0, 1.0, 1.0)
    sqrtps xmm1, xmm1
    divps  xmm3, xmm1
    jmp    store
zero:
    movaps xmm3, xmm2
store:
    mulps  xmm3, xmm6           //normalize the vector in the lower 3 elements
    blendps xmm3, xmm7, 0x8     // copy the un-normalized component next to the normalized vector
    movaps [rax], xmm3

```

In Example 7-18 and Example 7-19, the throughput of these instruction sequences are basically limited by the long-latency instructions of DIVPS and SQRTPS. In Example 7-19, the use of DPPS replaces eight SSE2 instructions to evaluate and broadcast the dot-product result to four elements of an XMM register. This could result in improvement of the relative speed of Example 7-19 over Example 7-18.

7.6.4 Using Horizontal SIMD Instruction Sets and Data Layout

SSE and SSE2 provide packed add/subtract, multiply/divide instructions that are ideal for situations that can take advantage of vertical computation model, such as SOA data layout. SSE3 and SSE4.1 added horizontal SIMD instructions including horizontal add/subtract, dot-product operations. These more recent SIMD extensions provide tools to solve problems involving data layouts or operations that do not conform to the vertical SIMD computation model.

In this section, we consider a vector-matrix multiplication problem and discuss the relevant factors for choosing various horizontal SIMD instructions.

Example 7-20 shows the vector-matrix data layout in AOS, where the input and out vectors are stored as an array of structure.

Example 7-20. Data Organization in Memory for AOS Vector-Matrix Multiplication

Matrix M4x4 (pMat):	M00 M01 M02 M03
	M10 M11 M12 M13
	M20 M21 M22 M23
	M30 M31 M32 M33
4 input vertices V4x1 (pVert):	V0x V0y V0z V0w
	V1x V1y V1z V1w
	V2x V2y V2z V2w
	V3x V3y V3z V3w
Output vertices O4x1 (pOutVert):	O0x O0y O0z O0w
	O1x O1y O1z O1w
	O2x O2y O2z O2w
	O3x O3y O3z O3w

Example 7-21 shows an example using HADDPS and MULPS to perform vector-matrix multiplication with data layout in AOS. After three HADDPS completing the summations of each output vector component, the output components are arranged in AOS.

Example 7-21. AOS Vector-Matrix Multiplication with HADDPS

```

mov    rax, pMat
mov    rbx, pVert
mov    rcx, pOutVert
xor    rdx, rdx
movaps xmm5,[rax+16]    // load row M1?
movaps xmm6,[rax+2*16] // load row M2?
movaps xmm7,[rax+3*16] // load row M3?
loop:
movaps xmm4, [rbx + rdx] // load input vector
movaps xmm0, xmm4
mulps  xmm0, [rax]      // m03*vw, m02*vz, m01*vy, m00*vx,
movaps xmm1, xmm4
mulps  xmm1, xmm5      // m13*vw, m12*vz, m11*vy, m10*vx,

movaps xmm2, xmm4
mulps  xmm2, xmm6      // m23*vw, m22*vz, m21*vy, m20*vx
movaps xmm3, xmm4
mulps  xmm3, xmm7      // m33*vw, m32*vz, m31*vy, m30*vx,
haddps xmm0, xmm1
haddps xmm2, xmm3
haddps xmm0, xmm2
movaps [rcx + rdx], xmm0 // store a vector of length 4
add    rdx, 16
cmp    rdx, top
jb    loop

```

Example 7-22 shows an example using DPPS to perform vector-matrix multiplication in AOS.

Example 7-22. AOS Vector-Matrix Multiplication with DPPS

```

mov    rax, pMat
mov    rbx, pVert
mov    rcx, pOutVert
xor    rdx, rdx
movaps xmm5,[rax+16]      // load row M1?
movaps xmm6,[rax+2*16]   // load row M2?
movaps xmm7,[rax+3*16]   // load row M3?
lloop:
movaps xmm4, [rbx + rdx]  // load input vector
movaps xmm0, xmm4
dpps  xmm0, [rax], 0xf1   // calculate dot product of length 4, store to lowest dword
movaps xmm1, xmm4
dpps  xmm1, xmm5, 0xf1
movaps xmm2, xmm4
dpps  xmm2, xmm6, 0xf1
movaps xmm3, xmm4
dpps  xmm3, xmm7, 0xf1
movss [rcx + rdx + 0*4], xmm0 // store one element of vector length 4
movss [rcx + rdx + 1*4], xmm1
movss [rcx + rdx + 2*4], xmm2
movss [rcx + rdx + 3*4], xmm3
add   rdx, 16
cmp   rdx, top
jb    lloop

```

Example 7-21 and Example 7-22 both work with AOS data layout using different horizontal processing techniques provided by SSE3 and SSE4.1. The effectiveness of either techniques will vary, depending on the degree of exposures of long-latency instruction in the inner loop, the overhead/efficiency of data movement, and the latency of HADDPS vs. DPPS.

On processors that support both HADDPS and DPPS, the choice between either technique may depend on application-specific considerations. If the output vectors are written back to memory directly in a batch situation, Example 7-21 may be preferable over Example 7-22, because the latency of DPPS is long and storing each output vector component individually is less than ideal for storing an array of vectors.

There may be partially-vectorizable situations that the individual output vector component is consumed immediately by other non-vectorizable computations. Then, using DPPS producing individual component may be more suitable than dispersing the packed output vector produced by three HADDPS as in Example 7-21.

7.6.4.1 SOA and Vector Matrix Multiplication

If the native data layout of a problem conforms to SOA, then vector-matrix multiply can be coded using MULPS, ADDPS without using the longer-latency horizontal arithmetic instructions, or packing scalar components into packed format (Example 7-22). To achieve higher throughput with SOA data layout, there are either prerequisite data preparation or swizzling/deswizzling on-the-fly that must be comprehended. For example, an SOA data layout for vector-matrix multiplication is shown in Example 7-23.

Each matrix element is replicated four times to minimize data movement overhead for producing packed results.

Example 7-23. Data Organization in Memory for SOA Vector-Matrix Multiplication

Matrix M16x4 (pMat):	
	M00 M00 M00 M00 M01 M01 M01 M01 M02 M02 M02 M02 M03 M03 M03 M03
	M10 M10 M10 M10 M11 M11 M11 M11 M12 M12 M12 M12 M13 M13 M13 M13
	M20 M20 M20 M20 M21 M21 M21 M21 M22 M22 M22 M22 M23 M23 M23 M23
	M30 M30 M30 M30 M31 M31 M31 M31 M32 M32 M32 M32 M33 M33 M33 M33
4 input vertices V4x1 (pVert):	V0x V1x V2x V3x
	V0y V1y V2y V3y
	V0z V1z V2z V3z
	V0w V1w V2w V3w
Output vertices O4x1 (pOutVert):	O0x O1x O2x O3x
	O0y O1y O2y O3y
	O0z O1z O2z O3z
	O0w O1w O2w O3w

The corresponding vector-matrix multiply example in SOA (unrolled for four iteration of vectors) is shown in Example 7-24.

Example 7-24. Vector-Matrix Multiplication with Native SOA Data Layout

```

mov    rbx, pVert
mov    rcx, pOutVert
xor    rdx, rdx
movaps xmm5,[rax + 16]    // load row M1?
movaps xmm6,[rax + 2*16]  // load row M2?
movaps xmm7,[rax + 3*16]  // load row M3?
loop_vert:
mov    rax, pMat
xor    edi, edi
movaps xmm0, [rbx]        // load V3x, V2x, V1x, V0x
movaps xmm1, [rbx]        // load V3y, V2y, V1y, V0y
movaps xmm2, [rbx]        // load V3z, V2z, V1z, V0z
movaps xmm3, [rbx]        // load V3w, V2w, V1w, V0w
loop_mat:
movaps xmm4, [rax]        // m00, m00, m00, m00,
mulps  xmm4, xmm0         // m00*V3x, m00*V2x, m00*V1x, m00*V0x,
movaps xmm4, [rax + 16]   // m01, m01, m01, m01,
mulps  xmm5, xmm1         // m01*V3y, m01*V2y, m01*V1y, m01*V0y,
addps  xmm4, xmm5
movaps xmm5, [rax + 32]   // m02, m02, m02, m02,
mulps  xmm5, xmm2         // m02*V3z, m02*V2z, m02*V1z, m02*V0z,
addps  xmm4, xmm5
movaps xmm5, [rax + 48]   // m03, m03, m03, m03,
mulps  xmm5, xmm3         // m03*V3w, m03*V2w, m03*V1w, m03*V0w,
addps  xmm4, xmm5
movaps [rcx + rdx], xmm4
add    rax, 64
add    rdx, 16
add    edi, 1
cmp    edi, 4
jb    loop_mat
add    rbx, 64
cmp    rdx, top
jb    loop_vert

```

CHAPTER 8

INT8 DEEP LEARNING INFERENCE

This chapter describes INT8 as a data type for Deep learning Inference on Intel technology. The document covers both AVX-512 implementations and implementations using the new Intel® DL Boost Instructions.

The chapter is divided into several parts. The first part introduces INT8, and more specifically the Intel DL Boost instructions as the core data type and instructions for use in ML workloads. The second part discusses general methodologies and guidelines for efficient inference computation. The third part discusses optimizations specific to CNNs and the final part discusses optimizations specific to LSTM/RNNs.

When relevant, examples are provided with and without the new Intel DL Boost instruction set. In many cases (quantization, memory layout) there are steps that can be taken offline and steps that must be taken in runtime; we try to clearly state when each step is taken.

8.1 INTRODUCING INT8 AS DATA TYPE FOR DEEP LEARNING INFERENCE

Traditionally, deep learning is done with Single Precision Floating Point (F32) data type (see <https://itpeernetwork.intel.com/myth-busted-general-purpose-cpus-cant-tackle-deep-neural-network-training/#gs.rGp9lgWH>). Lately, INT8 has been used successfully for deep learning inference with a significant boost to performance and little loss of accuracy. The 4x narrower data type and the 3x more Intel® AVX-512 instructions required for INT8 MAC operation (vs. a single F32 FMA instruction) provide a net 1.33x nominal gain. Our experience with ResNet-50, Inception-Resnet v2, SRGAN and NMT on the Intel® Xeon® Processor Scalable Family based on Skylake microarchitecture shows >1.5x speedup due to the INT8 smaller memory footprint. Section 8.2 describes Intel Deep Learning Boost instructions introduced in processors based on the Cascade Lake product, which further increase DL Inference performance.

We consider two use cases for DL Inference Workloads. The first usage is the Throughput Model, where elements (images, sentences) are processed regardless of how long it takes to process a single element. This usage model is usually appropriate for servers that process a bulk of images for classification or offline preparation of recommendations tailored to specific users. The second usage model is the Throughput at Latency Model where there is an upper limit for the time it is acceptable to compute a single element. This usage model is usually appropriate for online computation (language translation, real-time object detection, etc.).

8.2 INTRODUCING INTEL® DL BOOST

Intel® DL Boost instructions are a set of Intel AVX-512 instructions that are designed to speed up neural network workloads. These instructions are supported if `CPUID.07H.0H:ECX.AVX512_VNNI[bit 11] = 1`.

The following sections describe these new instructions and show a simple comparison to previous Intel AVX-512 code. Refer to the *Intel® Architecture Instruction Set Extensions Programming Reference* or the *Intel® 64 and IA-32 Architectures Software Developer's Manual* for complete instruction definitions (instructions with prefix VPDP).

8.2.1 Multiply and Add Unsigned and Signed Bytes (VPDPBUSD Instruction)

VPDPBUSD is an 8-bit integer multiply-accumulate vector operation into a vector of 32-bit integer accumulators. It accepts two source vector operands and one source/destination vector operand. The two source operands contain 8-bit integer data elements. The source/destination operand contains 32-bit data elements.

As an example, take 512-bit vector operands where each of the source operands contains 64 x 8-bit elements and the source/destination operand contains 16 x 32-bit elements.

The instruction splits the 64 elements in each source operand into 16 quadruples and multiplies vertically the four members of each quadruple, one from each source operand to create four 32-bit intermediate results. It then performs a 5-way addition of the four 32-bit intermediate results and the vertically corresponding 32-bit integer element in its 3rd vector operand (serving here as a source operand) and places the result of the 5-way addition in the same place of the 32-bit data element in the 3rd vector operand (now serving as a destination operand). VPDPBUSD replaces an Intel AVX-512 three instruction sequence that accomplishes the same functionality with higher accuracy since Intel AVX-512 saturates the 16-bit intermediate results: VPMADDUBSW + VPMADDWD + VPADDD. See Figure below.

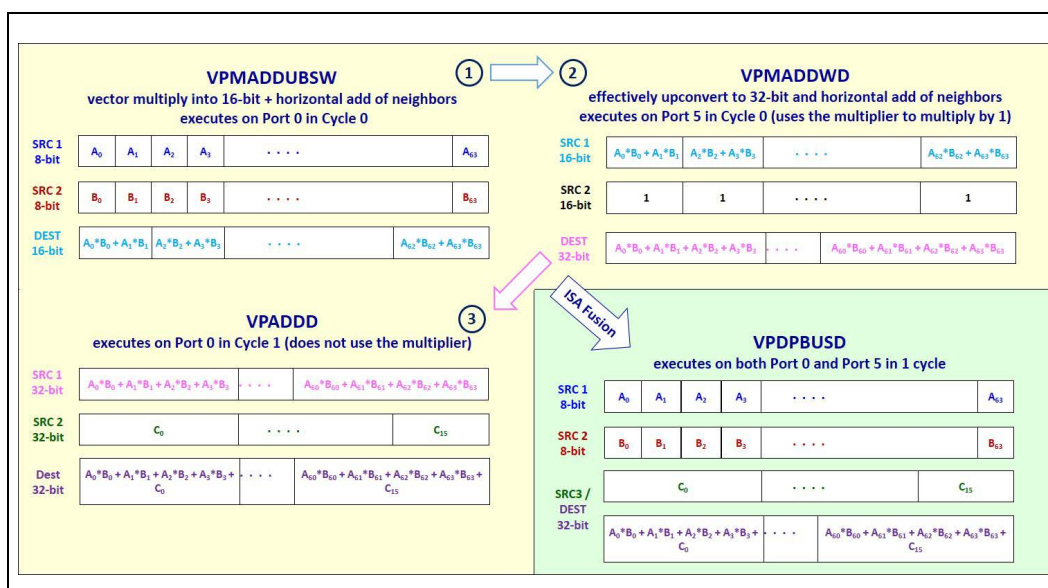

VPADDUBSW + VPMADDWD + VPADDD Fused into VPDPBUSD (3x Peak Ops on Server Architectures, 2x Peak Ops on Client Architectures)

Example 8-1 uses the VPDPBUSD instruction to perform faster matrix multiplication of two byte matrices, SIGNAL and WEIGHT. Assuming the source matrices have dimensions MxK and KxN, respectively, and are given in row-major order, the source matrices in the example have the layouts defined below.

- Matrix signal[K/64][M][64], built out of matrix SIGNAL[M][K] by the following procedure:
 FOR m = 0 ... M-1
 FOR k = 0 ... K-1
 signal[k/64][m][k%64] = SIGNAL[m][k]
- Matrix weight[K/4][N][4], built out of matrix WEIGHT[K][N] by the following procedure:
 FOR k = 0 ... K-1
 FOR n = 0 ... N-1
 weight[k/4][n][k%4] = WEIGHT[k][n]

Example 8-1. VPDPBUSD Implementation

Vector Implementation with pre-Intel® DL Boost (Intel® AVX-512)	Intel® DL Boost VPDPBUSD Implementation
<pre>// inner loop of unrolled matrix multiply vpbroadcastd zmm31, dword ptr [onew] vpbroadcastd zmm24, [signal] vmovups zmm25, [weight] vmovups zmm26, [weight + 64] vmovups zmm27, [weight + 128] vmovups zmm28, [weight + 192] vpmaddubsw zmm29, zmm24, zmm25 vpmaddwd zmm29, zmm29, zmm31 vpadd zmm0, zmm0, zmm29 vpmaddubsw zmm30, zmm24, zmm26 vpmaddwd zmm30, zmm30, zmm31 vpadd zmm6, zmm6, zmm30 vpmaddubsw zmm29, zmm24, zmm27 vpmaddwd zmm29, zmm29, zmm31 vpadd zmm12, zmm12, zmm29 vpmaddubsw zmm30, zmm24, zmm28 vpmaddwd zmm30, zmm30, zmm31 vpadd zmm18, zmm18, zmm30 vpbroadcastd zmm24, [signal + 64] vpmaddubsw zmm29, zmm24, zmm25 vpmaddwd zmm29, zmm29, zmm31 vpadd zmm1, zmm1, zmm29 vpmaddubsw zmm30, zmm24, zmm26 vpmaddwd zmm30, zmm30, zmm31 vpadd zmm7, zmm7, zmm30 vpmaddubsw zmm29, zmm24, zmm27 vpmaddwd zmm29, zmm29, zmm31 vpadd zmm13, zmm13, zmm29 vpmaddubsw zmm30, zmm24, zmm28 vpmaddwd zmm30, zmm30, zmm31 vpadd zmm19, zmm19, zmm30 vpbroadcastd zmm24, [signal + 128] vpmaddubsw zmm29, zmm24, zmm25 vpmaddwd zmm29, zmm29, zmm31 vpadd zmm2, zmm2, zmm29 vpmaddubsw zmm30, zmm24, zmm26 vpmaddwd zmm30, zmm30, zmm31 vpadd zmm8, zmm8, zmm30 vpmaddubsw zmm29, zmm24, zmm27 vpmaddwd zmm29, zmm29, zmm31 vpadd zmm14, zmm14, zmm29 vpmaddubsw zmm30, zmm24, zmm28 vpmaddwd zmm30, zmm30, zmm31 vpadd zmm20, zmm20, zmm30 vpbroadcastd zmm24, [signal + 192] vpmaddubsw zmm29, zmm24, zmm25</pre>	<pre>// inner loop of unrolled matrix multiply vpbroadcastd zmm24, [signal] vpbroadcastd zmm25, [signal + 64] vpbroadcastd zmm26, [signal + 128] vpbroadcastd zmm27, [signal + 192] vmovups zmm28, [weight] vmovups zmm29, [weight + 64] vmovups zmm30, [weight + 128] vmovups zmm31, [weight + 192] vpdpbusd zmm0, zmm24, zmm28 vpdpbusd zmm6, zmm24, zmm29 vpdpbusd zmm12, zmm24, zmm30 vpdpbusd zmm18, zmm24, zmm31 vpdpbusd zmm1, zmm25, zmm28 vpdpbusd zmm7, zmm25, zmm29 vpdpbusd zmm13, zmm25, zmm30 vpdpbusd zmm19, zmm25, zmm31 vpdpbusd zmm2, zmm26, zmm28 vpdpbusd zmm8, zmm26, zmm29 vpdpbusd zmm14, zmm26, zmm30 vpdpbusd zmm20, zmm26, zmm31 vpdpbusd zmm3, zmm27, zmm28 vpdpbusd zmm9, zmm27, zmm29 vpdpbusd zmm15, zmm27, zmm30 vpdpbusd zmm21, zmm27, zmm31</pre>

Example 8-1. VPDPBUSD Implementation (Contd.)

<pre> vpmaddwd zmm29, zmm29, zmm31 vpadd zmm3, zmm3, zmm29 vpmaddubsw zmm30, zmm24, zmm26 vpmaddwd zmm30, zmm30, zmm31 vpadd zmm9, zmm9, zmm30 vpmaddubsw zmm29, zmm24, zmm27 vpmaddwd zmm29, zmm29, zmm31 vpadd zmm15, zmm15, zmm29 vpmaddubsw zmm30, zmm24, zmm28 vpmaddwd zmm30, zmm30, zmm31 vpadd zmm21, zmm21, zmm30 </pre>	
Baseline	Speedup: 2.75x ¹

NOTES:

1. Client architectures based on processors that support Intel® DL Boost, such as processors based on Ice Lake microarchitecture will only see a 2x speedup. This is because VPADD can exploit the vector SIMD unit on port 5 so the baseline takes 2 cycles per 64 MACs (peak) vs. 1 cycle with Intel® DL Boost.

8.2.2 Multiply and Add Signed Word Integers (VPDPWSSD Instruction)

VPDPWSSD is a 16-bit integer multiply-accumulate vector operation into a vector of 32-bit integer accumulators. It accepts two source vector operands and one source/destination vector operand. The two source operands contain 16-bit integer data elements. The source/destination operand contains 32-bit data elements.

If the use of the 8-bit VPDPBUSD instruction introduces an unacceptable loss in inference accuracy, the 16-bit VPDPWSSD instruction can be used instead. Still, it is recommended to revert to FP32 operations in such scenarios until the new BFLOAT16 data type and its associated operations are supported by Intel processors.

No performance gain is expected from the VPDPWSSD instruction on client architectures such as the Ice Lake Client microarchitecture.

8.3 GENERAL OPTIMIZATIONS**8.3.1 Memory Layout**

Assume the NHWC memory layout is as described in the TensorFlow performance guide (for additional details, see the [data formats](#) section of this document). If the inputs are given in native format (either row or column major) the data is converted to an optimized layout at the beginning of the computation with scalar code; see the [Intel AI Academy](#) for additional details.

8.3.2 Quantization

Quantization is the process of reducing the size of the data type for activations and weights, typically from floats to int8/uint8, and is thoroughly discussed in various resources such as the [MKL-DNN documentation](#) and the [Intel AI Academy](#).

8.3.2.1 Quantization of Weights

Weights are quantized using the quantization factor $127/\text{max_range}$. This can be done per OFM for increased accuracy. Since weights are known up-front the process can be done offline.

8.3.2.2 Quantization of Activations

The following code snippet shows how to quantize data in scalar or vector fashion, given a quantization factor.

Example 8-2. Quantization of Activations

Quantization of Inputs with a Given Factor (Scalar)

```
void quantize_activations(const float* data, u8* quantized_data, int count, Dtype factor, int bits, int offset = 0)
{
    int quant_min = 0;
    int quant_max = (1 << bits) - 1;
    #pragma unroll (4)
    for (int i = 0; i < count; i++) {
        int int32_val = offset + (int)round(data[i] * factor);
        int32_val = std::max(std::min(int32_val, quant_max), quant_min);
        u8 quant_val = (u8)int32_val;
        quantized_data[i] = quant_val;
    }
}
```

Quantization of Inputs with a Given Factor (Vectorized)

```
void quantize_activations(const float* data, u8* quantized_data, int count, Dtype factor, int bits, int offset = 0)
{
    int quant_min = 0;
    int quant_max = (1 << bits) - 1;
    int count_aligned = ALIGN(count, INTR_VECTOR_LENGTH_32_bit);
    __m512i offset_broadcast = _mm512_set1_epi32(offset);
    __m512 factor_broadcast = _mm512_set1_ps(factor);
    __m512i quant_min_broadcast = _mm512_set1_epi32(quant_min);
    __m512i quant_max_broadcast = _mm512_set1_epi32(quant_max);

    #pragma unroll (4)
    for (int i = 0; i < count_aligned; i += INTR_VECTOR_LENGTH_32_bit) {
        __m512 data_m512 = _mm512_load_ps(&data[i]);
        data_m512 = _mm512_mul_ps(data_m512, factor_broadcast);
        __m512i data_i32 = _mm512_cvt_roundps_epi32 (data_m512, _MM_FROUND_TO_NEAR-
EST_INT|_MM_FROUND_NO_EXC);
        data_i32 = _mm512_add_epi32(data_i32, offset_broadcast);
        data_i32 = _mm512_max_epi32(data_i32, quant_min_broadcast);
        data_i32 = _mm512_min_epi32(data_i32, quant_max_broadcast);
        __m128i q = _mm512_cvtusepi32_epi8(data_i32);
        _mm_store_si128((__m128i*)&quantized_data[i], q);
    }
}
```

8.3.2.3 Quantizing Negative Activations

VPMADDUBSW and VPDPBUSD only support the combination of an unsigned value in the first parameter and a signed value in the second parameter. This means that signed weights (in the second parameter) can be easily supported, but signed activations (in the first parameter) require some manipulations. When there is a possibility of negative activations, e.g., when there is no ReLU before the current layer, we first quantize to the values of -128, 127 and then add 128 to the result to achieve non-negative activations. We compensate for this offset by subtracting $128 * (\text{sum of all the weights of the OFM filter})$ from the OFM bias; see the [Intel AI Academy](#) for the full details.

8.3.3 Multicore Considerations

8.3.3.1 Large Batch (Throughput Workload)

Computation of large batches can benefit significantly from multicore processing by dividing the work among multiple cores but, due to cache locality, it is best to fully process the same object (image, sentence, etc.) on the same physical core. Furthermore, while the activations are unique per object, the weights can usually be shared. A multithreaded model allows for easy sharing of weights between the cores. Guidelines for processing large batch of input in a multicore system are listed below.

1. Use a thread model to share the weights between the multiple cores. That said, for multi-socket machines there should be a dedicated process per socket/NUMA domain.
2. Define thread affinity and object affinity to fully process a single object in the same physical core, thus keeping the activations in core caches (unless larger than the caches size).
3. Batch objects to a whole multiple of the core count so that the work will be evenly loaded between the cores.
4. Ensure that the sibling thread (logical processor) of every physical core is idle.
5. Consider running a per core mini-batch in BFS mode where, for example, the same layer is executed for all the images assigned to the core before moving to the next layer. This improves weight reuse at the cost of polluting the core caches with multiple activations and (sometimes) improves performance. Mini-batching is quite useful when the sizes of the matrices (tensors) are otherwise very skinny, causing under-utilization of the multiply-accumulate units.

8.3.3.2 Small Batch (Throughput at Latency Workload)

Small batch processing usually has some latency requirements which are not always possible to fulfill with a single core. In such cases it is necessary to split the processing of a single object across multiple cores.

Increasing the number of cores that process a single object often has diminishing returns, so it is best to find the knee point. Sometimes it is possible to slightly increase the batch count and still hit the required latency (e.g., from one to two or three). Once the optimal thread count of a single batch instance is found, multiple instances can be run to fully utilize the system.

8.3.3.3 NUMA

The Cascade Lake Advanced Performance 2-Socket server contains two Cascade Lake Advanced Performance packages where each of the packages is made of two processor dies connected via one Intel® Ultra Path Interconnect (Intel® UPI) link, creating a total of four NUMA domains. In such a setup it is crucial to maintain a separate DL process per NUMA domain/die. This is also the case for previous 2-socket setups of the previous generation product lines with multiple NUMA domains.

8.4 CNNs

8.4.1 Convolutional Layers

8.4.1.1 Direct Convolution

In order to utilize Intel[®] DL Boost vector operations we strive to reduce the direct convolution operation into a series of matrix additions and multiplications. In the following discussion we denote the matrices replacing the inputs, weights and outputs as A, B and C respectively.

Memory Layout

In order to present the inputs in matrix form we flatten the spatial dimension to be the rows of A (henceforth called the M dimension), and the channel (IFM) dimension to be the columns of A (henceforth called the K dimension). Similarly the spatial dimension of the outputs becomes the rows of C, and the channel (OFM) dimension becomes the columns of C (henceforth called the N dimension). In Figure 8-1 there are six channels of size 5x5 in the inputs which are transformed by the convolutional layer to four channels of size 3x3.

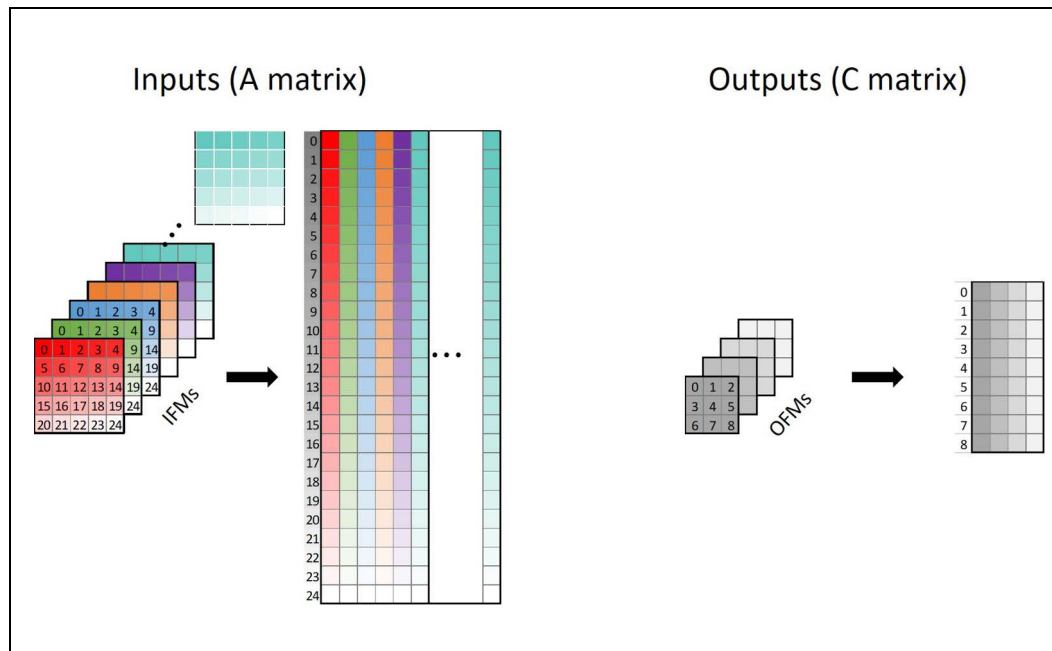

Figure 8-1. Matrix Layout, Inputs and Outputs

Standard 2D convolution uses #OFMs different 3D kernels of size $KH \times KW \times \#IFMs$, for each target OFM, where KH , KW , $\#IFMs$ and $\#OFMs$ are the height and width of the convolutional kernel, number of input channels and number of output channels respectively.

The weights are transformed into $KH \times KW$ matrices of size $\#IFMs \times \#OFMs$ (see Figure 8-2).

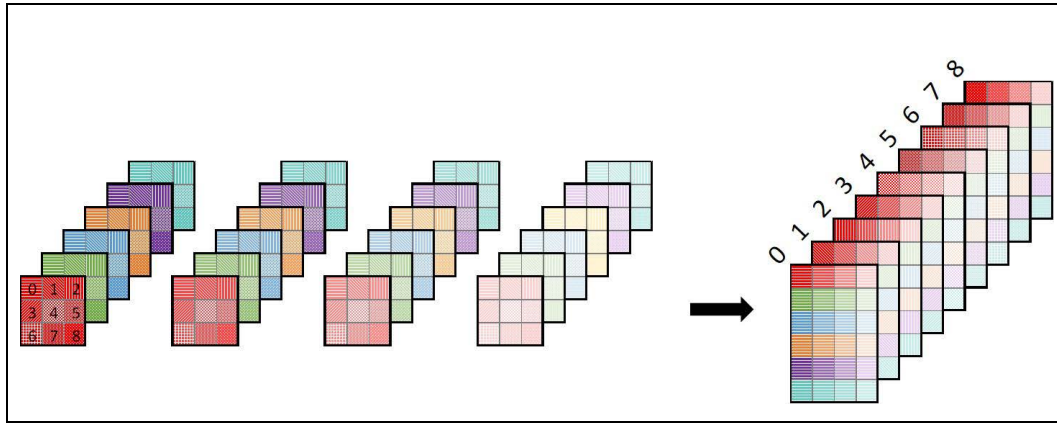

Figure 8-2. Transformed Weights

As a result, the convolution operation (see Figure 8-3),

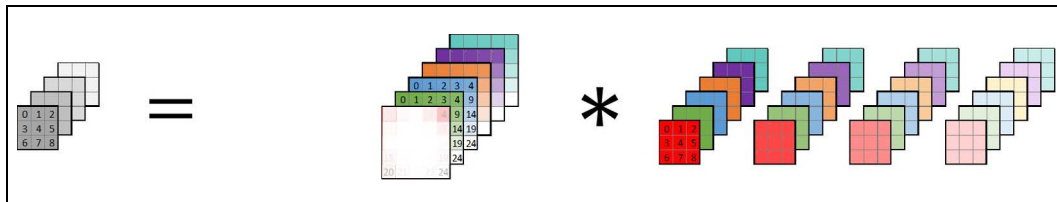

Figure 8-3. Convolution Operation

becomes a series of matrix multiplications and summations (see Figure 8-4).

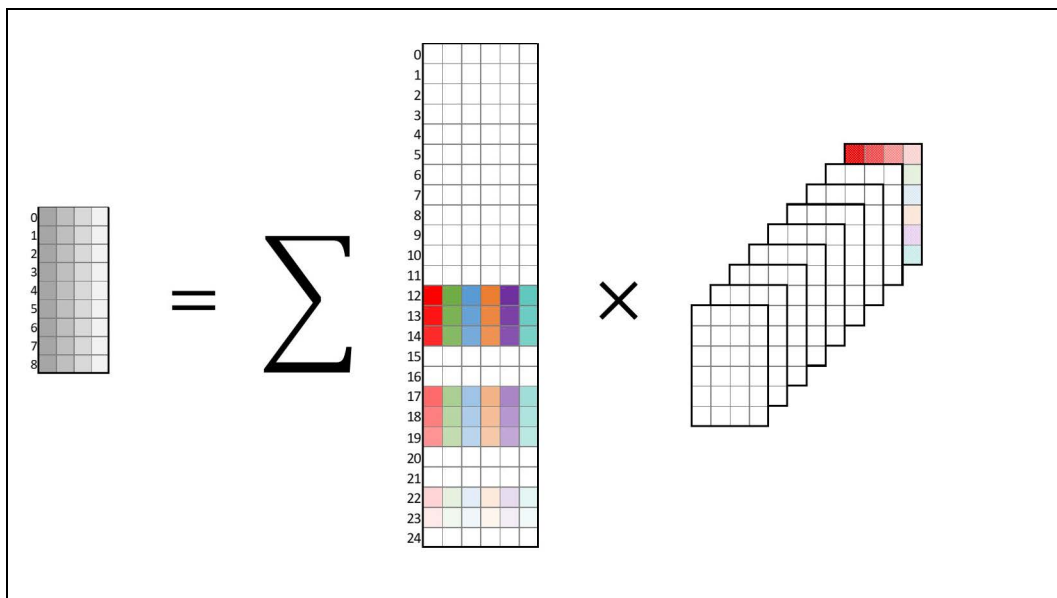

Figure 8-4. Matrix Multiplications and Summations

Matrix Multiplication

Matrix multiplication is performed in a standard manner (see Chapter 18, “Software Optimization for Intel® AVX-512 Instructions”).

Blocking

Since the matrices in question are generally large, one needs to traverse the matrices iteratively, while accumulating the results of the multiplication. Hence, one needs to allocate several registers (accumulators) to accumulate the results, and optionally have several registers for temporary caching of the A and B matrices, in order to enable reuse.

The order in which the matrices are traversed can have a monumental effect on the overall performance. In general, it is preferable to traverse the entire K dimension before moving on to the next element in the M or N dimension. When the K dimension is exhausted, the results in the accumulators are final (see discussion below about partial results). They can be fed to the post-convolution stage (See Post Convolution) and stored to the output location. If, however, the K dimension is not exhausted, before a move in the M or N dimension is initiated, the results in the accumulators are partial, i.e., they are the result of multiplication of some columns of A by some rows of B. These results have to be saved in an auxiliary buffer in order to free the accumulators for the new chunk of data. When we return to these M, N coordinates, these results have to be loaded from the buffer. Thus we perform additional store(s) and load(s) when compared to the exhaustive-K scenario. Furthermore, it is generally advisable to limit the advancement in the M or N dimension. Generally speaking, best results were obtained when the Accumulator K cache level of matrix B (see Figure 8-5) was in the DCU, and when the accumulative size of the cache blocks (see Figure 8-6) was as large as possible while still in MLC. However, there are cases where the best results are achieved when the accumulative size is much larger (even up to 3x of the MLC). These hyper-parameters are usually found by experimentation.

The “exhaustive-K” guideline does not yield optimal results in all cases, and the optimal extent of M,N locality should be determined on a case-by-case basis. We outline a simple yet effective way of structuring the control flow of the convolution process in order to accommodate the variety of scenarios abundant in modern CNNs.

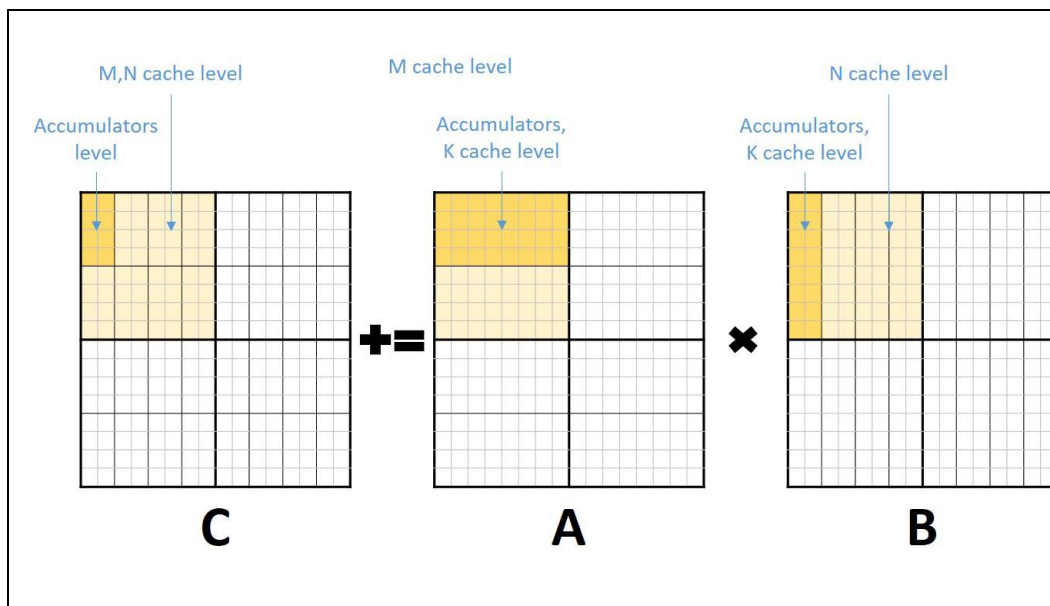

Figure 8-5. 3-Tier Flexible 2D Blocking

```

n = 0; // Rows of A,C (pixels) iterator
m = 0; // Cols of B,C (OFMs) iterator
k = 0; // Cols of A, rows of B (IFMs)
aC[N_ACCUMS][M_ACCUMS] = 0; // Accumulators of C

Matrices tiling by "cache blocks" [ while(n < N_END)
                                  while(m < M_END)
                                  while(k < K_END) ]
Partial convolution residing in caches [ for(ni = 0; ni < N_CACHE; ni += N_ACCUMS, n += N_ACCUMS)
                                       for(mi = 0; mi < M_CACHE; mi += M_ACCUMS, m += M_ACCUMS)
                                       for(ki = 0; ki < K_CACHE; ki++, k++) ]
Summation over kernel pixels [ for(kh = 0; kh < KERNEL_H; kh++)
                               for(kw = 0; kw < KERNEL_W; kw++) ]
Partial convolution filling accumulators [ for(n_acc = 0; n_acc < N_ACCUMS; n_acc++)
                                         for(m_acc = 0; m_acc < M_ACCUMS; m_acc++)
                                         aC[n_acc][m_acc] += A(m,k) * B(k,n); ]
store_partial_results(C(m,m_acc,n,n_acc), aC);
store_final_results(C(m,m_acc,n,n_acc), aC);

```

Not unrolled

Unrolling left to compiler's discretion

Always unrolled

Figure 8-6. 3-Tier Flexible 2D Blocking Loops

Direct Convolution Example

Consider a direct convolution with the following parameters:

IFM size = 34x34, KH = KW = 3, Convolution stride = 1, #IFMs = 32, #OFMs = 32, and the IFM is not padded. The size of the OFM is therefore 32x32.

The chosen blocking is M_ACCUMS = 4, N_ACCUMS = 2, M_CACHE = 1024, N_CACHE = 2, K_CACHE = 8. These blocking parameters ensure that the K dimension is traversed entirely and no temporary results need to be stored. Then, in order to compute 32 output channels for pixels (0,0), (0,1), (0,2) and (0,3) of the OFM, the following code can be employed.

Example 8-3. Direct Convolution

Direct Convolution		
vpxord	zmm0 , zmm0 , zmm0	// Zero accumulator tile [m,n] = [0,0]
vpxord	zmm1 , zmm1 , zmm1	// Zero accumulator tile [m,n] = [1,0]
vpxord	zmm2 , zmm2 , zmm2	// Zero accumulator tile [m,n] = [2,0]
vpxord	zmm3 , zmm3 , zmm3	// Zero accumulator tile [m,n] = [3,0]
vpxord	zmm4 , zmm4 , zmm4	// Zero accumulator tile [m,n] = [0,1]
vpxord	zmm5 , zmm5 , zmm5	// Zero accumulator tile [m,n] = [1,1]
vpxord	zmm6 , zmm6 , zmm6	// Zero accumulator tile [m,n] = [2,1]
vpxord	zmm7 , zmm7 , zmm7	// Zero accumulator tile [m,n] = [3,1]
for (int k = 0; k < 32 / 4; ++k) {		
vmovups	zmm12, zmmword ptr [WEIGHT_ADDR(kh=0,kw=0,k,n=0)]	// Load weights [kh,kw,n] = [0,0,+0]
vmovups	zmm13, zmmword ptr [WEIGHT_ADDR(kh=0,kw=0,k,n=1)]	// Load weights [kh,kw,n] = [0,0,+1]
vpbroadcastd	zmm8 , dword ptr [IFM_ADDR(0)]	// Load IFM pixel +0
vpbroadcastd	zmm9 , dword ptr [IFM_ADDR(1)]	// Load IFM pixel +1
vpbroadcastd	zmm10, dword ptr [IFM_ADDR(2)]	// Load IFM pixel +2
vpbroadcastd	zmm11, dword ptr [IFM_ADDR(3)]	// Load IFM pixel +3

Example 8-3. Direct Convolution (Contd.)

vdpbusd	zmm0 , zmm8 , zmm12	
vdpbusd	zmm1 , zmm9 , zmm12	
vdpbusd	zmm2 , zmm10 , zmm12	
vdpbusd	zmm3 , zmm11 , zmm12	
vmovups	zmm12, zmmword ptr [WEIGHT_ADDR(kh=0,kw=1,k,n=0)]	// Load weights [kh,kw,n] = [0,1,+0]
vdpbusd	zmm4 , zmm8 , zmm13	
vpbroadcastd	zmm8 , dword ptr [IFM_ADDR(4)]	// Load IFM pixel +4
vdpbusd	zmm5 , zmm9 , zmm13	
vdpbusd	zmm6 , zmm10 , zmm13	
vdpbusd	zmm7 , zmm11 , zmm13	
vmovups	zmm13, zmmword ptr [WEIGHT_ADDR(kh=0,kw=1,k,n=1)]	// Load weights [kh,kw,n] = [0,1,+1]
vdpbusd	zmm0 , zmm9 , zmm12	
vdpbusd	zmm1 , zmm10 , zmm12	
vdpbusd	zmm2 , zmm11 , zmm12	
vdpbusd	zmm3 , zmm8 , zmm12	
vmovups	zmm12, zmmword ptr [WEIGHT_ADDR(kh=0,kw=2,k,n=0)]	// Load weights [kh,kw,n] = [0,2,+0]
vdpbusd	zmm4 , zmm9 , zmm13	
vpbroadcastd	zmm9 , dword ptr [IFM_ADDR(5)]	// Load IFM pixel +5
vdpbusd	zmm5 , zmm10 , zmm13	
vdpbusd	zmm6 , zmm11 , zmm13	
vdpbusd	zmm7 , zmm8 , zmm13	
vmovups	zmm13, zmmword ptr [WEIGHT_ADDR(kh=0,kw=2,k,n=1)]	// Load weights [kh,kw,n] = [0,2,+1]
vdpbusd	zmm0 , zmm10 , zmm12	
vdpbusd	zmm1 , zmm11 , zmm12	
vdpbusd	zmm2 , zmm8 , zmm12	
vdpbusd	zmm3 , zmm9 , zmm12	
vmovups	zmm12, zmmword ptr [WEIGHT_ADDR(kh=1,kw=0,k,n=0)]	// Load weights [kh,kw,n] = [1,0,+0]
vdpbusd	zmm4 , zmm10 , zmm13	
vpbroadcastd	zmm10, dword ptr [IFM_ADDR(34)]	// Load IFM pixel +34
vdpbusd	zmm5 , zmm11 , zmm13	
vpbroadcastd	zmm11, dword ptr [IFM_ADDR(35)]	// Load IFM pixel +35
vdpbusd	zmm6 , zmm8 , zmm13	
vpbroadcastd	zmm8 , dword ptr [IFM_ADDR(36)]	// Load IFM pixel +36
vdpbusd	zmm7 , zmm9 , zmm13	
vmovups	zmm13, zmmword ptr [WEIGHT_ADDR(kh=1,kw=0,k,n=1)]	// Load weights [kh,kw,n] = [1,0,+1]
vpbroadcastd	zmm9 , dword ptr [IFM_ADDR(37)]	// Load IFM pixel +37
vdpbusd	zmm0 , zmm10 , zmm12	
vdpbusd	zmm1 , zmm11 , zmm12	
vdpbusd	zmm2 , zmm8 , zmm12	
vdpbusd	zmm3 , zmm9 , zmm12	
vmovups	zmm12, zmmword ptr [WEIGHT_ADDR(kh=1,kw=1,k,n=0)]	// Load weights [kh,kw,n] = [1,1,+0]
vdpbusd	zmm4 , zmm10 , zmm13	
vpbroadcastd	zmm10, dword ptr [IFM_ADDR(38)]	// Load IFM pixel +38
vdpbusd	zmm5 , zmm11 , zmm13	
vdpbusd	zmm6 , zmm8 , zmm13	
vdpbusd	zmm7 , zmm9 , zmm13	
vmovups	zmm13, zmmword ptr [WEIGHT_ADDR(kh=1,kw=1,k,n=1)]	// Load weights [kh,kw,n] = [1,1,+1]
vdpbusd	zmm0 , zmm11 , zmm12	
vdpbusd	zmm1 , zmm8 , zmm12	
vdpbusd	zmm2 , zmm9 , zmm12	
vdpbusd	zmm3 , zmm10 , zmm12	

Example 8-3. Direct Convolution (Contd.)

vmovups	zmm12, zmmword ptr [WEIGHT_ADDR(kh=1,kw=2,k,n=0)]	// Load weights [kh,kw,n] = [1,2,+0]
vpdpbusd	zmm4, zmm11, zmm13	
vpbroadcastd	zmm11, dword ptr [IFM_ADDR(39)]	// Load IFM pixel +39
vpdpbusd	zmm5, zmm8, zmm13	
vpdpbusd	zmm6, zmm9, zmm13	
vpdpbusd	zmm7, zmm10, zmm13	
vmovups	zmm13, zmmword ptr [WEIGHT_ADDR(kh=1,kw=2,k,n=1)]	// Load weights [kh,kw,n] = [1,2,+1]
vpdpbusd	zmm0, zmm8, zmm12	
vpdpbusd	zmm1, zmm9, zmm12	
vpdpbusd	zmm2, zmm10, zmm12	
vpdpbusd	zmm3, zmm11, zmm12	
vmovups	zmm12, zmmword ptr [WEIGHT_ADDR(kh=2,kw=0,k,n=0)]	// Load weights [kh,kw,n] = [2,0,+0]
vpdpbusd	zmm4, zmm8, zmm13	
vpbroadcastd	zmm8, dword ptr [IFM_ADDR(68)]	// Load IFM pixel +68
vpdpbusd	zmm5, zmm9, zmm13	
vpbroadcastd	zmm9, dword ptr [IFM_ADDR(69)]	// Load IFM pixel +69
vpdpbusd	zmm6, zmm10, zmm13	
vpbroadcastd	zmm10, dword ptr [IFM_ADDR(70)]	// Load IFM pixel +70
vpdpbusd	zmm7, zmm11, zmm13	
vmovups	zmm13, zmmword ptr [WEIGHT_ADDR(kh=2,kw=0,k,n=1)]	// Load weights [kh,kw,n] = [2,0,+1]
vpbroadcastd	zmm11, dword ptr [IFM_ADDR(71)]	// Load IFM pixel +71
vpdpbusd	zmm0, zmm8, zmm12	
vpdpbusd	zmm1, zmm9, zmm12	
vpdpbusd	zmm2, zmm10, zmm12	
vpdpbusd	zmm3, zmm11, zmm12	
vmovups	zmm12, zmmword ptr [WEIGHT_ADDR(kh=2,kw=1,k,n=0)]	// Load weights [kh,kw,n] = [2,1,+0]
vpdpbusd	zmm4, zmm8, zmm13	
vpbroadcastd	zmm8, dword ptr [IFM_ADDR(72)]	// Load IFM pixel +72
vpdpbusd	zmm5, zmm9, zmm13	
vpdpbusd	zmm6, zmm10, zmm13	
vpdpbusd	zmm7, zmm11, zmm13	
vmovups	zmm13, zmmword ptr [WEIGHT_ADDR(kh=2,kw=1,k,n=1)]	// Load weights [kh,kw,n] = [2,1,+1]
vpdpbusd	zmm0, zmm9, zmm12	
vpdpbusd	zmm1, zmm10, zmm12	
vpdpbusd	zmm2, zmm11, zmm12	
vpdpbusd	zmm3, zmm8, zmm12	
vmovups	zmm12, zmmword ptr [WEIGHT_ADDR(kh=2,kw=2,k,n=0)]	// Load weights [kh,kw,n] = [2,2,+0]
vpdpbusd	zmm4, zmm9, zmm13	
vpbroadcastd	zmm9, dword ptr [IFM_ADDR(73)]	// Load IFM pixel +73
vpdpbusd	zmm5, zmm10, zmm13	
vpdpbusd	zmm6, zmm11, zmm13	
vpdpbusd	zmm7, zmm8, zmm13	
vmovups	zmm13, zmmword ptr [WEIGHT_ADDR(kh=2,kw=2,k,n=1)]	// Load weights [kh,kw,n] = [2,2,+1]
vpdpbusd	zmm0, zmm10, zmm12	
vpdpbusd	zmm1, zmm11, zmm12	
vpdpbusd	zmm2, zmm8, zmm12	
vpdpbusd	zmm3, zmm9, zmm12	
vpdpbusd	zmm4, zmm10, zmm13	

Example 8-3. Direct Convolution (Contd.)

```

vpdpbusd    zmm5 , zmm11, zmm13
vpdpbusd    zmm6 , zmm8 , zmm13
vpdpbusd    zmm7 , zmm9 , zmm13
}
// Do post-processing operations with results in zmm0-zmm7

```

In this code we allocate M_ACCUM (4) zmm registers zmm8-zmm11 for IFM values, and N_ACCUM (2) zmm registers zmm12-zm13 for weights.

In the beginning the accumulators must be zeroed out. Then the entire K dimension (#IFMs=32) must be traversed, each iteration operating on 4 consecutive IFMs. The convolution consists from a series of 4-byte broadcasts of IFM data, 64-byte loads of weights data, and multiplication and accumulation operations. Due to the large IFM data overlap between different kh,kw values, the IFM data can be efficiently reused, and the number of data loads significantly lowered.

8.4.1.2 Convolutional Layers with Low OFM Count

Vectorization along the channel dimension works well when there are enough channels (both input and output) to fill up the vector registers, which is usually the case with classification topologies. However, in some cases such as Generative Adversarial Networks (GANs) the end result is an image which means that last convolutional layer has only three channels. In this layer it makes more sense to vectorize along the spatial dimension, which requires a different layout of data. To avoid a large intermediate buffer we re-layout the computation on the fly for one 4x16 block, perform a partial convolution, and throw the block away (this mechanism is limited for 1x1 kernels and assumes the weights have been reordered to match the new layout).

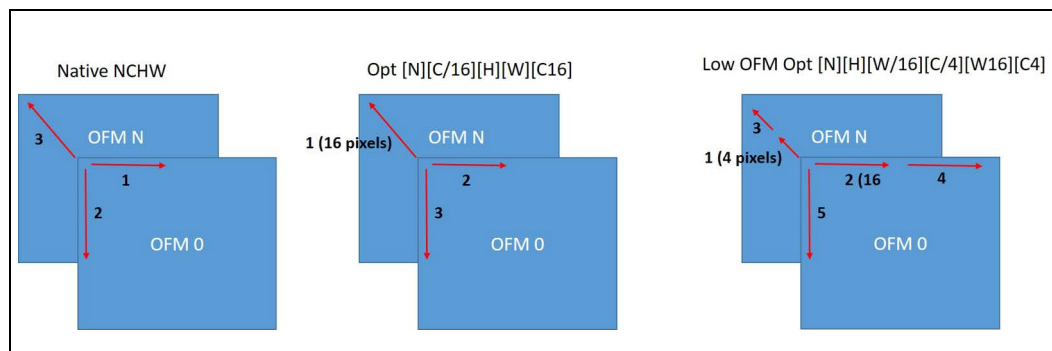

Figure 8-7. Standard vs Optimized vs. Low OFM Optimized Data Layouts¹

NOTES:

1. The 4x16 blocks of the Low OFM optimization are created on the fly and used only once.

Example 8-4. Convolution for Layers with Low OFM Count

```

Convolution for Layers with Low OFM Count

# IFM_W % 16 == 0
# NUM_OFMS = 3
# NUM_IFMS = 64
# dqfs - array of dequantization factors for the down convert

int src_ifm_size = IFM_H * IFM_W * IFMBlock;
int ofm_size = IFM_W * IFM_H;

__m512i gather_indices = _mm512_setr_epi32(0, 4, 8, 12, 16, 20, 24, 28, 32, 36, 40, 44, 48, 52, 56, 60);

__m512 dqf_broadcast[NUM_OFMS];

#pragma unroll(NUM_OFMS)
for (int ofm = 0 ; ofm < NUM_OFMS ; ofm++) {
    dqf_broadcast[ofm] = _mm512_set1_ps(dqfs[ofm]);
}

for (int h = 0 ; h < IFM_H ; h++) {
    int src_line_offset = h * IFM_W * IFMBlock;
    int w = 0;
    int src_w_offset = src_line_offset;
    for ( ; w < IFM_W ; w += 16) {
        __m512i res_i32[NUM_OFMS] = { 0 };

        // Convolve 4x16 OFMs by reorganizing on the fly.
        for (int ifm = 0 ; ifm < NUM_IFMS ; ifm += 4) {
            int src_block_offset = ifm & 0xf;
            int src_ifm_index = ifm >> 4;
            size_t src_ifm_offset = src_w_offset + src_ifm_index * src_ifm_size + src_block_offset;
            __m512i ivec = _mm512_i32gather_epi32(gather_indices, input + src_ifm_offset, 4);
            #pragma unroll(NUM_OFMS)
            for (int ofm = 0 ; ofm < NUM_OFMS ; ofm++) {
                int weight_offset = (ofm * NUM_IFMS + ifm) * 16;
                __m512i wvec = _mm512_load_si512(weights_reorged + weight_offset);
                res_i32[ofm] = _mm512_dpbusd_epi32(res_i32[ofm], ivec, wvec);
            }
        }
        // Down convert and store results in native layout.
        #pragma unroll(NUM_OFMS)
        for (int ofm = 0 ; ofm < NUM_OFMS ; ofm++) {
            __m512 res_f32 = _mm512_cvtepi32_ps(res_i32[ofm]);
            res_f32 = _mm512_mul_ps(res_f32, dqf_broadcast[ofm]);
            size_t output_offset = ofm * ofm_size + h * IFM_W + w;
            _mm512_store_ps(output + output_offset, res_f32);
        }
        src_w_offset += 16 * IFMBlock;
    }
}
}
}

```

8.4.2 Post Convolution

Numerous transformations may be operated on the layer data once the convolution is done. These may include classical post convolution operations such as ReLU, operations that are usually considered a separate layer such as pooling or EltWise, and quantization/dequantization operations. To reduce memory hierarchy thrashing, try to do these steps during the convolution (i.e., fused into the convolution computation). Fusing the quantization step is especially attractive because it gains 4x compute bandwidth and reduces memory bandwidth 4x.

8.4.2.1 Fused Quantization/Dequantization

Section 8.3.2.1 describes how to do offline quantization. Typically however, the dequantization of the current layer and the quantization for the next layer can be fused to the convolution step. The following code describes the basic operation of the post-convolution step which is initiated once the convolution of a block of OFMs was finished. As before, the procedure operates on 16 int8 OFMs belonging to the same pixel. In this example we assume that the dequantization factors (and bias if any) were prepared so that a single factor represents the dequantization of the current layer and then the requantization to the next layer. Generally speaking we try to reduce the number of online computations by representing several multiplication factors, e.g., dequantization, layer constant multiplication value, and quantization, to the next layer as a single factor. In addition, if the original OFMs could have been negative (no ReLU) we follow the procedure of Section 8.3.2.1 and add 127 to all the values.

Example 8-5. Basic PostConv

```

Basic PostConv

//dest points to a vector of 16 OFMSs belonging to the same pixel.
uint8_t* dest = (uint8_t*) (outputFeatureMaps) + offset;

// in are the 16 accumulators in int32 that we need to operate on.
__m512 resf = _mm512_cvtepi32_ps(in); // Convert to float

// add bias if there is one and then dequantize + requantize in a single step
if (bias) {
    resf = _mm512_fmadd_ps(resf,
        _mm512_load_ps(dqfs + OFMChannelOffset),
        _mm512_load_ps((__m512*) (bias + OFMChannelOffset)));
} else {
    resf = _mm512_mul_ps(resf,
        _mm512_load_ps(dqfs + OFMChannelOffset));
}

#ifdef RELU
    resf = _mm512_max_ps(resf, broadcast_zero);
#endif

// at this point we are in the uint8 range.
__m512i res = _mm512_cvt_roundps_epi32(resf, _MM_FROUND_TO_NEAREST_INT|_MM_FROUND_NO_EXC);
__m128i res8;

#ifdef ELTWISE
    /* fused Eltwise ops */
#else
    # if !IRELU
        res = _mm512_add_epi32(res, _mm512_set1_epi32(128));
    # endif
    res8 = _mm512_cvtusepi32_epi8(res);
#endif // ELTWISE

#ifdef POOLING
    /* fused pooling ops */
#endif

_mm_store_si128((__m128i*) dest, res8);

```

8.4.2.2 ReLU

ReLU is implemented as a max with a zero register with negligible overhead as it fused with the convolution.

8.4.2.3 EltWise

Element wise operations are usually easier to fuse into the convolution step because they operate directly on the accumulators just before the final result is saved. Note, however, that the quantization factors of the different input layers are usually not the same so the inputs must first be dequantized to f32, operated on and then quantized again (we show an optimization for this step in the vectorized code).

The following example of the eltwise operation required given the data type of the inputs and outputs. In all the examples it is assumed that the data from the convolutional operation is the INT32 data returned from the VPDPBUSD operation, and that the quantized output must be uint8, even though in some cases the unquantized output could be negative. See Section 8.3.2, "Quantization" on how quantization to uint8 works with negative values.

The following optimized code shows eltwise implementations for several eltwise use cases assuming that "dest" points to a vector of 16 OFMs belonging to the same pixel in the output. In principle we need to dequantize the eltwise data and the convolution data, do the addition and then dequantize, as in the following equation.

$$result = (eltwise_{f32} \times eltwiseDQfactor + conv_{i32} \times convDQfactor) \times NextQfactor$$

However, we can pre-process the factors offline (operations in square brackets) so that we have only two multiplications online.

$$result = \left(eltwise_{f32} + conv_{i32} \left[\frac{convDQfactor}{eltwiseDQfactor} \right] \right) \times [NextQfactor \times eltwiseDQfactor]$$

Example 8-6. Uint8 Residual Input

Uint8 Residual Input
<pre> __m128i eltwise_u8 = _mm_load_si128((const __m128i*) (eltwise_data + ew_offset)); __m512i eltwise_i32 = _mm512_cvtepu8_epi32(eltwise_u8); if (signed_residual) { eltwise_i32 = _mm512_sub_epi32(eltwise_i32, broadcast_128); } __m512 eltwise_f32 = _mm512_cvtepi32_ps(eltwise_i32); resf = _mm512_add_ps(eltwise_f32, resf); /* add with conv results */ /* dequantization and then requantization to next layer in one op */ resf = _mm512_mul_ps(resf, broadcast_fused_eltwise_out_qfactor); if (relu) resf = _mm512_max_ps(resf, broadcast_zero); __m512i data_i32 = _mm512_cvt_roundps_epi32(resf, (_MM_FROUND_TO_NEAREST_INT _MM_FROUND_NO_EXC)); res8 = _mm512_cvtusepi32_epi8(data_i32); if (!relu) { res8 = _mm_add_epi8(res8, _mm_set1_epi8(-128)); //hack to add 128 } </pre>

8.4.2.4 Pooling

Pooling layers may not be simple to fuse to the convolution step but in some cases the fusion is easy. The average pooling of the last convolutional layer of Inception ResNet 50 for example amounts to averaging

all the 8x8 pixels of every OFM channel into a single value, thus emitting a single value per OFM. Such an operation is easy to fuse because it behaves the same for every pixel.

Example 8-7. 8x8 Average Pooling with Stride 1 of 8x8 Layers

8x8 Average Pooling with Stride 1 of 8x8 Layers
<pre> __m512 pool_factor = _mm512_set1_ps((float)1.0/64); // resf is the 16 float values as computed in Basic PostConv code sample resf = _mm512_mul_ps(resf, pool_factor); // divide by 64 // The pool offset depends only on the current OFM (OFMltr). int pool_offset = (BlockOffsetOFM + OFMltr); float *pool_dest = (float *) (outputFeatureMaps) + pool_offset; __m512 prev_val = _mm512_load_ps((const __m512 *) (pool_dest)); __m512 res_tmp_ps = _mm512_add_ps(resf, prev_val); __mm512_store_ps((__m512 *) pool_dest, res_tmp_ps); </pre>

The following unfused vectorized code can be used to do max and average pooling. In the example below the pooling step can also adjust the input quantization range to the output quantization range. This is usually necessary before a concat layer, which is implemented as a No-Op, which means that the output quantization range of all the concatenated layers must be the same.

Example 8-8. Unfused Vectorized Pooling

Unfused Vectorized Pooling
<pre> // We concurrency pool 16 IFMs before moving to the next set of IFMs for (int ifm = 0; ifm < no_ifm; ifm+=16) { // Find the location of the block in the input and in the output that we are pooling int block_idx = (ifm >> 4); size_t block_offset = (spatial_size_in * block_idx) << 4; size_t block_offset_out = (spatial_size_out * block_idx) << 4; for (int y = -pad_h_; y < top_y + pad_h_; y++) { int y_offset_out = (top_x * 16 * (y + pad_h_)); for (int x = -pad_w_; x < top_x + pad_w_; x++) { __m256i res_pixel = _mm256_set1_epi16(0); //should be u_int but 0 is 0 for (int i = 0; i < kernel_w; i++) { int y_offset_in = (bottom_x * (i + (y * stride)))<<4; for (int j = 0; j < kernel_h; j++) { int x_offset = (j + (x * stride)) << 4; // skip pixels that are inside the pad if (pad && ((j + (x * stride)) < 0 (i + (y * stride)) < 0)) continue; //load pixel data </pre>

Example 8-8. Unfused Vectorized Pooling (Contd.)

```

    __m128i data_px = _mm_load_si128((const __m128i *) (bottom_data+ ifm_image_offset + block_offset +
    y_offset_in + x_ofsset ));
    // convert to u16 for average.
    __m256i data_px_u16 = _mm256_cvtepu8_epi16(data_px);
    if (MAX) {
        res_pixel = _mm256_max_epu16(res_pixel,data_px_u16);
    } else if (AVERAGE) {
        res_pixel = _mm256_adds_epu16(res_pixel,data_px_u16);
    }
    } // kernel_h
} // kernl_w

// done with the input data but there may be some adjustments necessary.
int x_offset_out = (x + pad_w_) << 4;
if (SHOOUL_ADJUST_QUANTIZATION_RANGE) { // typically before a no-op concat
    float factor = layer_param().quantization_param().bottom_range()
        / this->layer_param().quantization_param().top_range();

    __m512 broadcast_factor = _mm512_set1_ps(factor);

    __m512i res_pixel_i32 = _mm512_cvtepu16_epi32(res_pixel);
    __m512 res_pixel_f32 = _mm512_cvtepi32_ps(res_pixel_i32);
    res_pixel_f32 = _mm512_mul_ps(res_pixel_f32,broadcast_factor);

    __m512i data_i32 = _mm512_cvt_roundps_epi32 (res_pixel_f32 ,_MM_FROUND_TO_NEAR-
EST_INT|_MM_FROUND_NO_EXC);
    res_pixel= _mm512_cvtusepi32_epi16(data_i32);

}
if (AVERAGE) {
    uint8_t kernel_size_u8 = kernel_h_ * kernel_w_;
    __m256i broadcast_kernel_size = _mm256_set1_epi16(kernel_size_u8);

    res_pixel=_mm256_div_epu16(res_pixel,broadcast_kernel_size);
}
// compute final offset and save
uint8_t * total_offset =
    top_data + output_image_offset + layer_offset + block_offset_out +
    y_ofsset_out + x_ofsset_out ;//+ vect_idx;
    _mm_store_si128((__m128i*) total_offset, _mm256_cvtepu16_epi8(res_pixel));
}
}
}

```

8.4.2.5 Pixel Shuffler

The SRGAN topology includes a layer that reshapes the inputs as follows.

1. The width and height of the features maps are doubled.
2. The number of output feature maps is divided by four.

Every 2x2 quad in the output feature map is populated by four pixels from the same spatial dimensions in the input which satisfy the condition that $(c \bmod K/4)$ is the same where c is the input channel and K is the number of input feature maps (reference paper SRGAN).

Example 8-9. Caffe Scalar Code for Pixel Shuffler

```

Caffe Scalar Code for Pixel Shuffler
void pixel_shuffler(const vector<int>& bottom_shape, const vector<int>& top_shape, const pstype* bottom_data,
                  pstype* top_data)
{
  const int N = bottom_shape[0];
  assert(N == top_shape[0]);
  const int bc = bottom_shape[1];
  const int bh = bottom_shape[2];
  const int bw = bottom_shape[3];
  const int tc = top_shape[1];
  const int th = top_shape[2];
  const int tw = top_shape[3];
  const int r = th / bh;
  int bottom_ch_size = bw * bh;
  int top_ch_size = tw * th;
  pstype* cur_channel = NULL;
  for(int n = 0; n < N; n++){
    const pstype* src = bottom_data + n * bc * bottom_ch_size;
    pstype* dst = top_data + n * tc * top_ch_size;
    for(int c = 0; c < tc; c++){
      cur_channel = dst + c * top_ch_size;
      for(int h = 0; h < bh; h++){
        for(int w = 0; w < bw; w++){
          int bottom_offset = h * bw + w;
          int bottom_index = c * bottom_ch_size + bottom_offset;
          int top_index = h * r * tw + w * r;
          cur_channel[top_index] = src[bottom_index]; // top left
          bottom_index = (c + tc) * bottom_ch_size + bottom_offset;
          top_index = h * r * tw + w * r + 1;
          cur_channel[top_index] = src[bottom_index]; // top right
          bottom_index = (c + 2 * tc) * bottom_ch_size + bottom_offset;
          top_index = (h * r + 1) * tw + w * r;
          cur_channel[top_index] = src[bottom_index]; // bottom left
          bottom_index = (c + 3 * tc) * bottom_ch_size + bottom_offset;
          top_index = (h * r + 1) * tw + w * r + 1;
          cur_channel[top_index] = src[bottom_index]; // bottom right
        }
      }
    }
  }
}

```

Because of the memory layout of the vectorized directConv, it is easy to fuse the pixel shuffler layer to the convolution. The only change that is required is to save the result of the convolution in the correct place in the output.

Example 8-10. Computing Output Offset for Fused Pixel Shuffler

Computing Output Offset for Fused Pixel Shuffler
<pre>// base_ofm - output target location (base_ofm % 16 == 0) // SubTileX - X location in quad (0 or 1) // SubTileY - Y location in quad (0 or 1) // ConvOutputX - X position in the output of the convolution // ConvOutputY - Y position in the output of the convolution int PostPSNoOutMs =(NoOutFMs / 4); int PostPSOptOfmIndex = (base_ofm % PostPSNoOutMs) / 16; int QuarterIndex = base_ofm / PostPSNoOutMs; int SubTileX = QuarterIndex & 0x1; int SubTileY = (QuarterIndex & 0x2) >> 1; int PostPSX = ConvOutputX * 2 + SubTileX; int PostPSY = ConvOutputY * 2 + SubTileY; size_t offset = (OFM_H * OFM_W * PostPSOptOfmIndex + PostPSY * OFM_W + PostPSX) * 16;</pre>

8.5 LSTM NETWORKS

Long short-term memory (LSTM) units are used to create Recurrent Neural Networks (RNNs) for tasks such as speech and text translation. The fundamental computation of an LSTM cell is matrix multiplication (GEMM), not direct convolution, as in CNNs.

8.5.1 Fused LSTM Embedding

The LSTM cell starts by multiplying the input data by the input kernel where the input data (a.k.a embedding) are 512 elements for every dictionary word and the input kernel is known offline and never changes. Finally, each embedding vector is multiplied by the same matrix. It has been suggested¹ to multiply each vector by the kernel offline and save the result, and at runtime lookup the GEMM result by the word index and copy into the accumulator area of the cell. This optimization may give an approximate 20% performance boost.

8.5.2 Fused post GEMM

Many variants of existing LSTM cells contain transcendental operations such as sigmoid and hyperbolic tangent as activation functions.

$$\text{sigmoid}(x) = \frac{1}{e^{-x} + 1}$$

$$\text{tanh}(x) = \frac{e^x - e^{-x}}{e^x + e^{-x}}$$

Implementing the activation part as full precision scalar or SMVL-based vectorized code may be slow. The alternative is to use approximations which provide good performance. One of the approaches for approximating transcendental functions is to use piece-wise polynomial approximations.

1. Jacob Devlin, Rabih Zbib, Zhongqiang Huang, Thomas Lamar, Richard M Schwartz, and John Makhoul. 2014. Fast and robust neural network joint models for statistical machine translation. In ACL (1). Citeseer, pages 1370-1380.

Example 8-11. Sigmoid Approximation with Minimax Polynomials

```

Sigmoid Approximation with Minimax Polynomials
// clang-format off

//coefficients of second order minimax polynomial for sigmoid approximation
__declspec( align(64) ) const float sigmoid_poly2_coeffs[3][16] = {
{
    0.559464f, 0.702775f, 0.869169f, 0.968227f, 0.996341f, 0.999999f, 0.499999f, 0.499973f,
    0.499924f, 0.499791f, 0.499419f, 0.498471f, 0.496119f, 0.491507f, 0.486298f, 0.495135f,
},
{
    0.22038f, 0.123901f, 0.042184f, 0.00779019f, 0.000651011f, 1.12481e-7f, 0.250103f, 0.250739f,
    0.251492f, 0.252905f, 0.255751f, 0.260808f, 0.269823f, 0.282225f, 0.292552f, 0.281425f,
},
{
    -0.0298035f, -0.0135297f, -0.00347128f, -0.000483042f, -0.0000289636f, -2.57464e-9f, -0.00292674f,
    -0.00680854f, -0.00968539f, -0.0134544f, -0.0188995f, -0.0256562f, -0.0343136f, -0.0426696f, -0.0478004f,
    -0.0443023f,
},
},
};

// clang-format on

inline void sigmoid_poly_2(const __m512& arg, __m512& func)
{
    // Load polynomial coefficients into registers (one time operation)
    const __m512 sigmoid_coeff0 = _mm512_load_ps( sigmoid_poly2_coeffs[0] );
    const __m512 sigmoid_coeff1 = _mm512_load_ps( sigmoid_poly2_coeffs[1] );
    const __m512 sigmoid_coeff2 = _mm512_load_ps( sigmoid_poly2_coeffs[2] );

    // Extract signs of args
    const __m512 ps_sign_filter = _mm512_castsi512_ps(_mm512_set1_epi32( 0x7FFFFFFF ));

    __mmask16 signs = _mm512_movepi32_mask(_mm512_castps_si512(arg));
    __m512 abs_arg = _mm512_and_ps(arg, ps_sign_filter);

    // Compute approximation intervals out of args' exponent and MSB and
    // restrict number of intervals to 16
    const __m512i lut_low = _mm512_set1_epi32( 246 );
    const __m512i lut_high = _mm512_set1_epi32( 261 );

    __m512i indices = _mm512_srli_epi32(_mm512_castps_si512(abs_arg), 22);
    indices = _mm512_max_epi32(indices, lut_low);
    indices = _mm512_min_epi32(indices, lut_high);

    /*
    * Approximate
    */
    __m512 func_p0 = _mm512_permutexvar_ps(indices, sigmoid_coeff0);
    __m512 func_p1 = _mm512_permutexvar_ps(indices, sigmoid_coeff1);
    __m512 func_p2 = _mm512_permutexvar_ps(indices, sigmoid_coeff2);
}

```

Example 8-11. Sigmoid Approximation with Minimax Polynomials (Contd.)

```

func = _mm512_fmadd_ps(abs_arg, func_p2, func_p1);
func = _mm512_fmadd_ps(abs_arg, func, func_p0);

// Account for args' sign
const __m512 ps_ones = _mm512_set1_ps( 1.0 );
func = _mm512_mask_sub_ps(func, signs, ps_ones, func);
}

```

While the minimax polynomial approximation may show the best accuracy on a layer-by-layer basis, the end-to-end accuracy may suffer in some topologies (NMT notably). In such cases a different approach might be better. The following approximation uses the fact that

$$e^x = 2^{x \log_2 e} = 2^{n+y}$$

Where

$$n = \text{round}(x \log_2 e)$$

$$y = x \log_2 e - n$$

2^n is computed by the scalef instruction

$$2^n = \text{scalef}(x \log_2 e)$$

2^y can be approximated sufficiently well by a Taylor Polynomial of degree 2.

Example 8-12. Sigmoid Approximation with scalef

```

Sigmoid Approximation with scalef

const __m512 ps_ones = _mm512_set1_ps( 1.0 );
const __m512 half = _mm512_set1_ps( 0.5f );
const __m512 minus_log2_e = _mm512_set1_ps( -1.442695f );
const __m512 ln2sq_over_2 = _mm512_set1_ps( 0.240226507f );
const __m512 ln2__ln2sq_over_2 = _mm512_set1_ps( 0.452920674f );
const __m512 one__ln2sq_over_8 = _mm512_set1_ps( 0.713483036f );

inline void sigmoid_scalef(const __m512& arg, __m512& func)
{
    __m512 x = _mm512_fmadd_ps(arg, minus_log2_e, half);
    __m512 y = _mm512_reduce_ps(x, 1);
    __m512 _2y = _mm512_fmadd_ps(_mm512_fmadd_ps(y, ln2sq_over_2, ln2__ln2sq_over_2), y, one__ln2sq_over_8);
    __m512 exp = _mm512_scalef_ps(_2y, x);
    func = _mm512_rcp14_ps(_mm512_add_ps(exp, ps_ones));
}

```

8.5.3 Dynamic Batch Size

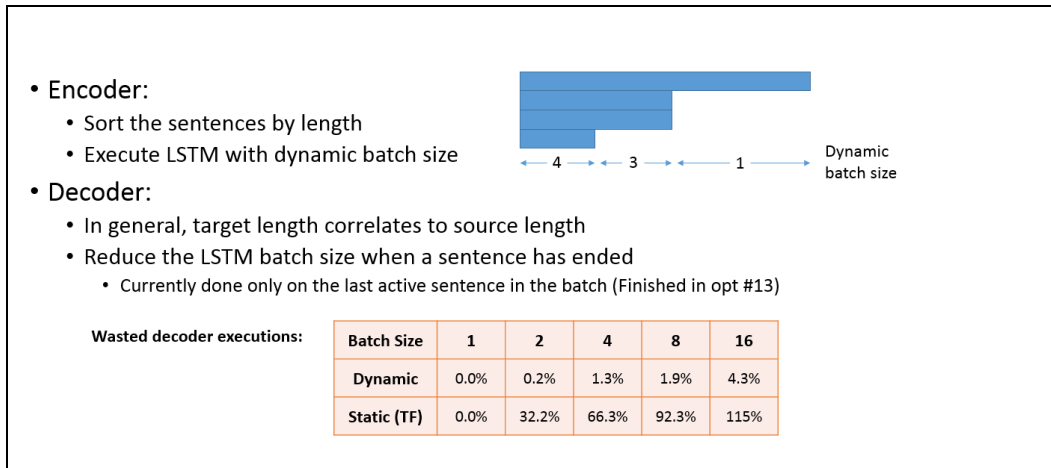

Figure 8-8. Dynamic Batch Size¹

NOTES:

- NMT can gain significantly by adapting the computation in each iteration to the number of sentences that are still active.

Different RNN objects, e.g., sentences, can require very different computation effort, e.g., short sentence vs long sentence. When batching multiple objects together, it is important take this fact into consideration to avoid unnecessary computations. In NMT for example (see Figure 8-8), if we ensure sentences are ordered by length it is easy to adapt each iteration to the actual number of active sentences.

8.5.4 NMT Example: Beam Search Decoder Get Top K

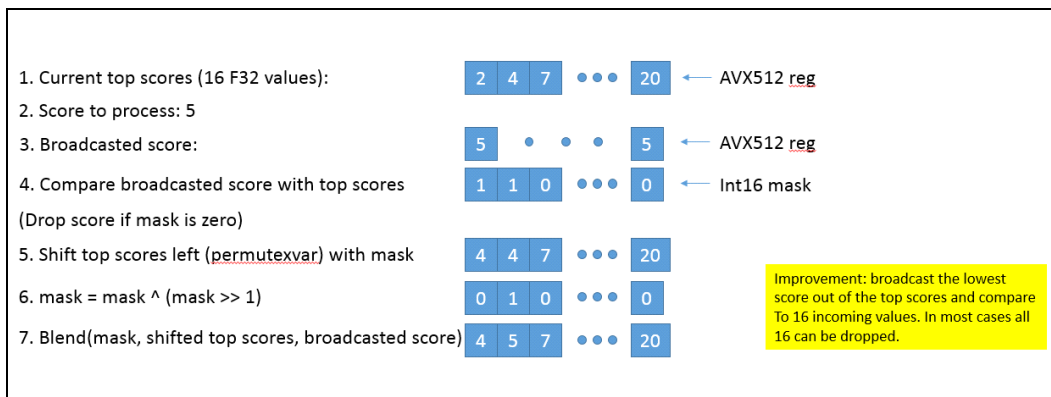

Figure 8-9. Find Top 16 Values in Some Input

In Neural Machine Translation, as presented in <https://papers.nips.cc/paper/5346-sequence-to-sequence-learning-with-neural-networks.pdf> and <https://github.com/tensorflow/nmt>, a significant amount of time is spent searching for the current top BEAM_WIDTH attention scores out of BEAM_WIDTH*VOCAB_SIZE values, which could be very large. We suggest using the following algorithm to optimize this step. The crux of the process is that a new value can be concurrently compared against all the current top values in one op (see Figure 8-9, line 4). Note that we keep the top scores sorted so the mask returned by the op must consist of a sequence of ones followed by a sequence zeros (1*0*).

Example 8-13. Pseudocode for Finding Top K

Pseudocode for Finding Top K
<pre> // ZMM0 - best scores, initialized to -MAX_FLOAT // ZMM1 - indices of best scores // ZMM4 - index the current score index = 0 pxor ZMM4 while index < MAX_DATA vbroadcastss ZMM2, array[index] VPCMPSS K1,ZMM0,ZMM2, _CMP_LT_OQ KTESTW K1,K1 JZ ... // K1 == 0 so we can just put new score first //if K1!=0 VPERMPS ZMM0(k1),ZMM0 VPERMPS ZMM1(k1),ZMM0 KSHIFT k2,k1,1 KXOR k3,k2,k1 VPBLENDMPS k3, ZMM0,ZMM2 VPBLENDMD k3, ZMM1,ZMM4 VPADD ZMM4, 1 add index, 1 </pre>

Over the past decade, processor speed has increased. Memory access speed has increased at a slower pace. The resulting disparity has made it important to tune applications in one of two ways: either (a) a majority of data accesses are fulfilled from processor caches, or (b) effectively masking memory latency to utilize peak memory bandwidth as much as possible.

Hardware prefetching mechanisms are enhancements in microarchitecture to facilitate the latter aspect, and will be most effective when combined with software tuning. The performance of most applications can be considerably improved if the data required can be fetched from the processor caches or if memory traffic can take advantage of hardware prefetching effectively.

Standard techniques to bring data into the processor before it is needed involve additional programming which can be difficult to implement and may require special steps to prevent performance degradation. Streaming SIMD Extensions addressed this issue by providing various prefetch instructions.

Streaming SIMD Extensions introduced the various non-temporal store instructions. SSE2 extends this support to new data types and also introduce non-temporal store support for the 32-bit integer registers.

This chapter focuses on:

- Hardware Prefetch Mechanism, Software Prefetch and Cacheability Instructions — Discusses microarchitectural feature and instructions that allow you to affect data caching in an application.
- Memory Optimization Using Hardware Prefetching, Software Prefetch and Cacheability Instructions — Discusses techniques for implementing memory optimizations using the above instructions.
- Using deterministic cache parameters to manage cache hierarchy.

9.1 GENERAL PREFETCH CODING GUIDELINES

The following guidelines will help you to reduce memory traffic and utilize peak memory system bandwidth more effectively when large amounts of data movement must originate from the memory system:

- Take advantage of the hardware prefetcher's ability to prefetch data that are accessed in linear patterns, in either a forward or backward direction.
- Take advantage of the hardware prefetcher's ability to prefetch data that are accessed in a regular pattern with access strides that are substantially smaller than half of the trigger distance of the hardware prefetch.
- Facilitate compiler optimization by:
 - Minimize use of global variables and pointers.
 - Minimize use of complex control flow.
 - Use the const modifier, avoid register modifier.
 - Choose data types carefully (see below) and avoid type casting.
- Use cache blocking techniques (for example, strip mining) as follows:
 - Improve cache hit rate by using cache blocking techniques such as strip-mining (one dimensional arrays) or loop blocking (two dimensional arrays).
 - Explore using hardware prefetching mechanism if your data access pattern has sufficient regularity to allow alternate sequencing of data accesses (for example: tiling) for improved spatial locality. Otherwise use PREFETCHNTA.
- Balance single-pass versus multi-pass execution:
 - Single-pass, or unlayered execution passes a single data element through an entire computation pipeline.

- Multi-pass, or layered execution performs a single stage of the pipeline on a batch of data elements before passing the entire batch on to the next stage.
- If your algorithm is single-pass use PREFETCHNTA. If your algorithm is multi-pass use PREFETCHT0.
- Resolve memory bank conflict issues. Minimize memory bank conflicts by applying array grouping to group contiguously used data together or by allocating data within 4-KByte memory pages.
- Resolve cache management issues. Minimize the disturbance of temporal data held within processor's caches by using streaming store instructions.
- Optimize software prefetch scheduling distance:
 - Far ahead enough to allow interim computations to overlap memory access time.
 - Near enough that prefetched data is not replaced from the data cache.
- Use software prefetch concatenation. Arrange prefetches to avoid unnecessary prefetches at the end of an inner loop and to prefetch the first few iterations of the inner loop inside the next outer loop.
- Minimize the number of software prefetches. Prefetch instructions are not completely free in terms of bus cycles, machine cycles and resources; excessive usage of prefetches can adversely impact application performance.
- Interleave prefetches with computation instructions. For best performance, software prefetch instructions must be interspersed with computational instructions in the instruction sequence (rather than clustered together).

9.2 PREFETCH AND CACHEABILITY INSTRUCTIONS

The PREFETCH instruction, inserted by the programmers or compilers, accesses a cache line prior to the data actually being needed. This hides the latency for data access in the time required to process data already resident in the cache.

Many algorithms can provide information in advance about the data that is to be required. In cases where memory accesses are in long, regular data patterns; the automatic hardware prefetcher should be favored over software prefetches.

The cacheability control instructions allow you to control data caching strategy in order to increase cache efficiency and minimize cache pollution.

Data reference patterns can be classified as follows:

- Temporal — Data will be used again soon.
- Spatial — Data will be used in adjacent locations (for example, on the same cache line).
- Non-temporal — Data which is referenced once and not reused in the immediate future (for example, for some multimedia data types, as the vertex buffer in a 3D graphics application).

These data characteristics are used in the discussions that follow.

9.3 PREFETCH

This section discusses the mechanics of the software PREFETCH instructions. In general, software prefetch instructions should be used to supplement the practice of tuning an access pattern to suit the automatic hardware prefetch mechanism.

9.3.1 Software Data Prefetch

The PREFETCH instruction can hide the latency of data access in performance-critical sections of application code by allowing data to be fetched in advance of actual usage. PREFETCH instructions do not

change the user-visible semantics of a program, although they may impact program performance. PREFETCH merely provides a hint to the hardware and generally does not generate exceptions or faults.

PREFETCH loads either non-temporal data or temporal data in the specified cache level. This data access type and the cache level are specified as a hint. Depending on the implementation, the instruction fetches 32 or more aligned bytes (including the specified address byte) into the instruction-specified cache levels.

PREFETCH is implementation-specific; applications need to be tuned to each implementation to maximize performance.

NOTE

Using the PREFETCH instruction is recommended only if data does not fit in cache. Use of software prefetch should be limited to memory addresses that are managed or owned within the application context. Prefetching to addresses that are not mapped to physical pages can experience non-deterministic performance penalty. For example specifying a NULL pointer (0L) as address for a prefetch can cause long delays.

PREFETCH provides a hint to the hardware; it does not generate exceptions or faults except for a few special cases (see Section 9.3.3, “Prefetch and Load Instructions”). However, excessive use of PREFETCH instructions may waste memory bandwidth and result in a performance penalty due to resource constraints.

Nevertheless, PREFETCH can lessen the overhead of memory transactions by preventing cache pollution and by using caches and memory efficiently. This is particularly important for applications that share critical system resources, such as the memory bus. See an example in Section 9.6.2.1, “Video Encoder.”

PREFETCH is mainly designed to improve application performance by hiding memory latency in the background. If segments of an application access data in a predictable manner (for example, using arrays with known strides), they are good candidates for using PREFETCH to improve performance.

Use the PREFETCH instructions in:

- Predictable memory access patterns.
- Time-consuming innermost loops.
- Locations where the execution pipeline may stall if data is not available.

9.3.2 Prefetch Instructions

Streaming SIMD Extensions include four PREFETCH instruction variants; one non-temporal and three temporal. They correspond to two types of operations, temporal and non-temporal.

Additionally, the PREFETCHW instruction is a hint to fetch data closer to the processor and invalidates any other cached copy in anticipation of a write.

Software prefetch instructions will fetch a 64 byte line of data from memory that contains the byte specified with the source operand. Software prefetch instructions always fetch 64 bytes of data, and because the instructions operate on bytes, can never be split across cache-lines. Thus, a single software prefetch cannot be used to fetch 128 bytes of data.

NOTE

At the time of PREFETCH, if data is already found in a cache level that is closer to the processor than the cache level specified by the instruction, no data movement occurs.

The implementation details of the prefetch hint instructions vary across different microarchitectures. A summary is given in the table below.

Table 9-1. Implementation Details of Prefetch Hint Instructions

Intel Core Duo processors, Intel Core 2 processors, Intel Atom processors				
Instruction	Fill Cache?			
	L1	L2		
PrefetchT0	Yes	Yes		
PrefetchT1	No	Yes		
PrefetchT2	No	Yes		
PrefetchNTA	Yes	No		
PrefetchW ¹	Yes	Yes		
Processors based on Nehalem/Westmere/Sandy Bridge/Ivy Bridge/Haswell/Broadwell/Skylake microarchitecture				
Instruction	Fill Cache?			
	L1	L2	L3	
PrefetchT0	Yes	Yes	Yes	
PrefetchT1 ²	No	Yes	Yes	
PrefetchT2 ²	No	Yes	Yes	
PrefetchNTA	Yes	No	Yes ³	
PrefetchW ⁴	Yes	Yes	Yes	
Intel Xeon Scalable Family (non-inclusive L3)				
Instruction	Fill Cache?			Fill Snoop Filter?
	L1	L2	L3	
PrefetchT0	Yes	Yes	No	Yes
PrefetchT1	No	Yes	No	Yes
PrefetchT2	No	Yes	No	Yes
PrefetchNTA	Yes	No	No	Yes ³
PrefetchW ⁴	Yes	Yes	No	Yes

NOTES:

1. PrefetchW is only available on Intel Atom processors; not Intel Core duo or Intel Core 2 processors.
2. There is no implementation difference between PrefetchT1/T2 on any microarchitecture.
3. For PrefetchNTA, the fill into the L3 cache or Snoop Filter may not be placed into the Most Recently Used positioned and may be chosen for replacement faster than a regular cache fill.
4. PrefetchW is only available on processors based on Broadwell/Skylake microarchitecture; it is not available on processors based on Haswell microarchitecture or earlier microarchitectures.

9.3.3 Prefetch and Load Instructions

Most of the recent generations of microarchitectures have decoupled execution and memory pipelines. This allows instructions to be executed independently with memory accesses if there are no data and resource dependencies. Programs or compilers can use dummy load instructions to imitate PREFETCH functionality, but preloading is not completely equivalent to using PREFETCH instructions. PREFETCH provides greater performance than preloading.

PREFETCH can provide greater performance than preloading because:

- Has no destination register, it only updates cache lines.
- Does not stall the normal instruction retirement.
- Does not affect the functional behavior of the program.
- Has no cache line split accesses.
- Does not cause exceptions except when the LOCK prefix is used. The LOCK prefix is not a valid prefix for use with PREFETCH.
- Does not complete its own execution if that would cause a fault.

The advantages of PREFETCH over preloading instructions are processor specific. This may change in the future.

There are cases where a PREFETCH will not perform the data prefetch. These include:

- In older microarchitectures, PREFETCH causing a Data Translation Lookaside Buffer (DTLB) miss would be dropped. In processors based on Nehalem, Westmere, Sandy Bridge, and newer microarchitectures, Intel Core 2 processors, and Intel Atom processors, PREFETCH causing a DTLB miss can be fetched across a page boundary.
- An access to the specified address that causes a fault/exception.
- If the memory subsystem runs out of request buffers between the first-level cache and the second-level cache.
- PREFETCH targets an uncacheable memory region (for example, USWC and UC).
- The LOCK prefix is used. This causes an invalid opcode exception.

9.4 CACHEABILITY CONTROL

This section covers the mechanics of cacheability control instructions.

9.4.1 The Non-temporal Store Instructions

This section describes the behavior of streaming stores and reiterates some of the information presented in the previous section.

In Streaming SIMD Extensions, the MOVNTPS, MOVNTPD, MOVNTQ, MOVNTDQ, MOVNTI, MASKMOVQ and MASKMOVDQU instructions are streaming, non-temporal stores. With regard to memory characteristics and ordering, they are similar to the Write-Combining (WC) memory type:

- Write combining — Successive writes to the same cache line are combined.
- Write collapsing — Successive writes to the same byte(s) result in only the last write being visible.
- Weakly ordered — No ordering is preserved between WC stores or between WC stores and other loads or stores.
- Uncacheable and not write-allocating — Stored data is written around the cache and will not generate a read-for-ownership bus request for the corresponding cache line.

9.4.1.1 Fencing

Because streaming stores are weakly ordered, a fencing operation is required to ensure that the stored data is flushed from the processor to memory. Failure to use an appropriate fence may result in data being “trapped” within the processor and will prevent visibility of this data by other processors or system agents.

WC stores require software to ensure coherence of data by performing the fencing operation. See Section 9.4.5, “FENCE Instructions.”

9.4.1.2 Streaming Non-temporal Stores

Streaming stores can improve performance by:

- Increasing store bandwidth if the 64 bytes that fit within a cache line are written consecutively (since they do not require read-for-ownership bus requests and 64 bytes are combined into a single bus write transaction).
- Reducing disturbance of frequently used cached (temporal) data (since they write around the processor caches).

Streaming stores allow cross-aliasing of memory types for a given memory region. For instance, a region may be mapped as write-back (WB) using page attribute tables (PAT) or memory type range registers (MTRRs) and yet is written using a streaming store.

9.4.1.3 Memory Type and Non-temporal Stores

Memory type can take precedence over a non-temporal hint, leading to the following considerations:

- If the programmer specifies a non-temporal store to strongly-ordered uncacheable memory (for example, Uncacheable (UC) or Write-Protect (WP) memory types), then the store behaves like an uncacheable store. The non-temporal hint is ignored and the memory type for the region is retained.
- If the programmer specifies the weakly-ordered uncacheable memory type of Write-Combining (WC), then the non-temporal store and the region have the same semantics and there is no conflict.
- If the programmer specifies a non-temporal store to cacheable memory (for example, Write-Back (WB) or Write-Through (WT) memory types), two cases may result:
 - CASE 1 — If the data is present in the cache hierarchy, the instruction will ensure consistency. A particular processor may choose different ways to implement this. The following approaches are probable: (a) updating data in-place in the cache hierarchy while preserving the memory type semantics assigned to that region or (b) evicting the data from the caches and writing the new non-temporal data to memory (with WC semantics).

The approaches (separate or combined) can be different for different processors.

If the streaming store hits a line that is present in the first-level cache, the store data is combined in place within the first-level cache. If the streaming store hits a line present in the second-level, the line and stored data is flushed from the second-level to system memory.

- CASE 2 — If the data is not present in the cache hierarchy and the destination region is mapped as WB or WT; the transaction will be weakly ordered and is subject to all WC memory semantics. This non-temporal store will not write-allocate. Different implementations may choose to collapse and combine such stores.

9.4.1.4 Write-Combining

Generally, WC semantics require software to ensure coherence with respect to other processors and other system agents (such as graphics cards). Appropriate use of synchronization and a fencing operation must be performed for producer-consumer usage models (see Section 9.4.5, "FENCE Instructions"). Fencing ensures that all system agents have global visibility of the stored data. For instance, failure to fence may result in a written cache line staying within a processor, and the line would not be visible to other agents.

For processors which implement non-temporal stores by updating data in-place that already resides in the cache hierarchy, the destination region should also be mapped as WC. Otherwise, if mapped as WB or WT, there is a potential for speculative processor reads to bring the data into the caches. In such a case, non-temporal stores would then update in place and data would not be flushed from the processor by a subsequent fencing operation.

The memory type visible on the bus in the presence of memory type aliasing is implementation-specific. As one example, the memory type written to the bus may reflect the memory type for the first store to

the line, as seen in program order. Other alternatives are possible. This behavior should be considered reserved and dependence on the behavior of any particular implementation risks future incompatibility.

9.4.2 Streaming Store Usage Models

The two primary usage domains for streaming store are coherent requests and non-coherent requests.

9.4.2.1 Coherent Requests

Coherent requests are normal loads and stores to system memory, which may also hit cache lines present in another processor in a multiprocessor environment. With coherent requests, a streaming store can be used in the same way as a regular store that has been mapped with a WC memory type (PAT or MTRR). An SFENCE instruction must be used within a producer-consumer usage model in order to ensure coherency and visibility of data between processors.

Within a single-processor system, the CPU can also re-read the same memory location and be assured of coherence (that is, a single, consistent view of this memory location). The same is true for a multiprocessor (MP) system, assuming an accepted MP software producer-consumer synchronization policy is employed.

9.4.2.2 Non-coherent requests

Non-coherent requests arise from an I/O device, such as an AGP graphics card, that reads or writes system memory using non-coherent requests, which are not reflected on the processor bus and thus will not query the processor's caches. An SFENCE instruction must be used within a producer-consumer usage model in order to ensure coherency and visibility of data between processors. In this case, if the processor is writing data to the I/O device, a streaming store can be used with a processor with any behavior of Case 1 (Section 9.4.1.3) only if the region has also been mapped with a WC memory type (PAT, MTRR).

NOTE

Failure to map the region as WC may allow the line to be speculatively read into the processor caches (via the wrong path of a mispredicted branch).

In case the region is not mapped as WC, the streaming might update in-place in the cache and a subsequent SFENCE would not result in the data being written to system memory. Explicitly mapping the region as WC in this case ensures that any data read from this region will not be placed in the processor's caches. A read of this memory location by a non-coherent I/O device would return incorrect/out-of-date results.

For a processor which solely implements Case 2 (Section 9.4.1.3), a streaming store can be used in this non-coherent domain without requiring the memory region to also be mapped as WB, since any cached data will be flushed to memory by the streaming store.

9.4.3 Streaming Store Instruction Descriptions

MOVNTQ/MOVNTDQ (non-temporal store of packed integer in an MMX technology or Streaming SIMD Extensions register) store data from a register to memory. They are implicitly weakly-ordered, do no write-allocate, and so minimize cache pollution.

MOVNTPS (non-temporal store of packed single precision floating-point) is similar to MOVNTQ. It stores data from a Streaming SIMD Extensions register to memory in 16-byte granularity. Unlike MOVNTQ, the memory address must be aligned to a 16-byte boundary or a general protection exception will occur. The instruction is implicitly weakly-ordered, does not write-allocate, and thus minimizes cache pollution.

MASKMOVQ/MASKMOVDQU (non-temporal byte mask store of packed integer in an MMX technology or Streaming SIMD Extensions register) store data from a register to the location specified by the EDI register. The most significant bit in each byte of the second mask register is used to selectively write the

data of the first register on a per-byte basis. The instructions are implicitly weakly-ordered (that is, successive stores may not write memory in original program-order), do not write-allocate, and thus minimize cache pollution.

9.4.4 The Streaming Load Instruction

SSE4.1 introduces the MOVNTDQA instruction. MOVNTDQA loads 16 bytes from memory using a non-temporal hint if the memory source is WC type. For WC memory type, the non-temporal hint may be implemented by loading into a temporary internal buffer with the equivalent of an aligned cache line without filling this data to the cache. Subsequent MOVNTDQA reads to unread portions of the buffered WC data will cause 16 bytes of data transferred from the temporary internal buffer to an XMM register if data is available.

If used appropriately, MOVNTDQA can help software achieve significantly higher throughput when loading data in WC memory region into the processor than other means.

Chapter 1 provides a reference to an application note on using MOVNTDQA. Additional information and requirements to use MOVNTDQA appropriately can be found in Chapter 12, "Programming with Intel® SSE3, SSSE3, Intel® SSE4 AND Intel® AESNI" of *Intel® 64 and IA-32 Architectures Software Developer's Manual, Volume 1*, and the instruction reference pages of MOVNTDQA in *Intel® 64 and IA-32 Architectures Software Developer's Manual, Volume 2A*.

9.4.5 FENCE Instructions

The following fence instructions are available: SFENCE, IFENCE, and MFENCE.

9.4.5.1 SFENCE Instruction

The SFENCE (STORE FENCE) instruction makes it possible for every STORE instruction that precedes an SFENCE in program order to be globally visible before any STORE that follows the SFENCE. SFENCE provides an efficient way of ensuring ordering between routines that produce weakly-ordered results.

The use of weakly-ordered memory types can be important under certain data sharing relationships (such as a producer-consumer relationship). Using weakly-ordered memory can make assembling the data more efficient, but care must be taken to ensure that the consumer obtains the data that the producer intended to see.

Some common usage models may be affected by weakly-ordered stores. Examples are:

- Library functions, which use weakly-ordered memory to write results.
- Compiler-generated code, which also benefits from writing weakly-ordered results.
- Hand-crafted code.

The degree to which a consumer of data knows that the data is weakly-ordered can vary for different cases. As a result, SFENCE should be used to ensure ordering between routines that produce weakly-ordered data and routines that consume this data.

9.4.5.2 LFENCE Instruction

The LFENCE (LOAD FENCE) instruction makes it possible for every LOAD instruction that precedes the LFENCE instruction in program order to be globally visible before any LOAD instruction that follows the LFENCE.

The LFENCE instruction provides a means of segregating LOAD instructions from other LOADs.

9.4.5.3 MFENCE Instruction

The MFENCE (MEMORY FENCE) instruction makes it possible for every LOAD/STORE instruction preceding MFENCE in program order to be globally visible before any LOAD/STORE following MFENCE. MFENCE provides a means of segregating certain memory instructions from other memory references.

The use of a LFENCE and SFENCE is not equivalent to the use of a MFENCE since the load and store fences are not ordered with respect to each other. In other words, the load fence can be executed before prior stores and the store fence can be executed before prior loads.

MFENCE should be used whenever the cache line flush instruction (CLFLUSH) is used to ensure that speculative memory references generated by the processor do not interfere with the flush. See Section 9.4.6, “CLFLUSH Instruction.”

9.4.6 CLFLUSH Instruction

The CLFLUSH instruction invalidates the cache line associated with the linear address that contain the byte address of the memory location, from all levels of the processor cache hierarchy (data and instruction). This invalidation is broadcast throughout the coherence domain. If, at any level of the cache hierarchy, a line is inconsistent with memory (dirty), it is written to memory before invalidation. Other characteristics include:

- The data size affected is the cache coherency size, which is enumerated by the CPUID instruction. It is typically 64 bytes.
- The memory attribute of the page containing the affected line has no effect on the behavior of this instruction.
- The CLFLUSH instruction can be used at all privilege levels and is subject to all permission checking and faults associated with a byte load.

Executions of the CLFLUSH instruction are ordered with respect to each other and with respect to writes, locked read-modify-write instructions, fence instructions, and executions of CLFLUSHOPT to the same cache line¹. They are not ordered with respect to executions of CLFLUSHOPT to different cache lines. For updated memory order details of CLFLUSH and other memory traffic, please refer to the CLFLUSH reference pages in Chapter 3 of *Intel® 64 and IA-32 Architectures Software Developer’s Manual, Volume 2A*, and the “Memory Ordering” section in Chapter 9 of *Intel® 64 and IA-32 Architectures Software Developer’s Manual, Volume 3A*.

As an example, consider a video usage model where a video capture device is using non-coherent accesses to write a capture stream directly to system memory. Since these non-coherent writes are not broadcast on the processor bus, they will not flush copies of the same locations that reside in the processor caches. As a result, before the processor re-reads the capture buffer, it should use CLFLUSH to ensure that stale, cached copies of the capture buffer are flushed from the processor caches.

Example 9-1 provides pseudo-code for CLFLUSH usage.

Example 9-1. Pseudo-code Using CLFLUSH

```
while (!buffer_ready) {}
sfence
for(i=0;i<num_cachelines;i+=cacheline_size) {
    cflush (char *)((unsigned int)buffer + i)
}
prefnta buffer[0];
VAR = buffer[0];
```

1. Memory order recommendation of CLFLUSH in previous manuals had required software to add MFENCE after CLFLUSH. MFENCE is not required following CLFLUSH as all processors implementing the CLFLUSH instruction also order it relative to the other operations enumerated above.

The throughput characteristics of using CLFLUSH to flush cache lines can vary significantly depending on several factors. In general using CLFLUSH back-to-back to flush a large number of cache lines will experience larger cost per cache line than flushing a moderately-sized buffer (e.g. less than 4KB); the reduction of CLFLUSH throughput can be an order of magnitude. Flushing cache lines in modified state are more costly than flushing cache lines in non-modified states.

9.4.7 CLFLUSHOPT Instruction

The CLFLUSHOPT instruction is first introduced in the 6th Generation Intel Core Processors. Similar to CLFLUSH, CLFLUSHOPT invalidates the cache line associated with the linear address that contain the byte address of the memory location, in all levels of the processor cache hierarchy (data and instruction).

Executions of the CLFLUSHOPT instruction are ordered with respect to locked read-modify-write instructions, fence instructions, and writes to the cache line being invalidated. (They are also ordered with respect to executions of CLFLUSH and CLFLUSHOPT to the same cache line.) They are not ordered with respect to writes to cache lines other than the one being invalidated. (They are also not ordered with respect to executions of CLFLUSH and CLFLUSHOPT to different cache lines.) Software can insert an SFENCE instruction between CLFLUSHOPT and a store to another cache line with which the CLFLUSHOPT should be ordered.

In general, CLFLUSHOPT throughput is higher than that of CLFLUSH, because CLFLUSHOPT orders itself with respect to a smaller set of memory traffic as described above and in Section 9.4.6. The throughput of CLFLUSHOPT will also vary. When using CLFLUSHOPT, flushing modified cache lines will experience a higher cost than flushing cache lines in non-modified states. CLFLUSHOPT will provide a performance benefit over CLFLUSH for cache lines in any coherence states. CLFLUSHOPT is more suitable to flush large buffers (e.g. greater than many KBytes), compared to CLFLUSH. In single-threaded applications, flushing buffers using CLFLUSHOPT may be up to 9X better than using CLFLUSH with Skylake microarchitecture.

Figure 9-1 shows the comparison of the performance characteristics of executing CLFLUSHOPT versus CLFLUSH for buffers of various sizes.

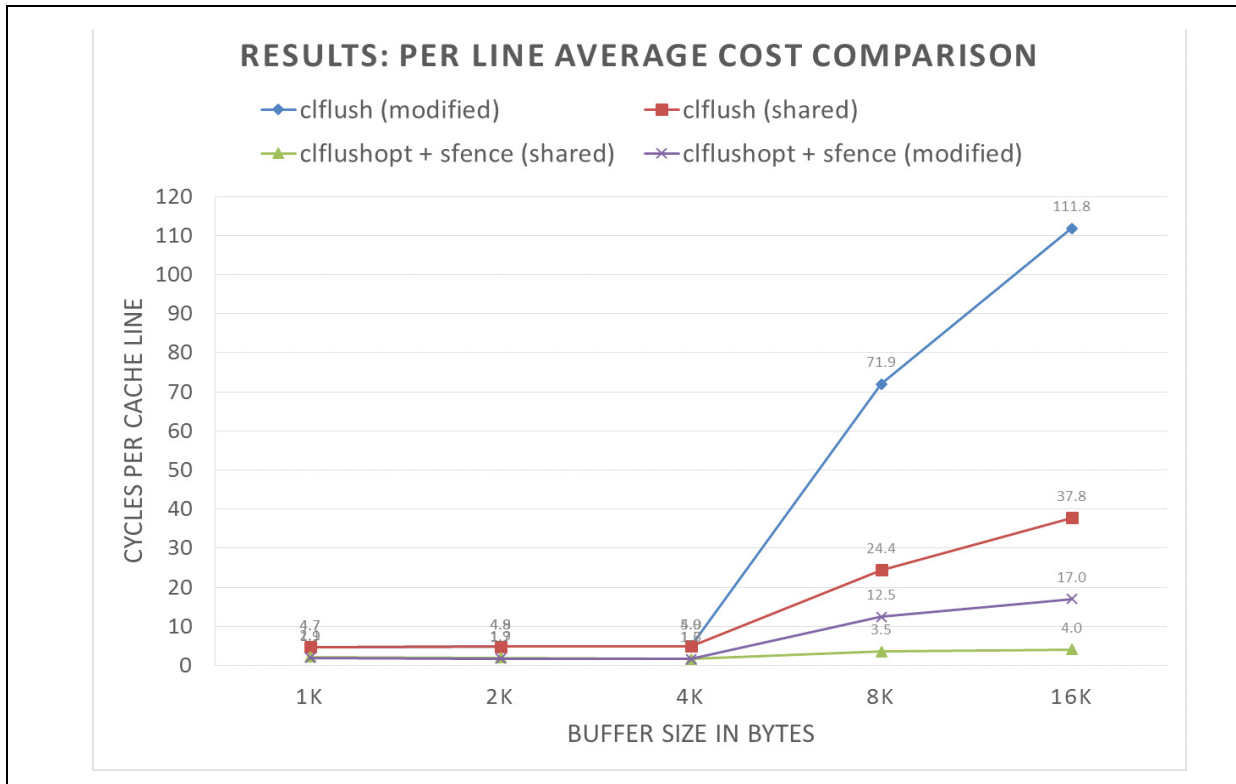

Figure 9-1. CLFLUSHOPT versus CLFLUSH In SkyLake Microarchitecture

User/Source Coding Rule 13. If CLFLUSHOPT is available, use CLFLUSHOPT over CLFLUSH and use SFENCE to guard CLFLUSHOPT to ensure write order is globally observed. If CLFLUSHOPT is not available, consider flushing large buffers with CLFLUSH in smaller chunks of less than 4KB.

Example 9-2 gives equivalent assembly sequences of flushing cache lines using CLFLUSH or CLFLUSHOPT. The corresponding sequence in C are:

CLFLUSH:

```
For (i = 0; i < iSizeOfBufferToFlush; i += CACHE_LINE_SIZE) _mm_clflush( &pBufferToFlush[ i ] );
```

CLFLUSHOPT:

```
_mm_sfence();
```

```
For (i = 0; i < iSizeOfBufferToFlush; i += CACHE_LINE_SIZE) _mm_clflushopt( &pBufferToFlush[ i ] );
```

```
_mm_sfence();
```

Example 9-2. Flushing Cache Lines Using CLFLUSH or CLFLUSHOPT

CLFLUSH no longer requires mfence	CLFLUSHOPT w/ SFENCE
<pre>xor rcx, rcx mov r9, pBufferToFlush mov rsi, iSizeOfBufferToFlush ;; mfence - obsolete loop: clflush [r9+rcx] add rcx, 0x40 cmp rcx, rsi jl loop ;; mfence - obsolete</pre>	<pre>xor rcx, rcx mov r9, pBufferToFlush mov rsi, iSizeOfBufferToFlush sfence loop: clflushopt [r9+rcx] add rcx, 0x40 cmp rcx, rsi jl loop sfence</pre>
<p>* If imposing memory ordering rules is important for the application then executing CLFLUSHOPT instructions should be guarded with SFENCE instructions to guarantee order of memory writes. As per the figure above, such solution still performs better than using the CLFLUSH instruction, and its performance is identical to CLFLUSHOPT from 2048 byte buffers and bigger.</p>	

9.5 MEMORY OPTIMIZATION USING PREFETCH

Recent generations of Intel processors have two mechanisms for data prefetch: software-controlled prefetch and an automatic hardware prefetch.

9.5.1 Software-Controlled Prefetch

The software-controlled prefetch is enabled using the four PREFETCH instructions introduced with Streaming SIMD Extensions instructions. These instructions are hints to bring a cache line of data in to various levels and modes in the cache hierarchy. The software-controlled prefetch is not intended for prefetching code. Using it can incur significant penalties on a multiprocessor system when code is shared.

Software prefetching has the following characteristics:

- Can handle irregular access patterns which do not trigger the hardware prefetcher.
- Can use less bus bandwidth than hardware prefetching; see below.
- Software prefetches must be added to new code, and do not benefit existing applications.

9.5.2 Hardware Prefetch

Automatic hardware prefetch can bring cache lines into the unified last-level cache based on prior data misses. It will attempt to prefetch two cache lines ahead of the prefetch stream. Characteristics of the hardware prefetcher are:

- It requires some regularity in the data access patterns.
 - If a data access pattern has constant stride, hardware prefetching is effective if the access stride is less than half of the trigger distance of hardware prefetcher.
 - If the access stride is not constant, the automatic hardware prefetcher can mask memory latency if the strides of two successive cache misses are less than the trigger threshold distance (small-stride memory traffic).
 - The automatic hardware prefetcher is most effective if the strides of two successive cache misses remain less than the trigger threshold distance and close to 64 bytes.

- There is a start-up penalty before the prefetcher triggers and there may be fetches an array finishes. For short arrays, overhead can reduce effectiveness.
 - The hardware prefetcher requires a couple misses before it starts operating.
 - Hardware prefetching generates a request for data beyond the end of an array, which is not be utilized. This behavior wastes bus bandwidth. In addition this behavior results in a start-up penalty when fetching the beginning of the next array. Software prefetching may recognize and handle these cases.
- It will not prefetch across a 4-KByte page boundary. A program has to initiate demand loads for the new page before the hardware prefetcher starts prefetching from the new page.
- The hardware prefetcher may consume extra system bandwidth if the application's memory traffic has significant portions with strides of cache misses greater than the trigger distance threshold of hardware prefetch (large-stride memory traffic).
- The effectiveness with existing applications depends on the proportions of small-stride versus large-stride accesses in the application's memory traffic. An application with a preponderance of small-stride memory traffic with good temporal locality will benefit greatly from the automatic hardware prefetcher.
- In some situations, memory traffic consisting of a preponderance of large-stride cache misses can be transformed by re-arrangement of data access sequences to alter the concentration of small-stride cache misses at the expense of large-stride cache misses to take advantage of the automatic hardware prefetcher.

9.5.3 Example of Effective Latency Reduction with Hardware Prefetch

Consider the situation that an array is populated with data corresponding to a constant-access-stride, circular pointer chasing sequence (see Example 9-3). The potential of employing the automatic hardware prefetching mechanism to reduce the effective latency of fetching a cache line from memory can be illustrated by varying the access stride between 64 bytes and the trigger threshold distance of hardware prefetch when populating the array for circular pointer chasing.

Example 9-3. Populating an Array for Circular Pointer Chasing with Constant Stride

```

register char ** p;
char *next;    // Populating pArray for circular pointer
               // chasing with constant access stride
               // p = (char **) *p; loads a value pointing to next load
p = (char **)&pArray;

for (i = 0; i < aperture; i += stride) {
    p = (char **)&pArray[i];
    if (i + stride >= g_array_aperture) {
        next = &pArray[0];
    }
    else {
        next = &pArray[i + stride];
    }
    *p = next; // populate the address of the next node
}

```

The effective latency reduction for several microarchitecture implementations is shown in Figure 9-2. For a constant-stride access pattern, the benefit of the automatic hardware prefetcher begins at half the trigger threshold distance and reaches maximum benefit when the cache-miss stride is 64 bytes.

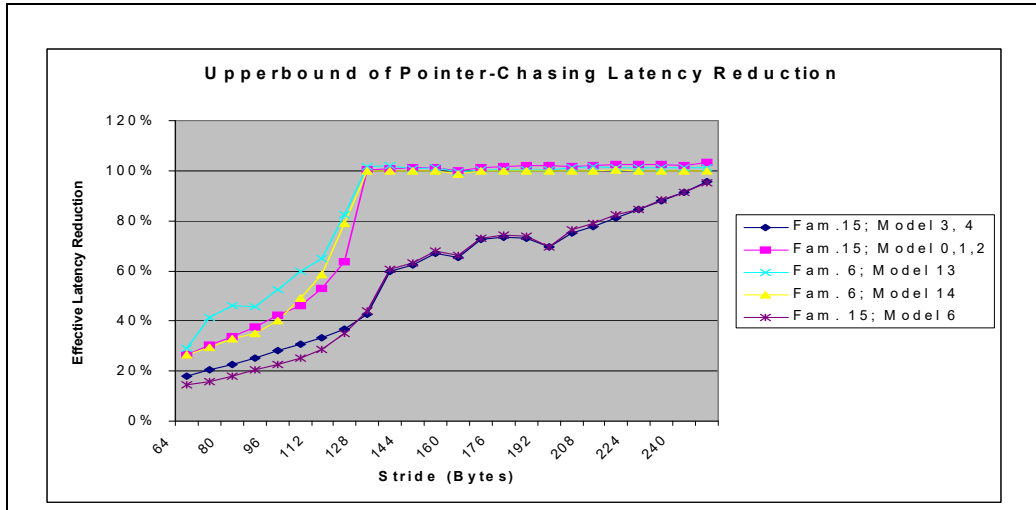

Figure 9-2. Effective Latency Reduction as a Function of Access Stride

9.5.4 Example of Latency Hiding with S/W Prefetch Instruction

Achieving the highest level of memory optimization using PREFETCH instructions requires an understanding of the architecture of a given machine. This section translates the key architectural implications into several simple guidelines for programmers to use.

Figure 9-3 and Figure 9-4 show two scenarios of a simplified 3D geometry pipeline as an example. A 3D-geometry pipeline typically fetches one vertex record at a time and then performs transformation and lighting functions on it. Both figures show two separate pipelines, an execution pipeline, and a memory pipeline (front-side bus).

Since the processor completely decouples the functionality of execution and memory access, the two pipelines can function concurrently. Figure 9-3 shows “bubbles” in both the execution and memory pipelines. When loads are issued for accessing vertex data, the execution units sit idle and wait until data is returned. On the other hand, the memory bus sits idle while the execution units are processing vertices. This scenario severely decreases the advantage of having a decoupled architecture.

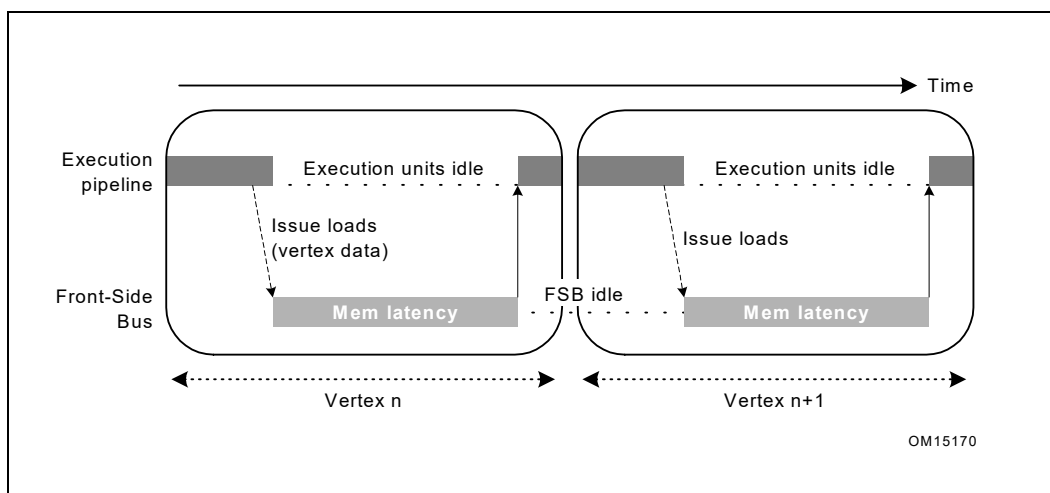

Figure 9-3. Memory Access Latency and Execution Without Prefetch

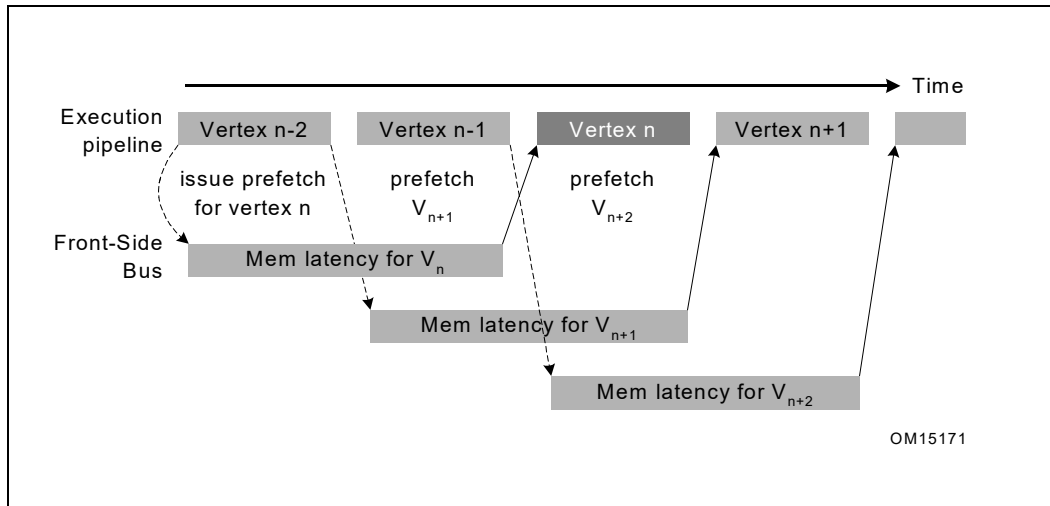

Figure 9-4. Memory Access Latency and Execution With Prefetch

The performance loss caused by poor utilization of resources can be completely eliminated by correctly scheduling the PREFETCH instructions. As shown in Figure 9-4, prefetch instructions are issued two vertex iterations ahead. This assumes that only one vertex gets processed in one iteration and a new data cache line is needed for each iteration. As a result, when iteration n , vertex V_n , is being processed; the requested data is already brought into cache. In the meantime, the front-side bus is transferring the data needed for iteration $n+1$, vertex V_{n+1} . Because there is no dependence between V_{n+1} data and the execution of V_n , the latency for data access of V_{n+1} can be entirely hidden behind the execution of V_n . Under such circumstances, no “bubbles” are present in the pipelines and thus the best possible performance can be achieved.

Prefetching is useful for inner loops that have heavy computations, or are close to the boundary between being compute-bound and memory-bandwidth-bound. It is probably not very useful for loops which are predominately memory bandwidth-bound.

When data is already located in the first level cache, prefetching can be useless and could even slow down the performance because the extra μ ops either back up waiting for outstanding memory accesses or may be dropped altogether. This behavior is platform-specific and may change in the future.

9.5.5 Software Prefetching Usage Checklist

The following checklist covers issues that need to be addressed and/or resolved to use the software PREFETCH instruction properly:

- Determine software prefetch scheduling distance.
- Use software prefetch concatenation.
- Minimize the number of software prefetches.
- Mix software prefetch with computation instructions.
- Use cache blocking techniques (for example, strip mining).
- Balance single-pass versus multi-pass execution.
- Resolve memory bank conflict issues.
- Resolve cache management issues.

Subsequent sections discuss the above items.

9.5.6 Software Prefetch Scheduling Distance

Determining the ideal prefetch placement in the code depends on many architectural parameters, including: the amount of memory to be prefetched, cache lookup latency, system memory latency, and estimate of computation cycle. The ideal distance for prefetching data is processor- and platform-dependent. If the distance is too short, the prefetch will not hide the latency of the fetch behind computation. If the prefetch is too far ahead, prefetched data may be flushed out of the cache by the time it is required.

Since prefetch distance is not a well-defined metric, for this discussion, we define a new term, prefetch scheduling distance (PSD), which is represented by the number of iterations. For large loops, prefetch scheduling distance can be set to 1 (that is, schedule prefetch instructions one iteration ahead). For small loop bodies (that is, loop iterations with little computation), the prefetch scheduling distance must be more than one iteration.

A simplified equation to compute PSD is deduced from the mathematical model.

Example 9-4 illustrates the use of a prefetch within the loop body. The prefetch scheduling distance is set to 3, ESI is effectively the pointer to a line, EDX is the address of the data being referenced and XMM1-XMM4 are the data used in computation. Example 9-5 uses two independent cache lines of data per iteration. The PSD would need to be increased/decreased if more/less than two cache lines are used per iteration.

Example 9-4. Prefetch Scheduling Distance

```

top_loop:
    prefetchnta [edx + esi + 128*3]
    prefetchnta [edx*4 + esi + 128*3]
    .....

    movaps xmm1, [edx + esi]
    movaps xmm2, [edx*4 + esi]
    movaps xmm3, [edx + esi + 16]
    movaps xmm4, [edx*4 + esi + 16]
    .....
    .....

    add    esi, 128
    cmp    esi, ecx
    jl     top_loop

```

9.5.7 Software Prefetch Concatenation

Maximum performance can be achieved when the execution pipeline is at maximum throughput, without incurring any memory latency penalties. This can be achieved by prefetching data to be used in successive iterations in a loop. De-pipelining memory generates bubbles in the execution pipeline.

To explain this performance issue, a 3D geometry pipeline that processes 3D vertices in strip format is used as an example. A strip contains a list of vertices whose predefined vertex order forms contiguous triangles. It can be easily observed that the memory pipe is de-pipelined on the strip boundary due to ineffective prefetch arrangement. The execution pipeline is stalled for the first two iterations for each strip. As a result, the average latency for completing an iteration will be 165 (FIX) clocks.

This memory de-pipelining creates inefficiency in both the memory pipeline and execution pipeline. This de-pipelining effect can be removed by applying a technique called prefetch concatenation. With this technique, the memory access and execution can be fully pipelined and fully utilized.

For nested loops, memory de-pipelining could occur during the interval between the last iteration of an inner loop and the next iteration of its associated outer loop. Without paying special attention to prefetch insertion, loads from the first iteration of an inner loop can miss the cache and stall the execution pipeline waiting for data returned, thus degrading the performance.

In Example 9-5, the cache line containing `A[II][0]` is not prefetched at all and always misses the cache. This assumes that no array `A[][]` footprint resides in the cache. The penalty of memory de-pipelining stalls can be amortized across the inner loop iterations. However, it may become very harmful when the inner loop is short. In addition, the last prefetch in the last PSD iterations are wasted and consume machine resources. Prefetch concatenation is introduced here in order to eliminate the performance issue of memory de-pipelining.

Example 9-5. Using Prefetch Concatenation

```
for (ii = 0; ii < 100; ii++) {
    for (jj = 0; jj < 32; jj+=8) {
        prefetch a[ii][jj+8]
        computation a[ii][jj]
    }
}
```

Prefetch concatenation can bridge the execution pipeline bubbles between the boundary of an inner loop and its associated outer loop. Simply by unrolling the last iteration out of the inner loop and specifying the effective prefetch address for data used in the following iteration, the performance loss of memory de-pipelining can be completely removed. Example 9-6 gives the rewritten code.

Example 9-6. Concatenation and Unrolling the Last Iteration of Inner Loop

```
for (ii = 0; ii < 100; ii++) {
    for (jj = 0; jj < 24; jj+=8) { /* N-1 iterations */
        prefetch a[ii][jj+8]
        computation a[ii][jj]
    }
    prefetch a[ii+1][0]
    computation a[ii][24] /* Last iteration */
}
```

This code segment for data prefetching is improved and only the first iteration of the outer loop suffers any memory access latency penalty, assuming the computation time is larger than the memory latency. Inserting a prefetch of the first data element needed prior to entering the nested loop computation would eliminate or reduce the start-up penalty for the very first iteration of the outer loop. This uncomplicated high-level code optimization can improve memory performance significantly.

9.5.8 Minimize Number of Software Prefetches

Prefetch instructions are not completely free in terms of bus cycles, machine cycles and resources, even though they require minimal clock and memory bandwidth.

Excessive prefetching may lead to performance penalties because of issue penalties in the front end of the machine and/or resource contention in the memory sub-system. This effect may be severe in cases where the target loops are small and/or cases where the target loop is issue-bound.

One approach to solve the excessive prefetching issue is to unroll and/or software-pipeline loops to reduce the number of prefetches required. Figure 9-5 presents a code example which implements prefetch and unrolls the loop to remove the redundant prefetch instructions whose prefetch addresses hit the previously issued prefetch instructions. In this particular example, unrolling the original loop once saves six prefetch instructions and nine instructions for conditional jumps in every other iteration.

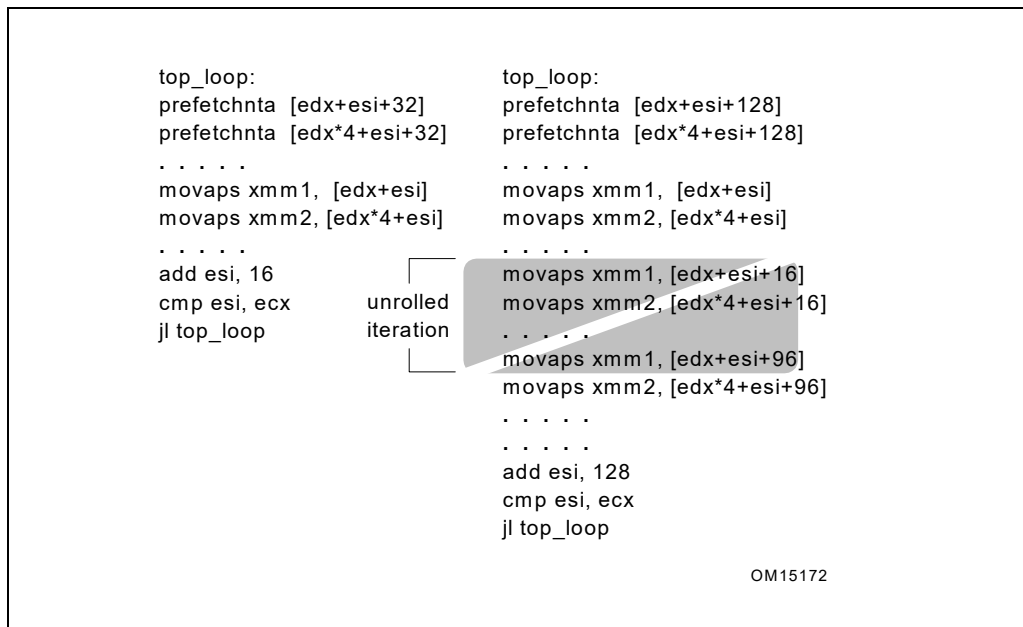

Figure 9-5. Prefetch and Loop Unrolling

Figure 9-6 demonstrates the effectiveness of software prefetches in latency hiding.

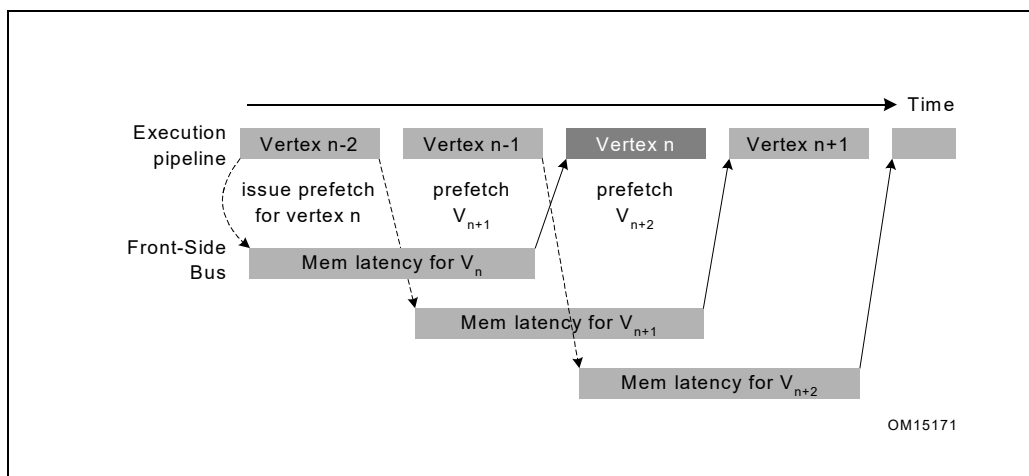

Figure 9-6. Memory Access Latency and Execution With Prefetch

The X axis in Figure 9-6 indicates the number of computation clocks per loop (each iteration is independent). The Y axis indicates the execution time measured in clocks per loop. The secondary Y axis indicates the percentage of bus bandwidth utilization. The tests vary by the following parameters:

- Number of load/store streams — Each load and store stream accesses one 128-byte cache line each per iteration.
- Amount of computation per loop — This is varied by increasing the number of dependent arithmetic operations executed.
- Number of the software prefetches per loop — For example, one every 16 bytes, 32 bytes, 64 bytes, 128 bytes.

As expected, the leftmost portion of each of the graphs in Figure 9-6 shows that when there is not enough computation to overlap the latency of memory access, prefetch does not help and that the execution is essentially memory-bound. The graphs also illustrate that redundant prefetches do not increase performance.

9.5.9 Mix Software Prefetch with Computation Instructions

It may seem convenient to cluster all of PREFETCH instructions at the beginning of a loop body or before a loop, but this can lead to severe performance degradation. In order to achieve the best possible performance, PREFETCH instructions must be interspersed with other computational instructions in the instruction sequence rather than clustered together. If possible, they should also be placed apart from loads. This improves the instruction level parallelism and reduces the potential instruction resource stalls. In addition, this mixing reduces the pressure on the memory access resources and in turn reduces the possibility of the prefetch retiring without fetching data.

Figure 9-7 illustrates distributing PREFETCH instructions. Rearranging PREFETCH instructions could yield a noticeable speedup for the code which stresses the cache resource.

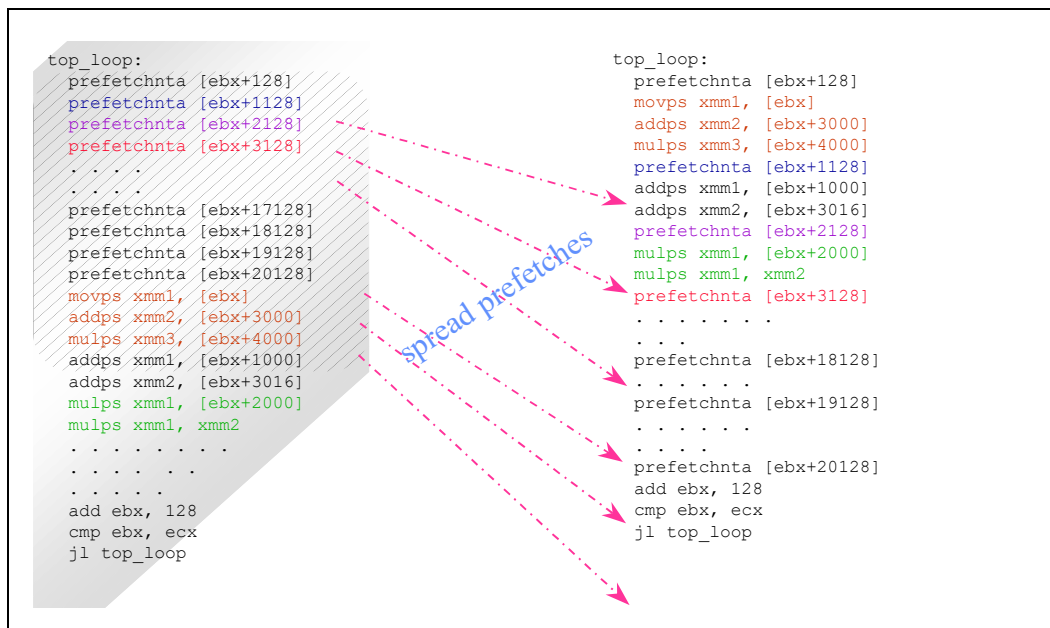

Figure 9-7. Spread Prefetch Instructions

NOTE

To avoid instruction execution stalls due to the over-utilization of the resource, PREFETCH instructions must be interspersed with computational instructions. The spreading of PREFETCH instructions may need to be retuned for new processors.

9.5.10 Software Prefetch and Cache Blocking Techniques

Cache blocking techniques (such as strip-mining) are used to improve temporal locality and the cache hit rate. Strip-mining is one-dimensional temporal locality optimization for memory. When higher-dimensional arrays are used in programs, loop blocking technique (similar to strip-mining but in two dimensions) can be applied for a better memory performance.

If an application uses a large data set that can be reused across multiple passes of a loop, it will benefit from strip mining. Data sets larger than the cache will be processed in groups small enough to fit into cache. This allows temporal data to reside in the cache longer, reducing bus traffic.

Data set size and temporal locality (data characteristics) fundamentally affect how PREFETCH instructions are applied to strip-mined code. Figure 9-8 shows two simplified scenarios for temporally-adjacent data and temporally-non-adjacent data.

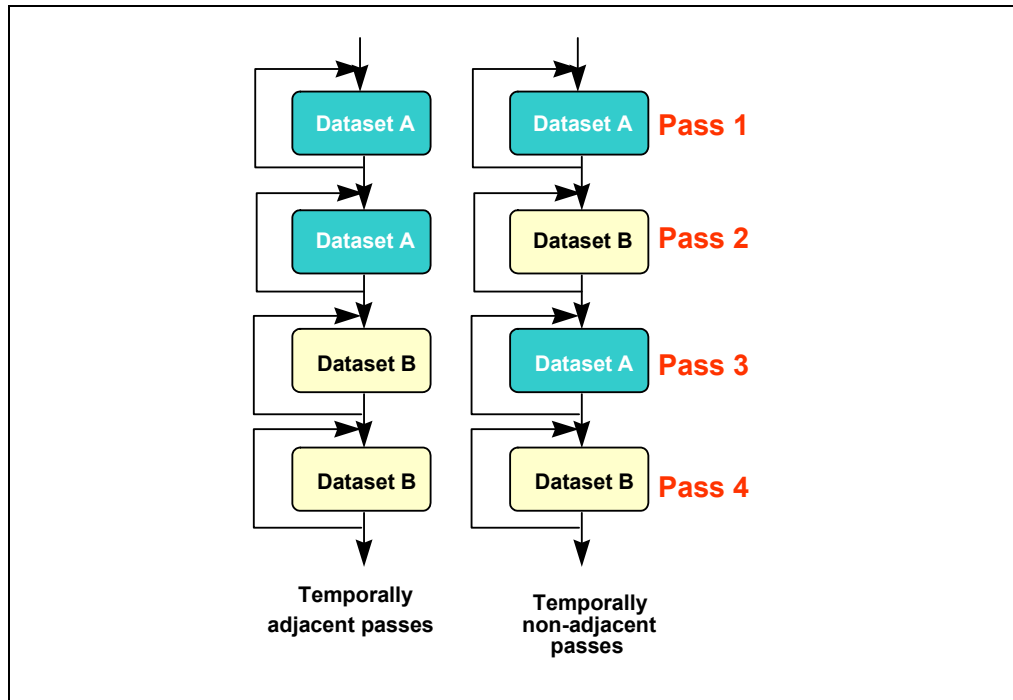

Figure 9-8. Cache Blocking - Temporally Adjacent and Non-adjacent Passes

In the temporally-adjacent scenario, subsequent passes use the same data and find it already in second-level cache. Prefetch issues aside, this is the preferred situation. In the temporally non-adjacent scenario, data used in pass m is displaced by pass $(m+1)$, requiring data *re-fetch* into the first level cache and perhaps the second level cache if a later pass reuses the data. If both data sets fit into the second-level cache, load operations in passes 3 and 4 become less expensive.

Figure 9-9 shows how prefetch instructions and strip-mining can be applied to increase performance in both of these scenarios.

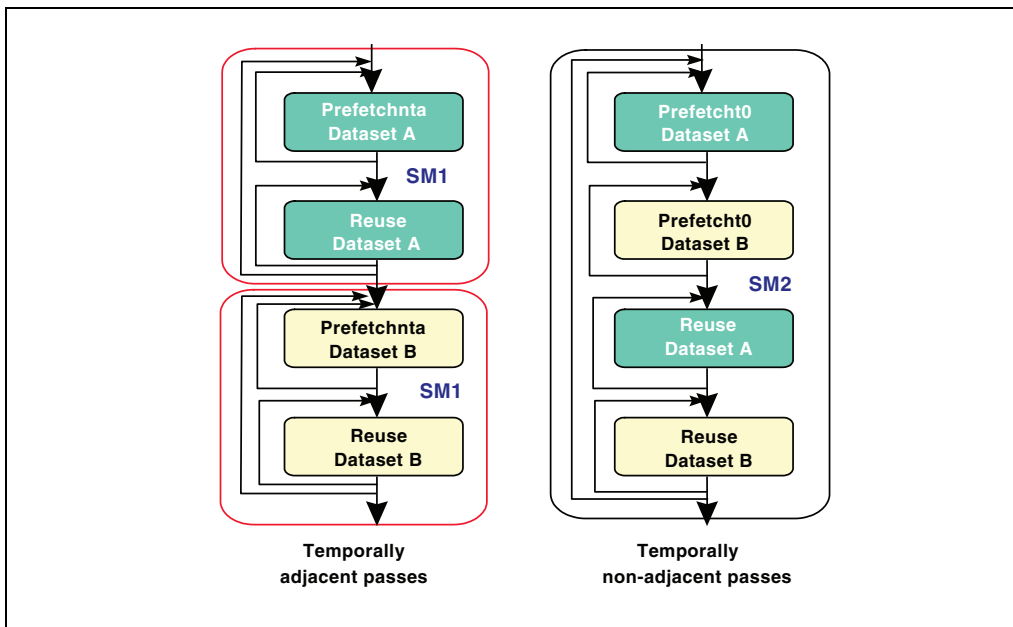

Figure 9-9. Examples of Prefetch and Strip-mining for Temporally Adjacent and Non-Adjacent Passes Loops

The left scenario shows a graphical implementation of using PREFETCHNTA to prefetch data into L1, minimizing second-level cache pollution. Use PREFETCHNTA if the data is only touched once during the entire execution pass in order to minimize cache pollution in the higher level caches. This provides instant availability, assuming the prefetch was issued far ahead enough, when the read access is issued.

In the scenario to the right (see Figure 9-9), the workload footprint is too large for the L1 cache. Therefore, use PREFETCHT0 to prefetch the data. This amortizes the latency of the memory references in passes 1 and 2, and keeps a copy of the data in second-level cache, which reduces memory traffic and latencies for passes 3 and 4. To further reduce the latency, it might be worth considering extra PREFETCHNTA instructions prior to the memory references in passes 3 and 4.

In Example 9-7, consider the data access patterns of a 3D geometry engine first without strip-mining and then incorporating strip-mining.

Without strip-mining, all the x,y,z coordinates for the four vertices must be re-fetched from memory in the second pass, that is, the lighting loop. This causes under-utilization of cache lines fetched during transformation loop as well as bandwidth wasted in the lighting loop.

Example 9-7. Data Access of a 3D Geometry Engine without Strip-mining

```

while (nvtx < MAX_NUM_VTX) {
    prefetchnta vertexi data           // v =[x,y,z,nx,ny,nz,tu,tv]
    prefetchnta vertexi+1 data
    prefetchnta vertexi+2 data
    prefetchnta vertexi+3 data
    TRANSFORMATION code                // use only x,y,z,tu,tv of a vertex
    nvtx+=4
}
while (nvtx < MAX_NUM_VTX) {
    prefetchnta vertexi data           // v =[x,y,z,nx,ny,nz,tu,tv]
                                        // x,y,z fetched again

    prefetchnta vertexi+1 data
    prefetchnta vertexi+2 data
    prefetchnta vertexi+3 data
    compute the light vectors          // use only x,y,z
    LOCAL LIGHTING code                // use only nx,ny,nz
    nvtx+=4
}

```

Now consider the code in Example 9-8 where strip-mining has been incorporated into the loops.

Example 9-8. Data Access of a 3D Geometry Engine with Strip-mining

```

while (nstrip < NUM_STRIP) {
    /* Strip-mine the loop to fit data into one way of the second-level
       cache */
    while (nvtx < MAX_NUM_VTX_PER_STRIP) {
        prefetchnta vertexi data       // v =[x,y,z,nx,ny,nz,tu,tv]
        prefetchnta vertexi+1 data
        prefetchnta vertexi+2 data
        prefetchnta vertexi+3 data
        TRANSFORMATION code
        nvtx+=4
    }
    while (nvtx < MAX_NUM_VTX_PER_STRIP) {
        /* x y z coordinates are in the second-level cache, no prefetch is
           required */
        compute the light vectors
        POINT LIGHTING code
        nvtx+=4
    }
}

```

With strip-mining, all vertex data can be kept in the cache (for example, one way of second-level cache) during the strip-mined transformation loop and reused in the lighting loop. Keeping data in the cache reduces both bus traffic and the number of prefetches used.

Table 9-2 summarizes the steps of the basic usage model that incorporates only software prefetch with strip-mining. The steps are:

- Do strip-mining: partition loops so that the dataset fits into second-level cache.
- Use PREFETCHNTA if the data is only used once or the dataset fits into 32 KBytes (one way of second-level cache). Use PREFETCHT0 if the dataset exceeds 32 KBytes.

The above steps are platform-specific and provide an implementation example. The variables NUM_STRIP and MAX_NUM_VX_PER_STRIP can be heuristically determined for peak performance for specific application on a specific platform.

Table 9-2. Software Prefetching Considerations into Strip-mining Code

Read-Once Array References	Read-Multiple-Times Array References	
	Adjacent Passes	Non-Adjacent Passes
Prefetchnta	Prefetch0, SM1	Prefetch0, SM1 (2nd Level Pollution)
Evict one way; Minimize pollution	Pay memory access cost for the first pass of each array; Amortize the first pass with subsequent passes	Pay memory access cost for the first pass of every strip; Amortize the first pass with subsequent passes

9.5.11 Hardware Prefetching and Cache Blocking Techniques

Tuning data access patterns for the automatic hardware prefetch mechanism can minimize the memory access costs of the first-pass of the read-multiple-times and some of the read-once memory references. An example of the situations of read-once memory references can be illustrated with a matrix or image transpose, reading from a column-first orientation and writing to a row-first orientation, or vice versa.

Example 9-9 shows a nested loop of data movement that represents a typical matrix/image transpose problem. If the dimension of the array are large, not only the footprint of the dataset will exceed the last level cache but cache misses will occur at large strides. If the dimensions happen to be powers of 2, aliasing condition due to finite number of way-associativity (see "Capacity Limits and Aliasing in Caches" in Chapter) will exacerbate the likelihood of cache evictions.

Example 9-9. Using HW Prefetch to Improve Read-Once Memory Traffic

```

a) Un-optimized image transpose
// dest and src represent two-dimensional arrays
for(i = 0; i < NUMCOLS; i++) {
    // inner loop reads single column
    for(j = 0; j < NUMROWS ; j++) {
        // Each read reference causes large-stride cache miss
        dest[i*NUMROWS +j] = src[j*NUMROWS + i];
    }
}
b)
// tilewidth = L2SizeInBytes/2/TileHeight/Sizeof(element)
for( i = 0; i < NUMCOLS; i += tilewidth) {
    for( j = 0; j < NUMROWS ; j++) {
        // access multiple elements in the same row in the inner loop
        // access pattern friendly to hw prefetch and improves hit rate
        for( k = 0; k < tilewidth; k++)
            dest[j+ (i+k)* NUMROWS] = src[i+k+ j* NUMROWS];
    }
}

```

Example 9-9 (b) shows applying the techniques of tiling with optimal selection of tile size and tile width to take advantage of hardware prefetch. With tiling, one can choose the size of two tiles to fit in the last level cache. Maximizing the width of each tile for memory read references enables the hardware prefetcher to initiate bus requests to read some cache lines before the code actually reference the linear addresses.

9.5.12 Single-pass versus Multi-pass Execution

An algorithm can use single- or multi-pass execution defined as follows:

- Single-pass, or unlayered execution passes a single data element through an entire computation pipeline.
- Multi-pass, or layered execution performs a single stage of the pipeline on a batch of data elements, before passing the batch on to the next stage.

A characteristic feature of both single-pass and multi-pass execution is that a specific trade-off exists depending on an algorithm's implementation and use of a single-pass or multiple-pass execution. See Figure 9-10.

Multi-pass execution is often easier to use when implementing a general purpose API, where the choice of code paths that can be taken depends on the specific combination of features selected by the application (for example, for 3D graphics, this might include the type of vertex primitives used and the number and type of light sources).

With such a broad range of permutations possible, a single-pass approach would be complicated, in terms of code size and validation. In such cases, each possible permutation would require a separate code sequence. For example, an object with features A, B, C, D can have a subset of features enabled, say, A, B, D. This stage would use one code path; another combination of enabled features would have a different code path. It makes more sense to perform each pipeline stage as a separate pass, with conditional clauses to select different features that are implemented within each stage. By using strip-mining, the number of vertices processed by each stage (for example, the batch size) can be selected to ensure that the batch stays within the processor caches through all passes. An intermediate cached buffer is used to pass the batch of vertices from one stage or pass to the next one.

Single-pass execution can be better suited to applications which limit the number of features that may be used at a given time. A single-pass approach can reduce the amount of data copying that can occur with a multi-pass engine. See Figure 9-10.

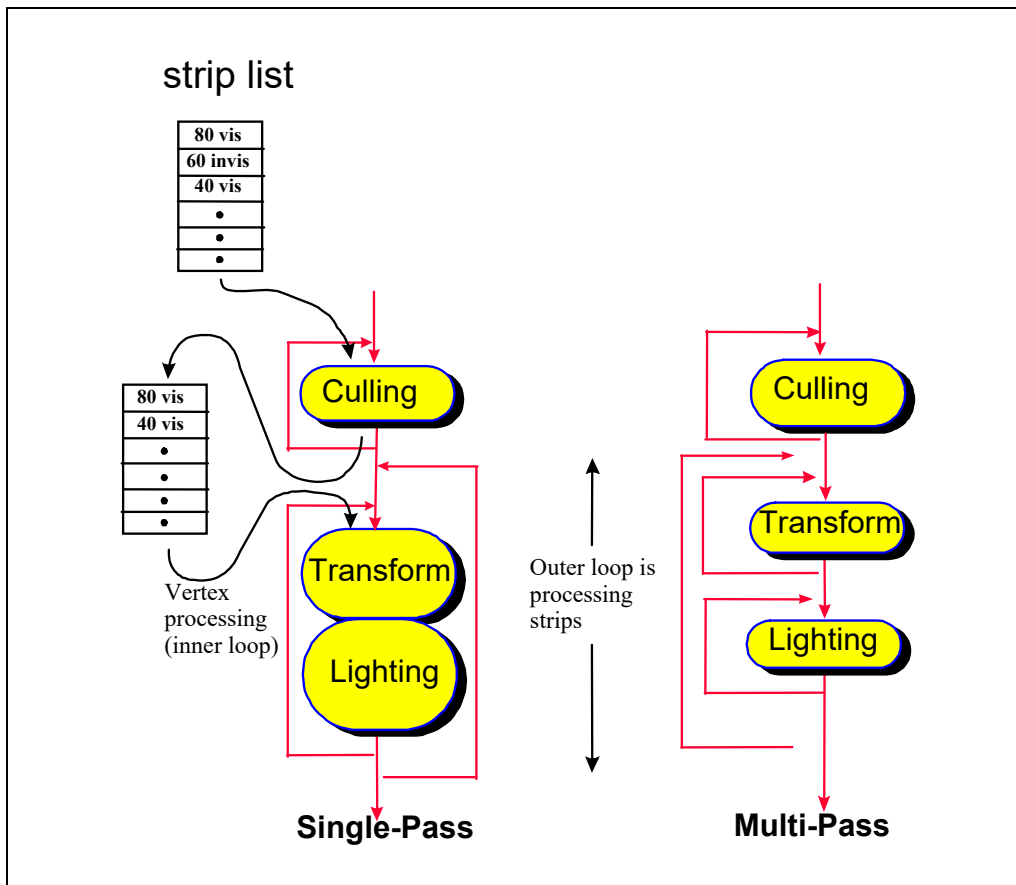

Figure 9-10. Single-Pass Vs. Multi-Pass 3D Geometry Engines

The choice of single-pass or multi-pass can have a number of performance implications. For instance, in a multi-pass pipeline, stages that are limited by bandwidth (either input or output) will reflect more of this performance limitation in overall execution time. In contrast, for a single-pass approach, bandwidth-limitations can be distributed/amortized across other computation-intensive stages. Also, the choice of which prefetch hints to use are also impacted by whether a single-pass or multi-pass approach is used.

9.6 MEMORY OPTIMIZATION USING NON-TEMPORAL STORES

Non-temporal stores can also be used to manage data retention in the cache. Uses for non-temporal stores include:

- To combine many writes without disturbing the cache hierarchy.
- To manage which data structures remain in the cache and which are transient.

Detailed implementations of these usage models are covered in the following sections.

9.6.1 Non-temporal Stores and Software Write-Combining

Use non-temporal stores in the cases when the data to be stored is:

- Write-once (non-temporal).
- Too large and thus cause cache thrashing.

Non-temporal stores do not invoke a cache line allocation, which means they are not write-allocate. As a result, caches are not polluted and no dirty writeback is generated to compete with useful data bandwidth. Without using non-temporal stores, bus bandwidth will suffer when caches start to be thrashed because of dirty writebacks.

In Streaming SIMD Extensions implementation, when non-temporal stores are written into writeback or write-combining memory regions, these stores are weakly-ordered and will be combined internally inside the processor's write-combining buffer and be written out to memory as a line burst transaction. To achieve the best possible performance, it is recommended to align data along the cache line boundary and write them consecutively in a cache line size while using non-temporal stores. If the consecutive writes are prohibitive due to programming constraints, then software write-combining (SWWC) buffers can be used to enable line burst transaction.

You can declare small SWWC buffers (a cache line for each buffer) in your application to enable explicit write-combining operations. Instead of writing to non-temporal memory space immediately, the program writes data into SWWC buffers and combines them inside these buffers. The program only writes a SWWC buffer out using non-temporal stores when the buffer is filled up, that is, a cache line. Although the SWWC method requires explicit instructions for performing temporary writes and reads, this ensures that the transaction on the front-side bus causes line transaction rather than several partial transactions. Application performance gains considerably from implementing this technique. These SWWC buffers can be maintained in the second-level and re-used throughout the program.

9.6.2 Cache Management

Streaming instructions (PREFETCH and STORE) can be used to manage data and minimize disturbance of temporal data held within the processor's caches.

In addition, the processor takes advantage of Intel C++ Compiler support for C++ language-level features for the Streaming SIMD Extensions. Streaming SIMD Extensions and MMX technology instructions provide intrinsics that allow you to optimize cache utilization. Examples of such Intel compiler intrinsics are `_MM_PREFETCH`, `_MM_STREAM`, `_MM_LOAD`, `_MM_SFENCE`. For detail, refer to the Intel C++ Compiler User's Guide documentation.

The following examples of using prefetching instructions in the operation of video encoder and decoder as well as in simple 8-byte memory copy, illustrate performance gain from using the prefetching instructions for efficient cache management.

9.6.2.1 Video Encoder

In a video encoder, some of the data used during the encoding process is kept in the processor's second-level cache. This is done to minimize the number of reference streams that must be re-read from system memory. To ensure that other writes do not disturb the data in the second-level cache, streaming stores (MOVNTQ) are used to write around all processor caches.

The prefetching cache management implemented for the video encoder reduces the memory traffic. The second-level cache pollution reduction is ensured by preventing single-use video frame data from entering the second-level cache. Using a non-temporal PREFETCH (PREFETCHNTA) instruction brings data into the first-level cache, thus reducing pollution of the second-level cache.

If the data brought directly to second-level cache is not re-used, then there is a performance gain from the non-temporal prefetch over a temporal prefetch. The encoder uses non-temporal prefetches to avoid pollution of the second-level cache, increasing the number of second-level cache hits and decreasing the number of polluting write-backs to memory. The performance gain results from the more efficient use of the second-level cache, not only from the prefetch itself.

9.6.2.2 Video Decoder

In the video decoder example, completed frame data is written to local memory of the graphics card, which is mapped to WC (Write-combining) memory type. A copy of reference data is stored to the WB memory at a later time by the processor in order to generate future data. The assumption is that the size

of the reference data is too large to fit in the processor's caches. A streaming store is used to write the data around the cache, to avoid displacing other temporal data held in the caches. Later, the processor re-reads the data using PREFETCHNTA, which ensures maximum bandwidth, yet minimizes disturbance of other cached temporal data by using the non-temporal (NTA) version of prefetch.

9.6.2.3 Conclusions from Video Encoder and Decoder Implementation

These two examples indicate that by using an appropriate combination of non-temporal prefetches and non-temporal stores, an application can be designed to lessen the overhead of memory transactions by preventing second-level cache pollution, keeping useful data in the second-level cache and reducing costly write-back transactions. Even if an application does not gain performance significantly from having data ready from prefetches, it can improve from more efficient use of the second-level cache and memory. Such design reduces the encoder's demand for such critical resource as the memory bus. This makes the system more balanced, resulting in higher performance.

9.6.2.4 Optimizing Memory Copy Routines

Creating memory copy routines for large amounts of data is a common task in software optimization. Example 9-10 presents a basic algorithm for a simple memory copy.

Example 9-10. Basic Algorithm of a Simple Memory Copy

```
#define N 512000
double a[N], b[N];
for (i = 0; i < N; i++) {
    b[i] = a[i];
}
```

This task can be optimized using various coding techniques. One technique uses software prefetch and streaming store instructions. It is discussed in the following paragraph and a code example shown in Example 9-11.

The memory copy algorithm can be optimized using the Streaming SIMD Extensions with these considerations:

- Alignment of data.
- Proper layout of pages in memory.
- Cache size.
- Interaction of the transaction lookaside buffer (TLB) with memory accesses.
- Combining prefetch and streaming-store instructions.

Example 9-11. A Memory Copy Routine Using Software Prefetch

```

#define PAGESIZE 4096;
#define NUMPERPAGE 512          // # of elements to fit a page

double a[N], b[N], temp;
for (kk=0; kk<N; kk+=NUMPERPAGE) {
    temp = a[kk+NUMPERPAGE];    // TLB priming for older archs
    // use block size = page size,
    // prefetch entire block, one cache line per loop
    for (j=kk+16; j<kk+NUMPERPAGE; j+=16) {
        _mm_prefetch((char*)&a[j], _MM_HINT_NTA);
    }
    // copy 128 byte per loop
    for (j=kk; j<kk+NUMPERPAGE; j+=16) {
        _mm_stream_ps((float*)&b[j],
            _mm_load_ps((float*)&a[j]));
        _mm_stream_ps((float*)&b[j+2],
            _mm_load_ps((float*)&a[j+2]));
        _mm_stream_ps((float*)&b[j+4],
            _mm_load_ps((float*)&a[j+4]));
        _mm_stream_ps((float*)&b[j+6],
            _mm_load_ps((float*)&a[j+6]));
        _mm_stream_ps((float*)&b[j+8],
            _mm_load_ps((float*)&a[j+8]));
        _mm_stream_ps((float*)&b[j+10],
            _mm_load_ps((float*)&a[j+10]));
        _mm_stream_ps((float*)&b[j+12],
            _mm_load_ps((float*)&a[j+12]));
        _mm_stream_ps((float*)&b[j+14],
            _mm_load_ps((float*)&a[j+14]));
    } // finished copying one block
} // finished copying N elements
_mm_sfence();

```

9.6.2.5 Using the 8-byte Streaming Stores and Software Prefetch

Example 9-11 presents the copy algorithm that uses second level cache. The algorithm performs the following steps:

1. Uses blocking technique to transfer 8-byte data from memory into second-level cache using the `_MM_PREFETCH` intrinsic, 128 bytes at a time to fill a block. The size of a block should be less than one half of the size of the second-level cache, but large enough to amortize the cost of the loop.
2. Loads the data into an XMM register using the `_MM_LOAD_PS` intrinsic.
3. Transfers the 8-byte data to a different memory location via the `_MM_STREAM` intrinsics, bypassing the cache.

In Example 9-11, eight `_MM_LOAD_PS` and `_MM_STREAM_PS` intrinsics are used so that all of the data prefetched (a 128-byte cache line) is written back. The prefetch and streaming-stores are executed in separate loops to minimize the number of transitions between reading and writing data. This significantly improves the bandwidth of the memory accesses.

The `TEMP = A[KK+CACHESIZE]` instruction is used to ensure the page table entry for array in older architectures, and `A` is entered in the TLB prior to prefetching. This is essentially a prefetch itself, as a cache line is filled from that memory location with this instruction. Hence, the prefetching starts from `KK+4` in this loop.

This example assumes that the destination of the copy is not temporally adjacent to the code. If the copied data is destined to be reused in the near future, then the streaming store instructions should be replaced with regular 128 bit stores (`_MM_STORE_PS`).

9.6.2.6 Using 16-byte Streaming Stores and Hardware Prefetch

An alternate technique for optimizing a large region memory copy is to take advantage of hardware prefetcher, 16-byte streaming stores, and apply a segmented approach to separate bus read and write transactions. See Section 3.6.11, “Non-Temporal Store Bus Traffic.”

The technique employs two stages. In the first stage, a block of data is read from memory to the cache sub-system. In the second stage, cached data are written to their destination using streaming stores.

Example 9-12. Memory Copy Using Hardware Prefetch and Bus Segmentation

```
void block_prefetch(void *dst,void *src)
{
    _asm {
        mov edi,dst
        mov esi,src
        mov edx,SIZE
        align 16
    main_loop:
        xor ecx,ecx
        align 16
    }

    prefetch_loop:
        movaps xmm0,[esi+ecx]
        movaps xmm0,[esi+ecx+64]
        add ecx,128
        cmp ecx,BLOCK_SIZE
        jne prefetch_loop
        xor ecx,ecx
        align 16
    cpy_loop:

        movdqa xmm0,[esi+ecx]
        movdqa xmm1,[esi+ecx+16]
        movdqa xmm2,[esi+ecx+32]
        movdqa xmm3,[esi+ecx+48]
        movdqa xmm4,[esi+ecx+64]
        movdqa xmm5,[esi+ecx+16+64]
        movdqa xmm6,[esi+ecx+32+64]
        movdqa xmm7,[esi+ecx+48+64]
        movntdq [edi+ecx],xmm0
        movntdq [edi+ecx+16],xmm1
        movntdq [edi+ecx+32],xmm2
    }
```

Example 9-12. Memory Copy Using Hardware Prefetch and Bus Segmentation (Contd.)

```

movntdq [edi+ecx+48],xmm3
movntdq [edi+ecx+64],xmm4
movntdq [edi+ecx+80],xmm5
movntdq [edi+ecx+96],xmm6
movntdq [edi+ecx+112],xmm7
add ecx,128
cmp ecx,BLOCK_SIZE
jne cpy_loop

add esi,ecx
add edi,ecx
sub edx,ecx
jnz main_loop
sfence
}
}

```

9.6.2.7 Performance Comparisons of Memory Copy Routines

The throughput of a large-region, memory copy routine depends on several factors:

- Coding techniques that implements the memory copy task.
- Characteristics of the system bus (speed, peak bandwidth, overhead in read/write transaction protocols).
- Microarchitecture of the processor.

The baseline for performance comparison is the throughput (bytes/sec) of 8-MByte region memory copy on a first-generation Pentium M processor (CUID signature 0x69n) with a 400-MHz system bus using byte-sequential technique similar to that shown in Example 9-10. The degree of improvement relative to the performance baseline for some recent processors and platforms with higher system bus speed using different coding techniques are compared.

The second coding technique moves data at 4-Byte granularity using REP string instruction. The third column compares the performance of the coding technique listed in Example 9-11. The fourth column of performance compares the throughput of fetching 4-KBytes of data at a time (using hardware prefetch to aggregate bus read transactions) and writing to memory via 16-Byte streaming stores.

Increases in bus speed is the primary contributor to throughput improvements. The technique shown in Example 9-12 will likely take advantage of the faster bus speed in the platform more efficiently. Additionally, increasing the block size to multiples of 4-KBytes while keeping the total working set within the second-level cache can improve the throughput slightly.

The relative performance figure shown in Table 9-3 is representative of clean microarchitectural conditions within a processor (e.g. looping a simple sequence of code many times). The net benefit of integrating a specific memory copy routine into an application (full-featured applications tend to create many complicated micro-architectural conditions) will vary for each application.

9.6.3 Deterministic Cache Parameters

If CUID supports the deterministic parameter leaf, software can use the leaf to query each level of the cache hierarchy. Enumeration of each cache level is by specifying an index value (starting from 0) in the ECX register (see "CUID-CPU Identification" in Chapter 3 of the *Intel® 64 and IA-32 Architectures Software Developer's Manual, Volume 2A*).

The list of parameters is shown in Table 9-3.

Table 9-3. Deterministic Cache Parameters Leaf

Bit Location	Name	Meaning
EAX[4:0]	Cache Type	0 = Null - No more caches 1 = Data Cache 2 = Instruction Cache 3 = Unified Cache 4-31 = Reserved
EAX[7:5]	Cache Level	Starts at 1
EAX[8]	Self Initializing cache level	1: does not need SW initialization
EAX[9]	Fully Associative cache	1: Yes
EAX[13:10]	Reserved	
EAX[25:14]	Maximum number of logical processors sharing this cache	Plus 1 encoding
EAX[31:26]	Maximum number of cores in a package	Plus 1 encoding
EBX[11:0]	System Coherency Line Size (L)	Plus 1 encoding (Bytes)
EBX[21:12]	Physical Line partitions (P)	Plus 1 encoding
EBX[31:22]	Ways of associativity (W)	Plus 1 encoding
ECX[31:0]	Number of Sets (S)	Plus 1 encoding
EDX	Reserved	
CPIUD leaves > 3 < 80000000 are only visible when IA32_CR_MISC_ENABLES.BOOT_NT4 (bit 22) is clear (Default).		

The deterministic cache parameter leaf provides a means to implement software with a degree of forward compatibility with respect to enumerating cache parameters. Deterministic cache parameters can be used in several situations, including:

- Determine the size of a cache level.
- Adapt cache blocking parameters to different sharing topology of a cache-level across Hyper-Threading Technology, multicore and single-core processors.
- Determine multithreading resource topology in an MP system (See [Chapter 9, "Multiple-Processor Management,"](#) of the *Intel® 64 and IA-32 Architectures Software Developer's Manual, Volume 3A*).
- Determine cache hierarchy topology in a platform using multicore processors (See topology enumeration white paper and reference code listed at the end of CHAPTER 1).
- Manage threads and processor affinities.
- Determine prefetch stride.

The size of a given level of cache is given by:

$$(\# \text{ of Ways}) * (\text{Partitions}) * (\text{Line_size}) * (\text{Sets}) = (\text{EBX}[31:22] + 1) * (\text{EBX}[21:12] + 1) * (\text{EBX}[11:0] + 1) * (\text{ECX} + 1)$$

9.6.3.1 Cache Sharing Using Deterministic Cache Parameters

Improving cache locality is an important part of software optimization. For example, a cache blocking algorithm can be designed to optimize block size at runtime for single-processor implementations and a variety of multiprocessor execution environments (including processors supporting HT Technology, or multicore processors).

The basic technique is to place an upper limit of the blocksize to be less than the size of the target cache level divided by the number of logical processors serviced by the target level of cache. This technique is applicable to multithreaded application programming. The technique can also benefit single-threaded applications that are part of a multi-tasking workloads.

9.6.3.2 Cache Sharing in Single-Core or Multicore

Deterministic cache parameters are useful for managing shared cache hierarchy in multithreaded applications for more sophisticated situations. A given cache level may be shared by logical processors in a processor or it may be implemented to be shared by logical processors in a physical processor package.

Using the deterministic cache parameter leaf and initial APIC_ID associated with each logical processor in the platform, software can extract information on the number and the topological relationship of logical processors sharing a cache level.

9.6.3.3 Determine Prefetch Stride

The prefetch stride (see description of CPUID.01H.EBX) provides the length of the region that the processor will prefetch with the PREFETCHh instructions (PREFETCHT0, PREFETCHT1, PREFETCHT2 and PREFETCHNTA). Software will use the length as the stride when prefetching into a particular level of the cache hierarchy as identified by the instruction used. The prefetch size is relevant for cache types of Data Cache (1) and Unified Cache (3); it should be ignored for other cache types. Software should not assume that the coherency line size is the prefetch stride.

If the prefetch stride field is zero, then software should assume a default size of 64 bytes is the prefetch stride. Software should use the following algorithm to determine what prefetch size to use depending on whether the deterministic cache parameter mechanism is supported or the legacy mechanism:

- If a processor supports the deterministic cache parameters and provides a non-zero prefetch size, then that prefetch size is used.
- If a processor supports the deterministic cache parameters and does not provides a prefetch size then default size for each level of the cache hierarchy is 64 bytes.
- If a processor does not support the deterministic cache parameters but provides a legacy prefetch size descriptor (0xF0 - 64 byte, 0xF1 - 128 byte) will be the prefetch size for all levels of the cache hierarchy.
- If a processor does not support the deterministic cache parameters and does not provide a legacy prefetch size descriptor, then 32-bytes is the default size for all levels of the cache hierarchy.

Sub-NUMA Clustering (SNC) is a mode for improving average latency from last level cache (LLC) to local memory. It replaces the Cluster-on-Die (COD) implementation which was used in the previous generation of the Intel® Xeon® processor E5 family.

10.1 SUB-NUMA CLUSTERING

SNC can improve the average LLC/memory latency by splitting the LLC into disjoint clusters based on address range, with each cluster bound to a subset of memory controllers in the system.

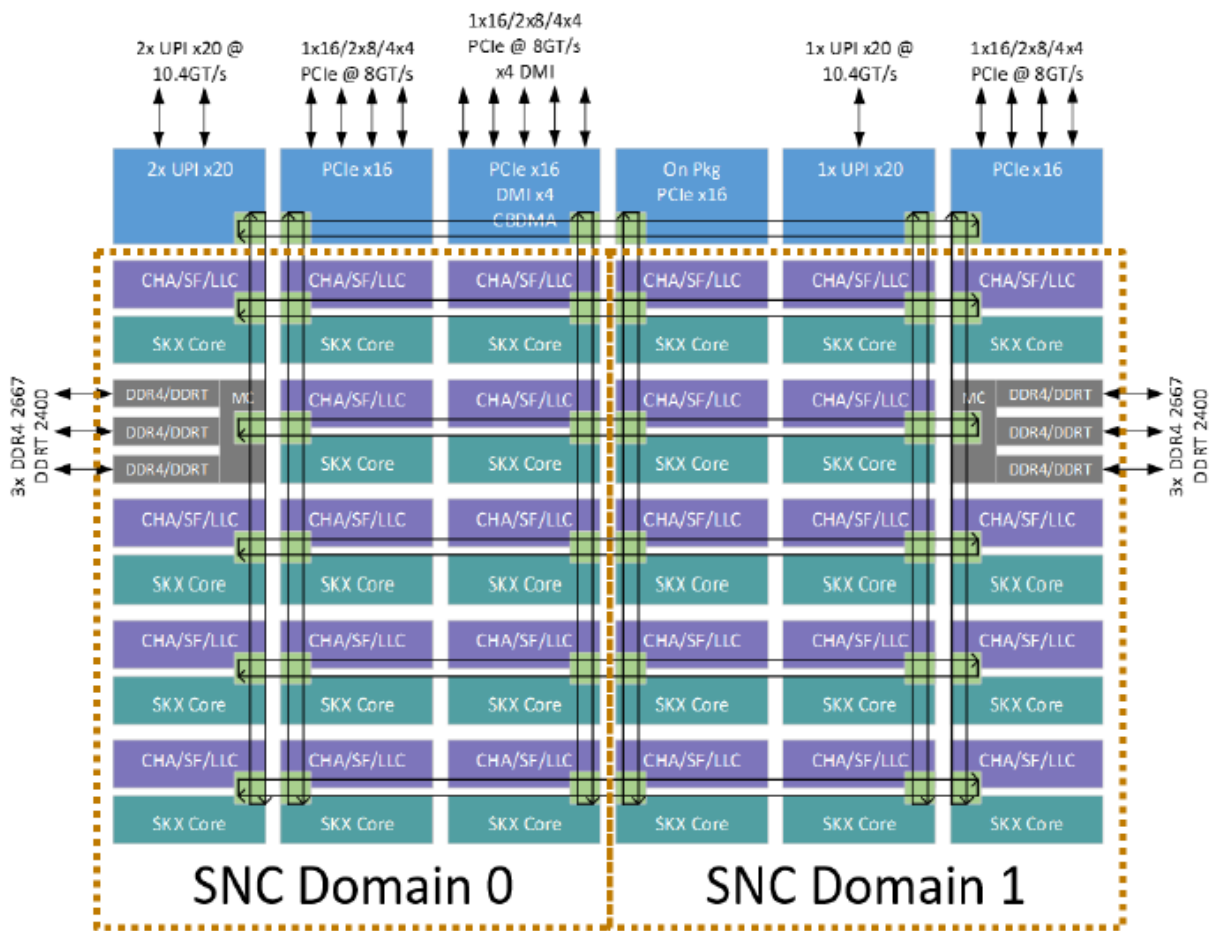

Figure 10-1. Example of SNC Configuration

10.2 COMPARISON WITH CLUSTER-ON-DIE

SNC provides similar localization benefits to those of COD, but without some of COD's disadvantages. Unlike COD, SNC has the following properties.

- Only one Ultra Path Interconnect (UPI) caching agent is required.
- Memory access latency in remote clusters is smaller, as no UPI flow is needed.
- It uses LLC capacity more efficiently as there is no duplication of lines in the LLC.

A disadvantage of SNC is listed below.

- Remote cluster addresses are never cached in local cluster LLC, resulting in larger latency compared to Cluster-on-Die (COD) in some cases.

10.3 SNC USAGE

This section describes the following modes and their BIOS names in brackets (the exact BIOS parameter names may vary depending on the BIOS vendor and version).

- NUMA disabled (NUMA Optimized: Disabled)
- SNC off (Integrated Memory Controller (IMC) Interleaving: auto, NUMA Optimized: Enabled, Sub_NUMA Cluster: Disabled)
- SNC on (IMC Interleaving: 1-way Interleave, NUMA Optimized: Enabled, Sub_NUMA Cluster: Enabled)

The commands that follow were executed on a 2-socket Intel[®] Xeon[®] system, 28 cores per a socket, Intel[®] Hyper-Threading Technology enabled.

10.3.1 How to Check NUMA Configuration

There are additional NUMA nodes in a system with SNC enabled; to get benefits from the SNC feature, a developer should be aware of the NUMA configuration.

This chapter describes different ways to check NUMA system configuration.

libnuma

An application can check NUMA configuration with `libnuma`.

As an example this code uses the `libnuma` library to find the maximum number of NUMA nodes.

```
#include <stdio.h>
#include <stdlib.h>
#include <numa.h>

int main(int argc, char *argv[])
{
    int max_node;

    /* Check the system for NUMA support */
    max_node = numa_max_node();
    printf("%d\n", max_node);

    return 0;
}
```

numactl

In Linux* you can check the NUMA configuration with the `numactl` utility (the `numactl-libs`, and `numactl-devel` packages might also be required).

```
$ numactl --hardware
```

NUMA disabled:

```
available: 1 nodes (0)
node 0 cpus: 0 1 2 3 4 5 6 7 8 9 10 11 12 13 14 15 16 17 18 19 20 21 22
23 24 25 26 27 28 29 30 31 32 33 34 35 36 37 38 39 40 41 42 43 44 45 46
47 48 49 50 51 52 53 54 55 56 57 58 59 60 61 62 63 64 65 66 67 68 69 70
71 72 73 74 75 76 77 78 79 80 81 82 83 84 85 86 87 88 89 90 91 92 93 94
95 96 97 98 99 100 101 102 103 104 105 106 107 108 109 110 111
node 0 size: 196045 MB
node 0 free: 190581 MB
node distances:
node 0
  0: 10
```

SNC off:

```
available: 2 nodes (0-1)
node 0 cpus: 0 1 2 3 4 5 6 7 8 9 10 11 12 13 14 15 16 17 18 19 20 21 22
23 24 25 26 27 56 57 58 59 60 61 62 63 64 65 66 67 68 69 70 71 72 73 74
75 76 77 78 79 80 81 82 83
node 0 size: 96973 MB
node 0 free: 94089 MB
node 1 cpus: 28 29 30 31 32 33 34 35 36 37 38 39 40 41 42 43 44 45 46 47
48 49 50 51 52 53 54 55 84 85 86 87 88 89 90 91 92 93 94 95 96 97 98 99
100 101 102 103 104 105 106 107 108 109 110 111
node 1 size: 98304 MB
node 1 free: 95694 MB
node distances:
node 0 1
  0: 10 21
  1: 21 10
```

SUB-NUMA CLUSTERING

SNC on:

```
available: 4 nodes (0-3)
node 0 cpus: 0 1 2 3 7 8 9 14 15 16 17 21 22 23 56 57 58 59 63 64 65 70
71 72 73 77 78 79
node 0 size: 47821 MB
node 0 free: 45759 MB
node 1 cpus: 4 5 6 10 11 12 13 18 19 20 24 25 26 27 60 61 62 66 67 68 69
74 75 76 80 81 82 83
node 1 size: 49152 MB
node 1 free: 47097 MB
node 2 cpus: 28 29 30 31 35 36 37 42 43 44 45 49 50 51 84 85 86 87 91 92
93 98 99 100 101 105 106 107
node 2 size: 49152 MB
node 2 free: 47617 MB
node 3 cpus: 32 33 34 38 39 40 41 46 47 48 52 53 54 55 88 89 90 94 95 96
97 102 103 104 108 109 110 111
node 3 size: 49152 MB
node 3 free: 47231 MB
node distances:
node  0  1  2  3
  0:  10  11  21  21
  1:  11  10  21  21
  2:  21  21  10  11
  3:  21  21  11  10
```

hwloc

In Linux* you can also check the NUMA configuration with the `lstopo` utility (the `hwloc` package is required). For example:

```
$ lstopo -p --of png --no-io --no-caches > numa_topology.png
```

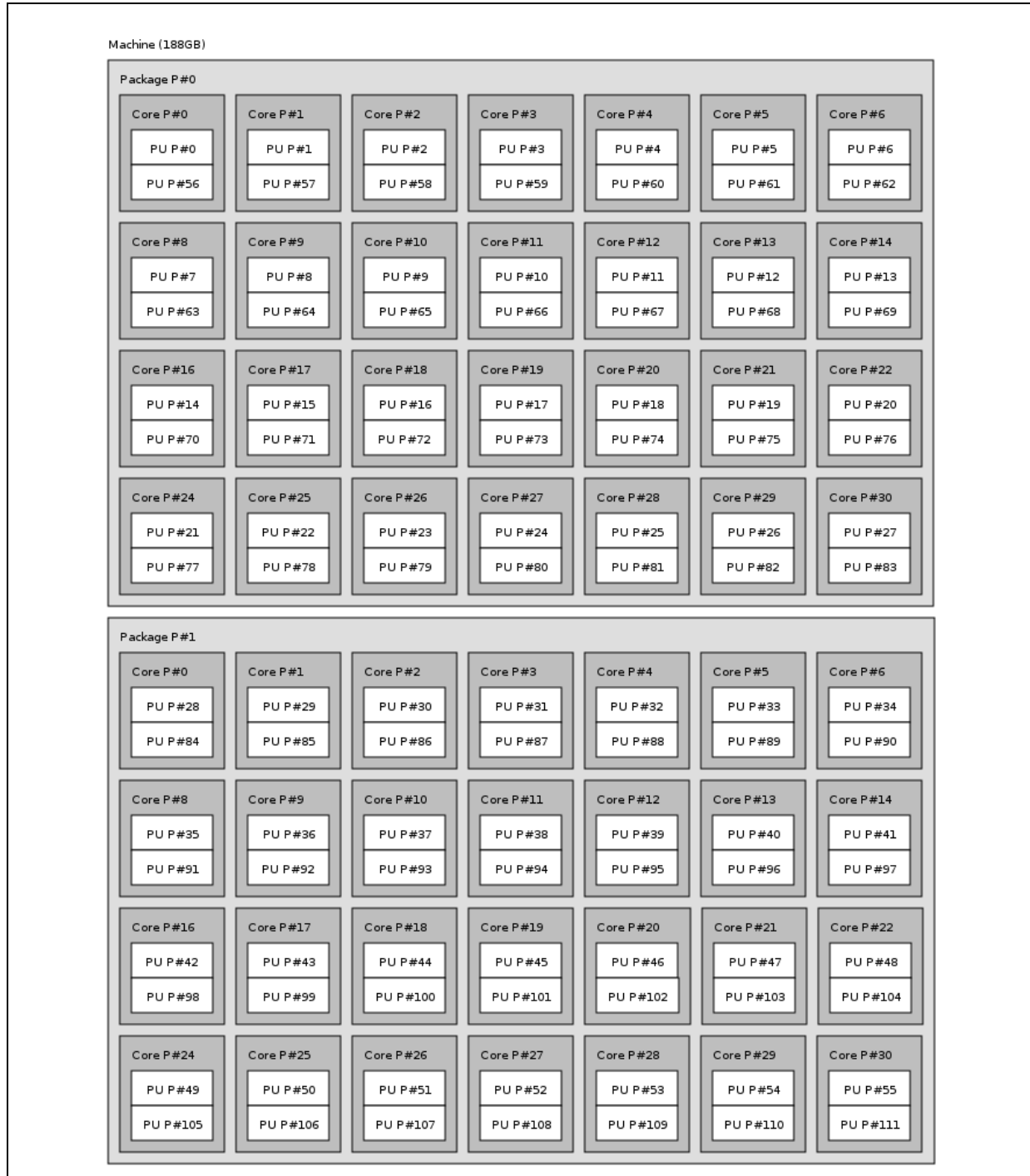

Figure 10-2. NUMA Disabled

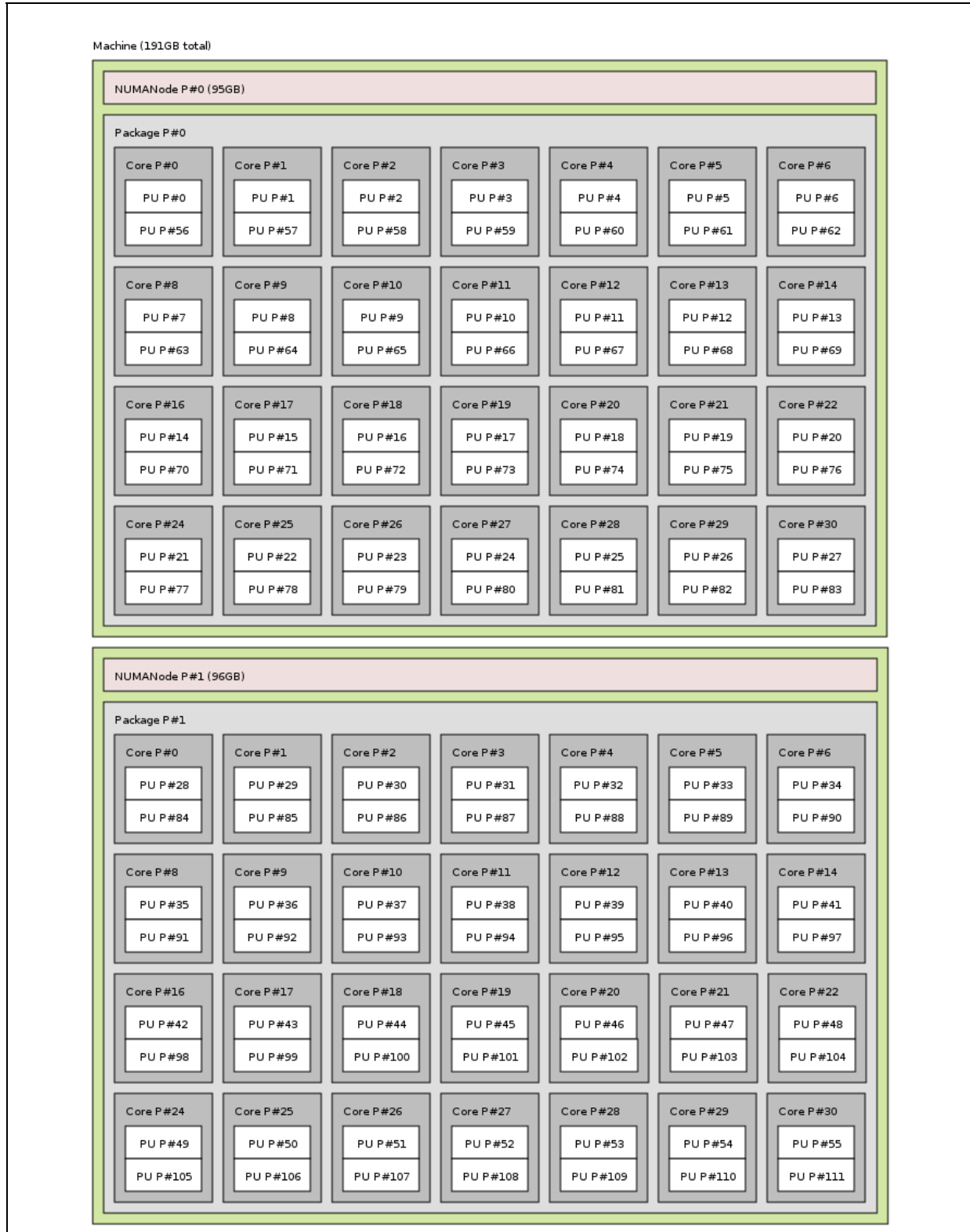

Figure 10-3. SNC Off



Figure 10-4. SNC On

10.3.2 MPI Optimizations for SNC

Software needs to be NUMA optimized to benefit from SNC. Running one MPI rank per NUMA region trivially ensures locality-of-access without requiring changes to the code to ensure that it behaves in a NUMA friendly manner. This is a simple way to improve performance through the use of SNC.

The Intel[®] MPI Library includes some NUMA-related optimizations. The out-of-the-box behavior of the Intel MPI Library should cover most cases, but there are some environment variables available to control NUMA-related features that can improve performance in specific cases.

The relevant environment variables mainly relate to MPI process placement, that is, process pinning/binding – such as the `I_MPI_PIN_DOMAIN` variable. For more information, see the Intel[®] MPI Library Developer Reference. This environment variable defines a number of non-overlapping subsets (domains) of logical processors on a node, and a set of rules for how MPI processes are bound to these domains: one MPI process per domain, as illustrated below.

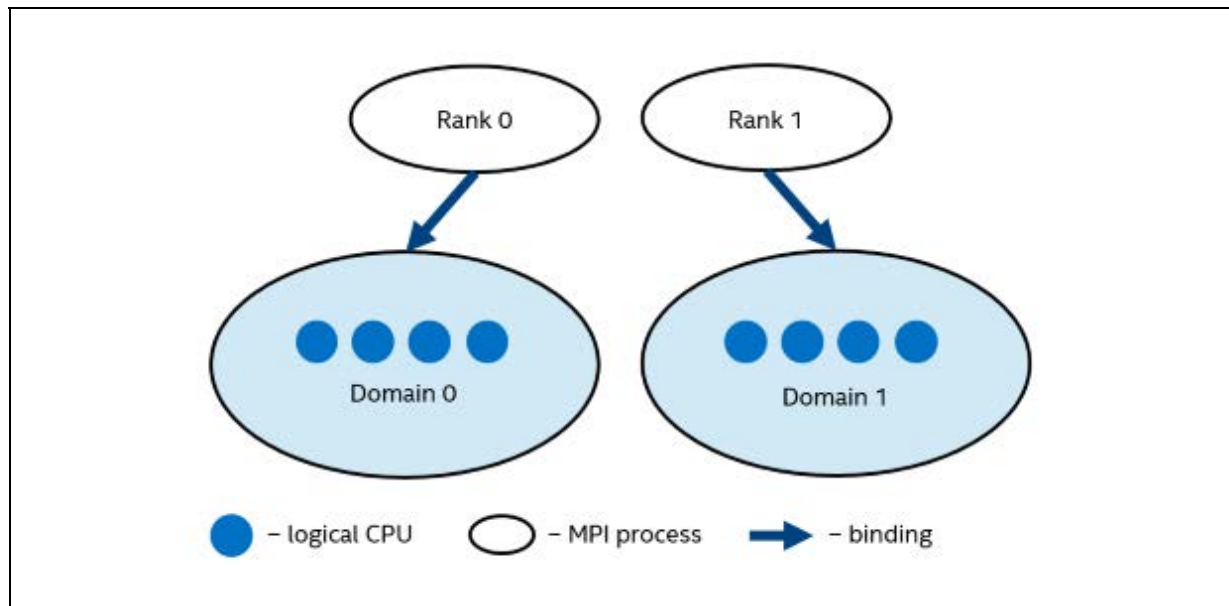

Figure 10-5. Domain Example with One MPI Process Per Domain

Each MPI process can create a number of child threads to run within the corresponding domain. The process' threads can freely migrate from one logical processor to another within the particular domain.

For example, `I_MPI_PIN_DOMAIN=numa` may be a reasonable option for hybrid MPI/OpenMP* applications with SNC mode enabled. In this case, each domain consists of logical processors that share a particular NUMA node. The number of domains on a machine is equal to the number of NUMA nodes on the machine.

Refer to Intel MPI Library documentation for detailed information: <https://software.intel.com/en-us/intel-mpi-library/documentation>.

10.3.3 SNC Performance Comparison

This section contains performance data collected with Intel® Memory Latency Checker (Intel® MLC) to demonstrate the variations in performance (latency) between NUMA nodes in different modes.

An important factor in determining application performance is the time required for the application to fetch data from the processor's cache hierarchy and from the memory subsystem. Local memory and cross-socket memory latencies vary significantly in a NUMA-enabled multi-socket system. Bandwidth also plays an important role in determining performance. So measuring these latencies and bandwidths is important when establishing a baseline for the system being tested, and performing performance analysis.

Intel MLC is a tool used to measure memory latencies and bandwidth, and how they change as the load on the system increases. It also provides several options for more fine-grained investigation where bandwidth and latencies from a specific set of cores to caches or memory can be measured as well.

See <https://software.intel.com/en-us/articles/intelr-memory-latency-checker> for details about Intel® MLC.

The following command was used to collect the performance data:

```
% mlc_avx512 --latency_matrix
```

This command measures idle memory latency from each socket in the system to every other socket and reports the results in a matrix. The default invocation reports latencies to all of the NUMA nodes in the system. NUMA-level reporting works only on Linux. On Windows, only socket level reporting is supported.

NOTE

It is challenging to measure memory latencies on modern Intel processors accurately as they have sophisticated HW prefetchers. Intel MLC automatically disables these prefetchers while measuring the latencies and restores them to their previous state on completion. The prefetcher control is exposed through an MSR (see <https://software.intel.com/en-us/articles/disclosure-of-hw-prefetcher-control-on-some-intel-processors> for details) and MSR access requires root level permission. So, Intel MLC needs to be run as `'root'` on Linux.

The software configuration used for these measurements is Intel MLC v3.3-Beta2, Red Hat* Linux* 7.2.

NUMA disabled:

Using buffer size of 2000.000MB

Measuring idle latencies (in ns)...

Memory node

Socket	0	1
0	126.5	129.4
1	123.1	122.6

SNC off:

Using buffer size of 2000.000MB

Measuring idle latencies (in ns)...

Numa node

Numa node	0	1
0	81.9	153.1
1	153.7	82.0

SNC on:

Using buffer size of 2000.000MB

Measuring idle latencies (in ns)...

Numa node

Numa node	0	1	2	3
0	81.6	89.4	140.4	153.6
1	86.5	78.5	144.3	162.8
2	142.3	153.0	81.6	89.3
3	144.5	162.8	85.5	77.4

CHAPTER 11

MULTICORE AND HYPER-THREADING TECHNOLOGY

This chapter describes software optimization techniques for multithreaded applications running in an environment using either multiprocessor (MP) systems or processors with hardware-based multi-threading support. Multiprocessor systems are systems with two or more sockets, each mated with a physical processor package. Intel 64 and IA-32 processors that provide hardware multithreading support include dual-core processors, quad-core processors and processors supporting HT Technology¹.

Computational throughput in a multithreading environment can increase as more hardware resources are added to take advantage of thread-level or task-level parallelism. Hardware resources can be added in the form of more than one physical-processor, processor-core-per-package, and/or logical-processor-per-core. Therefore, there are some aspects of multithreading optimization that apply across MP, multi-core, and HT Technology. There are also some specific microarchitectural resources that may be implemented differently in different hardware multithreading configurations (for example: execution resources are not shared across different cores but shared by two logical processors in the same core if HT Technology is enabled). This chapter covers guidelines that apply to these situations.

This chapter covers:

- Performance characteristics and usage models.
- Programming models for multithreaded applications.
- Software optimization techniques in five specific areas.

11.1 PERFORMANCE AND USAGE MODELS

The performance gains of using multiple processors, multicore processors or HT Technology are greatly affected by the usage model and the amount of parallelism in the control flow of the workload. Two common usage models are:

- Multithreaded applications.
- Multitasking using single-threaded applications.

11.1.1 Multithreading

When an application employs multithreading to exploit task-level parallelism in a workload, the control flow of the multi-threaded software can be divided into two parts: parallel tasks and sequential tasks.

Amdahl's law describes an application's performance gain as it relates to the degree of parallelism in the control flow. It is a useful guide for selecting the code modules, functions, or instruction sequences that are most likely to realize the most gains from transforming sequential tasks and control flows into parallel code to take advantage multithreading hardware support.

Figure 11-1 illustrates how performance gains can be realized for any workload according to Amdahl's law. The bar in Figure 11-1 represents an individual task unit or the collective workload of an entire application.

1. The presence of hardware multithreading support in Intel 64 and IA-32 processors can be detected by checking the feature flag CPUID .01H:EDX[28]. A return value of in bit 28 indicates that at least one form of hardware multithreading is present in the physical processor package. The number of logical processors present in each package can also be obtained from CPUID. The application must check how many logical processors are enabled and made available to application at runtime by making the appropriate operating system calls. See the *Intel® 64 and IA-32 Architectures Software Developer's Manual, Volume 2A* for information.

In general, the speed-up of running multiple threads on an MP systems with N physical processors, over single-threaded execution, can be expressed as:

$$\text{RelativeResponse} = \frac{T_{\text{sequential}}}{T_{\text{parallel}}} = \left(1 - P + \frac{P}{N} + O \right)$$

where P is the fraction of workload that can be parallelized, and O represents the overhead of multi-threading and may vary between different operating systems. In this case, performance gain is the inverse of the relative response.

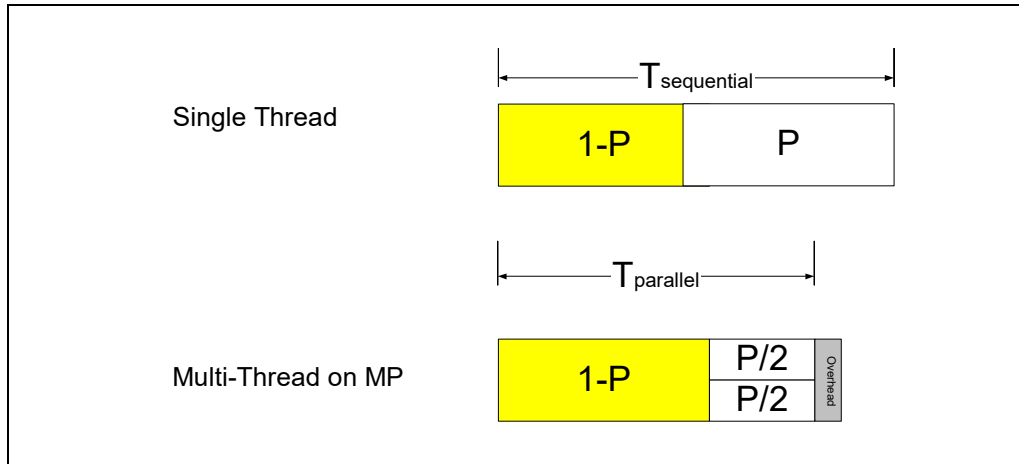

Figure 11-1. Amdahl's Law and MP Speed-up

When optimizing application performance in a multithreaded environment, control flow parallelism is likely to have the largest impact on performance scaling with respect to the number of physical processors and to the number of logical processors per physical processor.

If the control flow of a multi-threaded application contains a workload in which only 50% can be executed in parallel, the maximum performance gain using two physical processors is only 33%, compared to using a single processor. Using four processors can deliver no more than a 60% speed-up over a single processor. Thus, it is critical to maximize the portion of control flow that can take advantage of parallelism. Improper implementation of thread synchronization can significantly increase the proportion of serial control flow and further reduce the application's performance scaling.

In addition to maximizing the parallelism of control flows, interaction between threads in the form of thread synchronization and imbalance of task scheduling can also impact overall processor scaling significantly.

Excessive cache misses are one cause of poor performance scaling. In a multithreaded execution environment, they can occur from:

- Aliased stack accesses by different threads in the same process.
- Thread contentions resulting in cache line evictions.
- False-sharing of cache lines between different processors.

Techniques that address each of these situations (and many other areas) are described in sections in this chapter.

11.1.2 Multitasking Environment

Hardware multithreading capabilities in Intel 64 and IA-32 processors can exploit task-level parallelism when a workload consists of several single-threaded applications and these applications are scheduled to run concurrently under an MP-aware operating system. In this environment, hardware multithreading capabilities can deliver higher throughput for the workload, although the relative performance of a single

task (in terms of time of completion relative to the same task when in a single-threaded environment) will vary, depending on how much shared execution resources and memory are utilized.

For development purposes, several popular operating systems (for example Microsoft Windows* XP Professional and Home, Linux* distributions using kernel 2.4.19 or later¹) include OS kernel code that can manage the task scheduling and the balancing of shared execution resources within each physical processor to maximize the throughput.

Because applications run independently under a multitasking environment, thread synchronization issues are less likely to limit the scaling of throughput. This is because the control flow of the workload is likely to be 100% parallel² (if no inter-processor communication is taking place and if there are no system bus constraints).

With a multitasking workload, however, bus activities and cache access patterns are likely to affect the scaling of the throughput. Running two copies of the same application or same suite of applications in a lock-step can expose an artifact in performance measuring methodology. This is because an access pattern to the first level data cache can lead to excessive cache misses and produce skewed performance results. Fix this problem by:

- Including a per-instance offset at the start-up of an application.
- Introducing heterogeneity in the workload by using different datasets with each instance of the application.
- Randomizing the sequence of start-up of applications when running multiple copies of the same suite.

When two applications are employed as part of a multitasking workload, there is little synchronization overhead between these two processes. It is also important to ensure each application has minimal synchronization overhead within itself.

An application that uses lengthy spin loops for intra-process synchronization is less likely to benefit from HT Technology in a multitasking workload. This is because critical resources will be consumed by the long spin loops.

11.2 PROGRAMMING MODELS AND MULTITHREADING

Parallelism is the most important concept in designing a multithreaded application and realizing optimal performance scaling with multiple processors. An optimized multithreaded application is characterized by large degrees of parallelism or minimal dependencies in the following areas:

- Workload.
- Thread interaction.
- Hardware utilization.

The key to maximizing workload parallelism is to identify multiple tasks that have minimal inter-dependencies within an application and to create separate threads for parallel execution of those tasks.

Concurrent execution of independent threads is the essence of deploying a multithreaded application on a multiprocessing system. Managing the interaction between threads to minimize the cost of thread synchronization is also critical to achieving optimal performance scaling with multiple processors.

Efficient use of hardware resources between concurrent threads requires optimization techniques in specific areas to prevent contentions of hardware resources. Coding techniques for optimizing thread synchronization and managing other hardware resources are discussed in subsequent sections.

Parallel programming models are discussed next.

1. This code is included in Red Hat* Linux Enterprise AS 2.1.
 2. A software tool that attempts to measure the throughput of a multitasking workload is likely to introduce control flows that are not parallel. Thread synchronization issues must be considered as an integral part of its performance measuring methodology.

11.2.1 Parallel Programming Models

Two common programming models for transforming independent task requirements into application threads are:

- Domain decomposition.
- Functional decomposition.

11.2.1.1 Domain Decomposition

Usually large compute-intensive tasks use data sets that can be divided into a number of small subsets, each having a large degree of computational independence. Examples include:

- Computation of a discrete cosine transformation (DCT) on two-dimensional data by dividing the two-dimensional data into several subsets and creating threads to compute the transform on each subset.
- Matrix multiplication; here, threads can be created to handle the multiplication of half of matrix with the multiplier matrix.

Domain Decomposition is a programming model based on creating identical or similar threads to process smaller pieces of data independently. This model can take advantage of duplicated execution resources present in a traditional multiprocessor system. It can also take advantage of shared execution resources between two logical processors in HT Technology. This is because a data domain thread typically consumes only a fraction of the available on-chip execution resources.

Section 11.3.4, “Key Practices of Execution Resource Optimization,” discusses additional guidelines that can help data domain threads use shared execution resources cooperatively and avoid the pitfalls creating contentions of hardware resources between two threads.

11.2.2 Functional Decomposition

Applications usually process a wide variety of tasks with diverse functions and many unrelated data sets. For example, a video codec needs several different processing functions. These include DCT, motion estimation and color conversion. Using a functional threading model, applications can program separate threads to do motion estimation, color conversion, and other functional tasks.

Functional decomposition will achieve more flexible thread-level parallelism if it is less dependent on the duplication of hardware resources. For example, a thread executing a sorting algorithm and a thread executing a matrix multiplication routine are not likely to require the same execution unit at the same time. A design recognizing this could advantage of traditional multiprocessor systems as well as multiprocessor systems using processors supporting HT Technology.

11.2.3 Specialized Programming Models

Intel Core Duo processor and processors based on Intel Core microarchitecture offer a second-level cache shared by two processor cores in the same physical package. This provides opportunities for two application threads to access some application data while minimizing the overhead of bus traffic.

Multi-threaded applications may need to employ specialized programming models to take advantage of this type of hardware feature. One such scenario is referred to as producer-consumer. In this scenario, one thread writes data into some destination (hopefully in the second-level cache) and another thread executing on the other core in the same physical package subsequently reads data produced by the first thread.

The basic approach for implementing a producer-consumer model is to create two threads; one thread is the producer and the other is the consumer. Typically, the producer and consumer take turns to work on a buffer and inform each other when they are ready to exchange buffers. In a producer-consumer model, there is some thread synchronization overhead when buffers are exchanged between the producer and consumer. To achieve optimal scaling with the number of cores, the synchronization overhead must be kept low. This can be done by ensuring the producer and consumer threads have comparable time constants for completing each incremental task prior to exchanging buffers.

Example 11-1 illustrates the coding structure of single-threaded execution of a sequence of task units, where each task unit (either the producer or consumer) executes serially (shown in Figure 11-2). In the equivalent scenario under multi-threaded execution, each producer-consumer pair is wrapped as a thread function and two threads can be scheduled on available processor resources simultaneously.

Example 11-1. Serial Execution of Producer and Consumer Work Items

```
for (i = 0; i < number_of_iterations; i++) {
    producer (i, buff); // pass buffer index and buffer address
    consumer (i, buff);
}
```

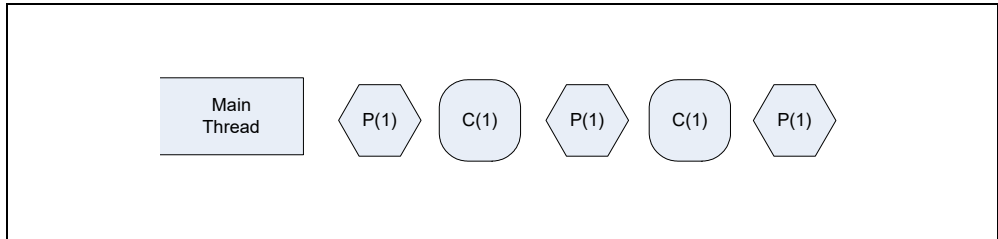

Figure 11-2. Single-threaded Execution of Producer-consumer Threading Model

11.2.3.1 Producer-Consumer Threading Models

Figure 11-3 illustrates the basic scheme of interaction between a pair of producer and consumer threads. The horizontal direction represents time. Each block represents a task unit, processing the buffer assigned to a thread.

The gap between each task represents synchronization overhead. The decimal number in the parenthesis represents a buffer index. On an Intel Core Duo processor, the producer thread can store data in the second-level cache to allow the consumer thread to continue work requiring minimal bus traffic.

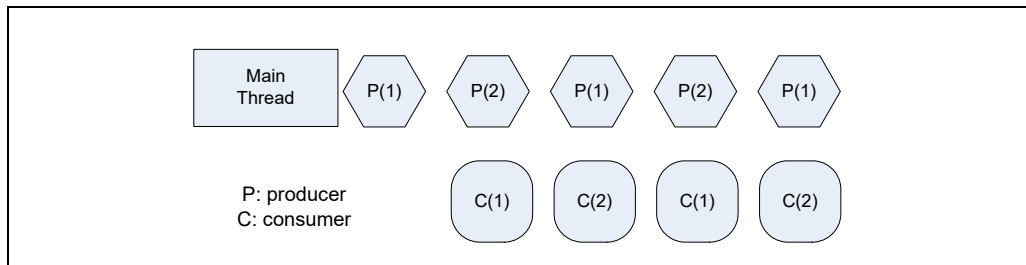

Figure 11-3. Execution of Producer-consumer Threading Model on a Multicore Processor

The basic structure to implement the producer and consumer thread functions with synchronization to communicate buffer index is shown in Example 11-2.

Example 11-2. Basic Structure of Implementing Producer Consumer Threads

```

(a) Basic structure of a producer thread function
void producer_thread()
{
    int iter_num = workamount - 1; // make local copy
    int mode1 = 1; // track usage of two buffers via 0 and 1
    produce(bufs[0],count); // placeholder function
    while (iter_num--> 0) {

        Signal(&signal1,1); // tell the other thread to commence
        produce(bufs[mode1],count); // placeholder function
        WaitForSignal(&end1);
        mode1 = 1 - mode1; // switch to the other buffer
    }
}

b) Basic structure of a consumer thread
void consumer_thread()
{
    int mode2 = 0; // first iteration start with buffer 0, than alternate
    int iter_num = workamount - 1;
    while (iter_num--> 0) {

        WaitForSignal(&signal1);
        consume(bufs[mode2],count); // placeholder function
        Signal(&end1,1);
        mode2 = 1 - mode2;
    }
    consume(bufs[mode2],count);
}

```

It is possible to structure the producer-consumer model in an interlaced manner such that it can minimize bus traffic and be effective on multicore processors without shared second-level cache.

In this interlaced variation of the producer-consumer model, each scheduling quanta of an application thread comprises of a producer task and a consumer task. Two identical threads are created to execute in parallel. During each scheduling quanta of a thread, the producer task starts first and the consumer task follows after the completion of the producer task; both tasks work on the same buffer. As each task completes, one thread signals to the other thread notifying its corresponding task to use its designated buffer. Thus, the producer and consumer tasks execute in parallel in two threads. As long as the data generated by the producer reside in either the first or second level cache of the same core, the consumer can access them without incurring bus traffic. The scheduling of the interlaced producer-consumer model is shown in Figure 11-4.

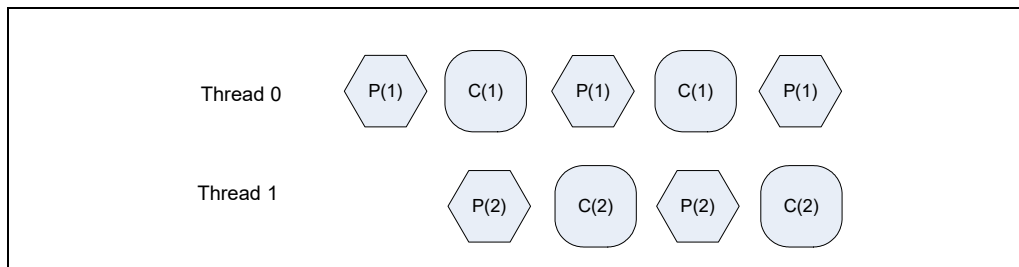

Figure 11-4. Interlaced Variation of the Producer Consumer Model

Example 11-3 shows the basic structure of a thread function that can be used in this interlaced producer-consumer model.

Example 11-3. Thread Function for an Interlaced Producer Consumer Model

```
// master thread starts first iteration, other thread must wait
// one iteration
void producer_consumer_thread(int master)
{
    int mode = 1 - master; // track which thread and its designated
                          // buffer index
    unsigned int iter_num = workamount >> 1;
    unsigned int i=0;

    iter_num += master & workamount & 1;

    if (master) // master thread starts the first iteration
    {
        produce(bufs[mode],count);
        Signal(sigp[1-mode],1); // notify producer task in follower
                               // thread that it can proceed

        consume(bufs[mode],count);
        Signal(sic[1-mode],1);
        i = 1;
    }

    for (; i < iter_num; i++)
    {
        WaitForSignal(sigp[mode]);
        produce(bufs[mode],count); // notify the producer task in
                                   // other thread

        Signal(sigp[1-mode],1);

        WaitForSignal(sic[mode]);
        consume(bufs[mode],count);
        Signal(sic[1-mode],1);
    }
}
```

11.2.4 Tools for Creating Multithreaded Applications

Programming directly to a multithreading application programming interface (API) is not the only method for creating multithreaded applications. New tools (such as the Intel compiler) have become available with capabilities that make the challenge of creating multithreaded application easier.

Features available in the latest Intel compilers are:

- Generating multithreaded code using OpenMP* directives¹.
- Generating multithreaded code automatically from unmodified high-level code².

1. Intel Compiler 5.0 and later supports OpenMP directives. Visit <http://software.intel.com> for details.

2. Intel Compiler 6.0 supports auto-parallelization.

11.2.4.1 Programming with OpenMP Directives

OpenMP provides a standardized, non-proprietary, portable set of Fortran and C++ compiler directives supporting shared memory parallelism in applications. OpenMP supports directive-based processing. This uses special preprocessors or modified compilers to interpret parallelism expressed in Fortran comments or C/C++ pragmas. Benefits of directive-based processing include:

- The original source can be compiled unmodified.
- It is possible to make incremental code changes. This preserves algorithms in the original code and enables rapid debugging.
- Incremental code changes help programmers maintain serial consistency. When the code is run on one processor, it gives the same result as the unmodified source code.
- Offering directives to fine tune thread scheduling imbalance.
- Intel's implementation of OpenMP runtime can add minimal threading overhead relative to hand-coded multithreading.

11.2.4.2 Automatic Parallelization of Code

While OpenMP directives allow programmers to quickly transform serial applications into parallel applications, programmers must identify specific portions of the application code that contain parallelism and add compiler directives. Intel Compiler 6.0 supports a new (-QPARALLEL) option, which can identify loop structures that contain parallelism. During program compilation, the compiler automatically attempts to decompose the parallelism into threads for parallel processing. No other intervention or programmer is needed.

11.2.4.3 Supporting Development Tools

See Appendix A, "Application Performance Tools" for information on the various tools that Intel provides for software development.

11.3 OPTIMIZATION GUIDELINES

This section summarizes optimization guidelines for tuning multithreaded applications. Five areas are listed (in order of importance):

- Thread synchronization.
- Bus utilization.
- Memory optimization.
- Front end optimization.
- Execution resource optimization.

Practices associated with each area are listed in this section. Guidelines for each area are discussed in greater depth in sections that follow.

Most of the coding recommendations improve performance scaling with processor cores; and scaling due to HT Technology. Techniques that apply to only one environment are noted.

11.3.1 Key Practices of Thread Synchronization

Key practices for minimizing the cost of thread synchronization are summarized below:

- Insert the PAUSE instruction in fast spin loops and keep the number of loop repetitions to a minimum to improve overall system performance.
- Replace a spin-lock that may be acquired by multiple threads with pipelined locks such that no more than two threads have write accesses to one lock. If only one thread needs to write to a variable shared by two threads, there is no need to acquire a lock.

- Use a thread-blocking API in a long idle loop to free up the processor.
- Prevent “false-sharing” of per-thread-data between two threads.
- Place each synchronization variable alone, separated by 128 bytes or in a separate cache line.

See Section 11.4, “Thread Synchronization,” for details.

11.3.2 Key Practices of System Bus Optimization

Managing bus traffic can significantly impact the overall performance of multithreaded software and MP systems. Key practices of system bus optimization for achieving high data throughput and quick response are:

- Improve data and code locality to conserve bus command bandwidth.
- Avoid excessive use of software prefetch instructions and allow the automatic hardware prefetcher to work. Excessive use of software prefetches can significantly and unnecessarily increase bus utilization if used inappropriately.
- Consider using overlapping multiple back-to-back memory reads to improve effective cache miss latencies.
- Use full write transactions to achieve higher data throughput.

See Section 11.5, “System Bus Optimization,” for details.

11.3.3 Key Practices of Memory Optimization

Key practices for optimizing memory operations are summarized below:

- Use cache blocking to improve locality of data access. Target one quarter to one half of cache size when targeting processors supporting HT Technology.
- Minimize the sharing of data between threads that execute on different physical processors sharing a common bus.
- Minimize data access patterns that are offset by multiples of 64-KBytes in each thread.
- Adjust the private stack of each thread in an application so the spacing between these stacks is not offset by multiples of 64 KBytes or 1 MByte (prevents unnecessary cache line evictions) when targeting processors supporting HT Technology.
- Add a per-instance stack offset when two instances of the same application are executing in lock steps to avoid memory accesses that are offset by multiples of 64 KByte or 1 MByte when targeting processors supporting HT Technology.

See Section 11.6, “Memory Optimization,” for details.

11.3.4 Key Practices of Execution Resource Optimization

Each physical processor has dedicated execution resources. Logical processors in physical processors supporting HT Technology share specific on-chip execution resources. Key practices for execution resource optimization include:

- Optimize each thread to achieve optimal frequency scaling first.
- Optimize multithreaded applications to achieve optimal scaling with respect to the number of physical processors.
- Use on-chip execution resources cooperatively if two threads are sharing the execution resources in the same physical processor package.
- For each processor supporting HT Technology, consider adding functionally uncorrelated threads to increase the hardware resource utilization of each physical processor package.

See Section 11.8, “Affinities and Managing Shared Platform Resources,” for details.

11.3.5 Generality and Performance Impact

The next five sections cover the optimization techniques in detail. Recommendations discussed in each section are ranked by importance in terms of estimated local impact and generality.

Rankings are subjective and approximate. They can vary depending on coding style, application and threading domain. The purpose of including high, medium and low impact ranking with each recommendation is to provide a relative indicator as to the degree of performance gain that can be expected when a recommendation is implemented.

It is not possible to predict the likelihood of a code instance across many applications, so an impact ranking cannot be directly correlated to application-level performance gain. The ranking on generality is also subjective and approximate.

Coding recommendations that do not impact all three scaling factors are typically categorized as medium or lower.

11.4 THREAD SYNCHRONIZATION

Applications with multiple threads use synchronization techniques in order to ensure correct operation. However, thread synchronization that are improperly implemented can significantly reduce performance.

The best practice to reduce the overhead of thread synchronization is to start by reducing the application's requirements for synchronization. Intel Thread Profiler can be used to profile the execution timeline of each thread and detect situations where performance is impacted by frequent occurrences of synchronization overhead.

Several coding techniques and operating system (OS) calls are frequently used for thread synchronization. These include spin-wait loops, spin-locks, critical sections, to name a few. Choosing the optimal OS call for the circumstance and implementing synchronization code with parallelism in mind are critical in minimizing the cost of handling thread synchronization.

SSE3 provides two instructions (MONITOR/MWAIT) to help multithreaded software improve synchronization between multiple agents. In the first implementation of MONITOR and MWAIT, these instructions are available to operating system so that operating system can optimize thread synchronization in different areas. For example, an operating system can use MONITOR and MWAIT in its system idle loop (known as C0 loop) to reduce power consumption. An operating system can also use MONITOR and MWAIT to implement its C1 loop to improve the responsiveness of the C1 loop. See [Chapter 9](#) in the Intel® 64 and IA-32 Architectures Software Developer's Manual, Volume 3A.

11.4.1 Choice of Synchronization Primitives

Thread synchronization often involves modifying some shared data while protecting the operation using synchronization primitives. There are many primitives to choose from. Guidelines that are useful when selecting synchronization primitives are:

- Favor compiler intrinsics or an OS provided interlocked API for atomic updates of simple data operation, such as increment and compare/exchange. This will be more efficient than other more complicated synchronization primitives with higher overhead.

For more information on using different synchronization primitives, see the white paper *Developing Multi-threaded Applications: A Platform Consistent Approach*. See <https://software.intel.com/sites/default/files/article/147714/51534-developing-multithreaded-applications.pdf>.

- When choosing between different primitives to implement a synchronization construct, using Intel Thread Checker and Thread Profiler can be very useful in dealing with multithreading functional correctness issue and performance impact under multi-threaded execution. Additional information on the capabilities of Intel Thread Checker and Thread Profiler are described in Appendix A.

Table 11-1 is useful for comparing the properties of three categories of synchronization objects available to multi-threaded applications.

Table 11-1. Properties of Synchronization Objects

Characteristics	Operating System Synchronization Objects	Light Weight User Synchronization	Synchronization Object based on MONITOR/MWAIT
Cycles to acquire and release (if there is a contention)	Thousands or Tens of thousands cycles	Hundreds of cycles	Hundreds of cycles
Power consumption	Saves power by halting the core or logical processor if idle	Some power saving if using PAUSE	Saves more power than PAUSE
Scheduling and context switching	Returns to the OS scheduler if contention exists (can be tuned with earlier spin loop count)	Does not return to OS scheduler voluntarily	Does not return to OS scheduler voluntarily
Ring level	Ring 0	Ring 3	Ring 0
Miscellaneous	Some objects provide intra-process synchronization and some are for inter-process communication	Must lock accesses to synchronization variable if several threads may write to it simultaneously. Otherwise can write without locks.	Same as light weight. Can be used only on systems supporting MONITOR/MWAIT
Recommended use conditions	<ul style="list-style-type: none"> ▪ Number of active threads is greater than number of cores ▪ Waiting thousands of cycles for a signal ▪ Synchronization among processes 	<ul style="list-style-type: none"> ▪ Number of active threads is less than or equal to number of cores ▪ Infrequent contention ▪ Need inter process synchronization 	<ul style="list-style-type: none"> ▪ Same as light weight objects ▪ MONITOR/MWAIT available

11.4.2 Synchronization for Short Periods

The frequency and duration that a thread needs to synchronize with other threads depends application characteristics. When a synchronization loop needs very fast response, applications may use a spin-wait loop.

A spin-wait loop is typically used when one thread needs to wait a short amount of time for another thread to reach a point of synchronization. A spin-wait loop consists of a loop that compares a synchronization variable with some pre-defined value. See Example 11-4(a).

On a modern microprocessor with a superscalar speculative execution engine, a loop like this results in the issue of multiple simultaneous read requests from the spinning thread. These requests usually execute out-of-order with each read request being allocated a buffer resource. On detection of a write by a worker thread to a load that is in progress, the processor must guarantee no violations of memory order occur. The necessity of maintaining the order of outstanding memory operations inevitably costs the processor a severe penalty that impacts all threads.

This penalty occurs on the Pentium M processor, the Intel Core Solo and Intel Core Duo processors. However, the penalty on these processors is small compared with penalties suffered on the Pentium 4 and Intel Xeon processors. There the performance penalty for exiting the loop is about 25 times more severe.

On a processor supporting HT Technology, spin-wait loops can consume a significant portion of the execution bandwidth of the processor. One logical processor executing a spin-wait loop can severely impact the performance of the other logical processor.

Example 11-4. Spin-wait Loop and PAUSE Instructions

(a) An un-optimized spin-wait loop experiences performance penalty when exiting the loop. It consumes execution resources without contributing computational work.

```
do {
    // This loop can run faster than the speed of memory access,
    // other worker threads cannot finish modifying sync_var until
    // outstanding loads from the spinning loops are resolved.
} while( sync_var != constant_value);
```

(b) Inserting the PAUSE instruction in a fast spin-wait loop prevents performance-penalty to the spinning thread and the worker thread

```
do {
    _asm pause
    // Ensure this loop is de-pipelined, i.e. preventing more than one
    // load request to sync_var to be outstanding,
    // avoiding performance penalty when the worker thread updates
    // sync_var and the spinning thread exiting the loop.
}
while( sync_var != constant_value);
```

(c) A spin-wait loop using a “test, test-and-set” technique to determine the availability of the synchronization variable. This technique is recommended when writing spin-wait loops to run on Intel 64 and IA-32 architecture processors.

```
Spin_Lock:
    CMP lockvar, 0;           // Check if lock is free.
    JE Get_lock
    PAUSE;                   // Short delay.
    JMP Spin_Lock;
Get_Lock:
    MOV EAX, 1;
    XCHG EAX, lockvar;       // Try to get lock.
    CMP EAX, 0;             // Test if successful.
    JNE Spin_Lock;
Critical_Section:
    <critical section code>
    MOV lockvar, 0;         // Release lock.
```

User/Source Coding Rule 14. (M impact, H generality) Insert the PAUSE instruction in fast spin loops and keep the number of loop repetitions to a minimum to improve overall system performance.

The penalty of exiting from a spin-wait loop can be avoided by inserting a PAUSE instruction in the loop. In spite of the name, the PAUSE instruction improves performance by introducing a slight delay in the loop and effectively causing the memory read requests to be issued at a rate that allows immediate detection of any store to the synchronization variable. This prevents the occurrence of a long delay due to memory order violation.

One example of inserting the PAUSE instruction in a simplified spin-wait loop is shown in Example 11-4(b). The PAUSE instruction is compatible with all Intel 64 and IA-32 processors. On IA-32 processors prior to Intel NetBurst microarchitecture, the PAUSE instruction is essentially a NOP instruction. Additional examples of optimizing spin-wait loops using the PAUSE instruction are available in Application note AP-949, “Using Spin-Loops on Intel Pentium 4 Processor and Intel Xeon Processor.” See <https://software.intel.com/sites/default/files/22/30/25602>.

Inserting the PAUSE instruction has the added benefit of significantly reducing the power consumed during the spin-wait because fewer system resources are used.

11.4.3 Optimization with Spin-Locks

Spin-locks are typically used when several threads need to modify a synchronization variable and the synchronization variable must be protected by a lock to prevent un-intentional overwrites. When the lock is released, however, several threads may compete to acquire it at once. Such thread contention significantly reduces performance scaling with respect to frequency, number of discrete processors, and HT Technology.

To reduce the performance penalty, one approach is to reduce the likelihood of many threads competing to acquire the same lock. Apply a software pipelining technique to handle data that must be shared between multiple threads.

Instead of allowing multiple threads to compete for a given lock, no more than two threads should have write access to a given lock. If an application must use spin-locks, include the PAUSE instruction in the wait loop. Example 11-4(c) shows an example of the “test, test-and-set” technique for determining the availability of the lock in a spin-wait loop.

User/Source Coding Rule 15. (M impact, L generality) *Replace a spin lock that may be acquired by multiple threads with pipelined locks such that no more than two threads have write accesses to one lock. If only one thread needs to write to a variable shared by two threads, there is no need to use a lock.*

11.4.4 Synchronization for Longer Periods

When using a spin-wait loop not expected to be released quickly, an application should follow these guidelines:

- Keep the duration of the spin-wait loop to a minimum number of repetitions.
- Applications should use an OS service to block the waiting thread; this can release the processor so that other runnable threads can make use of the processor or available execution resources.

On processors supporting HT Technology, operating systems should use the HLT instruction if one logical processor is active and the other is not. HLT will allow an idle logical processor to transition to a halted state; this allows the active logical processor to use all the hardware resources in the physical package. An operating system that does not use this technique must still execute instructions on the idle logical processor that repeatedly check for work. This “idle loop” consumes execution resources that could otherwise be used to make progress on the other active logical processor.

If an application thread must remain idle for a long time, the application should use a thread blocking API or other method to release the idle processor. The techniques discussed here apply to traditional MP system, but they have an even higher impact on processors that support HT Technology.

Typically, an operating system provides timing services, for example `Sleep(dwMilliseconds)`¹; such variables can be used to prevent frequent checking of a synchronization variable.

Another technique to synchronize between worker threads and a control loop is to use a thread-blocking API provided by the OS. Using a thread-blocking API allows the control thread to use less processor cycles for spinning and waiting. This gives the OS more time quanta to schedule the worker threads on available processors. Furthermore, using a thread-blocking API also benefits from the system idle loop optimization that OS implements using the HLT instruction.

User/Source Coding Rule 16. (H impact, M generality) *Use a thread-blocking API in a long idle loop to free up the processor.*

Using a spin-wait loop in a traditional MP system may be less of an issue when the number of runnable threads is less than the number of processors in the system. If the number of threads in an application is expected to be greater than the number of processors (either one processor or multiple processors), use a thread-blocking API to free up processor resources. A multithreaded application adopting one control thread to synchronize multiple worker threads may consider limiting worker threads to the number of processors in a system and use thread-blocking APIs in the control thread.

1. The `Sleep()` API is not thread-blocking, because it does not guarantee the processor will be released. Example 11-5(a) shows an example of using `Sleep(0)`, which does not always realize the processor to another thread.

11.4.4.1 Avoid Coding Pitfalls in Thread Synchronization

Synchronization between multiple threads must be designed and implemented with care to achieve good performance scaling with respect to the number of discrete processors and the number of logical processor per physical processor. No single technique is a universal solution for every synchronization situation.

The pseudo-code example in Example 11-5(a) illustrates a polling loop implementation of a control thread. If there is only one runnable worker thread, an attempt to call a timing service API, such as Sleep(0), may be ineffective in minimizing the cost of thread synchronization. Because the control thread still behaves like a fast spinning loop, the only runnable worker thread must share execution resources with the spin-wait loop if both are running on the same physical processor that supports HT Technology. If there are more than one runnable worker threads, then calling a thread blocking API, such as Sleep(0), could still release the processor running the spin-wait loop, allowing the processor to be used by another worker thread instead of the spinning loop.

A control thread waiting for the completion of worker threads can usually implement thread synchronization using a thread-blocking API or a timing service, if the worker threads require significant time to complete. Example 11-5(b) shows an example that reduces the overhead of the control thread in its thread synchronization.

Example 11-5. Coding Pitfall using Spin Wait Loop

(a) A spin-wait loop attempts to release the processor incorrectly. It experiences a performance penalty if the only worker thread and the control thread runs on the same physical processor package.

```
// Only one worker thread is running,
// the control loop waits for the worker thread to complete.
```

```
ResumeWorkThread(thread_handle);
While (!task_not_done ) {
    Sleep(0) // Returns immediately back to spin loop.
    ...
}
```

(b) A polling loop frees up the processor correctly.

```
// Let a worker thread run and wait for completion.
ResumeWorkThread(thread_handle);
While (!task_not_done ) {
    Sleep(FIVE_MILLISEC)

// This processor is released for some duration, the processor
// can be used by other threads.
    ...
}
```

In general, OS function calls should be used with care when synchronizing threads. When using OS-supported thread synchronization objects (critical section, mutex, or semaphore), preference should be given to the OS service that has the least synchronization overhead, such as a critical section.

11.4.5 Prevent Sharing of Modified Data and False-Sharing

Depending on the cache topology relative to processor/core topology and the specific underlying microarchitecture, sharing of modified data can incur some degree of performance penalty when a software thread running on one core tries to read or write data that is currently present in modified state in the local cache of another core. This will cause eviction of the modified cache line back into memory and reading it into the first-level cache of the other core. The latency of such cache line transfer is much higher than using data in the immediate first level cache or second level cache.

False sharing applies to data used by one thread that happens to reside on the same cache line as different data used by another thread. These situations can also incur a performance delay depending on the topology of the logical processors/cores in the platform.

False sharing can experience a performance penalty when the threads are running on logical processors reside on different physical processors or processor cores. For processors that support HT Technology, false-sharing incurs a performance penalty when two threads run on different cores, different physical processors, or on two logical processors in the physical processor package. In the first two cases, the performance penalty is due to cache evictions to maintain cache coherency. In the latter case, performance penalty is due to memory order machine clear conditions.

A generic approach for multi-threaded software to prevent incurring false-sharing penalty is to allocate separate critical data or locks with alignment granularity according to a "false-sharing threshold" size. The following steps will allow software to determine the "false-sharing threshold" across Intel processors:

1. If the processor supports CLFLUSH instruction, i.e. CPUID.01H:EDX.CLFLUSH[bit 19] =1:
Use the CLFLUSH line size, i.e. the integer value of CPUID.01H:EBX[15:8], as the "false-sharing threshold".
2. If CLFLUSH line size is not available, use CPUID leaf 4 as described below:
Determine the "false-sharing threshold" by evaluating the largest system coherency line size among valid cache types that are reported via the sub-leaves of CPUID leaf 4. For each sub-leaf n, its associated system coherency line size is (CPUID.(EAX=4, ECX=n):EBX[11:0] + 1).
3. If neither CLFLUSH line size is available, nor CPUID leaf 4 is available, then software may choose the "false-sharing threshold" from one of the following:
 - a. Query the descriptor tables of CPUID leaf 2 and choose from available descriptor entries.
 - b. A Family/Model-specific mechanism available in the platform or a Family/Model-specific known value.
 - c. Default to a safe value 64 bytes.

User/Source Coding Rule 17. (H impact, M generality) Beware of false sharing within a cache line or within a sector. Allocate critical data or locks separately using alignment granularity not smaller than the "false-sharing threshold".

When a common block of parameters is passed from a parent thread to several worker threads, it is desirable for each work thread to create a private copy (each copy aligned to multiples of the "false-sharing threshold") of frequently accessed data in the parameter block.

11.4.6 Placement of Shared Synchronization Variable

On processors based on Intel NetBurst microarchitecture, bus reads typically fetch 128 bytes into a cache, the optimal spacing to minimize eviction of cached data is 128 bytes. To prevent false-sharing, synchronization variables and system objects (such as a critical section) should be allocated to reside alone in a 128-byte region and aligned to a 128-byte boundary.

Example 11-6 shows a way to minimize the bus traffic required to maintain cache coherency in MP systems. This technique is also applicable to MP systems using processors with or without HT Technology.

Example 11-6. Placement of Synchronization and Regular Variables

```
int regVar;
int padding[32];
int SynVar[32*NUM_SYNC_VARS];
int AnotherVar;
```

On Pentium M, Intel Core Solo, Intel Core Duo processors, and processors based on Intel Core microarchitecture; a synchronization variable should be placed alone and in separate cache line to avoid false-sharing. Software must not allow a synchronization variable to span across page boundary.

User/Source Coding Rule 18. (M impact, ML generality) Place each synchronization variable alone, separated by 128 bytes or in a separate cache line.

User/Source Coding Rule 19. (H impact, L generality) Do not place any spin lock variable to span a cache line boundary.

At the code level, false sharing is a special concern in the following cases:

- Global data variables and static data variables that are placed in the same cache line and are written by different threads.
- Objects allocated dynamically by different threads may share cache lines. Make sure that the variables used locally by one thread are allocated in a manner to prevent sharing the cache line with other threads.

Another technique to enforce alignment of synchronization variables and to avoid a cacheline being shared is to use compiler directives when declaring data structures. See Example 11-7.

Example 11-7. Declaring Synchronization Variables without Sharing a Cache Line

```
__declspec(align(64)) unsigned __int64 sum;
struct sync_struct {...};
__declspec(align(64)) struct sync_struct sync_var;
```

Other techniques that prevent false-sharing include:

- Organize variables of different types in data structures (because the layout that compilers give to data variables might be different than their placement in the source code).
- When each thread needs to use its own copy of a set of variables, declare the variables with:
 - Directive `threadprivate`, when using OpenMP.
 - Modifier `__declspec (thread)`, when using Microsoft compiler.
- In managed environments that provide automatic object allocation, the object allocators and garbage collectors are responsible for layout of the objects in memory so that false sharing through two objects does not happen.
- Provide classes such that only one thread writes to each object field and close object fields, in order to avoid false sharing.

One should not equate the recommendations discussed in this section as favoring a sparsely populated data layout. The data-layout recommendations should be adopted when necessary and avoid unnecessary bloat in the size of the work set.

11.5 SYSTEM BUS OPTIMIZATION

The system bus services requests from bus agents (e.g. logical processors) to fetch data or code from the memory sub-system. The performance impact due data traffic fetched from memory depends on the characteristics of the workload, and the degree of software optimization on memory access, locality enhancements implemented in the software code. A number of techniques to characterize memory traffic of a workload is discussed in Appendix A. Optimization guidelines on locality enhancement is also discussed in Section 3.6.10, "Locality Enhancement," and Section 9.5.11, "Hardware Prefetching and Cache Blocking Techniques."

The techniques described in Chapter 3 and Chapter 9 benefit application performance in a platform where the bus system is servicing a single-threaded environment. In a multi-threaded environment, the bus system typically services many more logical processors, each of which can issue bus requests inde-

pendently. Thus, techniques on locality enhancements, conserving bus bandwidth, reducing large-stride-cache-miss-delay can have strong impact on processor scaling performance.

11.5.1 Conserve Bus Bandwidth

In a multithreading environment, bus bandwidth may be shared by memory traffic originated from multiple bus agents (These agents can be several logical processors and/or several processor cores). Preserving the bus bandwidth can improve processor scaling performance. Also, effective bus bandwidth typically will decrease if there are significant large-stride cache-misses. Reducing the amount of large-stride cache misses (or reducing DTLB misses) will alleviate the problem of bandwidth reduction due to large-stride cache misses.

One way for conserving available bus command bandwidth is to improve the locality of code and data. Improving the locality of data reduces the number of cache line evictions and requests to fetch data. This technique also reduces the number of instruction fetches from system memory.

User/Source Coding Rule 20. (M impact, H generality) *Improve data and code locality to conserve bus command bandwidth.*

Using a compiler that supports profiler-guided optimization can improve code locality by keeping frequently used code paths in the cache. This reduces instruction fetches. Loop blocking can also improve the data locality. Other locality enhancement techniques can also be applied in a multithreading environment to conserve bus bandwidth (see Section 9.5, “Memory Optimization Using Prefetch”).

Because the system bus is shared between many bus agents (logical processors or processor cores), software tuning should recognize symptoms of the bus approaching saturation. One useful technique is to examine the queue depth of bus read traffic. When the bus queue depth is high, locality enhancement to improve cache utilization will benefit performance more than other techniques, such as inserting more software prefetches or masking memory latency with overlapping bus reads. An approximate working guideline for software to operate below bus saturation is to check if bus read queue depth is significantly below 5.

Some MP and workstation platforms may have a chipset that provides two system buses, with each bus servicing one or more physical processors. The guidelines for conserving bus bandwidth described above also applies to each bus domain.

11.5.2 Understand the Bus and Cache Interactions

Be careful when parallelizing code sections with data sets that results in the total working set exceeding the second-level cache and /or consumed bandwidth exceeding the capacity of the bus. On an Intel Core Duo processor, if only one thread is using the second-level cache and / or bus, then it is expected to get the maximum benefit of the cache and bus systems because the other core does not interfere with the progress of the first thread. However, if two threads use the second-level cache concurrently, there may be performance degradation if one of the following conditions is true:

- Their combined working set is greater than the second-level cache size.
- Their combined bus usage is greater than the capacity of the bus.
- They both have extensive access to the same set in the second-level cache, and at least one of the threads writes to this cache line.

To avoid these pitfalls, multithreading software should try to investigate parallelism schemes in which only one of the threads access the second-level cache at a time, or where the second-level cache and the bus usage does not exceed their limits.

11.5.3 Avoid Excessive Software Prefetches

Pentium 4 and Intel Xeon Processors have an automatic hardware prefetcher. It can bring data and instructions into the unified second-level cache based on prior reference patterns. In most situations, the hardware prefetcher is likely to reduce system memory latency without explicit intervention from soft-

ware prefetches. It is also preferable to adjust data access patterns in the code to take advantage of the characteristics of the automatic hardware prefetcher to improve locality or mask memory latency. Processors based on Intel Core microarchitecture also provides several advanced hardware prefetching mechanisms. Data access patterns that can take advantage of earlier generations of hardware prefetch mechanism generally can take advantage of more recent hardware prefetch implementations.

Using software prefetch instructions excessively or indiscriminately will inevitably cause performance penalties. This is because excessively or indiscriminately using software prefetch instructions wastes the command and data bandwidth of the system bus.

Using software prefetches delays the hardware prefetcher from starting to fetch data needed by the processor core. It also consumes critical execution resources and can result in stalled execution. In some cases, it may be fruitful to evaluate the reduction or removal of software prefetches to migrate towards more effective use of hardware prefetch mechanisms. The guidelines for using software prefetch instructions are described in Chapter 3. The techniques for using automatic hardware prefetcher is discussed in Chapter 9.

User/Source Coding Rule 21. (M impact, L generality) *Avoid excessive use of software prefetch instructions and allow automatic hardware prefetcher to work. Excessive use of software prefetches can significantly and unnecessarily increase bus utilization if used inappropriately.*

11.5.4 Improve Effective Latency of Cache Misses

System memory access latency due to cache misses is affected by bus traffic. This is because bus read requests must be arbitrated along with other requests for bus transactions. Reducing the number of outstanding bus transactions helps improve effective memory access latency.

One technique to improve effective latency of memory read transactions is to use multiple overlapping bus reads to reduce the latency of sparse reads. In situations where there is little locality of data or when memory reads need to be arbitrated with other bus transactions, the effective latency of scattered memory reads can be improved by issuing multiple memory reads back-to-back to overlap multiple outstanding memory read transactions. The average latency of back-to-back bus reads is likely to be lower than the average latency of scattered reads interspersed with other bus transactions. This is because only the first memory read needs to wait for the full delay of a cache miss.

User/Source Coding Rule 22. (M impact, M generality) *Consider using overlapping multiple back-to-back memory reads to improve effective cache miss latencies.*

Another technique to reduce effective memory latency is possible if one can adjust the data access pattern such that the access strides causing successive cache misses in the last-level cache is predominantly less than the trigger threshold distance of the automatic hardware prefetcher. See Section 9.5.3, "Example of Effective Latency Reduction with Hardware Prefetch."

User/Source Coding Rule 23. (M impact, M generality) *Consider adjusting the sequencing of memory references such that the distribution of distances of successive cache misses of the last level cache peaks towards 64 bytes.*

11.5.5 Use Full Write Transactions to Achieve Higher Data Rate

Write transactions across the bus can result in write to physical memory either using the full line size of 64 bytes or less than the full line size. The latter is referred to as a partial write. Typically, writes to write-back (WB) memory addresses are full-size and writes to write-combine (WC) or uncacheable (UC) type memory addresses result in partial writes. Both cached WB store operations and WC store operations utilize a set of six WC buffers (64 bytes wide) to manage the traffic of write transactions. When competing traffic closes a WC buffer before all writes to the buffer are finished, this results in a series of 8-byte partial bus transactions rather than a single 64-byte write transaction.

User/Source Coding Rule 24. (M impact, M generality) *Use full write transactions to achieve higher data throughput.*

Frequently, multiple partial writes to WC memory can be combined into full-sized writes using a software write-combining technique to separate WC store operations from competing with WB store traffic. To implement software write-combining, uncacheable writes to memory with the WC attribute are written to

a small, temporary buffer (WB type) that fits in the first level data cache. When the temporary buffer is full, the application copies the content of the temporary buffer to the final WC destination.

When partial-writes are transacted on the bus, the effective data rate to system memory is reduced to only 1/8 of the system bus bandwidth.

11.6 MEMORY OPTIMIZATION

Efficient operation of caches is a critical aspect of memory optimization. Efficient operation of caches needs to address the following:

- Cache blocking.
- Shared memory optimization.
- Eliminating 64-KByte aliased data accesses.
- Preventing excessive evictions in first-level cache.

11.6.1 Cache Blocking Technique

Loop blocking is useful for reducing cache misses and improving memory access performance. The selection of a suitable block size is critical when applying the loop blocking technique. Loop blocking is applicable to single-threaded applications as well as to multithreaded applications running on processors with or without HT Technology. The technique transforms the memory access pattern into blocks that efficiently fit in the target cache size.

When targeting Intel processors supporting HT Technology, the loop blocking technique for a unified cache can select a block size that is no more than one half of the target cache size, if there are two logical processors sharing that cache. The upper limit of the block size for loop blocking should be determined by dividing the target cache size by the number of logical processors available in a physical processor package. Typically, some cache lines are needed to access data that are not part of the source or destination buffers used in cache blocking, so the block size can be chosen between one quarter to one half of the target cache (see Chapter 3, “General Optimization Guidelines”).

Software can use the deterministic cache parameter leaf of CPUID to discover which subset of logical processors are sharing a given cache (see Chapter 9, “Optimizing Cache Usage”). Therefore, guideline above can be extended to allow all the logical processors serviced by a given cache to use the cache simultaneously, by placing an upper limit of the block size as the total size of the cache divided by the number of logical processors serviced by that cache. This technique can also be applied to single-threaded applications that will be used as part of a multitasking workload.

User/Source Coding Rule 25. (H impact, H generality) Use cache blocking to improve locality of data access. Target one quarter to one half of the cache size when targeting Intel processors supporting HT Technology or target a block size that allow all the logical processors serviced by a cache to share that cache simultaneously.

11.6.2 Shared-Memory Optimization

Maintaining cache coherency between discrete processors frequently involves moving data across a bus that operates at a clock rate substantially slower than the processor frequency.

11.6.2.1 Minimize Sharing of Data between Physical Processors

When two threads are executing on two physical processors and sharing data, reading from or writing to shared data usually involves several bus transactions (including snooping, request for ownership changes, and sometimes fetching data across the bus). A thread accessing a large amount of shared memory is likely to have poor processor-scaling performance.

User/Source Coding Rule 26. (H impact, M generality) Minimize the sharing of data between threads that execute on different bus agents sharing a common bus. The situation of a platform consisting of multiple bus domains should also minimize data sharing across bus domains.

One technique to minimize sharing of data is to copy data to local stack variables if it is to be accessed repeatedly over an extended period. If necessary, results from multiple threads can be combined later by writing them back to a shared memory location. This approach can also minimize time spent to synchronize access to shared data.

11.6.2.2 Batched Producer-Consumer Model

The key benefit of a threaded producer-consumer design, shown in Figure 11-5, is to minimize bus traffic while sharing data between the producer and the consumer using a shared second-level cache. On an Intel Core Duo processor and when the work buffers are small enough to fit within the first-level cache, re-ordering of producer and consumer tasks are necessary to achieve optimal performance. This is because fetching data from L2 to L1 is much faster than having a cache line in one core invalidated and fetched from the bus.

Figure 11-5 illustrates a batched producer-consumer model that can be used to overcome the drawback of using small work buffers in a standard producer-consumer model. In a batched producer-consumer model, each scheduling quanta batches two or more producer tasks, each producer working on a designated buffer. The number of tasks to batch is determined by the criteria that the total working set be greater than the first-level cache but smaller than the second-level cache.

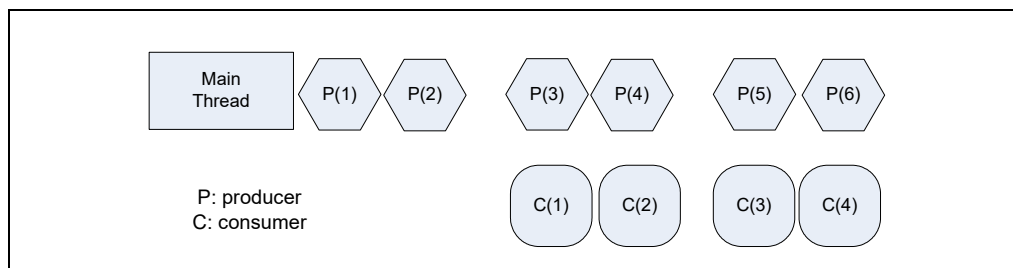

Figure 11-5. Batched Approach of Producer Consumer Model

Example 11-8 shows the batched implementation of the producer and consumer thread functions.

Example 11-8. Batched Implementation of the Producer Consumer Threads

```
void producer_thread()
{
    int iter_num = workamount - batchsize;
    int mode1;
    for (mode1=0; mode1 < batchsize; mode1++)
    {
        produce(bufs[mode1],count); }

    while (iter_num--)
    {
        Signal(&signal1,1);
        produce(bufs[mode1],count); // placeholder function
        WaitForSignal(&end1);
        mode1++;
        if (mode1 > batchsize)
            mode1 = 0;
    }
}
```

Example 11-8. Batched Implementation of the Producer Consumer Threads (Contd.)

```

void consumer_thread()
{
    int mode2 = 0;
    int iter_num = workamount - batchsize;
    while (iter_num--)
    {
        WaitForSignal(&signal1);
        consume(buffs[mode2],count); // placeholder function
        Signal(&end1,1);
        mode2++;
        if (mode2 > batchsize)
            mode2 = 0;
    }
    for (i=0;i<batchsize;i++)
    {
        consume(buffs[mode2],count);
        mode2++;
        if (mode2 > batchsize)
            mode2 = 0;
    }
}

```

11.6.3 Eliminate 64-KByte Aliased Data Accesses

The 64-KByte aliasing condition is discussed in Chapter 3. Memory accesses that satisfy the 64-KByte aliasing condition can cause excessive evictions of the first-level data cache. Eliminating 64-KByte aliased data accesses originating from each thread helps improve frequency scaling in general. Furthermore, it enables the first-level data cache to perform efficiently when HT Technology is fully utilized by software applications.

User/Source Coding Rule 27. (H impact, H generality) *Minimize data access patterns that are offset by multiples of 64 KBytes in each thread.*

The presence of 64-KByte aliased data access can be detected using Pentium 4 processor performance monitoring events. Appendix B includes an updated list of Pentium 4 processor performance metrics. These metrics are based on events accessed using the Intel VTune Performance Analyzer.

Performance penalties associated with 64-KByte aliasing are applicable mainly to current processor implementations of HT Technology or Intel NetBurst microarchitecture. The next section discusses memory optimization techniques that are applicable to multithreaded applications running on processors supporting HT Technology.

11.7 FRONT END OPTIMIZATION

For dual-core processors where the second-level unified cache is shared by two processor cores (Intel Core Duo processor and processors based on Intel Core microarchitecture), multi-threaded software should consider the increase in code working set due to two threads fetching code from the unified cache as part of front end and cache optimization. For quad-core processors based on Intel Core microarchitecture, the considerations that applies to Intel Core 2 Duo processors also apply to quad-core processors.

11.7.1 Avoid Excessive Loop Unrolling

Unrolling loops can reduce the number of branches and improve the branch predictability of application code. Loop unrolling is discussed in detail in Chapter 3. Loop unrolling must be used judiciously. Be sure to consider the benefit of improved branch predictability and the cost of under-utilization of the loop stream detector (LSD).

User/Source Coding Rule 28. (M impact, L generality) Avoid excessive loop unrolling to ensure the LSD is operating efficiently.

11.8 AFFINITIES AND MANAGING SHARED PLATFORM RESOURCES

Modern Oses provide either API and/or data constructs (e.g. affinity masks) that allow applications to manage certain shared resources , e.g. logical processors, Non-Uniform Memory Access (NUMA) memory sub-systems.

Before multithreaded software considers using affinity APIs, it should consider the recommendations in Table 11-2.

Table 11-2. Design-Time Resource Management Choices

Runtime Environment	Thread Scheduling/Processor Affinity Consideration	Memory Affinity Consideration
A single-threaded application	Support OS scheduler objectives on system response and throughput by letting OS scheduler manage scheduling. OS provides facilities for end user to optimize runtime specific environment.	Not relevant; let OS do its job.
A multi-threaded application requiring: i) less than all processor resource in the system, ii) share system resource with other concurrent applications, iii) other concurrent applications may have higher priority.	Rely on OS default scheduler policy. Hard-coded affinity-binding will likely harm system response and throughput; and/or in some cases hurting application performance.	Rely on OS default scheduler policy. Use API that could provide transparent NUMA benefit without managing NUMA explicitly.
A multi-threaded application requiring i) foreground and higher priority, ii) uses less than all processor resource in the system, iii) share system resource with other concurrent applications, iv) but other concurrent applications have lower priority.	If application-customized thread binding policy is considered, a cooperative approach with OS scheduler should be taken instead of hard-coded thread affinity binding policy. For example, the use of SetThreadIdealProcessor() can provide a floating base to anchor a next-free-core binding policy for locality-optimized application binding policy, and cooperate with default OS policy.	Use API that could provide transparent NUMA benefit without managing NUMA explicitly. Use performance event to diagnose non-local memory access issue if default OS policy cause performance issue.

Table 11-2. Design-Time Resource Management Choices (Contd.)

Runtime Environment	Thread Scheduling/Processor Affinity Consideration	Memory Affinity Consideration
<p>A multi-threaded application runs in foreground, requiring all processor resource in the system and not sharing system resource with concurrent applications; MPI-based multi-threading.</p>	<p>Application-customized thread binding policy can be more efficient than default OS policy. Use performance event to help optimize locality and cache transfer opportunities.</p> <p>A multi-threaded application that employs its own explicit thread affinity-binding policy should deploy with some form of opt-in choice granted by the end-user or administrator. For example, permission to deploy explicit thread affinity-binding policy can be activated after permission is granted after installation.</p>	<p>Application-customized memory affinity binding policy can be more efficient than default OS policy. Use performance event to diagnose non-local memory access issues related to either OS or custom policy</p>

11.8.1 Topology Enumeration of Shared Resources

Whether multithreaded software ride on OS scheduling policy or need to use affinity APIs for customized resource management, understanding the topology of the shared platform resource is essential. The processor topology of logical processors (SMT), processor cores, and physical processors in the platform can be enumerated using information provided by CPUID. This is discussed in Chapter 9, “Multiple-Processor Management” of Intel® 64 and IA-32 Architectures Software Developer’s Manual, Volume 3A. A white paper and reference code is also available from Intel.

11.8.2 Non-Uniform Memory Access

Platforms using two or more Intel Xeon processors based on Nehalem microarchitecture support non-uniform memory access (NUMA) topology because each physical processor provides its own local memory controller. NUMA offers system memory bandwidth that can scale with the number of physical processors. System memory latency will exhibit asymmetric behavior depending on the memory transaction occurring locally in the same socket or remotely from another socket. Additionally, OS-specific construct and/or implementation behavior may present additional complexity at the API level that the multi-threaded software may need to pay attention to memory allocation/initialization in a NUMA environment.

Generally, latency sensitive workload would favor memory traffic to stay local over remote. If multiple threads share a buffer, the programmer will need to pay attention to OS-specific behavior of memory allocation/initialization on a NUMA system.

Bandwidth sensitive workloads will find it convenient to employ a data composition threading model and aggregate application threads executing in each socket to favor local traffic on a per-socket basis to achieve overall bandwidth scalable with the number of physical processors.

The OS construct that provides the programming interface to manage local/remote NUMA traffic is referred to as memory affinity. Because OS manages the mapping between physical address (populated by system RAM) to linear address (accessed by application software); and paging allows dynamic reassignment of a physical page to map to different linear address dynamically, proper use of memory affinity will require a great deal of OS-specific knowledge.

To simplify application programming, OS may implement certain APIs and physical/linear address mapping to take advantage of NUMA characteristics transparently in certain situations. One common technique is for OS to delay commit of physical memory page assignment until the first memory reference on that physical page is accessed in the linear address space by an application thread. This means that the allocation of a memory buffer in the linear address space by an application thread does not

necessarily determine which socket will service local memory traffic when the memory allocation API returns to the program. However, the memory allocation API that supports this level of NUMA transparency varies across different OSes. For example, the portable C-language API “malloc” provides some degree of transparency on Linux*, whereas the API “VirtualAlloc” behave similarly on Windows*. Different OSes may also provide memory allocation APIs that require explicit NUMA information, such that the mapping between linear address to local/remote memory traffic are fixed at allocation.

Example 11-9 shows an example that multi-threaded application could undertake the least amount of effort dealing with OS-specific APIs and to take advantage of NUMA hardware capability. This parallel approach to memory buffer initialization is conducive to having each worker thread keep memory traffic local on NUMA systems.

Example 11-9. Parallel Memory Initialization Technique Using OpenMP and NUMA

```
#ifndef _LINUX // Linux implements malloc to commit physical page at first touch/access
    buf1 = (char *) malloc(DIM*(sizeof (double))+1024);
    buf2 = (char *) malloc(DIM*(sizeof (double))+1024);
    buf3 = (char *) malloc(DIM*(sizeof (double))+1024);
#endif
#ifdef windows
// Windows implements malloc to commit physical page at allocation, so use VirtualAlloc
    buf1 = (char *) VirtualAlloc(NULL, DIM*(sizeof (double))+1024, fAllocType, fProtect);
    buf2 = (char *) VirtualAlloc(NULL, DIM*(sizeof (double))+1024, fAllocType, fProtect);
    buf3 = (char *) VirtualAlloc(NULL, DIM*(sizeof (double))+1024, fAllocType, fProtect);
#endif
    (continue)

    a = (double *) buf1;
    b = (double *) buf2;
    c = (double *) buf3;
#pragma omp parallel
{ // use OpenMP threads to execute each iteration of the loop
// number of OpenMP threads can be specified by default or via environment variable
#pragma omp for private(num)
// each loop iteration is dispatched to execute in different OpenMP threads using private iterator
    for(num=0;num<len;num++)
        { // each thread perform first-touches to its own subset of memory address, physical pages
//            mapped to the local memory controller of the respective threads
                a[num]=10.;
                b[num]=10.;
                c[num]=10.;
        }
}
}
```

Note that the example shown in Example 11-9 implies that the memory buffers will be freed after the worker threads created by OpenMP have ended. This situation avoids a potential issue of repeated use of malloc/free across different application threads. Because if the local memory that was initialized by one thread and subsequently got freed up by another thread, the OS may have difficulty in tracking/re-allocating memory pools in linear address space relative to NUMA topology. In Linux, another API, “numa_local_alloc” may be used.

11.9 OPTIMIZATION OF OTHER SHARED RESOURCES

Resource optimization in multi-threaded application depends on the cache topology and execution resources associated within the hierarchy of processor topology. Processor topology and an algorithm for software to identify the processor topology are discussed in Chapter 9, “Multiple-Processor Management” of the Intel® 64 and IA-32 Architectures Software Developer’s Manual, Volume 3A.

In platforms with shared buses, the bus system is shared by multiple agents at the SMT level and at the processor core level of the processor topology. Thus multi-threaded application design should start with an approach to manage the bus bandwidth available to multiple processor agents sharing the same bus link in an equitable manner. This can be done by improving the data locality of an individual application thread or allowing two threads to take advantage of a shared second-level cache (where such shared cache topology is available).

In general, optimizing the building blocks of a multi-threaded application can start from an individual thread. The guidelines discussed in Chapter 3 through Chapter 13 largely apply to multi-threaded optimization.

Tuning Suggestion 2. *Optimize single threaded code to maximize execution throughput first.*

Tuning Suggestion 3. *Employ efficient threading model, leverage available tools (such as Intel Threading Building Block, Intel Thread Checker, Intel Thread Profiler) to achieve optimal processor scaling with respect to the number of physical processors or processor cores.*

11.9.1 Expanded Opportunity for HT Optimization

The Hyper-Threading Technology (HT) implementation in Nehalem microarchitecture differs from previous generations of HT implementations. It offers broader opportunity for multi-threaded software to take advantage of HT and achieve higher system throughput over a broader range of application problems. This section provides a few heuristic recommendations and illustrates some of these optimization opportunities.

Chapter 2, “Intel® 64 and IA-32 Architectures” covered some of the microarchitectural capability enhancements in Hyper-Threading Technology. Many of these enhancements center around the basic needs of multi-threaded software in terms of sharing common hardware resources that may be used by more than one thread context.

Different software algorithms and workload characteristics may produce different performance characteristics due to their demands on critical microarchitectural resources that may be shared amongst several logical processors. A brief comparison of the various microarchitectural subsystems that can play a significant role in software tuning for HT is summarized in Table 11-3.

Table 11-3. Microarchitectural Resources Comparisons of HT Implementations

Microarchitectural Subsystem	Nehalem Microarchitecture 06_1AH	Intel NetBurst Microarchitecture 0F_02H, 0F_03H, 0F_04H, 0F_06H
Issue ports, execution units	Three issue ports (0, 1, 5) distributed to handle ALU, SIMD, and FP computations.	Unbalanced ports, fast ALU SIMD and FP sharing the same port (port 1).
Buffering	More entries in ROB, RS, fill buffers, etc., with moderate pipeline depths.	Less balance between buffer entries and pipeline depths.
Branch Prediction and Misaligned memory access	More robust speculative execution with immediate reclamation after misprediction; efficient handling of cache splits.	More microarchitectural hazards resulting in pipeline cleared for both threads.

Table 11-3. Microarchitectural Resources Comparisons of HT Implementations

Microarchitectural Subsystem	Nehalem Microarchitecture 06_1AH	Intel NetBurst Microarchitecture 0F_02H, 0F_03H, 0F_04H, 0F_06H
Cache hierarchy	Larger and more efficient.	More microarchitectural hazards to work around.
Memory and bandwidth	NUMA, three channels per socket to DDR3, up to 32GB/s per socket.	SMP, FSB, or dual FSB, up to 12.8 GB/s per FSB.

For compute bound workloads, the HT opportunity in Intel NetBurst microarchitecture tends to favor thread contexts that executes with relatively high CPI (average cycles to retire consecutive instructions). At a hardware level, this is in part due to the issue port imbalance in the microarchitecture, as port 1 is shared by fast ALU, slow ALU (more heavy-duty integer operations), SIMD, and FP computations. At a software level, some of the cause for high CPI and may appear as benign catalyst for providing HT benefit may include: long latency instructions (port 1), some L2 hits, occasional branch mispredictions, etc. But the length of the pipeline in Intel NetBurst microarchitecture often impose additional internal hardware constraints that limits software's ability to take advantage of HT.

The microarchitectural enhancements listed in Table 11-3 are expected to provide broader software optimization opportunities for compute-bound workloads. Whereas contention in the same execution unit by two compute-bound threads might be a concern to choose a functional-decomposition threading model over data-composition threading. Nehalem microarchitecture will likely be more accommodating to support the programmer to choose the optimal threading decomposition models.

Memory intensive workloads can exhibit a wide range of performance characteristics, ranging from completely parallel memory traffic (saturating system memory bandwidth, as in the well-known example of Stream), memory traffic dominated by memory latency, or various mixtures of compute operations and memory traffic of either kind.

The HT implementation in Intel NetBurst microarchitecture may provide benefit to some of the latter two types of workload characteristics. The HT capability in the Nehalem microarchitecture can broaden the operating envelop of the two latter types of workload characteristics to deliver higher system throughput, due to its support for non-uniform memory access (NUMA), more efficient link protocol, and system memory bandwidth that scales with the number of physical processors.

Some cache levels of the cache hierarchy may be shared by multiple logical processors. Using the cache hierarchy is an important means for software to improve the efficiency of memory traffic and avoid saturating the system memory bandwidth. Multi-threaded applications employing cache-blocking technique may wish to partition a target cache level to take advantage of Hyper-Threading Technology. Alternately two logical processors sharing the same L1 and L2, or logical processors sharing the L3 may wish to manage the shared resources according to their relative topological relationship. A white paper on processor topology enumeration and cache topology enumeration with companion reference code has been published (see reference at the end of Chapter 1).

The Intel® Xeon® Scalable Performance processor family based on the Cascade Lake product introduces support for Intel® Optane™ DC Persistent Memory Modules. These Intel Optane DC Persistent Memory Modules are larger in size compared to DRAM and are persistent, i.e., the content is maintained even when the system is powered down. However, latency is higher and bandwidth is lower than DRAM DIMMs.

12.1 MEMORY MODE AND APP-DIRECT MODE

Intel Optane DC Persistent Memory Module DIMMs can be used in two different modes.

12.1.1 Memory Mode

In memory mode, the memory is exposed as volatile memory. This is transparent to the operating system and applications. In particular, software can benefit, without modifications, from large memory capacity. The DRAM memory present in the system is being used as a memory-side cache. The intent behind this is for software to get the latency of the DRAM tier, while holding “in-memory” data that is the capacity of the Intel Optane DC Persistent Memory Module tier.

In memory mode, data on Intel Optane DC Persistent Memory Modules becomes inaccessible after a reboot. Since the media itself is non-volatile, this is implemented by encrypting the data with a key that is discarded during a power-cycle. The DRAM memory that is present on the socket is used as a directly-mapped cache for the Intel Optane DC Persistent Memory Modules. This implies that, in contrast to processor caches, there is no LRU policy for the cache. A cache line on Intel Optane DC Persistent Memory Modules will always evict the same cache line from DRAM. Operating systems can optimize for memory mode by using pages whose addresses do not conflict with pages that hold data that should not be evicted from the DRAM cache. For example, it is usually beneficial to always keep page tables in DRAM. The size of the working set greatly determines performance. If the working set of an application fits in DRAM, performance is not impacted as much by the latency and bandwidth of Intel Optane DC Persistent Memory Modules.

12.1.2 App Direct Mode

In app direct mode, the memory is exposed as a device, which can be formatted with a file system. One option is to use the Intel Optane DC Persistent Memory Module as a very fast block device, with a file system, called “storage over app direct”. This has the advantage that applications that are I/O bound benefit from the Intel Optane DC Persistent Memory Module without modifications to the software. In other words, we are using app direct for getting a fast storage device, but not using it as persistent memory. In contrast with this usage, rewriting the application for usage as persistent memory has several key benefits. The key difference from usage as “storage over app direct” is that data can be accessed on a cache line granularity. In order to load or store data on the device, the processor load and store instructions are used and no OS interaction is needed, once a page is allocated to a process. Thus app direct mode implements persistent memory. The operating system does not access persistent memory as RAM, but rather through a file system mounted with a special flag called “dax”. This usage of “dax” is what differentiates “app direct mode” (mount with dax) from “storage over app direct mode” (mount without dax). Mounting with dax provides the following advantages.

Once the persistent memory is mapped to the virtual address space of the application, reads and writes can be done using load and store instructions, and this has the following advantages over storage over app direct:

- This completely avoids the system call.

- Instead of transferring a complete page (e.g. 4KB), only a cache line is transferred (64B).
- Only one copy of the data is needed as memory is not copied back and forth between persistent memory and DRAM.
- Access is synchronous.

Note that the memory the operating system and conventional OS memory reporting tools report only the DRAM that is present in the system, since persistent memory is accessible via a file system. The two pools of memory are distinct from one another, and one of the key differentiators of app direct mode is that software has full control over which data is located in DRAM vs. NVDIMM. For optimal performance, software can therefore place latency-sensitive data structures in DRAM, either by generating a copy or reconstructing it. Examples are index data structures, which are typically accessed randomly but can be reconstructed after a restart.

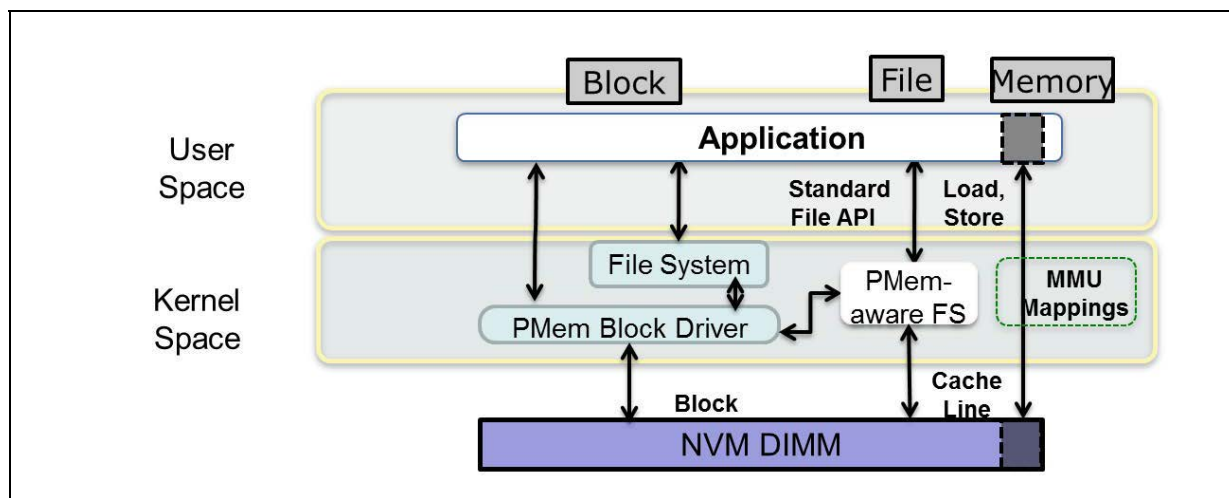

Figure 12-1. In App Direct Mode, Data on the Intel® Optane™ DC Persistent Memory Module is Accessed Directly with Loads and Stores

12.1.3 Selecting a Mode

The software developer needs to consider various factors while determining which mode may be best suited for a given application and usage scenario.

- Is there a benefit from large memory capacity (larger than what is possible with DRAM on a given platform)? For example, an application may be paging heavily to disk, and may be able to page less with larger memory capacity. Other examples may be an application choosing a different algorithm when given larger memory capacity, which may result in better performance, and an application choosing to store and re-use intermediate results when given larger capacity.
- Is there a benefit from using persistence in the memory sub-system? This may include faster startup times (avoid loading data from disk to memory, and/or avoid re-building “in-memory” pointer-based structures like linked lists or trees on restart. This may also include benefits from a faster path to durability. For example, memory could be the final, durable destination for data instead of disk. Applications that are bound by disk latency or bandwidth can benefit from using memory for durability.
- What is the sensitivity of the application to memory latency? Intel Optane DC Persistent Memory Module latencies are higher than DRAM, typically around 3-4 times the latency of DRAM. In the cases where an Intel Optane DC Persistent Memory Module is replacing memory, a lot depends on how predictable those accesses are, and also how sensitive those memory accesses are to latency. To illustrate these cases, let’s first consider the scenario where the application is reading a sequential array of numbers that is several GB in size from an Intel Optane DC Persistent Memory Module. In this case, since the accesses are spatially predictable, they are prefetchable by hardware and software prefetchers. As a result, the data can always be in the processor caches before the

application requests the data, and the latency of the Intel Optane DC Persistent Memory Module is not seen by the application. On the other hand, if the application was walking a linked list for example, it is not possible to identify the next node in the linked list without first reading the current node (this is called “pointer chasing”). In this case, the latency of the Intel Optane DC Persistent Memory Module is seen by the application. Another important consideration mentioned above is the sensitivity of the application to memory latency. In some cases, the application is such that the processor cores can do other useful work while waiting for memory references to the Intel Optane DC Persistent Memory Module to return; since useful work is being done, performance is often not significantly impacted. In other cases, the cores are stalled while waiting for memory references from the Intel Optane DC Persistent Memory Module, and this can often impact performance.

If the application as a whole is indeed sensitive to memory latency, this then warrants an examination of which memory data structures are sensitive. A good use for the Intel Optane DC Persistent Memory Module is large capacity data structures that are not as sensitive to memory latency based on the considerations outlines above. Smaller data structures that are heavily accessed and/or are sensitive to memory latency are better suited to DRAM.

The chart below shows a pictorial flow based on the above considerations.

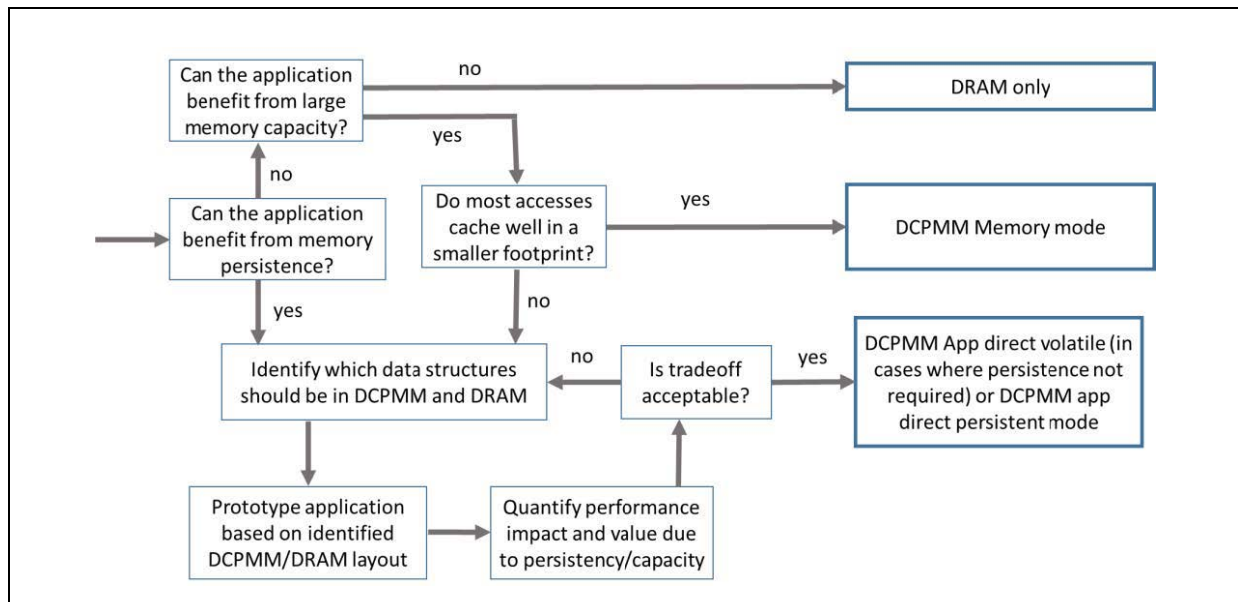

Figure 12-2. Decision Flow for Determining When to Use Intel® Optane™ DC Persistent Memory Module vs. DRAM

12.2 DEVICE CHARACTERISTICS OF INTEL® OPTANE™ DC PERSISTENT MEMORY MODULE

In the previous section, one of the considerations for software developers to select the Intel Optane DC Persistent Memory Module for a data structure was “performance sensitivity to memory latency”. In this section, we provide various considerations that determine this sensitivity; these include different device characteristics from DRAM, additional code changes required for new features like persistence in memory, etc.

12.2.1 Intel® Optane™ DC Persistent Memory Module Latency

Intel Optane DC Persistent Memory Module devices have different access characteristics from DRAM since they are made of a different material than DRAM. The table below summarizes read latencies for sequential and random accesses respectively.

Table 12-1. Latencies for Accessing Intel® Optane™ DC Persistent Memory Modules

Latency	Intel® Optane™ DC Persistent Memory Module	DRAM
Idle sequential read latency	~170ns	~75ns
Idle random read latency	~320ns	~80ns

In the case of DRAM, the difference between sequential and random latencies is limited to a few nanoseconds; this is due to sequential accesses resulting in greater hits in DRAM row buffers. However in the case of Intel Optane DC Persistent Memory Modules, not only do the latencies differ overall from DRAM, they also differ significantly between the sequential and random access cases.

The difference in access latency of Intel Optane DC Persistent Memory Modules from DRAM requires special consideration for software developers from a performance perspective. See Chapter 9, “Optimizing Cache Usage” for general guidelines on optimizing processor cache usage.

In memory mode, it is expected that the DRAM cache would absorb most of the accesses, and the application would see DRAM-like latencies. Note that the latency to access Intel Optane DC Persistent Memory Modules in memory mode is ~30-40 ns higher than in app direct mode, due to the overhead of first looking up the DRAM cache. Performance in memory mode can be improved with traditional cache tiling and locality optimization techniques that keep the working set within the size of the DRAM cache.

Further, each Intel Optane DC Persistent Memory Module features some form of buffering at 256 Byte granularity, and this is one of the units at which we distinguish between sequential and random accesses. It is therefore beneficial to collocate data inside 256 Bytes and read them together to get sequential access latencies as opposed to random, a consideration for software data structure design.

12.2.2 Read vs. Write Bandwidth

The different access characteristics of Intel Optane DC Persistent Memory Modules include different read and write bandwidths compared to DRAM, as illustrated in the table below.

Table 12-2. Bandwidths per DIMM for Intel® Optane™ DC Persistent Memory Modules and DRAM

Per DIMM Bandwidths	Intel® Optane™ DC Persistent Memory Module	DRAM
Sequential read	~7.6 GB/s	~15 GB/s
Random read	~2.4 GB/s	~15 GB/s
Sequential write	~2.3 GB/s	~15 GB/s
Random write	~0.5 GB/s	~15 GB/s

From the above table, we can make the following observations.

1. Reads and writes are asymmetrical, and more specifically read bandwidths are higher than write bandwidths. This is an important consideration for software design, and should be factored in decisions. For example, a data structure with random writes and high write amplification would not be a good choice for Intel Optane DC Persistent Memory Modules.
2. Sequential and random access characteristics are also markedly different. This is again a consideration for choice of data structure design and placement in Intel Optane DC Persistent Memory Modules compared with DRAM, with emphasis on the locality within 256B granularity to get the benefits of sequential access placements.

It is important to note that bandwidth is a first class constraint in usage of these DIMMs and it is important to avoid operating at bandwidths close to the capability of the DIMM, as illustrated with the red circles in Figure 12-3.

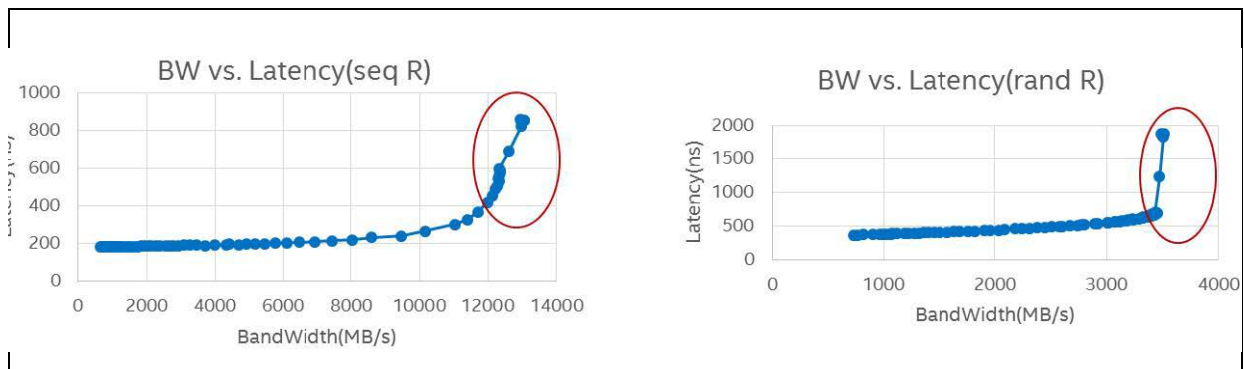

Figure 12-3. Loaded Latency Curves for One Intel® Optane™ DC Persistent Memory Module DIMM: Sequential Traffic (Left) and Random Traffic (Right)

When memory bandwidth is close to being saturated, the latencies tend to be very high and hurt application performance. The bandwidth demand is typically a function of the number of cores driving memory accesses, and the nature of the accesses, i.e., sequential vs. random access pattern as well as the read-write mix. On the other hand, the bandwidth capability of the platform is a function of the number of channels and DIMMs available. It is therefore important to balance the read and write traffic with the capabilities of the system, e.g., the number of threads reading and writing to the Intel Optane DC Persistent Memory Module vs. the number of populated memory channels.

While writing to Intel Optane DC Persistent Memory Module, since bandwidth is more limited than for DRAM, it is recommended to use non-temporal stores over regular stores in cases when it is not expected that the data written to will be re-used in the near future, or while writing to very large buffers. (See Section 9.4.1.2 for details).

12.2.3 Number of Threads for Optimal Bandwidth

As noted earlier, the Intel Optane DC Persistent Memory Module DIMM is buffering and combining data at 256B granularity. This can have implications on the number of threads that are accessing memory on the Intel Optane DC Persistent Memory Module. If there are too many threads attempting to write to the memory on the Intel Optane DC Persistent Memory Module concurrently, the benefits of write combining and 256B locality are lost if spatial locality is lost due to writes intercepting from other threads. As a result, even though each thread may write sequentially, the traffic begins to look random at the DIMM level, and therefore as the number of threads writing to the Intel Optane DC Persistent Memory Module crosses a threshold, one begins to observe random access bandwidths instead of sequential access bandwidths.

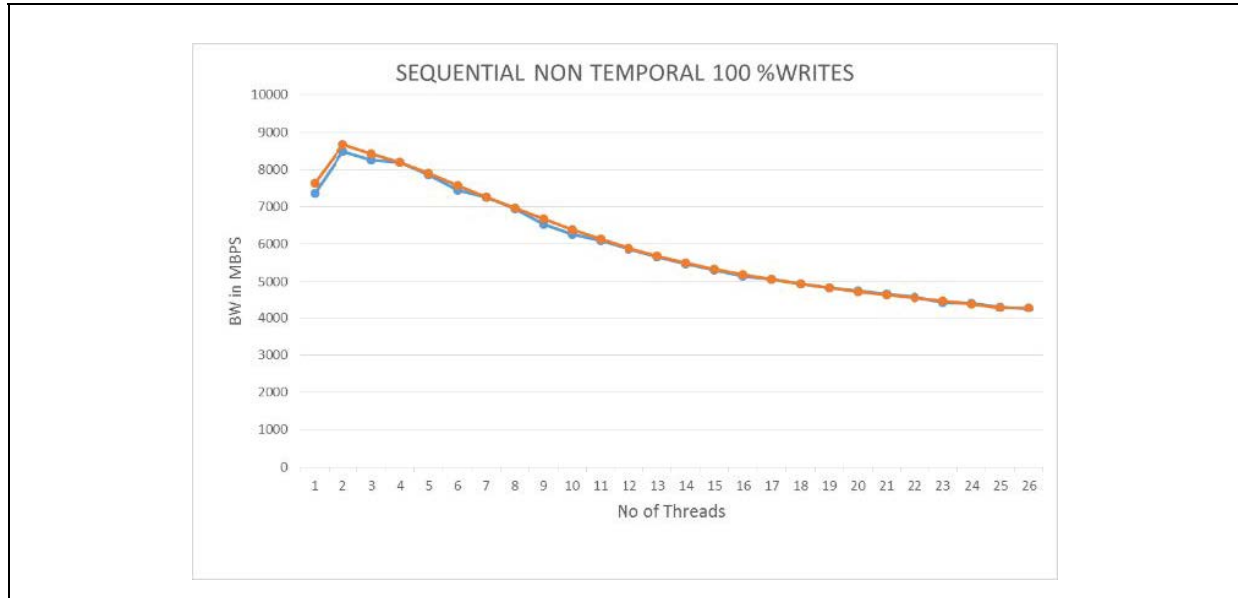

Figure 12-4. Number of Threads vs. Bandwidth¹

NOTES:

1. As the number of threads increases, the bandwidth first increases and then decreases. This decrease is due to the fact that even though the accesses are sequential in nature, as we have more and more threads injecting their accesses into the memory subsystem, the “sequentiality” (especially at the mentioned 256B granularity) is lost when observed from the standpoint of a finite buffer for write combining.

Figure 12-5, Figure 12-6, and Figure 12-7 illustrate the differences in combining at 256B locality and how this is impacted by the number of threads that are injecting references to the Intel Optane DC Persistent Memory Module. It is important to keep this 256B locality in mind while selecting data structures, and the concurrency of accesses to the Intel Optane DC Persistent Memory Module.

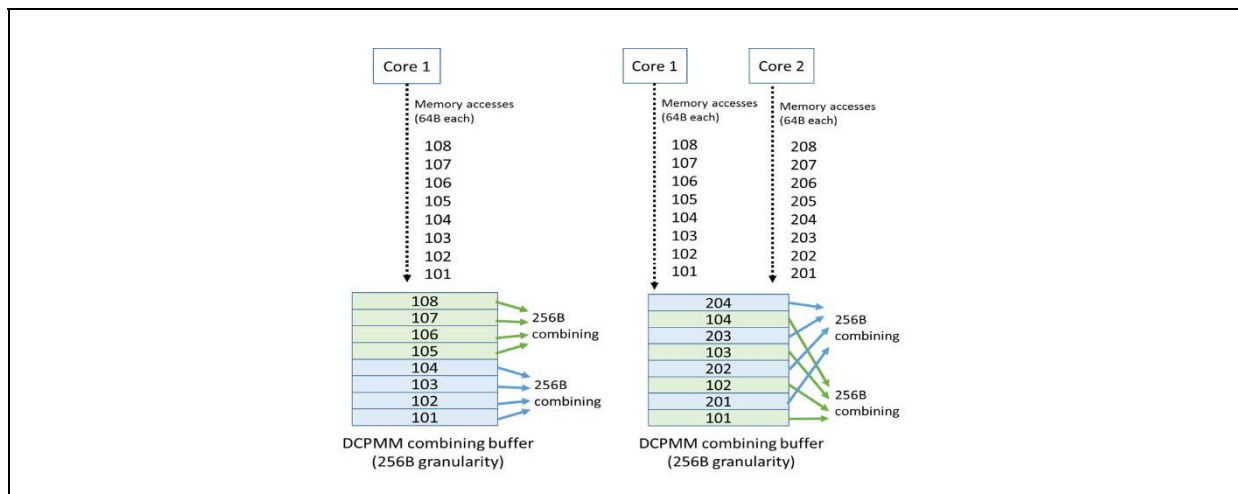

Figure 12-5. Combining with Two Cores¹

NOTES:

1. 101, 102, etc. refer to 64B accesses from a core 1, and likewise for the other core. It can be seen that for two cores, and a sample buffer size of 8 (note that this is strictly an example size for illustration purposes), there is 100% combining within the buffer at 256B granularity. This makes the accesses 100% sequential from the memory system standpoint.

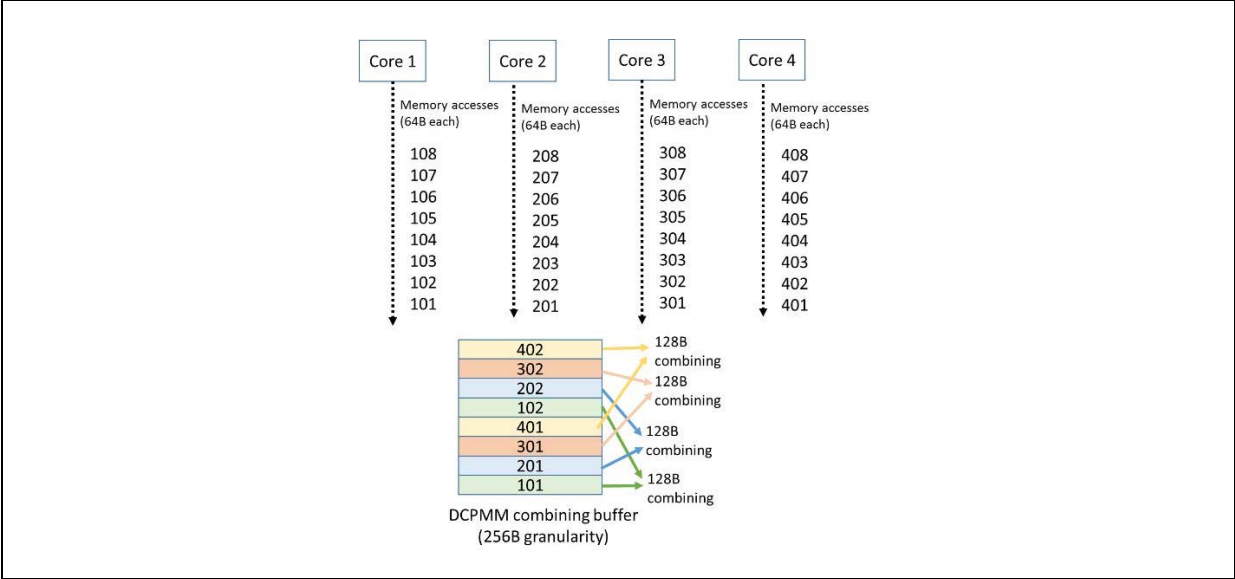

Figure 12-6. Combining with Four Cores¹

NOTES:

1. 101, 102, etc refer to 64B accesses from core 1, and likewise for the other cores. It can be seen that for four cores, and a sample buffer size of 8, there is 50% combining within the buffer at 256B granularity (only 128B combining is possible as the buffer gets full and needs to be drained for forward progress). This makes the accesses 50% sequential from the memory system standpoint.

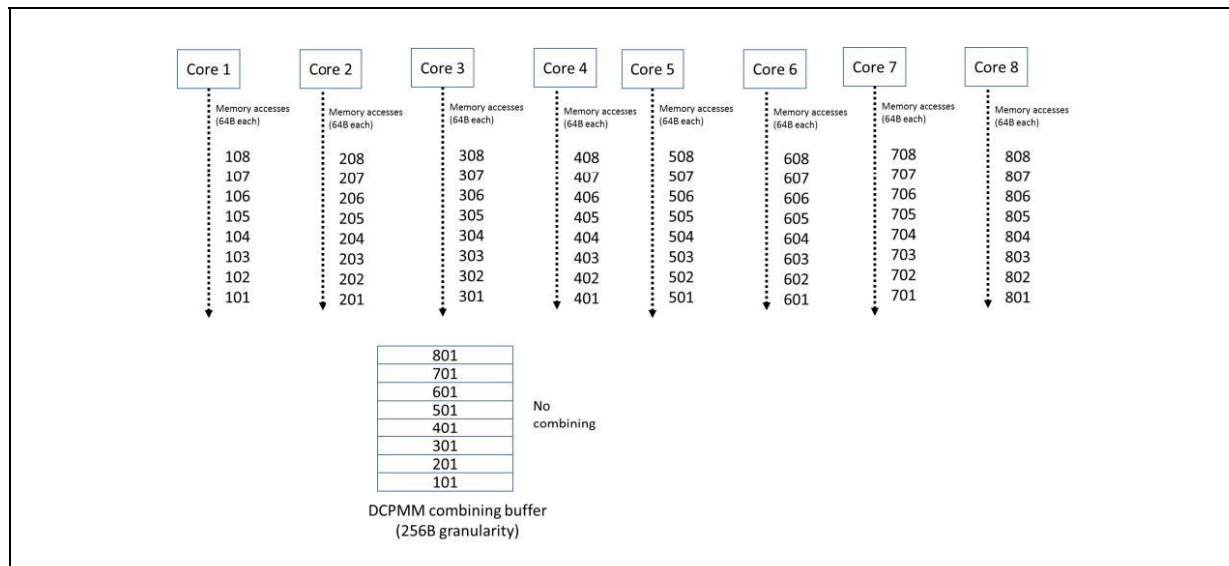

Figure 12-7. Combining with Eight Cores¹

NOTES:

1. For eight cores, there is no combining possible and the sequential references seem random from a memory system standpoint.

12.3 PLATFORM IMPLICATIONS OF HANDLING A SECOND TYPE OF MEMORY

12.3.1 Multi-Processor Cache Coherence

On systems with multiple processors, a directory is used for cache coherence. This directory is implemented as a distributed in-memory directory, with the coherence state of each cache line stored in metadata within the line itself in memory. This implementation improves over the pure snoop-based mechanisms where for each memory access, the processor always checks the other processors’ caches in order to know the coherence state of the line, i.e., if the line is present elsewhere, therefore increasing the latency of each access.

In directory based protocols, the directory tracks if the coherence state is changed. For example, a memory read from another processor is recorded in the metadata in memory. These directory updates result in write to memory (metadata) to record the change in coherence state. In cases where there are cores in different processors repeatedly reading the same set of lines in the Intel Optane DC Persistent Memory Module, there will be several writes to the Intel Optane DC Persistent Memory Module recording the change in the coherence state each time. These writes are called “directory writes” and tend to be random in nature. As a result, several of these writes can lower the effective Intel Optane DC Persistent Memory Module bandwidth that is available to the application. From a software standpoint, it is worthwhile to consider how the Intel Optane DC Persistent Memory Module may be accessed by different threads, and if these kind of patterns are observed, one option to consider is to change the coherence protocol for Intel Optane DC Persistent Memory Module regions from directory-based to snoop-based by disabling the directory system-wide.

12.3.2 Shared Queues in the Memory Hierarchy

In processors based on the Cascade Lake product, accesses to DRAM and Intel Optane DC Persistent Memory Modules are mostly independent of each other. However there are instances where both DRAM and memory in Intel Optane DC Persistent Memory Modules reference traverse common paths in the memory subsystem and impact each other. As an example, there are processor queues that are common between DRAM and Intel Optane DC Persistent Memory Modules. There is a QoS setting in the BIOS that helps arbitrate these queues. Likewise, DRAM and Intel Optane DC Persistent Memory Modules can share the same memory channel (although there are separate queues per channel, the channel itself is shared). There is a setting to control switching between these separate queues (switching at finer granularity optimizes for latency; switching at coarser granularity allows more bursts and optimizes for bandwidth). These settings are exposed as BIOS knobs; please refer to the BIOS optimization guide for further detail.

12.4 IMPLEMENTING PERSISTENCE FOR MEMORY

In app direct mode, when software is using persistence, software might want to explicitly control that memory stores have been propagated to durability. However, when a processor core issues a write, the data is first combined in a fill buffer and the modified cache line might then be store in the volatile cache of the processors. For durability, software therefore might need to explicitly evict modified cache lines from the processor caches. This is accomplished by the use of cache line flush instructions (CLFLUSH/CLFLUSHOPT/CLWB). In general, usage of CLFLUSHOPT is recommended over CLFLUSH, as detailed in Section 9.4.6, “CLFLUSH Instruction” and Section 9.4.7, “CLFLUSHOPT Instruction”.

For operations that will reuse the data that is being flushed, usage of CLWB is recommended. CLWB retains a copy of the cache line that is flushed to durability; as a result, for a subsequent access (reuse of data), the line will hit in the caches, reducing the latency of access. If only a small section of large memory ranges are actually modified, it might be worth tracking which sections have been changed and only flush these sections. In particular, if an operation system can track the pages that are written to (“dirty”), and only flushes those pages, it can be more efficient in cases when a small set of the range is written to. When almost the entire range is written to, it may be more efficient to implement the flushes using optimized code in user-space.

Figure 12-8 shows how msync in Linux* is more efficient when there only a small percentage of files that are dirty, whereas use of CLFLUSHOPT instructions in user space is more efficient when most of the file is dirty.

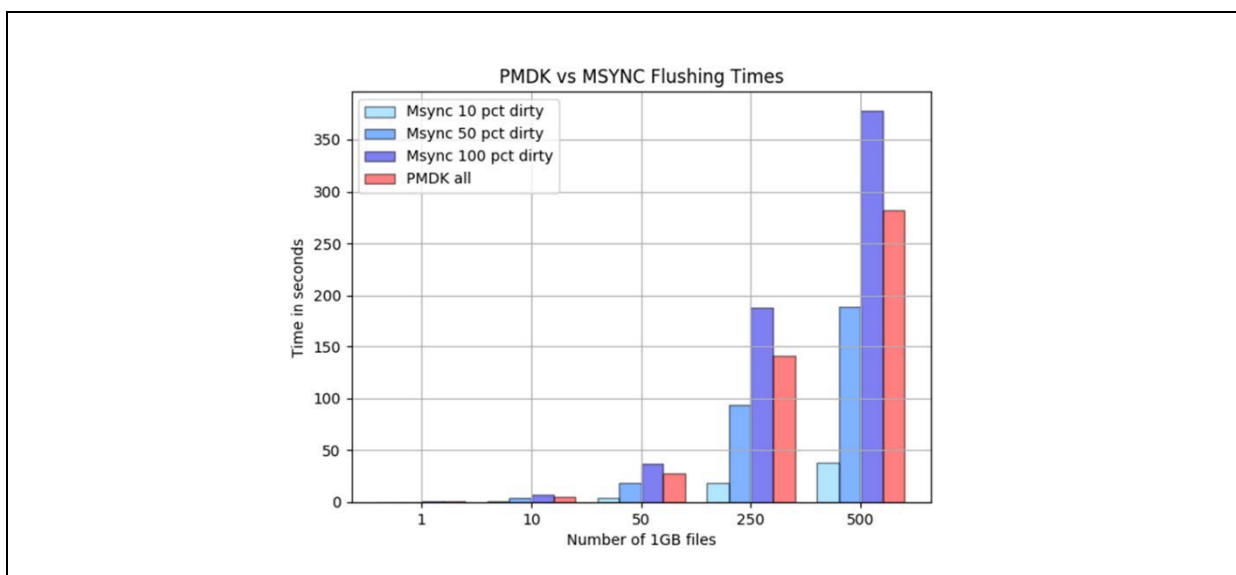

Figure 12-8. PMDK vs. MSYNC Flushing Times¹

NOTES:

1. When 10% or 50% of the files are dirty, it is more optimal from a software standpoint to use msync instead of flushes in user space. When the file is 100% dirty, the user space implementation (labeled pmrk) is more efficient.

12.5 POWER CONSUMPTION

In general, Intel Optane DC Persistent Memory Module bandwidth is constrained by power consumption, as illustrated with the figure below. If a power limit is imposed by software using techniques like RAPL (Runtime Average Power Limiting), then the overall bandwidth available is appropriately constrained.

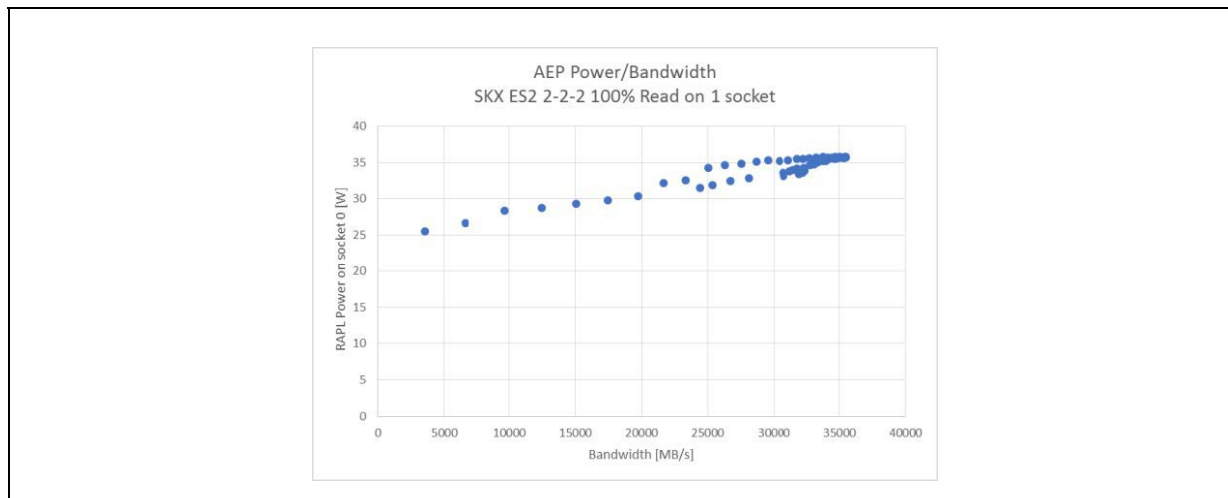

Figure 12-9. Bandwidth vs. Power Consumption

12.5.1 Read-Write Equivalence

On Intel Optane DC Persistent Memory Modules, writes are a lot more expensive in terms of power than reads. As a general guideline, one write consumes as much power as three read operations. This is in stark contrast with DRAM, where the power consumption of reads and writes does not differ as much. Therefore it is clear that writes are to be more sparingly used than reads. The implication of this is that write amplification by software is far more expensive than read amplification, when it comes to Intel Optane DC Persistent Memory Module accesses. This is to be considered while designing data structures, for example, a tree that needs to be rebalanced several times may incur a lot of writes compared to alternate data structures that may have more reads for look up, but fewer writes for insertion.

In case of a given a power budget, the read-write ratio determines the maximum bandwidth. For example, if several threads are writing to an Intel Optane DC Persistent Memory Module, the power consumed by the threads doing the writes is subtracted from the total power available on the platform. The figure below illustrates the read-write equivalence for Intel Optane DC Persistent Memory Module DIMMs within a total power budget.

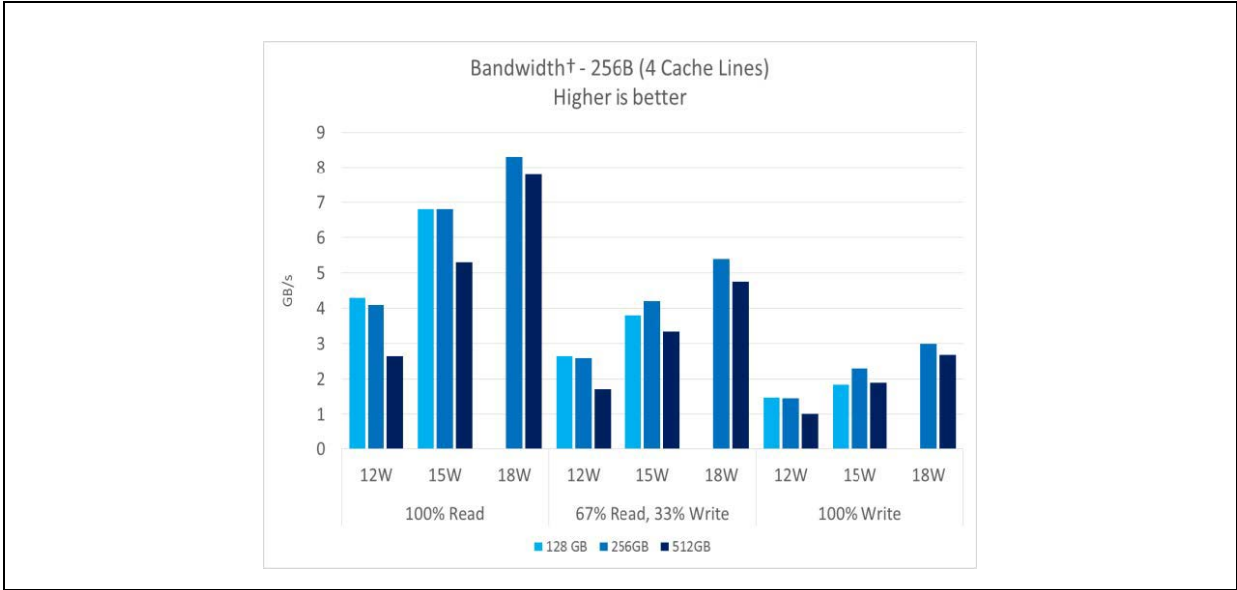

Figure 12-10. Read-Write Equivalence for Intel® Optane™ DC Persistent Memory Module DIMMs within Different Power Budgets¹

NOTES:

- 1. The bars on the left show the case for 100% reads. In this scenario, if we consider a power budget of 15W, then ~6.9GB/s of reads are possible. However, if we have the same power budget of 15W, only 2.1GB/s of writes are possible.

12.5.2 Spatial and Temporal Locality

An additional consideration while optimizing for power is to consider the effect of combining data accesses at 256B granularity. The bandwidth available to the application is extremely constrained when there is no locality in accesses, as shown in the figure below.

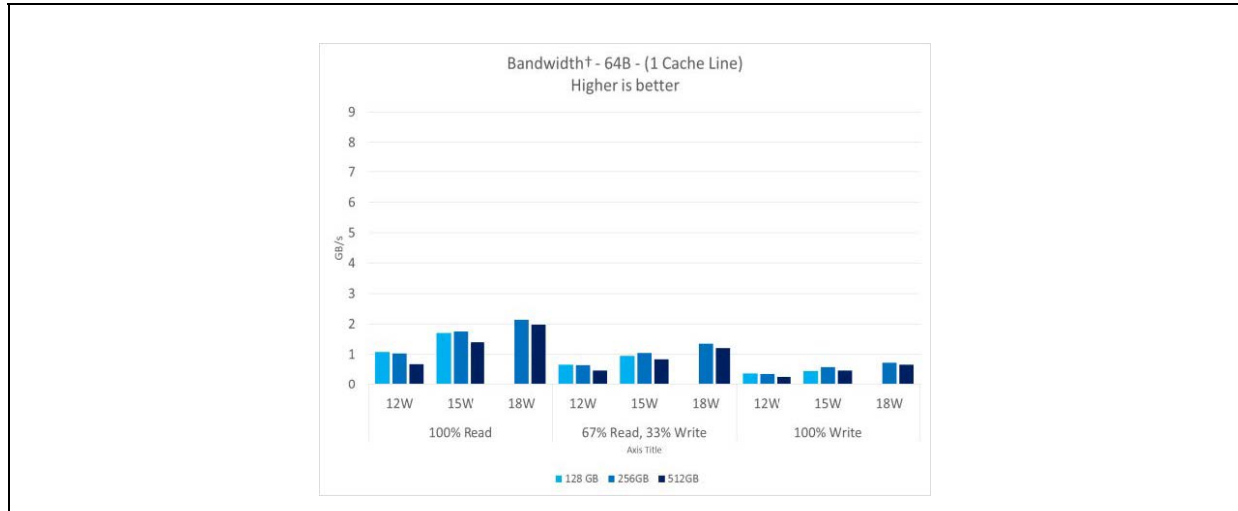

Figure 12-11. Bandwidth Available to Software when There is No Locality at 256B Granularity

From Figure 12-11, we can infer that it is critical to choose data structures that have good access locality at 256B in order to make good use of a given power budget from a bandwidth standpoint. More specifically, by comparing Figure 12-10 with Figure 12-11, we can observe that using access locality from a 256B window, the bandwidth improves by factors up to 3-4.

13.1 INTRODUCTION

This chapter describes coding guidelines for application software written to run in 64-bit mode. Some coding recommendations applicable to 64-bit mode are covered in Chapter 3. The guidelines in this chapter should be considered as an addendum to the coding guidelines described in Chapter 3 through Chapter 11.

Software that runs in either compatibility mode or legacy non-64-bit modes should follow the guidelines described in Chapter 3 through Chapter 11.

13.2 CODING RULES AFFECTING 64-BIT MODE

13.2.1 Use Legacy 32-Bit Instructions When Data Size Is 32 Bits

64-bit mode makes 16 general purpose 64-bit registers available to applications. If application data size is 32 bits, there is no need to use 64-bit registers or 64-bit arithmetic.

The default operand size for most instructions is 32 bits. The behavior of those instructions is to make the upper 32 bits all zeros. For example, when zeroing out a register, the following two instruction streams do the same thing, but the 32-bit version saves one instruction byte:

32-bit version:

```
xor eax, eax; Performs xor on lower 32bits and zeroes the upper 32 bits.
```

64-bit version:

```
xor rax, rax; Performs xor on all 64 bits.
```

This optimization holds true for the lower 8 general purpose registers: EAX, ECX, EBX, EDX, ESP, EBP, ESI, EDI. To access the data in registers R9-R15, the REX prefix is required. Using the 32-bit form there does not reduce code size.

Assembly/Compiler Coding Rule 56. (H impact, M generality) *Use the 32-bit versions of instructions in 64-bit mode to reduce code size unless the 64-bit version is necessary to access 64-bit data or additional registers.*

13.2.2 Use Extra Registers to Reduce Register Pressure

64-bit mode makes 8 additional 64-bit general purpose registers and 8 additional XMM registers available to applications. To access the additional registers, a single byte REX prefix is necessary. Using 8 additional registers can prevent the compiler from needing to spill values onto the stack.

Note that the potential increase in code size, due to the REX prefix, can increase cache misses. This can work against the benefit of using extra registers to access the data. When eight registers are sufficient for an algorithm, don't use the registers that require an REX prefix. This keeps the code size smaller.

Assembly/Compiler Coding Rule 57. (M impact, MH generality) When they are needed to reduce register pressure, use the 8 extra general purpose registers for integer code and 8 extra XMM registers for floating-point or SIMD code.

13.2.3 Effective Use of 64-Bit by 64-Bit Multiplication

Integer multiplication of 64-bit by 64-bit operands can produce a result that is 128 bits wide. The upper 64 bits of a 128-bit result may take a few cycles longer to be ready than the lower 64 bits. In a dependent chain of addition of integers wider than 128 bits, accessing the high 64-bit result of the multiplication should be delayed relative to the low 64-bit multiplication result for optimal software pipelining.

If the compiler can determine at compile time that the result of a multiplication will not exceed 64 bits, then the compiler should generate the multiplication instruction that produces a 64-bit result. If the compiler or assembly programmer cannot determine that the result will be less than 64 bits, then a multiplication that produces a 128-bit result is necessary.

Assembly/Compiler Coding Rule 58. (ML impact, M generality) Prefer 64-bit by 64-bit integer multiplication that produces 64-bit results over multiplication that produces 128-bit results.

Assembly/Compiler Coding Rule 59. (ML impact, M generality) Stagger accessing the high 64-bit result of a 128-bit multiplication after accessing the low 64-bit results.

In Sandy Bridge microarchitecture, the low 64-bit result of a 128-bit multiplication is ready to use in 3 cycles, and the high 64-bit result is ready one cycle after the low 64-bit result. This can speed up the calculation of integer multiplication and division of large integers.

13.2.4 Replace 128-bit Integer Division with 128-bit Multiplication

Modern compilers can transform expressions of integer division in high-level language code with a constant divisor into assembly sequences that use IMUL/MUL to replace IDIV/DIV instructions. Typically, compilers will replace a divisor value that is within the range of 32-bits if the divisor value is known at compile time. If the divisor value is not known at compile time or the divisor is greater than those represented by 32-bits, DIV or IDIV will be generated.

The latency of a DIV instruction with a 128-bit dividend is quite long. For dividend values greater than 64-bits, the latency can range from 70-90 cycles.

The basic technique that a compiler employs to transform integer division into 128-bit integer multiplication is based on the congruence principle of modular arithmetic. It can be easily extended to handle larger divisor values to take advantage of fast 128-bit IMUL/MUL operation.

The integer equation:

Dividend = Q * divisor + R, or

$Q = \text{floor}(\text{Dividend}/\text{Divisor}), R = \text{Dividend} - Q * \text{Divisor}$

Transform to the real number domain:

$\text{floor}(\text{Dividend}/\text{Divisor}) = \text{Dividend}/\text{Divisor} - R/\text{Divisor}$, is equivalent to

$Q * C2 = \text{Dividend} * (C2 / \text{divisor}) + R * C2 / \text{Divisor}$

One can choose $C2 = 2^N$ to control the rounding of the last term, then

$Q = ((\text{Dividend} * (C2 / \text{divisor})) \gg N) + ((R * C2 / \text{Divisor}) \gg N)$.

If the "divisor" is known at compile time, $(C2/\text{Divisor})$ can be pre-computed into a congruent constant $Cx = \text{Ceil}(C2/\text{divisor})$, then the quotient can be computed by an integer multiple, followed by a shift:

$Q = (\text{Dividend} * Cx) \gg N;$

$R = \text{Dividend} - ((\text{Dividend} * Cx) \gg N) * \text{divisor};$

The 128-bit IDIV/DIV instructions restrict the range of divisor, quotient, and remainder to be within 64-bits to avoid causing numerical exceptions. This presents a challenge for situations with either of the

three having a value near the upper bounds of 64-bit and for dividend values nearing the upper bound of 128 bits.

This challenge can be overcome with choosing a larger shift count N , and extending the $(\text{Dividend} * C_x)$ operation from the 128-bit range to the next computing-efficient range. For example, if $(\text{Dividend} * C_x)$ is greater than 128 bits and N is greater than 63 bits, one can take advantage of computing bits 191:64 of the 192-bit results using 128-bit MUL without implementing a full 192-bit multiplication.

A convenient way to choose the congruent constant C_x is as follows:

- If the range of dividend is within 64 bits: $N_{\min} \sim \text{BSR}(\text{Divisor}) + 63$.
- In situations of disparate dynamic range of quotient/remainder relative to the range of divisor, raise N accordingly so that quotient/remainder can be computed efficiently.

Consider the computation of quotient/remainder computation for the divisor 10^{16} on unsigned dividends near the range of 64-bits. Example 13-1 illustrates using the "MUL r64" instruction to handle a 64-bit dividend with 64-bit divisors.

Example 13-1. Compute 64-bit Quotient and Remainder with 64-bit Divisor

```

_Cx10to16:      ; Congruent constant for 10^16 with shift count 'N' = 117
  DD  0c44de15ch  ; floor ((2^117 / 10^16) + 1)
  DD  0e69594beh  ; Optimize length of Cx to reduce # of 128-bit multiplication
_tento16:      ; 10^16
  DD  6fc10000h
  DD  002386f2h

  mov  r9, qword ptr [rcx]  ; load 64-bit dividend value
  mov  rax, r9
  mov  rsi, _Cx10to16      ; Congruent Constant for 10^16 with shift count 117
  mul  [rsi]                ; 128-bit multiplication
  mov  r10, qword ptr 8[rsi] ; load divisor 10^16
  shr  rdx, 53;             ;
  mov  r8, rdx

  mov  rax, r8
  mul  r10                  ; 128-bit multiplication
  sub  r9, rax;             ;
  jae  remain
  sub  r8, 1                ; this may be off by one due to round up
  mov  rax, r8
  mul  r10                  ; 128-bit multiplication
  sub  r9, rax;             ;
remain:
  mov  rdx, r8              ; quotient
  mov  rax, r9              ; remainder

```

Example 13-2 shows a similar technique to handle a 128-bit dividend with 64-bit divisors.

Example 13-2. Quotient and Remainder of 128-bit Dividend with 64-bit Divisor

```

mov    rax, qword ptr [rcx]    ; load bits 63:0 of 128-bit dividend from memory
mov    rsi, _Cx10to16         ; Congruent Constant for 10^16 with shift count 117
mov    r9, qword ptr [rsi]     ; load Congruent Constant
mul    r9                     ; 128-bit multiplication
xor    r11, r11                ; clear accumulator
mov    rax, qword ptr 8[rcx]   ; load bits 127:64 of 128-bit dividend
shr    rdx, 53;                ;
mov    r10, rdx                ; initialize bits 127:64 of 192 bit result
mul    r9                     ; Accumulate to bits 191:128
add    rax, r10;               ;
adc    rdx, r11;               ;
shr    rax, 53;                ;
shl    rdx, 11;                ;
or     rdx, rax;               ;
mov    r8, qword ptr 8[rsi]    ; load Divisor 10^16
mov    r9, rdx;                ; approximate quotient, may be off by 1
mov    rax, r8
mul    r9                     ; will quotient * divisor > dividend?
sub    rdx, qword ptr 8[rcx]   ;
sbb   rax, qword ptr [rcx]    ;

    jb     remain
sub    r9, 1                    ; this may be off by one due to round up
mov    rax, r8                  ; retrieve Divisor 10^16
mul    r9                       ; final quotient * divisor
sub    rax, qword ptr [rcx]     ;
sbb   rdx, qword ptr 8[rcx]    ;
remain:
mov    rdx, r9                  ; quotient
neg    rax                      ; remainder

```

The techniques illustrated in Example 13-1 and Example 13-2 can increase the speed of the remainder/quotient calculation of 128-bit dividends to at or below the cost of a 32-bit integer division.

Extending the technique above to deal with a divisor greater than 64-bits is relatively straightforward. One optimization worth considering is to choose a shift count $N > 128$ bits. This can reduce the number of 128-bit MUL needed to compute the relevant upper bits of $(\text{Dividend} * C_x)$.

13.2.5 Sign Extension to Full 64-Bits

When in 64-bit mode, processors based on Intel NetBurst microarchitecture can sign-extend to 64 bits in a single micro-op. In 64-bit mode, when the destination is 32 bits, the upper 32 bits must be zeroed.

Zeroing the upper 32 bits requires an extra micro-op and is less optimal than sign extending to 64 bits. While sign extending to 64 bits makes the instruction one byte longer, it reduces the number of micro-ops that the trace cache has to store, improving performance.

For example, to sign-extend a byte into ESI, use:

```
movsx rsi, BYTE PTR[rax]
```

instead of:

```
movsx esi, BYTE PTR[rax]
```

If the next instruction uses the 32-bit form of esi register, the result will be the same. This optimization can also be used to break an unintended dependency. For example, if a program writes a 16-bit value to a register and then writes the register with an 8-bit value, if bits 15:8 of the destination are not needed, use the sign-extended version of writes when available.

For example:

```
mov r8w, r9w; Requires a merge to preserve
; bits 63:15.
mov r8b, r10b; Requires a merge to preserve bits 63:8
```

Can be replaced with:

```
movsx r8, r9w ; If bits 63:8 do not need to be
; preserved.
movsx r8, r10b ; If bits 63:8 do not need to
; be preserved.
```

In the above example, the moves to R8W and R8B both require a merge to preserve the rest of the bits in the register. There is an implicit real dependency on R8 between the 'MOV R8W, R9W' and 'MOV R8B, R10B'. Using MOVSX breaks the real dependency and leaves only the output dependency, which the processor can eliminate through renaming.

For processors based on Intel Core microarchitecture, zeroing the upper 32 bits is faster than sign-extend to 64 bits. For processors based on Nehalem microarchitecture, zeroing or sign-extend the upper bits is single micro-op.

13.3 ALTERNATE CODING RULES FOR 64-BIT MODE

13.3.1 Use 64-Bit Registers Instead of Two 32-Bit Registers for 64-Bit Arithmetic Result

Legacy 32-bit mode offers the ability to support extended precision integer arithmetic (such as 64-bit arithmetic). However, 64-bit mode offers native support for 64-bit arithmetic. When 64-bit integers are desired, use the 64-bit forms of arithmetic instructions.

In 32-bit legacy mode, getting a 64-bit result from a 32-bit by 32-bit integer multiply requires three registers; the result is stobred in 32-bit chunks in the EDX:EAX pair. When the instruction is available in 64-bit mode, using the 32-bit version of the instruction is not the optimal implementation if a 64-bit result is desired. Use the extended registers.

For example, the following code sequence loads the 32-bit values sign-extended into the 64-bit registers and performs a multiply:

```
movsx rax, DWORD PTR[x]
movsx rcx, DWORD PTR[y]
imul rax, rcx
```

The 64-bit version above is more efficient than using the following 32-bit version:

```
mov eax, DWORD PTR[x]
mov ecx, DWORD PTR[y]
imul ecx
```

In the 32-bit case above, EAX is required to be a source. The result ends up in the EDX:EAX pair instead of in a single 64-bit register.

Assembly/Compiler Coding Rule 60. (ML impact, M generality) Use the 64-bit versions of multiply for 32-bit integer multiplies that require a 64 bit result.

To add two 64-bit numbers in 32-bit legacy mode, the add instruction followed by the addc instruction is used. For example, to add two 64-bit variables (X and Y), the following four instructions could be used:

```
mov eax, DWORD PTR[X]
mov edx, DWORD PTR[X+4]
add eax, DWORD PTR[Y]
adc edx, DWORD PTR[Y+4]
```

The result will end up in the two-register EDX:EAX.

In 64-bit mode, the above sequence can be reduced to the following:

```
mov rax, QWORD PTR[X]
add rax, QWORD PTR[Y]
```

The result is stored in rax. One register is required instead of two.

Assembly/Compiler Coding Rule 61. (ML impact, M generality) Use the 64-bit versions of add for 64-bit adds.

13.3.2 Using Software Prefetch

Intel recommends that software developers follow the recommendations in Chapter 3 and Chapter 9 when considering the choice of organizing data access patterns to take advantage of the hardware prefetcher (versus using software prefetch).

Assembly/Compiler Coding Rule 62. (L impact, L generality) If software prefetch instructions are necessary, use the prefetch instructions provided by SSE.

CHAPTER 14

SSE4.2 AND SIMD PROGRAMMING FOR TEXT-PROCESSING/LEXING/PARSING

String/text processing spans a discipline that often employs techniques different from traditional SIMD integer vector processing. Much of the traditional string/text algorithms are character based, where characters may be represented by encodings (or code points) of fixed or variable byte sizes. Textual data represents a vast amount of raw data and often carrying contextual information. The contextual information embedded in raw textual data often requires algorithmic processing dealing with a wide range of attributes, such as character values, character positions, character encoding formats, subsetting of character sets, strings of explicit or implicit lengths, tokens, delimiters; contextual objects may be represented by sequential characters within a pre-defined character subsets (e.g. decimal-valued strings); textual streams may contain embedded state transitions separating objects of different contexts (e.g., tag-delimited fields).

Traditional Integer SIMD vector instructions may, in some simpler situations, be successful to speed up simple string processing functions. SSE4.2 includes four new instructions that offer advances to computational algorithms targeting string/text processing, lexing and parsing of either unstructured or structured textual data.

14.1 SSE4.2 STRING AND TEXT INSTRUCTIONS

SSE4.2 provides four instructions, PCMPSTR/PCMPSTRM/PCMPISTR/PCMPISTRM that can accelerate string and text processing by combining the efficiency of SIMD programming techniques and the lexical primitives that are embedded in these 4 instructions. Simple examples of these instructions include string length determination, direct string comparison, string case handling, delimiter/token processing, locating word boundaries, locating sub-string matches in large text blocks. Sophisticated application of SSE4.2 can accelerate XML parsing and Schema validation.

Processor's support for SSE4.2 is indicated by the feature flag value returned in ECX [bit 20] after executing CPUID instruction with EAX input value of 1 (i.e. SSE4.2 is supported if CPUID.01H:ECX.SSE4_2 [bit 20] = 1). Therefore, software must verify CPUID.01H:ECX.SSE4_2 [bit 20] is set before using these 4 instructions. (Verifying CPUID.01H:ECX.SSE4_2 = 1 is also required before using PCMPGTQ or CRC32. Verifying CPUID.01H:ECX.POPCNT[Bit 23] = 1 is required before using the POPCNT instruction.)

These string/text processing instructions work by performing up to 256 comparison operations on text fragments. Each text fragment can be 16 bytes. They can handle fragments of different formats: either byte or word elements. Each of these four instructions can be configured to perform four types of parallel comparison operation on two text fragments.

The aggregated intermediate result of a parallel comparison of two text fragments become a bit patterns: 16 bits for processing byte elements or 8 bits for word elements. These instruction provide additional flexibility, using bit fields in the immediate operand of the instruction syntax, to configure an unary transformation (polarity) on the first intermediate result.

Lastly, the instruction's immediate operand offers a output selection control to further configure the flexibility of the final result produced by the instruction. The rich configurability of these instruction is summarized in Figure 14-1.

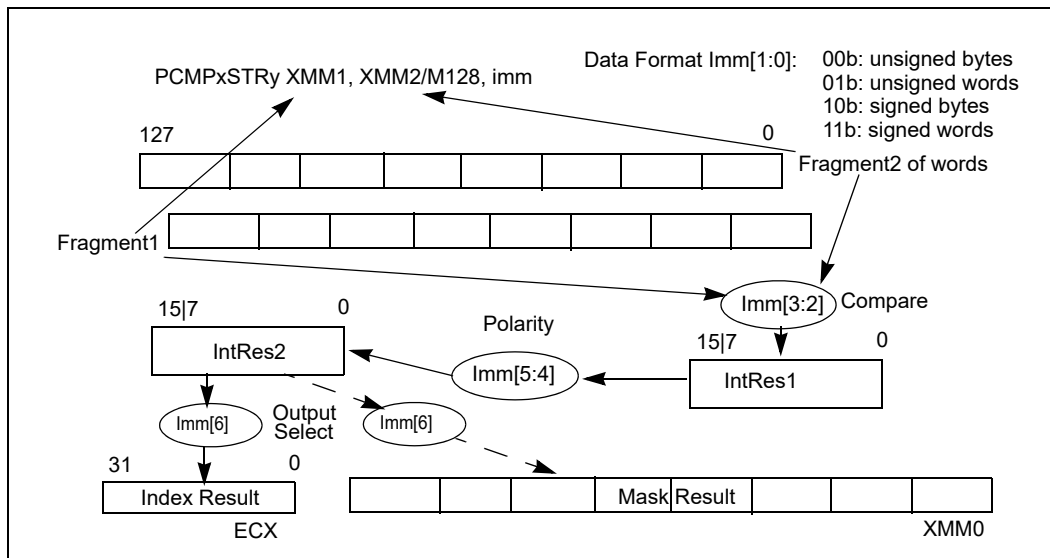

Figure 14-1. SSE4.2 String/Text Instruction Immediate Operand Control

The PCMPxSTRy instructions produce final result as an integer index in ECX, the PCMPxSTRM instructions produce final result as a bit mask in the XMM0 register. The PCMPISTRy instructions support processing string/text fragments using implicit length control via null termination for handling string/text of unknown size. the PCMPSTRy instructions support explicit length control via EDX:EAX register pair to specify the length text fragments in the source operands.

The first intermediate result, IntRes1, is an aggregated result of bit patterns from parallel comparison operations done on pairs of data elements from each text fragment, according to the imm[3:2] bit field encoding, see Table 14-1.

Table 14-1. SSE4.2 String/Text Instructions Compare Operation on N-elements

Imm[3:2]	Name	IntRes1[i] is TRUE if	Potential Usage
00B	Equal Any	Element i in fragment2 matches any element j in fragment1	Tokenization, XML parser
01B	Ranges	Element i in fragment2 is within any range pairs specified in fragment1	Subsetting, Case handling, XML parser, Schema validation
10B	Equal Each	Element i in fragment2 matches element i in fragment1	Strcmp()
11B	Equal Ordered	Element i and subsequent, consecutive valid elements in fragment2 match fully or partially with fragment1 starting from element 0	Substring Searches, KMP, Strstr()

Input data element format selection using imm[1:0] can support signed or unsigned byte/word elements.

The bit field imm[5:4] allows applying a unary transformation on IntRes1, see Table 14-2.

Table 14-2. SSE4.2 String/Text Instructions Unary Transformation on IntRes1

Imm[5:4]	Name	IntRes2[i] =	Potential Usage
00B	No Change	IntRes1[i]	
01B	Invert	-IntRes1[i]	
10B	No Change	IntRes1[i]	
11B	Mask Negative	IntRes1[i] if element i of fragment2 is invalid, otherwise - IntRes1[i]	

The output selection field, imm[6] is described in Table 14-3.

Table 14-3. SSE4.2 String/Text Instructions Output Selection Imm[6]

Imm[6]	Instruction	Final Result	Potential Usage
0B	PCMPxSTRI	ECX = offset of least significant bit set in IntRes2 if IntRes2 != 0, otherwise ECX = number of data element per 16 bytes	
0B	PCMPxSTRM	XMM0 = ZeroExtend(IntRes2);	
1B	PCMPxSTRI	ECX = offset of most significant bit set in IntRes2 if IntRes2 != 0, otherwise ECX = number of data element per 16 bytes	
1B	PCMPxSTRM	Data element i of XMM0 = SignExtend(IntRes2[i]);	

The comparison operation on each data element pair is defined in Table 14-4. Table 14-4 defines the type of comparison operation between valid data elements (last row of Table 14-4) and boundary conditions when the fragment in a source operand may contain invalid data elements (rows 1 through 3 of Table 14-4). Arithmetic comparison are performed only if both data elements are valid element in fragment1 and fragment2, as shown in row 4 of Table 14-4.

Table 14-4. SSE4.2 String/Text Instructions Element-Pair Comparison Definition

Fragment1 Element	Fragment2 Element	Imm[3:2]= 00B, Equal Any	Imm[3:2]= 01B, Ranges	Imm[3:2]= 10B, Equal Each	Imm[3:2]= 11B, Equal Ordered
Invalid	Invalid	Force False	Force False	Force True	Force True
Invalid	Valid	Force False	Force False	Force False	Force True
Valid	Invalid	Force False	Force False	Force False	Force False
Valid	Valid	Compare	Compare	Compare	Compare

The string and text processing instruction provides several aid to handle end-of-string situations, see Table 14-5. Additionally, the PCMPxSTRy instructions are designed to not require 16-byte alignment to simplify text processing requirements.

Table 14-5. SSE4.2 String/Text Instructions Eflags Behavior

EFLAGS	Description	Potential Usage
CF	Reset if IntRes2 = 0; Otherwise set	When CF=0, ECX= #of data element to scan next
ZF	Reset if entire 16-byte fragment2 is valid	likely end-of-string
SF	Reset if entire 16-byte fragment1 is valid	
OF	IntRes2[0];	

14.1.1 CRC32

CRC32 instruction computes the 32-bit cyclic redundancy checksum signature for byte/word/dword or qword stream of data. It can also be used as a hash function. For example, a dictionary uses hash indices to de-reference strings. CRC32 instruction can be easily adapted for use in this situation.

Example 14-1 shows a straight forward hash function that can be used to evaluate the hash index of a string to populate a hash table. Typically, the hash index is derived from the hash value by taking the remainder of the hash value modulo the size of a hash table.

Example 14-1. A Hash Function Examples

```
unsigned int hash_str(unsigned char* pStr)
{
    unsigned int hVal = (unsigned int)(*pStr++);
    while (*pStr)
    {
        hVal = (hashVal * CONST_A) + (hVal >> 24) + (unsigned int)(*pStr++);
    }
    return hVal;
}
```

CRC32 instruction can be use to derive an alternate hash function. Example 14-2 takes advantage the 32-bit granular CRC32 instruction to update signature value of the input data stream. For string of small to moderate sizes, using the hardware accelerated CRC32 can be twice as fast as Example 14-1.

Example 14-2. Hash Function Using CRC32

```
static unsigned cn_7e = 0x7efefeff, Cn_81 = 0x81010100;

unsigned int hash_str_32_crc32x(unsigned char* pStr)
{
    unsigned *pDW = (unsigned *) &pStr[1];
    unsigned short *pWd = (unsigned short *) &pStr[1];
    unsigned int tmp, hVal = (unsigned int)(*pStr);
    if( !pStr[1] );
    else {
        tmp = ((pDW[0] +cn_7e) ^ (pDW[0]^ -1)) & Cn_81;
        while ( !tmp ) // loop until there is byte in *pDW had 0x00
        {
            hVal = _mm_crc32_u32 (hVal, *pDW ++);
            tmp = ((pDW[0] +cn_7e) ^ (pDW[0]^ -1)) & Cn_81;
        };
        if(!pDW[0]);
        else if(pDW[0] < 0x100) { // finish last byte that's non-zero
            hVal = _mm_crc32_u8 (hVal, pDW[0]);
        }
    }
}
```

Example 14-2. Hash Function Using CRC32 (Contd.)

```

    else if(pDw[0] < 0x10000) { // finish last two byte that's non-zero
        hVal = _mm_crc32_u16 (hVal, pDw[0]);
    }
    else { // finish last three byte that's non-zero
        hVal = _mm_crc32_u32 (hVal, pDw[0]);
    }
}
return hVal;
}

```

14.2 USING SSE4.2 STRING AND TEXT INSTRUCTIONS

String libraries provided by high-level languages or as part of system library are used in a wide range of situations across applications and privileged system software. These situations can be accelerated using a replacement string library that implements PCMPSTR/PCMPSTRM/PCMPSTRM/PCMPSTRM.

Although system-provided string library provides standardized string handling functionality and interfaces, most situations dealing with structured document processing requires considerable more sophistication, optimization, and services not available from system-provided string libraries. For example, structured document processing software often architect different class objects to provide building block functionality to service specific needs of the application. Often application may choose to disperse equivalent string library services into separate classes (string, lexer, parser) or integrate memory management capability into string handling/lexing/parsing objects.

PCMPSTR/PCMPSTRM/PCMPSTRM/PCMPSTRM instructions are general-purpose primitives that software can use to build replacement string libraries or build class hierarchy to provide lexing/parsing services for structured document processing. XML parsing and schema validation are examples of the latter situations.

Unstructured, raw text/string data consist of characters, and have no natural alignment preferences. Therefore, PCMPSTR/PCMPSTRM/PCMPSTRM/PCMPSTRM instructions are architected to not require the 16-Byte alignment restrictions of other 128-bit SIMD integer vector processing instructions.

With respect to memory alignment, PCMPSTR/PCMPSTRM/PCMPSTRM/PCMPSTRM support unaligned memory loads like other unaligned 128-bit memory access instructions, e.g. MOVQDU.

Unaligned memory accesses may encounter special situations that require additional coding techniques, depending on the code running in ring 3 application space or in privileged space. Specifically, an unaligned 16-byte load may cross page boundary. Section 14.2.1 discusses a technique that application code can use. Section 14.2.2 discusses the situation string library functions needs to deal with. Section 14.3 gives detailed examples of using PCMPSTR/PCMPSTRM/PCMPSTRM/PCMPSTRM instructions to implement equivalent functionality of several string library functions in situations that application code has control over memory buffer allocation.

14.2.1 Unaligned Memory Access and Buffer Size Management

In application code, the size requirements for memory buffer allocation should consider unaligned SIMD memory semantics and application usage.

For certain types of application usage, it may be desirable to make distinctions between valid buffer range limit versus valid application data size (e.g. a video frame). The former must be greater or equal to the latter.

To support algorithms requiring unaligned 128-bit SIMD memory accesses, memory buffer allocation by a caller function should consider adding some pad space so that a callee function can safely use the address pointer safely with unaligned 128-bit SIMD memory operations.

The minimal padding size should be the width of the SIMD register that might be used in conjunction with unaligned SIMD memory access.

14.2.2 Unaligned Memory Access and String Library

String library functions may be used by application code or privileged code. String library functions must be careful not to violate memory access rights. Therefore, a replacement string library that employ SIMD unaligned access must employ special techniques to ensure no memory access violation occur.

Section 14.3.6 provides an example of a replacement string library function implemented with SSE4.2 and demonstrates a technique to use 128-bit unaligned memory access without unintentionally crossing page boundary.

14.3 SSE4.2 APPLICATION CODING GUIDELINE AND EXAMPLES

Software implementing SSE4.2 instruction must use CPUID feature flag mechanism to verify processor's support for SSE4.2. Details can be found in CHAPTER 12 of *Intel® 64 and IA-32 Architectures Software Developer's Manual, Volume 1* and in CPUID of CHAPTER 3 in *Intel® 64 and IA-32 Architectures Software Developer's Manual, Volume 2A*.

In the following sections, we use several examples in string/text processing of progressive complexity to illustrates the basic techniques of adapting the SIMD approach to implement string/text processing using PCMPxSTRy instructions in SSE4.2. For simplicity, we will consider string/text in byte data format in situations that caller functions have allocated sufficient buffer size to support unaligned 128-bit SIMD loads from memory without encountering side-effects of cross page boundaries.

14.3.1 Null Character Identification (Strlen equivalent)

The most widely used string function is probably `strlen()`. One can view the lexing requirement of `strlen()` is to identify the null character in a text block of unknown size (end of string condition). Brute-force, byte-granular implementation fetches data inefficiently by loading one byte at a time.

Optimized implementation using general-purpose instructions can take advantage of dword operations in 32-bit environment (and qword operations in 64-bit environment) to reduce the number of iterations.

A 32-bit assembly implementation of `strlen()` is shown Example 14-3. The peak execution throughput of handling EOS condition is determined by eight ALU instructions in the main loop.

Example 14-3. Strlen() Using General-Purpose Instructions

```
int strlen_asm(const char* s1)
{int len = 0;
  _asm{
    mov ecx, s1
    test ecx, 3 ; test addr aligned to dword
    je short _main_loop1 ; dword aligned loads would be faster
  _malign_str1:
    mov al, byte ptr [ecx] ; read one byte at a time
    add ecx, 1
    test al, al ; if we find a null, go calculate the length
    je short _byte3a
      (continue)
```

Example 14-3. Strlen() Using General-Purpose Instructions (Contd.)

```

test ecx, 3; test if addr is now aligned to dword
jne short _malign_str1; if not, repeat
align16
_main_loop1; read each 4-byte block and check for a NULL char in the dword
mov eax, [ecx]; read 4 byte to reduce loop count
mov edx, 7efefeffh
add edx, eax
xor eax, -1
xor eax, edx
add ecx, 4; increment address pointer by 4
test eax, 81010100h; if no null code in 4-byte stream, do the next 4 bytes
je short _main_loop1
; there is a null char in the dword we just read,
; since we already advanced pointer ecx by 4, and the dword is lost
mov eax, [ecx -4]; re-read the dword that contain at least a null char
test al, al; if byte0 is null
je short _byte0a; the least significant byte is null
test ah, ah; if byte1 is null
je short _byte1a
test eax, 00ff0000h; if byte2 is null
je short _byte2a
test eax, 00ff000000h; if byte3 is null
je short _byte3a
jmp short _main_loop1
_byte3a:
; we already found the null, but pointer already advanced by 1
lea eax, [ecx-1]; load effective address corresponding to null code
mov ecx, s1
sub eax, ecx; difference between null code and start address
jmp short _resulta
_byte2a:

lea eax, [ecx-2]
mov ecx, s1
sub eax, ecx
jmp short _resulta
_byte1a:
lea eax, [ecx-3]
mov ecx, s1
sub eax, ecx
jmp short _resulta
_byte0a:
lea eax, [ecx-4]
mov ecx, s1
sub eax, ecx
_resulta:
mov len, eax; store result
}
return len;
}

```

The equivalent functionality of EOS identification can be implemented using PCMPISTRI. Example 14-4 shows a simplistic SSE4.2 implementation to scan a text block by loading 16-byte text fragments and locate the null termination character. Example 14-5 shows the optimized SSE4.2 implementation that demonstrates the effectiveness of memory disambiguation to improve instruction-level parallelism.

Example 14-4. Sub-optimal PCMPISTRI Implementation of EOS handling

```

static char ssc2[16]= {0x1, 0xff, 0x00, }; // range values for non-null characters

int strlen_un_optimized(const char* s1)
{int len = 0;
  _asm{
    mov  eax, s1
    movdquxmm2, ssc2 ; load character pair as range (0x01 to 0xff)
    xor  ecx, ecx ; initial offset to 0
        (continue)

_loopc:
    add  eax, ecx ; update addr pointer to start of text fragment
    pcmpestri xmm2, [eax], 14h; unsigned bytes, ranges, invert, lsb index returned to ecx
        ; if there is a null char in the 16Byte fragment at [eax], zf will be set.
        ; if all 16 bytes of the fragment are non-null characters, ECX will return 16,
    jnz  short _loopc; xmm1 has no null code, ecx has 16, continue search
    ; we have a null code in xmm1, ecx has the offset of the null code i
    add  eax, ecx ; add ecx to the address of the last fragment2/xmm1
    mov  edx, s1; retrieve effective address of the input string
    sub  eax, edx;the string length
    mov  len, eax; store result
  }
  return len;
}

```

The code sequence shown in Example 14-4 has a loop consisting of three instructions. From a performance tuning perspective, the loop iteration has loop-carry dependency because address update is done using the result (ECX value) of a previous loop iteration. This loop-carry dependency deprives the out-of-order engine's capability to have multiple iterations of the instruction sequence making forward progress. The latency of memory loads, the latency of these instructions, any bypass delay could not be amortized by OOO execution in the presence of loop-carry dependency.

A simple optimization technique to eliminate loop-carry dependency is shown in Example 14-5.

Using memory disambiguation technique to eliminate loop-carry dependency, the cumulative latency exposure of the 3-instruction sequence of Example 14-5 is amortized over multiple iterations, the net cost of executing each iteration (handling 16 bytes) is less than 3 cycles. In contrast, handling 4 bytes of string data using 8 ALU instructions in Example 14-3 will also take a little less than 3 cycles per iteration. Whereas each iteration of the code sequence in Example 14-4 will take more than 10 cycles because of loop-carry dependency.

Example 14-5. Strlen() Using PCMPISTRI without Loop-Carry Dependency

```

int strlen_sse4_2(const char* s1)
{int len = 0;
  _asm{
    mov  eax, s1
    movdquxmm2, ssc2 ; load character pair as range (0x01 to 0xff)
    xor  ecx, ecx ; initial offset to 0
    sub  eax, 16 ; address arithmetic to eliminate extra instruction and a branch

```

Example 14-5. Strlen() Using PCMPISTRI without Loop-Carry Dependency (Contd.)

```

_loopc:
  add  eax, 16 ; adjust address pointer and disambiguate load address for each iteration
  pcmpestri xmm2, [eax], 14h; unsigned bytes, ranges, invert, lsb index returned to ecx
    ; if there is a null char in [eax] fragment, zf will be set.
    ; if all 16 bytes of the fragment are non-null characters, ECX will return 16,
  jnz short _loopc ; ECX will be 16 if there is no null byte in [eax], so we disambiguate
_endofstring:
  add  eax, ecx    ; add ecx to the address of the last fragment
  mov  edx, s1; retrieve effective address of the input string
  sub  eax, edx; the string length
  mov  len, eax; store result
  }
  return len;
}

```

SSE4.2 Coding Rule 5. (H impact, H generality) Loop-carry dependency that depends on the ECX result of PCMPSTRI/PCMPSTRM/PCMPISTRI/PCMPISTRM for address adjustment must be minimized. Isolate code paths that expect ECX result will be 16 (bytes) or 8 (words), replace these values of ECX with constants in address adjustment expressions to take advantage of memory disambiguation hardware.

14.3.2 White-Space-Like Character Identification

Character-granular-based text processing algorithms have developed techniques to handle specific tasks to remedy the efficiency issue of character-granular approaches. One such technique is using look-up tables for character subset classification. For example, some application may need to separate alphanumeric characters from white-space-like characters. More than one character may be treated as white-space characters.

Example 14-6 illustrates a simple situation of identifying white-space-like characters for the purpose of marking the beginning and end of consecutive non-white-space characters.

Example 14-6. WordCnt() Using C and Byte-Scanning Technique

```

// Counting words involves locating the boundary of contiguous non-whitespace characters.
// Different software may choose its own mapping of white space character set.
// This example employs a simple definition for tutorial purpose:
// Non-whitespace character set will consider: A-Z, a-z, 0-9, and the apostrophe mark '
// The example uses a simple technique to map characters into bit patterns of square waves
// we can simply count the number of falling edges

static char alphrange[16]= {0x27, 0x27, 0x30, 0x39, 0x41, 0x5a, 0x61, 0x7a, 0x0};
static char alp_map8[32] = {0x0, 0x0, 0x0, 0x0, 0x80, 0x0, 0xff, 0x3, 0xfe, 0xff, 0xff, 0x7, 0xfe, 0xff, 0xff, 0x7}; // 32
byte lookup table, 1s map to bit patterns of alpha numerics in alphrange
int wordcnt_c(const char* s1)
{int i, j, cnt = 0;
 char cc, cc2;
 char flg[3]; // capture the a wavelet to locate a falling edge
  cc2 = cc = s1[0];
  // use the compacted bit pattern to consolidate multiple comparisons into one look up
  if (alp_map8[cc>>3] & (1<<(cc & 7)))
  { flg[1] = 1; } // non-white-space char that is part of a word,
  (continue)
}

```

Example 14-6. WordCnt() Using C and Byte-Scanning Technique (Contd.)

```

// we're including apostrophe in this example since counting the
// following 's' as a separate word would be kind of silly
else
{ flg[1] = 0; } // 0: whitespace, punctuations not be considered as part of a word

i = 1; // now we're ready to scan through the rest of the block
// we'll try to pick out each falling edge of the bit pattern to increment word count.
// this works with consecutive white spaces, dealing with punctuation marks, and
// treating hyphens as connecting two separate words.
while (cc2 )
{ cc2 = s1[i];
  if( alp_map8[cc2>>3] & ( 1<< ( cc2 & 7) ) )
  { flg[2] = 1; } // non-white-space
  else
  { flg[2] = 0; } // white-space-like

  if( !flg[2] && flg[1] )
  { cnt ++; } // found the falling edge
  flg[1] = flg[2];
  i++;
}
return cnt;
}

```

In Example 14-6, a 32-byte look-up table is constructed to represent the ascii code values 0x0-0xff, and partitioned with each bit of 1 corresponding to the specified subset of characters. While this bit-lookup technique simplifies the comparison operations, data fetching remains byte-granular.

Example 14-7 shows an equivalent implementation of counting words using PCMPISTRM. The loop iteration is performed at 16-byte granularity instead of byte granularity. Additionally, character set subsetting is easily expressed using range value pairs and parallel comparisons between the range values and each byte in the text fragment are performed by executing PCMPISTRM once.

Example 14-7. WordCnt() Using PCMPISTRM

```

// an SSE4.2 example of counting words using the definition of non-whitespace character
// set of {A-Z, a-z, 0-9, '}. Each text fragment (up to 16 bytes) are mapped to a
// 16-bit pattern, which may contain one or more falling edges. Scanning bit-by-bit
// would be inefficient and goes counter to leveraging SIMD programming techniques.
// Since each falling edge must have a preceding rising edge, we take a finite
// difference approach to derive a pattern where each rising/falling edge maps to 2-bit pulse,
// count the number of bits in the 2-bit pulses using popcnt and divide by two.
int wdcnt_sse4_2(const char* s1)
{int len = 0;
  _asm{
    mov  eax, s1
    movdquxmm3, alphnrange ; load range value pairs to detect non-white-space codes
    xor  ecx, ecx
    xor  esi, esi
    xor  edx, edx
      (continue)

```

Example 14-7. WordCnt() Using PCMPISTRM (Contd.)

```

movdquxmm1, [eax]
pcmpistrm xmm3, xmm1, 04h ; white-space-like char becomes 0 in xmm0[15:0]
movdqa xmm4, xmm0
movdqa xmm1, xmm0
psrld xmm4, 15 ; save MSB to use in next iteration
movdqa xmm5, xmm1
psllw xmm5, 1; lsb is effectively mapped to a white space
pxor xmm5, xmm0; the first edge is due to the artifact above
pextrd edi, xmm5, 0
jz _lastfragment; if xmm1 had a null, zf would be set
popcnt edi, edi; the first fragment will include a rising edge
add esi, edi
mov ecx, 16
_loopc:
add eax, ecx ; advance address pointer
movdquxmm1, [eax]
pcmpistrm xmm3, xmm1, 04h ; white-space-like char becomes 0 in xmm0[15:0]
movdqa xmm5, xmm4 ; retrieve the MSB of the mask from last iteration
movdqa xmm4, xmm0
psrld xmm4, 15 ; save mSB of this iteration for use in next iteration
movdqa xmm1, xmm0

psllw xmm1, 1
por xmm5, xmm1 ; combine MSB of last iter and the rest from current iter
pxor xmm5, xmm0; differentiate binary wave form into pattern of edges
pextrdedi, xmm5, 0 ; the edge patterns has (1 bit from last, 15 bits from this round)
jz _lastfragment; if xmm1 had a null, zf would be set
mov ecx, 16; xmm1, had no null char, advance 16 bytes
popcntedi, edi; count both rising and trailing edges
add esi, edi; keep a running count of both edges
jmp short _loopc
_lastfragment:
popcntedi, edi; count both rising and trailing edges
add esi, edi; keep a running count of both edges
shr esi, 1 ; word count corresponds to the trailing edges
mov len, esi
}
return len;
}

```

14.3.3 Substring Searches

Strstr() is a common function in the standard string library. Typically, A library may implement strstr(sTarg, sRef) with a brute-force, byte-granular technique of iterative comparisons between the reference string with a round of string comparison with a subset of the target string. Brute-force, byte-granular techniques provide reasonable efficiency when the first character of the target substring and the reference string are different, allowing subsequent string comparisons of target substrings to proceed forward to the next byte in the target string.

When a string comparison encounters partial matches of several characters (i.e. the sub-string search found a partial match starting from the beginning of the reference string) and determined the partial match led to a false-match. The brute-force search process need to go backward and restart string comparisons from a location that had participated in previous string comparison operations. This is referred to as re-trace inefficiency of the brute-force substring search algorithm. See Figure 14-2.

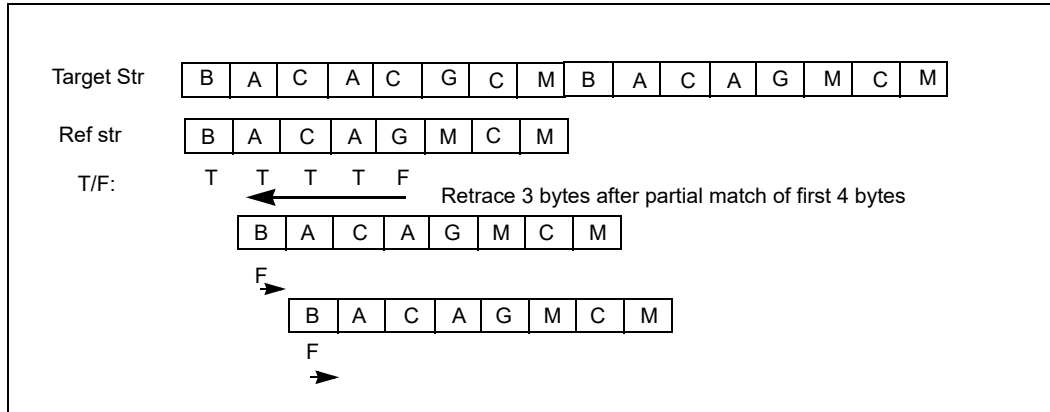

Figure 14-2. Retrace Inefficiency of Byte-Granular, Brute-Force Search

The Knuth, Morris, Pratt algorithm¹ (KMP) provides an elegant enhancement to overcome the re-trace inefficiency of brute-force substring searches. By deriving an overlap table that is used to manage retrace distance when a partial match leads to a false match, KMP algorithm is very useful for applications that search relevant articles containing keywords from a large corpus of documents.

Example 14-8 illustrates a C-code example of using KMP substring searches.

Example 14-8. KMP Substring Search in C

```
// s1 is the target string of length cnt1
// s2 is the reference string of length cnt2
// j is the offset in target string s1 to start each round of string comparison
// i is the offset in reference string s2 to perform byte granular comparison
(continue)

int str_kmp_c(const char* s1, int cnt1, const char* s2, int cnt2 )
{ int i, j;
  i = 0; j = 0;
  while ( i+j < cnt1) {
    if( s2[i] == s1[i+j]) {
      i++;
      if( i == cnt2) break; // found full match
    }
    else {
      j = j+i - overlap_tbl[i]; // update the offset in s1 to start next round of string compare
      if( i > 0) {
        i = overlap_tbl[i]; // update the offset of s2 for next string compare should start at
      }
    }
  }
  return j;
}
```

1. Donald E. Knuth, James H. Morris, and Vaughan R. Pratt; SIAM J. Comput. Volume 6, Issue 2, pp. 323-350 (1977)

Example 14-8. KMP Substring Search in C (Contd.)

```

void kmp_precalc(const char * s2, int cnt2)
{int i = 2;
char nch = 0;
  overlap_tbl[0] = -1; overlap_tbl[1] = 0;
  // pre-calculate KMP table
  while( i < cnt2) {
    if( s2[i-1] == s2[nch]) {
      overlap_tbl[i] = nch +1;
      i++; nch++;
    }
    else if ( nch > 0) nch = overlap_tbl[nch];
    else {
      overlap_tbl[i] = 0;
      i++;
    }
  }
  overlap_tbl[cnt2] = 0;
}

```

Example 14-8 also includes the calculation of the KMP overlap table. Typical usage of KMP algorithm involves multiple invocation of the same reference string, so the overhead of precalculating the overlap table is easily amortized. When a false match is determined at offset *i* of the reference string, the overlap table will predict where the next round of string comparison should start (updating the offset *j*), and the offset in the reference string that byte-granular character comparison should resume/restart.

While KMP algorithm provides efficiency improvement over brute-force byte-granular substring search, its best performance is still limited by the number of byte-granular operations. To demonstrate the versatility and built-in lexical capability of PCMPISTRI, we show an SSE4.2 implementation of substring search using brute-force 16-byte granular approach in Example 14-9, and combining KMP overlap table with substring search using PCMPISTRI in Example 14-10.

Example 14-9. Brute-Force Substring Search Using PCMPISTRI Intrinsic

```

int strsubs_sse4_2i(const char* s1, int cnt1, const char* s2, int cnt2 )
{ int kpm_i=0, idx;
int ln1= 16, ln2=16, rcnt1 = cnt1, rcnt2= cnt2;
__m128i *p1 = (__m128i *) s1;
__m128i *p2 = (__m128i *) s2;
__m128ifrag1, frag2;
int cmp, cmp2, cmp_s;
__m128i *pt = NULL;
  if( cnt2 > cnt1 || !cnt1) return -1;
  frag1 = _mm_loadu_si128(p1); // load up to 16 bytes of fragment
  frag2 = _mm_loadu_si128(p2); // load up to 16 bytes of fragment

```

(continue)

Example 14-9. Brute-Force Substring Search Using PCMPISTRI Intrinsic (Contd.)

```

while(rcnt1 > 0)
{
    cmp_s = _mm_cmpestrs(frag2, (rcnt2>ln2)? ln2: rcnt2, frag1, (rcnt1>ln1)? ln1: rcnt1, 0x0c);
    cmp = _mm_cmpestri(frag2, (rcnt2>ln2)? ln2: rcnt2, frag1, (rcnt1>ln1)? ln1: rcnt1, 0x0c);
    if( !cmp) { // we have a partial match that needs further analysis
        if( cmp_s) { // if we're done with s2
            if( pt)
                {idx = (int) ((char *) pt - (char *) s1); }
            else
                {idx = (int) ((char *) p1 - (char *) s1); }
            return idx;
        }
    }

    // we do a round of string compare to verify full match till end of s2
    if( pt == NULL) pt = p1;
    cmp2 = 16;
    rcnt2 = cnt2 - 16 -(int) ((char *)p2-(char *)s2);
    while( cmp2 == 16 && rcnt2) { // each 16B frag matches,
        rcnt1 = cnt1 - 16 -(int) ((char *)p1-(char *)s1);
        rcnt2 = cnt2 - 16 -(int) ((char *)p2-(char *)s2);
        if( rcnt1 <=0 || rcnt2 <= 0 ) break;
        p1 = (__m128i *)(((char *)p1) + 16);
        p2 = (__m128i *)(((char *)p2) + 16);
        frag1 = _mm_loadu_si128(p1); // load up to 16 bytes of fragment
        frag2 = _mm_loadu_si128(p2); // load up to 16 bytes of fragment
        cmp2 = _mm_cmpestri(frag2, (rcnt2>ln2)? ln2: rcnt2, frag1, (rcnt1>ln1)? ln1: rcnt1, 0x18); // lsb, eq each
    };
    if( !rcnt2 || rcnt2 == cmp2) {
        idx = (int) ((char *) pt - (char *) s1);
        return idx;
    }
    else if ( rcnt1 <= 0) { // also cmp2 < 16, non match
        if( cmp2 == 16 && ((rcnt1 + 16) >= (rcnt2+16) ) )
            {idx = (int) ((char *) pt - (char *) s1);
            return idx;
            }
        else return -1;
    }
}
(continue)

```

Example 14-9. Brute-Force Substring Search Using PCMPISTRI Intrinsic (Contd.)

```

else { // in brute force, we advance fragment offset in target string s1 by 1
    p1 = (__m128i *)(((char *)pt) + 1); // we're not taking advantage of kmp
    rcnt1 = cnt1 - (int) ((char *)p1 - (char *)s1);
    pt = NULL;
    p2 = (__m128i *)((char *)s2);
    rcnt2 = cnt2 - (int) ((char *)p2 - (char *)s2);
    frag1 = _mm_loadu_si128(p1); // load next fragment from s1
    frag2 = _mm_loadu_si128(p2); // load up to 16 bytes of fragment
}
}
else{
    if( cmp == 16) p1 = (__m128i *)(((char *)p1) + 16);
    else p1 = (__m128i *)(((char *)p1) + cmp);
    rcnt1 = cnt1 - (int) ((char *)p1 - (char *)s1);
    if( pt && cmp ) pt = NULL;
    frag1 = _mm_loadu_si128(p1); // load next fragment from s1
}
}
return idx;
}

```

In Example 14-9, address adjustment using a constant to minimize loop-carry dependency is practised in two places:

- In the inner while loop of string comparison to determine full match or false match (the result `cmp2` is not used for address adjustment to avoid dependency).
- In the last code block when the outer loop executed `PCMPISTRI` to compare 16 sets of ordered compare between a target fragment with the first 16-byte fragment of the reference string, and all 16 ordered compare operations produced false result (producing `cmp` with a value of 16).

Example 14-10 shows an equivalent intrinsic implementation of substring search using SSE4.2 and KMP overlap table. When the inner loop of string comparison determines a false match, the KMP overlap table is consulted to determine the address offset for the target string fragment and the reference string fragment to minimize retrace.

It should be noted that a significant portions of retrace with retrace distance less than 15 bytes are avoided even in the brute-force SSE4.2 implementation of Example 14-9. This is due to the order-compare primitive of `PCMPISTRI`. "Ordered compare" performs 16 sets of string fragment compare, and many false match with less than 15 bytes of partial matches can be filtered out in the same iteration that executed `PCMPISTRI`.

Retrace distance of greater than 15 bytes does not get filtered out by the Example 14-9. By consulting with the KMP overlap table, Example 14-10 can eliminate retraces of greater than 15 bytes.

Example 14-10. Substring Search Using PCMPISTRI and KMP Overlap Table

```

int strkmp_sse4_2(const char* s1, int cnt1, const char* s2, int cnt2 )
{ int kpm_i=0, idx;
  int ln1= 16, ln2=16, rcnt1 = cnt1, rcnt2= cnt2;
  __m128i *p1 = (__m128i *) s1;
  __m128i *p2 = (__m128i *) s2;
  __m128i frag1, frag2;
    (continue)

```

Example 14-10. Substring Search Using PCMPISTRI and KMP Overlap Table (Contd.)

```

int cmp, cmp2, cmp_s;
__m128i *pt = NULL;
if( cnt2 > cnt1 || !cnt1) return -1;
frag1 = _mm_loadu_si128(p1); // load up to 16 bytes of fragment
frag2 = _mm_loadu_si128(p2); // load up to 16 bytes of fragment

while(rcnt1 > 0)
{
    cmp_s = _mm_cmpestrs(frag2, (rcnt2>ln2)? ln2: rcnt2, frag1, (rcnt1>ln1)? ln1: rcnt1, 0x0c);
    cmp = _mm_cmpestri(frag2, (rcnt2>ln2)? ln2: rcnt2, frag1, (rcnt1>ln1)? ln1: rcnt1, 0x0c);
    if( !cmp) { // we have a partial match that needs further analysis
        if( cmp_s) { // if we've reached the end with s2
            if( pt)
                {idx = (int) ((char *) pt - (char *) s1); }
            else
                {idx = (int) ((char *) p1 - (char *) s1); }
            return idx;
        }
        // we do a round of string compare to verify full match till end of s2
        if( pt == NULL) pt = p1;
        cmp2 = 16;
        rcnt2 = cnt2 - 16 - (int) ((char *) p2 - (char *) s2);

        while( cmp2 == 16 && rcnt2) { // each 16B frag matches
            rcnt1 = cnt1 - 16 - (int) ((char *) p1 - (char *) s1);
            rcnt2 = cnt2 - 16 - (int) ((char *) p2 - (char *) s2);
            if( rcnt1 <= 0 || rcnt2 <= 0 ) break;
            p1 = (__m128i *)(((char *) p1) + 16);
            p2 = (__m128i *)(((char *) p2) + 16);
            frag1 = _mm_loadu_si128(p1); // load up to 16 bytes of fragment
            frag2 = _mm_loadu_si128(p2); // load up to 16 bytes of fragment
            cmp2 = _mm_cmpestri(frag2, (rcnt2>ln2)? ln2: rcnt2, frag1, (rcnt1>ln1)? ln1: rcnt1, 0x18); // lsb, eq each
        };
        if( !rcnt2 || rcnt2 == cmp2) {
            idx = (int) ((char *) pt - (char *) s1);
            return idx;
        }
        else if ( rcnt1 <= 0 ) { // also cmp2 < 16, non match
            return -1;
        }
    }
    (continue)
}

```

Example 14-10. Substring Search Using PCMPISTRI and KMP Overlap Table (Contd.)

```

else { // a partial match led to false match, consult KMP overlap table for addr adjustment
    kpm_i = (int) ((char *)p1 - (char *)pt) + cmp2 ;
    p1 = (__m128i *)(((char *)pt) + (kpm_i - overlap_tbl[kpm_i])); // use kmp to skip retrace
    rcnt1 = cnt1 - (int) ((char *)p1 - (char *)s1);
    pt = NULL;
    p2 = (__m128i *)(((char *)s2) + (overlap_tbl[kpm_i]));
    rcnt2 = cnt2 - (int) ((char *)p2 - (char *)s2);
    frag1 = _mm_loadu_si128(p1); // load next fragment from s1
    frag2 = _mm_loadu_si128(p2); // load up to 16 bytes of fragment
}
}
else{
    if( kpm_i && overlap_tbl[kpm_i] ) {
        p2 = (__m128i *)(((char *)s2) );
        frag2 = _mm_loadu_si128(p2); // load up to 16 bytes of fragment
        //p1 = (__m128i *)(((char *)p1) );

        //rcnt1 = cnt1 - (int) ((char *)p1 - (char *)s1);
        if( pt && cmp ) pt = NULL;
        rcnt2 = cnt2 ;
        //frag1 = _mm_loadu_si128(p1); // load next fragment from s1
        frag2 = _mm_loadu_si128(p2); // load up to 16 bytes of fragment
        kpm_i = 0;
    }
    else { // equ order comp resulted in sub-frag match or non-match
        if( cmp == 16 ) p1 = (__m128i *)(((char *)p1) + 16);
        else p1 = (__m128i *)(((char *)p1) + cmp);
        rcnt1 = cnt1 - (int) ((char *)p1 - (char *)s1);
        if( pt && cmp ) pt = NULL;
        frag1 = _mm_loadu_si128(p1); // load next fragment from s1
    }
}
}
return idx;
}

```

The relative speed up of byte-granular KMP, brute-force SSE4.2, and SSE4.2 with KMP overlap table over byte-granular brute-force substring search is illustrated in the graph that plots relative speedup over percentage of retrace for a reference string of 55 bytes long. A retrace of 40% in the graph meant, after a partial match of the first 22 characters, a false match is determined.

So when brute-force, byte-granular code has to retrace, the other three implementation may be able to avoid the need to retrace because:

- Example 14-8 can use KMP overlap table to predict the start offset of next round of string compare operation after a partial-match/false-match, but forward movement after a first-character-false-match is still byte-granular.

- Example 14-9 can avoid retrace of shorter than 15 bytes but will be subject to retrace of 21 bytes after a partial-match/false-match at byte 22 of the reference string. Forward movement after each order-compare-false-match is 16 byte granular.
- Example 14-10 avoids retrace of 21 bytes after a partial-match/false-match, but KMP overlap table lookup incurs some overhead. Forward movement after each order-compare-false-match is 16 byte granular.

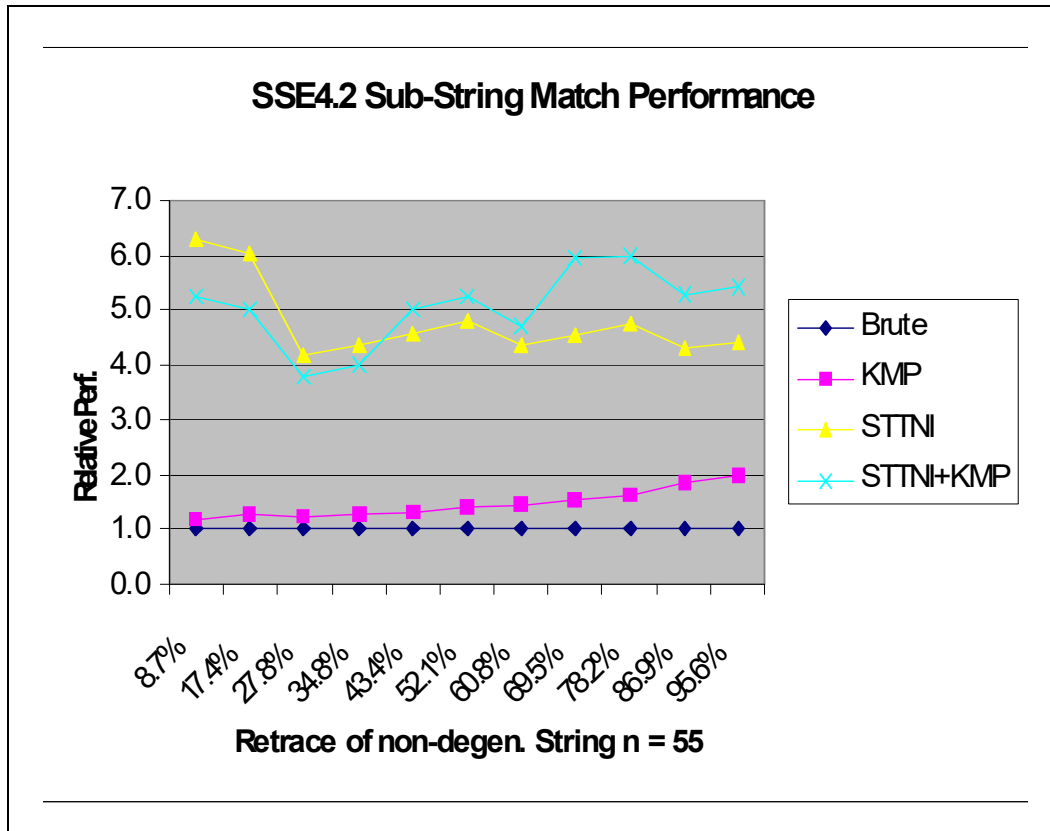

Figure 14-3. SSE4.2 Speedup of SubString Searches

14.3.4 String Token Extraction and Case Handling

Token extraction is a common task in text/string handling. It is one of the foundation of implementing lexer/parser objects of higher sophistication. Indexing services also build on tokenization primitives to sort text data from streams.

Tokenization requires the flexibility to use an array of delimiter characters.

A library implementation of `Strtok_s()` may employ a table-lookup technique to consolidate sequential comparisons of the delimiter characters into one comparison (similar to Example 14-6). An SSE4.2 implementation of the equivalent functionality of `strtok_s()` using intrinsic is shown in Example 14-11.

Example 14-11. Equivalent Strtok_s() Using PCMPISTRI Intrinsic

```

char ws_map8[32]; // packed bit lookup table for delimiter characters

char * strtok_sse4_2i(char* s1, char *sdlm, char ** pCtxt)
{
    __m128i *p1 = (__m128i *) s1;
    __m128ifrag1, stmpz, stmp1;
    int cmp_z, jj =0;
    int start, endtok, s_idx, ldx;
    if (sdlm == NULL || pCtxt == NULL) return NULL;
    if ( p1 == NULL && *pCtxt == NULL) return NULL;
    if ( s1 == NULL) {
        if( *pCtxt[0] == 0) { return NULL; }
        p1 = (__m128i *) *pCtxt;
        s1 = *pCtxt;
    }
    else p1 = (__m128i *) s1;
    memset(&ws_map8[0], 0, 32);
    while (sdlm[jj] ) {
        ws_map8[ (sdlm[jj] >> 3) ] |= (1 << (sdlm[jj] & 7) ); jj ++
    }
    frag1 = _mm_loadu_si128(p1); // load up to 16 bytes of fragment
    stmpz = _mm_loadu_si128((__m128i *)sdelimiter);
    // if the first char is not a delimiter , proceed to check non-delimiter,
    // otherwise need to skip leading delimiter chars
    if( ws_map8[s1[0]>>3] & (1 << (s1[0]&7)) ) {
        start = s_idx = _mm_cmpistri(stmpz, frag1, 0x10); // unsigned bytes/equal any, invert, lsb
    }
    else start = s_idx = 0;

    // check if we're dealing with short input string less than 16 bytes
    cmp_z = _mm_cmpistrz(stmpz, frag1, 0x10);
    if( cmp_z) { // last fragment
        if( !start) {
            endtok = ldx = _mm_cmpistri(stmpz, frag1, 0x00);
            if( endtok == 16) { // didn't find delimiter at the end, since it's null-terminated
                // find where is the null byte
                *pCtxt = s1+ 1+ _mm_cmpistri(frag1, frag1, 0x40);
                return s1;
            }
        }
        else { // found a delimiter that ends this word
            s1[start+endtok] = 0;
            *pCtxt = s1+start+endtok+1;
        }
    }
}
    (continue)

```

Example 14-11. | Equivalent Strtok_s() Using PCMPISTRI Intrinsic (Contd.)

```

else {
    if(!s1[start]){
        *pCtxt = s1 + start + 1;
        return NULL;
    }
    p1 = (__m128i *)(((char *)p1) + start);
    frag1 = _mm_loadu_si128(p1); // load up to 16 bytes of fragment
    endtok = idx = _mm_cmpistri(stmpz, frag1, 0x00); // unsigned bytes/equal any, lsb
    if( endtok == 16) { // looking for delimiter, found none
        *pCtxt = (char *)p1 + 1 + _mm_cmpistri(frag1, frag1, 0x40);
        return s1+start;
    }
    else { // found delimiter before null byte
        s1[start+endtok] = 0;
        *pCtxt = s1+start+endtok+1;
    }
}
}

else
{ while ( !cmp_z && s_idx == 16) {
    p1 = (__m128i *)(((char *)p1) + 16);
    frag1 = _mm_loadu_si128(p1); // load up to 16 bytes of fragment
    s_idx = _mm_cmpistri(stmpz, frag1, 0x10); // unsigned bytes/equal any, invert, lsb
    cmp_z = _mm_cmpistrz(stmpz, frag1, 0x10);
}
if(s_idx != 16) start = ((char *) p1 -s1) + s_idx;
else { // corner case if we ran to the end looking for delimiter and never found a non-dilimiter
    *pCtxt = (char *)p1 + 1 + _mm_cmpistri(frag1, frag1, 0x40);
    return NULL;
}
if( !s1[start] ) { // in case a null byte follows delimiter chars
    *pCtxt = s1 + start+1;
    return NULL;
}
// now proceed to find how many non-delimiters are there
p1 = (__m128i *)(((char *)p1) + s_idx);
frag1 = _mm_loadu_si128(p1); // load up to 16 bytes of fragment
endtok = idx = _mm_cmpistri(stmpz, frag1, 0x00); // unsigned bytes/equal any, lsb
cmp_z = 0;
while ( !cmp_z && idx == 16) {
    p1 = (__m128i *)(((char *)p1) + 16);
    frag1 = _mm_loadu_si128(p1); // load up to 16 bytes of fragment
    idx = _mm_cmpistri(stmpz, frag1, 0x00); // unsigned bytes/equal any, lsb
    cmp_z = _mm_cmpistrz(stmpz, frag1, 0x00);
    if(cmp_z) { endtok += idx; }
}
    (continue)

```

Example 14-11. | Equivalent Strtok_s() Using PCMPISTRI Intrinsic (Contd.)

```

if( cmp_z ){ // reached the end of s1
    if( ldx < 16) // end of word found by finding a delimiter
        endtok += ldx;
    else { // end of word found by finding the null
        if( s1[start+endtok]) // ensure this frag don't start with null byte
            endtok += 1+ _mm_cmpistri(frag1, frag1, 0x40);
    }
}
*pCtxt = s1+start+endtok+1;
s1[start+endtok] = 0;
}
return (char *) (s1+ start);
}

```

An SSE4.2 implementation of the equivalent functionality ofstrupr() using intrinsic is shown in Example 14-12.

Example 14-12. | Equivalent Strupr() Using PCMPISTRM Intrinsic

```

static char uldelta[16]= {0x20, 0x20, 0x20, 0x20, 0x20, 0x20, 0x20, 0x20, 0x20, 0x20, 0x20, 0x20, 0x20, 0x20, 0x20, 0x20};
static char ranglc[6]= {0x61, 0x7a, 0x00, 0x00, 0x00, 0x00};
char *strup_sse4_2i( char* s1)
{int len = 0, res = 0;
__m128i *p1 = (__m128i *) s1;
__m128ifrag1, ranglo, rmask, stmpz, stmp1;
int cmp_c, cmp_z, cmp_s;
if( !s1[0]) return (char *) s1;
frag1 = _mm_loadu_si128(p1); // load up to 16 bytes of fragment
ranglo = _mm_loadu_si128((__m128i *)ranglc); // load up to 16 bytes of fragment
stmpz = _mm_loadu_si128((__m128i *)uldelta);

cmp_z = _mm_cmpistrz(ranglo, frag1, 0x44); // range compare, produce byte masks
while( !cmp_z)
{
    rmask = _mm_cmpistrm(ranglo, frag1, 0x44); // producing byte mask
    stmp1 = _mm_blendv_epi8(stmpz, frag1, rmask); // bytes of lc preserved, other bytes replaced by const
    stmp1 = _mm_sub_epi8(stmp1, stmpz); // bytes of lc becomes uc, other bytes are now zero
    stmp1 = _mm_blendv_epi8(frag1, stmp1, rmask); //bytes of lc replaced by uc, other bytes unchanged
    _mm_storeu_si128(p1, stmp1); //
    p1 = (__m128i *)(((char *)p1) + 16);
    frag1 = _mm_loadu_si128(p1); // load up to 16 bytes of fragment
    cmp_z = _mm_cmpistrz(ranglo, frag1, 0x44);
}
}

```

(continue)

Example 14-12. Equivalent Strupr() Using PCMPISTRM Intrinsic (Contd.)

```

if( *(char *)p1 == 0) return (char *) s1;
rmsk = _mm_cmpistrm(ranglo, frag1, 0x44); // byte mask, valid lc bytes are 1, all other 0
stmp1 = _mm_blendv_epi8(stmpz, frag1, rmsk); // bytes of lc continue, other bytes replaced by const
stmp1 = _mm_sub_epi8(stmp1, stmpz); // bytes of lc becomes uc, other bytes are now zero
stmp1 = _mm_blendv_epi8(frag1, stmp1, rmsk); //bytes of lc replaced by uc, other bytes unchanged
rmsk = _mm_cmpistrm(frag1, frag1, 0x44); // byte mask, valid bytes are 1, invalid bytes are zero
_mm_maskmoveu_si128(stmp1, rmsk, (char *) p1); //
return (char *) s1;
}

```

14.3.5 Unicode Processing and PCMPxSTRy

Unicode representation of string/text data is required for software localization. UTF-16 is a common encoding scheme for localized content. In UTF-16 representation, each character is represented by a code point. There are two classes of code points: 16-bit code points and 32-bit code points which consists of a pair of 16-bit code points in specified value range, the latter is also referred to as a surrogate pair.

A common technique in unicode processing uses a table-loop up method, which has the benefit of reduced branching. As a tutorial example we compare the analogous problem of determining properly-encoded UTF-16 string length using general purpose code with table-lookup vs. SSE4.2.

Example 14-13 lists the C code sequence to determine the number of properly-encoded UTF-16 code points (either 16-bit or 32-bit code points) in a unicode text block. The code also verifies if there are any improperly-encoded surrogate pairs in the text block.

Example 14-13. UTF16 VerStrlen() Using C and Table Lookup Technique

```

// This example demonstrates validation of surrogate pairs (32-bit code point) and
// tally the number of 16-bit and 32-bit code points in the text block
// Parameters: s1 is pointer to input utf-16 text block.
// pLen: store count of utf-16 code points
// return the number of 16-bit code point encoded in the surrogate range but do not form
// a properly encoded surrogate pair. if 0: s1 is a properly encoded utf-16 block,
// If return value >0 then s1 contains invalid encoding of surrogates

int u16vstrlen_c(const short* s1, unsigned * pLen)
{int i, j, cnt = 0, cnt_invl = 0, spcnt= 0;
 unsigned short cc, cc2;
 char flg[3];

 cc2 = cc = s1[0];
 // map each word in s1 into bit patterns of 0, 1 or 2 using a table lookup
 // the first half of a surrogate pair must be encoded between D800-DBFF and mapped as 2
 // the 2nd half of a surrogate pair must be encoded between DC00-DFFF and mapped as 1
 // regular 16-bit encodings are mapped to 0, except null code mapped to 3
 flg[1] = utf16map[cc];
 flg[0] = flg[1];
 if(!flg[1]) cnt ++;
 i = 1;

 (continue)

```

Example 14-13. UTF16 VerStrlen() Using C and Table Lookup Technique (Contd.)

```

while (cc2) // examine each non-null word encoding
{ cc2 = s1[i];
  flg[2] = utf16map[cc2];
  if( (flg[1] && flg[2] && (flg[1]-flg[2] == 1) ) )
  { spcnt ++; } // found a surrogate pair
  else if(flg[1] == 2 && flg[2] != 1)
  { cnt_invl += 1; } // orphaned 1st half
  else if( !flg[1] && flg[2] == 1)
  { cnt_invl += 1; } // orphaned 2nd half
  else
  { if(!flg[2]) cnt ++; // regular non-null code16-bit code point
    else ;
  }
  flg[0] = flg[1]; // save the pair sequence for next iteration
  flg[1] = flg[2];
  i++;
}
*pLen = cnt + spcnt;
return cnt_invl;
}

```

The VerStrlen() function for UTF-16 encoded text block can be implemented using SSE4.2.

Example 14-14 shows the listing of SSE4.2 assembly implementation and Example 14-15 shows the listing of SSE4.2 intrinsic listings of VerStrlen().

Example 14-14. Assembly Listings of UTF16 VerStrlen() Using PCMPISTRI

```

// complementary range values for detecting either halves of 32-bit UTF-16 code point
static short ssch0[16]= {0x1, 0xd7ff, 0xe000, 0xffff, 0, 0};
// complementary range values for detecting the 1st half of 32-bit UTF-16 code point
static short ssch1[16]= {0x1, 0xd7ff, 0xdc00, 0xffff, 0, 0};
// complementary range values for detecting the 2nd half of 32-bit UTF-16 code point
static short ssch2[16]= {0x1, 0xdbff, 0xe000, 0xffff, 0, 0};

```

```

int utf16slen_sse4_2a(const short* s1, unsigned * pLen)
{int len = 0, res = 0;
  _asm{
    mov  eax, s1
    movdquxmm2, ssch0 ; load range value to identify either halves
    movdquxmm3, ssch1 ; load range value to identify 1st half (0xd800 to 0xdbff)
    movdquxmm4, ssch2 ; load range value to identify 2nd half (0xdc00 to 0xdfff)
    xor  ecx, ecx
    xor  edx, edx; store # of 32-bit code points (surrogate pairs)
    xor  ebx, ebx; store # of non-null 16-bit code points
    xor  edi, edi ; store # of invalid word encodings

```

(continue)

Example 14-14. Assembly Listings of UTF16 VerStrlen() Using PCMPISTRI (Contd.)

```

_loopc:
shl  ecx, 1; pcmpistri with word processing return ecx in word granularity, multiply by 2 to get byte offset
add  eax, ecx
movdquxmm1, [eax]; load a string fragment of up to 8 words
pcmpistri xmm2, xmm1, 15h; unsigned words, ranges, invert, lsb index returned to ecx
; if there is a utf-16 null wchar in xmm1, zf will be set.
; if all 8 words in the comparison matched range,
; none of bits in the intermediate result will be set after polarity inversions,
; and ECX will return with a value of 8
jz   short _lstfrag; if null code, handle last fragment
; if ecx < 8, ecx point to a word of either 1st or 2nd half of a 32-bit code point
cmp  ecx, 8
jne  _chksp
add  ebx, ecx ; accumulate # of 16-bit non-null code points
mov  ecx, 8 ; ecx must be 8 at this point, we want to avoid loop carry dependency
jmp  _loopc

```

```

_chksp; this fragment has word encodings in the surrogate value range
add  ebx, ecx ; account for the 16-bit code points
shl  ecx, 1; pcmpistri with word processing return ecx in word granularity, multiply by 2 to get byte offset
add  eax, ecx
movdquxmm1, [eax]; ensure the fragment start with word encoding in either half
pcmpistri xmm3, xmm1, 15h; unsigned words, ranges, invert, lsb index returned to ecx
jz   short _lstfrag2; if null code, handle the last fragment
cmp  ecx, 0 ; properly encoded 32-bit code point must start with 1st half
jg   _invalidsp; some invalid s-p code point exists in the fragment
pcmpistri xmm4, xmm1, 15h; unsigned words, ranges, invert, lsb index returned to ecx
cmp  ecx, 1 ; the 2nd half must follow the first half
jne  _invalidsp
add  edx, 1; accumulate # of valid surrogate pairs
add  ecx, 1 ; we want to advance two words
jmp  _loopc
_invalidsp; the first word of this fragment is either the 2nd half or an un-paired 1st half
add  edi, 1 ; we have an invalid code point (not a surrogate pair)
mov  ecx, 1 ; advance one word and continue scan for 32-bit code points
jmp  _loopc
_lstfrag:
add  ebx, ecx ; account for the non-null 16-bit code points
_morept:
shl  ecx, 1; pcmpistri with word processing return ecx in word granularity, multiply by 2 to get byte offset
add  eax, ecx
mov  si, [eax]; need to check for null code
cmp  si, 0
je   _final
movdquxmm1, [eax]; load remaining word elements which start with either 1st/2nd half
pcmpistri xmm3, xmm1, 15h; unsigned words, ranges, invert, lsb index returned to ecx
_lstfrag2:
cmp  ecx, 0 ; a valid 32-bit code point must start from 1st half
jne  _invalidsp2
pcmpistri xmm4, xmm1, 15h; unsigned words, ranges, invert, lsb index returned to ecx
cmp  ecx, 1
jne  _invalidsp2
      (continue)

```

Example 14-14. Assembly Listings of UTF16 VerStrlen() Using PCMPISTRI (Contd.)

```

add  edx, 1
mov  ecx, 2
jmp  _morept
_invalidsp2:
add  edi, 1
mov  ecx, 1
jmp  _morept
_final:
add  edx, ebx; add # of 16-bit and 32-bit code points
mov  ecx, pLen; retrieve address of pointer provided by caller
mov  [ecx], edx; store result of string length to memory
mov  res, edi
}
return res;
}

```

Example 14-15. Intrinsic Listings of UTF16 VerStrlen() Using PCMPISTRI

```

int utf16slen_i(const short* s1, unsigned * pLen)
{int len = 0, res = 0;
__m128i *pF = (__m128i *)s1;
__m128iu32 = _mm_loadu_si128((__m128i *)ssch0);
__m128i u32a = _mm_loadu_si128((__m128i *)ssch1);
__m128i u32b = _mm_loadu_si128((__m128i *)ssch2);
__m128ifrag1;
int offset1 = 0, cmp, cmp_1, cmp_2;
intcnt_16 = 0, cnt_sp=0, cnt_invl= 0;
short *ps;
while (1) {
    pF = (__m128i *)(((short *)pF) + offset1);
    frag1 = _mm_loadu_si128(pF); // load up to 8 words
    // does frag1 contain either halves of a 32-bit UTF-16 code point?
    cmp = _mm_cmpistri(u32, frag1, 0x15); // unsigned bytes, equal order, lsb index returned to ecx

    if (_mm_cmpistrz(u32, frag1, 0x15)) // there is a null code in frag1
    { cnt_16 += cmp;
      ps = (((short *)pF) + cmp);
      while (ps[0])
      { frag1 = _mm_loadu_si128( (__m128i *)ps);
        cmp_1 = _mm_cmpistri(u32a, frag1, 0x15);
        if(!cmp_1)
        { cmp_2 = _mm_cmpistri(u32b, frag1, 0x15);
          if( cmp_2 ==1){ cnt_sp++; offset1 = 2;}
          else {cnt_invl++; offset1 = 1;}
        }
      }
      (continue)
    }
}

```

Example 14-15. Intrinsic Listings of UTF16 VerStrlen() Using PCMPISTRI (Contd.)

```

    else
    { cmp_2 = _mm_cmpistri(u32b, frag1, 0x15);
      if(!cmp_2) {cnt_invl++; offset1 = 1;}
      else {cnt_16++; offset1 = 1;}
    }
    ps = (((short *)ps) + offset1);
  }
  break;
}

if(cmp != 8) // we have at least some half of 32-bit utf-16 code points
{ cnt_16 += cmp; // regular 16-bit UTF16 code points
  pF = (__m128i *)(((short *)pF) + cmp);
  frag1 = _mm_loadu_si128(pF);
  cmp_1 = _mm_cmpistri(u32a, frag1, 0x15);
  if(!cmp_1)
  { cmp_2 = _mm_cmpistri(u32b, frag1, 0x15);
    if( cmp_2 ==1) { cnt_sp++; offset1 = 2;}
    else {cnt_invl++; offset1 = 1;}
  }
  else
  { cnt_invl++;
    offset1 = 1;
  }
}
else {
  offset1 = 8; // increment address by 16 bytes to handle next fragment
  cnt_16+= 8;
}
};
*pLen = cnt_16 + cnt_sp;
return cnt_invl;
}

```

14.3.6 Replacement String Library Function Using SSE4.2

Unaligned 128-bit SIMD memory access can fetch data cross page boundary, since system software manages memory access rights with page granularity.

Implementing a replacement string library function using SIMD instructions must not cause memory access violation. This requirement can be met by adding a small amounts of code to check the memory address of each string fragment. If a memory address is found to be within 16 bytes of crossing over to the next page boundary, string processing algorithm can fall back to byte-granular technique.

Example 14-16 shows an SSE4.2 implementation of strcmp() that can replace byte-granular implementation supplied by standard tools.

Example 14-16. Replacement String Library Strcmp Using SSE4.2

```

// return 0 if strings are equal, 1 if greater, -1 if less
int strcmp_sse4_2(const char *src1, const char *src2)
{
    int val;
    __asm{
        mov     esi, src1 ;
        mov     edi, src2
        mov     edx, -16 ; common index relative to base of either string pointer
        xor     eax, eax
    topofloop:
        add     edx, 16 ; prevent loop carry dependency
    next:
        lea     ecx, [esi+edx] ; address of fragment that we want to load
        and     ecx, 0x0fff ; check least significant 12 bits of addr for page boundary
        cmp     ecx, 0x0ff0
        jg     too_close_pgb ; branch to byte-granular if within 16 bytes of boundary
        lea     ecx, [edi+edx] ; do the same check for each fragment of 2nd string
        and     ecx, 0x0fff
        cmp     ecx, 0x0ff0
        jg     too_close_pgb
        movdqu  xmm2, BYTE PTR[esi+edx]
        movdqu  xmm1, BYTE PTR[edi+edx]
        pcmpestri xmm2, xmm1, 0x18 ; equal each
        ja     topofloop
        jnc    ret_tag
        add     edx, ecx ; ecx points to the byte offset that differ
    not_equal:
        movzx   eax, BYTE PTR[esi+edx]
        movzx   edx, BYTE PTR[edi+edx]
        cmp     eax, edx
        cmova   eax, ONE
        cmovb   eax, NEG_ONE
        jmp     ret_tag
    too_close_pgb:
        add     edx, 1 ; do byte granular compare
        movzx   ecx, BYTE PTR[esi+edx-1]
        movzx   ebx, BYTE PTR[edi+edx-1]
        cmp     ecx, ebx
        jne    inequality
        add     ebx, ecx
        jnz    next
        jmp     ret_tag
    inequality:
        cmovb   eax, NEG_ONE
        cmova   eax, ONE
        (continue)

```

Example 14-16. Replacement String Library Strcmp Using SSE4.2 (Contd.)

```

ret_tag:
    mov     [val], eax
    }
    return(val);
}

```

In Example 14-16, 8 instructions were added following the label “next” to perform 4KByte boundary checking of address that will be used to load two string fragments into registers. If either address is found to be within 16 bytes of crossing over to the next page, the code branches to byte-granular comparison path following the label “too_close_pgb”.

The return values of Example 14-16 uses the convention of returning 0, +1, -1 using CMOV. It is straight forward to modify a few instructions to implement the convention of returning 0, positive integer, negative integer.

14.4 SSE4.2 ENABLED NUMERICAL AND LEXICAL COMPUTATION

SSE4.2 can enable SIMD programming techniques to explore byte-granular computational problems that were considered unlikely candidates for using SIMD instructions. We consider a common library function `atol()` in its full 64-bit flavor of converting a sequence of alpha numerical characters within the range representable by the data type `__int64`.

There are several attributes of this string-to-integer problem that poses as difficult challenges for using prior SIMD instruction sets (before the introduction of SSE4.2) to accelerate the numerical computation aspect of string-to-integer conversions:

- Character subset validation: Each character in the input stream must be validated with respect to the character subset definitions and conform to data representation rules of white space, signs, numerical digits. SSE4.2 provides the perfect tools for character subset validation.
- State-dependent nature of character validation: While SIMD computation instructions can expedite the arithmetic operations of “multiply by 10 and add”, the arithmetic computation requires the input byte stream to consist of numerical digits only. For example, the validation of numerical digits, white-space, and the presence/absence of sign, must be validated in mid-stream. The flexibility of the SSE4.2 primitive can handle these state-dependent validation well.
- Additionally, exit condition to wrap up arithmetic computation can happen in mid-stream due to invalid characters, or due to finite representable range of the data type ($\sim 10^{19}$ for int64, no more than 10 non-zero-leading digits for int32) may lead one to believe this type data stream consisting of short bursts are not suited for exploring SIMD ISA and be content with byte-granular solutions.

Because of the character subset validation and state-dependent nature, byte-granular solutions of the standard library function tends to have a high start-up cost (for example, converting a single numerical digit to integer may take 50 or 60 cycles), and low throughput (each additional numeric digit in the input character stream may take 6-8 cycles per byte).

A high level pseudo-operation flow of implementing a library replacement of `atol()` is described in Example 14-17.

Example 14-17. High-level flow of Character Subset Validation for String Conversion

1. Check Early_Out Exit Conditions (e.g. first byte is not valid).
2. Check if 1st byte is white space and skip any additional leading white space.
3. Check for the presence of a sign byte.
4. Check the validity of the remaining byte stream if they are numeric digits.
5. If the byte stream starts with '0', skip all leading digits that are '0'.
6. Determine how many valid non-zero-leading numeric digits.
7. Convert up to 16 non-zero-leading digits to int64 value.
8. load up to the next 16 bytes safely and check for consecutive numeric digits
9. Normalize int64 value converted from the first 16 digits, according to # of remaining digits,
10. Check for out-of-bound results of normalized intermediate int64 value,
11. Convert remaining digits to int64 value and add to normalized intermediate result,
12. Check for out-of-bound final results.

Example 14-18 shows the code listing of an equivalent functionality of `atol()` capable of producing int64 output range. Auxiliary function and data constants are listed in Example 14-19.

Example 14-18. Intrinsic Listings of `atol()` Replacement Using `PCMPISTRI`

```

__int64 sse4i_atol(const char* s1)
{char *p = (char *) s1;
  int NegSgn = 0;
  __m128i mask0;
  __m128i value0, value1;
  __m128i w1, w1_l8, w1_u8, w2, w3 = _mm_setzero_si128();
  __int64 xxi;
  int index, cflag, sflag, zflag, oob=0;
  // check the first character is valid via lookup
  if ( (BtMLValDeclnt[ *p >> 3] & (1 << ((*p) & 7)) ) == 0) return 0;
  // if the first character is white space, skip remaining white spaces
  if (BtMLws[*p >>3] & (1 << ((*p) & 7)) )
  { p ++;
    value0 = _mm_loadu_si128 ((__m128i *) listws);
  skip_more_ws:
    mask0 = __m128i_strloadu_page_boundary (p);
    /* look for the 1st non-white space character */
    index = _mm_cmpistri (value0, mask0, 0x10);
    cflag = _mm_cmpistrb (value0, mask0, 0x10);
    sflag = _mm_cmpistrs (value0, mask0, 0x10);
    if( !sflag && !cflag)
    { p = (char *) ((size_t) p + 16);
      goto skip_more_ws;
    }
    else    p = (char *) ((size_t) p + index);
  }
}

```

(continue)

Example 14-18. Intrinsic Listings of atol() Replacement Using PCMPISTRI (Contd.)

```

if( *p == '-')
{ p++;
  NegSgn = 1;
}
else if( *p == '+') p++;

/* load up to 16 byte safely and check how many valid numeric digits we can do SIMD */
value0 = _mm_loadu_si128 ((__m128i *) rangenumint);
mask0 = __m128i_strloadu_page_boundary (p);
index = _mm_cmpistri (value0, mask0, 0x14);
zflag = _mm_cmpistrz (value0, mask0, 0x14);

/* index points to the first digit that is not a valid numeric digit */
if( !index) return 0;
else if (index == 16)
{ if( *p == '0') /* if all 16 bytes are numeric digits */
  { /* skip leading zero */
    value1 = _mm_loadu_si128 ((__m128i *) rangenumintzr);
    index = _mm_cmpistri (value1, mask0, 0x14);
    zflag = _mm_cmpistrz (value1, mask0, 0x14);
    while(index == 16 && !zflag)
    { p = ( char *) ((size_t) p + 16);
      mask0 = __m128i_strloadu_page_boundary (p);
      index = _mm_cmpistri (value1, mask0, 0x14);
      zflag = _mm_cmpistrz (value1, mask0, 0x14);
    }
    /* now the 1st digit is non-zero, load up to 16 bytes and update index */
    if( index < 16)
      p = ( char *) ((size_t) p + index);
    /* load up to 16 bytes of non-zero leading numeric digits */
    mask0 = __m128i_strloadu_page_boundary (p);
    /* update index to point to non-numeric character or indicate we may have more than 16 bytes */
    index = _mm_cmpistri (value0, mask0, 0x14);
  }
}
if( index == 0) return 0;
else if( index == 1) return (NegSgn? (long long) -(p[0]-48): (long long) (p[0]-48));
// Input digits in xmm are ordered in reverse order. the LS digit of output is next to eos
// least sig numeric digit aligned to byte 15 , and subtract 0x30 from each ascii code
mask0 = ShfLAlnLSByte( mask0, 16 -index);
w1_u8 = _mm_slli_si128 ( mask0, 1);
w1 = _mm_add_epi8( mask0, _mm_slli_epi16 (w1_u8, 3)); /* mul by 8 and add */
w1 = _mm_add_epi8( w1, _mm_slli_epi16 (w1_u8, 1)); /* 7 LS bits per byte, in bytes 0, 2, 4, 6, 8, 10, 12, 14*/
w1 = _mm_srli_epi16( w1, 8); /* clear out upper bits of each wd*/
w2 = _mm_madd_epi16(w1, _mm_loadu_si128( (__m128i *) &MulplyPairBaseP2[0])); /* multiply base^2, add adjacent word*/
w1_u8 = _mm_packus_epi32 ( w2, w2); /* pack 4 low word of each dword into 63:0 */
w1 = _mm_madd_epi16(w1_u8, _mm_loadu_si128( (__m128i *) &MulplyPairBaseP4[0])); /* multiply base^4, add adjacent word*/
w1 = _mm_cvtepu32_epi64( w1); /* converted dw was in 63:0, expand to qw */
w1_l8 = _mm_mul_epu32(w1, _mm_setr_epi32( 100000000, 0, 0, 0));
w2 = _mm_add_epi64(w1_l8, _mm_srli_si128 (w1, 8));

```

(continue)

Example 14-18. Intrinsic Listings of atol() Replacement Using PCMPISTRI (Contd.)

```

if( index < 16)
{ xxi = _mm_extract_epi64(w2, 0);
  return (NegSgn? (long long) -xxi: (long long) xxi);
}
/* 64-bit integer allow up to 20 non-zero-leading digits. */
/* accumulate each 16-digit fragment*/
w3 = _mm_add_epi64(w3, w2);
/* handle next batch of up to 16 digits, 64-bit integer only allow 4 more digits */
p = ( char *) ((size_t) p + 16);
if( *p == 0)
{ xxi = _mm_extract_epi64(w2, 0);
  return (NegSgn? (long long) -xxi: (long long) xxi);
}
mask0 = __m128i_strloadu_page_boundary (p);
/* index points to first non-numeric digit */
index = _mm_cmpistri (value0, mask0, 0x14);
zflag = _mm_cmpistrz (value0, mask0, 0x14);
if( index == 0) /* the first char is not valid numeric digit */
{ xxi = _mm_extract_epi64(w2, 0);
  return (NegSgn? (long long) -xxi: (long long) xxi);
}
if ( index > 3) return (NegSgn? (long long) RINT64VALNEG: (long long) RINT64VALPOS);
/* multiply low qword by base^index */
w1 = _mm_mul_epu32( _mm_shuffle_epi32( w2, 0x50), _mm_setr_epi32( MulplyByBaseExpN
  [index - 1] , 0, MulplyByBaseExpN[index-1], 0));
w3 = _mm_add_epi64(w1, _mm_slli_epi64 ( _mm_srli_si128(w1, 8), 32 ) );
mask0 = ShfLAlnLSByte( mask0, 16 -index);
// convert upper 8 bytes of xmm: only least sig. 4 digits of output will be added to prev 16 digits
w1_u8 = _mm_cvtepi8_epi16(_mm_srli_si128 ( mask0, 8));
/* merge 2 digit at a time with multiplier into each dword*/
w1_u8 = _mm_madd_epi16(w1_u8, _mm_loadu_si128( (__m128i *) &MulplyQuadBaseExp3To0 [ 0]));
/* bits 63:0 has two dword integer, bits 63:32 is the LS dword of output; bits 127:64 is not needed*/
w1_u8 = _mm_cvtepu32_epi64( _mm_hadd_epi32(w1_u8, w1_u8) );
w3 = _mm_add_epi64(w3, _mm_srli_si128( w1_u8, 8) );
xxi = _mm_extract_epi64(w3, 0);
if( xxi >> 63)
  return (NegSgn? (long long) RINT64VALNEG: (long long) RINT64VALPOS);
else return (NegSgn? (long long) -xxi: (long long) xxi);
}

```

The general performance characteristics of an SSE4.2 enhanced atol() replacement have a start-up cost that is somewhat lower than byte-granular implementations generated from C code.

Example 14-19. Auxiliary Routines and Data Constants Used in sse4i_atol() listing

```

// bit lookup table of valid ascii code for decimal string conversion, white space, sign, numeric digits
static char BtMLValDeclnt[32] = {0x0, 0x3e, 0x0, 0x0, 0x1, 0x28, 0xff, 0x03,
0x0, 0x0, 0x0, 0x0, 0x0, 0x0, 0x0, 0x0,
0x0, 0x0, 0x0, 0x0, 0x0, 0x0, 0x0, 0x0,
0x0, 0x0, 0x0, 0x0, 0x0, 0x0, 0x0, 0x0};
(continue)

```

Example 14-19. Auxiliary Routines and Data Constants Used in sse4i_atol() listing (Contd.)

```

// bit lookup table, white space only
static char BtMLws[32] = {0x0, 0x3e, 0x0, 0x0, 0x1, 0x0, 0x0, 0x0,
0x0, 0x0, 0x0, 0x0, 0x0, 0x0, 0x0, 0x0,
0x0, 0x0, 0x0, 0x0, 0x0, 0x0, 0x0, 0x0,
0x0, 0x0, 0x0, 0x0, 0x0, 0x0, 0x0, 0x0};
// list of white space for sttni use
static char listws[16] =
    {0x20, 0x9, 0xa, 0xb, 0xc, 0xd, 0x0, 0x0, 0x0, 0x0, 0x0, 0x0, 0x0, 0x0, 0x0, 0x0};
// list of numeric digits for sttni use
static char rangenumint[16] =
    {0x30, 0x39, 0x0, 0x0, 0x0, 0x0, 0x0, 0x0, 0x0, 0x0, 0x0, 0x0, 0x0, 0x0, 0x0, 0x0};
static char rangenumintzr[16] =
    {0x30, 0x30, 0x0, 0x0, 0x0, 0x0, 0x0, 0x0, 0x0, 0x0, 0x0, 0x0, 0x0, 0x0, 0x0, 0x0};

// we use pmaddwd to merge two adjacent short integer pair, this is the second step of merging each pair of 2-digit
integers
static short MulpdyPairBaseP2[8] =
    { 100, 1, 100, 1, 100, 1, 100, 1};

// Multiplier-pair for two adjacent short integer pair, this is the third step of merging each pair of 4-digit integers
static short MulpdyPairBaseP4[8] =
    { 10000, 1, 10000, 1, 10000, 1, 10000, 1 };

// multiplier for pmulld for normalization of > 16 digits
static int MulpdyByBaseExpN[8] =
    { 10, 100, 1000, 10000, 100000, 1000000, 10000000, 100000000};

static short MulpdyQuadBaseExp3To0[8] =
    { 1000, 100, 10, 1, 1000, 100, 10, 1};

__m128i __m128i_shift_right (__m128i value, int offset)
{ switch (offset)
  {
    case 1: value = _mm_srli_si128 (value, 1); break;
    case 2: value = _mm_srli_si128 (value, 2); break;
    case 3: value = _mm_srli_si128 (value, 3); break;
    case 4: value = _mm_srli_si128 (value, 4); break;
    case 5: value = _mm_srli_si128 (value, 5); break;
    case 6: value = _mm_srli_si128 (value, 6); break;
    case 7: value = _mm_srli_si128 (value, 7); break;
    case 8: value = _mm_srli_si128 (value, 8); break;
    case 9: value = _mm_srli_si128 (value, 9); break;
    case 10: value = _mm_srli_si128 (value, 10); break;
    case 11: value = _mm_srli_si128 (value, 11); break;
    case 12: value = _mm_srli_si128 (value, 12); break;
    case 13: value = _mm_srli_si128 (value, 13); break;
    case 14: value = _mm_srli_si128 (value, 14); break;
    case 15: value = _mm_srli_si128 (value, 15); break;
  }
  return value;
}
    (continue)

```

Example 14-19. Auxiliary Routines and Data Constants Used in sse4i_atol() listing (Contd.)

```

/* Load string at S near page boundary safely. */
__m128i __m128i_strloadu_page_boundary (const char *s)
{
    int offset = ((size_t) s & (16 - 1));
    if (offset)
    {
        __m128i v = _mm_load_si128 ((__m128i *) (s - offset));
        __m128i zero = _mm_setzero_si128 ();
        int bmsk = _mm_movemask_epi8 (_mm_cmpeq_epi8 (v, zero));
        if ( (bmsk >> offset) != 0 ) return __m128i_shift_right (v, offset);
    }
    return _mm_loadu_si128 ((__m128i *) s);
}

__m128i ShfLAlnLSByte( __m128i value, int offset)
{
    /*now remove constant bias, so each byte element are unsigned byte int */
    value = _mm_sub_epi8(value, _mm_setr_epi32(0x30303030, 0x30303030, 0x30303030, 0x30303030));
    switch (offset)
    {
        case 1:
            value = _mm_slli_si128 (value, 1); break;
        case 2:
            value = _mm_slli_si128 (value, 2); break;
        case 3:
            value = _mm_slli_si128 (value, 3); break;
        case 4:
            value = _mm_slli_si128 (value, 4); break;
        case 5:
            value = _mm_slli_si128 (value, 5); break;
        case 6:
            value = _mm_slli_si128 (value, 6); break;
        case 7:
            value = _mm_slli_si128 (value, 7); break;
        case 8:
            value = _mm_slli_si128 (value, 8); break;
        case 9:
            value = _mm_slli_si128 (value, 9); break;
        case 10:
            value = _mm_slli_si128 (value, 10); break;
        case 11:
            value = _mm_slli_si128 (value, 11); break;
        case 12:
            value = _mm_slli_si128 (value, 12); break;
        case 13:
            value = _mm_slli_si128 (value, 13); break;
        case 14:
            value = _mm_slli_si128 (value, 14); break;
        case 15:
            value = _mm_slli_si128 (value, 15); break;
    }
    return value;
}

```

With an input byte stream no more than 16 non-zero-leading digits, it has a constant performance. An input string consisting of more than 16 bytes of non-zero-leading digits can be processed in about 100 cycles or less, compared byte-granular solution needing around 200 cycles. Even for shorter input strings of 9 non-zero-leading digits, SSE4.2 enhanced replacement can also achieve ~2X performance of byte-granular solutions.

14.5 NUMERICAL DATA CONVERSION TO ASCII FORMAT

Conversion of binary integer data to ASCII format gets used in many situations from simple C library functions to computations with finances. Some C libraries provides exported conversion functions like `itoa`, `ltoa`; other libraries implement internal equivalents to support data formatting needs of standard output functions. Among the most common binary integer to ascii conversion is conversion based on radix 10. Example 14-20 shows the basic technique implemented in many libraries for base 10 conversion to ascii of a 64-bit integer. For simplicity, the example produces lower-case output format.

Example 14-20. Conversion of 64-bit Integer to ASCII

```
// Convert 64-bit signed binary integer to lower-case ASCII format

static char lc_digits[] = "0123456789abcdefghijklmnopqrstuvwxyz";

int ltoa_cref( __int64 x, char* out)
{const char *digits = &lc_digits[0];
char lbuf[32] // base 10 conversion of 64-bit signed integer need only 21 digits
char * p_bkwd = &lbuf[2];
__int64 y;
unsigned int base = 10, len = 0, r, cnt;
if( x < 0)
{ y = -x;
while( y > 0)
{ r = (int)(y % base); // one digit at a time from least significant digit
y = y / base;
* --p_bkwd = digits[r];
len ++;
}
*out++ = '-';
cnt = len + 1;
while( len-- ) *out++ = p_bkwd++; // copy each converted digits
} else
{
y = x;
while( y > 0)
{ r = (int)(y % base); // one digit at a time from least significant digit
y = y / base;
* --p_bkwd = digits[r];
len ++;
}
cnt = len;;
while( len-- ) *out++ = p_bkwd++; // copy each converted digits
}
}
(continue)
```

Example 14-20. Conversion of 64-bit Integer to ASCII (Contd.)

```

out[cnt] = 0;
return (int) cnt;
}

```

Example 14-20 employs iterative sequence that process one digit at a time using the hardware native integer divide instruction. The reliance on integer divide can be replaced by fixed-point multiply technique discussed in Chapter 13. This is shown in Example 14-21.

Example 14-21. Conversion of 64-bit Integer to ASCII without Integer Division

```

// Convert 64-bit signed binary integer to lower-case ASCII format and
// replace integer division with fixed-point multiply
;__int64 umul_64x64(__int64* p128, __int64 u, __int64 v)
umul_64x64 PROC
    mov     rax, rdx ; 2nd parameter
    mul     r8 ; u * v
    mov     qword ptr [rcx], rax
    mov     qword ptr [rcx+8], rdx
    ret 0
umul_64x64 ENDP
#define cg_10_pms3 0xffffffffccccccdu11
static char lc_digits[] = "0123456789";

int lltoa_cref(__int64 x, char* out)
{const char *digits = &lc_digits[0];
char lbuf[32] // base 10 conversion of 64-bit signed integer need only 21 digits
char * p_bkwd = &lbuf[2];
__int64 y, z128[2];
unsigned __int64 q;
unsigned int base = 10, len = 0, r, cnt;

if( x < 0)
{ y = -x;
while (y > 0)
{ umul_64x64( &z128[0], y, cg_10_pms3);
q = z128[1] >> 3;
q = (y < q * (unsigned __int64) base)? q-1: q;
r = (int) (y - q * (unsigned __int64) base); // one digit at a time from least significant digit
y =q;
* --p_bkwd = digits[r];
len ++;
}
*out++ = '-';
cnt = len +1;
while( len--) *out++ = p_bkwd++; // copy each converted digits
} else
    (continue)

```

Example 14-21. Conversion of 64-bit Integer to ASCII without Integer Division (Contd.)

```

{
  y = x;
  while (y > 0)
  {
    umul_64x64( &z128[0], y, cg_10_pms3);
    q = z128[1] >> 3;
    q = (y < q * (unsigned __int64) base)? q-1: q;
    r = (int) (y - q * (unsigned __int64) base); // one digit at a time from least significant digit
    y = q;
    *--p_bkwd = digits[r];
    len++;
  }
  cnt = len;;
  while( len-- ) *out++ = p_bkwd++; // copy each converted digits
}
out[cnt] = 0;
return cnt;
}

```

Example 14-21 provides significant speed improvement by eliminating the reliance on integer divisions. However, the numeric format conversion problem is still constrained by the dependent chain that process one digit at a time.

SIMD technique can apply to this class of integer numeric conversion problem by noting that an unsigned 64-bit integer can expand a dynamic range of up to 20 digits. Such a wide dynamic range can be expressed as polynomial expressions of the form:

$$a_0 + a_1 * 10^4 + a_2 * 10^8 + a_3 * 10^{12} + a_4 * 10^{16} \text{ where}$$

the dynamic range of a_i is between $[0, 9999]$.

Reduction of an unsigned 64-bit integer into up-to 5 reduced-range coefficients can be computed using fixed-point multiply in stages. Once the dynamic range of coefficients are reduced to no more than 4 digits, one can apply SIMD techniques to compute ascii conversion in parallel.

The SIMD technique to convert an unsigned 16-bit integer via radix 10 with input dynamic range $[0, 9999]$ is shown in Figure 14-4. This technique can also be generalized to apply to other non-power-of-2 radix that is less than 16.

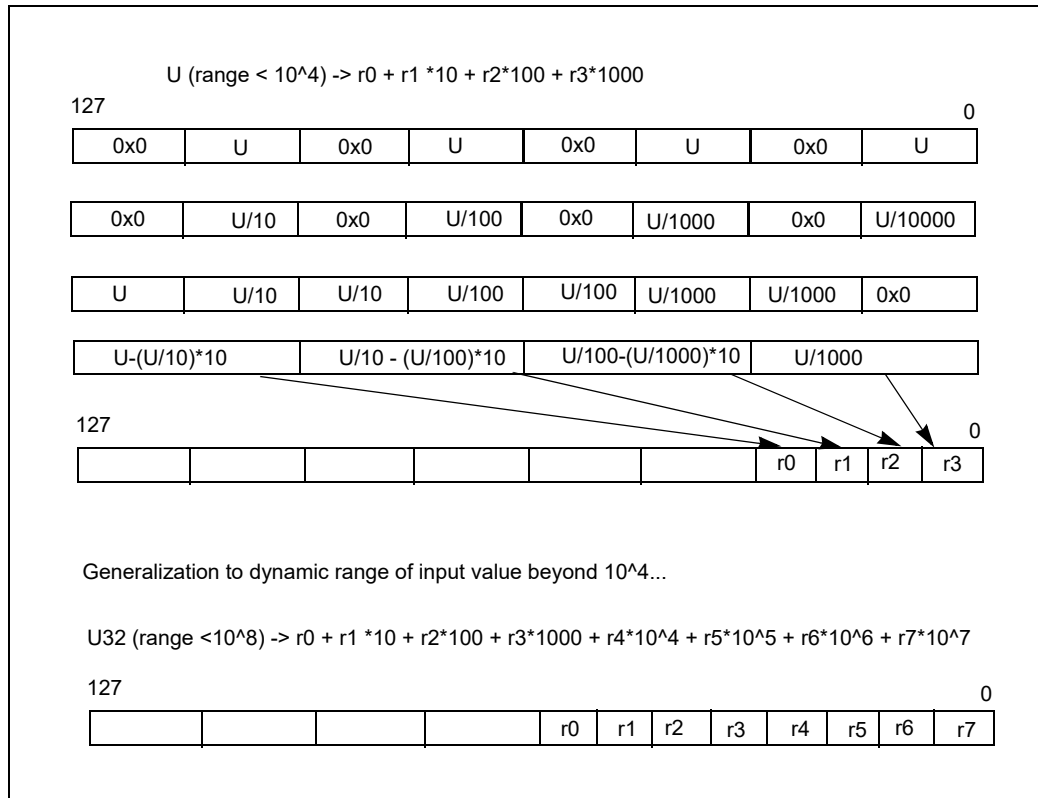

Figure 14-4. Compute Four Remainders of Unsigned Short Integer in Parallel

To handle greater input dynamic ranges, the input is reduced into multiple unsigned short integers and converted sequentially. The most significant U16 conversion is computed first, followed by the conversion of the next four significant digits.

Example 14-22 shows the fixed-point multiply combined with parallel remainder computation using SSE4 instructions for 64-bit integer conversion up to 19 digits.

Example 14-22. Conversion of 64-bit Integer to ASCII Using SSE4

```
#include <smmintrin.h>
#include <stdio.h>
#define QWCG10to8 0xabcc77118461cefdull
#define QWCONST10to8 100000000ull

/* macro to convert input parameter of short integer "hi4" into output variable "x3" which is __m128i;
the input value "hi4" is assume to be less than 10^4;
the output is 4 single-digit integer between 0-9, located in the low byte of each dword,
most significant digit in lowest DW.
implicit overwrites: locally allocated __m128i variable "x0", "x2"
*/
    (continue)
```

Example 14-22. Conversion of 64-bit Integer to ASCII Using SSE4 (Contd.)

```

#define __ParMod10to4SSSE3( x3, hi4 ) \
{
    x0 = _mm_shuffle_epi32( _mm_cvtsi32_si128( (hi4)), 0); \
    x2 = _mm_mulhi_epu16(x0, _mm_loadu_si128( (__m128i *) quoTenThsn_mulplr_d)); \
    x2 = _mm_srli_epi32( _mm_madd_epi16( x2, _mm_loadu_si128( (__m128i *) quo4digComp_mulplr_d), 10); \
    (x3) = _mm_insert_epi16(_mm_slli_si128(x2, 6), (int) (hi4), 1); \
    (x3) = _mm_or_si128(x2, (x3)); \
    (x3) = _mm_madd_epi16((x3), _mm_loadu_si128( (__m128i *) mten_mulplr_d )); \
}

```

/* macro to convert input parameter of the 3rd dword element of "t5" (__m128i type)
into output variable "x3" which is __m128i;
the third dword element "t5" is assume to be less than 10⁴, the 4th dword must be 0;
the output is 4 single-digit integer between 0-9, located in the low byte of each dword,
MS digit in LS DW.
implicit overwrites: locally allocated __m128i variable "x0", "x2"
*/

```

#define __ParMod10to4SSSE3v( x3, t5 ) \
{
    x0 = _mm_shuffle_epi32( t5, 0xaa); \
    x2 = _mm_mulhi_epu16(x0, _mm_loadu_si128( (__m128i *) quoTenThsn_mulplr_d)); \
    x2 = _mm_srli_epi32( _mm_madd_epi16( x2, _mm_loadu_si128( (__m128i *) quo4digComp_mulplr_d), 10); \
    (x3) = _mm_or_si128(_mm_slli_si128(x2, 6), _mm_srli_si128(t5, 6)); \
    (x3) = _mm_or_si128(x2, (x3)); \
    (x3) = _mm_madd_epi16((x3), _mm_loadu_si128( (__m128i *) mten_mulplr_d )); \
}

```

```

static __attribute__((aligned(16))) short quo4digComp_mulplr_d[8] =
{ 1024, 0, 64, 0, 8, 0, 0, 0};
static __attribute__((aligned(16))) short quoTenThsn_mulplr_d[8] =
{ 0x199a, 0, 0x28f6, 0, 0x20c5, 0, 0x1a37, 0};
static __attribute__((aligned(16))) short mten_mulplr_d[8] =
{ -10, 1, -10, 1, -10, 1, -10, 1};
static __attribute__((aligned(16))) unsigned short bcstpkldw[8] =
{0x080c, 0x0004, 0x8080, 0x8080, 0x8080, 0x8080, 0x8080, 0x8080};
static __attribute__((aligned(16))) unsigned short bcstpkdw1[8] =
{0x8080, 0x8080, 0x080c, 0x0004, 0x8080, 0x8080, 0x8080, 0x8080};
static __attribute__((aligned(16))) unsigned short bcstpkdw2[8] =
{0x8080, 0x8080, 0x8080, 0x8080, 0x080c, 0x0004, 0x8080, 0x8080};
static __attribute__((aligned(16))) unsigned short bcstpkdw3[8] =
{0x8080, 0x8080, 0x8080, 0x8080, 0x8080, 0x8080, 0x080c, 0x0004};
static __attribute__((aligned(16))) int ascObias[4] =
{0x30, 0x30, 0x30, 0x30};
static __attribute__((aligned(16))) int ascOreversebias[4] =
{0xd0d0d0d0, 0xd0d0d0d0, 0xd0d0d0d0, 0xd0d0d0d0};
static __attribute__((aligned(16))) int pr_cg_10to4[4] =
{ 0x68db8db, 0, 0x68db8db, 0};
static __attribute__((aligned(16))) int pr_1_m10to4[4] =
{ -10000, 0, 1, 0};

```

(continue)

Example 14-22. Conversion of 64-bit Integer to ASCII Using SSE4 (Contd.)

```

/*input value "xx" is less than 2^63-1 */
/* In environment that does not support binary integer arithmetic on __int128_t,
   this helper can be done as asm routine
*/
__inline __int64_t u64mod10to8( __int64_t * pLo, __int64_t xx)
{__int128_t t, b = (__int128_t)QWCG10to8;
 __int64_t q;
  t = b * (__int128_t)xx;
  q = t>>(64 +26); // shift count associated with QWCG10to8
  *pLo = xx - QWCONST10to8 * q;
  return q;
}

/* convert integer between 2^63-1 and 0 to ASCII string */
int sse4i_q2a_u63 ( __int64_t xx, char *ps)
{int j, tmp, idx=0, cnt;
 __int64_t lo8, hi8, abv16, temp;
 __m128i x0, m0, x1, x2, x3, x4, x5, x6, m1;
 long long w, u;
  if ( xx < 10000 )
  { j = ubs_Lt10k_2s_i2 ( (unsigned ) xx, ps);
    ps[j] = 0;    return j;
  }
  if (xx < 100000000) // dynamic range of xx is less than 32-bits
  { m0 = _mm_cvtsi32_si128( xx);
    x1 = _mm_shuffle_epi32(m0, 0x44); // broadcast to dw0 and dw2
    x3 = _mm_mul_epu32(x1, _mm_loadu_si128( (__m128i *) pr_cg_10to4 ));
    x3 = _mm_mullo_epi32(_mm_srli_epi64(x3, 40), _mm_loadu_si128( (__m128i *)pr_1_m10to4));
    m0 = _mm_add_epi32( _mm_srli_si128( x1, 8), x3); // quotient in dw2, remainder in dw0
    __ParMod10to4SSSE3v( x3, m0); // pack single digit from each dword to dw0
    x4 = _mm_shuffle_epi8(x3, _mm_loadu_si128( (__m128i *) bcstpklodw ));
    __ParMod10to4SSSE3v( x3, _mm_slli_si128(m0, 8)); // move the remainder to dw2 first
    x5 = _mm_shuffle_epi8(x3, _mm_loadu_si128( (__m128i *) bcstpkdw1 ));
    x4 = _mm_or_si128(x4, x5); // pack digits in bytes 0-7 with leading 0
    cnt = 8;
  }
  else
  { hi8 = u64mod10to8(&lo8, xx);
    if ( hi8 < 10000) // decompose lo8 dword into quotient and remainder mod 10^4
    { m0 = _mm_cvtsi32_si128( lo8);
      x2 = _mm_shuffle_epi32(m0, 0x44);
      x3 = _mm_mul_epu32(x2, _mm_loadu_si128( (__m128i *)pr_cg_10to4));
      x3 = _mm_mullo_epi32(_mm_srli_epi64(x3, 40), _mm_loadu_si128( (__m128i *)pr_1_m10to4));
      m0 = _mm_add_epi32( _mm_srli_si128( x2, 8), x3); // quotient in dw0
      __ParMod10to4SSSE3v( x3, hi8); // handle digist 11:8 first
      x4 = _mm_shuffle_epi8(x3, _mm_loadu_si128( (__m128i *) bcstpklodw ));
      __ParMod10to4SSSE3v( x3, m0); // handle digits 7:4
      x5 = _mm_shuffle_epi8(x3, _mm_loadu_si128( (__m128i *) bcstpkdw1 ));
      x4 = _mm_or_si128(x4, x5);
      __ParMod10to4SSSE3v( x3, _mm_slli_si128(m0, 8));
      x5 = _mm_shuffle_epi8(x3, _mm_loadu_si128( (__m128i *) bcstpkdw2 ));
      x4 = _mm_or_si128(x4, x5); // pack single digist in bytes 0-11 with leading 0
      cnt = 12;
    }
  }
}
  (continue)

```

Example 14-22. Conversion of 64-bit Integer to ASCII Using SSE4 (Contd.)

```

else
{
    cnt = 0;
    if ( hi8 >= 100000000) // handle input greater than 10^16
    {
        abv16 = u64mod10to8(&temp, (__int64_t)hi8);
        hi8 = temp;
        __ParMod10to4SSSE3( x3, abv16);
        x6 = _mm_shuffle_epi8(x3, _mm_loadu_si128( (__m128i *) bcstpklodw ));
        cnt = 4;
    } // start with handling digits 15:12
    m0 = _mm_cvtsi32_si128( hi8);
    x2 = _mm_shuffle_epi32(m0, 0x44);
    x3 = _mm_mul_epu32(x2, _mm_loadu_si128( (__m128i *)pr_cg_10to4));
    x3 = _mm_mullo_epi32(_mm_srli_epi64(x3, 40), _mm_loadu_si128( (__m128i *)pr_1_m10to4));
    m0 = _mm_add_epi32( _mm_srli_si128( x2, 8), x3);
    m1 = _mm_cvtsi32_si128( lo8);
    x2 = _mm_shuffle_epi32(m1, 0x44);
    x3 = _mm_mul_epu32(x2, _mm_loadu_si128( (__m128i *)pr_cg_10to4));
    x3 = _mm_mullo_epi32(_mm_srli_epi64(x3, 40), _mm_loadu_si128( (__m128i *)pr_1_m10to4));
    m1 = _mm_add_epi32( _mm_srli_si128( x2, 8), x3);
    __ParMod10to4SSSE3v( x3, m0);
    x4 = _mm_shuffle_epi8(x3, _mm_loadu_si128( (__m128i *) bcstpklodw ));
    __ParMod10to4SSSE3v( x3, _mm_slli_si128(m0, 8));
    x5 = _mm_shuffle_epi8(x3, _mm_loadu_si128( (__m128i *) bcstpkdw1 ));
    x4 = _mm_or_si128(x4, x5);
    __ParMod10to4SSSE3v( x3, m1);
    x5 = _mm_shuffle_epi8(x3, _mm_loadu_si128( (__m128i *) bcstpkdw2 ));
    x4 = _mm_or_si128(x4, x5);
    __ParMod10to4SSSE3v( x3, _mm_slli_si128(m1, 8));
    x5 = _mm_shuffle_epi8(x3, _mm_loadu_si128( (__m128i *) bcstpkdw3 ));
    x4 = _mm_or_si128(x4, x5);
    cnt += 16;
}
}
m0 = _mm_loadu_si128( (__m128i *) asc0reversebias);
if (cnt > 16)
{
    tmp = _mm_movemask_epi8( _mm_cmpgt_epi8(x6, _mm_setzero_si128()));
    x6 = _mm_sub_epi8(x6, m0);
} else {
    tmp = _mm_movemask_epi8( _mm_cmpgt_epi8(x4, _mm_setzero_si128()));
}
}

#ifdef __USE_GCC__
__asm__ ("bsfl %1, %%ecx; movl %%ecx, %0;" : "=r"(idx) : "r"(tmp) : "%ecx");
#else
_BitScanForward(&idx, tmp);
#endif
x4 = _mm_sub_epi8(x4, m0);
cnt -= idx;
w = _mm_cvtsi128_si64(x4);

switch(cnt)
{
    case 5: *ps++ = (char) (w >> 24); *(unsigned *) ps = (w >> 32);
        break;
    case 6: *(short *)ps = (short) (w >> 16); *(unsigned *) (&ps[2]) = (w >> 32);
        break;
    (continue)
}

```

Example 14-22. Conversion of 64-bit Integer to ASCII Using SSE4 (Contd.)

```

case7:*ps = (char) (w >>8); *(short *)(&ps[1]) = (short) (w >>16);
      *(unsigned *)(&ps[3]) = (w >>32);
      break;
case 8: *(long long *)ps = w;
      break;
case9:*ps++ = (char) (w >>24);
      *(long long *)(&ps[0]) = _mm_cvtsi128_si64( _mm_srli_si128(x4, 4));
      break;
case10:*(short *)ps = (short) (w >>16);
      *(long long *)(&ps[2]) = _mm_cvtsi128_si64( _mm_srli_si128(x4, 4));
      break;
case11:*ps = (char) (w >>8); *(short *)(&ps[1]) = (short) (w >>16);
      *(long long *)(&ps[3]) = _mm_cvtsi128_si64( _mm_srli_si128(x4, 4));
      break;
case 12: *(unsigned *)ps = w;
      *(long long *)(&ps[4]) = _mm_cvtsi128_si64( _mm_srli_si128(x4, 4));
      break;
case13:*ps++ = (char) (w >>24); *(unsigned *) ps = (w >>32);
      *(long long *)(&ps[4]) = _mm_cvtsi128_si64( _mm_srli_si128(x4, 8));
      break;
case14:*(short *)ps = (short) (w >>16); *(unsigned *)(&ps[2]) = (w >>32);
      *(long long *)(&ps[6]) = _mm_cvtsi128_si64( _mm_srli_si128(x4, 8));
      break;
case15: *ps = (char) (w >>8);
      *(short *)(&ps[1]) = (short) (w >>16); *(unsigned *)(&ps[3]) = (w >>32);
      *(long long *)(&ps[7]) = _mm_cvtsi128_si64( _mm_srli_si128(x4, 8));
      break;
case 16: _mm_storeu_si128( (__m128i *) ps, x4);
      break;

case17:u = _mm_cvtsi128_si64(x6); *ps++ = (char) (u >>24);
      _mm_storeu_si128( (__m128i *) &ps[0], x4);
      break;
case18:u = _mm_cvtsi128_si64(x6); *(short *)ps = (short) (u >>16);
      _mm_storeu_si128( (__m128i *) &ps[2], x4);
      break;
case19:u = _mm_cvtsi128_si64(x6); *ps = (char) (u >>8);
      *(short *)(&ps[1]) = (short) (u >>16);
      _mm_storeu_si128( (__m128i *) &ps[3], x4);
      break;
case20:u = _mm_cvtsi128_si64(x6); *(unsigned *)ps = (short) (u);
      _mm_storeu_si128( (__m128i *) &ps[4], x4);
      break;
}
return cnt;
}

```

(continue)

Example 14-22. Conversion of 64-bit Integer to ASCII Using SSE4 (Contd.)

```

/* convert input value into 4 single digits via parallel fixed-point arithmetic with each dword
   element, and pack each digit into low dword element and write to buffer without leading
   white space; input value must be < 10000 and > 9
*/
__inline int ubs_Lt10k_2s_i2(int x_Lt10k, char *ps)
{int tmp;
 __m128i x0, m0, x2, x3, x4, compv;
// Use a set of scaling constant to compensate for lack for per-element shift count
  compv = __mm_loadu_si128( (__m128i *) quo4digComp_mulplr_d);
// broadcast input value to each dword element
  x0 = _mm_shuffle_epi32( _mm_cvtsi32_si128( x_Lt10k), 0);
// low to high dword in x0 : u16, u16, u16, u16
  m0 = _mm_loadu_si128( (__m128i *) quoTenThsn_mulplr_d); // load 4 congruent consts
  x2 = _mm_mulhi_epu16(x0, m0); // parallel fixed-point multiply for base 10,100, 1000, 10000
  x2 = _mm_srli_epi32( _mm_madd_epi16( x2, compv), 10);
// dword content in x2: u16/10, u16/100, u16/1000, u16/10000
  x3 = _mm_insert_epi16(_mm_slli_si128(x2, 6), (int) x_Lt10k, 1);
//word content in x3: 0, u16, 0, u16/10, 0, u16/100, 0, u16/1000

  x4 = _mm_or_si128(x2, x3);
// perform parallel remainder operation with each word pair to derive 4 unbiased single-digit result
  x4 = _mm_madd_epi16(x4, _mm_loadu_si128( (__m128i *) mten_mulplr_d) );
  x2 = _mm_add_epi32( x4, _mm_loadu_si128( (__m128i *) ascObias) );
// pack each ascii-biased digits from respective dword to the low dword element
  x3 = _mm_shuffle_epi8(x2, _mm_loadu_si128( (__m128i *) bcstpkldw) );

// store ascii result to buffer without leading white space
if (x_Lt10k > 999)
{ *(int *) ps = _mm_cvtsi128_si32( x3);
  return 4;
}
else if (x_Lt10k > 99)
{ tmp = _mm_cvtsi128_si32( x3);
  *ps = (char ) (tmp >>8);
  *((short *) (++ps)) = (short ) (tmp >>16);
  return 3;
}
else if ( x_Lt10k > 9) // take advantage of reduced dynamic range > 9 to reduce branching
{ *((short *) ps) = (short) _mm_extract_epi16( x3, 1);
  return 2;
}
*ps = '0' + x_Lt10k;
return 1;
}

```

(continue)

Example 14-22. Conversion of 64-bit Integer to ASCII Using SSE4 (Contd.)

```

char lower_digits[] = "0123456789";

int ltoa_sse4 (const long long s1, char * buf)
{long long temp ;
int j = 1, len = 0;
const char *digits = &lower_digits[0];
  if( s1 < 0) {
    temp = -s1;
    len ++;
    beg[0] = '-';
    if( temp < 10) beg[1] = digits[ (int) temp];
    else len += sse4i_q2a_u63( temp, &buf[ 1]); // parallel conversion in 4-digit granular operation
  }
  else {
    if( s1 < 10) beg[ 0] = digits[(int)s1];
    else len += sse4i_q2a_u63( s1, &buf[ 1] );
  }
  buf[len] = 0;
  return len;
}

```

When an ltoa()-like utility implementation executes native IDIV instruction to convert one digit at a time, it can produce output at a speed of about 45-50 cycles per digit. Using fixed-point multiply to replace IDIV (like Example 14-21) can reduce 10-15 cycles per digit. Using 128-bit SIMD technique to perform parallel fixed-point arithmetic, the output speed can further improve to 4-5 cycles per digit with recent Intel microarchitectures like Sandy Bridge and Nehalem.

The range-reduction technique demonstrated in Example 14-22 reduces up-to 19 levels of dependency chain down to 5 hierarchy and allows parallel SIMD technique to perform 4-wide numeric conversion. This technique can also be done with only SSSE3, and with similar speed improvement.

Support for conversion to wide character strings can be easily adapted using the code snippet shown in Example 14-23.

Example 14-23. Conversion of 64-bit Integer to Wide Character String Using SSE4

```

static __attribute__((aligned(16))) int ascObias[4] =
{0x30, 0x30, 0x30, 0x30};

// exponent_x must be < 10000 and > 9
__inline int ubs_Lt10k_2wcs_i2(int x_Lt10k, wchar_t *ps)
{
  __m128i x0, m0, x2, x3, x4, compv;
  compv = _mm_loadu_si128( (__m128i *) quo4digComp_mulplr_d);
  x0 = _mm_shuffle_epi32( _mm_cvtsi32_si128( x_Lt10k), 0); // low to high dw: u16, u16, u16, u16
  m0 = _mm_loadu_si128( (__m128i *) quoTenThsn_mulplr_d);
  // u16, 0, u16, 0, u16, 0, u16, 0
  x2 = _mm_mulhi_epu16(x0, m0);
  x2 = _mm_srli_epi32( _mm_madd_epi16( x2, compv), 10); // u16/10, u16/100, u16/1000, u16/10000

  x3 = _mm_insert_epi16(_mm_slli_si128(x2, 6), (int) x_Lt10k, 1); // 0, u16, 0, u16/10, 0, u16/100, 0, u16/1000
  x4 = _mm_or_si128(x2, x3);
  x4 = _mm_madd_epi16(x4, _mm_loadu_si128( (__m128i *) mten_mulplr_d) );
  (continue)
}

```

Example 14-23. Conversion of 64-bit Integer to Wide Character String Using SSE4 (Contd.)

```

x2 = _mm_add_epi32( x4, _mm_loadu_si128( (__m128i *) ascObias) );
x2 = _mm_shuffle_epi32(x2, 0x1b); // switch sequence
if (x_Lt10k > 999) {
    _mm_storeu_si128( (__m128i *) ps, x2);
    return 4;
}
else if (x_Lt10k > 99) {
    *ps++ = (wchar_t) _mm_cvtsi128_si32( _mm_srli_si128( x2, 4));
    *(long long *) ps = _mm_cvtsi128_si64( _mm_srli_si128( x2, 8));
    return 3;
}
else if (x_Lt10k > 9){ // take advantage of reduced dynamic range > 9 to reduce branching
    *(long long *) ps = _mm_cvtsi128_si64( _mm_srli_si128( x2, 8));
    return 2;
}
*ps = L'0' + x_Lt10k;
return 1;
}

long long sse4i_q2wcs_u63 ( __int64_t xx, wchar_t *ps)
{int j, tmp, idx=0, cnt;
 __int64_t lo8, hi8, abv16, temp;
 __m128i x0, m0, x1, x2, x3, x4, x5, x6, x7, m1;

if ( xx < 10000 ) {
    j = abs_Lt10k_2wcs_i2 ( (unsigned ) xx, ps); ps[j] = 0; return j;
}
if (xx < 100000000) { // dynamic range of xx is less than 32-bits
    m0 = _mm_cvtsi32_si128( xx);
    x1 = _mm_shuffle_epi32(m0, 0x44); // broadcast to dw0 and dw2
    x3 = _mm_mul_epu32(x1, _mm_loadu_si128( (__m128i *) pr_cg_10to4 ));
    x3 = _mm_mullo_epi32(_mm_srli_epi64(x3, 40), _mm_loadu_si128( (__m128i *)pr_1_m10to4));
    m0 = _mm_add_epi32( _mm_srli_si128( x1, 8), x3); // quotient in dw2, remainder in dw0
    __ParMod10to4SSSE3v( x3, m0);
    //x4 = _mm_shuffle_epi8(x3, _mm_loadu_si128( (__m128i *) bcstpklodw) );
    x3 = _mm_shuffle_epi32(x3, 0x1b);
    __ParMod10to4SSSE3v( x4, _mm_slli_si128(m0, 8)); // move the remainder to dw2 first
    x4 = _mm_shuffle_epi32(x4, 0x1b);
    cnt = 8;
} else {
    hi8 = u64mod10to8(&lo8, xx);
    if( hi8 < 10000) {
        m0 = _mm_cvtsi32_si128( lo8);
        x2 = _mm_shuffle_epi32(m0, 0x44);
        x3 = _mm_mul_epu32(x2, _mm_loadu_si128( (__m128i *)pr_cg_10to4));
        x3 = _mm_mullo_epi32(_mm_srli_epi64(x3, 40), _mm_loadu_si128( (__m128i *)pr_1_m10to4));

        m0 = _mm_add_epi32( _mm_srli_si128( x2, 8), x3);
        __ParMod10to4SSSE3v( x3, hi8);
        x3 = _mm_shuffle_epi32(x3, 0x1b);
        __ParMod10to4SSSE3v( x4, m0);
        x4 = _mm_shuffle_epi32(x4, 0x1b);
        (continue)
    }
}
}

```

Example 14-23. Conversion of 64-bit Integer to Wide Character String Using SSE4 (Contd.)

```

    __ParMod10to4SSSE3v( x5, __mm_slli_si128(m0, 8));
    x5 = __mm_shuffle_epi32(x5, 0x1b);
    cnt = 12;
} else {
    cnt = 0;
    if ( hi8 > 100000000) {
        abv16 = u64mod10to8(&temp, (__int64_t)hi8);
        hi8 = temp;
        __ParMod10to4SSSE3( x7, abv16);
        x7 = __mm_shuffle_epi32(x7, 0x1b);
        cnt = 4;
    }
    m0 = __mm_cvtsi32_si128( hi8);
    x2 = __mm_shuffle_epi32(m0, 0x44);
    x3 = __mm_mul_epu32(x2, __mm_loadu_si128( (__m128i *)pr_cg_10to4));
    x3 = __mm_mullo_epi32(__mm_srli_epi64(x3, 40), __mm_loadu_si128( (__m128i *)pr_1_m10to4));
    m0 = __mm_add_epi32( __mm_srli_si128( x2, 8), x3);
    m1 = __mm_cvtsi32_si128( lo8);
    x2 = __mm_shuffle_epi32(m1, 0x44);
    x3 = __mm_mul_epu32(x2, __mm_loadu_si128( (__m128i *)pr_cg_10to4));
    x3 = __mm_mullo_epi32(__mm_srli_epi64(x3, 40), __mm_loadu_si128( (__m128i *)pr_1_m10to4));
    m1 = __mm_add_epi32( __mm_srli_si128( x2, 8), x3);
    __ParMod10to4SSSE3v( x3, m0);
    x3 = __mm_shuffle_epi32(x3, 0x1b);
    __ParMod10to4SSSE3v( x4, __mm_slli_si128(m0, 8));
    x4 = __mm_shuffle_epi32(x4, 0x1b);
    __ParMod10to4SSSE3v( x5, m1);
    x5 = __mm_shuffle_epi32(x5, 0x1b);
    __ParMod10to4SSSE3v( x6, __mm_slli_si128(m1, 8));
    x6 = __mm_shuffle_epi32(x6, 0x1b);
    cnt += 16;
}
}

m0 = __mm_loadu_si128( (__m128i *) asc0bias);
if( cnt > 16) {
    tmp = __mm_movemask_epi8( __mm_cmpgt_epi32(x7, __mm_setzero_si128()));
    //x7 = __mm_add_epi32(x7, m0);
} else {
    tmp = __mm_movemask_epi8( __mm_cmpgt_epi32(x3, __mm_setzero_si128()));
}
#ifdef __USE_GCC__
    __asm__ ("bsfl %1, %%ecx; movl %%ecx, %0; : "=r"(idx) : "r"(tmp) : "%ecx");
#else
    _BitScanForward(&idx, tmp);
#endif
#endif
x3 = __mm_add_epi32(x3, m0);
cnt -= (idx >> 2);
x4 = __mm_add_epi32(x4, m0);
switch(cnt) {
case5:*ps++ = (wchar_t) __mm_cvtsi128_si32( __mm_srli_si128( x3, 12));
    __mm_storeu_si128( (__m128i *) ps, x4);
break;
case6:*(long long *)ps = __mm_cvtsi128_si64( __mm_srli_si128( x3, 8));
    __mm_storeu_si128( (__m128i *) &ps[2], x4);
break;
        (continue)

```

Example 14-23. Conversion of 64-bit Integer to Wide Character String Using SSE4 (Contd.)

```

case7:*ps++ = (wchar_t)_mm_cvtsi128_si32(_mm_srli_si128(x3, 4));
*(long long *)ps = _mm_cvtsi128_si64(_mm_srli_si128(x3, 8));
_mm_storeu_si128((__m128i *)&ps[2], x4);
break;
case 8: _mm_storeu_si128((__m128i *)&ps[0], x3);
_mm_storeu_si128((__m128i *)&ps[4], x4);
break;
case9:*ps++ = (wchar_t)_mm_cvtsi128_si32(_mm_srli_si128(x3, 12));
x5 = _mm_add_epi32(x5, m0);
_mm_storeu_si128((__m128i *)ps, x4);
_mm_storeu_si128((__m128i *)&ps[4], x5);
break;
case10:*(long long *)ps = _mm_cvtsi128_si64(_mm_srli_si128(x3, 8));
x5 = _mm_add_epi32(x5, m0);
_mm_storeu_si128((__m128i *)&ps[2], x4);
_mm_storeu_si128((__m128i *)&ps[6], x5);
break;

case11:*ps++ = (wchar_t)_mm_cvtsi128_si32(_mm_srli_si128(x3, 4));
*(long long *)ps = _mm_cvtsi128_si64(_mm_srli_si128(x3, 8));
x5 = _mm_add_epi32(x5, m0);
_mm_storeu_si128((__m128i *)&ps[2], x4);
_mm_storeu_si128((__m128i *)&ps[6], x5);
break;
case 12: _mm_storeu_si128((__m128i *)&ps[0], x3);
x5 = _mm_add_epi32(x5, m0);
_mm_storeu_si128((__m128i *)&ps[4], x4);
_mm_storeu_si128((__m128i *)&ps[8], x5);
break;
case13:*ps++ = (wchar_t)_mm_cvtsi128_si32(_mm_srli_si128(x3, 12));
x5 = _mm_add_epi32(x5, m0);
_mm_storeu_si128((__m128i *)ps, x4);
x6 = _mm_add_epi32(x6, m0);
_mm_storeu_si128((__m128i *)&ps[4], x5);
_mm_storeu_si128((__m128i *)&ps[8], x6);
break;
case14:*(long long *)ps = _mm_cvtsi128_si64(_mm_srli_si128(x3, 8));
x5 = _mm_add_epi32(x5, m0);
_mm_storeu_si128((__m128i *)&ps[2], x4);
x6 = _mm_add_epi32(x6, m0);
_mm_storeu_si128((__m128i *)&ps[6], x5);
_mm_storeu_si128((__m128i *)&ps[10], x6);
break;
case15:*ps++ = (wchar_t)_mm_cvtsi128_si32(_mm_srli_si128(x3, 4));
*(long long *)ps = _mm_cvtsi128_si64(_mm_srli_si128(x3, 8));
x5 = _mm_add_epi32(x5, m0);
_mm_storeu_si128((__m128i *)&ps[2], x4);
x6 = _mm_add_epi32(x6, m0);
_mm_storeu_si128((__m128i *)&ps[6], x5);
_mm_storeu_si128((__m128i *)&ps[10], x6);
break;
(continue)

```

Example 14-23. Conversion of 64-bit Integer to Wide Character String Using SSE4 (Contd.)

```

case 16: _mm_storeu_si128( (__m128i *) &ps[0], x3);
        x5 = _mm_add_epi32(x5, m0);
        _mm_storeu_si128( (__m128i *) &ps[4], x4);
        x6 = _mm_add_epi32(x6, m0);
        _mm_storeu_si128( (__m128i *) &ps[8], x5);
        _mm_storeu_si128( (__m128i *) &ps[12], x6);
        break;

case 17: x7 = _mm_add_epi32(x7, m0);
        *ps++ = (wchar_t) _mm_cvtsi128_si32( _mm_srli_si128( x7, 12));
        x5 = _mm_add_epi32(x5, m0);
        _mm_storeu_si128( (__m128i *) ps, x3);
        x6 = _mm_add_epi32(x6, m0);
        _mm_storeu_si128( (__m128i *) &ps[4], x4);
        _mm_storeu_si128( (__m128i *) &ps[8], x5);
        _mm_storeu_si128( (__m128i *) &ps[12], x6);
        break;

case 18: x7 = _mm_add_epi32(x7, m0);
        *(long long *)ps = _mm_cvtsi128_si64( _mm_srli_si128( x7, 8));
        x5 = _mm_add_epi32(x5, m0);
        _mm_storeu_si128( (__m128i *) &ps[2], x3);
        x6 = _mm_add_epi32(x6, m0);
        _mm_storeu_si128( (__m128i *) &ps[6], x4);
        _mm_storeu_si128( (__m128i *) &ps[10], x5);
        _mm_storeu_si128( (__m128i *) &ps[14], x6);
        break;

case 19: x7 = _mm_add_epi32(x7, m0);
        *ps++ = (wchar_t) _mm_cvtsi128_si64( _mm_srli_si128( x7, 4));
        *(long long *)ps = _mm_cvtsi128_si64( _mm_srli_si128( x7, 8));
        x5 = _mm_add_epi32(x5, m0);
        _mm_storeu_si128( (__m128i *) &ps[2], x3);
        x6 = _mm_add_epi32(x6, m0);
        _mm_storeu_si128( (__m128i *) &ps[6], x4);
        _mm_storeu_si128( (__m128i *) &ps[10], x5);
        _mm_storeu_si128( (__m128i *) &ps[14], x6);
        break;

case 20: x7 = _mm_add_epi32(x7, m0);
        _mm_storeu_si128( (__m128i *) &ps[0], x7);
        x5 = _mm_add_epi32(x5, m0);
        _mm_storeu_si128( (__m128i *) &ps[4], x3);
        x6 = _mm_add_epi32(x6, m0);
        _mm_storeu_si128( (__m128i *) &ps[8], x4);
        _mm_storeu_si128( (__m128i *) &ps[12], x5);
        _mm_storeu_si128( (__m128i *) &ps[16], x6);
        break;
    }
    return cnt;
}

```

14.5.1 Large Integer Numeric Computation

14.5.1.1 MULX Instruction and Large Integer Numeric Computation

The MULX instruction is similar to the MUL instruction but does not read or write arithmetic flags and is enhanced with more flexibility in register allocations for the destination operands. These enhancements allow better out-of-order operation of the hardware and for software to intermix add-carry instruction without corrupting the carry chain.

For computations calculating large integers (e.g. 2048-bit RSA key), MULX can improve performance significantly over techniques based on MUL/ADC chain sequences (see <http://www.intel.com/content/dam/www/public/us/en/documents/white-papers/ia-large-integer-arithmetic-paper.pdf>). AVX2 can be used to build efficient techniques, see Section 15.16.2.

Example 14-24 gives an example of how MULX is used to improve the carry chain computation of integer numeric greater than 64-bit wide.

Example 14-24. MULX and Carry Chain in Large Integer Numeric

<pre> mov rax, [rsi+8*1] mul rbp ; rdx:rax = rax * rbp mov r8, rdx add r9, rax adc r8, 0 add r9, rbx adc r8, 0 </pre>	<pre> mulx rbx, r8, [rsi+8*1] ; rbx:r8 = rdx * [rsi+8*1] add r8, r9 adc rbx, 0 add r8, rbx adc rbx, 0 </pre>
--	--

Using MULX to implement 128-bit integer output can be a useful building block for implementing library functions ranging from `atof/strtod` or intermediate mantissa computation or mantissa/exponent normalization in 128-bit binary decimal floating-point operations. Example 14-25 gives examples of building-block macros, used in 128-bit binary-decimal floating-point operations, which can take advantage MULX to calculate intermediate results of multiple-precision integers of widths between 128 to 256 bits. Details of binary-integer-decimal (BID) floating-point format and library implementation of BID operation can be found at <http://software.intel.com/en-us/articles/intel-decimal-floating-point-math-library>.

Example 14-25. Building-block Macro Used in Binary Decimal Floating-point Operations

```

// Portable C macro of 64x64-bit product using 32-bit word granular operations
// Output: BID_UINT128 P128
#define __mul_64x64_to_128MACH(P128, CX64, CY64) \
{
    BID_UINT64 CXH,CXL,CYH,CYL,PL,PH,PM,PM2; \
    CXH = (CX64) >> 32; \
    CXL = (BID_UINT32)(CX64); \
    CYH = (CY64) >> 32; \
    CYL = (BID_UINT32)(CY64); \
    PM = CXH*CYL; \
    PH = CXH*CYH; \
    PL = CXL*CYL; \
    PM2 = CXL*CYH; \
    PH += (PM>>32); \
    PM = (BID_UINT64)((BID_UINT32)PM)+PM2+(PL>>32); \
    (P128).w[1] = PH + (PM>>32); \
    (P128).w[0] = (PM<<32)+(BID_UINT32)PL; \
}

// 64x64-bit product using intrinsic producing 128-bit output in 64-bit mode
// Output: BID_UINT128 P128
#define __mul_64x64_to_128MACH_x64(P128, CX64, CY64) \
{
    (P128).w[0] = mulx_u64(CX64, CY64, &( (P128).w[1] )); \
}

```

CHAPTER 15 OPTIMIZATIONS FOR INTEL® AVX, FMA AND AVX2

Intel® Advanced Vector Extension (Intel® AVX), is a major enhancement to Intel Architecture. It extends the functionality of previous generations of 128-bit SSE vector instructions and increased the vector register width to support 256-bit operations. The Intel AVX ISA enhancement is focused on float-point instructions. Some 256-bit integer vectors are supported via floating-point to integer and integer to floating-point conversions.

Sandy Bridge microarchitecture implements the Intel AVX instructions, in most cases, on 256-bit hardware. Thus, each core has 256-bit floating-point Add and Multiply units. The Divide and Square-root units are not enhanced to 256-bits. Thus, Intel AVX instructions use the 128-bit hardware in two steps to complete these 256-bit operations.

Prior generations of Intel® Streaming SIMD Extensions (Intel® SSE) instructions generally are two-operand syntax, where one of the operands serves both as source and as destination. Intel AVX instructions are encoded with a VEX prefix, which includes a bit field to encode vector lengths and support three-operand syntax. A typical instruction has two sources and one destination. Four operand instructions such as VBLENDVPS and VBLENDVPD exist as well. The added operand enables non-destructive source (NDS) and it eliminates the need for register duplication using MOVAPS operations.

With the exception of MMX instructions, almost all legacy 128-bit SSE instructions have AVX equivalents that support three operand syntax. 256-bit AVX instructions employ three-operand syntax and some with 4-operand syntax.

The 256-bit vector register, YMM, extends the 128-bit XMM register to 256 bits. Thus the lower 128-bits of YMM is aliased to the legacy XMM registers.

While 256-bit AVX instructions writes 256 bits of results to YMM, 128-bit AVX instructions writes 128-bits of results into the XMM register and zeros the upper bits above bit 128 of the corresponding YMM. 16 vector registers are available in 64-bit mode. Only the lower 8 vector registers are available in non-64-bit modes.

Software can continue to use any mixture of legacy SSE code, 128-bit AVX code and 256-bit AVX code. Section covers guidelines to deliver optimal performance across mixed-vector-length code modules without experiencing transition delays between legacy SSE and AVX code. There are no transition delays of mixing 128-bit AVX code and 256-bit AVX code.

The optimal memory alignment of an Intel AVX 256-bit vector, stored in memory, is 32 bytes. Some data-movement 256-bit Intel AVX instructions enforce 32-byte alignment and will signal #GP fault if memory operand is not properly aligned. The majority of 256-bit Intel AVX instructions do not require address alignment. These instructions generally combine load and compute operations, so any non-aligned memory address can be used in these instructions.

For best performance, software should pay attention to align the load and store addresses to 32 bytes whenever possible.

The major differences between using AVX instructions and legacy SSE instructions are summarized in Table 15-1 below.

Table 15-1. Features between 256-bit AVX, 128-bit AVX and Legacy SSE Extensions

Features	256-bit AVX	128-bit AVX	Legacy SSE-AESNI
Functionality Scope	Floating-point operation, Data Movement.	Matches legacy SIMD ISA (except MMX).	128-bit FP and integer SIMD ISA.
Register Operand	YMM.	XMM.	XMM.
Operand Syntax	Up to 4; non-destructive source.	Up to 4; non-destructive source.	2 operand syntax; destructive source.
Memory alignment	Load-Op semantics do not require alignment.	Load-Op semantics do not require alignment.	Always enforce 16B alignment.
Aligned Move Instructions	32 byte alignment.	16 byte alignment.	16 byte alignment.
Non-destructive source operand	Yes.	Yes.	No.
Register State Handling	Updates bits 255:0.	Updates 127:0; Zeroes bits above 128.	Updates 127:0; Bits above 128 unmodified.
Intrinsic Support	<ul style="list-style-type: none"> ▪ New 256-bit data types. ▪ <code>_mm256</code> prefix for promoted functionality. ▪ New intrinsics for new functionalities. 	<ul style="list-style-type: none"> ▪ Existing data types. ▪ Inherit same prototype for exiting functionalities. ▪ Use “<code>_mm</code>” prefix for new VEX-128 functionalities. 	Baseline datatypes and prototype definitions.
128-bit Lanes	Applies to most 256-bit operations.	One 128-bit lane.	One 128-bit lane.
Mixed Code Handling	Use <code>VZERoupper</code> to avoid transition penalty.	No transition penalty.	Transition penalty after executing 256-bit AVX code.

15.1 INTEL® AVX INTRINSICS CODING

256-bit AVX instructions have new intrinsics. Specifically, 256-bit AVX instruction that are promoted to 256-bit vector length from existing SSE functionality are generally prototyped with a “`_mm256`” prefix instead of the “`_mm`” prefix and using new data types defined for 256-bit operation. New functionality in 256-bit AVX instructions have brand new prototype.

The 128-bit AVX instruction that were promoted from legacy SIMD ISA uses the same prototype as before. Newer functionality common in 256-bit and 128-bit AVX instructions are prototyped with “`_mm256`” and “`_mm`” prefixes respectively.

Thus porting from legacy SIMD code written in intrinsic can be ported to 256-bit AVX code with a modest effort.

The following guidelines show how to convert a simple intrinsic from Intel SSE code sequence to Intel AVX:

- Align statically and dynamically allocated buffers to 32-bytes.
- May need to double supplemental buffer size.
- Change `__mm_` intrinsic name prefix with `__mm256_`.
- Change variable data types names from `__m128` to `__m256`.
- Divide by 2 iteration count (or double stride length).

This example below on Cartesian coordinate transformation demonstrates the Intel AVX Instruction format, 32 byte YMM registers, dynamic and static memory allocation with data alignment of 32bytes, and the C data type representing 8 floating-point elements in a YMM register.

Example 15-1. Cartesian Coordinate Transformation with Intrinsics

<pre> //Use SSE intrinsic #include "wmmintrin.h" int main() { int len = 3200; //Dynamic memory allocation with 16byte //alignment float* plnVector = (float*) _mm_malloc(len*sizeof(float), 16); float* pOutVector = (float*) _mm_malloc(len*sizeof(float), 16); //init data for(int i=0; i<len; i++) plnVector[i] = 1; float cos_teta = 0.8660254037; float sin_teta = 0.5; //Static memory allocation of 4 floats with 16byte alignment __declspec(align(16)) float cos_sin_teta_vec[4] = {cos_teta, sin_teta, cos_teta, sin_teta}; __declspec(align(16)) float sin_cos_teta_vec[4] = {sin_teta, cos_teta, sin_teta, cos_teta}; //__m128 data type represents an xmm //register with 4 float elements __m128 Xmm_cos_sin = _mm_load_ps(cos_sin_teta_vec); //SSE 128bit packed single load __m128 Xmm_sin_cos = _mm_load_ps(sin_cos_teta_vec); __m128 Xmm0, Xmm1, Xmm2, Xmm3; //processing 8 elements in an unrolled twice loop for(int i=0; i<len; i+=8) { Xmm0 = _mm_load_ps(plnVector+i); Xmm1 = _mm_moveldup_ps(Xmm0); Xmm2 = _mm_movehdup_ps(Xmm0); Xmm1 = _mm_mul_ps(Xmm1,Xmm_cos_sin); Xmm2 = _mm_mul_ps(Xmm2,Xmm_sin_cos); Xmm3 = _mm_addsub_ps(Xmm1, Xmm2); _mm_store_ps(pOutVector + i, Xmm3); } </pre>	<pre> // Use Intel AVX intrinsic #include "immintrin.h" int main() { int len = 3200; //Dynamic memory allocation with 32byte //alignment float* plnVector = (float*) _mm_malloc(len*sizeof(float), 32); float* pOutVector = (float*) _mm_malloc(len*sizeof(float), 32); //init data for(int i=0; i<len; i++) plnVector[i] = 1; float cos_teta = 0.8660254037; float sin_teta = 0.5; //Static memory allocation of 8 floats with 32byte alignment __declspec(align(32)) float cos_sin_teta_vec[8] = {cos_teta, sin_teta, cos_teta, sin_teta, cos_teta, sin_teta, cos_teta, sin_teta}; __declspec(align(32)) float sin_cos_teta_vec[8] = {sin_teta, cos_teta, sin_teta, cos_teta, sin_teta, cos_teta, sin_teta, cos_teta }; //__m256 data type holds 8 float elements __m256 Ymm_cos_sin = _mm256_load_ps(cos_sin_teta_vec); //AVX 256bit packed single load __m256 Ymm_sin_cos = _mm256_load_ps(sin_cos_teta_vec); __m256 Ymm0, Ymm1, Ymm2, Ymm3; //processing 8 elements in an unrolled twice loop for(int i=0; i<len; i+=16) { Ymm0 = _mm256_load_ps(plnVector+i); Ymm1 = _mm256_moveldup_ps(Ymm0); Ymm2 = _mm256_movehdup_ps(Ymm0); Ymm1 = _mm256_mul_ps(Ymm1,Ymm_cos_sin); Ymm2 = _mm256_mul_ps(Ymm2,Ymm_sin_cos); Ymm3 = _mm256_addsub_ps(Ymm1, Ymm2); _mm256_store_ps(pOutVector + i, Ymm3); } </pre>
---	--

Example 15-1. Cartesian Coordinate Transformation with Intrinsics (Contd.)

<pre> Xmm0 = _mm_load_ps(plnVector+i+4); Xmm1 = _mm_moveldup_ps(Xmm0); Xmm2 = _mm_movehdup_ps(Xmm0); Xmm1 = _mm_mul_ps(Xmm1,Xmm_cos_sin); Xmm2 = _mm_mul_ps(Xmm2,Xmm_sin_cos); Xmm3 = _mm_addsub_ps(Xmm1, Xmm2); _mm_store_ps(pOutVector+i+4, Xmm3); } _mm_free(plnVector); _mm_free(pOutVector); return 0; } </pre>	<pre> Ymm0 = _mm256_load_ps(plnVector+i+8); Ymm1 = _mm256_moveldup_ps(Ymm0); Ymm2 = _mm256_movehdup_ps(Ymm0); Ymm1 = _mm256_mul_ps(Ymm1,Ymm_cos_sin); Ymm2 = _mm256_mul_ps(Ymm2,Ymm_sin_cos); Ymm3 = _mm256_addsub_ps(Ymm1, Ymm2); _mm256_store_ps(pOutVector+i+8, Ymm3); } _mm_free(plnVector); _mm_free(pOutVector); return 0; } </pre>
--	---

15.1.1 Intel® AVX Assembly Coding

Similar to the intrinsic porting guidelines, assembly porting guidelines are listed below.

- Align statically and dynamically allocated buffers to 32-bytes.
- Double the supplemental buffer sizes if needed.
- Add a “v” prefix to instruction names.
- Change register names from xmm to ymm.
- Add destination registers to computational Intel AVX instructions.
- Divide the iteration count by two (or double stride length).

Example 15-2. Cartesian Coordinate Transformation with Assembly

<pre> //Use SSE Assembly int main() { int len = 3200; //Dynamic memory allocation with 16byte //alignment float* plnVector = (float*) _mm_malloc(len*sizeof(float), 16); float* pOutVector = (float*) _mm_malloc(len*sizeof(float), 16); //init data for(int i=0; i<len; i++) plnVector[i] = 1; //Static memory allocation of 4 floats //with 16byte alignment float cos_teta = 0.8660254037; float sin_teta = 0.5; __declspec(align(16)) float cos_sin_teta_vec[4] = {cos_teta, sin_teta, cos_teta, sin_teta}; </pre>	<pre> // Use Intel AVX assembly int main() { int len = 3200; //Dynamic memory allocation with 32byte //alignment float* plnVector = (float*) _mm_malloc(len*sizeof(float), 32); float* pOutVector = (float*) _mm_malloc(len*sizeof(float), 32); //init data for(int i=0; i<len; i++) plnVector[i] = 1; //Static memory allocation of 8 floats //with 32byte alignment float cos_teta = 0.8660254037; float sin_teta = 0.5; __declspec(align(32)) float cos_sin_teta_vec[8] = {cos_teta, sin_teta, cos_teta, sin_teta, cos_teta, sin_teta, cos_teta, sin_teta}; </pre>
---	--

Example 15-2. Cartesian Coordinate Transformation with Assembly (Contd.)

<pre> __declspec(align(16)) float sin_cos_teta_vec[4] = {sin_teta, cos_teta, sin_teta, cos_teta}; //processing 8 elements in an unrolled-twice loop __asm { mov rax, plnVector mov rbx, pOutVector // Load into an xmm register of 16 bytes movups xmm3, xmmword ptr[cos_sin_teta_vec] movups xmm4, xmmword ptr[sin_cos_teta_vec] mov rdx, len shl rdx, 2 //size of input array in bytes xor rcx, rcx loop1: movsldup xmm0, [rax+rcx] movshdup xmm1, [rax+rcx] //example: mulps has 2 operands mulps xmm0, xmm3 mulps xmm1, xmm4 addsubps xmm0, xmm1 // 16 byte store from an xmm register movaps [rbx+rcx], xmm0 movsldup xmm0, [rax+rcx+16] movshdup xmm1, [rax+rcx+16] mulps xmm0, xmm3 mulps xmm1, xmm4 addsubps xmm0, xmm1 // offset of 16 bytes from previous store movaps [rbx+rcx+16], xmm0 // Processed 32bytes in this loop //(The code is unrolled twice) add rcx, 32 cmp rcx, rdx jl loop1 } _mm_free(plnVector); _mm_free(pOutVector); return 0; } </pre>	<pre> __declspec(align(32)) float sin_cos_teta_vec[8] = {sin_teta, cos_teta, sin_teta, cos_teta, sin_teta, cos_teta, sin_teta, cos_teta}; //processing 16 elements in an unrolled-twice loop __asm { mov rax, plnVector mov rbx, pOutVector // Load into an ymm register of 32 bytes vmovups ymm3, ymmword ptr[cos_sin_teta_vec] vmovups ymm4, ymmword ptr[sin_cos_teta_vec] mov rdx, len shl rdx, 2 //size of input array in bytes xor rcx, rcx loop1: vmovsldup ymm0, [rax+rcx] vmovshdup ymm1, [rax+rcx] //example: vmulps has 3 operands vmulps ymm0, ymm0, ymm3 vmulps ymm1, ymm1, ymm4 vaddsubps ymm0, ymm0, ymm1 // 32 byte store from an ymm register vmovaps [rbx+rcx], ymm0 vmovsldup ymm0, [rax+rcx+32] vmovshdup ymm1, [rax+rcx+32] vmulps ymm0, ymm0, ymm3 vmulps ymm1, ymm1, ymm4 vaddsubps ymm0, ymm0, ymm1 // offset of 32 bytes from previous store vmovaps [rbx+rcx+32], ymm0 // Processed 64bytes in this loop //(The code is unrolled twice) add rcx, 64 cmp rcx, rdx jl loop1 } _mm_free(plnVector); _mm_free(pOutVector); return 0; } </pre>
---	---

15.2 NON-DESTRUCTIVE SOURCE (NDS)

Most Intel AVX instructions have three operands. A typical instruction has two sources and one destination, with both source operands unmodified by the instruction. This section describes how using the NDS feature to save register copies, reduce the amount of instructions, reduce the amount of micro-ops, and improve performance. In this example, the Intel AVX code is more than 2x faster than the Intel SSE code.

The following example uses a vectorized calculation of the polynomial A^3+A^2+A . The polynomial calculation pseudo code is:

```
While (i<len)
{
  B[i] := A[i]^3 + A[i]^2 + A[i]
  i++
}
```

In Example 15-3 below, the left column shows the vectorized implementation using SSE assembly. In this code, A is copied by an additional load from memory to a register, and A2 is copied using a register to register assignment. The code uses 10 micro-ops to process four elements.

The middle column in this example uses 128-bit Intel AVX instructions and takes advantage of NDS. The additional load and register copies are eliminated. This code uses 8 micro-ops to process four elements and is about 30% faster than the baseline above.

The right column in this example uses 256-bit Intel AVX instructions. It uses 8 micro-ops to process 8 elements. Combining the NDS feature with the doubling of vector width, this speeds up the baseline by more than 2x.

Example 15-3. Direct Polynomial Calculation

SSE Code	128-bit AVX Code	256-bit AVX Code
<pre>float* pA = InputBuffer; float* pB = OutputBuffer; int len = miBufferWidth-4; __asm { mov rax, pA mov rbx, pB movsxd r8, len loop1: //Load A movups xmm0, [rax+r8*4] //Copy A movups xmm1, [rax+r8*4] //A^2 mulps xmm1, xmm1 //Copy A^2 movupsxmm2, xmm1 //A^3 mulps xmm2, xmm0 //A + A^2 addps xmm0, xmm1 //A + A^2 + A^3 addps xmm0, xmm2 //Store result movups[rbx+r8*4], xmm0</pre>	<pre>float* pA = InputBuffer1; float* pB = OutputBuffer1; int len = miBufferWidth-4; __asm { mov rax, pA mov rbx, pB movsxd r8, len loop1: //Load A vmovups xmm0, [rax+r8*4] //A^2 vmulps xmm1, xmm0, xmm0 //A^3 vmulps xmm2, xmm1, xmm0 //A+A^2 vaddps xmm0, xmm0, xmm1 //A+A^2+A^3 vaddps xmm0, xmm0, xmm2 //Store result vmovups[rbx+r8*4], xmm0</pre>	<pre>float* pA = InputBuffer1; float* pB = OutputBuffer1; int len = miBufferWidth-8; __asm { mov rax, pA mov rbx, pB movsxd r8, len loop1: //Load A vmovups ymm0, [rax+r8*4] //A^2 vmulps ymm1, ymm0, ymm0 //A^3 vmulps ymm2, ymm1, ymm0 //A+A^2 vaddps ymm0, ymm0, ymm1 //A+A^2+A^3 vaddps ymm0, ymm0, ymm2 //Store result vmovups [rbx+r8*4], ymm0</pre>

Example 15-3. Direct Polynomial Calculation (Contd.)

SSE Code	128-bit AVX Code	256-bit AVX Code
sub r8, 4 jge loop1 }	sub r8, 4 jge loop1 }	sub r8, 8 jge loop1 }

15.3 MIXING AVX CODE WITH SSE CODE

The Intel AVX architecture allows programmers to port a large code base gradually, resulting in mixed AVX code and SSE code. If your code includes both Intel AVX and Intel SSE, consider the following:

- Recompilation of Intel SSE code with the Intel compiler and the option `/QxAVX` in Windows or `-xAVX` in Linux. This transforms all SSE instructions to 128-bit Intel AVX instructions automatically. This refers to inline assembly and intrinsic code. `“GCC -c -mAVX”` will generate AVX code, including assembly files. GCC assembler also supports `“-msse2avx”` switch to generate AVX code from SSE.
- Intel AVX and Intel SSE code can co-exist and execute in the same run. This can happen if your application includes third party libraries with Intel SSE code, a new DLL using AVX code is deployed that calls other modules running SSE code, or you cannot recompile all your application at once. In these cases, the AVX code must use the `VZERoupper` instruction to avoid AVX/SSE transition penalty.

Intel AVX instructions always modify the upper bits of YMM registers and SSE instructions do not modify the upper bits. From a hardware perspective, the upper bits of the YMM register collection can be considered to be in one of three states:

- Clean: All upper bits of YMM are zero. This is the state when the processor starts from RESET.
- Modified and Unsaved (In Table 15-2, this is abbreviated as M/U): The execution of one AVX instruction (either 256-bit or 128-bit) modifies the upper bits of the destination YMM. This is also referred to as dirty upper YMM state. In this state, bits 255:128 and bits 127:0 of a given YMM are related to the most recent 256-bit or 128-bit AVX instruction that operated on that register.
- Preserved/Non_INIT Upper State (In Table 15-2, this is abbreviated as P/N): In this state, the upper YMM state is not zero. The upper 128 bits of a YMM and the lower 128 bits may be unrelated to the last AVX instruction executed in the processor as a result of `XRSTOR` from a saved image with dirty upper YMM state.

If software inter-mixes AVX and SSE instructions without using `VZERoupper` properly, it can experience an AVX/SSE transition penalty. The situations of executing SSE, AVX, or managing the YMM state using `XSAVE/XRSTOR/VZERoupper/VZEROALL` is illustrated in Figure 15-1. The penalty associated with transitions into or out of the processor state “Modified and Unsaved” is implementation specific, depending on the microarchitecture.

Figure 15-1 depicts the situations that a transition penalty will occur for recent generations of microarchitectures that support AVX, up to and including the Broadwell microarchitecture. The transition penalty of A and B occurs with each instruction execution that would cause the transition. It is largely the cost of copying the entire YMM state to internal storage.

To minimize the occurrence of YMM state transitions related to the “Preserved/Non_INIT Upper State”, software that uses `XSAVE/XRSTOR` family of instructions to save/restore the YMM state should write a “Clean” upper YMM state to the `XSAVE` region in memory. Restoring a dirty YMM image from memory into the YMM registers can experience a penalty. This is illustrated in Figure 15-1.

The Skylake microarchitecture implements a different state machine than prior generations to manage the YMM state transition associated with mixing SSE and AVX instructions. It no longer saves the entire upper YMM state when executing an SSE instruction when in “Modified and Unsaved” state, but saves the upper bits of individual register. As a result, mixing SSE and AVX instructions will experience a penalty associated with partial register dependency of the destination registers being used and additional blend operation on the upper bits of the destination registers. Figure 15-2 depicts the transition penalty applicable to the Skylake microarchitecture.

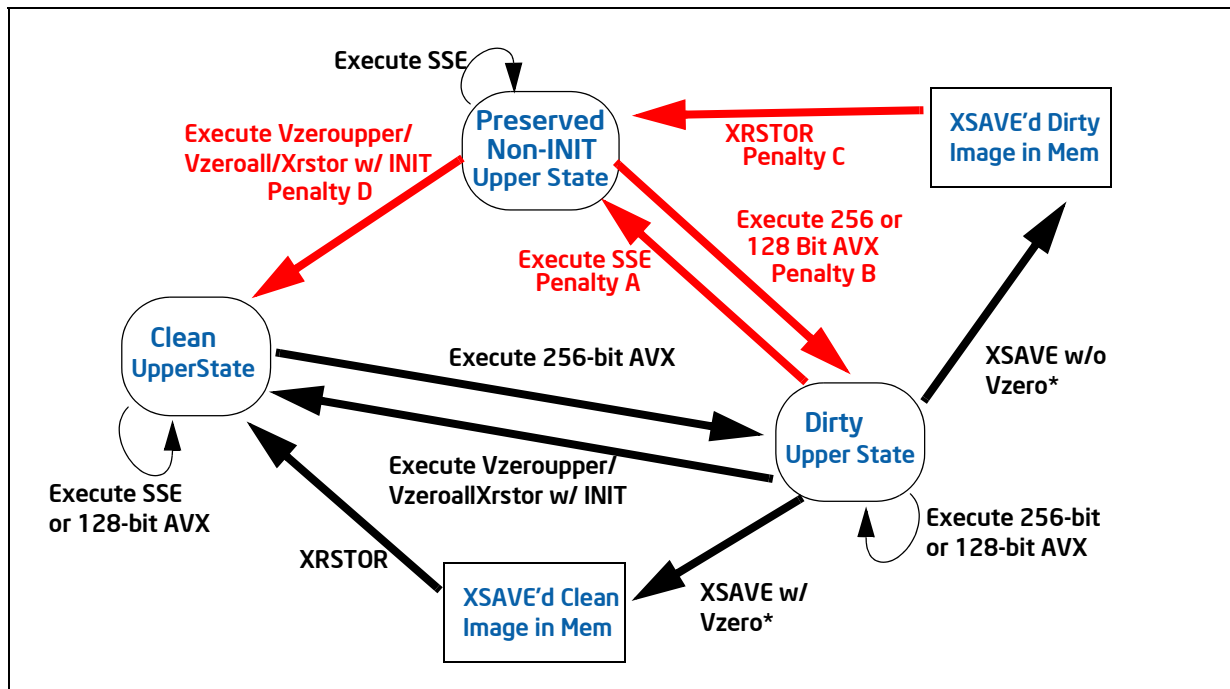

Figure 15-1. AVX-SSE Transitions in the Broadwell, and Prior Generation Microarchitectures

Table 15-2 lists the effect of mixing Intel AVX and Intel SSE code, with the bottom row indicating the types of penalty that might arise depending on the initial YMM state (the row marked 'Begin') and the ending state. Table 15-2 also includes the effect of transition penalty (Type C and D) associated with restoring a dirty YMM state image stored in memory.

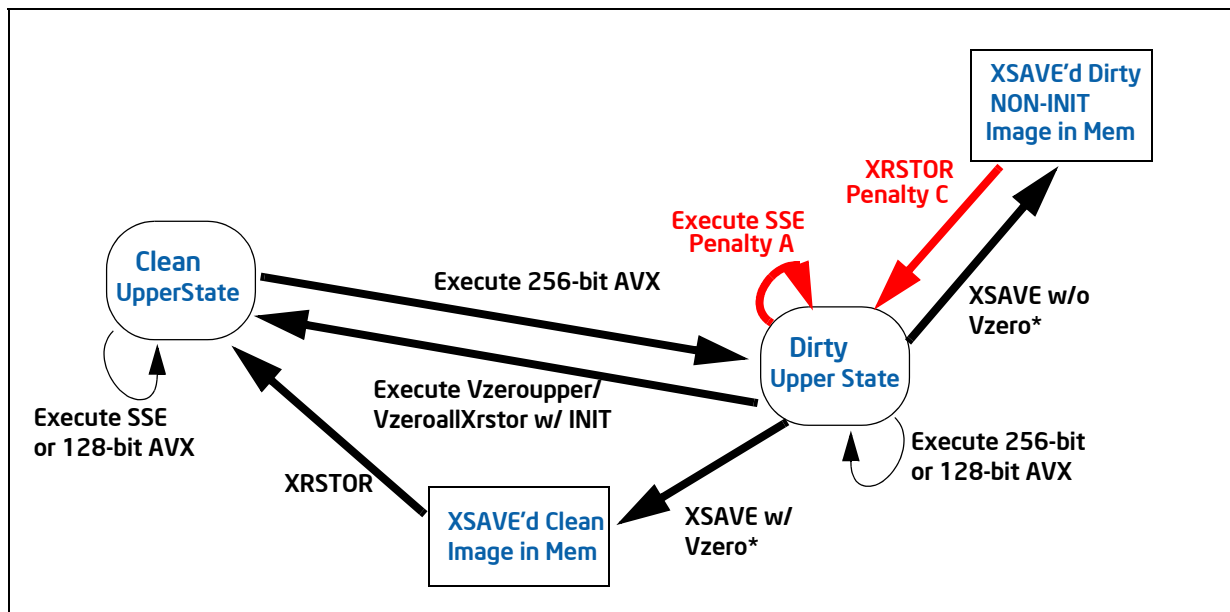

Figure 15-2. AVX-SSE Transitions in the Skylake Microarchitecture

Table 15-2. State Transitions of Mixing AVX and SSE Code

	Execute SSE			Execute AVX-128			Execute AVX-256			VZeroupper	XRSTOR	
Begin	Clean	M/U	P/N	Clean	M/U	P/S	Clean	M/U	P/N	P/N	Dirty Image	Clean Image
End	Clean	P/N	P/N	Clean	M/U	M/U	M/U	M/U	M/U	Clean	P/N	Clean
Penalty	No	A	No	No	No	B	No	No	B	D	C	No

The magnitude of each type of transition penalty can vary across different microarchitectures. In Skylake microarchitecture, some of the transition penalty is reduced. The transition diagram and associated penalty is depicted in Figure 15-2. Table 15-3 gives approximate order of magnitude of the different transition penalty types across recent microarchitectures.

Table 15-3. Approximate Magnitude of AVX-SSE Transition Penalties in Different Microarchitectures

Type	Haswell Microarchitecture	Broadwell Microarchitecture	Skylake Microarchitecture	Ice Lake Client Microarchitecture
A	~XSAVE	~XSAVE	Partial Register Dependency + Blend	~XSAVE
B	~XSAVE	~XSAVE	NA	~XSAVE
C	~Fraction of XSAVE	~Fraction of XSAVE	~XSAVE	~Fraction of XSAVE
D	~XSAVE	~XSAVE	NA	~XSAVE

To enable fast transitions between 256-bit Intel AVX and Intel SSE code blocks, use the VZERoupper instruction before and after an AVX code block that would need to switch to execute SSE code. The VZERoupper instruction resets the upper 128 bits of all Intel AVX registers. This instruction has zero latency. In addition, the processor changes back to a Clean state, after which execution of SSE instructions or Intel AVX instructions has no transition penalty with prior microarchitectures. In Skylake microarchitecture, the SSE block can be executed from a Clean state without the penalty of upper-bits dependency and blend operation.

128-bit Intel AVX instructions zero the upper 128-bits of the destination registers. Therefore, 128-bit and 256-bit Intel AVX instructions can be mixed with no penalty.

Assembly/Compiler Coding Rule 63. (H impact, H generality) *Whenever a 256-bit AVX code block and 128-bit SSE code block might execute in sequence, use the VZERoupper instruction to facilitate a transition to a "Clean" state for the next block to execute from.*

15.3.1 Mixing Intel® AVX and Intel SSE in Function Calls

Intel AVX to Intel SSE transitions can occur unexpectedly when calling functions or returning from functions. For example, if a function that uses 256-bit Intel AVX, calls another function, the callee might be using SSE code. Similarly, after a 256-bit Intel AVX function returns, the caller might be executing Intel SSE code.

Assembly/Compiler Coding Rule 64. (H impact, H generality) Add `VZERoupper` instruction after 256-bit AVX instructions are executed and before any function call that might execute SSE code. Add `VZERoupper` at the end of any function that uses 256-bit AVX instructions.

Example 15-4. Function Calls and AVX/SSE transitions

<pre> __attribute__((noinline)) void SSE_function() { __asm addps xmm1, xmm2 __asm xorps xmm3, xmm4 } __attribute__((noinline)) void AVX_function_no_zeroupper() { __asm vaddps ymm1, ymm2, ymm3 __asm vxorps ymm4, ymm5, ymm6 } __attribute__((noinline)) void AVX_function_with_zeroupper() { __asm vaddps ymm1, ymm2, ymm3 __asm vxorps ymm4, ymm5, ymm6 //add vzeroupper when returning from an AVX function __asm vzeroupper } // Code encounter transition penalty __asm vaddps ymm1, ymm2, ymm3 .. //penalty SSE_function(); AVX_function_no_zeroupper(); //penalty __asm addps xmm1, xmm2 </pre>	<pre> // Code mitigated transition penalty __asm vaddps ymm1, ymm2, ymm3 //add vzeroupper before //calling SSE function from AVX code __asm vzeroupper //no penalty SSE_function(); AVX_function_with_zeroupper(); //no penalty __asm addps xmm1, xmm2 </pre>
---	---

Table 15-2 summarizes a heuristic of the performance impact of using or not using `VZERoupper` to bridge transitions of inter-function calls that changes between AVX code implementation and SSE code.

Table 15-4. Effect of `VZERoupper` with Inter-Function Calls Between AVX and SSE Code

Inter-Function Call	Prior Microarchitectures	Skylake Microarchitecture
With <code>VZERoupper</code>	1X (baseline)	~1
No <code>VZERoupper</code>	< 0.1X	Fraction of baseline

15.4 128-BIT LANE OPERATION AND AVX

256-bit operations in Intel AVX are generally performed in two halves of 128-bit lanes. Most of the 256-bit Intel AVX instructions are defined as in-lane: the destination elements in each lane are calculated using source elements only from the same lane. There are only a few cross-lane instructions, which are described below.

The majority of SSE computational instructions perform computation along vertical slots with each data elements. The 128-bit lanes does not affect porting 128-bit code into 256-bit AVX code. VADDPS is one example of this.

Many 128-bit SSE instruction moves data elements horizontally, e.g. SHUFPS uses an imm8 byte to control the horizontal movement of data elements.

Intel AVX promotes these horizontal 128-bit SIMD instruction in-lane into 256-bit operation by using the same control field within the low 128-bit lane and the high 128-bit lane. For example, the 256-bit VSHUFPS instruction uses a control byte containing 4 control values to select the source location of each destination element in a 128-bit lane. This is shown below.

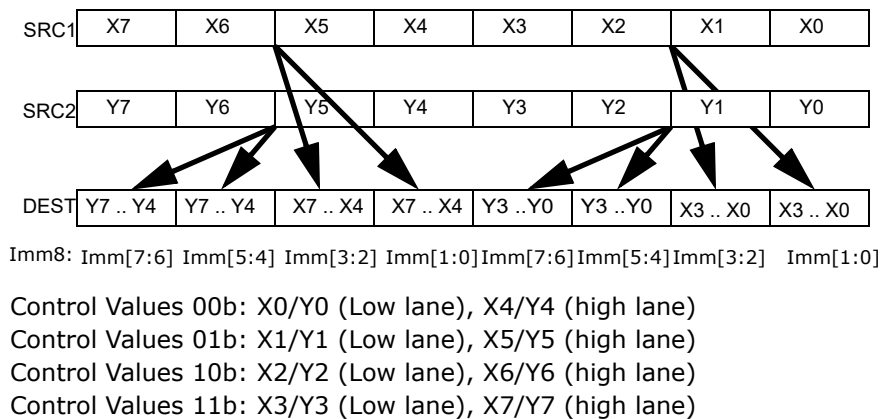

15.4.1 Programming With the Lane Concept

Using the lane concept, algorithms implemented with SSE instruction set can be easily converted to use 256-bit Intel AVX. An SSE algorithm that executes iterations 0 to n can be converted such that the calculation of iteration i is done in the low lane and the calculation of iteration i+k is done in the high lane. For consecutive iterations k equals one.

Some vectorized algorithms implemented with SSE instructions cannot use a simple conversion described above. For example, shuffles that move elements within 16 bytes cannot be naturally converted to shuffles with 32 byte since 32 byte shuffles can't cross lanes.

You can use the following instructions as building blocks for working with lanes:

- VINSERTF128 - insert packed floating-point values.
- VEXTRACTF128 - extract packed floating-point values.
- VPERM2F128 - permute floating-point values.
- VBROADCAST - load with broadcast.

The sections below describe two techniques: the strided loads and the cross register overlap. These methods implement the in lane data arrangement described above and are useful in many algorithms that initially seem to require cross lane calculations.

15.4.2 Strided Load Technique

The strided load technique is a programming method that uses Intel AVX instructions and is useful for algorithms that involve unsupported cross-lane shuffles.

The method describes how to arrange data to avoid cross-lane shuffles. The main idea is to use 128-bit loads in a way that mimics the corresponding Intel SSE algorithm, and enables the 256 Intel AVX instruc-

tions to execute iterations i of the loop in the low lanes and the iteration and $i+k$ in the high lanes. In the following example, k equals one.

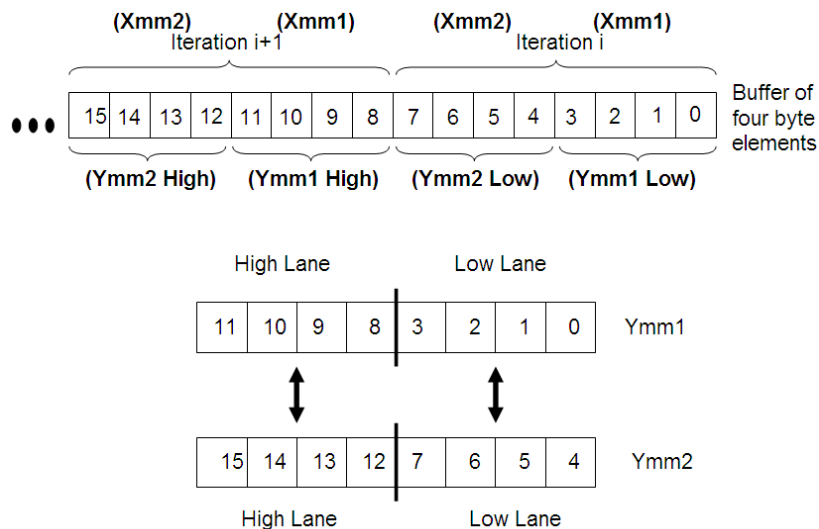

The values in the low lanes of Ymm1 and Ymm2 in the figure above correspond to iteration i in the SSE implementation. Similarly, the values in the high lanes of Ymm1 and Ymm2 correspond to iteration $i+1$.

The following example demonstrates the strided load method in a conversion of an Array of Structures (AoS) to a Structure of Arrays (SoA). In this example, the input buffer contains complex numbers in an AoS format. Each complex number is made of a real and an imaginary float values. The output buffer is arranged as SoA. All the real components of the complex numbers are located at the first half of the output buffer and all the imaginary components are located at the second half of the buffer. The following pseudo code and figure illustrate the conversion:

Example 15-5. AoS to SoA Conversion of Complex Numbers in C Code

```

for (i = 0; i < N; i++)
{
    Real[i] = Complex[i].Real;
    Imaginary[i] = Complex[i].Imaginary;
}
    
```

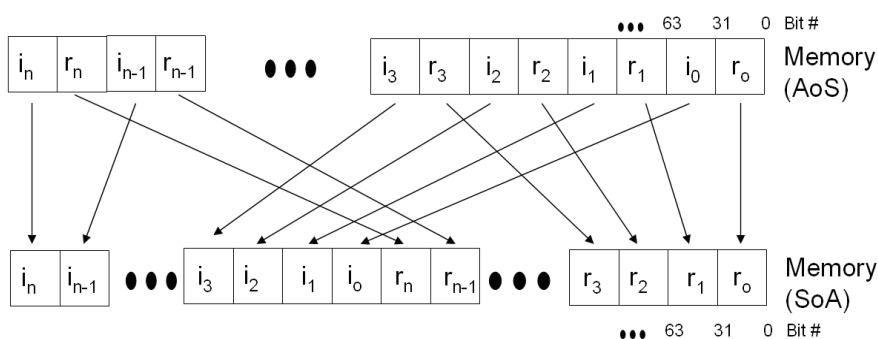

A simple extension of the Intel SSE algorithm from 16-byte to 32-byte operations would require cross-lane data transition, as shown in the following figure. However, this is not possible with Intel AVX architecture and a different technique is required.

The challenge of cross-lane shuffle can be overcome with Intel AVX for AoS to SoA conversion. Using `VINSERTF128` to load 16 bytes to the appropriate lane in the YMM registers obviates the need for cross-lane shuffle. Once the data is organized properly in the YMM registers for step 1, 32-byte `VSHUFPS` can be used to move the data in lanes, as shown in step 2.

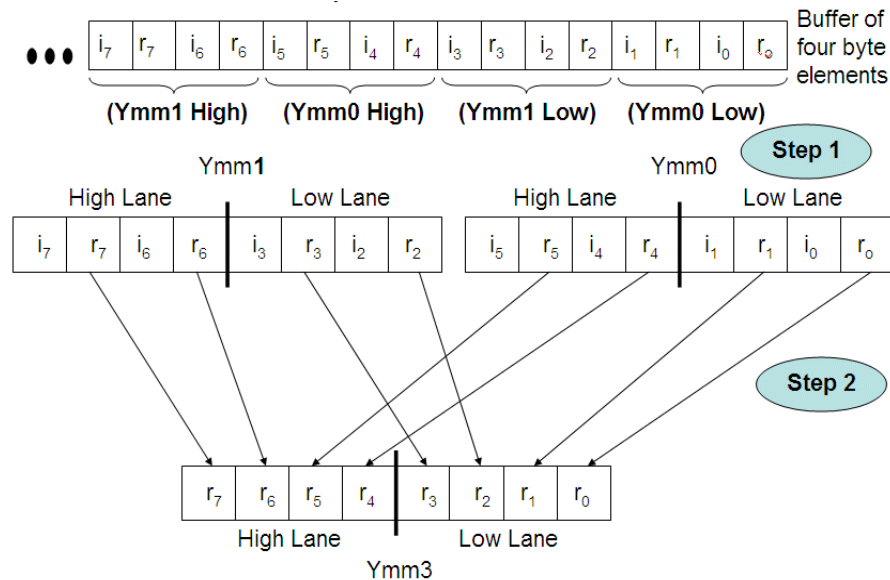

The following code compares the Intel SSE implementation of AoS to SoA with the 256-bit Intel AVX implementation and demonstrates the performance gained.

Example 15-6. Aos to SoA Conversion of Complex Numbers Using AVX

SSE Code	AVX Code
<code>xor rbx, rbx</code>	<code>xor rbx, rbx</code>
<code>xor rdx, rdx</code>	<code>xor rdx, rdx</code>
<code>mov rcx, len</code>	<code>mov rcx, len</code>
<code>mov rdi, inPtr</code>	<code>mov rdi, inPtr</code>
<code>mov rsi, outPtr1</code>	<code>mov rsi, outPtr1</code>
<code>mov rax, outPtr2</code>	<code>mov rax, outPtr2</code>
loop1:	loop1:
<code>movups xmm0, [rdi+rbx]</code>	<code>vmovups xmm0, [rdi+rbx]</code>
<code>//i1 r1 i0 r0</code>	<code>//i1 r1 i0 r0</code>
<code>movups xmm1, [rdi+rbx+16]</code>	<code>vmovups xmm1, [rdi+rbx+16]</code>
<code>// i3 r3 i2 r2</code>	<code>// i3 r3 i2 r2</code>
<code>movups xmm2, xmm0</code>	<code>vinsertf128 ymm0, ymm0, [rdi+rbx+32], 1</code>
	<code>//i5 r5 i4 r4; i1 r1 i0 r0</code>
<code>shufps xmm0, xmm1, 0xdd</code>	<code>vinsertf128 ymm1, ymm1, [rdi+rbx+48], 1</code>
<code>//i3 i2 i1 i0</code>	<code>//i7 r7 i6 r6; i3 r3 i2 r2</code>
<code>shufps xmm2, xmm1, 0x88</code>	<code>vshufps ymm2, ymm0, ymm1, 0xdd</code>
<code>//r3 r2 r1 r0</code>	<code>//i7 i6 i5 i4; i3 i2 i1 i0</code>
	<code>vshufps ymm3, ymm0, ymm1, 0x88</code>
	<code>//r7 r6 r5 r4; r3 r2 r1 r0</code>

Example 15-6. AoS to SoA Conversion of Complex Numbers Using AVX (Contd.)

SSE Code	AVX Code
<code>movups [rax+rdx], xmm0</code>	<code>vmovups [rax+rdx], ymm2</code>
<code>movups [rsi+rdx], xmm2</code>	<code>vmovups [rsi+rdx], ymm3</code>
<code>add rdx, 16</code>	<code>add rdx, 32</code>
<code>add rbx, 32</code>	<code>add rbx, 64</code>
<code>cmp rcx, rbx</code>	<code>cmp rcx, rbx</code>
<code>jnz loop1</code>	<code>jnz loop1</code>

15.4.3 The Register Overlap Technique

The register overlap technique is useful for algorithms that use shuffling. Similar to the strided load technique, the register overlap technique arranges data to avoid cross-lane shuffles.

This technique is useful for algorithm that process continues data, which is partially shared by sequential iterations. The following figure illustrates the desired data layout. This is enabled by using overlapping 256-bit loads, or by using the `VPERM2F128` instruction.

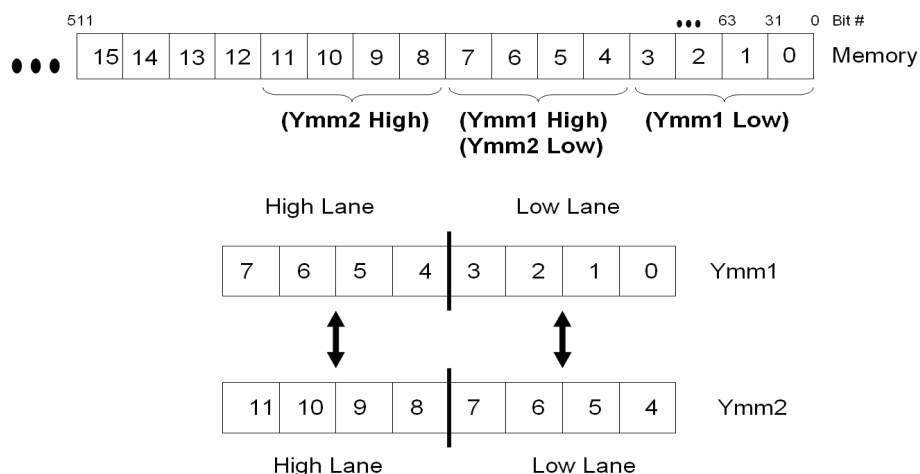

The Median3 code sample below demonstrates the register overlap technique. The median3 technique calculates the median of every three consecutive elements in a vector.

$$Y[i] = \text{Median}(X[i], X[i+1], X[i+2])$$

Where Y is the output vector and X is the input vector. The following figure illustrates the calculation done by the median algorithm.

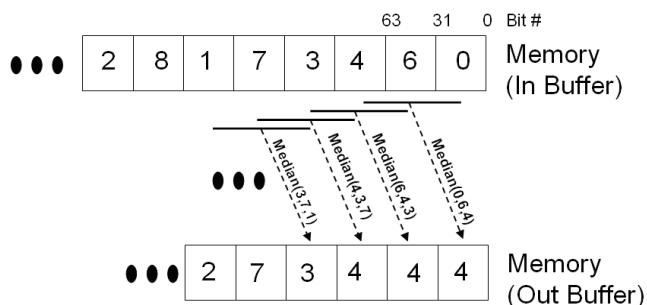

Following are three implementations of the Median3 algorithm. Alternative 1 is the Intel SSE implementation. Alternatives 2 and 3 implement the register overlap technique in two ways. Alternative 2 loads the data from the input buffer into the YMM registers using overlapping 256-bit load operations. Alternative 3 loads the data from the input buffer into the YMM registers using a 256-bit load operation and VPERM2F128. Alternatives 2 and 3 gain performance by using wider vectors.

Example 15-7. Register Overlap Method for Median of 3 Numbers

1: SSE Code	2: 256-bit AVX w/ Overlapping Loads	3: 256-bit AVX with VPERM2F128
<pre>xor ebx, ebx mov rcx, len mov rdi, inPtr mov rsi, outPtr movaps xmm0, [rdi] loop_start: movaps xmm4, [rdi+16] movaps xmm2, [rdi] movaps xmm1, [rdi] movaps xmm3, [rdi] add rdi, 16 add rbx, 4 shufps xmm2, xmm4, 0x4e shufps xmm1, xmm2, 0x99 minps xmm3, xmm1 maxps xmm0, xmm1 minps xmm0, xmm2 maxps xmm0, xmm3 movaps [rsi], xmm0 movaps xmm0, xmm4 add rsi, 16 cmp rbx, rcx jl loop_start</pre>	<pre>xor ebx, ebx mov rcx, len mov rdi, inPtr mov rsi, outPtr vmovaps ymm0, [rdi] loop_start: vshufps ymm2, ymm0, [rdi+16], 0x4E vshufps ymm1, ymm0, ymm2, 0x99 add rbx, 8 add rdi, 32 vminps ymm4, ymm0, ymm1 vmaxps ymm0, ymm0, ymm1 vminps ymm3, ymm0, ymm2 vmaxps ymm5, ymm3, ymm4 vmovaps [rsi], ymm5 add rsi, 32 vmovaps ymm0, [rdi] cmp rbx, rcx jl loop_start</pre>	<pre>xor ebx, ebx mov rcx, len mov rdi, inPtr mov rsi, outPtr vmovaps ymm0, [rdi] loop_start: add rdi, 32 vmovaps ymm6, [rdi] vperm2f128 ymm1, ymm0, ymm6, 0x21 vshufps ymm3, ymm0, ymm1, 0x4E vshufps ymm2, ymm0, ymm3, 0x99 add rbx, 8 vminps ymm5, ymm0, ymm2 vmaxps ymm0, ymm0, ymm2 vminps ymm4, ymm0, ymm3 vmaxps ymm7, ymm4, ymm5 vmovaps ymm0, ymm6 vmovaps [rsi], ymm7 add rsi, 32 cmp rbx, rcx jl loop_start</pre>

15.5 DATA GATHER AND SCATTER

This section describes techniques for implementing data gather and scatter operations using Intel AVX instructions.

15.5.1 Data Gather

The gather operation reads elements from an input buffer based on indexes specified in an index buffer. The gathered elements are written in an output buffer. The following figure illustrates an example for a gather operation.

$$\text{Output}[i] = \text{Input}[\text{Index}[i]]$$

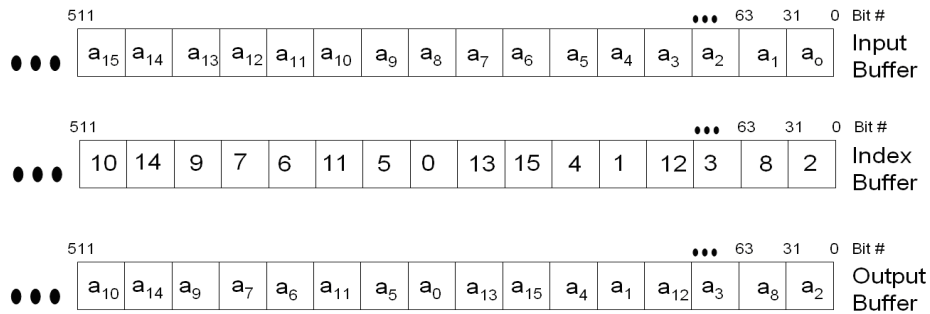

Following are 3 implementations for the gather operation from an array of 4 byte elements. Alternative 1 is a scalar implementation using general purpose registers. Alternative 2 and 3 use Intel AVX instructions. The figure below shows code snippets from Example 15-8 assuming that it runs the first iteration on data from the previous figure.

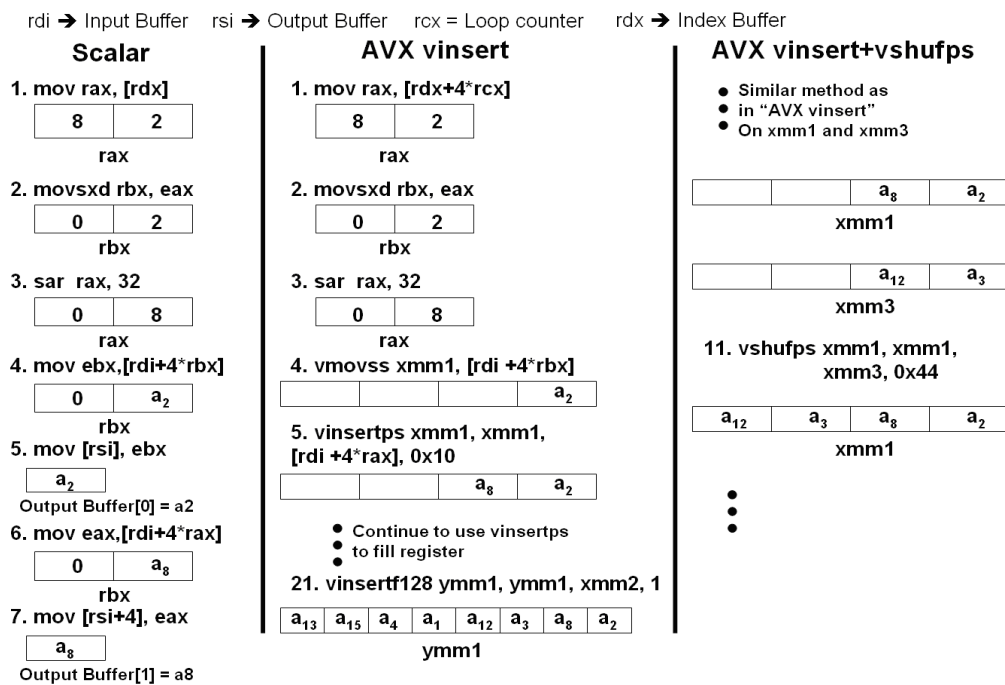

Performance of the Intel AVX examples is similar to the performance of a corresponding Intel SSE implementation. The table below shows the three gather implementations.

Example 15-8. Data Gather - AVX versus Scalar Code

1: Scalar Code	2: AVX w/ VINSERTPS	3: VINSERTPS+VSHUFPS
<pre> mov rdi, InBuf mov rsi, OutBuf mov rdx, Index xor rcx, rcx loop1: mov rax, [rdx] movsxd rbx, eax sar rax, 32 mov ebx, [rdi + 4*rbx] mov [rsi], ebx mov eax, [rdi + 4*rax] mov [rsi + 4], eax mov rax, [rdx + 8] movsxd rbx, eax sar rax, 32 mov ebx, [rdi + 4*rbx] mov [rsi + 8], ebx mov eax, [rdi + 4*rax] mov [rsi + 12], eax mov rax, [rdx + 16] movsxd rbx, eax sar rax, 32 mov ebx, [rdi + 4*rbx] mov [rsi + 16], ebx mov eax, [rdi + 4*rax] mov [rsi + 20], eax mov rax, [rdx + 24] movsxd rbx, eax sar rax, 32 mov ebx, [rdi + 4*rbx] mov [rsi + 24], ebx mov eax, [rdi + 4*rax] mov [rsi + 28], eax add rsi, 32 add rdx, 32 add rcx, 8 cmp rcx, len jl loop1 </pre>	<pre> mov rdi, InBuf mov rsi, OutBuf mov rdx, Index xor rcx, rcx loop1: mov rax, [rdx + 4*rcx] movsxd rbx, eax sar rax, 32 vmovss xmm1, [rdi + 4*rbx] vinsertps xmm1, xmm1, [rdi + 4*rax], 0x10 mov rax, [rdx + 8 + 4*rcx] movsxd rbx, eax sar rax, 32 vinsertps xmm1, xmm1, [rdi + 4*rbx], 0x20 vinsertps xmm1, xmm1, [rdi + 4*rax], 0x30 mov rax, [rdx + 16 + 4*rcx] movsxd rbx, eax sar rax, 32 vmovss xmm2, [rdi + 4*rbx] vinsertps xmm2, xmm2, [rdi + 4*rax], 0x10 mov rax, [rdx + 24 + 4*rcx] movsxd rbx, eax sar rax, 32 vinsertps xmm2, xmm2, [rdi + 4*rbx], 0x20 vinsertps xmm2, xmm2, [rdi + 4*rax], 0x30 vinsertf128 ymm1, ymm1, xmm2, 1 vmovaps [rsi + 4*rcx], ymm1 add rcx, 8 cmp rcx, len jl loop1 </pre>	<pre> mov rdi, InBuf mov rsi, OutBuf mov rdx, Index xor rcx, rcx loop1: mov rax, [rdx + 4*rcx] movsxd rbx, eax sar rax, 32 vmovss xmm1, [rdi + 4*rbx] vinsertps xmm1, xmm1, [rdi + 4*rax], 0x10 mov rax, [rdx + 8 + 4*rcx] movsxd rbx, eax sar rax, 32 vmovss xmm3, [rdi + 4*rbx] vinsertps xmm3, xmm3, [rdi + 4*rax], 0x10 vshufps xmm1, xmm1, xmm3, 0x44 mov rax, [rdx + 16 + 4*rcx] movsxd rbx, eax sar rax, 32 vmovss xmm2, [rdi + 4*rbx] vinsertps xmm2, xmm2, [rdi + 4*rax], 0x10 mov rax, [rdx + 24 + 4*rcx] movsxd rbx, eax sar rax, 32 vmovss xmm4, [rdi + 4*rbx] vinsertps xmm4, xmm4, [rdi + 4*rax], 0x10 vshufps xmm2, xmm2, xmm4, 0x44 vinsertf128 ymm1, ymm1, xmm2, 1 vmovaps [rsi + 4*rcx], ymm1 add rcx, 8 cmp rcx, len jl loop1 </pre>

15.5.2 Data Scatter

The scatter operation reads elements from an input buffer sequentially. It then writes them to an output buffer based on indexes specified in an index buffer. The following figure illustrates an example for a scatter operation.

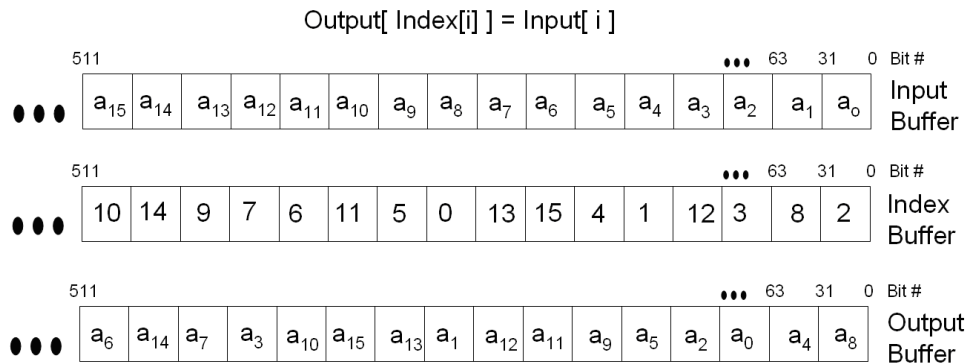

The following table includes a scalar implementation and an Intel AVX implementation of a scatter sequence. The Intel AVX examples consist mainly of 128-bit Intel AVX instructions. Performance of the Intel AVX examples is similar to the performance of corresponding Intel SSE implementation.

Example 15-9. Scatter Operation Using AVX

Scalar Code	AVX Code
<pre> mov rdi, InBuf mov rsi, OutBuf mov rdx, Index xor rcx, rcx loop1: movsxd rax, [rdx] mov ebx, [rdi] mov [rsi + 4*rax], ebx movsxd rax, [rdx + 4] mov ebx, [rdi + 4] mov [rsi + 4*rax], ebx movsxd rax, [rdx + 8] mov ebx, [rdi + 8] mov [rsi + 4*rax], ebx movsxd rax, [rdx + 12] mov ebx, [rdi + 12] mov [rsi + 4*rax], ebx movsxd rax, [rdx + 16] mov ebx, [rdi + 16] mov [rsi + 4*rax], ebx movsxd rax, [rdx + 20] mov ebx, [rdi + 20] mov [rsi + 4*rax], ebx movsxd rax, [rdx + 24] mov ebx, [rdi + 24] </pre>	<pre> mov rdi, InBuf mov rsi, OutBuf mov rdx, Index xor rcx, rcx loop1: vmovaps ymm0, [rdi + 4*rcx] movsxd rax, [rdx + 4*rcx] movsxd rbx, [rdx + 4*rcx + 4] vmovss [rsi + 4*rax], xmm0 movsxd rax, [rdx + 4*rcx + 8] vpalignr xmm1, xmm0, xmm0, 4 vmovss [rsi + 4*rbx], xmm1 movsxd rbx, [rdx + 4*rcx + 12] vpalignr xmm2, xmm0, xmm0, 8 vmovss [rsi + 4*rax], xmm2 movsxd rax, [rdx + 4*rcx + 16] vpalignr xmm3, xmm0, xmm0, 12 vmovss [rsi + 4*rbx], xmm3 movsxd rbx, [rdx + 4*rcx + 20] vextractf128 xmm0, ymm0, 1 vmovss [rsi + 4*rax], xmm0 movsxd rax, [rdx + 4*rcx + 24] vpalignr xmm1, xmm0, xmm0, 4 vmovss [rsi + 4*rbx], xmm1 movsxd rbx, [rdx + 4*rcx + 28] </pre>

Example 15-9. Scatter Operation Using AVX (Contd.)

Scalar Code	AVX Code
<pre> mov [rsi + 4*rax], ebx movsxd rax, [rdx + 28] mov ebx, [rdi + 28] mov [rsi + 4*rax], ebx add rdi, 32 add rdx, 32 add rcx, 8 cmp rcx, len jl loop1 </pre>	<pre> vpsignb xmm2, xmm0, xmm0, 8 vmovss [rsi + 4*rax], xmm2 vpsignb xmm3, xmm0, xmm0, 12 vmovss [rsi + 4*rbx], xmm3 add rcx, 8 cmp rcx, len jl loop1 </pre>

15.6 DATA ALIGNMENT FOR INTEL® AVX

This section explains the benefit of aligning data that is used by Intel AVX instructions and proposes some methods to improve performance when such alignment is not possible. Most examples in this section are variations of the SAXPY kernel. SAXPY is the Scalar Alpha * X + Y algorithm.

The C code below is a C implementation of SAXPY.

```

for (int i = 0; i < n; i++)
{ c[i] = alpha * a[i] + b[i]; }

```

15.6.1 Align Data to 32 Bytes

Aligning data to vector length is recommended. When using 16-byte SIMD instructions, loaded data should be aligned to 16 bytes. Similarly, for best results when using Intel AVX instructions with 32-byte registers align the data to 32-bytes.

When using Intel AVX with unaligned 32-byte vectors, every second load is a cache-line split, since the cache-line is 64 bytes. This doubles the cache line split rate compared to Intel SSE code that uses 16-byte vectors. Even though split line access penalties have been reduced significantly since Nehalem microarchitecture, a high cache-line split rate in memory-intensive code may cause performance degradation.

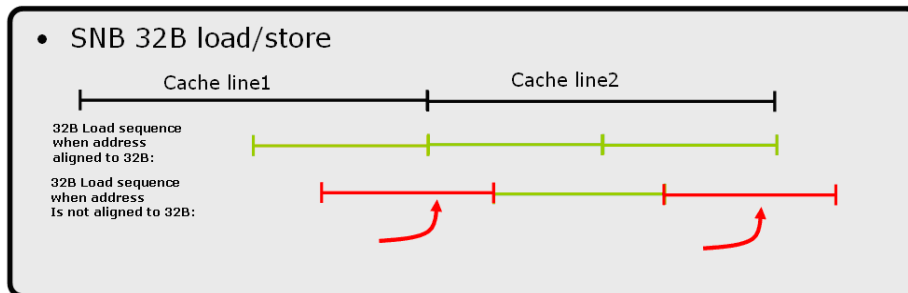

Example 15-10. SAXPY using Intel AVX

```

mov    rax, src1
mov    rbx, src2
mov    rcx, dst
mov    rdx, len
xor    rdi, rdi
vbroadcastss    ymm0, alpha

start_loop:
vmovups    ymm1, [rax + rdi]
vmulps    ymm1, ymm1, ymm0
vmovups    ymm2, [rbx + rdi]
vaddps    ymm1, ymm1, ymm2
vmovups    [rcx + rdi], ymm1
vmovups    ymm1, [rax + rdi + 32]
vmulps    ymm1, ymm1, ymm0
vmovups    ymm2, [rbx + rdi + 32]
vaddps    ymm1, ymm1, ymm2
vmovups    [rcx + rdi + 32], ymm1

add    rdi, 64
cmp    rdi, rdx
jl    start_loop

```

SAXPY is a memory intensive kernel that emphasizes the importance of data alignment. Optimal performance requires both data source address to be 32-byte aligned and destination address also 32-byte aligned. If only one of the three address is not aligned to 32-byte boundary, the performance may be halved. If all three addresses are mis-aligned relative to 32 byte, the performance degrades further. In some cases, unaligned accesses may result in lower performance for Intel AVX code compared to Intel SSE code. Other Intel AVX kernels typically have more computation which can reduce the effect of the data alignment penalty.

Assembly/Compiler Coding Rule 65. (H impact, M generality) *Align data to 32-byte boundary when possible. Prefer store alignment over load alignment.*

You can use dynamic data alignment using the `_mm_malloc` intrinsic instruction with the Intel® Compiler, or `_aligned_malloc` of the Microsoft* Compiler. For example:

```
//dynamically allocating 32byte aligned buffer with 2048 float elements.
```

```
InputBuffer = (float*) _mm_malloc (2048*sizeof(float), 32);
```

You can use static data alignment using `__declspec(align(32))`. For example:

```
//Statically allocating 32byte aligned buffer with 2048 float elements.
```

```
__declspec(align(32)) float InputBuffer[2048];
```

15.6.2 Consider 16-Byte Memory Access when Memory is Unaligned

For best results use Intel AVX 32-byte loads and align data to 32-bytes. However, there are cases where you cannot align the data, or data alignment is unknown. This can happen when you are writing a library function and the input data alignment is unknown. In these cases, using 16-byte memory accesses may be the best alternative. The following method uses 16-byte loads while still benefiting from the 32-byte YMM registers.

NOTE

Beginning with Skylake microarchitecture, this optimization is not necessary. The only case where 16-byte loads may be more efficient is when the data is 16-byte aligned but not 32-byte aligned. In this case 16-byte loads might be preferable as no cache line split memory accesses are issued.

Consider replacing unaligned 32-byte memory accesses using a combination of VMOVUPS, VINSERTF128, and VEXTRACTF128 instructions.

Example 15-11. Using 16-Byte Memory Operations for Unaligned 32-Byte Memory Operation

Convert 32-byte loads as follows:	<code>vmovups ymm0, mem</code>	->	<code>vmovups xmm0, mem</code> <code>vinsertf128 ymm0, ymm0, mem+16, 1</code>
Convert 32-byte stores as follows:	<code>vmovups mem, ymm0</code>	->	<code>vmovups mem, xmm0</code> <code>vextractf128 mem+16, ymm0, 1</code>
The following intrinsics are available to handle unaligned 32-byte memory operating using 16-byte memory accesses:			
<code>_mm256_loadu2_m128 (float const * addr_hi, float const * addr_lo);</code>			
<code>_mm256_loadu2_m128d (double const * addr_hi, double const * addr_lo);</code>			
<code>_mm256_loadu2_m128i (__m128i const * addr_hi, __m128i const * addr_lo);</code>			
<code>_mm256_storeu2_m128 (float * addr_hi, float * addr_lo, __m256 a);</code>			
<code>_mm256_storeu2_m128d (double * addr_hi, double * addr_lo, __m256d a);</code>			
<code>_mm256_storeu2_m128i (__m128i * addr_hi, __m128i * addr_lo, __m256i a);</code>			

Example 15-12 shows two implementations for SAXPY with unaligned addresses. Alternative 1 uses 32-byte loads and alternative 2 uses 16-byte loads. These code samples are executed with two source buffers, `src1`, `src2`, at 4 byte offset from 32-byte alignment, and a destination buffer, `DST`, that is 32-byte aligned. Using two 16-byte memory operations in lieu of 32-byte memory access performs faster.¹

Example 15-12. SAXPY Implementations for Unaligned Data Addresses

AVX with 32-byte memory operation	AVX using two 16-byte memory operations
<code>mov rax, src1</code>	<code>mov rax, src1</code>
<code>mov rbx, src2</code>	<code>mov rbx, src2</code>
<code>mov rcx, dst</code>	<code>mov rcx, dst</code>
<code>mov rdx, len</code>	<code>mov rdx, len</code>
<code>xor rdi, rdi</code>	<code>xor rdi, rdi</code>
<code>vbroadcastss ymm0, alpha</code>	<code>vbroadcastss ymm0, alpha</code>
<code>start_loop:</code>	<code>start_loop:</code>
<code>vmovups ymm1, [rax + rdi]</code>	<code>vmovups xmm2, [rax+rdi]</code>
<code>vmulps ymm1, ymm1, ymm0</code>	<code>vinsertf128 ymm2, ymm2, [rax+rdi+16], 1</code>
<code>vmovups ymm2, [rbx + rdi]</code>	<code>vmulps ymm1, ymm0, ymm2</code>
<code>vaddps ymm1, ymm1, ymm2</code>	<code>vmovups xmm2, [rbx + rdi]</code>
<code>vmovups [rcx + rdi], ymm1</code>	<code>vinsertf128 ymm2, ymm2, [rbx+rdi+16], 1</code>
	<code>vaddps ymm1, ymm1, ymm2</code>

1. Beginning with Haswell microarchitecture and onward, it is better to read the entire register: 32-byte register or 64-byte register (with the availability of Intel® AVX-512).

Example 15-12. SAXPY Implementations for Unaligned Data Addresses (Contd.)

AVX with 32-byte memory operation	AVX using two 16-byte memory operations
<pre> vmovups ymm1, [rax+rdi+32] vmulps ymm1, ymm1, ymm0 vmovups ymm2, [rbx+rdi+32] vaddps ymm1, ymm1, ymm2 vmovups [rcx+rdi+32], ymm1 add rdi, 64 cmp rdi, rdx jl start_loop </pre>	<pre> vmovups [rcx+rdi], ymm1 vmovups xmm2, [rax+rdi+32] vinsertf128 ymm2, ymm2, [rax+rdi+48], 1 vmulps ymm1, ymm0, ymm2 vmovups xmm2, [rbx+rdi+32] vinsertf128 ymm2, ymm2, [rbx+rdi+48], 1 vaddps ymm1, ymm1, ymm2 vmovups [rcx+rdi+32], ymm1 add rdi, 64 cmp rdi, rdx jl start_loop </pre>

Assembly/Compiler Coding Rule 66. (M impact, H generality) Align data to 32-byte boundary when possible. If it is not possible to align both loads and stores, then prefer store alignment over load alignment.

15.6.3 Prefer Aligned Stores Over Aligned Loads

There are cases where it is possible to align only a subset of the processed data buffers. In these cases, aligning data buffers used for store operations usually yields better performance than aligning data buffers used for load operations.

Unaligned stores are likely to cause greater performance degradation than unaligned loads, since there is a very high penalty on stores to a split cache-line that crosses pages. This penalty is estimated at 150 cycles. Stores that cross a page boundary are executed at retirement. In Example 15-12, unaligned store address can affect SAXPY performance for 3 unaligned addresses to about one quarter of the aligned case.

15.7 L1D CACHE LINE REPLACEMENTS

NOTE

Beginning with Haswell microarchitecture, cache line replacement is no longer a concern .

When a load misses the L1D Cache, a cache line with the requested data is brought from a higher memory hierarchy level. In memory intensive code where the L1D Cache is always active, replacing a cache line in the L1D Cache may delay other loads. In Sandy Bridge and Ivy Bridge microarchitectures, the penalty for 32-Byte loads may be higher than the penalty for 16-Byte loads. Therefore, memory intensive Intel AVX code with 32-Byte loads and with data set larger than the L1D Cache may be slower than similar code with 16-Byte loads.

When Example 15-12 is run with a data set that resides in the L2 Cache, the 16-byte memory access implementation is slightly faster than the 32-byte memory operation.

Be aware that the relative merit of 16-byte memory accesses versus 32-byte memory access is implementation specific across generations of microarchitectures.

In Haswell microarchitecture, the L1D Cache can support two 32-byte fetch each cycle.

15.8 4K ALIASING

4-KByte memory aliasing occurs when the code stores to one memory location and shortly after that it loads from a different memory location with a 4-KByte offset between them. For example, a load to linear address 0x400020 follows a store to linear address 0x401020.

The load and store have the same value for bits 5 - 11 of their addresses and the accessed byte offsets should have partial or complete overlap.

4K aliasing may have a five-cycle penalty on the load latency. This penalty may be significant when 4K aliasing happens repeatedly and the loads are on the critical path. If the load spans two cache lines it might be delayed until the conflicting store is committed to the cache. Therefore 4K aliasing that happens on repeated unaligned Intel AVX loads incurs a higher performance penalty.

To detect 4K aliasing, use the `LD_BLOCKS_PARTIAL.ADDRESS_ALIAS` event that counts the number of times Intel AVX loads were blocked due to 4K aliasing.

To resolve 4K aliasing, try the following methods in the following order:

- Align data to 32 Bytes.
- Change offsets between input and output buffers if possible.
- Sandy Bridge and Ivy Bridge microarchitectures may benefit from using 16-Byte memory accesses on memory which is not 32-Byte aligned.

15.9 CONDITIONAL SIMD PACKED LOADS AND STORES

The `VMASKMOV` instruction conditionally moves packed data elements to/from memory, depending on the mask bits associated with each data element. The mask bit for each data element is the most significant bit of the corresponding element in the mask register.

When performing a mask load, the returned value is 0 for elements which have a corresponding mask value of 0. The mask store instruction writes to memory only the elements with a corresponding mask value of 1, while preserving memory values for elements with a corresponding mask value of 0. Faults can occur only for memory accesses that are required by the mask. Faults do not occur due to referencing any memory location if the corresponding mask bit value for that memory location is zero. For example, no faults are detected if the mask bits are all zero.

The following figure shows an example for a mask load and a mask store which does not cause a fault. In this example, the mask register for the load operation is `ymm1` and the mask register for the store operation is `ymm2`.

When using masked load or store consider the following:

- On processors based on microarchitectures prior to Skylake, the address of a `VMASKMOV` store is considered as resolved only after the mask is known. Loads that follow a masked store may be blocked, depending on the memory disambiguation prediction, until the mask value is known.
- If the mask is not all 1 or all 0, loads that depend on the masked store have to wait until the store data is written to the cache. If the mask is all 1 the data can be forwarded from the masked store to the dependent loads. If the mask is all 0 the loads do not depend on the masked store.

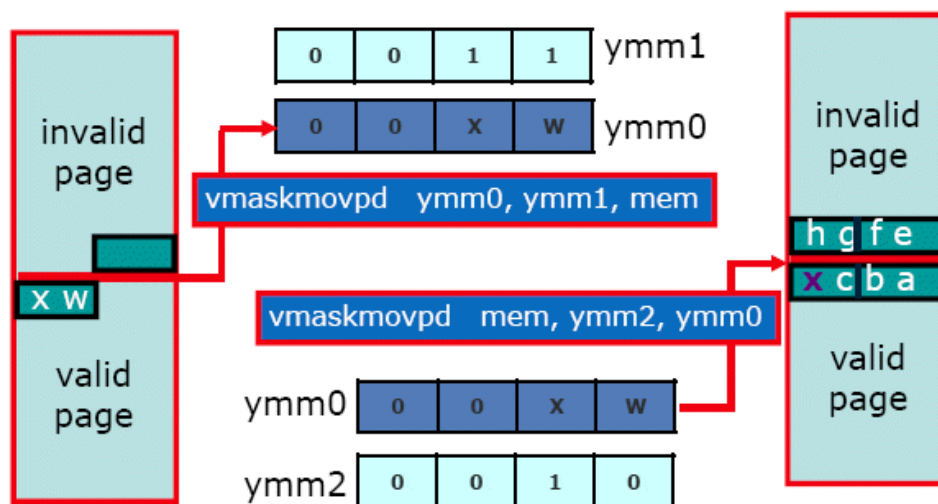

- Masked loads including an illegal address range do not result in an exception if the range is under a zero mask value. However, the processor may take a multi-hundred-cycle “assist” to determine that no part of the illegal range have a one mask value. This assist may occur even when the mask is “zero” and it seems obvious to the programmer that the load should not be executed.

When using VMASKMOV, consider the following:

- Use VMASKMOV only in cases where VMOVUPS cannot be used.
- Use VMASKMOV on 32Byte aligned addresses if possible.
- If possible use valid address range for masked loads, even if the illegal part is masked with zeros.
- Determine the mask as early as possible.
- Avoid store-forwarding issues by performing loads prior to a VMASKMOV store if possible.
- Be aware of mask values that would cause the VMASKMOV instruction to require assist (if an assist is required, the latency of VMASKMOV to load data will increase dramatically):
 - Load data using VMASKMOV with a mask value selecting 0 elements from an illegal address will require an assist.
 - Load data using VMASKMOV with a mask value selecting 0 elements from a legal address expressed in some addressing form (e.g. [base+index], disp[base+index])will require an assist.

With processors based on the Skylake microarchitecture, the performance characteristics of VMASKMOV instructions have the following notable items:

- Loads that follow a masked store is not longer blocked until the mask value is known.
- Store data using VMASKMOV with a mask value permitting 0 elements to be written to an illegal address will require an assist.

15.9.1 Conditional Loops

VMASKMOV enables vectorization of loops that contain conditional code. There are two main benefits in using VMASKMOV over the scalar implementation in these cases:

- VMASKMOV code is vectorized.
- Branch mispredictions are eliminated.

Below is a conditional loop C code:

Example 15-13. Loop with Conditional Expression

```

for(int i = 0; i < miBufferWidth; i++)
{
    if(A[i]>0)
    {
        B[i] = (E[i]*C[i]);
    }
    else
    {
        B[i] = (E[i]*D[i]);
    }
}

```

Example 15-14. Handling Loop Conditional with VMASKMOV

Scalar	AVX using VMASKMOV
<pre> float* pA = A; float* pB = B; float* pC = C; float* pD = D; float* pE = E; uint64 len = (uint64) (miBufferWidth)*sizeof(float); __asm { mov rax, pA mov rbx, pB mov rcx, pC mov rdx, pD mov rsi, pE mov r8, len //xmm8 all zeros vxorps xmm8, xmm8, xmm8 xor r9, r9 loop1: vmovss xmm1, [rax+r9] vcomiss xmm1, xmm8 jbe a_le a_gt: vmovss xmm4, [rcx+r9] jmp mul a_le: vmovss xmm4, [rdx+r9] mul: vmulss xmm4, xmm4, [rsi+r9] vmovss [rbx+r9], xmm4 add r9, 4 cmp r9, r8 jl loop1 } </pre>	<pre> float* pA = A; float* pB = B; float* pC = C; float* pD = D; float* pE = E; uint64 len = (uint64) (miBufferWidth)*sizeof(float); __asm { mov rax, pA mov rbx, pB mov rcx, pC mov rdx, pD mov rsi, pE mov r8, len //ymm8 all zeros vxorps ymm8, ymm8, ymm8 //ymm9 all ones vcmpps ymm9, ymm8, ymm8, 0 xor r9, r9 loop1: vmovups ymm1, [rax+r9] vcmpps ymm2, ymm8, ymm1, 1 vmaskmovps ymm4, ymm2, [rcx+r9] vxorps ymm2, ymm2, ymm9 vmaskmovps ymm5, ymm2, [rdx+r9] vorps ymm4, ymm4, ymm5 vmulps ymm4, ymm4, [rsi+r9] vmovups [rbx+r9], ymm4 add r9, 32 cmp r9, r8 jl loop1 } </pre>

The performance of the left side of Example 15-14 is sensitive to branch mis-predictions and can be an order of magnitude slower than the VMASKMOV example which has no data-dependent branches.

15.10 MIXING INTEGER AND FLOATING-POINT CODE

Integer SIMD functionalities in Intel AVX instructions are limited to 128-bit. There are some algorithm that uses mixed integer SIMD and floating-point SIMD instructions. Therefore, porting such legacy 128-bit code into 256-bit AVX code requires special attention.

For example, PALINGR (Packed Align Right) is an integer SIMD instruction that is useful arranging data elements for integer and floating-point code. But VPALINGR instruction does not have a corresponding 256-bit instruction in AVX.

There are three approaches to consider when porting legacy code consisting of mostly floating-point with some integer operations into 256-bit AVX code:

- Locate a 256-bit AVX alternative to replace the critical 128-bit Integer SIMD instructions if such an AVX instructions exist. This is more likely to be true with integer SIMD instruction that rearranges data elements.
- Mix 128-bit AVX and 256-bit AVX instructions.
- Use Intel AVX2 instructions.

The performance gain from these two approaches may vary. Where possible, use method (1), since this method utilizes the full 256-bit vector width.

In case the code is mostly integer, convert the code from 128-bit SSE to 128 bit AVX instructions and gain from the Non destructive Source (NDS) feature.

Example 15-15. Three-Tap Filter in C Code

```
for(int i = 0; i < len -2; i++)
{
    pOut[i] = A[i]*coeff[0]+A[i+1]*coeff[1]+A[i+2]*coeff[2];
}
```

Example 15-16. Three-Tap Filter with 128-bit Mixed Integer and FP SIMD

```
xor  ebx, ebx
mov   rcx, len
mov   rdi, inPtr
mov   rsi, outPtr
mov   r15, coeffs
movss xmm2, [r15]           // load coeff 0
shufps xmm2, xmm2, 0       // broadcast coeff 0
movss xmm1, [r15+4]        // load coeff 1
shufps xmm1, xmm1, 0       // broadcast coeff 1
movss xmm0, [r15+8]        // coeff 2
shufps xmm0, xmm0, 0       // broadcast coeff 2
movaps xmm5, [rdi]         // xmm5={A[n+3],A[n+2],A[n+1],A[n]}
```

Example 15-16. Three-Tap Filter with 128-bit Mixed Integer and FP SIMD (Contd.)

```

loop_start:
  movaps xmm6, [rdi+16]      // xmm6={A[n+7],A[n+6],A[n+5],A[n+4]}
  movaps xmm7, xmm6
  movaps xmm8, xmm6
  add rdi, 16      // inPtr+=16
  add rbx, 4      // loop counter
  palignr xmm7, xmm5, 4      // xmm7={A[n+4],A[n+3],A[n+2],A[n+1]}
  palignr xmm8, xmm5, 8      // xmm8={A[n+5],A[n+4],A[n+3],A[n+2]}
  mulps xmm5, xmm2      //xmm5={C0*A[n+3],C0*A[n+2],C0*A[n+1], C0*A[n]}

  mulps xmm7, xmm1      // xmm7={C1*A[n+4],C1*A[n+3],C1*A[n+2],C1*A[n+1]}
  mulps xmm8, xmm0      // xmm8={C2*A[n+5],C2*A[n+4], C2*A[n+3],C2*A[n+2]}
  addps xmm7, xmm5
  addps xmm7, xmm8
  movaps [rsi], xmm7
  movaps xmm5, xmm6
  add rsi, 16      // outPtr+=16
  cmp rbx, rcx
  jl loop_start

```

Example 15-17. 256-bit AVX Three-Tap Filter Code with VSHUFPS

```

xor ebx, ebx
mov rcx, len
mov rdi, inPtr
mov rsi, outPtr
mov r15, coeffs
vbroadcastss ymm2, [r15]      // load and broadcast coeff 0
vbroadcastss ymm1, [r15+4]    // load and broadcast coeff 1
vbroadcastss ymm0, [r15+8]    // load and broadcast coeff 2

```

Example 15-17. 256-bit AVX Three-Tap Filter Code with VSHUFPS (Contd.)

```

loop_start:
  vmovaps   ymm5, [rdi]           // Ymm5={A[n+7],A[n+6],A[n+5],A[n+4];
                                  // A[n+3],A[n+2],A[n+1] , A[n]}
  vshufps   ymm6, ymm5, [rdi+16], 0x4e // ymm6={A[n+9],A[n+8],A[n+7],A[n+6];
                                  // A[n+5],A[n+4],A[n+3],A[n+2]}
  vshufps   ymm7, ymm5, ymm6, 0x99 // ymm7={A[n+8],A[n+7],A[n+6],A[n+5];
                                  // A[n+4],A[n+3],A[n+2],A[n+1]}
  vmulps    ymm3, ymm5, ymm2      // ymm3={C0*A[n+7],C0*A[n+6],C0*A[n+5],C0*A[n+4];
                                  // C0*A[n+3],C0*A[n+2],C0*A[n+1],C0*A[n]}
  vmulps    ymm9, ymm7, ymm1      // ymm9={C1*A[n+8],C1*A[n+7],C1*A[n+6],C1*A[n+5];
                                  // C1*A[n+4],C1*A[n+3],C1*A[n+2],C1*A[n+1]}
  vmulps    ymm4, ymm6, ymm0      // ymm4={C2*A[n+9],C2*A[n+8],C2*A[n+7],C2*A[n+6];
                                  // C2*A[n+5],C2*A[n+4],C2*A[n+3],C2*A[n+2]}

  vaddps    ymm8, ymm3, ymm4
  vaddps    ymm10, ymm8, ymm9
  vmovaps   [rsi], ymm10
  add       rdi, 32               // inPtr+=32
  add       rbx, 8                // loop counter
  add       rsi, 32               // outPtr+=32
  cmp      rbx, rcx
  jl       loop_start

```

Example 15-18. Three-Tap Filter Code with Mixed 256-bit AVX and 128-bit AVX Code

```

xor  ebx, ebx
mov  rcx, len
mov  rdi, inPtr
mov  rsi, outPtr
mov  r15, coeffs
vbroadcastss  ymm2, [r15]           // load and broadcast coeff 0
vbroadcastss  ymm1, [r15+4]        // load and broadcast coeff 1
vbroadcastss  ymm0, [r15+8]        // load and broadcast coeff 2
vmovaps   xmm3, [rdi]             // xmm3={A[n+3],A[n+2],A[n+1],A[n]}
loop_start:
  vmovaps   xmm4, [rdi+16]         // xmm4={A[n+7],A[n+6],A[n+5],A[n+4]}
  vmovaps   xmm5, [rdi+32]         // xmm5={A[n+11], A[n+10],A[n+9],A[n+8]}
  vinsertf128  ymm3, ymm3, xmm4, 1 // ymm3={A[n+7],A[n+6],A[n+5],A[n+4];
                                  // A[n+3], A[n+2],A[n+1],A[n]}
  vpsalignr  xmm6, xmm4, xmm3, 4   // xmm6={A[n+4],A[n+3],A[n+2],A[n+1]}
  vpsalignr  xmm7, xmm5, xmm4, 4   // xmm7={A[n+8],A[n+7],A[n+6],A[n+5]}
  vinsertf128  ymm6, ymm6, xmm7, 1 // ymm6={A[n+8],A[n+7],A[n+6],A[n+5];
                                  // A[n+4],A[n+3],A[n+2],A[n+1]}
  vpsalignr  xmm8, xmm4, xmm3, 8   // xmm8={A[n+5],A[n+4],A[n+3],A[n+2]}
  vpsalignr  xmm9, xmm5, xmm4, 8   // xmm9={A[n+9],A[n+8],A[n+7],A[n+6]}
  vinsertf128  ymm8, ymm8, xmm9, 1 // ymm8={A[n+9],A[n+8],A[n+7],A[n+6];
                                  // A[n+5],A[n+4],A[n+3],A[n+2]}
  vmulps    ymm3, ymm3, ymm2      // ymm3={C0*A[n+7],C0*A[n+6],C0*A[n+5], C0*A[n+4];
                                  // C0*A[n+3],C0*A[n+2],C0*A[n+1],C0*A[n]}
  vmulps    ymm6, ymm6, ymm1      // ymm6={C1*A[n+8],C1*A[n+7],C1*A[n+6],C1*A[n+5];
                                  // C1*A[n+4],C1*A[n+3],C1*A[n+2],C1*A[n+1]}

```

Example 15-18. Three-Tap Filter Code with Mixed 256-bit AVX and 128-bit AVX Code (Contd.)

```

vmulps    ymm8, ymm8, ymm0    // ymm8={C2*A[n+9],C2*A[n+8],C2*A[n+7],C2*A[n+6];
                               // C2*A[n+5],C2*A[n+4],C2*A[n+3],C2*A[n+2]}
vaddps    ymm3, ymm3, ymm6
vaddps    ymm3, ymm3, ymm8
vmovaps   [rsi], ymm3
vmovaps   xmm3, xmm5
add    rdi, 32    // inPtr+=32
add    rbx, 8    // loop counter
add    rsi, 32    // outPtr+=32
cmp    rbx, rcx
jl    loop_start

```

Example 15-17 uses 256-bit VSHUFPS to replace the PALIGNR in 128-bit mixed SSE code. This speeds up almost 70% over the 128-bit mixed SSE code of Example 15-16 and slightly ahead of Example 15-18.

For code that includes integer instructions and is written with 256-bit Intel AVX instructions, replace the integer instruction with floating-point instructions that have similar functionality and performance. If there is no similar floating-point instruction, consider using a 128-bit Intel AVX instruction to perform the required integer operation.

15.11 HANDLING PORT 5 PRESSURE

Port 5 in Sandy Bridge microarchitecture includes shuffle units which frequently become a performance bottleneck. Ice Lake Client microarchitecture has added a restricted, in-lane shuffle unit to port 1 to help reduce some of the pressure. Shuffle operations which can be restructured to operate in-lane will benefit from this unit. Sometimes it is possible to replace shuffle instructions that dispatch only on port 5, with different instructions and improve performance by reducing port 5 pressure. For more information, see Table E-11.

15.11.1 Replace Shuffles with Blends

There are a few cases where shuffles such as VSHUFPS or VPERM2F128 can be replaced by blend instructions. Intel AVX shuffles are executed only on port 5, while blends are also executed on port 0. Therefore, replacing shuffles with blends could reduce port 5 pressure. The following figure shows how a VSHUFPS is implemented using VBLENDPS.

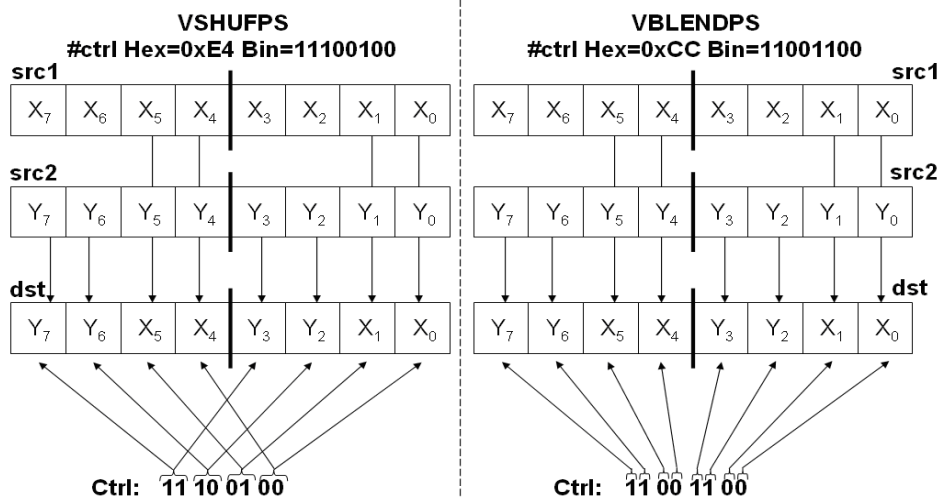

The following example shows two implementations of an 8x8 Matrix transpose. In both cases, the bottleneck is Port 5 pressure. Alternative 1 uses 12 vshufps instructions that are executed only on port 5. Alternative 2 replaces eight of the vshufps instructions with the vblendps instruction which can be executed on Port 0.

Example 15-19. 8x8 Matrix Transpose - Replace Shuffles with Blends

256-bit AVX using VSHUFPS	AVX replacing VSHUFPS with VBLENDPS
<pre> mov rcx, inpBuf mov rdx, outBuf mov r10, NumOfLoops loop1: vmovaps ymm9, [rcx] vmovaps ymm10, [rcx+32] vmovaps ymm11, [rcx+64] vmovaps ymm12, [rcx+96] vmovaps ymm13, [rcx+128] vmovaps ymm14, [rcx+160] vmovaps ymm15, [rcx+192] vmovaps ymm2, [rcx+224] vunpcklps ymm6, ymm9, ymm10 vunpcklps ymm1, ymm11, ymm12 vunpckhps ymm8, ymm9, ymm10 vunpcklps ymm0, ymm13, ymm14 vunpcklps ymm9, ymm15, ymm2 vshufps ymm3, ymm6, ymm1, 0x4E vshufps ymm10, ymm6, ymm3, 0xE4 vshufps ymm6, ymm0, ymm9, 0x4E vunpckhps ymm7, ymm11, ymm12 vshufps ymm11, ymm0, ymm6, 0xE4 </pre>	<pre> mov rcx, inpBuf mov rdx, outBuf mov r10, NumOfLoops loop1: vmovaps ymm9, [rcx] vmovaps ymm10, [rcx+32] vmovaps ymm11, [rcx+64] vmovaps ymm12, [rcx+96] vmovaps ymm13, [rcx+128] vmovaps ymm14, [rcx+160] vmovaps ymm15, [rcx+192] vmovaps ymm2, [rcx+224] vunpcklps ymm6, ymm9, ymm10 vunpcklps ymm1, ymm11, ymm12 vunpckhps ymm8, ymm9, ymm10 vunpcklps ymm0, ymm13, ymm14 vunpcklps ymm9, ymm15, ymm2 vshufps ymm3, ymm6, ymm1, 0x4E vblendps ymm10, ymm6, ymm3, 0xCC vshufps ymm6, ymm0, ymm9, 0x4E vunpckhps ymm7, ymm11, ymm12 vblendps ymm11, ymm0, ymm6, 0xCC </pre>

Example 15-19. 8x8 Matrix Transpose - Replace Shuffles with Blends (Contd.)

256-bit AVX using VSHUFPS	AVX replacing VSHUFPS with VBLENDPS
vshufps ymm12, ymm3, ymm1, 0xE4	vblendps ymm12, ymm3, ymm1, 0xCC
vperm2f128 ymm3, ymm10, ymm11, 0x20	vperm2f128 ymm3, ymm10, ymm11, 0x20
vmovaps [rdx], ymm3	vmovaps [rdx], ymm3
vunpckhps ymm5, ymm13, ymm14	vunpckhps ymm5, ymm13, ymm14
vshufps ymm13, ymm6, ymm9, 0xE4	vblendps ymm13, ymm6, ymm9, 0xCC
vunpckhps ymm4, ymm15, ymm2	vunpckhps ymm4, ymm15, ymm2
vperm2f128 ymm2, ymm12, ymm13, 0x20	vperm2f128 ymm2, ymm12, ymm13, 0x20
vmovaps 32[rdx], ymm2	vmovaps 32[rdx], ymm2
vshufps ymm14, ymm8, ymm7, 0x4E	vshufps ymm14, ymm8, ymm7, 0x4E
vshufps ymm15, ymm14, ymm7, 0xE4	vblendps ymm15, ymm14, ymm7, 0xCC
vshufps ymm7, ymm5, ymm4, 0x4E	vshufps ymm7, ymm5, ymm4, 0x4E
vshufps ymm8, ymm8, ymm14, 0xE4	vblendps ymm8, ymm8, ymm14, 0xCC
vshufps ymm5, ymm5, ymm7, 0xE4	vblendps ymm5, ymm5, ymm7, 0xCC
vperm2f128 ymm6, ymm8, ymm5, 0x20	vperm2f128 ymm6, ymm8, ymm5, 0x20
vmovaps 64[rdx], ymm6	vmovaps 64[rdx], ymm6
vshufps ymm4, ymm7, ymm4, 0xE4	vblendps ymm4, ymm7, ymm4, 0xCC
vperm2f128 ymm7, ymm15, ymm4, 0x20	vperm2f128 ymm7, ymm15, ymm4, 0x20
vmovaps 96[rdx], ymm7	vmovaps 96[rdx], ymm7
vperm2f128 ymm1, ymm10, ymm11, 0x31	vperm2f128 ymm1, ymm10, ymm11, 0x31
vperm2f128 ymm0, ymm12, ymm13, 0x31	vperm2f128 ymm0, ymm12, ymm13, 0x31
vmovaps 128[rdx], ymm1	vmovaps 128[rdx], ymm1
vperm2f128 ymm5, ymm8, ymm5, 0x31	vperm2f128 ymm5, ymm8, ymm5, 0x31
vperm2f128 ymm4, ymm15, ymm4, 0x31	vperm2f128 ymm4, ymm15, ymm4, 0x31
vmovaps 160[rdx], ymm0	vmovaps 160[rdx], ymm0
vmovaps 192[rdx], ymm5	vmovaps 192[rdx], ymm5
vmovaps 224[rdx], ymm4	vmovaps 224[rdx], ymm4
dec r10	dec r10
jnz loop1	jnz loop1

In Example 15-19, replacing VSHUFPS with VBLENDPS relieved port 5 pressure and can gain almost 40% speedup.

Assembly/Compiler Coding Rule 67. (M impact, M generality) Use Blend instructions in lieu of shuffle instruction in AVX whenever possible.

15.11.2 Design Algorithm With Fewer Shuffles

In some cases you can reduce port 5 pressure by changing the algorithm to use less shuffles. The figure below shows that the transpose moved all the elements in rows 0-4 to the low lanes, and all the elements in rows 4-7 to the high lanes. Therefore, using 256-bit loads in the beginning of the algorithm requires using VPERM2F128 in order to swap elements between the lanes. The processor executes the VPERM2F128 instruction only on port 5.

Example 15-19 used eight 256-bit loads and eight VPERM2F128 instructions. You can implement the same 8x8 Matrix Transpose using VINSERTF128 instead of the 256-bit loads and the eight VPERM2F128. Using VINSERTF128 from memory is executed in the load ports and on port 0 or 5. The original method required loads that are performed on the load ports and VPERM2F128 that is only performed on port 5. Therefore redesigning the algorithm to use VINSERTF128 reduces port 5 pressure and improves performance.

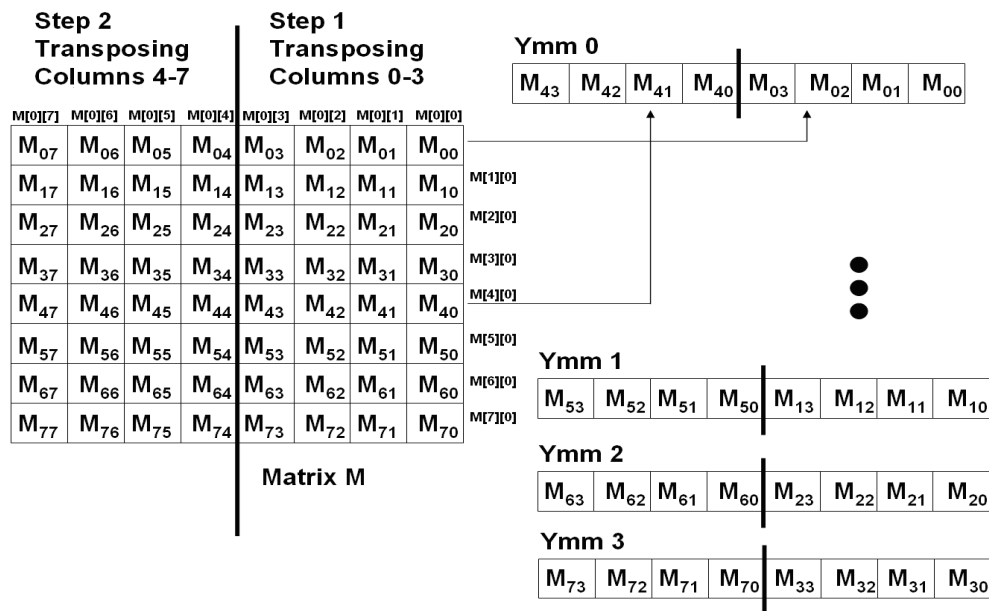

The following figure describes step 1 of the 8x8 matrix transpose with vinsertf128. Step 2 performs the same operations on different columns.

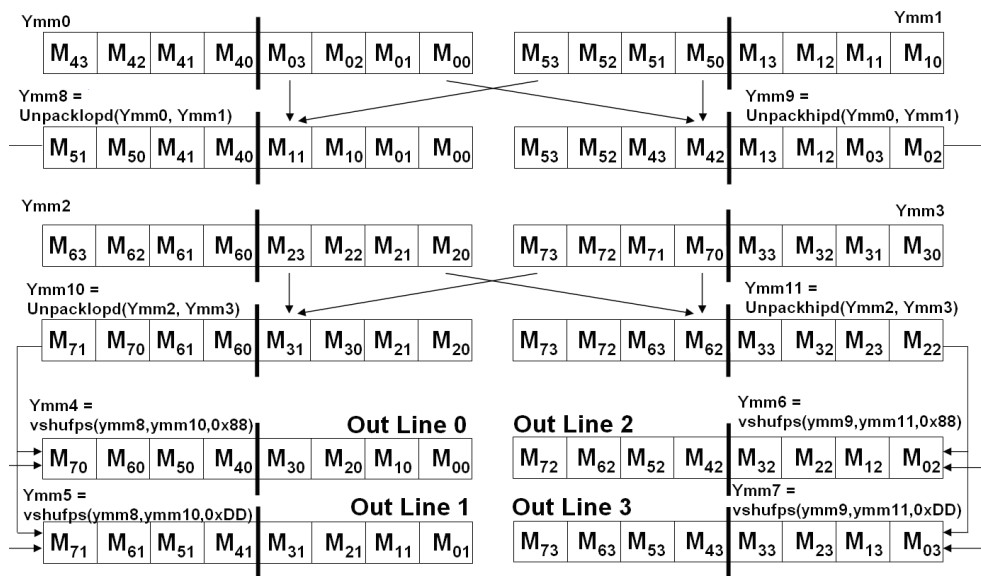

Example 15-20. 8x8 Matrix Transpose Using VINSERTPS

```

mov    rcx, inpBuf
mov    rdx, outBuf
mov    r10, NumOfLoops
loop1:
vmovaps  xmm0, [rcx]
vinsertf128 ymm0, ymm0, [rcx + 128], 1
vmovaps  xmm1, [rcx + 32]
vinsertf128 ymm1, ymm1, [rcx + 160], 1

vunpcklpd  ymm8, ymm0, ymm1
vunpckhpd  ymm9, ymm0, ymm1
vmovaps  xmm2, [rcx+64]
vinsertf128 ymm2, ymm2, [rcx + 192], 1
vmovaps  xmm3, [rcx+96]
vinsertf128 ymm3, ymm3, [rcx + 224], 1
vunpcklpd  ymm10, ymm2, ymm3
vunpckhpd  ymm11, ymm2, ymm3
vshufps  ymm4, ymm8, ymm10, 0x88
vmovaps  [rdx], ymm4
vshufps  ymm5, ymm8, ymm10, 0xDD
vmovaps  [rdx+32], ymm5
vshufps  ymm6, ymm9, ymm11, 0x88
vmovaps  [rdx+64], ymm6
vshufps  ymm7, ymm9, ymm11, 0xDD
vmovaps  [rdx+96], ymm7
vmovaps  xmm0, [rcx+16]
vinsertf128 ymm0, ymm0, [rcx + 144], 1
vmovaps  xmm1, [rcx + 48]
vinsertf128 ymm1, ymm1, [rcx + 176], 1

vunpcklpd  ymm8, ymm0, ymm1
vunpckhpd  ymm9, ymm0, ymm1

vmovaps  xmm2, [rcx+80]
vinsertf128 ymm2, ymm2, [rcx + 208], 1
vmovaps  xmm3, [rcx+112]
vinsertf128 ymm3, ymm3, [rcx + 240], 1

vunpcklpd  ymm10, ymm2, ymm3
vunpckhpd  ymm11, ymm2, ymm3
vshufps  ymm4, ymm8, ymm10, 0x88
vmovaps  [rdx+128], ymm4
vshufps  ymm5, ymm8, ymm10, 0xDD
vmovaps  [rdx+160], ymm5
vshufps  ymm6, ymm9, ymm11, 0x88
vmovaps  [rdx+192], ymm6
vshufps  ymm7, ymm9, ymm11, 0xDD
vmovaps  [rdx+224], ymm7
dec    r10
jnz    loop1

```

In Example 15-20, this reduced port 5 pressure further than the combination of VSHUFPS with VBLENDPS in Example 15-19. It can gain 70% speedup relative to relying on VSHUFPS alone in Example 15-19.

15.11.3 Perform Basic Shuffles on Load Ports

Some shuffles can be executed in the load ports (ports 2, 3) if the source is from memory. The following example shows how moving some shuffles (vmovsldup/vmovshdup) from Port 5 to the load ports improves performance significantly.

The following figure describes an Intel AVX implementation of the complex multiply algorithm with vmovsldup/vmovshdup on the load ports.

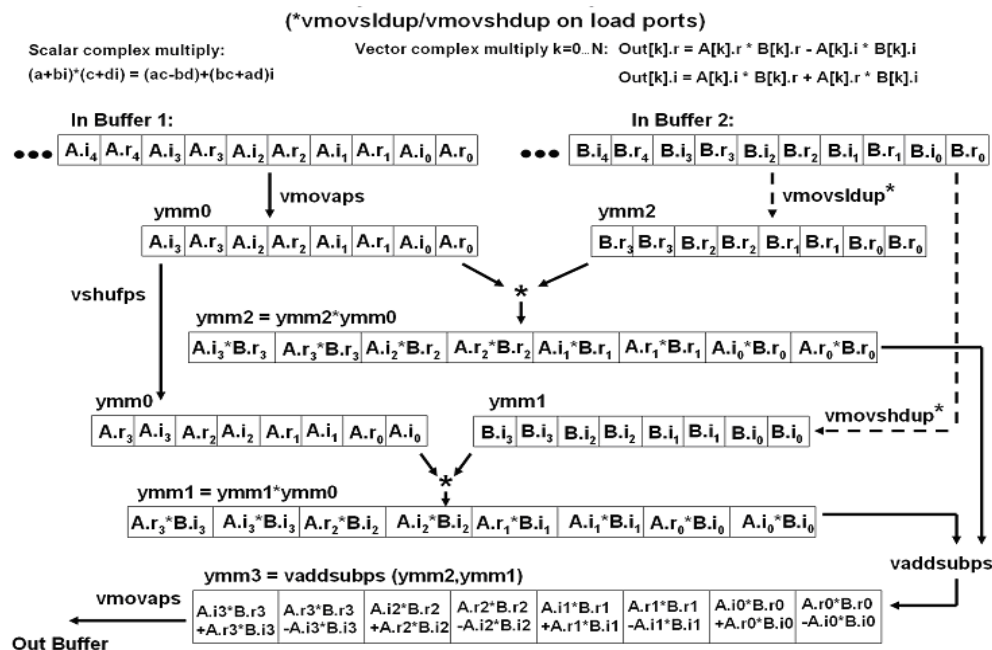

Example 15-21 includes two versions of the complex multiply. Both versions are unrolled twice. Alternative 1 shuffles all the data in registers. Alternative 2 shuffles data while it is loaded from memory.

Example 15-21. Port 5 versus Load Port Shuffles

Shuffles data in registers	Shuffling loaded data
<pre> mov rax, inPtr1 mov rbx, inPtr2 mov rdx, outPtr mov r8, len xor rcx, rcx loop1: vmovaps ymm0, [rax +8*rcx] vmovaps ymm4, [rax +8*rcx +32] vmovaps ymm3, [rbx +8*rcx] vmovsldup ymm2, ymm3 vmulps ymm2, ymm2, ymm0 vshufps ymm0, ymm0, ymm0, 177 vmovshdup ymm1, ymm3 vmulps ymm1, ymm1, ymm0 vmovaps ymm7, [rbx +8*rcx +32] vmovsldup ymm6, ymm7 vmulps ymm6, ymm6, ymm4 vaddsubps ymm2, ymm2, ymm1 vmovshdup ymm5, ymm7 vmovaps [rdx+8*rcx], ymm2 vshufps ymm4, ymm4, ymm4, 177 vmulps ymm5, ymm5, ymm4 vaddsubps ymm6, ymm6, ymm5 vmovaps [rdx+8*rcx+32], ymm6 add rcx, 8 cmp rcx, r8 jl loop1 </pre>	<pre> mov rax, inPtr1 mov rbx, inPtr2 mov rdx, outPtr mov r8, len xor rcx, rcx loop1: vmovaps ymm0, [rax +8*rcx] vmovaps ymm4, [rax +8*rcx +32] vmovsldup ymm2, [rbx +8*rcx] vmulps ymm2, ymm2, ymm0 vshufps ymm0, ymm0, ymm0, 177 vmovshdup ymm1, [rbx +8*rcx] vmulps ymm1, ymm1, ymm0 vmovsldup ymm6, [rbx +8*rcx +32] vmulps ymm6, ymm6, ymm4 vaddsubps ymm3, ymm2, ymm1 vmovshdup ymm5, [rbx +8*rcx +32] vmovaps [rdx +8*rcx], ymm3 vshufps ymm4, ymm4, ymm4, 177 vmulps ymm5, ymm5, ymm4 vaddsubps ymm7, ymm6, ymm5 vmovaps [rdx +8*rcx +32], ymm7 add rcx, 8 cmp rcx, r8 jl loop1 </pre>

15.12 DIVIDE AND SQUARE ROOT OPERATIONS

In Intel microarchitectures prior to Skylake, the SSE divide and square root instructions DIVPS and SQRTPS have a latency of 14 cycles (or the neighborhood) and they are not pipelined. This means that the throughput of these instructions is one in every 14 cycles. The 256-bit Intel AVX instructions VDIVPS and VSQRTPS execute with 128-bit data path and have a latency of 28 cycles and they are not pipelined as well. Therefore, the performance of the Intel SSE divide and square root instructions is similar to the Intel AVX 256-bit instructions on Sandy Bridge microarchitecture.

With the Skylake microarchitecture, 256-bit and 128-bit version of (V)DIVPS/(V)SQRTPS have the same latency because the 256-bit version can execute with a 256-bit data path. The latency is improved and is pipelined to execute with significantly improved throughput. See Appendix D, "Instruction Latency and Throughput".

In microarchitectures that provide DIVPS/SQRTPS with high latency and low throughput, it is possible to speed up single-precision divide and square root calculations using the (V)RSQRTPS and (V)RCPPS instructions. For example, with 128-bit RCPPS/RSQRTPS at 5-cycle latency and 1-cycle throughput or with 256-bit implementation of these instructions at 7-cycle latency and 2-cycle throughput, a single Newton-Raphson iteration or Taylor approximation can achieve almost the same precision as the

(V)DIVPS and (V)SQRTPS instructions. See Intel® 64 and IA-32 Architectures Software Developer's Manual for more information on these instructions.

In some cases, when the divide or square root operations are part of a larger algorithm that hides some of the latency of these operations, the approximation with Newton-Raphson can slow down execution, because more micro-ops, coming from the additional instructions, fill the pipe.

With the Skylake microarchitecture, choosing between approximate reciprocal instruction alternative versus DIVPS/SQRTPS for optimal performance of simple algebraic computations depend on a number of factors. Table 15-5 shows several algebraic formula the throughput comparison of implementations of different numeric accuracy tolerances. In each row, 24-bit accurate implementations are IEEE-compliant and using the respective instructions of 128-bit or 256-bit ISA. The columns of 22-bit and 11-bit accurate implementations are using approximate reciprocal instructions of the respective instruction set.

Table 15-5. Comparison of Numeric Alternatives of Selected Linear Algebra in Skylake Microarchitecture

Algorithm	Instruction Type	24-bit Accurate	22-bit Accurate	11-bit Accurate
$Z = X/Y$	SSE	1X	0.9X	1.3X
	256-bit AVX	1X	1.5X	2.6X
$Z = X^{0.5}$	SSE	1X	0.7X	2X
	256-bit AVX	1X	1.4X	3.4X
$Z = X^{-0.5}$	SSE	1X	1.7X	4.3X
	256-bit AVX	1X	3X	7.7X
$Z = (X * Y + Y * Y)^{0.5}$	SSE	1X	0.75X	0.85X
	256-bit AVX	1X	1.1X	1.6X
$Z = (X+2Y+3)/(Z-2Y-3)$	SSE	1X	0.85X	1X
	256-bit AVX	1X	0.8X	1X

If targeting processors based on the Skylake microarchitecture, Table 15-5 can be summarized as:

- For 256-bit AVX code, Newton-Raphson approximation can be beneficial on Skylake microarchitecture when the algorithm contains only operations executed on the divide unit. However, when single precision divide or square root operations are part of a longer computation, the lower latency of the DIVPS or SQRTPS instructions can lead to better overall performance.
- For SSE or 128-bit AVX implementation, consider use of approximation for divide and square root instructions only for algorithms that do not require precision higher than 11-bit or algorithms that contain multiple operations executed on the divide unit.

Table 15-6 summarizes recommended calculation methods of divisions or square root when using single-precision instructions, based on the desired accuracy level across recent generations of Intel microarchitectures.

Table 15-6. Single-Precision Divide and Square Root Alternatives

Operation	Accuracy Tolerance	Recommendation
Divide	24 bits (IEEE)	DIVPS
	~ 22 bits	Skylake: Consult Table 15-5 Prior uarch: RCPPS + 1 Newton-Raphson Iteration + MULPS
	~ 11 bits	RCPPS + MULPS
Reciprocal square root	24 bits (IEEE)	SQRTPS + DIVPS
	~ 22 bits	RSQRTPS + 1 Newton-Raphson Iteration
	~ 11 bits	RSQRTPS

Table 15-6. Single-Precision Divide and Square Root Alternatives (Contd.)

Operation	Accuracy Tolerance	Recommendation
Square root	24 bits (IEEE)	SQRTPS
	~ 22 bits	Skylake: Consult Table 15-5 Prior uarch: RSQRTPS + 1 Newton-Raphson Iteration + MULPS
	~ 11 bits	RSQRTPS + RCPPS

15.12.1 Single-Precision Divide

To compute:

$$Z[i]=A[i]/B[i]$$

On a large vector of single-precision numbers, $Z[i]$ can be calculated by a divide operation, or by multiplying $1/B[i]$ by $A[i]$.

Denoting $B[i]$ by N , it is possible to calculate $1/N$ using the (V)RCPPS instruction, achieving approximately 11-bit precision.

For better accuracy you can use the one Newton-Raphson iteration:

$$X_{(0)} \sim 1/N \quad ; \text{Initial estimation, rcp}(N)$$

$$X_{(0)} = 1/N*(1-E)$$

$$E=1-N*X_{(0)} \quad ; E \sim 2^{(-11)}$$

$$X_{(1)}=X_{(0)}*(1+E)=1/N*(1-E^2) \quad ; E^2 \sim 2^{(-22)}$$

$$X_{(1)}=X_{(0)}*(1+1-N*X_{(0)})= 2 *X_{(0)} - N*X_{(0)}^2$$

$X_{(1)}$ is an approximation of $1/N$ with approximately 22-bit precision.

Example 15-22. Divide Using DIVPS for 24-bit Accuracy

SSE code using DIVPS	Using VDIVPS
<pre> mov rax, pln1 mov rbx, pln2 mov rcx, pOut mov rsi, iLen xor rdx, rdx loop1: movups xmm0, [rax+rdx*1] movups xmm1, [rbx+rdx*1] divps xmm0, xmm1 movups [rcx+rdx*1], xmm0 add rdx, 16 cmp rdx, rsi jl loop1 </pre>	<pre> mov rax, pln1 mov rbx, pln2 mov rcx, pOut mov rsi, iLen xor rdx, rdx loop1: vmovups ymm0, [rax+rdx*1] vmovups ymm1, [rbx+rdx*1] vdivps ymm0, ymm0, ymm1 vmovups [rcx+rdx*1], ymm0 add rdx, 32 cmp rdx, rsi jl loop1 </pre>

Example 15-23. Divide Using RCPPS 11-bit Approximation

SSE code using RCPPS	Using VRCPPS
<pre> mov rax, pln1 mov rbx, pln2 mov rcx, pOut mov rsi, iLen xor rdx, rdx loop1: movups xmm0,[rax+rdx*1] movups xmm1,[rbx+rdx*1] rcpps xmm1,xmm1 mulps xmm0,xmm1 movups [rcx+rdx*1],xmm0 add rdx, 16 cmp rdx, rsi jl loop1 </pre>	<pre> mov rax, pln1 mov rbx, pln2 mov rcx, pOut mov rsi, iLen xor rdx, rdx loop1: vmovups ymm0, [rax+rdx] vmovups ymm1, [rbx+rdx] vrcpps ymm1, ymm1 vmulps ymm0, ymm0, ymm1 vmovups [rcx+rdx], ymm0 add rdx, 32 cmp rdx, rsi jl loop1 </pre>

Example 15-24. Divide Using RCPPS and Newton-Raphson Iteration

RCPPS + MULPS ~ 22 bit accuracy	VRCPPS + VMULPS ~ 22 bit accuracy
<pre> mov rax, pln1 mov rbx, pln2 mov rcx, pOut mov rsi, iLen xor rdx, rdx loop1: movups xmm0, [rax+rdx*1] movups xmm1, [rbx+rdx*1] rcpps xmm3, xmm1 movaps xmm2, xmm3 addps xmm3, xmm2 mulps xmm2, xmm2 mulps xmm2, xmm1 subps xmm3, xmm2 mulps xmm0, xmm3 movups [rcx+rdx*1], xmm0 add rdx, 16 cmp rdx, rsi jl loop1 </pre>	<pre> mov rax, pln1 mov rbx, pln2 mov rcx, pOut mov rsi, iLen xor rdx, rdx loop1: vmovups ymm0, [rax+rdx] vmovups ymm1, [rbx+rdx] vrcpps ymm3, ymm1 vaddps ymm2, ymm3, ymm3 vmulps ymm3, ymm3, ymm3 vmulps ymm3, ymm3, ymm1 vsubps ymm2, ymm2, ymm3 vmulps ymm0, ymm0, ymm2 vmovups [rcx+rdx], ymm0 add rdx, 32 cmp rdx, rsi jl loop1 </pre>

15.12.2 Single-Precision Reciprocal Square Root

To compute $Z[i]=1/(A[i])^{0.5}$ on a large vector of single-precision numbers, denoting $A[i]$ by N , it is possible to calculate $1/N$ using the (V)RSQRTPS instruction.

For better accuracy you can use one Newton-Raphson iteration:

$X_0 \approx 1/N$; Initial estimation RCP(N)

$E = 1 - N * X_0^2$

$X_0 = (1/N)^{0.5} * ((1-E)^{0.5}) = (1/N)^{0.5} * (1-E/2)$; $E/2 \approx 2^{-11}$

$X_1 = X_0 * (1 + E/2) \approx (1/N)^{0.5} * (1 - E^2/4)$; $E^2/4 \approx 2^{-22}$

$X_1 = X_0 * (1 + 1/2 - 1/2 * N * X_0^2) = 1/2 * X_0 * (3 - N * X_0^2)$

X1 is an approximation of $(1/N)^{0.5}$ with approximately 22-bit precision.

Example 15-25. Reciprocal Square Root Using DIVPS+SQRTPS for 24-bit Accuracy

Using SQRTPS, DIVPS	Using VSQRTPS, VDIVPS
<pre> mov rax, pln mov rbx, pOut mov rcx, iLen xor rdx, rdx loop1: movups xmm1, [rax+rdx] sqrtps xmm0, xmm1 divps xmm0, xmm1 movups [rbx+rdx], xmm0 add rdx, 16 cmp rdx, rcx jl loop1 </pre>	<pre> mov rax, pln mov rbx, pOut mov rcx, iLen xor rdx, rdx loop1: vmovups ymm1, [rax+rdx] vsqrtps ymm0, ymm1 vdivps ymm0, ymm0, ymm1 vmovups [rbx+rdx], ymm0 add rdx, 32 cmp rdx, rcx jl loop1 </pre>

Example 15-26. Reciprocal Square Root Using RSQRTPS 11-bit Approximation

SSE code using RSQRTPS	Using VRSQRTPS
<pre> mov rax, pln mov rbx, pOut mov rcx, iLen xor rdx, rdx loop1: rsqrtps xmm0, [rax+rdx] movups [rbx+rdx], xmm0 add rdx, 16 cmp rdx, rcx jl loop1 </pre>	<pre> mov rax, pln mov rbx, pOut mov rcx, iLen xor rdx, rdx loop1: vrsqrtps ymm0, [rax+rdx] vmovups [rbx+rdx], ymm0 add rdx, 32 cmp rdx, rcx jl loop1 </pre>

Example 15-27. Reciprocal Square Root Using RSQRTPS and Newton-Raphson Iteration

RSQRTPS + MULPS ~ 22 bit accuracy	VRSQRTPS + VMULPS ~ 22 bit accuracy
<pre> __declspec(align(16)) float minus_half[4] = {-0.5, -0.5, - 0.5, -0.5}; __declspec(align(16)) float three[4] = {3.0, 3.0, 3.0, 3.0}; __asm { mov rax, pln mov rbx, pOut mov rcx, iLen xor rdx, rdx movups xmm3, [three] movups xmm4, [minus_half] loop1: movups xmm5, [rax+rdx] rsqrtps xmm0, xmm5 movaps xmm2, xmm0 mulps xmm0, xmm0 mulps xmm0, xmm5 subps xmm0, xmm3 mulps xmm0, xmm2 mulps xmm0, xmm4 movups [rbx+rdx], xmm0 add rdx, 16 cmp rdx, rcx jl loop1 } </pre>	<pre> __declspec(align(32)) float half[8] = {0.5, 0.5, 0.5, 0.5, 0.5, 0.5, 0.5, 0.5}; __declspec(align(32)) float three[8] = {3.0, 3.0, 3.0, 3.0, 3.0, 3.0, 3.0, 3.0}; __asm { mov rax, pln mov rbx, pOut mov rcx, iLen xor rdx, rdx vmovups ymm3, [three] vmovups ymm4, [half] loop1: vmovups ymm5, [rax+rdx] vrsqrtps ymm0, ymm5 vmulps ymm2, ymm0, ymm0 vmulps ymm2, ymm2, ymm5 vsubps ymm2, ymm3, ymm2 vmulps ymm0, ymm0, ymm2 vmulps ymm0, ymm0, ymm4 vmovups [rbx+rdx], ymm0 add rdx, 32 cmp rdx, rcx jl loop1 } </pre>

15.12.3 Single-Precision Square Root

To compute $Z[i] = (A[i])^{0.5}$ on a large vector of single-precision numbers, denoting $A[i]$ by N , the approximation for $N^{0.5}$ is N multiplied by $(1/N)^{0.5}$, where the approximation for $(1/N)^{0.5}$ is described in the previous section.

To get approximately 22-bit precision of $N^{0.5}$, use the following calculation:

$$N^{0.5} = X_1 * N = 1/2 * N * X_0 * (3 - N * X_0^2)$$

Example 15-28. Square Root Using SQRTPS for 24-bit Accuracy

Using SQRTPS	Using VSQRTPS
<pre> mov rax, pln mov rbx, pOut mov rcx, iLen xor rdx, rdx loop1: movups xmm1, [rax+rdx] sqrtps xmm1, xmm1 movups [rbx+rdx], xmm1 add rdx, 16 cmp rdx, rcx jl loop1 </pre>	<pre> mov rax, pln mov rbx, pOut mov rcx, iLen xor rdx, rdx loop1: vmovups ymm1, [rax+rdx] vsqrtps ymm1, ymm1 vmovups [rbx+rdx], ymm1 add rdx, 32 cmp rdx, rcx jl loop1 </pre>

Example 15-29. Square Root Using RSQRTPS 11-bit Approximation

SSE code using RSQRTPS	Using VRSQRTPS
<pre> mov rax, pln mov rbx, pOut mov rcx, iLen xor rdx, rdx loop1: movups xmm1, [rax+rdx] xorps xmm8, xmm8 cmpneqps xmm8, xmm1 rsqrtps xmm1, xmm1 rcpps xmm1, xmm1 andps xmm1, xmm8 movups [rbx+rdx], xmm1 add rdx, 16 cmp rdx, rcx jl loop1 </pre>	<pre> mov rax, pln mov rbx, pOut mov rcx, iLen xor rdx, rdx vxorps ymm8, ymm8, ymm8 loop1: vmovups ymm1, [rax+rdx] vcmpneqps ymm9, ymm8, ymm1 vrsqrtps ymm1, ymm1 vrcpps ymm1, ymm1 vandps ymm1, ymm1, ymm9 vmovups [rbx+rdx], ymm1 add rdx, 32 cmp rdx, rcx jl loop1 </pre>

Example 15-30. Square Root Using RSQRTPS and One Taylor Series Expansion

RSQRTPS + Taylor ~ 22 bit accuracy	VRSQRTPS + Taylor ~ 22 bit accuracy
<pre> __declspec(align(16)) float minus_half[4] = {-0.5, -0.5, -0.5, -0.5}; __declspec(align(16)) float three[4] = {3.0, 3.0, 3.0, 3.0}; __asm { mov rax, pln mov rbx, pOut mov rcx, iLen xor rdx, rdx movups xmm6, [three] movups xmm7, [minus_half] loop1: movups xmm3, [rax+rdx] rsqrtps xmm1, xmm3 xorps xmm8, xmm8 cmpneqps xmm8, xmm3 andps xmm1, xmm8 movaps xmm4, xmm1 mulps xmm1, xmm3 movaps xmm5, xmm1 mulps xmm1, xmm4 subps xmm1, xmm6 mulps xmm1, xmm5 mulps xmm1, xmm7 movups [rbx+rdx], xmm1 add rdx, 16 cmp rdx, rcx jl loop1 } </pre>	<pre> __declspec(align(32)) float three[8] = {3.0, 3.0, 3.0, 3.0, 3.0, 3.0, 3.0, 3.0}; __declspec(align(32)) float minus_half[8] = {-0.5, -0.5, -0.5, -0.5, -0.5, -0.5, -0.5, -0.5}; __asm { mov rax, pln mov rbx, pOut mov rcx, iLen xor rdx, rdx vmovups ymm6, [three] vmovups ymm7, [minus_half] vxorps ymm8, ymm8, ymm8 loop1: vmovups ymm3, [rax+rdx] vrsqrtps ymm4, ymm3 vcmpneqps ymm9, ymm8, ymm3 vandps ymm4, ymm4, ymm9 vmulps ymm1, ymm4, ymm3 vmulps ymm2, ymm1, ymm4 vsubps ymm2, ymm2, ymm6 vmulps ymm1, ymm1, ymm2 vmulps ymm1, ymm1, ymm7 vmovups [rbx+rdx], ymm1 add rdx, 32 cmp rdx, rcx jl loop1 } </pre>

15.13 OPTIMIZATION OF ARRAY SUB SUM EXAMPLE

This section shows the transformation of SSE implementation of Array Sub Sum algorithm to Intel AVX implementation.

The Array Sub Sum algorithm is:

$$Y_{[i]} = \text{Sum of } k \text{ from } 0 \text{ to } i (X_{[k]}) = X_{[0]} + X_{[1]} + \dots + X_{[i]}$$

The following figure describes the SSE implementation.

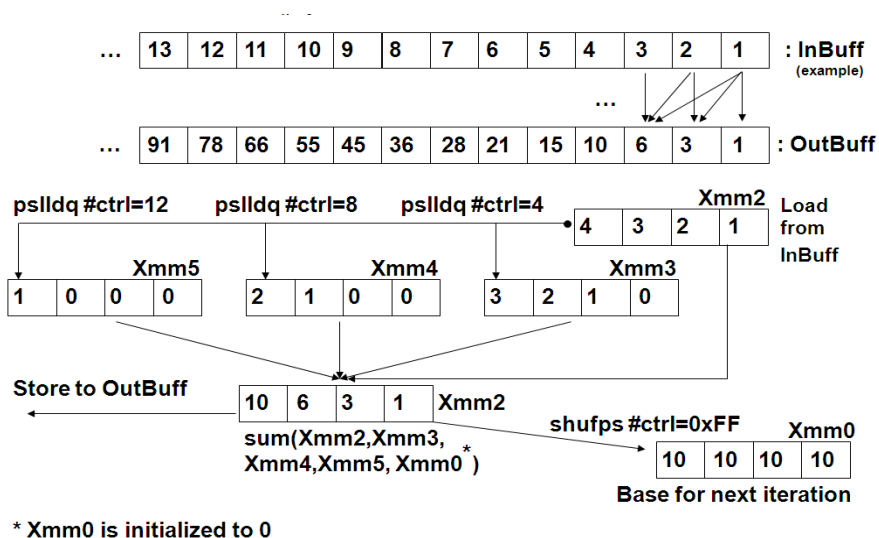

The figure below describes the Intel AVX implementation of the Array Sub Sums algorithm. The PSLLDQ is an integer SIMD instruction which does not have an AVX equivalent. It is replaced by VSHUFPS.

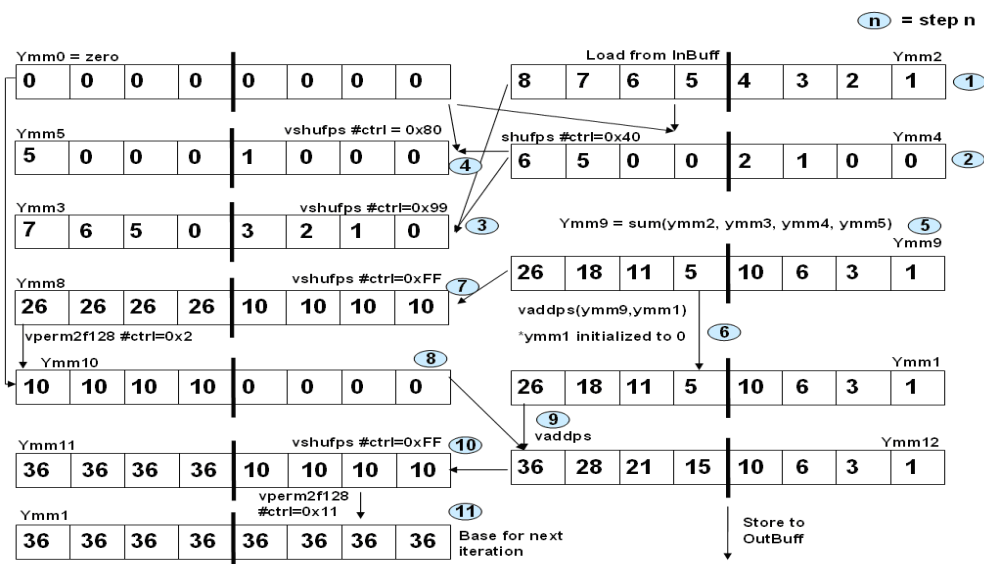

Example 15-31. Array Sub Sums Algorithm

SSE code	AVX code
mov rax, InBuff	mov rax, InBuff
mov rbx, OutBuff	mov rbx, OutBuff
mov rdx, len	mov rdx, len
xor rcx, rcx	xor rcx, rcx
xorps xmm0, xmm0	vxorps ymm0, ymm0, ymm0
	vxorps ymm1, ymm1, ymm1
loop1:	loop1:
movaps xmm2, [rax+4*rcx]	vmovaps ymm2, [rax+4*rcx]
movaps xmm3, xmm2	vshufps ymm4, ymm0, ymm2, 0x40
movaps xmm4, xmm2	vshufps ymm3, ymm4, ymm2, 0x99
movaps ymm5, ymm2	vshufps ymm5, ymm0, ymm4, 0x80
pslldq xmm3, 4	vaddps ymm6, ymm2, ymm3
pslldq xmm4, 8	vaddps ymm7, ymm4, ymm5
pslldq xmm5, 12	vaddps ymm9, ymm6, ymm7
addps xmm2, xmm3	vaddps ymm1, ymm9, ymm1
addps xmm4, xmm5	vshufps ymm8, ymm9, ymm9, 0xff
addps ymm2, xmm4	vperm2f128 ymm10, ymm8, ymm0, 0x2
addps xmm2, xmm0	vaddps ymm12, ymm1, ymm10
movaps xmm0, ymm2	vshufps ymm11, ymm12, ymm12, 0xff
shufps xmm0, xmm2, 0xFF	vperm2f128 ymm1, ymm11, ymm11, 0x11
movaps [rbx+4*rcx], xmm2	vmovaps [rbx+4*rcx], ymm12
add rcx, 4	add rcx, 8
cmp rcx, rdx	cmp rcx, rdx
jl loop1	jl loop1

Example 15-31 shows SSE implementation of array sub `sum` and AVX implementation. The AVX code is about 40% faster.

15.14 HALF-PRECISION FLOATING-POINT CONVERSIONS

In applications that use floating-point and require only the dynamic range and precision offered by the 16-bit floating-point format, storing persistent floating-point data encoded in 16-bits has strong advantages in memory footprint and bandwidth conservation. These situations are encountered in some graphics and imaging workloads.

The encoding format of half-precision floating-point numbers can be found in Chapter 4, “Data Types” of *Intel® 64 and IA-32 Architectures Software Developer’s Manual, Volume 1*.

Instructions to convert between packed, half-precision floating-point numbers and packed single-precision floating-point numbers is described in Chapter 14, “Programming with AVX, FMA and AVX2” of *Intel® 64 and IA-32 Architectures Software Developer’s Manual, Volume 1* and in the reference pages of *Intel® 64 and IA-32 Architectures Software Developer’s Manual, Volume 2B*.

To perform computations on half precision floating-point data, packed 16-bit FP data elements must be converted to single precision format first, and the single-precision results converted back to half precision format, if necessary. These conversions of 8 data elements using 256-bit instructions are very fast and handle the special cases of denormal numbers, infinity, zero and NaNs properly.

15.14.1 Packed Single-Precision to Half-Precision Conversion

To convert the data in single precision floating-point format to half precision format, without special hardware support like VCVTSP2PH, a programmer needs to do the following:

- Correct exponent bias to permitted range for each data element.
- Shift and round the significand of each data element.
- Copy the sign bit to bit 15 of each element.
- Take care of numbers outside the half precision range.
- Pack each data element to a register of half size.

Example 15-32 compares two implementations of floating-point conversion from single precision to half precision. The code on the left uses packed integer shift instructions that is limited to 128-bit SIMD instruction set. The code on right is unrolled twice and uses the VCVTSP2PH instruction.

Example 15-32. Single-Precision to Half-Precision Conversion

AVX-128 code	VCVTSP2PH code
<pre> __asm { mov rax, pln mov rbx, pOut mov rcx, bufferSize add rcx, rax vmovdqu xmm0, SignMask16 vmovdqu xmm1, ExpBiasFixAndRound vmovdqu xmm4, SignMaskNot32 vmovdqu xmm5, MaxConvertibleFloat vmovdqu xmm6, MinFloat loop: vmovdqu xmm2, [rax] vmovdqu xmm3, [rax+16] vpadd xmm7, xmm2, xmm1 vpadd xmm9, xmm3, xmm1 vpand xmm7, xmm7, xmm4 vpand xmm9, xmm9, xmm4 add rax, 32 vminps xmm7, xmm7, xmm5 vminps xmm9, xmm9, xmm5 vpcmpgtd xmm8, xmm7, xmm6 vpcmpgtd xmm10, xmm9, xmm6 vpand xmm7, xmm8, xmm7 vpand xmm9, xmm10, xmm9 vpackssdw xmm2, xmm3, xmm2 vpsrad xmm7, xmm7, 13 vpsrad xmm8, xmm9, 13 vpand xmm2, xmm2, xmm0 vpackssdw xmm3, xmm7, xmm9 vpaddw xmm3, xmm3, xmm2 vmovdqu [rbx], xmm3 add rbx, 16 cmp rax, rcx jl loop </pre>	<pre> __asm { mov rax, pln mov rbx, pOut mov rcx, bufferSize add rcx, rax loop: vmovups ymm0, [rax] vmovups ymm1, [rax+32] add rax, 64 vcvtps2ph [rbx], ymm0, roundingCtrl vcvtps2ph [rbx+16], ymm1, roundingCtrl add rbx, 32 cmp rax, rcx jl loop </pre>

The code using VCVTSP2PH is approximately four times faster than the AVX-128 sequence. Although it is possible to load 8 data elements at once with 256-bit AVX, most of the per-element conversion operations require packed integer instructions which do not have 256-bit extensions yet. Using VCVTSP2PH is not only faster but also provides handling of special cases that do not encode to normal half-precision floating-point values.

15.14.2 Packed Half-Precision to Single-Precision Conversion

Example 15-33 compares two implementations using AVX-128 code and with VCVTPH2PS.

Conversion from half precision to single precision floating-point format is easier to implement, yet using VCVTPH2PS instruction performs about 2.5 times faster than the alternative AVX-128 code.

Example 15-33. Half-Precision to Single-Precision Conversion

AVX-128 code	VCVTSP2PH code
<pre> __asm { mov rax, pln mov rbx, pOut mov rcx, bufferSize add rcx, rax vmovdqu xmm0, SignMask16 vmovdqu xmm1, ExpBiasFix16 vmovdqu xmm2, ExpMaskMarker loop: vmovdqu xmm3, [rax] add rax, 16 vpandn xmm4, xmm0, xmm3 vpand xmm5, xmm3, xmm0 vpsrlw xmm4, xmm4, 3 vpaddw xmm6, xmm4, xmm1 vpcmpgtw xmm7, xmm6, xmm2 vpand xmm6, xmm6, xmm7 vpand xmm8, xmm3, xmm7 vpor xmm6, xmm6, xmm5 vpsllw xmm8, xmm8, 13 vpunpcklwd xmm3, xmm8, xmm6 vpunpckhwd xmm4, xmm8, xmm6 vmovdqu [rbx], xmm3 vmovdqu [rbx+16], xmm4 add rbx, 32 cmp rax, rcx jl loop </pre>	<pre> __asm { mov rax, pln mov rbx, pOut mov rcx, bufferSize add rcx, rax loop: vcvtph2ps ymm0, [rax] vcvtph2ps ymm1, [rax+16] add rax, 32 vmovups [rbx], ymm0 vmovups [rbx+32], ymm1 add rbx, 64 cmp rax, rcx jl loop </pre>

15.14.3 Locality Consideration for using Half-Precision FP to Conserve Bandwidth

Example 15-32 and Example 15-33 demonstrate the performance advantage of using FP16C instructions when software needs to convert between half-precision and single-precision data. Half-precision FP format is more compact, consumes less bandwidth than single-precision FP format, but sacrifices dynamic range, precision, and incurs conversion overhead if arithmetic computation is required. Whether it is profitable for software to use half-precision data will be highly dependent on locality considerations of the workload.

This section uses an example based on the horizontal median filtering algorithm, “Median3”. The Median3 algorithm calculates the median of every three consecutive elements in a vector:

$$Y[i] = \text{Median3}(X[i], X[i+1], X[i+2])$$

Where: Y is the output vector, and X is the input vector.

Example 15-34 shows two implementations of the Median3 algorithm; one uses single-precision format without conversion, the other uses half-precision format and requires conversion. Alternative 1 on the left works with single precision format using 256-bit load/store operations, each of which loads/stores eight 32-bit numbers. Alternative 2 uses 128-bit load/store operations to load/store eight 16-bit numbers in half precision format and VCVTPH2PS/VCVTPS2PH instructions to convert it to/from single precision floating-point format.

Example 15-34. Performance Comparison of Median3 using Half-Precision vs. Single-Precision

Single-Precision code w/o Conversion	Half-Precision code w/ Conversion
<pre> xor rbx, rbx mov rcx, len mov rdi, inPtr mov rsi, outPtr vmovaps ymm0, [rdi] loop: add rdi, 32 vmovaps ymm6, [rdi] vperm2f128 ymm1, ymm0, ymm6, 0x21 vshufps ymm3, ymm0, ymm1, 0x4E vshufps ymm2, ymm0, ymm3, 0x99 vminps ymm5, ymm0, ymm2 vmaxps ymm0, ymm0, ymm2 vminps ymm4, ymm0, ymm3 vmaxps ymm7, ymm4, ymm5 vmovaps ymm0, ymm6 vmovaps [rsi], ymm7 add rsi, 32 add rbx, 8 cmp rbx, rcx jl loop </pre>	<pre> xor rbx, rbx mov rcx, len mov rdi, inPtr mov rsi, outPtr vcvtph2ps ymm0, [rdi] loop: add rdi, 16 vcvtph2ps ymm6, [rdi] vperm2f128 ymm1, ymm0, ymm6, 0x21 vshufps ymm3, ymm0, ymm1, 0x4E vshufps ymm2, ymm0, ymm3, 0x99 vminps ymm5, ymm0, ymm2 vmaxps ymm0, ymm0, ymm2 vminps ymm4, ymm0, ymm3 vmaxps ymm7, ymm4, ymm5 vmovaps ymm0, ymm6 vcvtps2ph [rsi], ymm7, roundingCtrl add rsi, 16 add rbx, 8 cmp rbx, rcx jl loop </pre>

When the locality of the working set resides in memory, using half-precision format with processors based on Ivy Bridge microarchitecture is about 30% faster than single-precision format, despite the conversion overhead. When the locality resides in L3, using half-precision format is still ~15% faster. When the locality resides in L1, using single-precision format is faster because the cache bandwidth of the L1 data cache is much higher than the rest of the cache/memory hierarchy and the overhead of the conversion becomes a performance consideration.

15.15 FUSED MULTIPLY-ADD (FMA) INSTRUCTIONS GUIDELINES

FMA instructions perform vectored operations of “a * b + c” on IEEE-754-2008 floating-point values, where the multiplication operations “a * b” are performed with infinite precision, the final results of the addition are rounded to produced the desired precision. Details of FMA rounding behavior and special case handling can be found in section 2.3 of Intel® Architecture Instruction Set Extensions Programming Reference.

FMA instruction can speed up and improve the accuracy of many FP calculations. Haswell microarchitecture implements FMA instructions with execution units on port 0 and port 1 and 256-bit data paths. Dot product, matrix multiplication and polynomial evaluations are expected to benefit from the use of FMA, 256-bit data path and the independent executions on two ports. The peak throughput of FMA from each processor core are 16 single-precision and 8 double-precision results each cycle.

Algorithms designed to use FMA instruction should take into consideration that non-FMA sequence of MULPD/PS and ADDPD/PS likely will produce slightly different results compared to using FMA. For numerical computations involving a convergence criteria, the difference in the precision of intermediate results must be factored into the numeric formalism to avoid surprise in completion time due to rounding issues.

User/Source Coding Rule 29. Factor in precision and rounding characteristics of FMA instructions when replacing multiply/add operations executing non-FMA instructions. FMA improves performance when an algorithm is execution-port throughput limited, like DGEMM.

There may be situations where using FMA might not deliver better performance. Consider the vectored operation of “a * b + c * d” and data are ready at the same time:

In the three-instruction sequence of

```
VADDPS ( VMULPS (a,b) , VMULPS (c,b) );
```

VMULPS can be dispatched in the same cycle and execute in parallel, leaving the latency of VADDPS (3 cycle) exposed. With unrolling the exposure of VADDPS latency may be further amortized.

When using the two-instruction sequence of

```
VFMADD213PS ( c, d, VMULPS (a,b) );
```

The latency of FMA (5 cycle) is exposed for producing each vector result.

User/Source Coding Rule 30. Factor in result-dependency, latency of FP add vs. FMA instructions when replacing FP add operations with FMA instructions.

15.15.1 Optimizing Throughput with FMA and Floating-Point Add/MUL

In the Skylake microarchitecture, there are two pipes of executions supporting FMA, vector FP Multiply, and FP ADD instructions. All three categories of instructions have a latency of 4 cycles and can dispatch to either port 0 or port 1 to execute every cycle.

The arrangement of identical latency and number of pipes allows software to increase the performance of situations where floating-point calculations are limited by the floating-point add operations that follow FP multiplies. Consider a situation of vector operation $A_n = C_1 + C_2 * A_{n-1}$:

Example 15-35. FP Mul/FP Add Versus FMA

FP Mul/FP Add Sequence	FMA Sequence
<pre>mov eax, NumOfIterations mov rbx, pA mov rcx, pC1 mov rdx, pC2 vmovups ymm0, ymmword ptr [rbx] // A vmovups ymm1, ymmword ptr [rcx] // C1 vmovups ymm2, ymmword ptr [rdx] // C2 loop: vmulps ymm4, ymm0, ymm2 // A * C2 vaddps ymm0, ymm1, ymm4 dec eax jnz loop vmovups ymmword ptr [rbx], ymm0 // store A</pre>	<pre>mov eax, NumOfIterations mov rbx, pA mov rcx, pC1 mov rdx, pC2 vmovups ymm0, ymmword ptr [rbx] // A vmovups ymm1, ymmword ptr [rcx] // C1 vmovups ymm2, ymmword ptr [rdx] // C2 loop: vfmadd132ps ymm0, ymm1, ymm2 // C1 + A * C2 dec eax jnz loop vmovups ymmword ptr [rbx], ymm0 // store A</pre>

Example 15-35. FP Mul/FP Add Versus FMA

FP Mul/FP Add Sequence	FMA Sequence
Cost per iteration: ~ fp add latency + fp add latency	Cost per iteration: ~ fma latency

The overall throughput of the code sequence on the LHS is limited by the combined latency of the FP MUL and FP ADD instructions of specific microarchitecture. The overall throughput of the code sequence on the RHS is limited by the throughput of the FMA instruction of the corresponding microarchitecture.

A common situation where the latency of the FP ADD operation dominates performance is the following C code:

```
for ( int i = 0; i < arrLength; i ++ ) result += arrToSum[i];
```

Example 15-35 shows two implementations with and without unrolling.

Example 15-36. Unrolling to Hide Dependent FP Add Latency

No Unroll	Unroll 8 times
<pre> mov eax, arrLength mov rbx, arrToSum vmovups ymm0, ymmword ptr [rbx] sub eax, 8 loop: add rbx, 32 vaddps ymm0, ymm0, ymmword ptr [rbx] sub eax, 8 jnz loop vextractf128 xmm1, ymm0, 1 vaddps xmm0, xmm0, xmm1 vpermilps xmm1, xmm0, 0xe vaddps xmm0, xmm0, xmm1 vpermilps xmm1, xmm0, 0x1 vaddss xmm0, xmm0, xmm1 </pre>	<pre> mov eax, arrLength mov rbx, arrToSum vmovups ymm0, ymmword ptr [rbx] vmovups ymm1, ymmword ptr 32[rbx] vmovups ymm2, ymmword ptr 64[rbx] vmovups ymm3, ymmword ptr 96[rbx] vmovups ymm4, ymmword ptr 128[rbx] vmovups ymm5, ymmword ptr 160[rbx] vmovups ymm6, ymmword ptr 192[rbx] vmovups ymm7, ymmword ptr 224[rbx] sub eax, 64 loop: add rbx, 256 vaddps ymm0, ymm0, ymmword ptr [rbx] vaddps ymm1, ymm1, ymmword ptr 32[rbx] vaddps ymm2, ymm2, ymmword ptr 64[rbx] vaddps ymm3, ymm3, ymmword ptr 96[rbx] vaddps ymm4, ymm4, ymmword ptr 128[rbx] vaddps ymm5, ymm5, ymmword ptr 160[rbx] vaddps ymm6, ymm6, ymmword ptr 192[rbx] vaddps ymm7, ymm7, ymmword ptr 224[rbx] sub eax, 64 jnz loop vaddps ymm0, ymm0, ymm1 vaddps ymm2, ymm2, ymm3 vaddps ymm4, ymm4, ymm5 vaddps ymm6, ymm6, ymm7 vaddps ymm0, ymm0, ymm2 vaddps ymm4, ymm4, ymm6 vaddps ymm0, ymm0, ymm4 </pre>

Example 15-36. Unrolling to Hide Dependent FP Add Latency (Contd.)

No Unroll	Unroll 8 times
movss result, xmm0	vextractf128 xmm1, ymm0, 1 vaddps xmm0, xmm0, xmm1 vpermilps xmm1, xmm0, 0xe vaddps xmm0, xmm0, xmm1 vpermilps xmm1, xmm0, 0x1 vaddss xmm0, xmm0, xmm1 movss result, xmm0

Without unrolling (LHS of Example 15-35), the cost of summing every 8 array elements is about proportional to the latency of the FP ADD instruction, assuming the working set fit in L1. To use unrolling effectively, the number of unrolled operations should be at least “latency of the critical operation” * “number of pipes”. The performance gain of optimized unrolling versus no unrolling, for a given microarchitecture, can approach “number of pipes” * “Latency of FP ADD”.

User/Source Coding Rule 31. Consider using unrolling technique for loops containing back-to-back dependent FMA, FP Add or Vector MUL operations, The unrolling factor can be chosen by considering the latency of the critical instruction of the dependency chain and the number of pipes available to execute that instruction.

15.15.2 Optimizing Throughput with Vector Shifts

In the Skylake microarchitecture, many common vector shift instructions can dispatch into either port 0 or port 1, compared to only one port in prior generations, see Table 2-12 and Table E-2.

A common situation where the latency of the FP ADD operation dominates performance is the following C code, where a, b, and c are integer arrays:

```
for ( int i = 0; i < len; i ++ ) c[i] += 4* a[i] + b[i]/2;
```

Example 15-35 shows two implementations with and without unrolling.

Example 15-37. FP Mul/FP Add Versus FMA

FP Mul/FP Add Sequence	FMA Sequence
<pre>mov eax, NumOfIterations mov rbx, pA mov rcx, pC1 mov rdx, pC2 vmovups ymm0, ymmword ptr [rbx] // A vmovups ymm1, ymmword ptr [rcx] // C1 vmovups ymm2, ymmword ptr [rdx] // C2 loop: vmulps ymm4, ymm0, ymm2 // A * C2 vaddps ymm0, ymm1, ymm4 dec eax jnz loop vmovups ymmword ptr [rbx], ymm0 // store An</pre>	<pre>mov eax, NumOfIterations mov rbx, pA mov rcx, pC1 mov rdx, pC2 vmovups ymm0, ymmword ptr [rbx] // A vmovups ymm1, ymmword ptr [rcx] // C1 vmovups ymm2, ymmword ptr [rdx] // C2 loop: vfmadd132ps ymm0, ymm1, ymm2 // C1 + A * C2 dec eax jnz loop vmovups ymmword ptr [rbx], ymm0 // store An</pre>
Cost per iteration: ~ fp add latency + fp add latency	Cost per iteration: ~ fma latency

15.16 AVX2 OPTIMIZATION GUIDELINES

AVX2 instructions promotes the great majority of 128-bit SIMD integer instructions to operate on 256-bit YMM registers. AVX2 also adds a rich mix of broadcast/permute/variable-shift instructions to accelerate numerical computations. The 256-bit AVX2 instructions are supported by Haswell microarchitecture, which implements 256-bit data path with low latency and high throughput.

Consider an intra-coding 4x4 block image transformation¹ shown in Figure 15-3.

A 128-bit SIMD implementation can perform this transformation by the following technique:

- Convert 8-bit pixels into 16-bit word elements and fetch two 4x4 image block as 4 row vectors.
- The matrix operation $1/128 * (B \times R)$ can be evaluated with row vectors of the image block and column vectors of the right-hand-side coefficient matrix using a sequence of SIMD instructions of PMADDWD, packed shift and blend instructions.
- The two 4x4 word-granular, intermediate result can be re-arranged into column vectors.
- The left-hand-side coefficient matrix in row vectors and the column vectors of the intermediate block can be calculated (using PMADDWD, shift, blend) and written out.

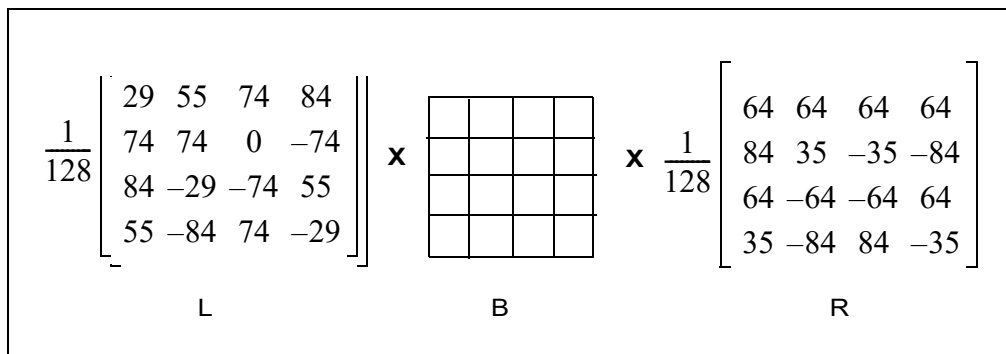

Figure 15-3. 4x4 Image Block Transformation

The same technique can be implemented using AVX2 instructions in a straightforward manner. The AVX2 sequence is illustrated in Example 15-38 and Example 15-39.

Example 15-38. Macros for Separable KLT Intra-block Transformation Using AVX2

```
// b0: input row vector from 4 consecutive 4x4 image block of word pixels
// rmc0-3: columnar vector coefficient of the RHS matrix, repeated 4X for 256-bit
// min32km1: saturation constant vector to cap intermediate pixel to less than or equal to 32767
// w0: output row vector of garbled intermediate matrix, elements within each block are garbled
// e.g Low 128-bit of row 0 in descending order: y07, y05, y06, y04, y03, y01, y02, y00

#define __MyM_KIP_PxRMC_ROW_4x4Wx4(b0, w0, rmc0_256,
rmc1_256, rmc2_256, rmc3_256, min32km1)\
```

1. C. Yeo, Y. H. Tan, Z. Li and S. Rahardja, “Mode-Dependent Fast Separable KLT for Block-based Intra Coding,” JCTVC-B024, Geneva, Switzerland, Jul 2010

Example 15-38. Macros for Separable KLT Intra-block Transformation Using AVX2 (Contd.)

```

{__m256i tt0, tt1, tt2, tt3, tttmp;\
  tt0 = _mm256_madd_epi16(b0, (rmc0_256));\
  tt1 = _mm256_madd_epi16(b0, rmc1_256);\
  tt1 = _mm256_hadd_epi32(tt0, tt1);\
  tttmp = _mm256_srai_epi32( tt1, 31);\
  tttmp = _mm256_srli_epi32( tttmp, 25);\
  tt1 = _mm256_add_epi32( tt1, tttmp);\
  tt1 = _mm256_min_epi32(_mm256_srai_epi32( tt1, 7), min32km1);\
  tt1 = _mm256_shuffle_epi32(tt1, 0xd8); \
  tt2 = _mm256_madd_epi16(b0, rmc2_256);\
  tt3 = _mm256_madd_epi16(b0, rmc3_256);\
  tt3 = _mm256_hadd_epi32(tt2, tt3);\
  tttmp = _mm256_srai_epi32( tt3, 31);\
  tttmp = _mm256_srli_epi32( tttmp, 25);\
  tt3 = _mm256_add_epi32( tt3, tttmp);\
  tt3 = _mm256_min_epi32( _mm256_srai_epi32(tt3, 7), min32km1);\
  tt3 = _mm256_shuffle_epi32(tt3, 0xd8);\
  w0 = _mm256_blend_epi16(tt1, _mm256_slli_si256( tt3, 2), 0xaa);\
}
// t0-t3: 256-bit input vectors of un-garbled intermediate matrix 1/128 * (B x R)
// lmr_256: 256-bit vector of one row of LHS coefficient, repeated 4X
// min32km1: saturation constant vector to cap final pixel to less than or equal to 32767
// w0; Output row vector of final result in un-garbled order
#define __MyM_KIP_LMRxP_ROW_4x4Wx4(w0, t0, t1, t2, t3, lmr_256, min32km1)\
  {__m256i tb0, tb1, tb2, tb3, tbtmp;\
  tb0 = _mm256_madd_epi16( lmr_256, t0);\
  tb1 = _mm256_madd_epi16( lmr_256, t1);\
  tb1 = _mm256_hadd_epi32(tb0, tb1);\
  tbtmp = _mm256_srai_epi32( tb1, 31);\
  tbtmp = _mm256_srli_epi32( tbtmp, 25);\
  tb1 = _mm256_add_epi32( tb1, tbtmp);\
  tb1 = _mm256_min_epi32( _mm256_srai_epi32( tb1, 7), min32km1);\
  tb1 = _mm256_shuffle_epi32(tb1, 0xd8);\
  tb2 = _mm256_madd_epi16( lmr_256, t2);\
  tb3 = _mm256_madd_epi16( lmr_256, t3);\
  tb3 = _mm256_hadd_epi32(tb2, tb3);\
  tbtmp = _mm256_srai_epi32( tb3, 31);\
  tbtmp = _mm256_srli_epi32( tbtmp, 25);\
  tb3 = _mm256_add_epi32( tb3, tbtmp);\
  tb3 = _mm256_min_epi32( _mm256_srai_epi32( tb3, 7), min32km1);\
  tb3 = _mm256_shuffle_epi32(tb3, 0xd8); \
  tb3 = _mm256_slli_si256( tb3, 2);\
  tb3 = _mm256_blend_epi16(tb1, tb3, 0xaa);\
}

```

Example 15-38. Macros for Separable KLT Intra-block Transformation Using AVX2 (Contd.)

```

w0 = _mm256_shuffle_epi8(tb3, _mm256_setr_epi32( 0x5040100, 0x7060302, 0xd0c0908, 0xf0e0b0a,
0x5040100, 0x7060302, 0xd0c0908, 0xf0e0b0a));\
}

```

In Example 15-39, matrix multiplication of $1/128 * (B \times R)$ is evaluated first in a 4-wide manner by fetching from 4 consecutive 4x4 image block of word pixels. The first macro shown in Example 15-38 produces an output vector where each intermediate row result is in an garbled sequence between the two middle elements of each 4x4 block. In Example 15-39, undoing the garbled elements and transposing the intermediate row vector into column vectors are implemented using blend primitives instead of shuffle/unpack primitives.

In Haswell microarchitecture, shuffle/pack/unpack primitives rely on the shuffle execution unit dispatched to port 5. In some situations of heavy SIMD sequences, port 5 pressure may become a determining factor in performance.

If 128-bit SIMD code faces port 5 pressure when running on Haswell microarchitecture, porting 128-bit code to use 256-bit AVX2 can improve performance and alleviate port 5 pressure.

Example 15-39. Separable KLT Intra-block Transformation Using AVX2

```

short __declspec(align(16))cst_rmc0[8] = {64, 84, 64, 35, 64, 84, 64, 35};
short __declspec(align(16))cst_rmc1[8] = {64, 35, -64, -84, 64, 35, -64, -84};
short __declspec(align(16))cst_rmc2[8] = {64, -35, -64, 84, 64, -35, -64, 84};
short __declspec(align(16))cst_rmc3[8] = {64, -84, 64, -35, 64, -84, 64, -35};
short __declspec(align(16))cst_lmr0[8] = {29, 55, 74, 84, 29, 55, 74, 84};
short __declspec(align(16))cst_lmr1[8] = {74, 74, 0, -74, 74, 74, 0, -74};
short __declspec(align(16))cst_lmr2[8] = {84, -29, -74, 55, 84, -29, -74, 55};
short __declspec(align(16))cst_lmr3[8] = {55, -84, 74, -29, 55, -84, 74, -29};

void Klt_256_d(short * Input, short * Output, int iWidth, int iHeight)
{int iX, iY;
__m256i rmc0 = _mm256_broadcastsi128_si256( _mm_loadu_si128((__m128i *) &cst_rmc0[0]));
__m256i rmc1 = _mm256_broadcastsi128_si256( _mm_loadu_si128((__m128i *)&cst_rmc1[0]));
__m256i rmc2 = _mm256_broadcastsi128_si256( _mm_loadu_si128((__m128i *)&cst_rmc2[0]));
__m256i rmc3 = _mm256_broadcastsi128_si256( _mm_loadu_si128((__m128i *)&cst_rmc3[0]));
__m256i lmr0 = _mm256_broadcastsi128_si256( _mm_loadu_si128((__m128i *)&cst_lmr0[0]));
__m256i lmr1 = _mm256_broadcastsi128_si256( _mm_loadu_si128((__m128i *)&cst_lmr1[0]));
__m256i lmr2 = _mm256_broadcastsi128_si256( _mm_loadu_si128((__m128i *)&cst_lmr2[0]));
__m256i lmr3 = _mm256_broadcastsi128_si256( _mm_loadu_si128((__m128i *)&cst_lmr3[0]));
__m256i min32km1 = _mm256_broadcast_epi32(_mm_cvtsi32_si128( _mm_setr_epi32( 0x7fff7fff, 0x7fff7fff,
0x7fff7fff, 0x7fff7fff)));
__m256i b0, b1, b2, b3, t0, t1, t2, t3;
__m256i w0, w1, w2, w3;
short* pImage = Input;
short* pOutImage = Output;
int hgt = iHeight, wid= iWidth;

```

(continue)

Example 15-39. Separable KLT Intra-block Transformation Using AVX2 (Contd.)

```

// We implement 1/128 * (Mat_L x (1/128 * (Mat_B x Mat_R))) from the inner most parenthesis
for( iY = 0; iY < hgt; iY+=4) {
  for( iX = 0; iX < wid; iX+=16) {
    //load row 0 of 4 consecutive 4x4 matrix of word pixels
    b0 = _mm256_loadu_si256( (__m256i *) (plmage + iY*wid+ iX));
    // multiply row 0 with columnar vectors of the RHS matrix coefficients
    __MyM_KIP_PxRMC_ROW_4x4Wx4(b0, w0, rmc0, rmc1, rmc2, rmc3, min32km1);
    // low 128-bit of garbled row 0, from hi->lo: y07, y05, y06, y04, y03, y01, y02, y00
    b1 = _mm256_loadu_si256( (__m256i *) (plmage + (iY+1)*wid+ iX));
    __MyM_KIP_PxRMC_ROW_4x4Wx4(b1, w1, rmc0, rmc1, rmc2, rmc3, min32km1);
    // hi->lo y17, y15, y16, y14, y13, y11, y12, y10
    b2 = _mm256_loadu_si256( (__m256i *) (plmage + (iY+2)*wid+ iX));
    __MyM_KIP_PxRMC_ROW_4x4Wx4(b2, w2, rmc0, rmc1, rmc2, rmc3, min32km1);
    b3 = _mm256_loadu_si256( (__m256i *) (plmage + (iY+3)*wid+ iX));
    __MyM_KIP_PxRMC_ROW_4x4Wx4(b3, w3, rmc0, rmc1, rmc2, rmc3, min32km1);

    // unscramble garbled middle 2 elements of each 4x4 block, then
    // transpose into columnar vectors: t0 has 4 consecutive column 0 or 4 4x4 intermediate
    t0 = _mm256_blend_epi16( w0, _mm256_slli_epi64(w1, 16), 0x22);
    t0 = _mm256_blend_epi16( t0, _mm256_slli_epi64(w2, 32), 0x44);
    t0 = _mm256_blend_epi16( t0, _mm256_slli_epi64(w3, 48), 0x88);
    t1 = _mm256_blend_epi16( _mm256_srli_epi64(w0, 32), _mm256_srli_epi64(w1, 16), 0x22);
    t1 = _mm256_blend_epi16( t1, w2, 0x44);
    t1 = _mm256_blend_epi16( t1, _mm256_slli_epi64(w3, 16), 0x88); // column 1
    t2 = _mm256_blend_epi16( _mm256_srli_epi64(w0, 16), w1, 0x22);
    t2 = _mm256_blend_epi16( t2, _mm256_slli_epi64(w2, 16), 0x44);
    t2 = _mm256_blend_epi16( t2, _mm256_slli_epi64(w3, 32), 0x88); // column 2
    t3 = _mm256_blend_epi16( _mm256_srli_epi64(w0, 48), _mm256_srli_epi64(w1, 32), 0x22);
    t3 = _mm256_blend_epi16( t3, _mm256_srli_epi64(w2, 16), 0x44);
    t3 = _mm256_blend_epi16( t3, w3, 0x88); // column 3

    // multiply row 0 of the LHS coefficient with 4 columnar vectors of intermediate blocks
    // final output row are arranged in normal order
    __MyM_KIP_LMRxP_ROW_4x4Wx4(w0, t0, t1, t2, t3, lmr0, min32km1);
    _mm256_store_si256( (__m256i *) (pOutImage+iY*wid+ iX), w0);

    __MyM_KIP_LMRxP_ROW_4x4Wx4(w1, t0, t1, t2, t3, lmr1, min32km1);
    _mm256_store_si256( (__m256i *) (pOutImage+(iY+1)*wid+ iX), w1);

    __MyM_KIP_LMRxP_ROW_4x4Wx4(w2, t0, t1, t2, t3, lmr2, min32km1);
    _mm256_store_si256( (__m256i *) (pOutImage+(iY+2)*wid+ iX), w2);
  }
}

```

Example 15-39. Separable KLT Intra-block Transformation Using AVX2 (Contd.)

```

    __MyM_KIP_LMRxP_ROW_4x4Wx4(w3, t0, t1, t2, t3, lmr3, min32km1);
    __mm256_store_si256( (__m256i *) (pOutImage+(iY+3)*wid+ iX), w3);
}
}
}

```

Although 128-bit SIMD implementation is not shown here, it can be easily derived.

When running 128-bit SIMD code of this KLT intra-coding transformation on Sandy Bridge microarchitecture, the port 5 pressure are less because there are two shuffle units, and the effective throughput for each 4x4 image block transformation is around 50 cycles. Its speed-up relative to optimized scalar implementation is about 2.5X.

When the 128-bit SIMD code runs on Haswell microarchitecture, micro-ops issued to port 5 account for slightly less than 50% of all micro-ops, compared to about one third on prior microarchitecture, resulting in about 25% performance regression. On the other hand, AVX2 implementation can deliver effective throughput in less than 35 cycle per 4x4 block.

15.16.1 Multi-Buffering and AVX2

There are many compute-intensive algorithms (e.g. hashing, encryption, etc.) which operate on a stream of data buffers. Very often, the data stream may be partitioned and treated as multiple independent buffer streams to leverage SIMD instruction sets.

Detailed treatment of hashing several buffers in parallel can be found at <http://www.scrip.org/journal/PaperInformation.aspx?paperID=23995> and at <http://eprint.iacr.org/2012/476.pdf>.

With AVX2 providing a full compliment of 256-bit SIMD instructions with rich functionality at multiple width granularities for logical and arithmetic operations. Algorithms that had leveraged XMM registers and prior generations of SSE instruction sets can extend those multi-buffering algorithms to use AVX2 on YMM and deliver even higher throughput. Optimized 256-bit AVX2 implementation may deliver up to 1.9X throughput when compared to 128-bit versions.

The image block transformation example discussed in Section 15.16 can be construed also as a multi-buffering implementation of 4x4 blocks. When the performance baseline is switched from a two-shuffle-port microarchitecture (Sandy Bridge) to single-shuffle-port microarchitecture, the 256-bit wide AVX2 provides a speed up of 1.9X relative to 128-bit SIMD implementation.

Greater details on multi-buffering can be found in the white paper at: <http://www.intel.com/content/dam/www/public/us/en/documents/white-papers/communications-ia-multi-buffer-paper.pdf>.

15.16.2 Modular Multiplication and AVX2

Modular multiplication of very large integers are often used to implement efficient modular exponentiation operations which are critical in public key cryptography, such as RSA 2048. Library implementation of modular multiplication is often done with MUL/ADC chain sequences. Typically, a MUL instruction can produce a 128-bit intermediate integer output, and add-carry chains must be used at 64-bit intermediate data granularity.

In AVX2, VPMULUDQ/VPADDQ/VPSRLQ/VPSLLQ/VPBROADCASTQ/VPERMQ allow vectorized approach to implement efficient modular multiplication/exponentiation for key lengths corresponding to RSA1024 and RSA2048. For details of modular exponentiation/multiplication and AVX2 implementation in OpenSSL, see http://rd.springer.com/chapter/10.1007%2F978-3-642-31662-3_9?LI=true.

The basic heuristic starts with reformulating the large integer input operands in 512/1024 bit exponentiation in redundant representations. For example, a 1024-bit integer can be represented using base 2^{29} and 36 “**digits**”, where each “**digit**” is less than 2^{29} . A digit in such redundant representation can be placed in a dword slot of a vector register. Such redundant representation of large integer simplifies the requirement to perform carry-add chains across the hardware granularity of the intermediate results of unsigned integer multiplications.

Each VPMULUDQ in AVX2 using the **digits** from a redundant representation can produce 4 separate 64-bit intermediate result with sufficient headroom (e.g. 5 most significant bits are 0 excluding sign bit). Then, VPADDQ is sufficient to implement add-carry chain requirement without needing SIMD versions of equivalent of ADC-like instructions. More details are available in the reference cited in paragraph above, including the cost factor of conversion to redundant representation and effective speedup accounting for parallel output bandwidth of VPMULUDQ/VPADDQ chain.

15.16.3 Data Movement Considerations

Haswell microarchitecture can support up to two 256-bit loads and one 256-bit store micro-ops dispatched each cycle. Most existing binaries with heavy data-movement operation can benefit from this enhancement and the higher bandwidths of the L1 data cache and L2 without re-compilation, if the binary is already optimized for the prior generation microarchitecture. For example, 256-bit SAXPY computation was limited by the number of load/store ports available in the previous microarchitecture generation; it will benefit immediately on Haswell microarchitecture.

In some situations, there may be some intricate interactions between microarchitectural restrictions on the instruction set that is worth some discussion. We consider two commonly used library functions `memcpy()` and `memset()` and the optimal choice to implement them on the new microarchitecture.

With `memcpy()` on Haswell microarchitecture, using REP MOVSB to implement `memcpy` operation for large copy length can take advantage the 256-bit store data path and deliver throughput of more than 20 bytes per cycle. For copy length that are smaller than a few hundred bytes, REP MOVSB approach is slower than using 128-bit SIMD technique described in Section 15.16.3.1.

With `memcpy()` on Ice Lake microarchitecture, using in-lined REP MOVSB to implement `memcpy` is as fast as a 256-bit AVX implementation for copy lengths that are variable and unknown at compile time. For lengths that are known at compile time, REP MOVSB is almost as good as 256-bit AVX for short strings up to 128 bytes (9 cycles vs 3-7 cycles), and better for strings of 2K bytes and longer. For these cases we recommend using inline REP MOVSB. That said, software should still branch away for zero byte copies.

15.16.3.1 SIMD Heuristics to implement Memcpy()

We start with a discussion of the general heuristic to attempt implementing `memcpy()` with 128-bit SIMD instructions, which revolves around three numeric factors (destination address alignment, source address alignment, bytes to copy) relative to the width of register width of the desired instruction set. The data movement work of `memcpy` can be separated into the following phases:

- An initial unaligned copy of 16 bytes, allows looping destination address pointer to become 16-byte aligned. Thus subsequent store operations can use as many 16-byte aligned stores.
- The remaining bytes-left-to-copy are decomposed into (a) multiples of unrolled 16-byte copy operations, plus (b) residual count that may include some copy operations of less than 16 bytes. For example, to unroll eight time to amortize loop iteration overhead, the residual count must handle individual cases from 1 to $8 \times 16 - 1 = 127$.
- Inside an 8X16 unrolled main loop, each 16 byte copy operation may need to deal with source pointer address is not aligned to 16-byte boundary and store 16 fresh data to 16B-aligned destination address. When the iterating source pointer is not 16B-aligned, the most efficient technique is a three instruction sequence of:
 - Fetch an 16-byte chunk from an 16-byte-aligned adjusted pointer address and use a portion of this chunk with complementary portion from previous 16-byte-aligned fetch.
 - Use PALIGNR to stitch a portion of the current chunk with the previous chunk.

- Stored stitched 16-byte fresh data to aligned destination address, and repeat this 3 instruction sequence.

This 3-instruction technique allows the fetch:store instruction ratio for each 16-byte copy operation to remain at 1:1.

While the above technique (specifically, the main loop dealing with copying thousands of bytes of data) can achieve throughput of approximately 10 bytes per cycle on Sandy Bridge and Ivy Bridge microarchitectures with 128-bit data path for store operations, an attempt to extend this technique to use wider data path will run into the following restrictions:

- To use 256-bit VPALIGNR with its 2X128-bit lane microarchitecture, stitching of two partial chunks of the current 256-bit 32-byte-aligned fetch requires another 256-bit fetch from an address 16-byte offset from the current 32-byte-aligned 256-bit fetch.
 - The fetch:store ratio for each 32-byte copy operation becomes 2:1.
 - The 32-byte-unaligned fetch (although aligned to 16-byte boundary) will experience a cache-line split penalty, once every 64-bytes of copy operation.

The net of this attempt to use 256-bit ISA to take advantage of the 256-bit store data-path microarchitecture was offset by the 4-instruction sequence and cacheline split penalty.

15.16.3.2 Memcpy() Implementation Using Enhanced REP MOVSB

It is interesting to compare the alternate approach of using enhanced REP MOVSB to implement memcpy(). In Haswell and Ivy Bridge microarchitectures, REP MOVSB is an optimized, hardware provided, micro-op flow.

On Ivy Bridge microarchitecture, a REP MOVSB implementation of memcpy can achieve throughput at slightly better than the 128-bit SIMD implementation when copying thousands of bytes. However, if the size of copy operation is less than a few hundred bytes, the REP MOVSB approach is less efficient than the explicit residual copy technique described in phase 2 of Section 15.16.3.1. This is because handling 1-127 residual copy length (via jump table or switch/case, and is done before the main loop) plus one or two 8x16B iterations incurs less branching overhead than the hardware provided micro-op flows. For the grueling implementation details of 128-bit SIMD implementation of memcpy(), one can look up from the archived sources of open source library such as Glibc.

On Haswell microarchitecture, using REP MOVSB to implement memcpy operation for large copy length can take advantage the 256-bit store data path and deliver throughput of more than 20 bytes per cycle. For copy length that are smaller than a few hundred bytes, REP MOVSB approach is still slower than treating the copy length as the residual phase of Section 15.16.3.1.

15.16.3.3 Memset() Implementation Considerations

The interface of Memset() has one address pointer as destination, which simplifies the complexity of managing address alignment scenarios to use 256-bit aligned store instruction. After an initial unaligned store, and adjusting the destination pointer to be 32-byte aligned, the residual phase follows the same consideration as described in Section 15.16.3.1, which may employ a large jump table to handle each residual value scenario with minimal branching, depending on the amount of unrolled 32B-aligned stores. The main loop is a simple YMM register to 32-byte-aligned store operation, which can deliver close to 30 bytes per cycle for lengths more than a thousand byte. The limiting factor here is due to each 256-bit VMOVDQA store consists of a store_address and a store_data micro-op flow. Only port 4 is available to dispatch the store_data micro-op each cycle.

Using REP STOSB to implement memset() has the code size advantage versus a SIMD implementation, like REP MOVSB for memcpy(). On Haswell microarchitecture, a memset() routine implemented using REP STOSB will also benefit from the 256-bit data path and increased L1 data cache bandwidth to deliver up to 32 bytes per cycle for large count values.

Comparing the performance of memset() implementations using REP STOSB vs. 256-bit AVX2 requires one to consider the pattern of invocation of memset(). The invocation pattern can lead to the necessity of using different performance measurement techniques. There may be side effects affecting the outcome of each measurement technique.

The most common measurement technique that is often used with a simple routine like `memset()` is to execute `memset()` inside a loop with a large iteration count, and wrap the invocation of RDTSC before and after the loop.

A slight variation of this measurement technique can apply to measuring `memset()` invocation patterns of multiple back-to-back calls to `memset()` with different count values with no other intervening instruction streams executed between calls to `memset()`.

In both of the above `memset()` invocation scenarios, branch prediction can play a significant role in affecting the measured total cycles for executing the loop. Thus, measuring AVX2-implemented `memset()` under a large loop to minimize RDTSC overhead can produce a skewed result with the branch predictor being trained by the large loop iteration count.

In more realistic software stacks, the invocation patterns of `memset()` will likely have the characteristics that:

- There are intervening instruction streams being executed between invocations of `memset()`, the state of branch predictor prior to `memset()` invocation is not pre-trained for the branching sequence inside a `memset()` implementation.
- `Memset()` count values are likely to be uncorrected.

The proper measurement technique to compare `memset()` performance for more realistic `memset()` invocation scenarios will require a per-invocation technique that wraps two RDTSC around each invocation of `memset()`.

With the per-invocation RDTSC measurement technique, the overhead of RDTSC can be pre-calibrated and post-validated outside of a measurement loop. The per-invocation technique may also consider cache warming effect by using a loop to wrap around the per-invocation measurements.

When the relevant skew factors of measurement techniques are taken into effect, the performance of `memset()` using REP STOSB, for count values smaller than a few hundred bytes, is generally faster than the AVX2 version for the common `memset()` invocation scenarios. Only in the extreme scenarios of hundreds of unrolled `memset()` calls, all using count values less than a few hundred bytes and with no intervening instruction stream between each pair of `memset()` can the AVX2 version of `memset()` take advantage of the training effect of the branch predictor.

15.16.3.4 Hoisting Memcpy/Memset Ahead of Consuming Code

There may be situations where the data furnished by a call to `memcpy()/memset()` and subsequent instructions consuming the data can be re-arranged:

```
memcpy ( pBuf, pSrc, Cnt); // make a copy of some data with knowledge of Cnt
.... // subsequent instruction sequences are not consuming pBuf immediately
result = compute( pBuf); // memcpy result consumed here
```

When the count is known to be at least a thousand byte or more, using enhanced REP MOVSB/STOSB can provide another advantage to amortize the cost of the non-consuming code. The heuristic can be understood using a value of `Cnt = 4096` and `memset()` as example:

- A 256-bit SIMD implementation of `memset()` will need to issue/execute retire 128 instances of 32-byte store operation with `VMOVDQA`, before the non-consuming instruction sequences can make their way to retirement.
- An instance of enhanced REP STOSB with `ECX= 4096` is decoded as a long micro-op flow provided by hardware, but retires as one instruction. There are many store_data operation that must complete before the result of `memset()` can be consumed. Because the completion of store data operation is de-coupled from program-order retirement, a substantial part of the non-consuming code stream can process through the issue/execute and retirement, essentially cost-free if the non-consuming sequence does not compete for store buffer resources.

Software that use enhanced REP MOVSB/STOSB must check its availability by verifying `CPUID.(EAX=07H, ECX=0):EBX.[bit 9]` reports 1.

15.16.3.5 256-bit Fetch versus Two 128-bit Fetches

On Sandy Bridge and Ivy Bridge microarchitectures, using two 16-byte aligned loads are preferred due to the 128-bit data path limitation in the memory pipeline of the microarchitecture.

To take advantage of Haswell microarchitecture's 256-bit data path microarchitecture, the use of 256-bit loads must consider the alignment implications. Instruction that fetched 256-bit data from memory should pay attention to be 32-byte aligned. If a 32-byte unaligned fetch would span across cache line boundary, it is still preferable to fetch data from two 16-byte aligned address instead.

15.16.3.6 Mixing MULX and AVX2 Instructions

Combining MULX and AVX2 instruction can further improve the performance of some common computation task, e.g. numeric conversion 64-bit integer to ascii format can benefit from the flexibility of MULX register allocation, wider YMM register, and variable packed shift primitive VPSRLVD for parallel moduli/remainder calculations.

Example 15-40 shows a macro sequence of AVX2 instruction to calculate one or two finite range unsigned short integer(s) into respective decimal digits, featuring VPSRLVD in conjunction with Montgomery reduction technique.

Example 15-40. Macros for Parallel Moduli/Remainder Calculation

```
static short quoTenThsn_mulplr_d[16] =
{ 0x199a, 0, 0x28f6, 0, 0x20c5, 0, 0x1a37, 0, 0x199a, 0, 0x28f6, 0, 0x20c5, 0, 0x1a37, 0};
static short mten_mulplr_d[16] = { -10, 1, -10, 1, -10, 1, -10, 1, -10, 1, -10, 1, -10, 1, -10, 1};

// macro to convert input t5 (a __m256i type) containing quotient (dword 4) and remainder
// (dword 0) into single-digit integer (between 0-9) in output y3 ( a__m256i);
//both dword element "t5" is assume to be less than 10^4, the rest of dword must be 0;
//the output is 8 single-digit integer, located in the low byte of each dword, MS digit in dword 0
#define __ParMod10to4AVX2dw4_0( y3, t5 ) \
{ __m256i x0, x2; \
  x0 = _mm256_shuffle_epi32( t5, 0); \
  x2 = _mm256_mulhi_epu16(x0, _mm256_loadu_si256( (__m256i *) quoTenThsn_mulplr_d));\
  x2 = _mm256_srlv_epi32( x2, _mm256_setr_epi32(0x0, 0x4, 0x7, 0xa, 0x0, 0x4, 0x7, 0xa) ); \
  (y3) = _mm256_or_si256(_mm256_slli_si256(x2, 6), _mm256_slli_si256(t5, 2) ); \
  (y3) = _mm256_or_si256(x2, y3);\
  (y3) = _mm256_madd_epi16(y3, _mm256_loadu_si256( (__m256i *) mten_mulplr_d) );\
}

// parallel conversion of dword integer (< 10^4) to 4 single digit integer in __m128i
#define __ParMod10to4AVX2dw( x3, dw32 ) \
{ __m128i x0, x2; \
  x0 = _mm_broadcastd_epi32( _mm_cvtsi32_si128( dw32)); \
  x2 = _mm_mulhi_epu16(x0, _mm_loadu_si128( (__m128i *) quoTenThsn_mulplr_d));\
  x2 = _mm_srlv_epi32( x2, _mm_setr_epi32(0x0, 0x4, 0x7, 0xa) ); \
  (x3) = _mm_or_si128(_mm_slli_si128(x2, 6), _mm_slli_si128(_mm_cvtsi32_si128( dw32), 2) ); \
  (x3) = _mm_or_si128(x2, (x3));\
  (x3) = _mm_madd_epi16((x3), _mm_loadu_si128( (__m128i *) mten_mulplr_d) );\
}
```

Example 15-41 shows a helper utility and overall steps to reduce a 64-bit signed integer into a 63-bit unsigned range with reduced-range integer quotient/remainder pairs using MULX. Note that this example relies on Example 15-40 and Example 15-42.

Example 15-41. Signed 64-bit Integer Conversion Utility

```
#define QWCG10to 80xabcc77118461cefdull

static int pr_cg_10to4[8] = { 0x68db8db, 0, 0, 0, 0x68db8db, 0, 0, 0};
static int pr_1_m10to4[8] = { -10000, 0, 0, 0, 1, 0, 0, 0};
      (continue)

char * i64toa_avx2i( __int64 xx, char * p)
{int cnt;
  _mm256_zeroupper();
  if( xx < 0) cnt = avx2i_q2a_u63b(-xx, p);
  else cnt = avx2i_q2a_u63b(xx, p);
  p[cnt] = 0;
  return p;
}

// Convert unsigned short (< 10^4) to ascii
__inline int ubsAvx2_Lt10k_2s_i2(int x_Lt10k, char *ps)
{int tmp;
 __m128i x0, m0, x2, x3, x4;
 if( x_Lt10k < 10) { *ps = '0' + x_Lt10k; return 1; }
 x0 = _mm_broadcastd_epi32( _mm_cvtsi32_si128( x_Lt10k));
 // calculate quotients of divisors 10, 100, 1000, 10000
 m0 = _mm_loadu_si128( (__m128i *) quoTenThsn_mulplr_d);
 x2 = _mm_mulhi_epu16(x0, m0);
 // u16/10, u16/100, u16/1000, u16/10000
 x2 = _mm_srlv_epi32( x2, _mm_setr_epi32(0x0, 0x4, 0x7, 0xa) );
 // 0, u16, 0, u16/10, 0, u16/100, 0, u16/1000
 x3 = _mm_insert_epi16(_mm_slli_si128(x2, 6), (int) x_Lt10k, 1);
 x4 = _mm_or_si128(x2, x3);
 // produce 4 single digits in low byte of each dword
 x4 = _mm_madd_epi16(x4, _mm_loadu_si128( (__m128i *) mten_mulplr_d) );// add bias for ascii encoding
 x2 = _mm_add_epi32( x4, _mm_set1_epi32( 0x30303030 ) );
 // pack 4 single digit into a dword, start with most significant digit
 x3 = _mm_shuffle_epi8(x2, _mm_setr_epi32(0x0004080c, 0x80808080, 0x80808080, 0x80808080) );
 if( x_Lt10k > 999 ) {*(int *) ps = _mm_cvtsi128_si32( x3); return 4;}
```

Example 15-41. Signed 64-bit Integer Conversion Utility (Contd.)

```

tmp = _mm_cvtsi128_si32( x3);
if (x_Lt10k > 99 ) {
    *((short *) (ps)) = (short ) (tmp >>8);
    ps[2] = (char ) (tmp >>24);
    return 3;
}

*((short *) ps) = (short ) (tmp>>16); return 2;
}

}

```

Example 15-42 shows the steps of numeric conversion of a 63-bit dynamic range into ascii format according to a progressive range reduction technique using a vectorized Montgomery reduction scheme. Note that this example relies on Example 15-40.

Example 15-42. Unsigned 63-bit Integer Conversion Utility

```

unsigned  avx2i_q2a_u63b (unsigned __int64 xx, char *ps)
{ __m128i v0;
  __m256i m0, x1, x3, x4, x5 ;
  unsigned __int64 xxi, xx2, lo64, hi64;
  __int64 w;
  int j, cnt, abv16, tmp, idx, u;
  // conversion of less than 4 digits
  if ( xx < 10000 ) {
      j = uabsAvx2_Lt10k_2s_i2 ( (unsigned ) xx, ps); return j;
  } else if (xx < 100000000 ) { // dynamic range of xx is less than 9 digits
      // conversion of 5-8 digits
      x1 = _mm256_broadcastd_epi32( _mm_cvtsi32_si128((int)xx)); // broadcast to every dword
      // calculate quotient and remainder, each with reduced range (< 10^4)
      x3 = _mm256_mul_epu32(x1, _mm256_loadu_si256( (__m256i *) pr_cg_10to4 ));
      x3 = _mm256_mullo_epi32(_mm256_srli_epi64(x3, 40), _mm256_loadu_si256( (__m256i *)pr_1_m10to4));
      // quotient in dw4, remainder in dw0
      m0 = _mm256_add_epi32( _mm256_inserti128_si256(_mm256_setzero_si256(), _mm_cvtsi32_si128((int)xx), 0),
x3);
      __ParMod10to4AVX2dw4_0( x3, m0); // 8 digit in low byte of each dw
      x3 = _mm256_add_epi32( x3, _mm256_set1_epi32( 0x30303030 ));
      x4 = _mm256_shuffle_epi8(x3, _mm256_setr_epi32(0x0004080c, 0x80808080, 0x80808080, 0x80808080,
0x0004080c, 0x80808080, 0x80808080, 0x80808080) );

      (continue)

```

Example 15-42. Unsigned 63-bit Integer Conversion Utility (Contd.)

```

// pack 8 single-digit integer into first 8 bytes and set rest to zeros
x4 = _mm256_permutevar8x32_epi32( x4, _mm256_setr_epi32(0x4, 0x0, 0x1, 0x1, 0x1, 0x1, 0x1, 0x1) );
tmp = _mm256_movemask_epi8( _mm256_cmpgt_epi8(x4, _mm256_set1_epi32( 0x30303030 )) );
_BitScanForward((unsigned long *) &idx, tmp);
cnt = 8 -idx; // actual number non-zero-leading digits to write to output
} else { // conversion of 9-12 digits
lo64 = _mulx_u64(xx, (unsigned __int64) QWCG10to8, &xx2);
hi64 >>= 26;

xxi = _mulx_u64(hi64, (unsigned __int64)100000000, &xx2);
lo64 = (unsigned __int64)xx - xxi;

if( hi64 < 10000) { // do digit 12-9 first
__ParMod10to4AVX2dw(v0, (int)hi64);
v0 = _mm_add_epi32( v0, _mm_set1_epi32( 0x30303030 ) );
// continue conversion of low 8 digits of a less-than 12-digit value
x5 = _mm256_inserti128_si256(_mm256_setzero_si256(), _mm_cvtsi32_si128((int)lo64), 0);
x1 = _mm256_broadcastd_epi32( _mm_cvtsi32_si128((int)lo64)); // broadcast to every dword
x3 = _mm256_mul_epu32(x1, _mm256_loadu_si256( (__m256i *) pr_cg_10to4 ));
x3 = _mm256_mullo_epi32(_mm256_srli_epi64(x3, 40), _mm256_loadu_si256( (__m256i *)pr_1_m10to4));
m0 = _mm256_add_epi32( x5, x3); // quotient in dw4, remainder in dw0
__ParMod10to4AVX2dw4_0( x3, m0);
x3 = _mm256_add_epi32( x3, _mm256_set1_epi32( 0x30303030 ) );
x4 = _mm256_shuffle_epi8(x3, _mm256_setr_epi32(0x0004080c, 0x80808080, 0x80808080, 0x80808080,
0x0004080c, 0x80808080, 0x80808080, 0x80808080) );
x5 = _mm256_inserti128_si256(_mm256_setzero_si256(), _mm_shuffle_epi8(v0,
_mm_setr_epi32(0x80808080, 0x80808080, 0x0004080c, 0x80808080)), 0);
x4 = _mm256_permutevar8x32_epi32( _mm256_or_si256(x4, x5), _mm256_setr_epi32(0x2, 0x4, 0x0, 0x1,
0x1, 0x1, 0x1, 0x1) );
tmp = _mm256_movemask_epi8( _mm256_cmpgt_epi8(x4, _mm256_set1_epi32( 0x30303030 )) );
_BitScanForward((unsigned long *) &idx, tmp);
cnt = 12 -idx;
} else { // handle greater than 12 digit input value
cnt = 0;
if ( hi64 > 100000000) { // case of input value has more than 16 digits
xxi = _mulx_u64(hi64, (unsigned __int64) QWCG10to8, &xx2);
abv16 = (int)(xx2 >>26);
hi64 -= _mulx_u64((unsigned __int64) abv16, (unsigned __int64) 100000000, &xx2);
__ParMod10to4AVX2dw(v0, abv16);
v0 = _mm_add_epi32( v0, _mm_set1_epi32( 0x30303030 ) );
v0 = _mm_shuffle_epi8(v0, _mm_setr_epi32(0x0004080c, 0x80808080, 0x80808080, 0x80808080) );

```

(continue)

Example 15-42. Unsigned 63-bit Integer Conversion Utility (Contd.)

```

    tmp = _mm_movemask_epi8( _mm_cmpgt_epi8(v0, _mm_set1_epi32( 0x30303030 ) ));
    _BitScanForward((unsigned long *) &idx, tmp);
    cnt = 4 - idx;
}

// conversion of lower 16 digits
x1 = _mm256_broadcastd_epi32( _mm_cvtsi32_si128((int)hi64)); // broadcast to every dword
x3 = _mm256_mul_epu32(x1, _mm256_loadu_si256( (__m256i *) pr_cg_10to4 ));
x3 = _mm256_mullo_epi32(_mm256_srli_epi64(x3, 40), _mm256_loadu_si256( (__m256i *)pr_1_m10to4));
m0 = _mm256_add_epi32(_mm256_inserti128_si256(_mm256_setzero_si256(), _mm_cvtsi32_si128((int)hi64),
0), x3);
__ParMod10to4AVX2dw4_0( x3, m0);
x3 = _mm256_add_epi32( x3, _mm256_set1_epi32( 0x30303030 ) );
x4 = _mm256_shuffle_epi8(x3, _mm256_setr_epi32(0x0004080c, 0x80808080, 0x80808080, 0x80808080,
0x0004080c, 0x80808080, 0x80808080, 0x80808080) );
x1 = _mm256_broadcastd_epi32( _mm_cvtsi32_si128((int)lo64)); // broadcast to every dword
x3 = _mm256_mul_epu32(x1, _mm256_loadu_si256( (__m256i *) pr_cg_10to4 ));
x3 = _mm256_mullo_epi32(_mm256_srli_epi64(x3, 40), _mm256_loadu_si256( (__m256i *)pr_1_m10to4));
m0 = _mm256_add_epi32(_mm256_inserti128_si256(_mm256_setzero_si256(), _mm_cvtsi32_si128((int)lo64),
0), ), x3);
__ParMod10to4AVX2dw4_0( x3, m0);
x3 = _mm256_add_epi32( x3, _mm256_set1_epi32( 0x30303030 ) );
x5 = _mm256_shuffle_epi8(x3, _mm256_setr_epi32(0x80808080, 0x80808080, 0x0004080c, 0x80808080,
0x80808080, 0x80808080, 0x0004080c, 0x80808080) );
x4 = _mm256_permutevar8x32_epi32( _mm256_or_si256(x4, x5), _mm256_setr_epi32(0x4, 0x0, 0x6, 0x2,
0x1, 0x1, 0x1, 0x1) );
cnt += 16;
if (cnt <= 16) {
    tmp = _mm256_movemask_epi8( _mm256_cmpgt_epi8(x4, _mm256_set1_epi32( 0x30303030 ) ));
    _BitScanForward((unsigned long *) &idx, tmp);
    cnt -= idx;
}
}
}

w = _mm_cvtsi128_si64( _mm256_castsi256_si128(x4));
switch(cnt) {
case 5:*ps++ = (char) (w >>24); *(unsigned *) ps = (w >>32);
break;
case 6:(short *)ps = (short) (w >>16); *(unsigned *) (&ps[2]) = (w >>32);
break;
case 7:*ps = (char) (w >>8); *(short *) (&ps[1]) = (short) (w >>16);
*(unsigned *) (&ps[3]) = (w >>32);

        (continue)

```

Example 15-42. Unsigned 63-bit Integer Conversion Utility (Contd.)

```

break;
case 8: *(long long *)ps = w;
break;
case 9: *ps++ = (char) (w >>24); *(long long *) (&ps[0]) = _mm_cvtsi128_si64(
_mm_srli_si128(_mm256_castsi256_si128(x4), 4));
break;

case 10: *(short *)ps = (short) (w >>16);
*(long long *) (&ps[2]) = _mm_cvtsi128_si64(_mm_srli_si128(_mm256_castsi256_si128(x4), 4));
break;
case 11: *ps = (char) (w >>8); *(short *) (&ps[1]) = (short) (w >>16);
*(long long *) (&ps[3]) = _mm_cvtsi128_si64(_mm_srli_si128(_mm256_castsi256_si128(x4), 4));
break;
case 12: *(unsigned *)ps = (unsigned int) w; *(long long *) (&ps[4]) = _mm_cvtsi128_si64(
_mm_srli_si128(_mm256_castsi256_si128(x4), 4));
break;
case 13: *ps++ = (char) (w >>24); *(unsigned *) ps = (w >>32);
*(long long *) (&ps[4]) = _mm_cvtsi128_si64(_mm_srli_si128(_mm256_castsi256_si128(x4), 8));
break;
case 14: *(short *)ps = (short) (w >>16); *(unsigned *) (&ps[2]) = (w >>32);
*(long long *) (&ps[6]) = _mm_cvtsi128_si64(_mm_srli_si128(_mm256_castsi256_si128(x4), 8));
break;
case 15: *ps = (char) (w >>8); *(short *) (&ps[1]) = (short) (w >>16);
*(unsigned *) (&ps[3]) = (w >>32);
*(long long *) (&ps[7]) = _mm_cvtsi128_si64(_mm_srli_si128(_mm256_castsi256_si128(x4), 8));
break;
case 16: _mm_storeu_si128((__m128i *) ps, _mm256_castsi256_si128(x4));
break;

case 17: u = (int) _mm_cvtsi128_si64(v0); *ps++ = (char) (u >>24);
_mm_storeu_si128((__m128i *) &ps[0], _mm256_castsi256_si128(x4));
break;
case 18: u = (int) _mm_cvtsi128_si64(v0); *(short *)ps = (short) (u >>16);
_mm_storeu_si128((__m128i *) &ps[2], _mm256_castsi256_si128(x4));
break;
case 19: u = (int) _mm_cvtsi128_si64(v0); *ps = (char) (u >>8); *(short *) (&ps[1]) = (short) (u >>16);
_mm_storeu_si128((__m128i *) &ps[3], _mm256_castsi256_si128(x4));
break;
case 20: u = (int) _mm_cvtsi128_si64(v0); *(unsigned *)ps = (short) (u);
_mm_storeu_si128((__m128i *) &ps[4], _mm256_castsi256_si128(x4));
break;
}

return cnt;
}

```

The AVX2 version of numeric conversion across the dynamic range of 3/9/17 output digits are approximately 23/57/54 cycles per input, compared to standard library implementation's range of 85/260/560 cycles per input.

The techniques illustrated above can be extended to numeric conversion of other library, such as binary-integer-decimal (BID) encoded IEEE-754-2008 Decimal floating-point format. For BID-128 format, Example 15-42 can be adapted by adding another range-reduction stage using a pre-computed 256-bit constant to perform Montgomery reduction at modulus 10^{16} . The technique to construct the 256-bit constant is covered in Chapter 14, "SSE4.2 and SIMD Programming For Text-Processing/Lexing/Parsing" of *Intel® 64 and IA-32 Architectures Optimization Reference Manual*.

15.16.4 Considerations for Gather Instructions

VGATHER family of instructions fetch multiple data elements specified by a vector index register containing relative offsets from a base address. Processors based on Haswell microarchitecture is the first implementation of the VGATHER instruction and a single instruction results in multiple micro-ops being executed. In the Broadwell microarchitecture, the throughput of the VGATHER family of instructions have improved significantly; see Table D-5.

Depending on data organization and access patterns, it is possible to create equivalent code sequences without using VGATHER instruction that will execute faster and with fewer micro-ops than a single VGATHER instruction (e.g. see Section 15.5.1). Example 15-43 shows some of the situations where use of VGATHER on Haswell microarchitecture is unlikely to provide performance benefit.

Example 15-43. Access Patterns Favoring Non-VGATHER Techniques

Access Patterns	Recommended Instruction Selection
Sequential elements	Regular SIMD loads (MOVAPS/MOVUPS, MOVDQA/MOVDQU)
Fewer than 4 elements	Regular SIMD load + horizontal data-movement to re-arrange slots
Small Strides	Load all nearby elements + shuffle/permute to collected strided elements: <pre>VMOVUPD YMM0, [sequential elements] VPERMQ YMM1, YMM0, 0x08 // the even elements VPERMQ YMM2, YMM0, 0x0d // the odd elements</pre>
Transpositions	Regular SIMD loads + shuffle/permute/blend to transpose to columns
Redundant elements	Load once + shuffle/blend/logical to build data vectors in register. In this case, result[i] = x[index[i]] + x[index[i+1]], the technique below may be preferable to using multiple VGATHER: <pre>ymm0 <- VGATHER (x[index[k]]); // fetching 8 elements ymm1 <- VBLEND(VPERM(ymm0), VBROADCAST (x[index[k+8]]); ymm2 <- VPADD(ymm0, ymm1);</pre>

In other cases, using the VGATHER instruction can reduce code size and execute faster with techniques including but not limited to amortizing the latency and throughput of VGATHER, or by hoisting the fetch operations well in advance of consumer code of the destination register of those fetches. Example 15-44 lists some patterns that can benefit from using VGATHER on Haswell microarchitecture.

General tips for using VGATHER:

- Gathering more elements with a VGATHER instruction helps amortize the latency and throughput of VGATHER, and is more likely to provide performance benefit over an equivalent non-VGATHER flow. For example, the latency of 256-bit VGATHER is less than twice the equivalent 128-bit VGATHER and therefore more likely to show gains than two 128-bit equivalent ones. Also, using index size larger than data element size results in only half of the register slots utilized but not a proportional latency

reduction. Therefore the dword index form of VGATHER is preferred over qword index if dwords or single-precision values are to be fetched.

- It is advantageous to hoist VGATHER well in advance of the consumer code.
- VGATHER merges the (unmasked) gathered elements with the previous value of the destination. Therefore, in cases where the previous value of the destination doesn't need to be merged (for instance, when no elements is masked off), it can be beneficial to break the dependency of the VGATHER instruction on the previous writer of the destination register (by zeroing out the register with a VXOR instruction).

Example 15-44. Access Patterns Likely to Favor VGATHER Techniques

Access Patterns	Instruction Selection
4 or more elements with unknown masks	Code with conditional element gathers typically either will not vectorize without a VGATHER instruction or provide relatively poor performance due to data-dependent mis-predicted branches. C code with data-dependent branches: if (condition[i] > 0) { result[i] = x[index[i]] } AVX2 equivalent sequence: YMM0 <- VPCMPGT (condition, zeros) // compute vector mask YMM2 <- VGATHER (x[YMM1], YMM0) // addr=x[YMM1], mask=YMM0
Vectorized index calculation with 8 elements	Vectorized calculations to generate the index synergizes well with the VGATHER instruction functionality. C code snippet: x[index1[i] + index2[i]] AVX2 equivalent: YMM0 <- VPADD (index1, index2) // calc vector index YMM1 <- VGATHER (x[YMM0], mask) // addr=x[YMM0]

Performance of the VGATHER instruction compared to a multi-instruction gather equivalent flow can vary due to (1) differences in the base algorithm, (2) different data organization, and (3) the effectiveness of the equivalent flow. In performance critical applications it is advisable to evaluate both options before choosing one.

The throughput of GATHER instructions continue to improve from Broadwell to Skylake Microarchitecture. This is shown in Figure 15-4.

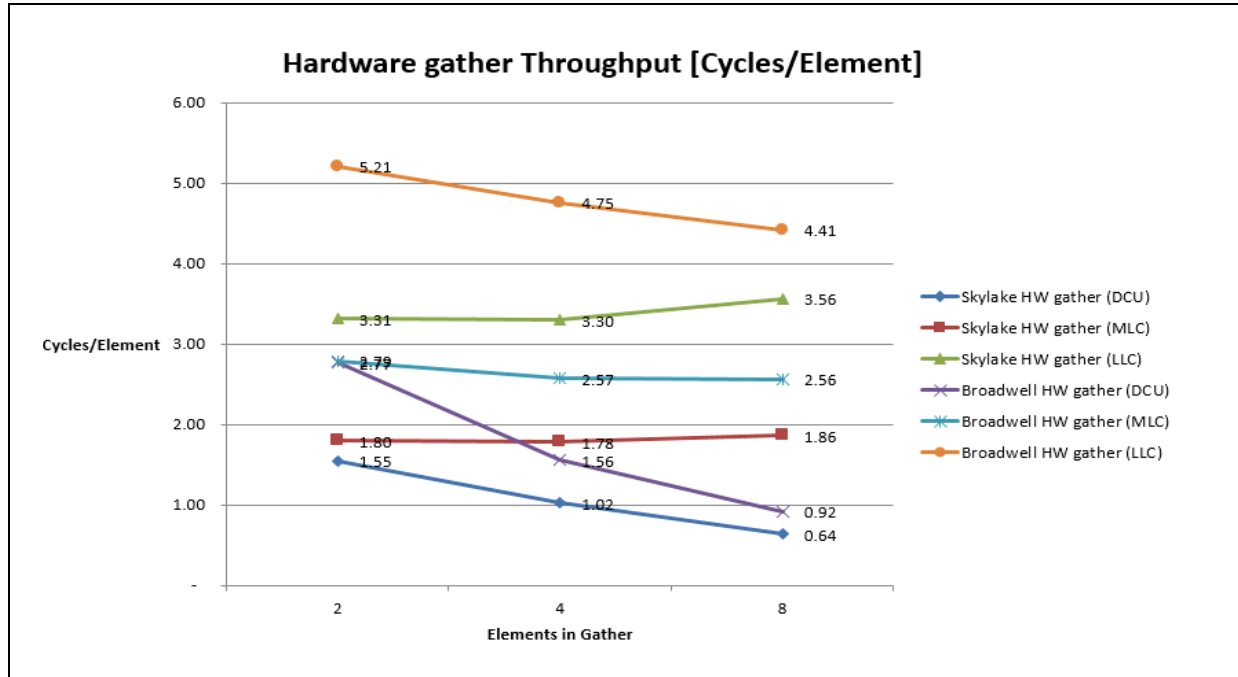

Figure 15-4. Throughput Comparison of Gather Instructions

Example 15-45 gives the asm sequence of software implementation that is equivalent to the VPGATHERD instruction. This can be used to compare the trade-off of using a hardware gather instruction or software gather sequence based on inserting an individual element.

Example 15-45. Software AVX Sequence Equivalent to Full-Mask VPGATHERD

```

mov eax, [rdi]           // load index0
vmovd xmm0, [rsi+4*rax] // load element0
mov eax, [rdi+4]        // load index1
vpinsrd xmm0, xmm0, [rsi+4*rax], 0x1 // load element1
mov eax, [rdi+8]        // load index2
vpinsrd xmm0, xmm0, [rsi+4*rax], 0x2 // load element2
mov eax, [rdi+12]       // load index3
vpinsrd xmm0, xmm0, [rsi+4*rax], 0x3 // load element3
mov eax, [rdi+16]       // load index4
vmovd xmm1, [rsi+4*rax] // load element4
mov eax, [rdi+20]       // load index5
vpinsrd xmm1, xmm1, [rsi+4*rax], 0x1 // load element5
mov eax, [rdi+24]       // load index6
vpinsrd xmm1, xmm1, [rsi+4*rax], 0x2 // load element6
mov eax, [rdi+28]       // load index7
vpinsrd xmm1, xmm1, [rsi+4*rax], 0x3 // load element7
vinserti128 ymm0, ymm0, xmm1, 1 //result in ymm0

```

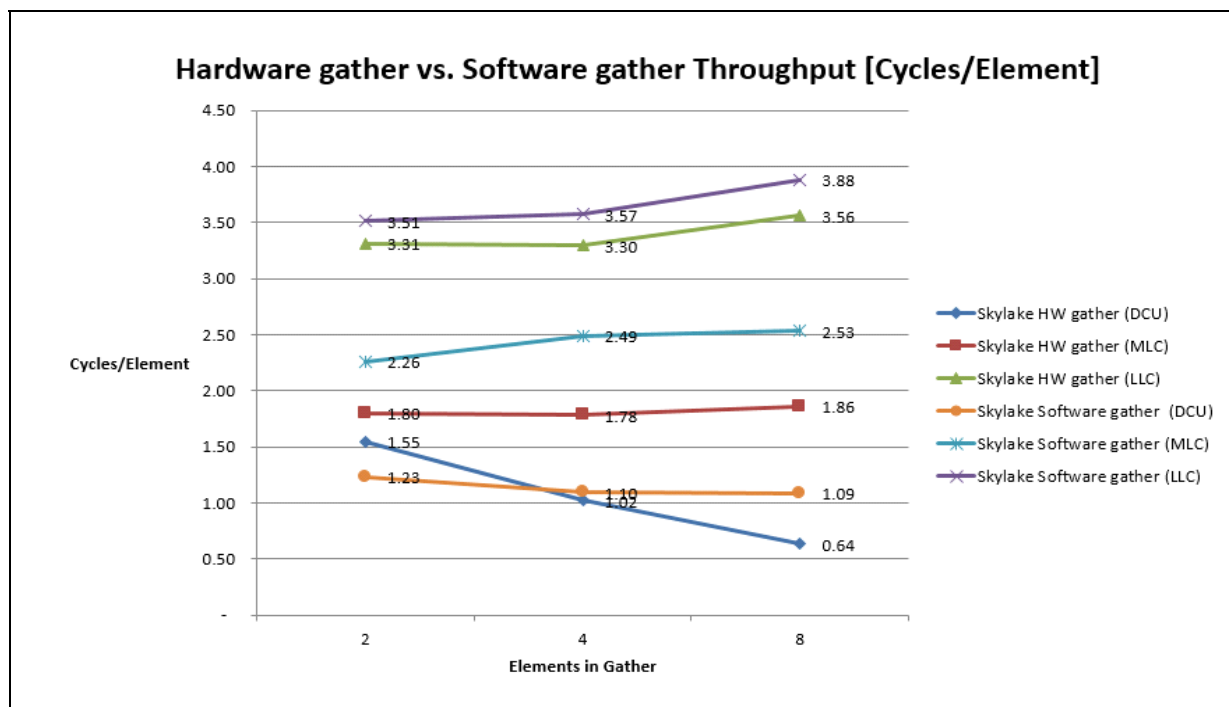

Figure 15-5. Comparison of HW GATHER Versus Software Sequence in Skylake Microarchitecture

Figure 15-5 compares per-element throughput using the VPGATHERD instruction versus a software gather sequence with Skylake microarchitecture as a function of cache locality of data supply. With the exception of using hardware GATHER on two data elements per instruction, the gather instruction outperforms the software sequence on Skylake microarchitecture.

If data supply locality is from memory, software sequences are likely to perform better than the hardware GATHER instruction.

15.16.4.1 Strided Loads

This section compares using the hardware GATHER instruction versus alternative implementations of handling Array of Structures (AOS) to Structure of Arrays (SOA) transformation. The code separates the real and imaginary elements in a complex array into two separate arrays.

C code:

```
for(int i=0;i<len;i++){
    Real_buffer[i] = Complex_buffer[i].real;
    Imaginary_buffer[i] = Complex_buffer[i].imag;
}
```

Example 15-46. AOS to SOA Transformation Alternatives

1: Scalar Code	2: AVX w/ VINSRT+VSHUFPS	3: AVX2 w/ VPGATHERD
<pre> loop: lea eax, [r10+r10*1] movsxd rax, eax inc r10d mov r11d, dword ptr [rsi+rax*8] mov dword ptr [rcx+rax*4], r11d mov r11d, dword ptr [rsi+rax*8+0x4] mov dword ptr [rdx+rax*4], r11d mov r11d, dword ptr [rsi+rax*8+0x8] mov dword ptr [rcx+rax*4+0x4], r11d mov r11d, dword ptr [rsi+rax*8+0xc] mov dword ptr [rdx+rax*4+0x4], r11d cmp r10d, r8d jl loop </pre>	<pre> loop: vmovdqu xmm0, xmmword ptr [r10+rcx*8] vmovdqu xmm1, xmmword ptr [r10+rcx*8+0x10] vmovdqu xmm4, xmmword ptr [r10+rcx*8+0x40] vmovdqu xmm5, xmmword ptr [r10+rcx*8+0x50] vinserti128 ymm2, ymm0, xmmword ptr [r10+rcx*8+0x20], 0x1 vinserti128 ymm3, ymm1, xmmword ptr [r10+rcx*8+0x30], 0x1 vinserti128 ymm6, ymm4, xmmword ptr [r10+rcx*8+0x60], 0x1 vinserti128 ymm7, ymm5, xmmword ptr [r10+rcx*8+0x70], 0x1 add rcx, 0x10 vshufps ymm0, ymm2, ymm3, 0x88 vshufps ymm1, ymm2, ymm3, 0xdd vshufps ymm4, ymm6, ymm7, 0x88 vshufps ymm5, ymm6, ymm7, 0xdd vmovups ymmword ptr [r9], ymm0 vmovups ymmword ptr [r8], ymm1 vmovups ymmword ptr [r9+0x20], ymm4 vmovups ymmword ptr [r8+0x20], ymm5 add r9, 0x40 add r8, 0x40 cmp rcx, rsi jl loop </pre>	<pre> loop: lea r11, [r10+rcx*8] vpxor ymm5, ymm5, ymm5 add rcx, 0x8 vpxor ymm6, ymm6, ymm6 vmovdqa ymm3, ymm0 vmovdqa ymm4, ymm0 vpgatherdd ymm5, ymmword ptr [r11+ymm2*4], ymm3 vpgatherdd ymm6, ymmword ptr [r11+ymm1*4], ymm4 vmovdqu ymmword ptr [r9], ymm5 vmovdqu ymmword ptr [r8], ymm6 add r9, 0x20 add r8, 0x20 cmp rcx, rsi jl loop </pre>

With strided access patterns, an AVX software sequence can load and shuffle on multiple elements and is the more optimal technique.

Table 15-7. Comparison of AOS to SOA with Strided Access Pattern

Microarchitecture	Scalar	VPGATHERD	AVX VINSRTF128/VSHUFFLEPS
Broadwell	1X	1.7X	4.8X
Skylake	1X	2.7X	4.9X

15.16.4.2 Adjacent Loads

This section compares using the hardware GATHER instruction versus alternative implementations of handling a variant situation of AOS to SOA transformation. In this case, AOS data are not loaded sequentially but via an index array.

C code:

```

for(int i=0;i<len;i++){
    Real_buffer[i] = Complex_buffer[Index_buffer[i]].real;
    Imaginary_buffer[i] = Complex_buffer[Index_buffer[i]].imag;
}

```

Example 15-47. Non-Strided AOS to SOA

AVX2 GATHERPD	AVX VINSRTF128 /UNPACK
<pre> loop: vmovdqu ymm1, ymmword ptr [rsi+rdx*4] vpadd ymm3, ymm1, ymm1 vpadd ymm14, ymm13, ymm3 vxorpd ymm5, ymm5, ymm5 vmovdqa ymm2, ymm0 vxorpd ymm6, ymm6, ymm6 vmovdqa ymm4, ymm0 vxorpd ymm10, ymm10, ymm10 vmovdqa ymm7, ymm0 vxorpd ymm11, ymm11, ymm11 vmovdqa ymm9, ymm0 vextracti128 xmm12, ymm14, 0x1 vextracti128 xmm8, ymm3, 0x1 vgatherdpd ymm6, ymmword ptr[r8+xmm8*8], ymm4 vgatherdpd ymm5, ymmword ptr[r8+xmm3*8], ymm2 vmovupd ymmword ptr [rcx+rdx*8], ymm5 vmovupd ymmword ptr [rcx+rdx*8+0x20], ymm6 vgatherdpd ymm11, ymmword ptr[r8+xmm12*8], ymm7 vgatherdpd ymm10, ymmword ptr[r8+xmm14*8], ymm9 vmovupd ymmword ptr [rax+rdx*8], ymm10 vmovupd ymmword ptr [rax+rdx*8+0x20], ymm11 add rdx, 0x8 cmp rdx, r11 jb loop </pre>	<pre> loop: movsxd r10, dword ptr [rdx+rsi*4] shl r10, 0x4 movsxd r11, dword ptr [rdx+rsi*4+0x8] shl r11, 0x4 vmovupd xmm0, xmmword ptr [r9+r10*1] movsxd r10, dword ptr [rdx+rsi*4+0x4] shl r10, 0x4 vinsertf128 ymm2, ymm0, xmmword ptr [r9+r11*1], 0x1 vmovupd xmm1, xmmword ptr [r9+r10*1] movsxd r10, dword ptr [rdx+rsi*4+0xc] shl r10, 0x4 vinsertf128 ymm3, ymm1, xmmword ptr [r9+r10*1], 0x1 movsxd r10, dword ptr [rdx+rsi*4+0x10] shl r10, 0x4 vunpcklpd ymm4, ymm2, ymm3 vunpckhpd ymm5, ymm2, ymm3 vmovupd ymmword ptr [rcx], ymm4 vmovupd xmm6, xmmword ptr [r9+r10*1] vmovupd ymmword ptr [rax], ymm5 movsxd r10, dword ptr [rdx+rsi*4+0x18] shl r10, 0x4 vinsertf128 ymm8, ymm6, xmmword ptr [r9+r10*1], 0x1 movsxd r10, dword ptr [rdx+rsi*4+0x14] shl r10, 0x4 vmovupd xmm7, xmmword ptr [r9+r10*1] movsxd r10, dword ptr [rdx+rsi*4+0x1c] add rsi, 0x8 shl r10, 0x4 vinsertf128 ymm9, ymm7, xmmword ptr [r9+r10*1], 0x1 vunpcklpd ymm10, ymm8, ymm9 vunpckhpd ymm11, ymm8, ymm9 vmovupd ymmword ptr [rcx+0x20], ymm10 add rcx, 0x40 vmovupd ymmword ptr [rax+0x20], ymm11 add rax, 0x40 cmp rsi, r8 jl loop </pre>

With non-strided, regular access pattern of AOS to SOA, an AVX software sequence that uses VINSERTF128 and interleaved packing of multiple elements can be more optimal.

Table 15-8. Comparison of Indexed AOS to SOA Transformation

Microarchitecture	VPGATHERPD	AVX VINSRTF128/VUNPCK*
Broadwell	1X	1.4X
Skylake	1.3X	1.7X

15.16.5 AVX2 Conversion Remedy to MMX Instruction Throughput Limitation

In processors based on the Skylake microarchitecture, the functionality of the MMX instruction set is unchanged from prior generations. But many MMX instructions are constrained to execute to one port with half the instruction throughput relative to prior microarchitectures. The MMX instructions with throughput constraints include:

- PADDQ[B/W], PADDUS[B/W], PSUBQ[B/W], PSUBUS[B/W].
- PCMPGT[B/W/D], PCMPEQ[B/W/D].
- PMAX[UB/SW], PMIN[UB/SW].
- PAVG[B/W], PABS[B/W/D], PSIGN[B/W/D].

To overcome the reduction of MMX instruction throughput, conversion of asm and intrinsic code to use AVX2 instruction will provide significant performance improvements. Example 15-48 shows the asm sequence using AVX2 versus MMX equivalent. In Skylake microarchitecture, the MMX code shown in Example 15-48 will execute at approximately half the speed relative to the Broadwell microarchitecture. This is due to PMAXSW/PMINSW throughput being reduced by half with the single-port restriction. When the same task is implemented with the equivalent AVX2 sequence, the performance of the AVX2 code on Skylake microarchitecture will be ~3.9X of the MMX code executing on the Broadwell microarchitecture.

Example 15-48. Conversion to Throughput-Reduced MMX sequence to AVX2 Alternative

MMX Code	AVX2 Code
<pre> mov rax, pln mov rbx, pOut mov r8, len mov rcx, 8 movq mm0, [rax] movq mm1, [rax + 8] movq mm2, mm0 movq mm3, mm1 cmp rcx, r8 jge end loop: movq mm4, [rax + 2*rcx] movq mm5, [rax + 2*rcx + 8] pmaxsw mm0, mm4 pmaxsw mm1, mm5 pminsw mm2, mm4 pminsw mm3, mm5 add rcx, 8 cmp rcx, r8 jl loop end: //Reduction pmaxsw mm0, mm1 pshufw mm1, mm0, 0xE pmaxsw mm0, mm1 pshufw mm1, mm0, 1 pmaxsw mm0, mm1 pminsw mm2, mm3 pshufw mm3, mm2, 0xE pminsw mm2, mm3 pshufw mm3, mm2, 1 pminsw mm2, mm3 movd eax, mm0 mov WORD PTR [rbx], ax movd eax, mm2 mov WORD PTR [rbx + 2], ax emms </pre>	<pre> mov rax, pln mov rbx, pOut mov r8, len mov rcx, 32 vmovdqu ymm0, ymmword ptr [rax] vmovdqu ymm1, ymmword ptr [rax + 32] vmovdqu ymm2, ymm0 vmovdqu ymm3, ymm1 cmp rcx, r8 jge end loop: vmovdqu ymm4, ymmword ptr [rax + 2*rcx] vmovdqu ymm5, ymmword ptr [rax + 2*rcx + 32] vpmaxsw ymm0, ymm0, ymm4 vpmaxsw ymm1, ymm1, ymm5 vpminsw ymm2, ymm2, ymm4 vpminsw ymm3, ymm3, ymm5 add rcx, 32 cmp rcx, r8 jl loop end: //Reduction vpmaxsw ymm0, ymm0, ymm1 vextracti128 xmm1, ymm0, 1 vpmaxsw xmm0, xmm0, xmm1 vpshufd xmm1, xmm0, 0xe vpmaxsw xmm0, xmm0, xmm1 vpshufw xmm1, xmm0, 0xe vpmaxsw xmm0, xmm0, xmm1 vpshufw xmm1, xmm0, 1 vpmaxsw xmm0, xmm0, xmm1 vmovd eax, xmm0 mov word ptr [rbx], ax vpminsw ymm2, ymm2, ymm3 vextracti128 xmm1, ymm2, 1 vpminsw xmm2, xmm2, xmm1 vpshufd xmm1, xmm2, 0xe vpminsw xmm2, xmm2, xmm1 vpshufw xmm1, xmm2, 0xe vpminsw xmm2, xmm2, xmm1 vpshufw xmm1, xmm2, 1 vpminsw xmm2, xmm2, xmm1 vmovd eax, xmm2 mov word ptr [rbx + 2], ax </pre>

16.1 INTRODUCTION

Intel® Transactional Synchronization Extensions (Intel TSX) aim to improve the performance of lock-protected critical sections while maintaining the lock-based programming model.

Intel TSX allows the processor to determine dynamically whether threads need to serialize through lock-protected critical sections, and to perform serialization only when required. This lets hardware expose and exploit concurrency hidden in an application due to dynamically unnecessary synchronization through a technique known as lock elision.

With lock elision, the hardware executes the programmer-specified critical sections (also referred to as **transactional regions**) transactionally. In such an execution, the lock variable is only read within the transactional region; it is not written to (and therefore not acquired), with the expectation that the lock variable remains unchanged after the transactional region, thus exposing concurrency.

If the transactional execution completes successfully, then the hardware ensures that all memory operations performed within the transactional region will appear to have occurred instantaneously when viewed from other logical processors. A processor makes architectural updates performed within the region visible to other logical processors only on a successful commit, a process referred to as an **atomic commit**. Any updates performed within the transactional region are made visible to other logical processors only on an atomic commit.

Since a successful transactional execution ensures an atomic commit, the processor can execute the programmer-specified code section optimistically without synchronization. If synchronization was unnecessary for that specific execution, execution can commit without any cross-thread serialization.

If the transactional execution is unsuccessful, the processor cannot commit the updates atomically. When this happens, the processor will roll back the execution, a process referred to as a **transactional abort**. On a transactional abort, the processor will discard all updates performed in the region, restore architectural state to appear as if the optimistic execution never occurred, and resume execution non-transactionally. Depending on the policy in place, lock elision may be retried or the lock may be explicitly acquired to ensure forward progress.

Intel TSX provides two software interfaces to programmers:

- **Hardware Lock Elision** (HLE) is a legacy compatible instruction set extension (comprising of the XACQUIRE and XRELEASE prefixes).
- **Restricted Transactional Memory** (RTM) is a new instruction set interface (comprising of the XBEGIN and XEND instructions).

Programmers who would like to run Intel TSX enabled software on legacy hardware would use the HLE interface to implement lock elision. On the other hand, programmers who do not have legacy hardware requirements and who deal with more complex locking primitives would use the RTM interface of Intel TSX to implement lock elision. In the latter case when using new instructions, the programmer must always provide a non-transactional path (which would have code to eventually acquire the lock being elided) to execute following a transactional abort and must not rely on the transactional execution alone.

In addition, Intel TSX also provides the XTEST instruction to test whether a logical processor is executing transactionally, and the XABORT instruction to abort a transactional region.

A processor can perform a transactional abort for numerous reasons. A primary cause is due to conflicting data accesses between the transactionally executing logical processor and another logical processor. Such conflicting accesses may prevent a successful transactional execution. Memory addresses read from within a transactional region constitute the **read-set** of the transactional region and addresses written to within the transactional region constitute the **write-set** of the transactional region. Intel TSX maintains the read- and write-sets at the granularity of a cache line. For lock elision using RTM, the address of the lock being elided must be added to the read-set to ensure correct behavior of a transactionally executing thread in the presence of another thread that explicitly acquires the lock.

A conflicting data access occurs if another logical processor either reads a location that is part of the transactional region's write-set or writes a location that is a part of either the read- or write-set of the transactional region. We refer to this as a **data conflict**. Since Intel TSX detects data conflicts at the granularity of a cache line, unrelated data locations placed in the same cache line will be detected as conflicts. Transactional aborts may also occur due to limited transactional resources. For example, the amount of data accessed in the region may exceed an implementation-specific capacity. Some instructions, such as CPUID and IO instructions, may always cause a transactional execution to abort in the implementation.

Details of the Intel TSX interface can be found in Chapter 16 of *Intel® 64 and IA-32 Architectures Software Developer's Manual, Volume 1*.

The rest of this chapter provides guidelines for software developers to use the Intel TSX instructions. The guidelines focus on the use of the Intel TSX instructions to implement lock elision to enable concurrency of lock-protected critical sections, whether through the use of prefix hints as with HLE or through the use of new instructions as with RTM. Programmers may find other usages of the Intel TSX instructions beyond lock elision; those usages are not covered here.

In the sections below, we use the term **lock elision** to refer to either an **HLE**-based or an **RTM**-based implementation that elides locks.

16.1.1 Optimization Outline

This rest of this chapter describes the recommended approach for optimization and tuning of multi-threaded applications to use the Intel TSX instructions for lock elision. The focus of Intel TSX is to improve application performance (See Section 16.2) instead of synthetic micro-kernels that tend to overlook how real applications behave after acquiring a lock. We also discuss how to enable a synchronization library for lock elision using Intel TSX (See Section 16.3). We then discuss how to use the performance monitoring infrastructure for Intel TSX effectively (See Section 16.4) and present some performance guidelines for the first implementation (See Section 16.5).

The recommended guideline is to enable elision for all critical section locks and then identify problematic critical sections. Such a "bottoms-up" approach simplifies the evaluation and tuning of the resulting application and allows the programmer to focus on relevant critical sections.

Additional resources for TSX tuning are available at <http://www.intel.com/software/tsx>.

16.2 APPLICATION-LEVEL TUNING AND OPTIMIZATIONS

Applications typically use **synchronization libraries** to implement the lock acquire and lock release functions associated with critical sections. The simplest way to enable these applications to take advantage of Intel TSX-based lock elision is to use an Intel TSX-enabled synchronization library. Existing libraries may be already enabled to take advantage of the Intel TSX instructions (see Section 16.2.1). If an off-the-shelf, TSX-enabled library is not yet available, Section 16.3 discusses how to extend a locking library to use the Intel TSX instructions if it has not already been enabled. TSX-enabled synchronization libraries can be interchangeably used with conventional synchronization libraries.

While applications using these libraries can use Intel TSX without application modification, some basic tuning and profiling can improve performance by increasing the commit rate of transactional execution and by lowering the wasted execution cycles due to transactional aborts. The recommended first step for tuning is to use a profiling tool (see Section 16.4) to characterize the transactional behavior of the application. The profiling tool uses the performance monitoring and sampling capabilities implemented in the hardware to provide detailed information about the transactional behavior of the application. The tool uses capabilities provided by the processor such as performance monitoring counters and the Precise Event Based Sampling (PEBS) mechanism, see chapter 18 of *Intel® 64 and IA-32 Architectures Software Developer's Manual, Volume 3B*.

Applications using an Intel TSX-enabled synchronization library should have the same functional behavior as if they were using a conventional synchronization library. However, because Intel TSX

changes latencies and can make cross-thread synchronization faster than before, latent bugs in the code may be exposed.

16.2.1 Existing TSX-enabled Locking Libraries

This section summarizes off-the-shelf locking libraries that are already TSX-enabled for lock elision. The list is non-exhaustive and represents a snap shot as of the first half of 2015. Not all libraries mentioned here may be completely tuned.

16.2.1.1 Libraries allowing lock elision for unmodified programs

- On Linux, GNU glibc 2.18 added support for lock elision of pthread mutexes of PTHREAD_MUTEX_DEFAULT type. Glibc 2.19 added support for elision of read/write mutexes. Whether elision is enabled, depends whether the `--enable-lock-elision=yes` parameter was set at compilation time of the library.
- Java JDK 8u20 or later support adaptive elision for synchronized sections when the `-XX:+UseRTMLocking` option is enabled.
- Intel Composer XE 2013 SP1 or later supports lock elision for OpenMP `omp_lock_t`. Use `export KMP_LOCK_KIND=adaptive` to enable lock elision.

16.2.1.2 Libraries requiring program modifications

- Intel Thread Building Blocks (TBB) 4.2 supports elision with the `speculative_spin_rw_mutex`. The program needs to be modified to use this new lock type.
- gcc 4.8 and later supports TSX acceleration of its software transactional memory implementation.
- Concurrency Kit supports lock elision of spinlocks with its `ck_elide` wrappers.
- DPDK library supports lock elision of spin locks and read-write locks (through lock/unlock calls with `“_tm”` suffix).

16.2.2 Initial Checks

A couple of simple sanity checks can save tuning effort later on; specifically, using a good library implementation and dealing with statistics collection inside critical sections.

- Use a good Intel TSX enabled synchronization library. The application should directly be using the TSX-enabled synchronization library. When the application implements its own custom library built on top of an Intel TSX-enabled library, it still may be missing opportunities to identify transactional regions. See Section 3 on how to enable the synchronization library for Intel TSX.
- Avoid collecting statistics inside critical sections. Critical sections (and sometimes the synchronization library itself) may employ shared global statistics counters. Such counters will cause data conflicts and transactional aborts. Applications often have flags to disable such statistics collection. Disabling such statistics in the initial tuning phase will help focus on inherent data conflicts.

16.2.3 Run and Profile the Application

Visualizing synchronization-related thread interactions in multi-threaded applications is often difficult. The first step should be to run the application with an Intel TSX-enabled synchronization library and measure performance. Next, the profiling tool should be used to understand the result. First we should determine how much of the application is actually employing transactional execution, by using a profiling tool to measure the percentage of the application cycles spent in transactional execution (See Section 16.4).

Numerous causes may contribute to a low percentage of transactional execution cycles:

- The application may not be making noticeable use of critical-section based synchronization. In this case, lock elision is not going to provide benefits.

- The application's synchronization library may not use Intel TSX for all its primitives. This can occur if the application uses internal custom functions and libraries for some of the critical section locks. These lock implementations need to be identified and modified for elision (See Section 16.4.2).
- The application may be employing higher level locking constructs (referred to as meta-locks in this document) different from the one provided by the elision-enabled synchronization libraries. In these cases, the construct needs to be identified and enabled for elision (See Section 16.3.7)
- A program may be using LOCK-prefixed instructions for usages other than critical sections. TSX will not help with these typically, unless the algorithms are adapted to be transactional. Details on such non-locking usage are beyond the scope of this guide.

In the "bottom-up" approach of Intel TSX performance tuning, the methodology can be modularized into the following tasks:

- Identify all locks.
- Run the unmodified program with a TSX synchronization library eliding all locks.
- Use a profiling tool to measure transactional execution.
- Address causes of transactional aborts if necessary.

16.2.4 Minimize Transactional Aborts

Data conflicts are detected through the cache coherence protocol. Data conflicts cause transactional aborts. In the initial implementation, the thread that detects the data conflict will transactionally abort.

If an HLE-based transactional execution experiences a transactional abort, then in the current implementation, the hardware will restart at the XACQUIRE prefixed instruction that initiated HLE execution but will ignore the XACQUIRE prefix. This results in the re-execution without lock elision and the lock is explicitly acquired. If an RTM-based transactional execution experiences a transactional abort, then in the current implementation, the hardware will restart at the instruction address provided by the operation of the XBEGIN instruction.

The initial TSX implementation supports a limited form of nesting. RTM supports a nesting level of 7. HLE supports a nesting level of 1. This is an implementation specific number that may change in subsequent implementations of the same generation of processor families.

The Chapter 16 of *Intel® 64 and IA-32 Architectures Software Developer's Manual, Volume 1* also describes the various causes for transactional aborts in detail. Details of Intel TSX instructions and prefixes can be found in *Intel® 64 and IA-32 Architectures Software Developer's Manual, Volume 2B*.

The profiling tool can use performance monitoring to compute cycles that were spent in transactional execution that subsequently aborted. It is important to note that not all transactional aborts cause performance loss. The execution may otherwise have stalled due to waiting on a lock that had been acquired by another thread, and the transactional execution may also have a data prefetching effect.

The profiling tool can use PEBS to identify the top aborted transactional regions and provide information on the relative costs (see Section 16.4). We next discuss common causes for transactional aborts and provide mitigation strategies.

Tuning Suggestion 4. *Use a profiling tool to identify the transactional aborts that contribute most to any performance loss.*

The broad categories for transactional abort causes include:

- Aborts due to conflicting data accesses.
- Aborts due to conflicts on the lock variable.
- Aborts due to exceeding resource buffering.
- Aborts due to HLE interface specific constraints.
- Miscellaneous aborts as described in Chapter 8 of the *Intel® Architecture Instruction Set Extensions Programming Reference*.

16.2.4.1 Transactional Aborts due to Data Conflicts

A data conflict occurs if another logical processor either reads a location that is part of the transactional region's write-set or writes a location that is a part of either the read- or write-set of the transactional region. In the initial implementation, data conflicts are detected through the cache coherence protocol that operates at the granularity of a cache line.

We now discuss various sources of data conflicts that can cause transactional aborts. Some are avoidable while others are inherently present in the application.

Conflicts due to False Sharing

False sharing occurs when unrelated variables map to the same cache line (64 bytes) and are independently written by different threads. In this case, although the addresses of the unrelated variables do not overlap, since the hardware checks data conflicts at cache-line granularity, these unrelated variables appear to have the same address and this causes unnecessary transactional aborts.

Note that negative effects of false sharing are not unique to Intel TSX. The cache coherence protocol is moving the cache line around the system with high overhead. Good software practice already recommends against placing unrelated variables on the same cache line when at least one of the variables is frequently written by different threads.

Tuning Suggestion 5. *Add padding to put the two conflicting variables in separate cache line.*

Tuning Suggestion 6. *Reorganize the data structure to minimize false sharing whenever possible.*

Conflicts due to True Sharing

These transactional aborts occur if the conflict data is actually shared and is not due to false sharing. Sometimes such conflicts can also be mitigated through software changes. We discuss how to address some of these conflicts next.

Conflicts due to Statistics Maintenance

Software may often use global statistics counters shared among multiple threads. Examples of such use include synchronization libraries that count the number of times a critical section lock is either successfully acquired or was found to be held. Other examples include a count in a global variable or in an object that is accessed by multiple threads. Such statistics contribute to transactional aborts. In such cases, one must first try to understand the use of such statistics.

Sometimes these statistics can be disabled or conditionally skipped as they do not affect program logic. For example, such statistics may be measuring the frequency of serialized execution of a critical section. Without lock elision, the statistic is updated inside the critical section as the execution is already serialized. However, if the lock has been elided, then counting the number of times the lock has been elided isn't particularly useful. The only time it matters is if the lock was not elided; in those situations, the software can use the statistics to track the level of serialization. The XTEST instruction can be used to update the statistics only when the execution is not eliding a lock (i.e., serialized). Sometimes these statistics are only useful during program development and can be disabled in production software.

In some cases these statistics cannot be disabled or skipped. The programmer can avoid unnecessary transactional aborts by maintaining these statistics per logical thread (while taking care to avoid false sharing). Such an approach requires results to be aggregated across all threads when read. This can also improve the performance of applications even without Intel TSX instructions by minimizing communication among various threads.

Other approaches include moving the statistic outside critical sections and using an atomic operation to update the statistic. This will reduce transactional aborts but may add additional overhead due to an additional atomic operation and will not reduce the communication overhead.

Tuning Suggestion 7. *Global statistics may also be sampled rather than being updated for every operation.*

Tuning Suggestion 8. *Avoid unnecessary statistics in critical sections.*

Tuning Suggestion 9. *Consider maintaining statistics in critical sections on a per-thread basis.*

The programmer will have to determine the best approach for reducing transactional aborts due to shared global statistics. Disabling all global statistics during initial testing can help identify whether they are a problem.

Conflicts due to Accounting in Data Structures

Another common source of data conflicts are accounting operations in data structures. For example, data structures may maintain a variable to track the number of entries present at any time. This has the same effect as a statistics counter and can cause unnecessary transactional aborts.

In some usages, it is possible to move the accounting update to outside the critical section using atomic updates (e.g., the number of entries to trigger heap reorganization).

In other scenarios, approaches may be adopted to reduce the window of time where data conflicts may occur (see Section 16.2.4.1 on Reducing the Window for Data Conflict).

Conflicts in Memory Allocators

Some critical sections perform memory allocations. It is recommended to use a thread-friendly memory allocation library that maintains its free list in thread local space and avoid false sharing of the allocated memory.

Conflict Reduction through Conditional Writes

A common software pattern involves updates to a shared variable or flag that only infrequently changes value. Such an operation (even with the same value) causes an update to the cache line, which may in turn result in the processor requesting write-permissions to the cache line. Such an operation will cause transactional aborts in other threads that are also accessing the shared variable. Software can avoid such data conflicts by performing the update only when necessary - not performing the store if the value doesn't change, see Example 16-1.

Example 16-1. Reduce Data Conflict with Conditional Updates

state = true; // updates every time var = flag;	if (state != true) state = true; if (!(var & flag)) var = flag;
---	---

Reducing the Window for Data Conflict

Sometimes the techniques described are insufficient to avoid transactional aborts due to frequent real data conflicts. In such cases, the goal should be to reduce the window of time where a data conflict can occur. To reduce this probability, one may move the actual conflicting memory access towards the end of the critical section.

16.2.4.2 Transactional Aborts due to Limited Transactional Resources

While an Intel TSX implementation provides sufficient resources for executing common transactional regions, implementation constraints and excessive data footprint for transactional regions may cause a transactional abort. The architecture provides neither a guarantee of the resources available for transactional execution nor that a transactional execution will ever succeed.

The processor tracks both the **read-set** addresses and the **write-set** addresses in the first level data cache (L1 cache) of the processor.

An eviction of a read set address may not always result in an immediate transactional abort since these lines may be tracked in an implementation-specific second level structure. In current implementations, the second level structure tracks evicted read-set addresses probabilistically. As a result, accesses from other threads may at times result in a false positive match thus causing an unnecessary transactional abort. The rate of such false conflicts is a function of the address stream from different threads and the precise hardware implementation. The Broadwell microarchitecture implementation has an improved

second level structure. The rate of false conflicts is expected to reduce further with future implementations.

The architecture does not provide any guarantee for buffering and software must not assume any such guarantee.

With Haswell, Broadwell and Skylake microarchitectures, the L1 data cache has an associativity of 8. This means that in this implementation, a transactional execution that writes to 9 distinct locations mapping to the same cache set will abort. However, due to microarchitectural implementations, this does not mean that fewer accesses to the same set are guaranteed to never abort.

Additionally, in configurations with Intel Hyper-Threading Technology, the L1 cache is shared between the two logical processors on the same core, so operations in a sibling logical processor of the same core can cause evictions and significantly reduce the effective read and write set sizes.

Use the profiler to identify transactional regions that frequently abort due to capacity limitations (see Section 16.4.4). Software should avoid accessing excessive data within such transactional regions. Since, in general, accessing large amounts of data takes time, such aborts result in an excessive wasted execution cycles.

Sometimes, the data footprint of the critical section can be reduced by changing the algorithm. For example, for a sorted array, a binary instead of a linear search could be used to reduce the number of addresses accessed within the critical section.

If the algorithm expects certain code paths in the transactional region to access excessive data it may force an early transactional abort (through the XABORT instruction) or transition into a non-transactional execution without aborting by first acquiring the elided locks (see Section 16.2.6).

Sometimes, capacity aborts may occur due to side effects of actions inside a transactional region. For example, if an application invokes a dynamic library function for the first time the software system has to invoke the dynamic linker to resolve the symbols. If this first time happens inside a transactional region, it may result in excessive data being accessed, and thus will typically cause an abort. These types of aborts happen only the first time such a function is invoked. If this happens often, it is likely due to transactional only path not used in a non-transactional execution.

16.2.4.3 Lock Elision Specific Transactional Aborts

In addition to conflicts on data, transactional aborts may also occur due to conflicts on the lock itself. This is necessary to detect a transactional execution and a non-transactional execution of the critical section overlap in time. When implementing lock elision through Intel TSX, the implementation adds the lock to the read set - this occurs automatically for HLE but must be explicitly done in the software library when using RTM for lock elision. This allows checking conflicts with other threads that explicitly acquire the lock. This is a natural part of a transactional execution that aborts and re-starts and eventually acquires the lock.

For lock elision with HLE and RTM, many observed aborts occur due to such secondary conflicts on the lock variable: an aborting transactional thread transitions to a regular non-transactional execution, and as part of the transition also explicitly acquires the lock. This lock acquisition causes other transactionally executing threads to abort as they must serialize behind the thread that just acquired the lock.

For RTM, the fallback handler can potentially reduce these secondary aborts by waiting for the lock to be free before trying to acquire the lock (see Section 16.3.5).

16.2.4.4 HLE Specific Transactional Aborts

Some transactional aborts only occur in HLE-based lock elision. They are described in subsequent sections.

Unsupported Lock Elision Patterns

For the transactional execution to commit successfully, the lock must satisfy certain properties and access to the lock must follow certain guidelines. An XRELEASE-prefixed instruction must restore the value of the elided lock to the value it had before the corresponding XACQUIRE-prefixed lock acquisition.

This allows hardware to elide locks safely without adding them to the write-set. Both the data size and data address of the lock release (XRELEASE-prefixed) instruction must match that of the lock acquire (XACQUIRE-prefixed) and the lock must not cross a cache line boundary. For example, an XACQUIRE-prefixed lock acquire to an address A followed by an XRELEASE-prefixed lock release to a different address B will abort since the addresses A and B do not match.

Unsupported Access to Lock Variables inside HLE regions

Typically, a lock variable can be read from inside an HLE region without aborting. However, certain uncommon types of accesses may cause transactional aborts. For example, performing an unaligned access or a partially overlapping access to an elided lock variable will cause a transactional abort. Software should be changed to perform properly aligned accesses to the elided lock variable.

Software should not write to the elided lock inside a transactional HLE region with any instruction other than an XRELEASE prefixed instruction, otherwise it will cause a transactional abort.

16.2.4.5 Miscellaneous Transactional Aborts

Programmers can use any instruction safely inside a transactional region and can use transactional regions at any privilege level. However, some instructions will always abort the transactional execution and cause execution to seamlessly and safely transition to a non-transactional path. Such transactional aborts will appear as Instruction Aborts in the PEBS record transactional abort status collected by the profiling tool (see Section 16.4).

The Intel SDM presents a comprehensive list of such instructions. Common examples include instructions that operate on the X87 and MMX architecture state, operations that update segment, control, and debug registers, IO instructions, and instructions that cause ring transitions, such as SYSENTER, SYSCALL, SYSEXIT, and SYSRET.

Programmers should use SSE/AVX instructions instead of X87/MMX instructions inside transactional regions. However, programmers must be careful when inter-mixing SSE and AVX operations inside a transactional region. Intermixing SSE instructions accessing XMM registers and AVX instructions accessing YMM registers may cause transactional regions to abort. The VZEROUPPER instruction may also cause an abort, and programmers should try to move the instruction to prior to the critical section.

Certain 32-bit calling conventions may use X87 state to pass or return arguments. Programmers should consider alternate calling conventions or inline the functions. Some types such as long double may use X87 instructions and should be avoided.

In addition to the instruction-based considerations, various runtime events may cause transactional execution to abort.

Asynchronous events (NMI, SMI, INTR, IPI, PMI, etc.) occurring during transactional execution may cause the transactional execution to abort and transition to a non-transactional execution. The rate of such aborts depends on the background state of the operating system. For example, operating systems with timer ticks generate interrupts that can cause transactional aborts.

Synchronous exception events (#BR, #PF, #DB, #BP/INT3, etc.) that occur during transactional execution may cause an execution not to commit transactionally, and require a non-transactional execution. These events are suppressed as if they had never occurred.

Page faults (#PF) typically occur most when a program starts up. Transactional regions will experience aborts at a higher rate during this period since pages are being mapped for the first time. These aborts will disappear as the program reaches a steady state behavior. However, for programs with very short run times, these aborts may appear to dominate. A similar behavior happens when large regions of memory were allocated in the recent past.

Memory accesses within a transactional region may require the processor to set the Accessed and Dirty flags of the referenced page table entry. These actions occur on the first access and write to the page, respectively. These operations will cause a transactional abort in the current implementation. A re-execution in non-transactional mode will cause these bits to be appropriately updated and subsequent transactional executions will typically not observe these transactional aborts. Although these transac-

tional aborts will show up as Instruction Aborts in the PEBS record transactional abort status, special attention isn't needed unless they occur frequently.

In addition to the above, implementation-specific conditions and background system activity may cause transactional aborts. Examples include aborts as a result of the caching hierarchy of the system, subtle interactions with processor micro-architecture implementations, and interrupts from system timers among others. Aborts due to such activity are expected to be fairly infrequent for typical Intel TSX usage for lock elision.

Tuning Suggestion 10. *Transactional regions during program startup may observe a higher abort rate than during steady state.*

Tuning Suggestion 11. *Operating system services may cause infrequent transactional aborts due to background activity.*

16.2.5 Using Transactional-Only Code Paths

With Intel TSX, programmers can write code that is only ever executed in a transactional region and the non-transactional fallback path may be different. This is possible with RTM (through the use of the fallback handler) and with HLE in conjunction with the XTEST instruction.

Care is required if the code executed during transactional execution is significantly different than the code executed when not in transactional execution. Certain events such as page faults (instruction and data) and operations on pages that modify the accessed and dirty bits may repeatedly abort a transactional execution. Thus programmers must ensure such operations are also performed in a non-transactional fallback path, otherwise the transactional region may never succeed. This is not a problem in general since with lock elision the transactional path and non-transactional path in the application is the same and the only differences are captured in the synchronization libraries.

The XTEST instruction can be used to skip over code sequences that are unnecessary during transactional execution and likely to lead to aborts. The XTEST instruction can also be used to implement optimizations such as skipping unwind code and other error handling code (such as deadlock detection) that is only required if the lock is actually acquired.

Tuning Suggestion 12. *Keep any transactional only code paths simple and inlined.*

Tuning Suggestion 13. *Minimize code paths that are only executed transactionally.*

16.2.6 Dealing with Transactional Regions or Paths that Abort at a High Rate

Some transactional regions abort at a high rate and the methods discussed so far are not effective in reducing the aborts. In such cases, the following options may be considered.

16.2.6.1 Transitioning to Non-Elided Execution without Aborting

Sometimes, a transactional abort is unavoidable. Examples include system calls, and IO operations. When these are required on a transactional code path, software using RTM for lock elision can transition to a non-elided execution by attempting to acquire the lock and if successful committing the transactional execution. A simplified example is shown in Example 16-2. The actual code may need to handle nesting, etc.

Example 16-2. Transition from Non-Elided Execution without Aborting

```

/* ... in RTM transaction, but the transactional execution will abort */
/* Acquire the lock without elision */

<original lock acquire code>
_xend(); /* Commit */

/* Do aborting operation */

```

16.2.6.2 Forcing an Early Abort

Programmers should try to insert a PAUSE or XABORT instruction early in paths that lead to aborts inside transactional regions. This will force a transactional abort early and minimize work that needs to be discarded.

16.2.6.3 Not Eliding Selected Locks

Sometimes if the application performance is lower with lock elision and the transactional abort reduction techniques have been exhausted, software can disable elision for the specific locks that have high and expensive transactional abort rates. This should always be validated with application level performance metrics, as even high abort rates may still result in a performance improvement.

16.3 DEVELOPING AN INTEL TSX ENABLED SYNCHRONIZATION LIBRARY

This section describes how to enable a synchronization library for lock elision using the Intel TSX instructions.

16.3.1 Adding HLE Prefixes

The programmer uses the XACQUIRE prefix in front of the instruction that is used to acquire the lock that is protecting the critical section. The programmer uses the XRELEASE prefix in front of the instruction that is used to release the lock protecting the critical section. This instruction will be a write to the lock. If the instruction is restoring the value of the lock to the value it had prior to the XACQUIRE prefixed lock acquire operation on the same lock, then the processor elides the external write request associated with the release of the lock, enabling concurrency in the absence of data conflicts.

16.3.2 Elision Friendly Critical Section Locks

The library itself shouldn't be a source of data conflicts. Common examples of such problems include:

- Conflicts on the lock owner field.
- Conflicts on lock-related statistics.

When using HLE for lock elision, programmers must add the elision capability to the existing code path (since the code path executed with and without elision is the same with HLE). The programmer should also check that the only write operation to a shared location is through the lock-acquire/lock-release instructions on the lock variable. Any other write operation to a shared location would typically manifest itself as a data conflict among two threads using the elision library to elide a common lock. A test running multiple threads looping through an empty critical section protected by a shared lock can quickly identify such situations.

16.3.3 Using HLE or RTM for Lock Elision

Software can use the CPUID information to determine whether the processor supports the HLE and RTM extensions. However, software can use the HLE prefixes (XACQUIRE and XRELEASE) without checking whether the processor supports HLE. Processors without HLE support ignore these prefixes and will execute the code without entering transactional execution. In contrast, software must check if the processor supports RTM before it uses the RTM instructions (XBEGIN, XEND, XABORT). These instructions will generate a #UD exception when used on a processor that does not support RTM. The XTEST instruction also requires a CPUID check to ensure either HLE or RTM is supported, else it will also generate a #UD exception. The CPUID information may be cached in some variable to avoid checking for CPUID repeatedly.

With HLE, if the eliding processor itself reads the value of the lock in the critical section, the value returned will appear as if the processor had acquired the lock; the read will return the non-elided value. This behavior makes an HLE execution functionally equivalent to an execution without the HLE prefixes.

The RTM interface allows programmers to write more complex synchronization algorithms and to control the retry policies following transactional aborts. The preferred way is to use the RTM-based locking implementation as a wrapper with multiple code paths within; one path exercising the RTM-based lock and the other exercising the non-RTM based lock (See Section 16.3.4). This typically does not require changes to the non-RTM based lock code. Performance may further be improved by using a try-once primitive, which allows the thread to re-attempt lock elision after the lock becomes free.

Since the RTM instructions do not have any explicit lock associated with the instructions, software using these instructions for lock elision must test the lock within the transactional region, and only if free should it continue executing transactionally. Further, the software may also define a policy to retry if the lock is not free.

In a subtle difference with HLE, if the code within the RTM-based critical section reads the lock, it will appear as if it is free and not acquired. So library functions used to return the value of locks must abort the transactional execution and return the value when executed non-transactionally (See Section 16.3.9). This situation does not exist with HLE because the HLE instructions have an explicit lock address associated with them and the hardware ensures the right value is returned.

User/Source Coding Rule 32. *When using RTM for implementing lock elision, always test for lock inside the transactional region.*

Tuning Suggestion 14. *Don't use an RTM wrapper if the lock variable is not readable in the wrapper.*

16.3.4 An example wrapper for lock elision using RTM

This section describes how to write a wrapper to implement lock elision using RTM instructions. The idea is to take the conventional lock implementation (without elision), add a wrapper around it, and then add a new path within the wrapper to implement elision. Thus, the wrapper provides separate code paths for the elided path and the non-elided paths. The non-elided lock-acquire path is executed only if the elided path was unsuccessful. Further, such an approach allows the non-elided path to remain unchanged. Such an approach works well for wide variety of locks, including ticket locks and read-write locks.

An example code sequence is shown in Example 16-3 (See Section 16.7 for a description of the intrinsics used).

Example 16-3. Exemplary Wrapper Using RTM for Lock/Unlock Primitives

```

void rtm_wrapped_lock(lock) {
    if (_xbegin() == _XBEGIN_STARTED) {
        if (lock is free)
            /* add lock to the read-set */
            return; /* Execute transactionally */
        _xabort(0xff);
        /* 0xff means the lock was not free */
    }
    /* come here following the transactional abort */
    original_locking_code(lock);
}

void rtm_wrapped_unlock(lock) {
    /* If lock is free, assume that the lock was elided */
    if (lock is free)
        _xend(); /* commit */
    else
        original_unlocking_code(lock);
}

```

In Example 16-3, `_xabort()` terminates the transactional execution if the lock was not free. One can use `_xend()` to achieve the same effect. However, the profiling tool can easily recognize the `_xabort()` operation along with the 0xff abort code (which is a software convention) and determine that this is the case where the lock was not available. If the `_xend()` were used, the profiling tool would be unable to distinguish this case from the case where a lock was successfully elided.

The example above is a simplified version showing a basic policy of retrying only once and not distinguishing between various causes for transactional aborts. A more sophisticated implementation may add heuristics to determine whether to try elision on a per-lock basis based on information about the causes of transactional aborts. It may also have code to switch back to re-attempting lock elision after blocking if the lock was not free. This may require small changes to the underlying synchronization library.

Sometimes programming errors can lead to a thread releasing a lock that is already free. This error may not manifest itself immediately. However, when such a lock release function is replaced with an RTM-enabled library using the wrapper described above, an XEND instruction will execute outside a transactional region. In this case, the hardware will signal a #GP exception. It is generally a good idea to fix the error in the original application. Alternatively, if the software wants to retain the original erroneous code path, then a XTEST can be used to guard the XEND.

16.3.5 Guidelines for the RTM fallback handler

The fallback handler for RTM provides the code path that is executed if the RTM-based transactional execution is unsuccessful. Since the Intel TSX architecture specification does not provide any guarantee that a transactional execution will ever succeed, the RTM fallback handler must have the capability to ensure forward progress; it should not simply keep retrying the transactional execution.

Tuning Suggestion 15. *When RTM is used for lock elision, forward progress is easily ensured by acquiring the lock.*

If the fallback handler explicitly acquires the lock, then all other transactionally executing threads eliding the same lock will abort and the execution serializes on the lock. This is achieved by ensuring that the lock is in the transactional region's read-set.

Software can use the abort information provided in the EAX register to develop heuristics as to when to retry the transactional execution and when to fallback and explicitly acquire the lock. For example, if the `_XABORT_RETRY` bit is clear, then retrying the transactional execution is likely to result in another abort. The fallback handler should distinguish this situation from cases where the lock was not free (for example, the `_XABORT_EXPLICIT` bit is set but the `_XABORT_CODE()`¹ returns a 0xff identifying the condition as a "lock busy" condition). In those cases, the fallback handler should eventually retry after waiting.

Performance may also be improved by retrying (after a delay) if the abort cause was a data conflict (`_XABORT_CONFLICT`) because such conditions are often transient. Such retries however should be limited and must not continually retry.

A very small number of retries for capacity aborts (`_XABORT_CAPACITY`) can be beneficial on configurations with Hyper Threading enabled. The L1 cache is a shared resource between HT threads and one thread may push data out of the other. On retry there is a reasonable chance to succeed. This requires ignoring the `_XABORT_RETRY` bit in the status code for this case. The `_XABORT_RETRY` bit should not be ignored for any other reason.

Generally on higher core count and multi-socket systems the number of retries should be increased.

In general, if the lock was not free, then the fallback handler should wait until the lock is free prior to retrying the transactional execution. This helps to avoid situations where the execution may persistently stay in a non-transactional execution without lock elision. This can happen because the fallback handler never had an opportunity to try a transactional execution while the lock was free (See Section 16.3.8).

User/Source Coding Rule 33. *RTM abort handlers must provide a valid tested non transactional fallback path.*

Tuning Suggestion 16. *Lock Busy retries should wait for the lock to become free again.*

16.3.6 Implementing Elision-Friendly Locks using Intel® TSX

This section discusses strategies for implementing elision friendly versions of common locking algorithms using the Intel TSX instructions. Similar approaches can be adopted for algorithms not covered in this section.

16.3.6.1 Implementing a Simple Spinlock using HLE

A spinlock is a simple yet very common locking algorithm. In this algorithm, a thread first checks to see if the lock is free and then attempts to acquire the lock through a LOCK-prefixed instruction. If not, the thread spins (using a read operation that typically completes from the local data cache holding the lock value) on the lock waiting for it to become free.

For this example, assume the lock is free when its value is zero, and held by some thread otherwise. The lock is released through a regular store instruction.

Example 16-4 uses the gcc 4.8+ **atomic intrinsics** which are similar to the C11 standard. The description here follows the recommended approach to implement a spin lock using gcc 4.8+ intrinsics. To enable HLE for this spin lock, the only change required would be the addition of the `__ATOMIC_HLE_ACQUIRE` and `__ATOMIC_HLE_RELEASE` flags. The rest of the code is the same as without using HLE.

1. `_XABORT_CODE` accesses the xabort status in the RTM abort code

Example 16-4. Spin Lock Example Using HLE in GCC 4.8 and Later

```

#include <immintrin.h> /* For _mm_pause() */
/* Lock initialized with 0 initially */
void hle_spin_lock(int *lock)
{
    while (__atomic_exchange_n(lock, 1, __ATOMIC_ACQUIRE|__ATOMIC_HLE_ACQUIRE) != 0)
    { int val;
      /* Wait for lock to become free again before retrying. */
      do {
          _mm_pause(); /* Abort speculation */
          __atomic_load_n(lock, &val, __ATOMIC_CONSUME);
      } while (val == 1);
    }
}

void hle_spin_unlock(int *lock)
{
    __atomic_clear(lock, __ATOMIC_RELEASE|__ATOMIC_HLE_RELEASE);
}

```

The following shows the same example using intrinsics for the Windows C/C++ compilers (Microsoft Visual Studio 2012 and Intel C++ Compiler 17.0).

Example 16-5. Spin Lock Example Using HLE in Intel and Microsoft Compiler Intrinsic

```

#include <intrin.h> /* For _mm_pause() */
#include <immintrin.h> /* For HLE intrinsics */
/* Lock initialized with 0 initially */
void hle_spin_lock(int *lock)
{
    while (!_InterlockedCompareExchange_HLEAcquire(&lock, 1, 0)){
        /* Wait for lock to become free again before retrying speculation */
        do {
            _mm_pause(); /* Abort speculation */
            /* prevent compiler instruction reordering and wait-loop skipping,
             no additional fence instructions are generated on IA */
            _ReadWriteBarrier();
        } while (lock == 1);
    }
}

void hle_spin_unlock(int *lock)
{
    _Store_HLERelease (lock, 0);
}

```

See Section 16.7 for an assembler implementation of an HLE spinlock.

16.3.6.2 Implementing Reader-Writer Locks using Intel TSX

Reader-Writer locks are common where the critical sections are mostly read-only. Such locks can avoid serializing access to the critical section for readers; however, they still require an atomic operation on a shared location (often through a LOCK prefixed XADD or CMPXCHG) and require communication among the multiple readers. Note that lock elision essentially makes all locks behave as reader-writer locks - except that, with lock elision readers and non-conflicting writers can proceed concurrently without communication.

RTM can be used to elide reader-writer locks through a wrapper approach as discussed earlier. The only difference being that, with reader-writer locks, the lock algorithm normally checks both the reader and the writer states to determine that the lock is free. When it is possible to place the reader and writer locking state on different cache lines, it is also possible to let transactional and non-transactional readers execute in parallel. The readers only need to check the writer state being free.

With HLE, the code path for the elided version and non-elided version should remain the same. Some reader-writer lock implementations use a lock to protect the reader/writer state instead of the actual critical section. In this case, the lock first needs to be changed to have a fast path with a single atomic operation. Beyond this, the path should not change the cache line with the lock variable. This can be done by combining the reader and writer counts into a single field, and then checking/updating it atomically with a LOCK- prefixed XADD or CMPXCHG instruction for the lock acquire and lock release functions. The HLE prefixes - XACQUIRE and XRELEASE - are placed on these LOCK-prefixed operations. Interestingly, this approach also improves the performance of reader-writer locks even without using Intel TSX. Alternatively, using an RTM wrapper can avoid changing lock structure since you can have different lock acquire paths for elided and non-elided versions in the synchronization library.

Tuning Suggestion 17. For Read/Write locks elide the complete lock operation, not the building block locks.

16.3.6.3 Implementing Ticket Locks using Intel® TSX

Ticket locks are another common algorithm. A ticket lock is a variant of a spinlock where instead of spinning on a shared location and then racing to acquire the lock when the lock is free, threads use tickets to determine which thread can enter the critical section.

RTM can be used to elide ticket locks through a wrapper approach as discussed earlier (See Section 16.3.4).

Some ticket lock implementations assume an increasing ticket value and such locks do not meet HLE's requirement that the value of the lock following the lock release be the same as the value prior to the lock acquire.

Tuning Suggestion 18. Use RTM to elide ticket locks.

16.3.6.4 Implementing Queue-Based Locks using Intel® TSX

In general, the idea of lock elision requires multiple threads to concurrently enter and try to commit a common critical section. The idea of fair locks requires threads to enter and release the critical section in a first-come first-served order. The two ideas may sometimes appear at odds, but the general objective is usually more flexible.

Queue-based locks are a form of fair locks where the threads construct a queue of lock requests. This includes different forms of ticket locks.

In some implementations the queue is formed through an initial LOCK-prefixed operation. For such implementations, the HLE XACQUIRE prefix can be added to this operation to enable lock elision. In the absence of any transactional aborts, the queue remains empty following the lock release. However, if a transactional abort occurs and the aborting thread acquires the lock explicitly (thus forming a queue), subsequent threads will add themselves to the queue, and when the lock is released, only a single thread will attempt lock elision as the other threads are not at the front of the queue. Further, if another thread arrives and adds itself to the queue, this may cause the transactionally executing thread to abort, and the execution remains in a non-eliding phase until the queue is drained.

This scenario only occurs with lock implementations that attempt lock elision as part of the queuing process. It does not apply to implementations that construct a queue only after an initial atomic operation, like an adaptive spinning-sleeping lock that elides the spinning phase but only queues for waiting after initial spinning failed. Such a problem also doesn't exist for implementations that use wrappers (such as those using RTM). In these implementations, the thread does not attempt lock elision as part of the queuing process.

Tuning Suggestion 19. Use an RTM wrapper for locks that implement queuing as part of the initial atomic operation.

16.3.7 Eliding Application-Specific Meta-Locks using Intel® TSX

Some applications build their own locks, called meta-locks, using an underlying synchronization library. In this approach, the application uses a lock from the underlying synchronization library to protect the data of the meta-lock. It then updates the data and releases the lock. If you recall, a similar approach was taken for the reader-writer lock implementation discussed in Section 16.3.6.2.

The application executes the critical section while holding the meta-lock, and then uses a lock from the underlying synchronization library to protect the meta-lock while it is being released. In this sequence, eliding the lock from the underlying synchronization library isn't useful; the goal should be to elide the meta-lock itself and transactionally execute the application code itself instead of the code in the synchronization library. A profiling tool can be used to identify such critical sections. An RTM wrapper (similar to one discussed in Section 16.3.4) can be used to avoid the meta-lock during lock elision.

For illustration, assume the following as an example of a meta-lock implementation.

Example 16-6. A Meta Lock Example

```
void meta_lock(Metalock *metalock) {
    __lock(metalock->lock);
    /* modify meta lock state for lock */
    unlock(metalock->lock);
}

void meta_unlock(Metalock *metalock) {
    lock(metalock->lock);
    /* drop metalock state */
    unlock(metalock->lock);
}

meta_lock(metalock);
/* critical section */
meta_unlock(metalock);
```

The above example can be transformed into the following code.

Example 16-7. A Meta Lock Example Using RTM

```

void rtm_meta_lock(Metalock *metalock) {
    if (_xbegin() == _XBEGIN_STARTED)
        if (meta_state_is_all_free(metalock))
            return;
        _xabort(0xff);
    }
    meta_lock(metalock);
}
void rtm_meta_unlock(Metalock *metalock) {
    if (meta_state_is_all_free(metalock))
        _xend();
    else
        meta_unlock(metalock);
}

rtm_meta_lock(metalock);
/* critical section */
rtm_meta_unlock(metalock);

```

Tuning Suggestion 20. For meta-locking elide the full outer lock, not the building block locks.

16.3.8 Avoiding Persistent Non-Elided Execution

A transactional abort eventually results in execution transitioning to a non-transactional state without lock elision. This ensures forward progress. However, under certain conditions and with some lock acquire algorithms, threads may remain in a persistent non-transactional execution without attempting lock elision for an extended duration. This will limit performance opportunities.

To understand such situations, consider the following example with a simple spin lock implementation using HLE (a similar scenario can also exist with RTM). The lock value of zero means the lock is free and a value of one means it is acquired by some thread.

The HLE-enabled lock-acquire sequence can be written as shown in Example 16-8.

Example 16-8. HLE-enabled Lock-Acquire/ Lock-Release Sequence

```

mov eax,$1
Retry:
XACQUIRE; xchg LockWord,eax
cmp eax,$0 # Was zero so lock was acquired successfully
jz Locked
SpinWait:
cmp LockWord, $1
jz SpinWait# Still one
jmp Retry# It's free, try to claim
Locked:

XRELEASE; mov LockWord,$0

```

If a thread is unable to perform lock elision, then it acquires the lock without elision. Assume another thread arrives to acquire the lock. It executes the “XACQUIRE; xchg lockWord, eax” instruction, elides the lock operation on the lock, and enters transactional execution. However the lock at this point was held by another thread causing this thread to enter the SpinWait loop while still executing transactionally. This spin occurs during transactional execution because hardware does not have the notion of a critical section lock - it only sees the instruction to implement the atomic operation on the lock variable. The hardware doesn't have the semantic knowledge that the lock was not free.

Now, if the thread that held the lock releases it, the write operation to the lock will cause the current transactional thread spinning on the location to transactionally abort (because of the conflict between the lock release operation and the read loop of the lock by the transactional thread). Once it has aborted, the thread will restart execution without lock elision. It is easy to see how this extends to all other threads - they spin transactionally but end up executing non-transactionally and without lock elision when they actually find the lock free. This will continue until no other threads are trying to acquire the lock. The threads have thus entered a persistent non-elided execution.

A simple fix for this includes using the pause instruction (which causes an abort) as part of the spin-wait loop. This is also the recommended approach to waiting on a lock to be released, even without Intel TSX. The pause instruction will force the spin-wait loop to occur non-transactionally, thus allowing the threads to try lock elision when the lock is released.

Example 16-9. A Spin Wait Example Using HLE

```

    mov eax,$1
Retry:
    XACQUIRE; xchg LockWord,eax
    cmp eax,$0# Was zero so we got it
    jz Locked
SpinWait:
    pause
    cmp LockWord, $1
    jz SpinWait# Still one
    jmp Retry# It's free, try to claim
Locked:

```

Tuning Suggestion 21. Always include a pause instruction in the wait loop of a HLE spinlock.

16.3.9 Reading the Value of an Elided Lock in RTM-based libraries

Some synchronization libraries provide interfaces that read the value of a lock. Libraries implementing lock elision using RTM may be unable to reliably determine if the lock variable has been acquired by the thread performing the elision since the lock was only read but not written to inside the library.

Sometimes the library interface may be as simple as a test to check whether a lock is acquired thus providing a sanity check to the software. To ensure the correct value is provided to the function using an RTM-based library, the transactional execution must be aborted and the lock explicitly acquired. This can be achieved by forcing an abort through the XABORT instruction (using `_xabort(0xfe)`). The `0xfe` code can be used by the fallback handler to determine this situation and aid in optimizations in eliminating such a read. Alternatively, the `_xtest()` intrinsic can be used avoid unnecessary transactional aborts:

```
assert(is_locked(my_lock)) => assert(_xtest() || is_locked(my_lock))
```

A better primitive for an elided synchronization library would combine both - the lock being acquired or a lock elision in progress. For example:

```
bool is_atomic(lock) { return _xtest() || is_locked(lock); }
```

At other times, the lock variable may be read as part of a function with assumptions about behavior. An example is the **try-lock** interface to acquire a lock where a thread makes a single attempt to acquire the lock and returns a value indicating whether the lock was free or not. This is in contrast to a spin lock that continues to spin trying to acquire the lock. In general, this isn't a problem. But sometimes, software may make implicit assumptions about the actual value returned by a nested try-lock. With an RTM-based implementation, the value returned will be that of a free lock since the lock was elided. If software is making such implicit assumptions about the value, then the synchronization library can force a transactional abort through the XABORT instruction (using `_xabort(0xfd)`). This will however cause unnecessary aborts in some programs. Such implicit programming assumptions are not recommended. As such implicit programming assumptions are rare, it is recommended to not abort in the synchronization library in trylock.

16.3.10 Intermixing HLE and RTM

HLE and RTM provide two alternative software interfaces to a common transactional execution capability. The behavior when HLE and RTM are nested together-HLE inside RTM or RTM inside HLE-is implementation specific. For the first implementation of the 4th generation Intel Core Processor, intermixing causes

a transactional abort. This behavior may change in subsequent processor implementations but the semantics of a transactional commit will be maintained.

In general, applications should avoid intermixing HLE and RTM as they are essentially achieving the end purpose of lock elision but through different software interfaces. However, library functions implementing lock elision may be unaware of the calling function and whether the calling function is invoking the library function while eliding locks using RTM or HLE.

Software can handle such conditions by using the `_xtest()` operation. For example, the library may check if it was invoked within a transactional region and if the lock is free. If the call was within a transactional region, the library may avoid starting a new transactional region. If the lock was not free, the library may return an indication through the `_xabort(0xff)` function. This does require the function that will be invoked on a release to recognize that the acquire operation was skipped.

Example 16-10 shows a conceptual sequence.

Example 16-10. A Conceptual Example of Intermixed HLE and RTM

```
// Lock Acquire sequence
// Use a function local or per-thread location
bool lock_in_transactional_region = false;
if (_xtest() && my lock is free) { /* Already in a transactional region*/
    lock_in_transactional_region = true;
} else {
    // acquire lock if free, else abort
}

// the lock release sequence
if (!lock_in_transactional_region) {
    // release lock
}
```

16.4 USING THE PERFORMANCE MONITORING SUPPORT FOR INTEL® TSX

Application tuning using Intel TSX relies on performance counter-based profiling to understand transactional execution behavior and the causes of transactional aborts. Achieving good performance with Intel TSX often requires some tuning based on data from a profiling tool to minimize aborts. Using the performance counters is often preferable to instrumenting the application as it is usually less intrusive and easier. Chapter 19 of the *Intel® 64 and IA-32 Architectures Software Developer's Manual, Volume 3B* provides information about performance monitoring.

In general, profiling can impact transactional execution as any profiling tool generates periodic interrupts to collect information, and the interrupt will cause a transactional abort. Hence, any profiling should try to minimize the impact of this in analysis. This is not an issue if one is profiling only transactional aborts.

Program startup tends to have a large number of events that occur only once. When profiling complex programs, skipping over the startup phase can significantly reduce any noise introduced by these events.

Profilers that support TSX tuning include Linux perf, Intel Performance Counter Monitor, and Intel VTune. See <http://www.intel.com/software/tsx> for references.

16.4.1 Measuring Transactional Success

The first step should be to measure the transactional success in an application. This is done with the Unhalted_Core_Cycles event programmed in three separate configurations with three counters:

1. Use the fixed cycles counter (IA32_FIXED_CTR0) to measure FixedCyclesCounter.
2. Configure IA32_PERFVTSEL2 with the IN_TX and IN_TXCP filters set to measure CyclesInTxCP in IA32_PMC2.
3. Configure another MSR IA32_PERFVTSELx (x= 0, 1, 3) with IN_TX filter to measure CyclesInTxOnly on the corresponding counter.

These cycle measurements should be set up to count and not sample frequently; sampling may cause additional transactional aborts. With these three values the total cycles, cycles spent in transactional execution, and cycles spent in transactional regions that eventually aborted can be computed:

```
CyclesTotal = FixedCycleCounter
%CyclesTransactionalAborted = ((CyclesInTxOnly - CyclesInTxCP) / CyclesTotal) * 100.0
%CyclesTransactional = (CyclesInTx / CyclesTotal) * 100.0
%CyclesNonTransactional = 100.0 - %CyclesTransactional
```

If CyclesTransactional is near zero then the application is either not using lock-based synchronization or not using a synchronization library enabled for lock elision through the Intel TSX instructions. In the latter case, the programmer should use an Intel TSX-enabled synchronization library (See Section 16.3).

If CyclesTransactionalAborted is small relative to CyclesTransactional, then the transactional success rate is high and additional tuning is not required.

If the CyclesTransactionalAborted is almost the same as CyclesTransactional (but not very small), then most transactional regions are aborting and lock elision is not going to be beneficial. The next step would be to identify the causes for transactional aborts and reduce them (See Section 16.2.4).

16.4.2 Finding locks to elide and verifying all locks are elided.

This step is useful if the cycles spent in transactional execution is low. This may be because few locks are being elided. The MEM_UOPS_RETIRED.LOCK_LOADS event should be counted and compared to the RTM_RETIRED.START or HLE_RETIRED.START events. If the number of lock loads is significantly higher than the number of transactional regions started, then one can usually assume that not all locks are marked for lock elision. The PEBS version of MEM_UOPS_RETIRED.LOCK_LOADS can be sampled to identify the missing locks. However, this technique isn't effective in immediately detecting missed opportunities with meta-locking (See Section 16.3.7). Additionally, a profile on the call graph of the MEM_UOPS_RETIRED.LOCK_LOADS event often identifies the high level synchronization library that needs to be TSX-enabled to allow transactional execution of the application level critical sections.

16.4.3 Sampling Transactional Aborts

The hardware implementation defines PEBS precise events to sample transactional aborts - HLE_RETIRED.ABORTED for HLE and RTM_RETIRED.ABORTED for RTM. This allows programmers to perform precise profiling of all transactional aborts in the execution. The test should be run with PEBS enabled and sampled to identify the code location where the transactional aborts are occurring. The PEBS handler (a part of the profiling tool) uses the EventingIP field in the PEBS record to report the correct code location of the transactional aborts.

As a next step, the most common transactional aborts should be examined and addressed. Sampling transactional aborts does not cause any additional aborts.

16.4.4 Classifying Aborts using a Profiling Tool

The PEBS record generated as a result of profiling transactional aborts contains additional information on the cause of the transactional abort in the TX Abort Information field. The lower 32 bits of the TX Abort

Information, called `Cycles_Last_TX`, also provides the cycles spent in the last transactional region prior to the abort. This approximately captures the cost of a transactional abort.

$$\text{RelativeCostOfAbortForIP} = \text{SUM}(\text{Cycles_Last_TX_For_IP})$$

Not all transactional aborts are equal - some don't contribute to performance degradation while the more expensive ones can have significant impact. The programmer can use this information to decide which transactional aborts to focus on first.

For more details on the PEBS record see the *Intel® 64 and IA-32 Architectures Software Developer's Manual, Volume 3B* Section 18.10.5.1

The profiling tool should display the abort cost to the user to classify the abort.

Tuning Suggestion 22. *The aborts with the highest cost should be examined first.*

Tuning Suggestion 23. *The TX Abort Information has additional information about the transactional abort.*

If the PEBS record **Instruction_Abort** bit (bit 34) is set, then the cause of the transactional abort can be directly associated with an instruction. For these aborts, the PEBS record captures the instruction address that was the source of the transactional abort. Exceptions, like page faults (including those that would normally terminate the program and those that fault in the working set of the program at startup) also show up as in this category.

If the PEBS record **Non_Instruction_Abort** bit (bit 35) is set, then the abort may not have been caused by the instruction reported by the instruction address in the PEBS record. An example of such an abort is one due to a data conflict with other threads. In this case, the **Data_Conflict** bit (bit 37) is also set. Another example is when transactional aborts occur due to capacity limitations for transactional write- and read-sets. This is captured by the `Capacity_Write` (bit 38) and the `Capacity_Read` (bit 39) fields.

Abort due to data conflicts may occur at arbitrary instructions within the transactional region. Hence it is useful to concentrate on conflict causes in the whole critical section. Instead of relying on the **EventingIP** reported by PEBS for the abort, one should focus on the return IP (IP of the abort code) in conjunction with the call graphs. The return IP typically points into the synchronization library, unless the lock is inlined. The caller identifies the critical section.

For capacity it can be also useful to concentrate on the whole critical section (profiling for `ReturnIP`) as the whole critical section needs to be changed to access less memory.

Tuning Suggestion 24. *Instruction aborts should be analyzed early, but only when they are costly and happen after program startup.*

Tuning Suggestion 25. *For data conflicts or capacity aborts, concentrate on the whole critical section, not just the instruction address reported at the time of the abort.*

Tuning Suggestion 26. *The profiler should support displaying the `ReturnIP` with callgraph for non-Instruction abort events, but display the `EventingRIP` for instruction abort events.*

Tuning Suggestion 27. *The PEBS TX Abort Information bits should be all displayed by the profiling tool.*

16.4.5 XABORT Arguments for RTM fallback handlers

If the `XABORT` instruction is used to abort an RTM-based transactional region, the instruction operand is passed to the fallback handler through the `EAX` register. This information is also provided by the PEBS-based profiling tool for RTM. A profiling tool can use this information to classify various `XABORT`-based transactional aborts. Defining a convention can be also helpful to write sophisticated fallback handlers.

The following table presents the convention used in this document:

Table 16-1. RTM Abort Status Definition

XABORT Code	Description
0xff	XABORT-based abort because lock was not free when tested (Section 16.3.4)
0xfe	XABORT-based abort because lock tested for the value of the elided lock (Section 16.3.9)
0xfd	XABORT-based abort during a nested try lock (Section 16.3.9)
0xfc: 0xf0	Reserved

Tuning Suggestion 28. *The profiling tool should display the abort code to the user for RTM aborts.*

16.4.6 Call Graphs for Transactional Aborts

The profiling tool generates interrupts to collect performance monitoring information. Such interrupts will cause transactional aborts. This means a profiling tool can only collect information after a transactional abort happened and the tool cannot see any function calls on the stack that only happened inside the transactional region; the only view of the call graph it has was the one at the beginning of the transactional execution. When a transactional abort is sampled with PEBS the RIP field contains the instruction pointer after the abort and the EventingIP field contains the instruction pointer within the transactional region at the time of the abort. The same also applies for sampling non-abort events, as any sampling causes transactional aborts.

Depending on the type of abort, it can be useful to profile for either ReturnIP or EventingIP. The stack callgraph collected by the profiling tool is always associated with the ReturnIP. When it is combined with the EventingIP, it may appear noncontiguous (the EventingIP may not be associated with the lowest level caller), as any function calls inside the transactional region are not included. When the function calls inside the transactional region are required to understand the abort cause, Last Branch Records (LBRs, See Section 25) or the SDE software emulation (see Section 16.4.8) can be used.

Tuning Suggestion 29. *The profiler should have options to display ReturnIP and EventingIP.*

Tuning Suggestion 30. *The stack callgraph is always associated with the ReturnIP and may appear noncontiguous with the EventingIP.*

Tuning Suggestion 31. *To see function calls inside the transactional region use LBRs or SDE.*

16.4.7 Last Branch Records and Transactional Aborts

The Last Branch Records (see section 17.4 in Volume 3 of the Intel Software Developer's Manual) provide information about transactional execution and aborts. Regular LBR usage is compatible with Intel TSX. Using LBRs can be useful to provide context inside the transaction, as the normal call graph is not visible. The lcall filter can be used to approximate a call graph. However, the LBR Call Graph Stack facility (Section 17.8 in Volume 3 of the Intel Software Developer's Manual) is not compatible with Intel TSX and may provide incomplete information.

Tuning Suggestion 32. *The PEBS profiling handler should support sampling LBRs on abort and report them to the user.*

16.4.8 Profiling and Testing Intel TSX Software using the Intel® SDE

The Intel® Software Development Emulator (Intel® SDE) tool [<http://software.intel.com/en-us/articles/intel-software-development-emulator>] enables software development for planned instruction set extensions before they appear in hardware. The tool can also be used for extended testing, debugging and analysis of software that take advantage of the new instructions.

Programmers can use a number of Intel SDE capabilities for functional testing, profiling and debugging programs using the Intel TSX instructions. The tool can provide insight into common transactional aborts and additional profiling capability not available directly on hardware. Programmers should not use the

tool to derive runtimes and absolute performance characteristics as those are a function of the inherently high overheads of the emulation the tool performs.

As described previously in Section 16.4.4, hardware reports the precise address of the instruction that caused an abort, unless the abort is due to either a data conflict or a resource limitation. The tool can provide the precise address of such an instruction and additional information about the instruction. The tool can further map this back to the application source code, providing the instruction address, source file names, line number, the call stacks, and the data address information the instruction was operating on. For victim transactions (aborted due to a conflict) the tool can also output source code locations where conflicting memory accesses have been executed.

This is achieved through the tool options:

```
-tsx -hle_enabled 1 -rtm-mode full -tsx_stats 1 -tsx_stats_call_stack 1
```

The fallback handler can use the contents of the EAX register to determine causes of aborts. The SDE tool can force a transactional abort with a specific EAX register value provided as an emulator parameter. This allows developers to test their fallback handler code with different EAX values. In this mode, every RTM-based transactional execution will immediately abort with the EAX register value being that provided as the parameter. This is quite effective in functionally testing for corner cases where a transactional execution aborts due to unresolved page faults or other similar operations (EAX = 0).

This is achieved through the tool options:

```
-tsx -rtm-mode abort -rtm_abort_reason EAX.
```

Intel SDE has instruction and memory access logging features which are useful for debugging capacity aborts. With the log data from Intel SDE, one can diagnose cache set population to determine if there is non-uniform cache set usage causing capacity overflows. A refined log data may be used to further diagnose the source of the aborts. The logging feature is enabled with the following options:

```
-tsx_debug_log 3 -tsx_log_inst 1 -tsx_log_file 1
```

Additionally Intel SDE allows to use a standard debugger (gdb and Microsoft Visual Studio) to perform functional debugging inside transactions.

16.4.9 HLE Specific Performance Monitoring Events

The Intel TSX Performance Events also include HLE-specific transactional abort conditions. These events track aborts due to causes listed in Section 16.2.4.4. These aborts often occur due to issues in synchronization library implementations. When a synchronization library is initially enabled for Intel TSX, it is useful to measure these events and improve the library until these counts are negligible.

TX_MEM.ABORT_HLE_STORE_TO_ELIDED_LOCK counts the number of transactional aborts due to a store operation without the XRELEASE prefix operating on an elided lock in the elision buffer. This is often because the library is missing the XRELEASE prefix on the lock release instruction.

TX_MEM.ABORT_ELISION_BUFFER_NOT_EMPTY counts the number of transactional aborts that occur because an XRELEASE prefixed lock release instruction that was committing the transactional execution finds the elision buffer with an elided lock. This typically occurs for code sequences where an XRELEASE occurs on a lock that wasn't elided and hence wasn't in the elision buffer.

TX_MEM.ABORT_HLE_ELISION_BUFFER_MISMATCH counts the number of transactional aborts because the XRELEASE lock does not satisfy the address and value requirements for elision in the elision buffer. This occurs for example if the value being written by the XRELEASE operation is different from the value that was read by the earlier XACQUIRE operation to the same lock.

TX_MEM.ABORT_HLE_ELISION_UNSUPPORTED_ALIGNMENT counts the number of transactional aborts if the lock in the elision buffer was accessed by a read in the transactional region but the read could not be serviced. This typically occurs if the access was not properly aligned, or had a partial overlap, or the read operation's linear address was different than the elided locks but the physical address was the same. These are fairly rare events.

16.4.10 Computing Useful Metrics for Intel® TSX

We now provide formulas to compute useful metrics with the performance events. While some of the counts are available as their own events, it can sometimes be useful to do a derivation with limited counters.

The following calculates the number of times a HLE or RTM transactional execution was started. This combines all nested regions into one region for counting purposes.

```
#HLE Regions Started: HLE_RETIRED.COMMIT + HLE_RETIRED.ABORTED
#RTM Regions Started: RTM_RETIRED.COMMIT + RTM_RETIRED.ABORTED
```

The following calculates the percentage of HLE or RTM transactional executions that aborted.

```
%AbortedHLE = 100.0 * (HLE_RETIRED.ABORTED/HLE_RETIRED.START)
%AbortedRTM = 100.0 * (RTM_RETIRED.ABORTED/RTM_RETIRED.START)
```

The following calculates the average number of cycles spent in a transactional region (See Section 16.4.1 for CyclesInTX computation).

```
AvgCyclesInHLE = CyclesInTX/HLE_RETIRED.START
AvgCyclesInRTM = CyclesInTX/RTM_RETIRED.START
AvgCyclesInTX=CyclesInTX/(HLE_RETIRED.START + RTM_RETIRED.START)
```

The following calculates the percentage of HLE or RTM transactional executions that aborted due to a data conflict.

```
%AbortedHLEDataConflict = TX_MEM.ABORT_CONFLICT/HLE_RETIRED.START;
%AbortedRTMDataConflict = TX_MEM.ABORT_CONFLICT / RTM_RETIRED.START;
%AbortedTXDataConclit= TX_MEM.ABORT_CONFLICT / (HLE_RETIRED.START+RTM_RETIRED.START);
```

The following calculates the number of HLE or RTM transactional executions that aborted due to limited resources for transactional stores.

```
%AbortedTXStoreResource = TX_MEM.ABORT_CAPACITY_WRITE
```

On processors based on the Broadwell and Skylake microarchitectures, the event "TX_MEM.ABORT_CAPACITY_WRITE" is replaced by TX_MEM.ABORT_CAPACITY that counts aborts due to either read or write.

The following calculates the total number of HLE or RTM transactional executions that aborted due to resource limitations. The distinction occurs because transactional reads that are evicted from the L1 data cache may not immediately cause an abort.

```
%AbortedHLEResource = HLE_RETIRED.ABORTED_MISC1 - TX_MEM.ABORT_CONFLICT
%AbortedRTMResource = RTM_RETIRED.ABORTED_MISC1 - TX_MEM.ABORT_CONFLICT
%AbortedTXResource = (HLE_RETIRED.ABORTED_MISC1+RTM_RETIRED.ABORTED_MISC5) - TX_EM.ABORT_CONFLICT
```

For HLE, HLE_RETIRED.ABORTED_MISC1 may include some additional contributions from the events discussed in Section 16.4.9. For accurate results the lock library should be tuned first to minimize them.

Note that HLE_RETIRED.ABORTED_MISC1 is also known with the more descriptive name HLE_RETIRED.ABORTED_MIEM. Similarly, RTM_RETIRED.ABORTED_MISC1 is also known as RTM_RETIRED.ABORTED_MEM.

16.5 PERFORMANCE GUIDELINES

The 4th generation Intel Core Processor is the first implementation that support Intel TSX. Transactional execution incurs some implementation dependent overheads. Performance will improve in subsequent microarchitecture generations. The first TSX implementation is oriented towards typical usage of critical sections in applications. As a result, these overheads are amortized and do not normally manifest themselves at an application level performance.

However, some guidelines are relevant to keep in mind:

Tuning Suggestion 33. *Intel TSX is designed for critical sections and thus the latency profiles of the XBEGIN/XEND instructions and XACQUIRE/XRELEASE prefixes are intended to match the LOCK prefixed instructions. These instructions should not be expected to have the latency of a regular load operation.*

There is an additional implementation-specific overhead associated with executing a transactional region. This consists of a mostly fixed cost in addition to a variable dynamic component. The overhead is

largely independent of the size and memory foot print of the critical section. The additional overhead is typically amortized and hidden behind the out-of-order execution of the microarchitecture. However, on the 4th generation Intel Core Processor implementation, certain sequences may appear to exacerbate the overhead. This is particularly true if the critical section is very small and appear in tight loops (for example something typically done in microbenchmarks). Realistic applications do not normally exhibit such behavior.

The overhead is amortized in larger critical sections but will be exposed in very small critical sections. One simple approach to reduce perceived overhead is to perform an access to the transactional cache lines early in the critical section

The overhead of commits is reduced with processors based on the Broadwell microarchitecture.

16.6 DEBUGGING GUIDELINES

Using Intel TSX to implement Lock Elision does not change application semantics - all architectural state updated during an aborted transactional execution is automatically discarded by the hardware. Care must be taken if new code paths are added to the application and these paths are exercised only under transactional execution (See Section 16.2.5).

However, lock elision may change the timing relationships among different threads since it requires communication among threads only when required by data conflicts. Hence, locks may appear to execute much faster than normal. Such timing changes may expose latent bugs in an application. Exposure of such latent bugs is not unique to Intel TSX and can be expected with every new hardware generation.

Code instrumentation is a common technique while debugging multi-threaded software. As is the case with debugging timing related issues, care must be taken when instrumenting code to not perturb timing significantly and to not cause unnecessary aborts. A per thread buffer can be utilized to trace execution and log events of interests. The RDTSC instruction can be used to obtain a timestamp. The buffer should be printed outside the critical section.

Transactional aborts discard all memory state updated within the transactional region. This information cannot be traced without instrumentation support. Issues within transactional regions will show up in a profiling tool as a transactional abort and the Last Branch Record information can be used to reconstruct the control flow. On processors that support Intel® Processor Trace, the trace log allows reconstructing the full trace of the control flow inside transactions. The trace also contains markers indicating transaction start, commit and abort.

The regular `assert()` function would cause a transactional abort and its output information would not make it out of the transactional region. When using the RTM instructions, the `assert` functionality can be enhanced to end the transactional execution, make side effects visible, and terminate the program through the `assert` function. For example:

```
assert(x) => if (!(x)) { while (_xtest()) _xend(); assert(0); }
```

16.7 COMMON INTRINSICS FOR INTEL® TSX

Recent assemblers (GNU binutils version 2.23, Microsoft Visual Studio 2012) include support for the Intel TSX instructions. On older tool chains it is possible to use the instructions as byte values.

16.7.1 RTM C Intrinsics

Recent C/C++ compilers (gcc 4.8, Microsoft Visual Studio 2012, Intel C++ Compiler 17.0) support RTM intrinsics in the `immintrin.h` header file. RTM is a new instruction set and should be only used after checking the RTM feature flag using the CPUID instruction (See Chapter 3 of the *Intel® 64 and IA-32 Architectures Software Developer's Manual, Volume 2A*).

`_xbegin()`

`_xbegin()` starts the transactional region and returns `_XBEGIN_STARTED` when in the transactional region, otherwise the abort code. It is important to check `_xbegin()` against `_XBEGIN_STARTED` which is not zero. Zero is a valid abort code. When the value is not `_XBEGIN_STARTED` the return code contains various status bits and an optional 8bit constant passed by `_xabort()`.

Valid status bits are:

- `_XABORT_EXPLICIT`: Abort caused by `_xabort()`. `_XABORT_CODE(status)` contains the value passed to `_xabort()`.
- `_XABORT_RETRY`: When this bit is set retrying the transactional region has a chance to commit. If not set retrying will likely not succeed.
- `_XABORT_CAPACITY`: The abort is related to a capacity overflow.
- `_XABORT_DEBUG`: The abort happened due to a debug trap.
- `_XABORT_NESTED`: The abort happened in a nested transaction.

`_xend()`

`_xend()` commits the transaction.

`_xtest()`

`_xtest()` returns true when the code is currently executing in a transaction. It can be also used with HLE.

`_xabort()`

`_xabort(constant)` aborts the current transaction. Constant can be only 8 bits. The constant is contained in the status code returned by `_xbegin()` and can be accessed with `_XABORT_CODE()` when the `_XABORT_EXPLICIT` flag is set. See Section 4.5 for a recommended convention.

On gcc 4.8 and later compilers, the `-mrtm` flag needs to be used to enable these intrinsics.

16.7.1.1 Emulated RTM intrinsics on older gcc compatible compilers

On older gcc compatible compilers that do not support the RTM intrinsics in `immintrin.h`, Example 16-11 shows the inline assembler equivalents that can be used.

Example 16-11. Emulated RTM intrinsic for Older GCC compilers

```

/* Not needed on newer toolchains that support this interface in immintrin.h */
#define _XBEGIN_STARTED      (~0u)
#define _XABORT_EXPLICIT    (1 << 0)
#define _XABORT_RETRY       (1 << 1)
#define _XABORT_CONFLICT    (1 << 2)
#define _XABORT_CAPACITY    (1 << 3)
#define _XABORT_DEBUG       (1 << 4)
#define _XABORT_NESTED      (1 << 5)
#define _XABORT_CODE(x)     (((x) >> 24) & 0xff)

#define __force_inline __attribute__((__always_inline__)) inline

```

Example 16-11. Emulated RTM intrinsic for Older GCC compilers (Contd.)

```

static __force_inline int _xbegin(void)
{
    int ret = _XBEGIN_STARTED;
    asm volatile(".byte 0xc7,0xf8 ; .long 0" : "+a" (ret) :: "memory");
    return ret;
}

static __force_inline void _xend(void)
{
    asm volatile(".byte 0x0f,0x01,0xd5" ::: "memory");
}

static __force_inline void _xabort(const unsigned int status)
{
    asm volatile(".byte 0xc6,0xf8,%P0" :: "i" (status) : "memory");
}

static __force_inline int _xtest(void)
{
    unsigned char out;
    asm volatile(".byte 0x0f,0x01,0xd6 ; setnz %0" : "=r" (out) :: "memory");
    return out;
}

```

16.7.2 HLE Intrinsics on gcc and Other Linux Compatible Compilers

On Linux and compatible systems HLE is implemented as an extension to gcc 4.8 and an older form of the C11 atomic primitives. HLE XACQUIRE can be used by setting the `__ATOMIC_HLE_ACQUIRE` flag to the memory model argument. HLE XRELEASE can be used with `__ATOMIC_HLE_RELEASE`.

For `__ATOMIC_HLE_ACQUIRE` the memory model must be `__ATOMIC_ACQUIRE` or stronger, for `__ATOMIC_HLE_RELEASE` `__ATOMIC_RELEASE` or stronger. For operations with a failure memory model (like `__atomic_compare_exchange_n`) the HLE flag is only supported on the non-failure memory model.

HLE is only supported on atomic operations that can be directly translated into IA atomic instructions. It is not supported with:

- 8 byte values on 32-bit targets.
- 16 byte values.
- Fetch-op or op-fetch other than add/sub when the result is accessed.
- `__atomic_store` and `__atomic_clear` only support `__ATOMIC_HLE_RELEASE`.

16.7.2.1 Generating HLE intrinsics with gcc4.8

Due to a compiler bug in some versions of gcc 4.8 the `-O2` or higher optimization level must be used to generate HLE hints using the atomic intrinsics.

16.7.2.2 C++11 atomic support

gcc 4.8 has support for the C++11 <atomic> header. The memory models defined there are extended with HLE flags similar to the C atomic interface. Two new flags `__memory_order_hle_acquire` and `__memory_order_hle_release` are defined. The constraints listed for the C atomic intrinsics apply. Example 16-12 shows a C++ example of an HLE intrinsic.

Example 16-12. C++ Example of HLE Intrinsic

```
#include <atomic>
#include <immintrin.h>
using namespace std;
atomic_flag lock;
for (;;) {
    if (!lock.test_and_test(memory_order_acquire|__memory_order_hle_acquire) {
        // Critical section with HLE lock elision
        lock.clear(memory_order_release|__memory_order_hle_release);
        break;
    } else {
        // Lock not acquired. Wait for lock and retry.
        while (lock.load()
            _mm_pause()); // abort transactional region on lock busy
    }
}
```

16.7.2.3 Emulating HLE intrinsics with older gcc-compatible compilers

For older compilers that do not support these intrinsics inline assembler can be used. For example to emulate `__atomic_exchange_n(&lock, 1, __ATOMIC_ACQUIRE|__ATOMIC_HLE_ACQUIRE)`, see Example 16-13.

Example 16-13. Emulated HLE Intrinsic with Older GCC compiler

```
#define XACQUIRE ".byte 0xf2;" /* For older assemblers not supporting XACQUIRE */
#define XRELEASE ".byte 0xf3;"
static inline int hle_acquire_xchg(int *lock, int val)
{
    asm volatile(XACQUIRE "xchg %0,%1" : "+r" (val), "+m" (*lock) :: "memory");
    return val;
}
static void hle_release_store(int *lock, int val)
{
    asm volatile(XRELEASE "mov %0,%1" : "r" (val), "+m" (*lock) :: "memory");
}
```

16.7.3 HLE intrinsics on Windows C/C++ compilers

Windows C/C++ compilers (Microsoft Visual Studio 2012 and Intel C++ Compiler 17.0) provide versions of certain atomic intrinsic with HLE prefixes; see Example 16-14.

Example 16-14. HLE Intrinsic Supported by Intel and Microsoft Compilers

Atomic compare-and-exchange operations:

```
long _InterlockedCompareExchange_HLEAcquire(long volatile *Destination, long Exchange, long Comparand);
__int64 _InterlockedCompareExchange64_HLEAcquire(__int64 volatile *Destination, __int64 Exchange, __int64
Comparand);
void * _InterlockedCompareExchangePointer_HLEAcquire(void * volatile *Destination, void * Exchange, void *
Comparand);
long _InterlockedCompareExchange_HLERelease(long volatile *Destination, long Exchange, long Comparand);
__int64 _InterlockedCompareExchange64_HLERelease(__int64 volatile *Destination, __int64 Exchange, __int64
Comparand);
void * _InterlockedCompareExchangePointer_HLERelease(void * volatile *Destination, void * Exchange, void *
Comparand);
```

Atomic addition:

```
long _InterlockedExchangeAdd_HLEAcquire(long volatile *Addend, long Value);
__int64 _InterlockedExchangeAdd64_HLEAcquire(__int64 volatile *Addend, __int64 Value);
long _InterlockedExchangeAdd_HLERelease(long volatile *Addend, long Value);
__int64 _InterlockedExchangeAdd64_HLERelease(__int64 volatile *Addend, __int64 Value);
```

Intrinsics for HLE prefixed stores:

```
void _Store_HLERelease(long volatile *Destination, long Value);
void _Store64_HLERelease(__int64 volatile *Destination, __int64 Value);
void _StorePointer_HLERelease(void * volatile *Destination, void * Value);
```

Please consult the compiler documentation for further information on these intrinsics.

17.1 OVERVIEW

Mobile computing allows computers to operate anywhere, anytime. Battery life is a key factor in delivering this benefit. Mobile applications require software optimization that considers both performance and power consumption. This chapter provides background on power saving techniques in mobile processors¹ and makes recommendations that developers can leverage to provide longer battery life.

A microprocessor consumes power while actively executing instructions and doing useful work. It also consumes power in inactive states (when halted). When a processor is active, its power consumption is referred to as active power. When a processor is halted, its power consumption is referred to as static power.

ACPI 3.0 (ACPI stands for Advanced Configuration and Power Interface) provides a standard that enables intelligent power management and consumption. It does this by allowing devices to be turned on when they are needed and by allowing control of processor speed (depending on application requirements). The standard defines a number of P-states to facilitate management of active power consumption; and several C-state types² to facilitate management of static power consumption.

Pentium M, Intel Core Solo, Intel Core Duo processors, and processors based on Intel Core microarchitecture implement features designed to enable the reduction of active power and static power consumption. These include:

- Enhanced Intel SpeedStep[®] Technology enables operating system (OS) to program a processor to transition to lower frequency and/or voltage levels while executing a workload.
- Support for various activity states (for example: Sleep states, ACPI C-states) to reduce static power consumption by turning off power to sub-systems in the processor.

Enhanced Intel SpeedStep Technology provides low-latency transitions between operating points that support P-state usages. In general, a high-numbered P-state operates at a lower frequency to reduce active power consumption. High-numbered C-state types correspond to more aggressive static power reduction. The trade-off is that transitions out of higher-numbered C-states have longer latency.

17.2 MOBILE USAGE SCENARIOS

In mobile usage models, heavy loads occur in bursts while working on battery power. Most productivity, web, and streaming workloads require modest performance investments. Enhanced Intel SpeedStep Technology provides an opportunity for an OS to implement policies that track the level of performance history and adapt the processor's frequency and voltage. If demand changes in the last 300 ms³, the technology allows the OS to optimize the target P-state by selecting the lowest possible frequency to meet demand.

-
1. For Intel[®] Centrino[®] mobile technology and Intel[®] Centrino[®] Duo mobile technology, only processor-related techniques are covered in this manual.
 2. ACPI 3.0 specification defines four C-state types, known as C0, C1, C2, C3. Microprocessors supporting the ACPI standard implement processor-specific states that map to each ACPI C-state type.
 3. This chapter uses numerical values representing time constants (300 ms, 100 ms, etc.) on power management decisions as examples to illustrate the order of magnitude or relative magnitude. Actual values vary by implementation and may vary between product releases from the same vendor.

Consider, for example, an application that changes processor utilization from 100% to a lower utilization and then jumps back to 100%. The diagram in Figure 17-1 shows how the OS changes processor frequency to accommodate demand and adapt power consumption. The interaction between the OS power management policy and performance history is described below.

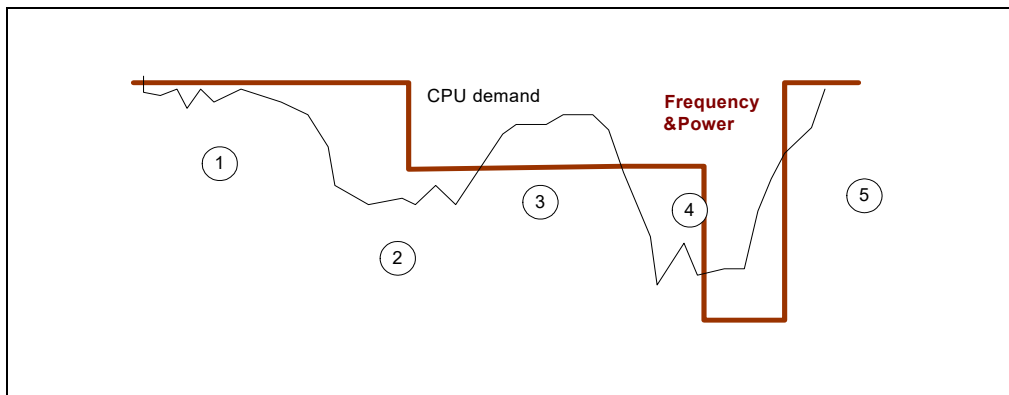

Figure 17-1. Performance History and State Transitions

1. Demand is high and the processor works at its highest possible frequency (P0).
2. Demand decreases, which the OS recognizes after some delay; the OS sets the processor to a lower frequency (P1).
3. The processor decreases frequency and processor utilization increases to the most effective level, 80-90% of the highest possible frequency. The same amount of work is performed at a lower frequency.
4. Demand decreases and the OS sets the processor to the lowest frequency, sometimes called Low Frequency Mode (LFM).
5. Demand increases and the OS restores the processor to the highest frequency.

17.2.1 Intelligent Energy Efficient Software

With recent advances in power technology and wide range of computing scenarios demanded by end users, intelligent balance between power consumption and performance becomes more and more important. Energy efficient software plays a key role in exploring the latest hardware power savings offered by current generation architecture. Poorly-written code can prevent a system from taking advantage of new hardware features and serving the dynamic needs of end users.

A mobile platform consists of various components such as a CPU, LCD, HDD, DVD, and chipsets, which individually contribute to the power drain of the notebook. Understanding the power contribution of each major component in the platform provides a better view on the total power usage, provides guidance on optimizing power consumption, and may help software to adjust dynamic balance of power budgets between some components.

The following are a few general guidelines for energy efficient software:

- Application should leverage modern OS facility to select appropriate operating frequency instead of setting processor frequency by itself. The latter is likely to have negative impact on both power consumption and performance.
- When your application is waiting for user input or another event to happen, let your application use services that are optimized to go to idle mode quickly. The idle behavior can have a big impact on power consumption. When an application knows it will be operating in a mostly idle context, reduce the frequency of application events that wake up the processor, avoid periodic polling, and reduce the number of services that are active in memory.
- Build context awareness into applications to extend battery life further and optimal user experience.

- Architect an awareness of power consumption and/or dynamic power policy into your application for contextual usages and optimal end user experiences. Specific detail may vary across OSes. For Microsoft Windows OS consult http://www.microsoft.com/whdc/system/pnppwr/powermgmt/PMpolicy_Windows.msp#.
- Characterize your application's power consumption. There are various techniques available to measure the power consumption of a platform:
 - Use hardware instrumentation such as Fluke NetDAQ*. This provides power measurements for each component such as CPU, HDD, and memory.
 - Use C-state residency counters. See Chapter 2, "Model-Specific Registers (MSRs)" of *Intel® 64 and IA-32 Architectures Software Developer's Manual, Volume 4*.
 - Study parameters such as CPU usage, kernel time, and time interrupt rate, to gain insight into the behavior of the software, which can then be related to platform power consumption if the hardware instrumentation is not available.

Section 17.5 provide some examples on how to relate performance with power consumption and techniques for optimizing software.

17.3 ACPI C-STATES

When computational demands are less than 100%, part of the time the processor is doing useful work and the rest of the time it is idle. For example, the processor could be waiting on an application time-out set by a Sleep() function, waiting for a web server response, or waiting for a user mouse click. Figure 17-2 illustrates the relationship between active and idle time.

When an application moves to a wait state, the OS issues a HLT instruction and the processor enters a halted state in which it waits for the next interrupt. The interrupt may be a periodic timer interrupt or an interrupt that signals an event.

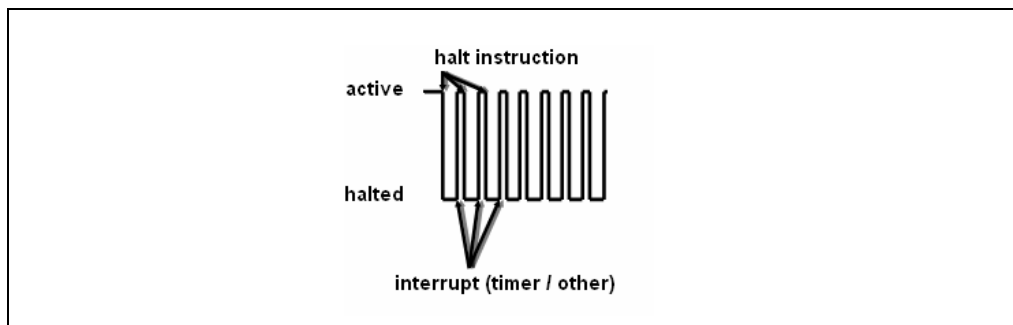

Figure 17-2. Active Time Versus Halted Time of a Processor

As shown in the illustration of Figure 17-2, the processor is in either active or idle (halted) state. ACPI defines four C-state types (C0, C1, C2 and C3). Processor-specific C states can be mapped to an ACPI C-state type via ACPI standard mechanisms. The C-state types are divided into two categories: active (C0), in which the processor consumes full power; and idle (C1-3), in which the processor is idle and may consume significantly less power.

The index of a C-state type designates the depth of sleep. Higher numbers indicate a deeper sleep state and lower power consumption. They also require more time to wake up (higher exit latency).

C-state types are described below:

- C0 — The processor is active and performing computations and executing instructions.
- C1 — This is the lowest-latency idle state, which has very low exit latency. In the C1 power state, the processor is able to maintain the context of the system caches.

- C2 — This level has improved power savings over the C1 state. The main improvements are provided at the platform level.
- C3 — This level provides greater power savings than C1 or C2. In C3, the processor stops clock generating and snooping activity. It also allows system memory to enter self-refresh mode.

The basic technique to implement OS power management policy to reduce static power consumption is by evaluating processor idle durations and initiating transitions to higher-numbered C-state types. This is similar to the technique of reducing active power consumption by evaluating processor utilization and initiating P-state transitions. The OS looks at history within a time window and then sets a target C-state type for the next time window, as illustrated in Figure 17-3:

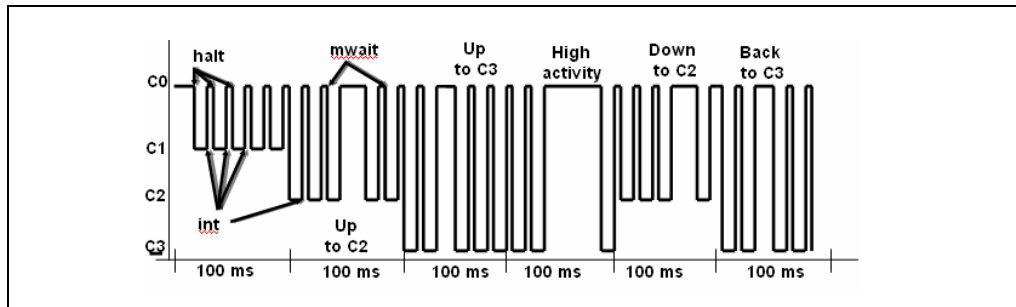

Figure 17-3. Application of C-states to Idle Time

Consider that a processor is in lowest frequency (LFM- low frequency mode) and utilization is low. During the first time slice window (Figure 17-3 shows an example that uses 100 ms time slice for C-state decisions), processor utilization is low and the OS decides to go to C2 for the next time slice. After the second time slice, processor utilization is still low and the OS decides to go into C3.

17.3.1 Processor-Specific C4 and Deep C4 States

The Pentium M, Intel Core Solo, Intel Core Duo processors, and processors based on Intel Core microarchitecture¹ provide additional processor-specific C-states (and associated sub C-states) that can be mapped to ACPI C3 state type. The processor-specific C states and sub C-states are accessible using MWAIT extensions and can be discovered using CPUID. One of the processor-specific state to reduce static power consumption is referred to as C4 state. C4 provides power savings in the following manner:

- The voltage of the processor is reduced to the lowest possible level that still allows the L2 cache to maintain its state.
- In an Intel Core Solo, Intel Core Duo processor or a processor based on Intel Core microarchitecture, after staying in C4 for an extended time, the processor may enter into a Deep C4 state to save additional static power.

The processor reduces voltage to the minimum level required to safely maintain processor context. Although exiting from a deep C4 state may require warming the cache, the performance penalty may be low enough such that the benefit of longer battery life outweighs the latency of the deep C4 state.

17.3.2 Processor-Specific Deep C-States and Intel® Turbo Boost Technology

Processors based on Nehalem microarchitecture implement several processor-specific C-states.

1. Pentium M processor can be detected by CPUID signature with family 6, model 9 or 13; Intel Core Solo and Intel Core Duo processor has CPUID signature with family 6, model 14; processors based on Intel Core microarchitecture has CPUID signature with family 6, model 15.

Table 17-1. ACPI C-State Type Mappings to Processor Specific C-State for Mobile Processors Based on Nehalem Microarchitecture

ACPI C-State Type	Processor-Specific C-State
C0	C0
C1	C1
C2	C3
C3	C7

The processor-specific deep C-states are implementation dependent. Generally, the low power C-states (higher numbered C-states) have higher exit latencies. For example, when the cores are already in C7, the last level cache (L3) is flushed. The processor support auto-demotion of OS request to deep C-states (C3/C7) and demote to C1/C3 state to support flexible power-performance settings.

In addition to low-power, deep C-states, Intel Turbo Boost Technology can opportunistically boost performance in normal state (C0) by mapping p1 state to the processor's qualified high-frequency mode operation. Headroom in the system's TDP can be converted to an even higher frequency than P1 state target. When the operating system requests P0 state, the processor sets core frequencies between P1 to P0 range. A P0 state with only one core busy, achieves the maximum possible Intel Turbo Boost Technology frequency, whereas when the processor is running two to four cores the frequency is constrained by processor limitations. Under normal conditions the frequency does not go below P1, even when all cores are running.

17.3.3 Processor-Specific Deep C-States for Sandy Bridge Microarchitecture

Processors based on Sandy Bridge microarchitecture implement several processor-specific C-states.

Table 17-2. ACPI C-State Type Mappings to Processor Specific C-State of Sandy Bridge Microarchitecture

ACPI C-State Type	Processor-Specific C-State
C0	C0
C1	C1
C2	C3
C3	C6/C7

The microarchitectural behavior of processor-specific deep C-states are implementation dependent. The following summarizes some of their key power-saving and intelligent responsive characteristics:

- For mobile platforms, while the cores are already in C7, the last level cache (L3) is flushed.
- Auto-demotion: The processor can demote OS requests to a target C-state (core C6/C7 or C3 state) to a numerically lower C-state (core C3 or C1 state) in the following cases:
 - When history indicates that C6/C7 or C3 states are less energy efficient than C3 or C1 states.
 - When history indicates that a deeper sleep state may impact performance.
 - Energy inefficiency or performance degradation can occur due to the deeper C-state transition overhead occurring too frequently. Sandy Bridge microarchitecture has an enhanced algorithm that improves power gain from this feature.
- Un-demotion: An OS request to a deeper C-state can be demoted by auto-demotion, resulting in C1 or C3 states. After long residency in the demoted state, the hardware returns control back to the OS. The expectation is that in this case, the OS will repeat the deeper C-state request and hardware un-demotion will enter into the OS-requested deeper C state.

17.3.4 Intel® Turbo Boost Technology 2.0

Intel® Turbo Boost Technology 2.0 is a second generation enhancement of Intel® Turbo Boost Technology. The latter can opportunistically boost the processor core's frequency to a higher frequency above the qualified frequency depending on the TDP headroom.

The TDP of Intel Core processors based on Sandy Bridge microarchitecture include budgets for the processor core and processor graphic sub-system. Intel® Turbo Boost Technology 2.0 allows more opportunity to convert the thermal and power budget headroom to boost the processor core frequency and/or operating frequency of the processor graphic sub-system.

Energy consumption by the processor cores and/or by the processor graphic unit can be measured using a set of MSR interface¹. Operating system requirements to support Intel Turbo Boost Technology, to use hints to optimize performance and energy bias in turbo mode operation, are described in Chapter 15, "Power and Thermal Management" of *Intel® 64 and IA-32 Architectures Software Developer's Manual, Volume 3A*.

17.4 GUIDELINES FOR EXTENDING BATTERY LIFE

Follow the guidelines below to optimize to conserve battery life and adapt for mobile computing usage:

- Adopt a power management scheme to provide just-enough (not the highest) performance to achieve desired features or experiences.
- Avoid using spin loops.
- Reduce the amount of work the application performs while operating on a battery.
- Take advantage of hardware power conservation features using ACPI C3 state type and coordinate processor cores in the same physical processor.
- Implement transitions to and from system sleep states (S1-S4) correctly.
- Allow the processor to operate at a higher-numbered P-state (lower frequency but higher efficiency in performance-per-watt) when demand for processor performance is low.
- Allow the processor to enter higher-numbered ACPI C-state type (deeper, low-power states) when user demand for processor activity is infrequent.

17.4.1 Adjust Performance to Meet Quality of Features

When a system is battery powered, applications can extend battery life by reducing the performance or quality of features, turning off background activities, or both. Implementing such options in an application increases the processor idle time. Processor power consumption when idle is significantly lower than when active, resulting in longer battery life.

Example of techniques to use are:

- Reducing the quality/color depth/resolution of video and audio playback.
- Turning off automatic spell check and grammar correction.
- Turning off or reducing the frequency of logging activities.
- Consolidating disk operations over time to prevent unnecessary spin-up of the hard drive.
- Reducing the amount or quality of visual animations.
- Turning off, or significantly reducing file scanning or indexing activities.
- Postponing possible activities until AC power is present.

1. Generally, energy measurements and power management decisions based on these MSR interfaces should operate within the same processor family/model and refrain from extrapolating across different family/models or unsupported environmental conditions.

Performance/quality/battery life trade-offs may vary during a single session, which makes implementation more complex. An application may need to implement an option page to enable the user to optimize settings for user's needs (see Figure 17-4).

To be battery-power-aware, an application may use appropriate OS APIs. For Windows XP, these include:

- `GetSystemPowerStatus` — Retrieves system power information. This status indicates whether the system is running on AC or DC (battery) power, whether the battery is currently charging, and how much battery life remains.
- `GetActivePwrScheme` — Retrieves the active power scheme (current system power scheme) index. An application can use this API to ensure that system is running best power scheme. **Avoid Using Spin Loops.**

Spin loops are used to wait for short intervals of time or for synchronization. The main advantage of a spin loop is immediate response time. Using the `PeekMessage()` in Windows API has the same advantage for immediate response (but is rarely needed in current multitasking operating systems).

However, spin loops and `PeekMessage()` in message loops require the constant attention of the processor, preventing it from entering lower power states. Use them sparingly and replace them with the appropriate API when possible. For example:

- When an application needs to wait for more than a few milliseconds, it should avoid using spin loops and use the Windows synchronization APIs, such as `WaitForSingleObject()`.
- When an immediate response is not necessary, an application should avoid using `PeekMessage()`. Use `WaitMessage()` to suspend the thread until a message is in the queue.

Intel® Mobile Platform Software Development Kit provides a rich set of APIs for mobile software to manage and optimize power consumption of mobile processor and other components in the platform.

17.4.2 Reducing Amount of Work

When a processor is in the C0 state, the amount of energy a processor consumes from the battery is proportional to the amount of time the processor executes an active workload. The most obvious technique to conserve power is to reduce the number of cycles it takes to complete a workload (usually that equates to reducing the number of instructions that the processor needs to execute, or optimizing application performance).

Optimizing an application starts with having efficient algorithms and then improving them using Intel software development tools, such as Intel VTune Performance Analyzers, Intel compilers, and Intel Performance Libraries.

See Chapter 3 through Chapter 9 for more information about performance optimization to reduce the time to complete application workloads.

17.4.3 Platform-Level Optimizations

Applications can save power at the platform level by using devices appropriately and redistributing the workload. The following techniques do not impact performance and may provide additional power conservation:

- Read ahead from CD/DVD data and cache it in memory or hard disk to allow the DVD drive to stop spinning.
- Switch off unused devices.
- When developing a network-intensive application, take advantage of opportunities to conserve power. For example, switch to LAN from WLAN whenever both are connected.
- Send data over WLAN in large chunks to allow the WiFi card to enter low power mode in between consecutive packets. The saving is based on the fact that after every send/receive operation, the WiFi card remains in high power mode for up to several seconds, depending on the power saving mode. (Although the purpose keeping the WiFi in high power mode is to enable a quick wake up).

- Avoid frequent disk access. Each disk access forces the device to spin up and stay in high power mode for some period after the last access. Buffer small disk reads and writes to RAM to consolidate disk operations over time. Use the `GetDevicePowerState()` Windows API to test disk state and delay the disk access if it is not spinning.

17.4.4 Handling Sleep State Transitions

In some cases, transitioning to a sleep state may harm an application. For example, suppose an application is in the middle of using a file on the network when the system enters suspend mode. Upon resuming, the network connection may not be available and information could be lost.

An application may improve its behavior in such situations by becoming aware of sleep state transitions. It can do this by using the `WM_POWERBROADCAST` message. This message contains all the necessary information for an application to react appropriately.

Here are some examples of an application reaction to sleep mode transitions:

- Saving state/data prior to the sleep transition and restoring state/data after the wake up transition.
- Closing all open system resource handles such as files and I/O devices (this should include duplicated handles).
- Disconnecting all communication links prior to the sleep transition and re-establishing all communication links upon waking up.
- Synchronizing all remote activity, such as like writing back to remote files or to remote databases, upon waking up.
- Stopping any ongoing user activity, such as streaming video, or a file download, prior to the sleep transition and resuming the user activity after the wake up transition.

Recommendation: *Appropriately handling the suspend event enables more robust, better performing applications.*

17.4.5 Using Enhanced Intel SpeedStep® Technology

Use Enhanced Intel SpeedStep Technology to adjust the processor to operate at a lower frequency and save energy. The basic idea is to divide computations into smaller pieces and use OS power management policy to effect a transition to higher P-states.

Typically, an OS uses a time constant on the order of 10s to 100s of milliseconds¹ to detect demand on processor workload. For example, consider an application that requires only 50% of processor resources to reach a required quality of service (QOS). The scheduling of tasks occurs in such a way that the processor needs to stay in P0 state (highest frequency to deliver highest performance) for 0.5 seconds and may then go to sleep for 0.5 seconds. The demand pattern then alternates.

Thus the processor demand switches between 0 and 100% every 0.5 seconds, resulting in an average of 50% of processor resources. As a result, the frequency switches accordingly between the highest and lowest frequency. The power consumption also switches in the same manner, resulting in an average power usage represented by the equation $P_{average} = (P_{max} + P_{min})/2$.

1. The actual number may vary by OS and by OS release.

Figure 17-4 illustrates the chronological profiles of coarse-grain (> 300 ms) task scheduling and its effect on operating frequency and power consumption.

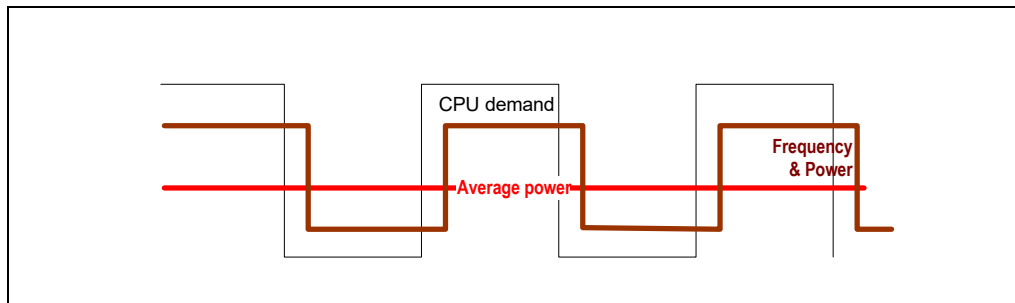

Figure 17-4. Profiles of Coarse Task Scheduling and Power Consumption

The same application can be written in such a way that work units are divided into smaller granularity, but scheduling of each work unit and Sleep() occurring at more frequent intervals (e.g. 100 ms) to deliver the same QOS (operating at full performance 50% of the time). In this scenario, the OS observes that the workload does not require full performance for each 300 ms sampling. Its power management policy may then commence to lower the processor's frequency and voltage while maintaining the level of QOS.

The relationship between active power consumption, frequency and voltage is expressed by the equation:

$$Power = \alpha * C * V^2 * F$$

In the equation: 'V' is core voltage, 'F' is operating frequency, and '\alpha' is the activity factor. Typically, the quality of service for 100% performance at 50% duty cycle can be met by 50% performance at 100% duty cycle. Because the slope of frequency scaling efficiency of most workloads will be less than one, reducing the core frequency to 50% can achieve more than 50% of the original performance level. At the same time, reducing the core frequency to 50% allows for a significant reduction of the core voltage.

Because executing instructions at higher P-state (lower power state) takes less energy per instruction than at P0 state, Energy savings relative to the half of the duty cycle in P0 state ($P_{max}/2$) more than compensate for the increase of the half of the duty cycle relative to inactive power consumption ($P_{min}/2$). The non-linear relationship between power consumption to frequency and voltage means that changing the task unit to finer granularity will deliver substantial energy savings. This optimization is possible when processor demand is low (such as with media streaming, playing a DVD, or running less resource intensive applications like a word processor, email or web browsing).

An additional positive effect of continuously operating at a lower frequency is that frequent changes in power draw (from low to high in our case) and battery current eventually harm the battery. They accelerate its deterioration.

When the lowest possible operating point (highest P-state) is reached, there is no need for dividing computations. Instead, use longer idle periods to allow the processor to enter a deeper low power mode.

17.4.6 Enabling Intel® Enhanced Deeper Sleep

In typical mobile computing usages, the processor is idle most of the time. Conserving battery life must address reducing static power consumption.

Typical OS power management policy periodically evaluates opportunities to reduce static power consumption by moving to lower-power C-states. Generally, the longer a processor stays idle, OS power management policy directs the processor into deeper low-power C-states.

After an application reaches the lowest possible P-state, it should consolidate computations in larger chunks to enable the processor to enter deeper C-States between computations. This technique utilizes the fact that the decision to change frequency is made based on a larger window of time than the period

to decide to enter deep sleep. If the processor is to enter a processor-specific C4 state to take advantage of aggressive static power reduction features, the decision should be based on:

- Whether the QOS can be maintained in spite of the fact that the processor will be in a low-power, long-exit-latency state for a long period.
- Whether the interval in which the processor stays in C4 is long enough to amortize the longer exit latency of this low-power C state.

Eventually, if the interval is large enough, the processor will be able to enter deeper sleep and save a considerable amount of power. The following guidelines can help applications take advantage of Intel® Enhanced Deeper Sleep:

- Avoid setting higher interrupt rates. Shorter periods between interrupts may keep OSes from entering lower power states. This is because transition to/from a deep C-state consumes power, in addition to a latency penalty. In some cases, the overhead may outweigh power savings.
- Avoid polling hardware. In a ACPI C3 type state, the processor may stop snooping and each bus activity (including DMA and bus mastering) requires moving the processor to a lower-numbered C-state type. The lower-numbered state type is usually C2, but may even be C0. The situation is significantly improved in the Intel Core Solo processor (compared to previous generations of the Pentium M processors), but polling will likely prevent the processor from entering into highest-numbered, processor-specific C-state.

17.4.7 Multicore Considerations

Multicore processors deserves some special considerations when planning power savings. The dual-core architecture in Intel Core Duo processor and mobile processors based on Intel Core microarchitecture provide additional potential for power savings for multi-threaded applications.

17.4.7.1 Enhanced Intel SpeedStep® Technology

Using domain-composition, a single-threaded application can be transformed to take advantage of multicore processors. A transformation into two domain threads means that each thread will execute roughly half of the original number of instructions. Dual core architecture enables running two threads simultaneously, each thread using dedicated resources in the processor core. In an application that is targeted for the mobile usages, this instruction count reduction for each thread enables the physical processor to operate at lower frequency relative to a single-threaded version. This in turn enables the processor to operate at a lower voltage, saving battery life.

Note that the OS views each logical processor or core in a physical processor as a separate entity and computes CPU utilization independently for each logical processor or core. On demand, the OS will choose to run at the highest frequency available in a physical package. As a result, a physical processor with two cores will often work at a higher frequency than it needs to satisfy the target QOS.

For example if one thread requires 60% of single-threaded execution cycles and the other thread requires 40% of the cycles, the OS power management may direct the physical processor to run at 60% of its maximum frequency.

However, it may be possible to divide work equally between threads so that each of them require 50% of execution cycles. As a result, both cores should be able to operate at 50% of the maximum frequency (as opposed to 60%). This will allow the physical processor to work at a lower voltage, saving power.

So, while planning and tuning your application, make threads as symmetric as possible in order to operate at the lowest possible frequency-voltage point.

17.4.7.2 Thread Migration Considerations

Interaction of OS scheduling and multicore unaware power management policy may create some situations of performance anomaly for multi-threaded applications. The problem can arise for multithreading application that allow threads to migrate freely.

When one full-speed thread is migrated from one core to another core that has idled for a period of time, an OS without a multicore-aware P-state coordination policy may mistakenly decide that each core demands only 50% of processor resources (based on idle history). The processor frequency may be reduced by such multicore unaware P-state coordination, resulting in a performance anomaly. See Figure 17-5.

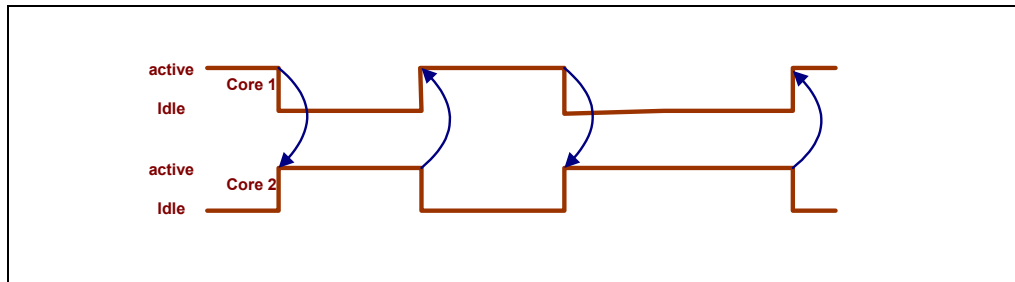

Figure 17-5. Thread Migration in a Multicore Processor

Software applications have a couple of choices to prevent this from happening:

- Thread affinity management — A multi-threaded application can enumerate processor topology and assign processor affinity to application threads to prevent thread migration. This can work around the issue of OS lacking multicore aware P-state coordination policy.
- Upgrade to an OS with multicore aware P-state coordination policy — Some newer OS releases may include multicore aware P-state coordination policy. The reader should consult with specific OS vendors.

17.4.7.3 Multicore Considerations for C-States

There are two issues that impact C-states on multicore processors.

Multicore-unaware C-state Coordination May Not Fully Realize Power Savings

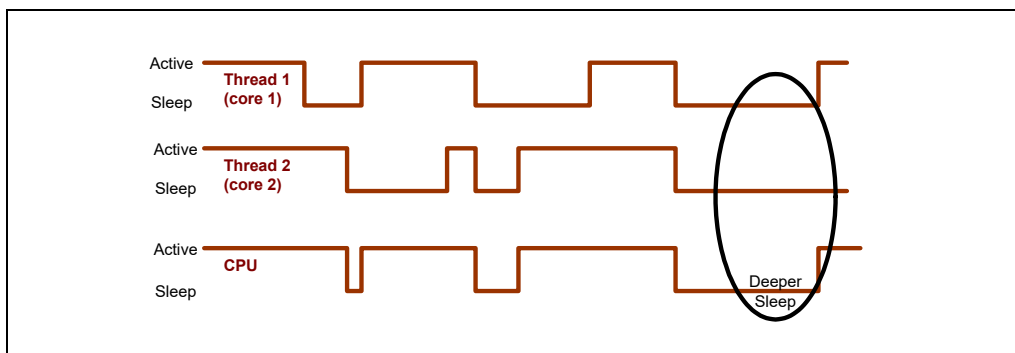

Figure 17-6. Progression to Deeper Sleep

When each core in a multicore processor meets the requirements necessary to enter a different C-state type, multicore-unaware hardware coordination causes the physical processor to enter the lowest possible C-state type (lower-numbered C state has less power saving). For example, if Core 1 meets the requirement to be in ACPI C1 and Core 2 meets requirement for ACPI C3, multicore-unaware OS coordination takes the physical processor to ACPI C1. See Figure 17-6.

Enabling Both Cores to Take Advantage of Intel Enhanced Deeper Sleep.

To best utilize processor-specific C-state (e.g., Intel Enhanced Deeper Sleep) to conserve battery life in multithreaded applications, a multi-threaded application should synchronize threads to work simultaneously and sleep simultaneously using OS synchronization primitives. By keeping the package in a fully idle state longer (satisfying ACPI C3 requirement), the physical processor can transparently take advantage of processor-specific Deep C4 state if it is available.

Multi-threaded applications need to identify and correct load-imbalances of its threaded execution before implementing coordinated thread synchronization. Identifying thread imbalance can be accomplished using performance monitoring events. Intel Core Duo processor provides an event for this purpose. The event (Serial_Execution_Cycle) increments under the following conditions:

- Core actively executing code in C0 state.
- Second core in physical processor in idle state (C1-C4).

This event enables software developers to find code that is executing serially, by comparing Serial_Execution_Cycle and Unhalted_Ref_Cycles. Changing sections of serialized code to execute into two parallel threads enables coordinated thread synchronization to achieve better power savings.

Although Serial_Execution_Cycle is available only on Intel Core Duo processors, application thread with load-imbalance situations usually remains the same for symmetric application threads and on symmetrically configured multicore processors, irrespective of differences in their underlying microarchitecture. For this reason, the technique to identify load-imbalance situations can be applied to multi-threaded applications in general, and not specific to Intel Core Duo processors.

17.5 TUNING SOFTWARE FOR INTELLIGENT POWER CONSUMPTION

This section describes some techniques for tuning software for balance of both power and performance. Most of the power optimization techniques are generic. The last sub section (Section 17.5.8) describes features specific to Sandy Bridge microarchitecture. Explore these features to optimize software for performance and corresponding power benefits.

17.5.1 Reduction of Active Cycles

Finishing the task quicker by reducing the amount of active cycles, then transfer control to the system idle loop will take advantage of modern operating system's power saving optimizations.

Reduction of active cycles can be achieved in several ways, from applying performance-oriented coding techniques discussed in Chapter 3, vectorization using SSE and/or AVX, to multi-threading.

17.5.1.1 Multi-threading to reduce Active Cycles

If given a task of some fixed amount of computational work that has thread-level parallelism, one can apply data-decomposition for multi-threading. The amount of reduction in active cycles will depend on the degree of parallelism. Similar principle can also apply to function-decomposition situations.

A balanced multi-threading implementation is more likely to achieve more optimal results in intelligent efficient performance and power saving benefits. Choosing the right synchronization primitives also has significant impact on both power and performance.

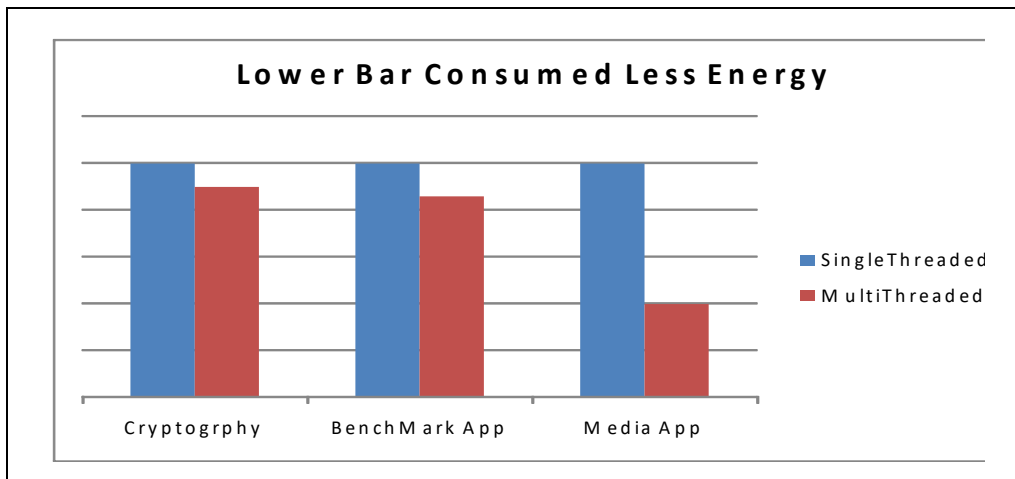

Figure 17-7. Energy Saving due to Performance Optimization

Figure 17-7 above shows the result of a study that compares processor energy consumption of single threaded workloads with their corresponding performance-optimized implementations, using three sets of applications across different application domains. In this particular study, optimization effort in application 1 (Cryptography) achieved 2X gain in performance alone. At the same time, its energy consumption reduced about 12%. In application 3 (a media application), performance optimization efforts including multi-threading and other techniques achieved 10X performance gain. Its energy consumption reduced about 60%.

17.5.1.2 Vectorization

Use SIMD instructions can reduce the path length of completing a given computational task, often reducing active cycles. Code that performs the same operation on multiple independent data elements is a good candidate for vectorization. Vectorization techniques are typically applied to applications with loops with elements that can be processed in single instruction. Typically, the slight power increase per unit time of using SIMD instructions are compensated by much greater reduction of active cycles. The net effect is improved energy consumption.

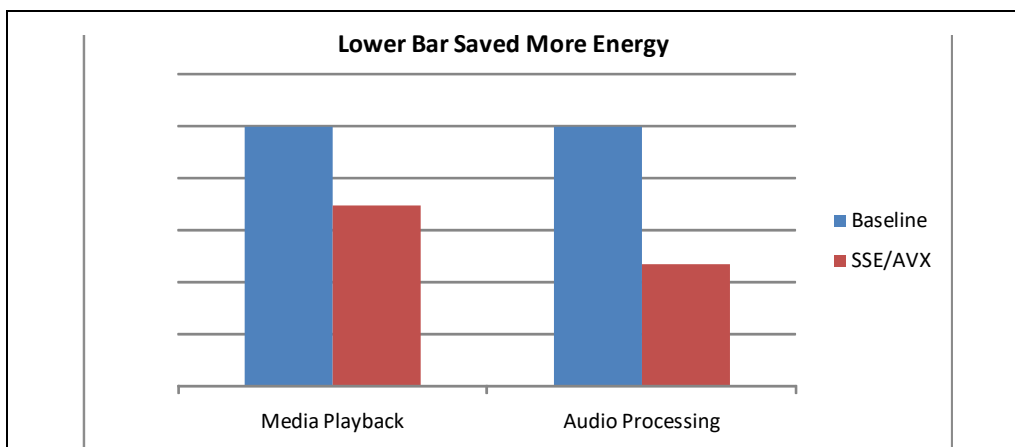

Figure 17-8. Energy Saving due to Vectorization

Figure 17-7 shows the result of a study on the energy saving effect due to vectorization. A media playback workload achieved 2.15X speedup due to using SSE2 and SSE4 instruction sets. Another audio processing workload increased performance to ~5X by using Intel AVX instruction sets. At the same time, the latter also had better energy saving.

17.5.2 PAUSE and Sleep(0) Loop Optimization

In multi-threading implementation, a popular construct in thread synchronization and for yielding scheduling quanta to another thread waiting to carry out its task is to sit in a loop and issuing SLEEP(0).

These are typically called “sleep loops”, see Example 17-1. It should be noted that a SwitchToThread call can also be used. The “sleep loop” is common in locking algorithms and thread pools as the threads are waiting on work.

Example 17-1. Unoptimized Sleep Loop

```
while(!acquire_lock())
{ Sleep( 0 ); }
do_work();
release_lock();
```

This construct of sitting in a tight loop and calling Sleep() service with a parameter of 0 is actually a polling loop with side effects:

- Each call to Sleep() experiences the expensive cost of a context switch, which can be 10000+ cycles.
- It also suffers the cost of ring 3 to ring 0 transitions, which can be 1000+ cycles.
- When there is no other thread waiting to take possession of control, this sleep loop behaves to the OS as a highly active task demanding CPU resource, preventing the OS to put the CPU into a low-power state.

Example 17-2. Power Consumption Friendly Sleep Loop Using PAUSE

```
if (!acquire_lock())
{ /* Spin on pause max_spin_count times before backing off to sleep */
  for(int j = 0; j < max_spin_count; ++j)
  { /* intrinsic for PAUSE instruction*/
    _mm_pause();
    if (read_volatile_lock())
    {
      if (acquire_lock()) goto PROTECTED_CODE;
    }
  }
  /* Pause loop didn't work, sleep now */
  Sleep(0);
  goto ATTEMPT_AGAIN;
}
PROTECTED_CODE:
do_work();
release_lock();
```

Example 17-2 shows the technique of using PAUSE instruction to make the sleep loop power friendly.

By slowing down the “spin-wait” with the PAUSE instruction, the multi-threading software gains:

- Performance by facilitating the waiting tasks to acquire resources more easily from a busy wait.
- Power-savings by both using fewer parts of the pipeline while spinning.
- Elimination of great majority of unnecessarily executed instructions caused by the overhead of a Sleep(0) call.

In one case study, this technique achieved 4.3x of performance gain, which translated to 21% power savings at the processor and 13% power savings at platform level.

17.5.3 Spin-Wait Loops

Use the PAUSE instruction in all spin wait loops. The PAUSE instruction de-pipelines the spin-wait loop to prevent it from consuming execution resources excessively and consuming power needlessly.

When executing a spin-wait loop, the processor can suffer a severe performance penalty when exiting the loop because it detects a possible memory order violation and flushes the core processor's pipeline.

The PAUSE instruction provides a hint to the processor that the code sequence is a spin-wait loop. The processor uses this hint to avoid the memory order violation and prevent the pipeline flush. However, you should try to keep spin-wait loops with PAUSE short.

17.5.4 Using Event Driven Service Instead of Polling in Code

Consistently polling for devices or state changes can cause the platform to wake up and consume more power. Minimize polling whenever possible and use an event driven framework if available. If an OS provides notification services for various device state changes, such as transition from AC to battery, use them instead of polling for device state changes. Using this new event notification framework reduces the overhead for the code to poll the status of the power source, because the code can get notifications asynchronously when status changes happen.

17.5.5 Reducing Interrupt Rate

High interrupt rate may have two consequences that impact processor power and performance:

- It prevents the processor package and its cores from going into deeper sleep states (C-states), which means that the system does not enable the hardware to utilize the power saving features.
- It limits the frequency to which Intel Turbo Boost Technology 2.0 can reach, and therefore the performance of other applications running on the processor degrades.

If a user session and/or an application experiences a rate of thousands of interrupts per second, it would have inhibited the processor to achieve intelligent balance between performance and saving power.

To avoid this situation minimize sporadic wakeups. Schedule all periodic activities of an application or driver into one wakeup period and reduce the interrupt rate to the minimum required.

Many media applications set a very high timer tick rate (1ms). Where possible, use the operating system default timer tick rate. If high granularity is absolutely necessary make sure the software resets the timer tick rate when the task finishes.

17.5.6 Reducing Privileged Time

Applications spending significant time in privileged mode lead to excessive energy use due to various reasons. Some examples are: high system call rate and IO bottlenecks. You can use Windows Perfmon to get an estimate of privileged mode time.

A high system call rate, as measured by system calls per second, indicates that the software is causing frequent kernel mode transitions. That is, the application jumps from Ring3 - user mode to Ring0 - kernel

mode, frequently. A very common example of this is using an expensive synchronization call such as the Win32 API `WaitForSingleObject()`. This is a very important synchronization API, especially for inter-process communication. However, it enters kernel mode irrespective of whether the lock is achieved or not. For multi-threaded code with no or a short period contention on the lock, you can use `EnterCriticalSection` with a spin count. The advantage of this API over `WaitForSingleObject()` is that it does not enter kernel mode unless there is a contention on the lock. Hence, when there is no contention, `EnterCriticalSection` with spin count is much cheaper to use and reduces the time spent in privilege mode.

Studies were done by taking a small test application which has four active threads on a Sandy Bridge microarchitecture-based system. The locks in the test case were implemented by using `WaitForSingleObject` and `EnterCriticalSection`. There was no contention on the lock, so each thread achieved the lock at the first attempt. As shown in the graph below, when there is no contention, using `WaitForSingleObject()` has negative impact on both power and performance as compared to using `EnterCriticalSection()`.

As indicated in the following graph, using `WaitForSingleObject()` on an un-contended lock uses more power. Using `EnterCriticalSection()` provides a 10x performance gain and 60% energy reduction.

For more information see: <https://software.intel.com/en-us/articles/implementing-scalable-atomic-locks-for-multi-core-intel-em64t-and-ia32-architectures>.

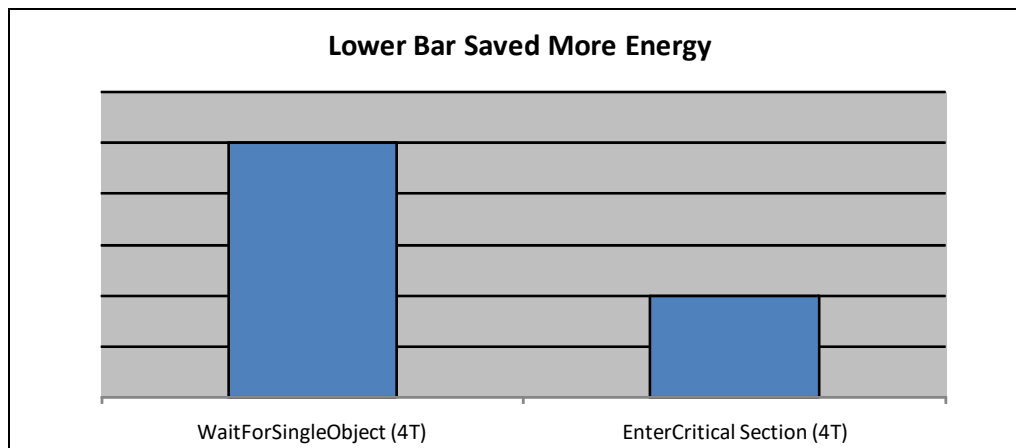

Figure 17-9. Energy Saving Comparison of Synchronization Primitives

17.5.7 Setting Context Awareness in the Code

Context awareness provides a way for software to save power when energy resources are limited. The following are some examples of context awareness that you can implement to conserve power:

- When running a game on laptop on battery power, change the frame rate to 60FPS instead of running uncapped.
- Dim the display when running on battery and not in use.
- Provide easy options for the end user to turn off devices such as wireless when not connected to network

Applications can do these changes transparently when running the game on battery power, or provide hints to users how to extend battery life. For either case, the application needs to be context aware to identify when battery power is in use as opposed to AC power.

A study done with two games running at different frame rates. The blue bar represents baseline default frame rate (uncapped) for these games. The brown line represents games running at 60FPS and the yellow line represents games running at 30FPS. This study shows that capping frame rate can help reduce power consumption.

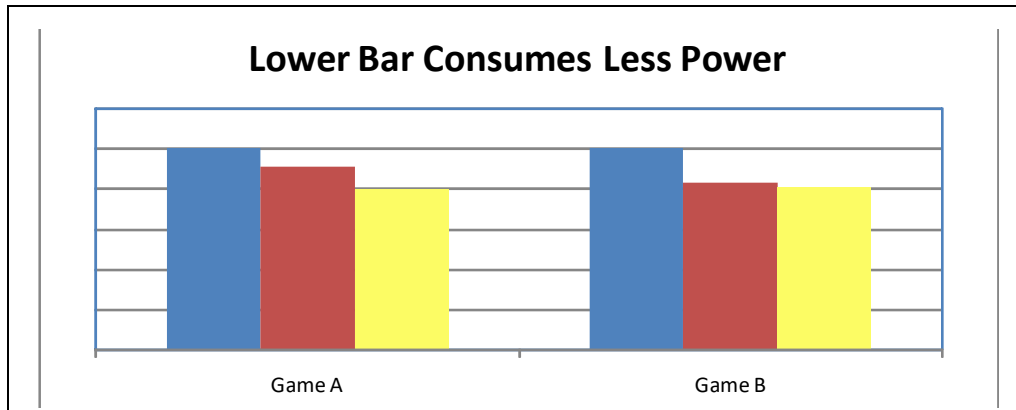

Figure 17-10. Power Saving Comparison of Power-Source-Aware Frame Rate Configurations

17.5.8 Saving Energy by Optimizing for Performance

As general rule, performance optimizations that reduce the number of cycles the CPU is busy running code also save energy consumption. Here are some examples of optimizing performance for specific microarchitectural features that produced energy savings.

The additional load port feature of Sandy Bridge microarchitecture can save cycles, as demonstrated in Section 3.6.1. As a result the load port feature also saves power. For example, in an experiment with the kernel in Section 3.6.1.3, a sample application running on an engineering system with and without a bank conflict, the version without the bank conflict utilizes the second load port and provided a performance improvement along with 25mWhr energy savings.

Another features, the Decoded ICache and the LSD, cache micro-ops, hence eliminating power consumption by the decoders. For example, using the code alignment technique of arranging no more than three unconditional branches within an aligned 32 byte chunk (see Section 3.4.2.5) for switch statement, where we see 1.23x speedup, helps provide 1.12x power saving as well compared to the aligned version of dense unconditional branches in 32-byte chunk that can not fit the decoded ICache.

Using vectorization with Intel AVX allows processing of several elements in one cycle, hence reducing the overall processing cycles and saving energy. An example for the energy saving is shown in Figure 17-8.

17.6 PROCESSOR SPECIFIC POWER MANAGEMENT OPTIMIZATION FOR SYSTEM SOFTWARE

This section covers power management information that is processor specific. This information applies to the second generation Intel Core processors based on Sandy Bridge microarchitecture. These processors have CPUID DisplayFamily_DisplayModel signature of 06_2AH. These processor-specific capabilities may help system software to optimize/balance responsiveness and power consumption of the processor.

17.6.1 Power Management Recommendation of Processor-Specific Inactive State Configurations

Programming ACPI's `_CST` object with exit latency values appropriate to various inactive states will help OS power management to deliver optimal power reduction. Intel recommended values are model-specific.

Table 17-3 and Table 17-4 list Package C-State entry/exit latency for processors with CPUID DisplayFamily_DisplayModel signature of 06_2AH, and for two configurations of voltage regulator slew rate capabilities. Table 17-3 applies to slow VR configuration, and Table 17-4 applies to fast VR configuration. For each configuration, the VR device can operate in either a fast interrupt break mode enabled or slow interrupt break mode, depending on the setting of MSR_POWER_CTL[bit 4]. These C-State entry/exit latency are not processor specifications but estimates derived from empirical measurements. There may be some situations exit latency from a core is higher than those listed in Table 17-3 and Table 17-4.

Table 17-3. C-State Total Processor Exit Latency for Client Systems (Core+ Package Exit Latency) with Slow VR

C-State ¹	Typical Exit Latency ²	Worst Case Exit Latency
	MSR_POWER_CTL MSR.[4] =0	MSR_POWER_CTL MSR.[4] =1
C1	1 μ s	1 μ s
C3	156 μ s	80 μ s
C6	181 μ s	104 μ s
C7	199 μ s	109 μ s

NOTES:

1. These C-State Entry/Exit Latencies are Intel estimates only and not processor specifications.
2. It is assumed that package is in C0 when one of the core is active.
3. Fast interrupt break mode is enabled if MSR_POWER_CTL.[4] = 1.
4. A device that connect to PCH may result in latencies equivalent to that of a slow interrupt break mode.

Table 17-4. C-State Total Processor Exit Latency for Client Systems (Core+ Package Exit Latency) with Fast VR

C-State ¹	Typical Worst Case Exit Latency Time (All Skus) ²	
	MSR_POWER_CTL MSR.[4] =0	MSR_POWER_CTL MSR.[4] =1
C1	1 μ s	1 μ s
C3	156 μ s	80 μ s
C6	181 μ s	104 μ s
C7	199 μ s	109 μ s

NOTES:

1. These C-State Entry/Exit Latencies are Intel estimates only and not processor specifications.
2. It is assumed that package is in C0 when one of the core is active.
3. If the package is in a deeper C-states, the exit latency of Local APIC timer wake up depends on the typical core level exit latency; If the package is in C0, it may vary between typical or worst case of the respective core-level exit latency.

Table 17-5 lists Core-only C-State entry/exit latency for processors with CPUID DisplayFamily_Display-Model signature of 06_2AH, and for two configurations of voltage regulator slew rate capabilities. Core-only exit latency is not affected by MSR_POWER_CTL[4].

Table 17-5. C-State Core-Only Exit Latency for Client Systems with Slow VR

C-State ¹	Typical Worst Case Exit Latency Time (All Skus) ²	
	Fast Mode	Slow Mode
C1	1 μ s	1 μ s
C3	21 μ s	240 μ s
C6	46 μ s	250 μ s
C7	46 μ s	250 μ s

NOTES:

1. These C-State Entry/Exit Latencies are Intel estimates only and not processor specifications.
2. A slow VR device refers to a device with ramp time of 10 mv/ μ s in fast mode and 2.5 mv/ μ s in slow mode.

17.6.1.1 Balancing Power Management and Responsiveness of Inactive To Active State Transitions

MSR_PKG_C3_IRTL, MSR_PKG_C6_IRTL, MSR_PKG_C7_IRTL provide processor-specific interfaces for system software to balance power consumption and system responsiveness. System software may change budgeted values from a package inactive states to C0 during runtime to accommodate system specific requirements. For example, more aggressive timings when on battery vs. on AC power.

The exit latency is greatly impacted by the VR swing rate. Table 17-5 specifies the total interrupt response times per state (including the core component) for a “fast” exit rate (the default recommended configuration in the PCH and CPU for all events except the internal HPET and CPU timers).

Selecting a “slow” rate by the BIOS (disable the fast break event method in the POWER_CTL MSR bit 4) for various events from the PCIE will require extending the above budget respectively. Otherwise CPU may select a shallower PKG_Cstate to still meet the budget at a much slower VR swing rate.

Selecting a “slow” exit rate for various PCH-connected devices (PCH BIOS setting) will not be visible to the above latency calculation mechanism and thus result in the CPU not meeting the required latency goals.

Table 17-6. POWER_CTL MSR in Processors Based on Sandy Bridge Microarchitecture

Register Address		Register Name	Scope	Bit Description
Hex	Dec			
1FCH	508	MSR_POWER_CTL	Core	Power Control Register
		3:0		Reserved.
		4		FAST_Brk_Int_En. When set to 1, enables the voltage regulator for fast slope for PCI-E interrupt wakeup events.
		63:5		Reserved.

CHAPTER 18

SOFTWARE OPTIMIZATION FOR INTEL® AVX-512 INSTRUCTIONS

Intel® Advanced Vector Extensions 512 (Intel® AVX-512) are the following set of 512-bit instruction set extensions supported by recent microarchitectures, beginning with Skylake server microarchitecture, and the Intel® Xeon Phi™ processors based on Knights Landing microarchitecture.

- Intel® AVX-512 Foundation (F)
 - 512-bit vector width.
 - 32 512-bit long vector registers.
 - Data expand and data compress instructions.
 - Ternary logic instruction.
 - 8 new 64-bit long mask registers.
 - Two source cross-lane permute instructions.
 - Scatter instructions.
 - Embedded broadcast/rounding.
 - Transcendental support.
- Intel® AVX-512 Conflict Detection Instructions (CD)
- Intel® AVX-512 Exponential and Reciprocal Instructions (ER)
- Intel® AVX-512 Prefetch Instructions (PF)
- Intel® AVX-512 Byte and Word Instructions (BW)
- Intel® AVX-512 Double Word and Quad Word Instructions (DQ)
 - New QWORD and Compute and Convert Instructions.
- Intel® AVX-512 Vector Length Extensions (VL)

The Venn diagram below shows the different extensions supported by the two processor families.

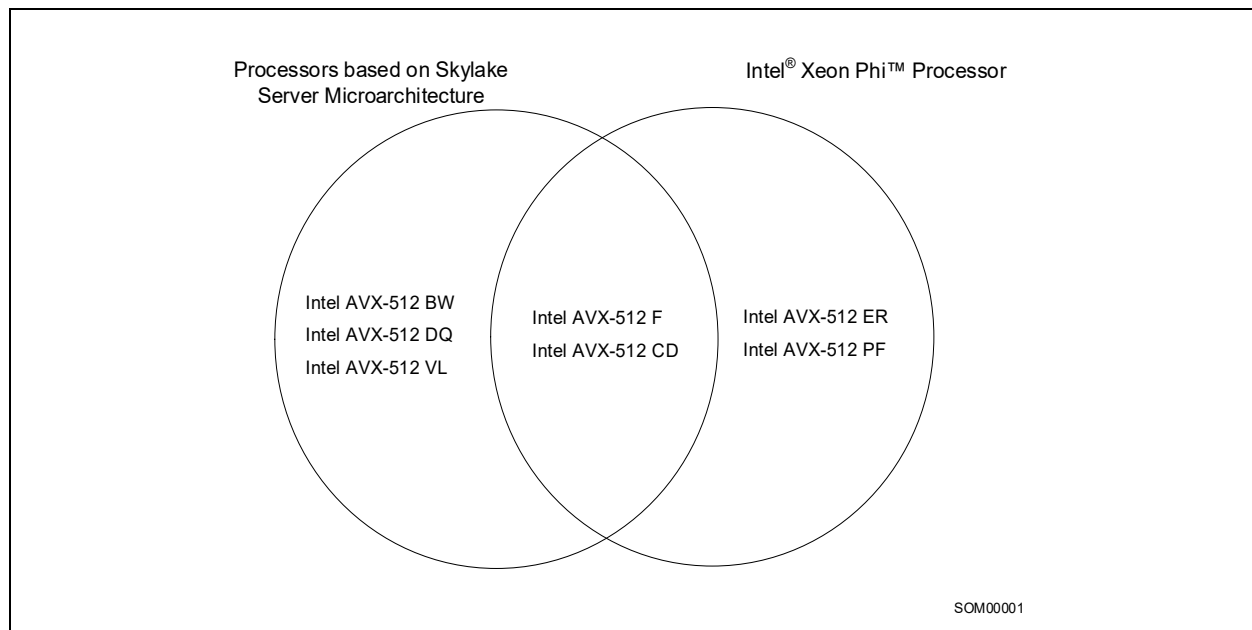

Figure 18-1. Intel® AVX-512 Extensions Supported by Skylake Server Microarchitecture and Knights Landing Microarchitecture

Performance reports in this chapter are based on Data Cache Unit (DCU) resident data measurements on the Skylake Server System with Intel® Turbo-Boost technology disabled, Intel® SpeedStep® Technology disabled, core and uncore frequency set to 1.8GHz, unless otherwise specified. This fixed frequency configuration is used in order to isolate code change impacts from other factors. See Section 2.5.3, “Skylake Server Power Management”, to understand the power and frequency impacts of using Intel AVX-512.

18.1 BASIC INTEL® AVX-512 VS. INTEL® AVX2 CODING

In most cases, the main performance driver for Intel AVX-512 will be the 512-bit register width. This section demonstrates the similarity and differences between basic Intel AVX2 and Intel AVX-512 code and explains how to convert code from Intel AVX2 to Intel AVX-512 easily. The first sub section demonstrates the conversion of intrinsic code and the second sub-section of assembly code. The following sections highlight advanced aspects that require consideration and treatment when doing such conversions.

The examples in the following subsections implement a Cartesian coordinate system rotation. A point in a Cartesian coordinate system is described by the pair (x,y). The following picture demonstrates a Cartesian rotation of (x,y) by angle θ to (x',y').

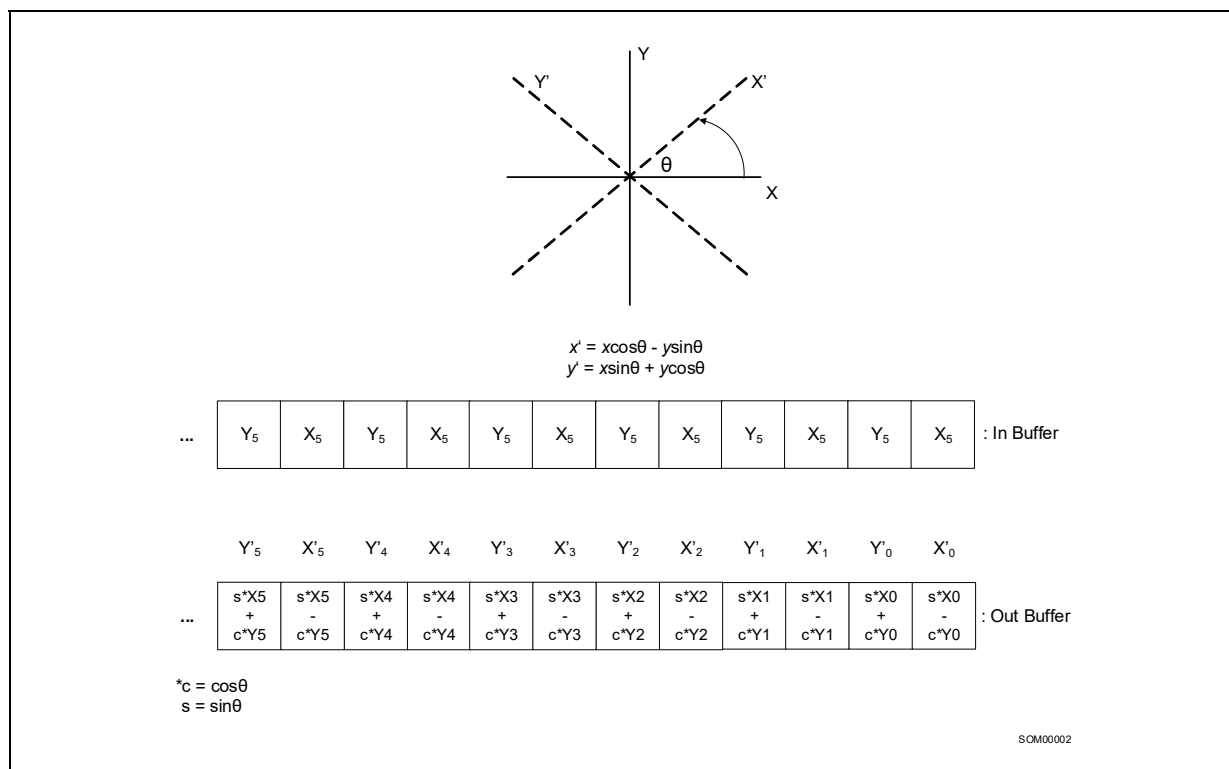

Figure 18-2. Cartesian Rotation

18.1.1 Intrinsic Coding

The following comparison of Intel AVX2 and Intel AVX-512 shows how to convert a simple intrinsic Intel AVX2 code sequence to Intel AVX-512. This example demonstrates the Intel AVX Instruction format, 64 byte ZMM registers, dynamic and static memory allocation with data alignment of 64bytes, and the C data type representing 16 floating point elements in a ZMM register. Follow these guidelines when doing this transformation.

- Align statically and dynamically allocated buffers to 64-bytes.
- Use a double supplemental buffer size for constants.
- Change `__mm256_` intrinsic name prefix with `__mm512_`.
- Change variable data types names from `__m256` to `__m512`.
- Divide by 2 iteration count (double stride length).

Example 18-1. Cartesian Coordinate System Rotation with Intrinsics

Intel® AVX2 Intrinsics Code	Intel® AVX-512 Intrinsics Code
<pre>#include <immintrin.h> int main() { int len = 3200; //Dynamic memory allocation with 32byte //alignment float* pInVector = (float *) __mm_malloc(len*sizeof(float),32); float* pOutVector = (float *) __mm_malloc(len*sizeof(float),32); //init data for (int i=0; i<len; i++) pInVector[i] = 1; float cos_teta = 0.8660254037; float sin_teta = 0.5; //Static memory allocation of 8 floats with 32byte align- ments __declspec(align(32)) float cos_sin_teta_vec[8] = {cos_teta, sin_teta, cos_teta, sin_teta, cos_teta, sin_teta, cos_teta, sin_teta}; __declspec(align(32)) float sin_cos_teta_vec[8] = {sin_teta, cos_teta, sin_teta, cos_teta, sin_teta, cos_teta, sin_teta, cos_teta}; //__m256 data type represents a Ymm // register with 8 float elements __m256 Ymm_cos_sin = __mm256_ load_ps(cos_sin_teta_vec);</pre>	<pre>#include <immintrin.h> int main() { int len = 3200; //Dynamic memory allocation with 64byte //alignment float* pInVector = (float *) __mm_malloc(len*sizeof(float),64); float* pOutVector = (float *) __mm_malloc(len*sizeof(float),64); //init data for (int i=0; i<len; i++) pInVector[i] = 1; float cos_teta = 0.8660254037; float sin_teta = 0.5; //Static memory allocation of 16 floats with 64byte align- ments __declspec(align(64)) float cos_sin_teta_vec[16] = {cos_teta, sin_teta, cos_teta, sin_teta, cos_teta, sin_teta, cos_teta, sin_teta, cos_teta, sin_teta, cos_teta, sin_teta, cos_teta, sin_teta, cos_teta, sin_teta}; __declspec(align(64)) float sin_cos_teta_vec[16] = {sin_teta, cos_teta, sin_teta, cos_teta, sin_teta, cos_teta, sin_teta, cos_teta, sin_teta, cos_teta, sin_teta, cos_teta, sin_teta, cos_teta, sin_teta, cos_teta}; //__m512 data type represents a Zmm // register with 16 float elements __m512 Zmm_cos_sin = __mm512_ load_ps(cos_sin_teta_vec);</pre>

Example 18-1. Cartesian Coordinate System Rotation with Intrinsics (Contd.)

<pre> //Intel® AVX2 256bit packed single load __m256 Ymm_sin_cos = _mm256_- load_ps(sin_cos_teta_vec); __m256 Ymm0, Ymm1, Ymm2, Ymm3; //processing 16 elements in an unrolled //twice loop for(int i=0; i<len; i+=16) { Ymm0 = _mm256_load_ps(plnVector+i); Ymm1 = _mm256_moveldup_ps(Ymm0); Ymm2 = _mm256_movehdup_ps(Ymm0); Ymm2 = _mm256_mul_ps(Ymm2,Ymm_sin_cos); Ymm3 = _mm256_fmaddsub_ps(Ymm1,Ymm_cos_sin,Ymm2); _mm256_store_ps(pOutVector + i,Ymm3); Ymm0 = _mm256_load_ps(plnVector+i+8); Ymm1 = _mm256_moveldup_ps(Ymm0); Ymm2 = _mm256_movehdup_ps(Ymm0); Ymm2 = _mm256_mul_ps(Ymm2, Ymm_sin_cos); Ymm3 = _mm256_fmaddsub_ps(Ymm1,Ymm_cos_sin,Ymm2); _mm256_store_ps(pOutVector+i+8,Ymm3); } _mm_free(plnVector); _mm_free(pOutVector); return 0; } </pre>	<pre> //Intel® AVX-512 512bit packed single load __m512 Zmm_sin_cos = _mm512_- load_ps(sin_cos_teta_vec); __m512 Zmm0, Zmm1, Zmm2, Zmm3; //processing 32 elements in an unrolled //twice loop for(int i=0; i<len; i+=32) { Zmm0 = _mm512_load_ps(plnVector+i); Zmm1 = _mm512_moveldup_ps(Zmm0); Zmm2 = _mm512_movehdup_ps(Zmm0); Zmm2 = _mm512_mul_ps(Zmm2,Zmm_sin_cos); Zmm3 = _mm512_fmaddsub_ps(Zmm1,Zmm_cos_sin,Zmm2); _mm512_store_ps(pOutVector + i,Zmm3); Zmm0 = _mm512_load_ps(plnVector+i+16); Zmm1 = _mm512_moveldup_ps(Zmm0); Zmm2 = _mm512_movehdup_ps(Zmm0); Zmm2 = _mm512_mul_ps(Zmm2, Zmm_sin_cos); Zmm3 = _mm512_fmaddsub_ps(Zmm1,Zmm_cos_sin,Zmm2); _mm512_store_ps(pOutVector+i+16,Zmm3); } _mm_free(plnVector); _mm_free(pOutVector); return 0; } </pre>
Baseline	Speedup: 1.95x

18.1.2 Assembly Coding

Similar to the intrinsic porting guidelines, assembly porting guidelines are listed below:

- Align statically and dynamically allocated buffers to 64-bytes.
- Double the supplemental buffer sizes if needed.
- Add a “v” prefix to instruction names.
- Change register names from ymm to zmm.
- Divide the iteration count by two (or double stride length).

Example 18-2. Cartesian Coordinate System Rotation with Assembly

Intel® AVX2 Assembly Code	Intel® AVX-512 Assembly Code
<pre> #include <immintrin.h> int main() { int len = 3200; //Dynamic memory allocation with 32byte alignment float* plnVector = (float *) _mm_malloc(len*sizeof(float),32); float* pOutVector = (float *) _mm_malloc(len*sizeof(float),32); //init data for (int i=0; i<len; i++) plnVector[i] = 1; float cos_teta = 0.8660254037; float sin_teta = 0.5; //Static memory allocation of 8 floats with 32byte align- ments __declspec(align(32)) float cos_sin_teta_vec[8] = {cos_teta, sin_teta, cos_teta, sin_teta, cos_teta, sin_teta}; __declspec(align(32)) float sin_cos_teta_vec[8] = {sin_teta, cos_teta, sin_teta, cos_teta, sin_teta, cos_teta, sin_teta, cos_teta}; __asm { mov rax,plnVector mov r8,pOutVector // Load into a ymm register of 32 bytes vmovups ymm3, ymmword ptr[cos_sin_teta_vec] vmovups ymm4, ymmword ptr[sin_cos_teta_vec] mov edx, len shl edx, 2 xor ecx, ecx loop1: vmovsldup ymm0, [rax+rcx] vmovshdup ymm1, [rax+rcx] vmulps ymm1, ymm1, ymm4 vfmaddsub213ps ymm0, ymm3, ymm1 // 32 byte store from a ymm register vmovaps [r8+rcx], ymm0 </pre>	<pre> #include <immintrin.h> int main() { int len = 3200; //Dynamic memory allocation with 64byte alignment float* plnVector = (float *) _mm_malloc(len*sizeof(float),64); float* pOutVector = (float *) _mm_malloc(len*sizeof(float),64); //init data for (int i=0; i<len; i++) plnVector[i] = 1; float cos_teta = 0.8660254037; float sin_teta = 0.5; //Static memory allocation of 16 floats with 64byte align- ments __declspec(align(64)) float cos_sin_teta_vec[16] = {cos_teta, sin_teta, cos_teta, sin_teta, cos_teta, sin_teta, cos_teta, sin_teta, cos_teta, sin_teta, cos_teta, sin_teta, cos_teta, sin_teta, cos_teta, sin_teta}; __declspec(align(64)) float sin_cos_teta_vec[16] = {sin_teta, cos_teta, sin_teta, cos_teta, sin_teta, cos_teta, sin_teta, cos_teta, sin_teta, cos_teta, sin_teta, cos_teta, sin_teta, cos_teta, sin_teta, cos_teta}; __asm { mov rax,plnVector mov r8,pOutVector // Load into a zmm register of 64 bytes vmovups zmm3, zmmword ptr[cos_sin_teta_vec] vmovups zmm4, zmmword ptr[sin_cos_teta_vec] mov edx, len shl edx, 2 xor ecx, ecx loop1: vmovsldup zmm0, [rax+rcx] vmovshdup zmm1, [rax+rcx] vmulps zmm1, zmm1, zmm4 vfmaddsub213ps zmm0, zmm3, zmm1 // 64 byte store from a zmm register vmovaps [r8+rcx], zmm0 </pre>

Example 18-2. Cartesian Coordinate System Rotation with Assembly (Contd.)

<pre> vmovsldup ymm0, [rax+rcx+32] vmovshdup ymm1, [rax+rcx+32] vmulps ymm1, ymm1, ymm4 vfmaddsub213ps ymm0, ymm3, ymm1 // offset 32 bytes from previous store vmovaps [r8+rcx+32], ymm0 // Processed 64bytes in this loop // (the code is unrolled twice) add ecx, 64 cmp ecx, edx jl loop1 } _mm_free(plnVector); _mm_free(pOutVector); return 0; } </pre>	<pre> vmovsldup zmm0, [rax+rcx+64] vmovshdup zmm1, [rax+rcx+64] vmulps zmm1, zmm1, zmm4 vfmaddsub213ps zmm0, zmm3, zmm1 // offset 64 bytes from previous store vmovaps [r8+rcx+64], zmm0 // Processed 128bytes in this loop // (the code is unrolled twice) add ecx, 128 cmp ecx, edx jl loop1 } _mm_free(plnVector); _mm_free(pOutVector); return 0; } </pre>
Baseline	Speedup: 1.95x

18.2 MASKING

Intel AVX-512 instructions which use the Extended VEX coding scheme (EVEX) encode a predicate operand to conditionally control per-element computational operation and update the result to the destination operand. The predicate operand is known as the opmask register. The opmask is a set of eight architectural registers, 64 bits each. From this set of 8 architectural registers, only k1 through k7 can be addressed as the predicate operand; k0 can be used as a regular source or destination but cannot be encoded as a predicate operand.

A predicate operand can be used to enable memory fault-suppression for some instructions with a memory source operand.

As a predicate operand, the opmask registers contain one bit to govern the operation / update of each data element of a vector register. Masking is supported on Skylake microarchitecture for instructions with all data sizes: byte (int8), word (int16), single precision floating-point (float32), integer doubleword (int32), double precision floating-point (float64), integer quadword (int64). Therefore, a vector register holds either 8, 16, 32 or 64 elements; accordingly, the length of a vector mask register is 64 bits.

Masking on Skylake microarchitecture is also enabled for all vector length values: 128-bit, 256-bit and 512-bit. Each instruction accesses only the number of least significant mask bits needed based on its data type and vector length. For example, Intel AVX-512 instructions operating on 64-bit data elements with a 512-bit vector length, only use the 8 (i.e., 512/64) least significant bits of the opmask register.

An opmask register affects an Intel AVX-512 instruction at per-element granularity. So, any numeric or non-numeric operation of each data element and per-element updates of intermediate results to the destination operand are predicated on the corresponding bit of the opmask register.

An opmask serving as a predicate operand in Intel AVX-512 has the following properties:

- The instruction's operation is only performed for an element if the corresponding opmask bit is set. This implies that no exception or violation can be caused by an operation on a masked-off element. Consequently, no MXCSR exception flag is updated as a result of a masked-off operation.
- A destination element is not updated with the result of the operation if the corresponding writemask bit is not set. Instead, the destination element value may be preserved (merging-masking) or zeroed out (zeroing-masking).
- For some instructions with a memory operand, memory faults are suppressed for elements with a mask bit of 0.

Note that this feature provides a powerful construct to implement control-flow predication, since the mask provides a merging behavior for Intel AVX-512 vector register destinations. As an alternative the masking can be used for zeroing instead of merging, so that the masked out elements are updated with 0 instead of preserving the old value. The zeroing behavior removes the implicit dependency on the old value when it is not needed.

Most instructions with masking enabled accept both forms of masking. Instructions that must have EVEX.aaa bits different than 0 (gather and scatter) and instructions that write to memory, only accept merging-masking.

The per-element destination update rule also applies when the destination operand is a memory location. Vectors are written on a per element basis, based on the opmask register used as a predicate operand.

The value of an opmask register can be:

- Generated as a result of a vector instruction (CMP, FPCLASS, etc.).
- Loaded from memory.
- Loaded from GPR register.
- Modified by mask-to-mask operations.

18.2.1 Masking Example

The masked instructions conditionally operate with packed data elements, depending on the mask bits associated with each data element. The mask bit for each data element is the corresponding bit in the mask register.

When performing a mask instruction, the returned value is 0 for elements which have a corresponding mask value of 0. The corresponding value in the destination register depends on the zeroing flag:

- If the flag is set, the memory location is filled with zeros.
- If the flag is not set, the values in memory location can be preserved.

The following figures show an example for a mask move from one register to another when using merging masking.

```
vmovaps zmm1 {k1}, zmm0
```

The destination register before instruction execution is shown below.

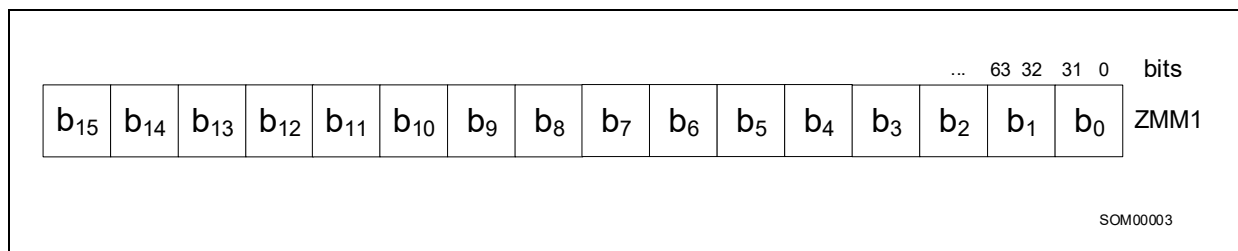

Operation is as follows.

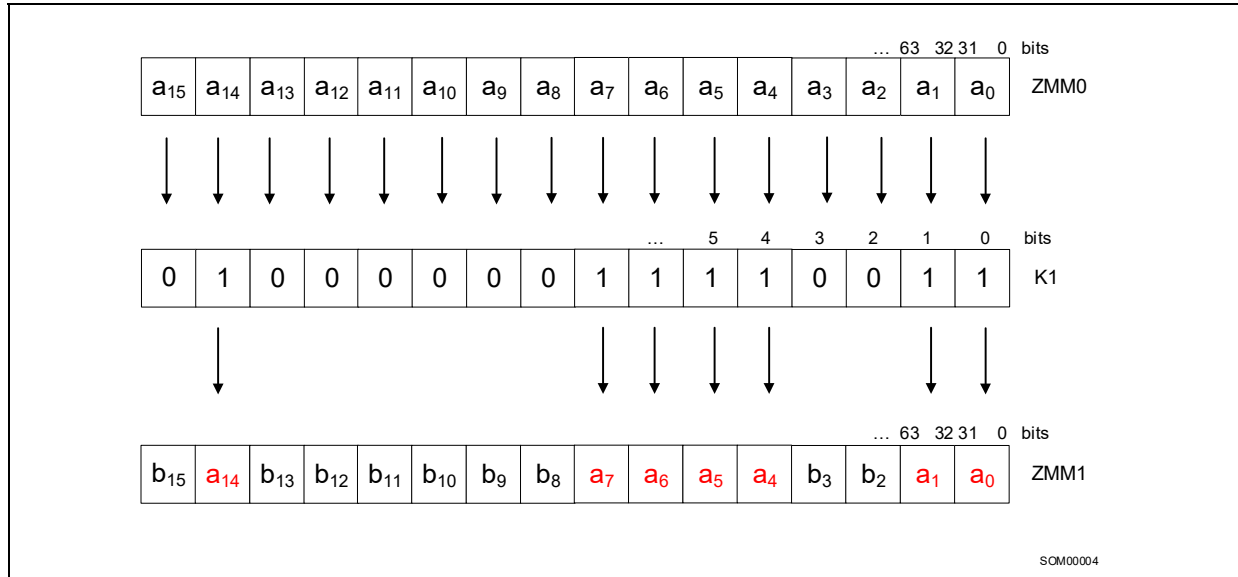

The result of the execution with zeroing masking is (notice the {z} in the instruction):

```
vmovaps zmm1 {k1}{z}, zmm0
```

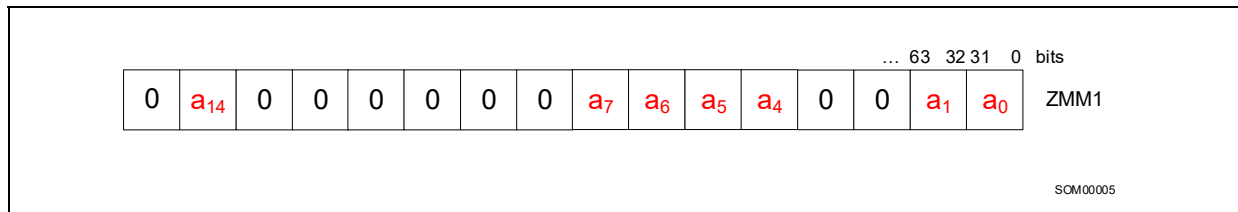

Notice that merging masking operations has a dependency on the destination, but zeroing masking is free of such dependency.

The following example shows how masking could be done with Intel AVX-512 in contrast to Intel AVX2.

C Code:

```
const int N = miBufferWidth;
const double* restrict a = A;
const double* restrict b = B;
double* restrict c = Cref;

for (int i = 0; i < N; i++){
    double res = b[i];
    if(a[i] > 1.0){
        res = res * a[i];
    }
    c[i] = res;
}
```

Example 18-3. Masking with Intrinsics

Intel® AVX2 Intrinsics Code	Intel® AVX-512 Intrinsics Code
<pre> for (int i = 0; i < N; i+=32){ __m256d aa, bb, mask; #pragma unroll(8) for (int j = 0; j < 8; j++){ aa = _mm256_loadu_pd(a+i+j*4); bb = _mm256_loadu_pd(b+i+j*4); mask = _mm256_c- mp_pd(_mm256_set1_pd(1.0), aa, 1); aa = _mm256_and_pd(aa, mask); // zero the false values aa = _mm256_mul_pd(aa, bb); bb = _mm256_blendv_pd(bb, aa, mask); _mm256_storeu_pd(c+4*j, bb); } c += 32; } </pre>	<pre> for (int i = 0; i < N; i+=32){ __m512d aa, bb; __mmask8 mask; #pragma unroll(4) for (int j = 0; j < 4; j++){ aa = _mm512_loadu_pd(a+i+j*8); bb = _mm512_loadu_pd(b+i+j*8); mask = _mm512_cmp_p- d_mask(_mm512_set1_pd(1.0), aa, 1); bb = _mm512_mask_mul_pd(bb, mask, aa, bb); _mm512_storeu_pd(c+8*j, bb); } c += 32; } </pre>
Baseline	Speedup: 2.9x

Example 18-4. Masking with Assembly

Intel® AVX2 Assembly Code	Intel® AVX-512 Assembly Code
<pre> mov rax, a mov r11, b mov r8, N shr r8, 5 mov rsi, c xor rcx, rcx xor r9, r9 loop: vmovupd ymm1, ymmword ptr [rax+rcx*8] inc r9d vmovupd ymm6, ymmword ptr [rax+rcx*8+0x20] vmovupd ymm2, ymmword ptr [r11+rcx*8] vmovupd ymm7, ymmword ptr [r11+rcx*8+0x20] vmovupd ymm11, ymmword ptr [rax+rcx*8+0x40] vmovupd ymm12, ymmword ptr [r11+rcx*8+0x40] vcmppd ymm4, ymm0, ymm1, 0x1 vcmppd ymm9, ymm0, ymm6, 0x1 vcmppd ymm14, ymm0, ymm11, 0x1 vandpd ymm16, ymm1, ymm4 vandpd ymm17, ymm6, ymm9 </pre>	<pre> mov rax, a mov r11, b mov r8, N shr r8, 5 mov rsi, c xor rcx, rcx xor r9, r9 mov rdi, 1 cvtsi2sd xmm8, rdi vbroadcastsd zmm8, xmm8 loop: vmovups zmm0, zmmword ptr [rax+rcx*8] inc r9d vmovups zmm2, zmmword ptr [rax+rcx*8+0x40] vmovups zmm4, zmmword ptr [rax+rcx*8+0x80] vmovups zmm6, zmmword ptr [rax+rcx*8+0xc0] vmovups zmm1, zmmword ptr [r11+rcx*8] vmovups zmm3, zmmword ptr [r11+rcx*8+0x40] vmovups zmm5, zmmword ptr [r11+rcx*8+0x80] vmovups zmm7, zmmword ptr [r11+rcx*8+0xc0] </pre>

Example 18-4. Masking with Assembly (Contd.)

<pre> vmulpd ymm3, ymm16, ymm2 vmulpd ymm8, ymm17, ymm7 vmovupd ymm1, ymmword ptr [rax+rcx*8+0x60] vmovupd ymm6, ymmword ptr [rax+rcx*8+0x80] vblendvpd ymm5, ymm2, ymm3, ymm4 vblendvpd ymm10, ymm7, ymm8, ymm9 vmovupd ymm2, ymmword ptr [r11+rcx*8+0x60] vmovupd ymm7, ymmword ptr [r11+rcx*8+0x80] vmovupd ymmword ptr [rsi], ymm5 vmovupd ymmword ptr [rsi+0x20], ymm10 vcmpdpd ymm4, ymm0, ymm1, 0x1 vcmpdpd ymm9, ymm0, ymm6, 0x1 vandpd ymm18, ymm11, ymm14 vandpd ymm19, ymm1, ymm4 vandpd ymm20, ymm6, ymm9 vmulpd ymm13, ymm18, ymm12 vmulpd ymm3, ymm19, ymm2 vmulpd ymm8, ymm20, ymm7 vmovupd ymm11, ymmword ptr [rax+rcx*8+0xa0] vmovupd ymm1, ymmword ptr [rax+rcx*8+0xc0] vmovupd ymm6, ymmword ptr [rax+rcx*8+0xe0] vblendvpd ymm15, ymm12, ymm13, ymm14 vblendvpd ymm5, ymm2, ymm3, ymm4 vblendvpd ymm10, ymm7, ymm8, ymm9 vmovupd ymm12, ymmword ptr [r11+rcx*8+0xa0] vmovupd ymm2, ymmword ptr [r11+rcx*8+0xc0] vmovupd ymm7, ymmword ptr [r11+rcx*8+0xe0] vmovupd ymmword ptr [rsi+0x40], ymm15 vmovupd ymmword ptr [rsi+0x60], ymm5 vmovupd ymmword ptr [rsi+0x80], ymm10 vcmpdpd ymm14, ymm0, ymm11, 0x1 vcmpdpd ymm4, ymm0, ymm1, 0x1 vcmpdpd ymm9, ymm0, ymm6, 0x1 vandpd ymm21, ymm11, ymm14 add rcx, 0x20 vandpd ymm22, ymm1, ymm4 vandpd ymm23, ymm6, ymm9 vmulpd ymm13, ymm21, ymm12 vmulpd ymm3, ymm22, ymm2 vmulpd ymm8, ymm23, ymm7 vblendvpd ymm15, ymm12, ymm13, ymm14 vblendvpd ymm5, ymm2, ymm3, ymm4 vblendvpd ymm10, ymm7, ymm8, ymm9 vmovupd ymmword ptr [rsi+0xa0], ymm15 vmovupd ymmword ptr [rsi+0xc0], ymm5 vmovupd ymmword ptr [rsi+0xe0], ymm10 add rsi, 0x100 cmp r9d, r8d jb loop </pre>	<pre> vcmpdpd k1, zmm8, zmm0, 0x1 vcmpdpd k2, zmm8, zmm2, 0x1 vcmpdpd k3, zmm8, zmm4, 0x1 vcmpdpd k4, zmm8, zmm6, 0x1 vmulpd zmm1{k1}, zmm0, zmm1 vmulpd zmm3{k2}, zmm2, zmm3 vmulpd zmm5{k3}, zmm4, zmm5 vmulpd zmm7{k4}, zmm6, zmm7 vmovups zmmword ptr [rsi], zmm1 vmovups zmmword ptr [rsi+0x40], zmm3 vmovups zmmword ptr [rsi+0x80], zmm5 vmovups zmmword ptr [rsi+0xc0], zmm7 add rcx, 0x20 add rsi, 0x100 cmp r9d, r8d jb loop </pre>
Baseline	Speedup: 2.9x

18.2.2 Masking Cost

Using masking may result in lower performance than the corresponding non-masked code. This may be caused by one of the following situations:

- An additional blend operation on each load.
- Dependency on the destination when using merge masking. This dependency does not exist when using zero masking.
- More restrictive masking forwarding rules (see Forwarding and Memory Masking for more information).

The following example shows how using merge masking creates a dependency on the destination register.

Example 18-5. Masking Example

No Masking	Merge Masking	Zero Masking
<pre> mov rbx, iter loop: vmulps zmm0, zmm9, zmm8 vmulps zmm1, zmm9, zmm8 dec rbx jnle loop </pre>	<pre> mov rbx, iter loop: vmulps zmm0{k1}, zmm9, zmm8 vmulps zmm1{k1}, zmm9, zmm8 dec rbx jnle loop </pre>	<pre> mov rbx, iter loop: vmulps zmm0{k1}{z}, zmm9, zmm8 vmulps zmm1{k1}{z}, zmm9, zmm8 dec rbx jnle loop </pre>
Baseline	Slowdown: 4x	Slowdown: Equal to baseline.

With no masking, the processor executes 2 multiplies per cycle on a 2 FMA server.

With merge masking, the processor executes 2 multiplies every 4 cycles as the multiplies in iteration N depend on the output of the multiplies in iteration N-1.

Zero masking does not have a dependency on the destination register and therefore can execute 2 multiplies per cycle on a 2 FMA server.

Recommendation: *Masking has a cost, so use it only when necessary. When possible, use zero masking rather than merge masking.*

18.2.3 Masking vs. Blending

This section discusses the advantages and disadvantages of using blending vs. masking for conditional code.

Consider the following code:

```

for ( i=0; i<SIZE; i++ )
{
    if ( a[i] > 0 )
    {
        b[i] *= 2;
    }
    else
    {
        b[i] /= 2;
    }
}

```

The example below shows two possible compilation alternatives of the code.

- Alternative 1 uses masked code and straight-forward arithmetic processing of data.
- Alternative 2 splits code to two independent unmasked flows that are processed one after another, and then a masked move (blending), just before storing to memory.

Example 18-6. Masking vs. Blending Example 1

Alternative 1	Alternative 2
<pre> mov rax, plmage mov rbx, plmage1 mov rcx, pOutImage mov rdx, len vpxord zmm0, zmm0, zmm0 mainloop: vmovdqa32 zmm2, [rax+rdx*4-0x40] vmovdqa32 zmm1, [rbx+rdx*4-0x40] vpcmpgtd k1, zmm1, zmm0 knotw k2, k1 (1) vpslld zmm2 {k1}, zmm2, 1 (2) vpsrld zmm2 {k2}, zmm2, 1 (3) vmovdqa32 [rcx+rdx*4-0x40], zmm2 sub rdx, 16 jne mainloop </pre>	<pre> mov rax, plmage mov rbx, plmage1 mov rcx, pOutImage mov rdx, len vpxord zmm0, zmm0, zmm0 mainloop: vmovdqa32 zmm2, [rax+rdx*4-0x40] vmovdqa32 zmm1, [rbx+rdx*4-0x40] vpcmpgtd k1, zmm1, zmm0 vmovdqa32 zmm3, zmm2 vpslld zmm2, zmm2, 1 vpsrld zmm3, zmm3, 1 (1) vmovdqa32 zmm3 {k1}, zmm2 (2) vmovdqa32 [rcx+rdx*4-0x40], zmm3 sub rdx, 16 jne mainloop </pre>
Baseline cycles 1x Baseline instructions 1x	Speedup: 1.23x Instructions: 1.11x

In Alternative 1, there is a dependency between instructions (1) and (2), and (2) and (3). That means that instruction (2) has to wait for the result of the blending of instruction (1), before starting execution, and instruction (3) needs to wait for instruction (2).

In Alternative 2, there is only one such dependency because each branch of conditional code is executed in parallel on all the data, and a mask is used for blending back to one register only before writing data back to the memory.

Blending is faster, but it does not mask exceptions, which may occur on the unmasked data.

Alternative 2 executes 11% more instructions; it provides 23% speedup in overall execution. Alternative 2 uses an extra register (zmm3). This extra register usage may cause extra latency in case of register pressure (freeing register to memory and loading it afterwards).

The following code is another example of masking vs. blending.

```

for (int i = 0; i < len; i++) {
    if (a[i] > b[i]) {
        a[i] += b[i];
    }
}

```

Example 18-7. Masking vs. Blending Example 2

Alternative 1	Alternative 2
<pre> mov rax,a mov rbx,b mov rdx,size2 loop1: vmovdqa32 zmm1,[rax +rdx*4 -0x40] vmovdqa32 zmm2,[rbx +rdx*4 -0x40] (1) vpcmpgtd k1,zmm1,zmm2 (2) vmovdqa32 zmm3{k1}{z},zmm2 (3) vpaddd zmm1,zmm1,zmm3 vmovdqa32 [rax +rdx*4 -0x40],zmm1 sub rdx,16 jne loop1 </pre>	<pre> mov rax,a mov rbx,b mov rdx,size2 loop1: vmovdqa32 zmm1,[rax +rdx*4 -0x40] vmovdqa32 zmm2,[rbx +rdx*4 -0x40] (1)vpcmpgtd k1,zmm1,zmm2 (2)vpaddd zmm1{k1},zmm1,zmm2 vmovdqa32 [rax +rdx*4 -0x40],zmm1 sub rdx,16 jne loop1 </pre>
<pre> Baseline cycles 1x Baseline instructions 1x </pre>	<pre> Speedup: 1.05x Instructions: 0.87x </pre>

In Alternative 1, there is a dependency between instructions (1) and (2), and (2) and (3).

In Alternative 2, there are only 2 instructions in the dependency chain: (1) and (2).

18.2.4 Nested Conditions / Mask Aggregation

Intel AVX-512 contains a set of instructions for mask operation, which enable executing all bitwise logical operators on a mask register, facilitating implementation of nested and/or multiply conditions.

In the following example, logical and (&&) is executed using a *kandw* instruction.

```

for(int iX = 0; iX < iBufferWidth; iX++)
{
    if ((*pInImage)>0 && ((*pInImage)&3)==3)
    {
        *pRefImage = (*pInImage)+5;
    }
    else
    {
        *pRefImage = (*pInImage);
    }

    pRefImage++;
    pInImage++;
}

```

Example 18-8. Multiple Condition Execution

Scalar	Intel® AVX2	Intel® AVX-512
<pre> mov rsi, plmage mov rdi, pOutImage mov rbx, len xor rax, rax mainloop: mov r8d, dword ptr [rsi+rax*4] mov r9d, r8d cmp r8d, 0 jle label1 and r9d, 0x3 cmp r9d, 3 jne label1 add r8d, 5 label1: mov dword ptr [rdi+rax*4], r8d add rax, 1 cmp rax, rbx jne mainloop </pre>	<pre> mov rsi, plmage mov rdi, pOutImage mov rbx, len xor rax, rax vpbroadcastd ymm1, [five] vpbroadcastd ymm7, [three] vpxor ymm3, ymm3, ymm3 mainloop: vmovdqd ymm0, [rsi+rax*4] vmovaps ymm6, ymm0 vpcmpgtd ymm5, ymm0, ymm3 vpand ymm6, ymm6, ymm7 vpcmpq ymm6, ymm6, ymm7 vpand ymm5, ymm5, ymm6 vpadd ymm4, ymm0, ymm1 vblendvps ymm4, ymm0, ymm4, ymm5 vmovdqd [rdi+rax*4], ymm4 add rax, 8 cmp rax, rbx jne mainloop </pre>	<pre> mov rsi, plmage mov rdi, pOutImage mov rbx, len xor rax, rax vpbroadcastd zmm1, [five] vpbroadcastd zmm5, [three] vpxord zmm3, zmm3, zmm3 mainloop: vmovdq32 zmm0, [rsi+rax*4] vpcmpgtd k1, zmm0, zmm3 vpandd zmm6, zmm5, zmm0 vpcmpq k2, zmm6, zmm5 kandw k1, k2, k1 vpadd zmm0 {k1}, zmm0, zmm1 vmovdq32 [rdi+rax*4], zmm0 add rax, 16 cmp rax, rbx jne mainloop </pre>
Baseline 1x	Speedup: 5x	Speedup: 11x

18.2.5 Memory Masking Microarchitecture Improvements

Masking improvements since Broadwell microarchitecture are detailed below.

Table 18-1. Cache Comparison Between Skylake Server Microarchitecture and Broadwell Microarchitecture

Item	Broadwell Microarchitecture	Skylake Server Microarchitecture
1	The address of a vmaskmov store is considered as resolved only after the mask is known. Loads that follow a masked store may be blocked, depending on the memory disambiguation predictor, until the mask value is known.	This issue is resolved. The address of a vmaskmov store can be resolved before the mask is known.
2	If the mask is not all 1 or all 0, loads that depend on the masked store must wait until the store data is written to the cache. If the mask is all 1 the data can be forwarded from the masked store to the dependent loads. If the mask is all 0 the loads do not depend on the masked store.	If the mask is not all 1 or all 0, loads that depend on the masked store must wait until the store data is written to the cache. If the mask is all 1 the data can be forwarded from the masked store to the dependent loads. If the mask is all 0 the loads do not depend on the masked store.
3	When including an illegal memory address range with masked loads (using the vmaskmov instruction), the processor might take a multi-cycle “assist” to determine if any part of the illegal range has a one mask value. This assist might occur even when the mask was “all-zero” and it seemed obvious to the programmer that the load should not be executed.	For Intel AVX-512 masking, if the mask is all-zeros then memory faults will be ignored and no assist will be issued.

18.2.6 Peeling and Remainder Masking

Accessing cache line aligned data gives better performance than accessing non-aligned data. In many cases, the address is not known in compile time, or known and not-aligned. In these cases a peeling algorithm may be proposed, to process first elements in masked mode, up to first aligned address, and then process unmasked body and masked remainder. This method increases code size, but improves data processing overall.

The following code is an example of peeling and remainder masking.

```
for (size_t i = 0; i < len; i++)
    pOutImage[i] = (pInImage[i] * alfa) + add_value;
```

The table below shows the difference in implementation and execution speed of two versions of the code, both working on unaligned output data array.

Example 18-9. Peeling and Remainder Masking

No peeling, unmasked body, masked remainder	Peeling, unmasked body, masked remainder
<pre>mov rbx, pOutImage // Output mov rax, plmage // Input mov rcx, len mov edx, addValue vpbroadcastd zmm0, edx mov edx, alfa vpbroadcastd zmm3, edx mov rdx, rcx sar rdx, 4 // 16 elements per iteration, RDX - number of full iterations jz remainder // no full iterations xor r8, r8 vmovups zmm10, [indices] mainloop: vmovups zmm1, [rax + r8] vfmadd213ps zmm1, zmm3, zmm0 vmovups [rbx + r8], zmm1 add r8, 0x40 sub rdx, 1 jne mainloop remainder: // produce mask for remainder and rcx, 0xF // number of elements in remainder jz end // no elements in remainder vpbroadcastd zmm2, ecx vpcmpd k2, zmm10, zmm2, 1 //compare lower vmovups zmm1 {k2}{z}, [rax + r8] vfmadd213ps zmm1 {k2}{z}, zmm3, zmm0 vmovups [rbx + r8] {k2}, zmm1 end:</pre>	<pre>mov rax, plmage // Input mov rbx, pOutImage // Output mov rcx, len movss xmm0, addValue vpbroadcastd zmm0, xmm0 movss xmm1, alfa vpbroadcastd zmm3, xmm1 xor r8, r8 xor r9, r9 vmovups zmm10, [indices] vpbroadcastd zmm12, ecx peeling: mov rdx, rbx and rdx, 0x3F jz endofpeeling //nothing to peel neg rdx add rdx, 64 // 64 - X // now rdx contains the number of bytes to the closest alignment mov r9, rdx sar r9, 2 // now r9 contains number of elements in peeling vpbroadcastd zmm12, r9d vpcmpd k2, zmm10, zmm12, 1 //compare lower to produce mask for peeling vmovups zmm1 {k2}{z}, [rax] vfmadd213ps zmm1 {k2}{z}, zmm3, zmm0 vmovups [rbx] {k2}, zmm1 //unaligned store endofpeeling: sub rcx, r9 mov r8, rcx sar r8, 4 //number of full iterations jz remainder //no full iterations</pre>

Example 18-9. Peeling and Remainder Masking (Contd.)

	<pre> mainloop: vmovups zmm1, [rax + rdx] vfmadd213ps zmm1, zmm3, zmm0 vmovaps [rbx + rdx], zmm1 // aligned store is safe here !! add rdx, 0x40 sub r8, 1 jne mainloop remainder: // produce mask for remainder and rcx, 0xF // number of elements in remainder jz end // no elements in remainder vpbroadcastd zmm2, ecx vpcmpd k2, zmm10, zmm2, 1 //compare lower vmovups zmm1 {k2}{z}, [rax + rdx] vfmadd213ps zmm1 {k2}{z}, zmm3, zmm0 vmovaps [rbx + rdx] {k2}, zmm1 //aligned end: </pre>
Baseline 1x	Speedup: 1.04x

18.3 FORWARDING AND UNMASKED OPERATIONS

When using an unmasked store instruction, and load instruction after it, data forwarding depends on load type, size and address offset from store address, and does not depend on the store address itself (i.e., the store address does not have to be aligned to or fit into cache line, forwarding will occur for non-aligned and even line-split stores).

The figure below describes all possible cases when data forwarding will occur.

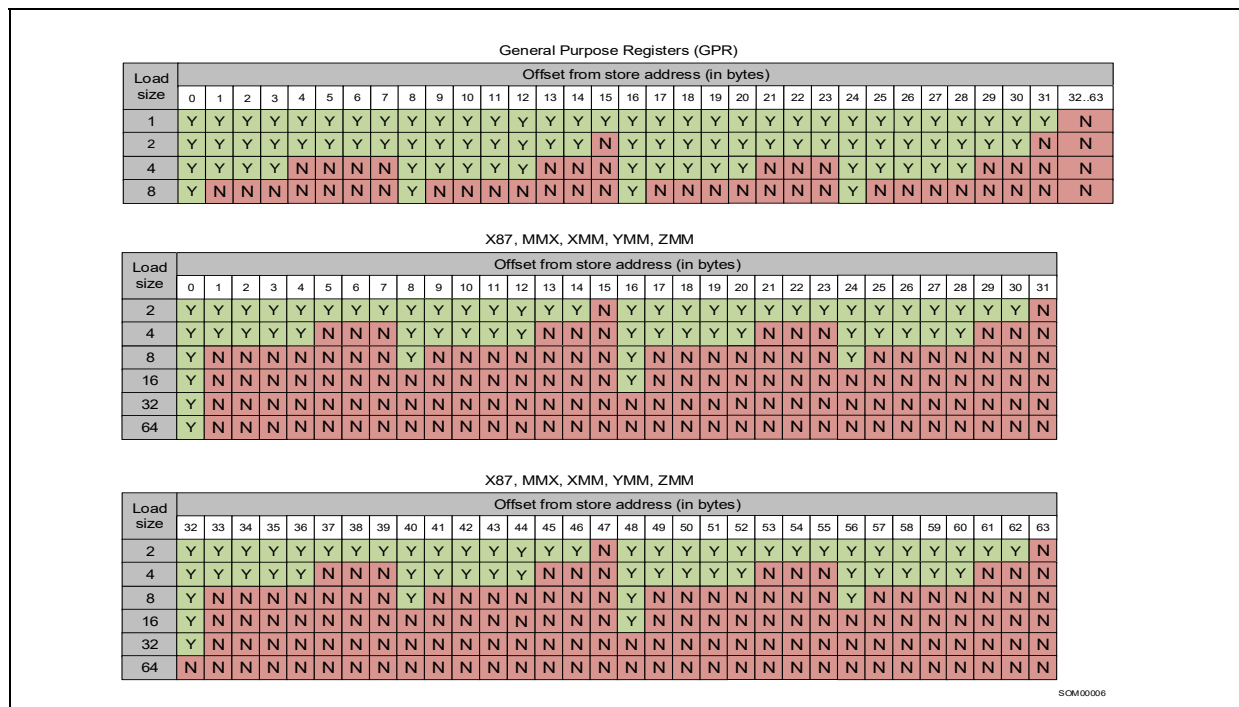

Figure 18-3. Data Forwarding Cases

There are two important points to be considered when using data forwarding.

1. Data forwarding to GPR is possible only from the lower 256 bits of store instruction. Note this when loading GPR with data that has recently been written.
2. Do not use masks, as forwarding is supported only for certain masks.

18.4 FORWARDING AND MEMORY MASKING

When using masked store and load, consider the following:

- When the mask is not all-ones or all-zeroes, the load operation, following the masked store operation from the same address is blocked, until the data is written to the cache.
- Unlike GPR forwarding rules, vector loads whether or not they are masked, do not forward unless load and store addresses are exactly the same.
 - st_mask = 10101010, ld_mask = 01010101, can forward: no, should block: yes
 - st_mask = 00001111, ld_mask = 00000011, can forward: no, should block: yes
- When the mask is all-ones, blocking does not occur, because the data may be forwarded to the load operation.
 - st_mask = 11111111, ld_mask = don't care, can forward: yes, should block: no
- When mask is all-zeroes, blocking does not occur, though neither does forwarding.
 - st_mask = 00000000, ld_mask = don't care, can forward: no, should block: no

In summary, a masked store should be used carefully, for example, if the remainder size is known at compile time to be 1, and there is a load operation from the same cache line after it (or there is an overlap in addresses + vector lengths), it may be better to use scalar remainder processing, rather than a masked remainder block.

18.5 DATA COMPRESS

The data compress operation reads elements from an input buffer on indices specified by mask register 1's bits. The elements which have been read, are then written to the destination buffer. If the number of elements is less than the destination register size, the rest of the space is filled with zeroes.

The following figure describes the data compress operation.

```
if (k[i] == 1)
{
    dest[a] = src[i];
    a++;
}
```

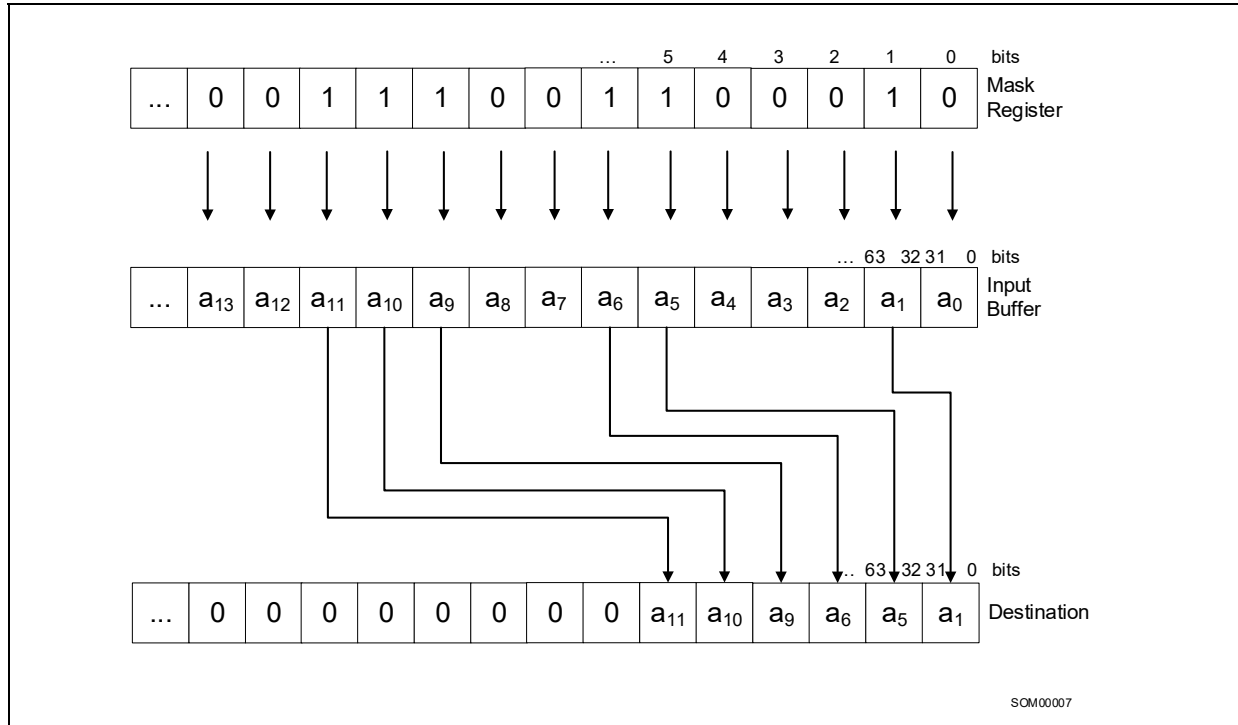

Figure 18-4. Data Compress Operation

18.5.1 Data Compress Example

The following snippet shows collection of all positive elements from one array to another array.

```
for (int i=0; i<SIZE; i++)
{
    if ( a[i] > 0 )
        b[j++] = a[i];
}
```

Following are four implementations for the compress operation from an array of dword elements.

- Alternative 1 uses scalar data access and checks each element separately. If it is greater than 0 it is written to the destination array.
- Alternative 2 is Intel AVX code that uses a shuffle instruction together with the pre-allocated and pre-initialized table with shuffle keys. The compare instruction provides the entry point number to the shuffle-key table. Then the key is loaded and the original array is shuffled according to the keys. Four elements are processed in each iteration.
- Alternative 3 uses the same algorithm as in Alternative 2, but uses Intel AVX2 256-bit registers, and a permutation on the dword instruction instead of using byte shuffle. Eight elements are processed in each iteration.
- Alternative 4 is an Intel AVX-512 algorithm, which uses the *vpcompress* instruction together with the mask register as a compress key. 16 elements are processed in each iteration.

Example 18-10. Comparing Intel® AVX-512 Data Compress with Other Alternatives

Alternative 1: Scalar
<pre> mov rsi, source mov rdi, dest mov r9, len xor r8, r8 xor r10, r10 mainloop: mov r11d, dword ptr [rsi+r8*4] test r11d, r11d jle m1 mov dword ptr [rdi+r10*4], r11d inc r10 m1: inc r8 cmp r8, r9 jne mainloop </pre>
Baseline 1x

Example 18-10. Comparing Intel® AVX-512 Data Compress with Other Alternatives (Contd.)

Alternative 2: Intel® AVX
<pre> mov rsi, source mov rdi, dest mov r14, shuffle_LUT mov r15, write_mask mov r9, len xor r8, r8 xor r11, r11 vpxor xmm0, xmm0, xmm0 mainloop: vmovdqa xmm1, [rsi+r8*4] vpcmpgtd xmm2, xmm1, xmm0 mov r10, 4 vmovmskps r13, xmm2 shl r13, 4 vmovdqu xmm3, [r14+r13] vpshufb xmm2, xmm1, xmm3 popcnt r13, r13 sub r10, r13 vmovdqu xmm3, [r15+r10*4] vmaskmovps [rdi+r11*4], xmm3, xmm2 add r11, r13 add r8, 4 cmp r8, r9 jne mainloop shuffle_LUT: .int 0x80808080, 0x80808080, 0x80808080, 0x80808080 .int 0x03020100, 0x80808080, 0x80808080, 0x80808080 .int 0x07060504, 0x80808080, 0x80808080, 0x80808080 .int 0x03020100, 0x07060504, 0x80808080, 0x80808080 .int 0x0b0A0908, 0x80808080, 0x80808080, 0x80808080 .int 0x03020100, 0x0b0A0908, 0x80808080, 0x80808080 .int 0x07060504, 0x0b0A0908, 0x80808080, 0x80808080 .int 0x03020100, 0x07060504, 0x0b0A0908, 0x80808080 .int 0x0F0E0D0C, 0x80808080, 0x80808080, 0x80808080 .int 0x03020100, 0x0F0E0D0C, 0x80808080, 0x80808080 .int 0x07060504, 0x0F0E0D0C, 0x80808080, 0x80808080 .int 0x03020100, 0x07060504, 0x0F0E0D0C, 0x80808080 .int 0x0b0A0908, 0x0F0E0D0C, 0x80808080, 0x80808080 .int 0x03020100, 0x0b0A0908, 0x0F0E0D0C, 0x80808080 .int 0x07060504, 0x0b0A0908, 0x0F0E0D0C, 0x80808080 .int 0x03020100, 0x07060504, 0x0b0A0908, 0x0F0E0D0C write_mask: .int 0x80000000, 0x80000000, 0x80000000, 0x80000000 .int 0x00000000, 0x00000000, 0x00000000, 0x00000000 </pre>
Speedup: 2.87x

Example 18-10. Comparing Intel® AVX-512 Data Compress with Other Alternatives (Contd.)**Alternative 3: Intel® AVX2**

```

mov rsi, source
mov rdi, dest
mov r14, shuffle_LUT
mov r15, write_mask
mov r9, len

xor r8, r8
xor r11, r11
vpxor ymm0, ymm0, ymm0
mainloop:
vmovdqa ymm1, [rsi+r8*4]
vpcmpgtd ymm2, ymm1, ymm0
mov r10, 8
vmovmskps r13, ymm2
shl r13, 5
vmovdqu ymm3, [r14+r13]
vpermd ymm2, ymm3, ymm1
popcnt r13, r13
sub r10, r13
vmovdqu ymm3, [r15+r10*4]
vmaskmovps [rdi+r11*4], ymm3, ymm2
add r11, r13
add r8, 8
cmp r8, r9
jne mainloop

```

// The lookup table is too large to reproduce in the document. It consists of 256 rows of 8 32 bit integers.
//The first 8 and the last 8 rows are shown below.

```

shuffle_LUT:
.int 0x0, 0x0, 0x0, 0x0, 0x0, 0x0, 0x0, 0x0
.int 0x0, 0x0, 0x0, 0x0, 0x0, 0x0, 0x0, 0x0
.int 0x1, 0x0, 0x0, 0x0, 0x0, 0x0, 0x0, 0x0
.int 0x0, 0x1, 0x0, 0x0, 0x0, 0x0, 0x0, 0x0
.int 0x2, 0x0, 0x0, 0x0, 0x0, 0x0, 0x0, 0x0
.int 0x0, 0x2, 0x0, 0x0, 0x0, 0x0, 0x0, 0x0
.int 0x1, 0x2, 0x0, 0x0, 0x0, 0x0, 0x0, 0x0
.int 0x0, 0x1, 0x2, 0x0, 0x0, 0x0, 0x0, 0x0
// Skipping 240 lines
.int 0x3, 0x4, 0x5, 0x6, 0x7, 0x0, 0x0, 0x0
.int 0x0, 0x3, 0x4, 0x5, 0x6, 0x7, 0x0, 0x0
.int 0x1, 0x3, 0x4, 0x5, 0x6, 0x7, 0x0, 0x0
.int 0x0, 0x1, 0x3, 0x4, 0x5, 0x6, 0x7, 0x0
.int 0x2, 0x3, 0x4, 0x5, 0x6, 0x7, 0x0, 0x0
.int 0x0, 0x2, 0x3, 0x4, 0x5, 0x6, 0x7, 0x0
.int 0x1, 0x2, 0x3, 0x4, 0x5, 0x6, 0x7, 0x0
.int 0x0, 0x1, 0x2, 0x3, 0x4, 0x5, 0x6, 0x7

```

Example 18-10. Comparing Intel® AVX-512 Data Compress with Other Alternatives (Contd.)

<pre> write_mask: .int 0x80000000, 0x80000000, 0x80000000, 0x80000000 .int 0x80000000, 0x80000000, 0x80000000, 0x80000000 .int 0x00000000, 0x00000000, 0x00000000, 0x00000000 .int 0x00000000, 0x00000000, 0x00000000, 0x00000000 </pre>
Speedup: 5.27x
Alternative 4: Intel® AVX-512
<pre> mov rsi, source mov rdi, dest mov r9, len xor r8, r8 xor r10, r10 vpxord zmm0, zmm0, zmm0 mainloop: vmovdqa32 zmm1, [rsi+r8*4] vpcmpgtd k1, zmm1, zmm0 vpcompressd zmm2 {k1}, zmm1 vmovdqu32 [rdi+r10*4], zmm2 kmovd r11d, k1 popcnt r12, r11 add r8, 16 add r10, r12 cmp r8, r9 jne mainloop </pre>
Speedup: 11.9x

18.6 DATA EXPAND

Data expand operations read elements from the source array (register) and put them in the destination register in the places indicated by enabled bits in the mask register. If the number of enabled bits is less than destination register size, the extra values are ignored.

```

if (k[i] == 1)
{
    dest[i] = src[a];
    a++;
}

```

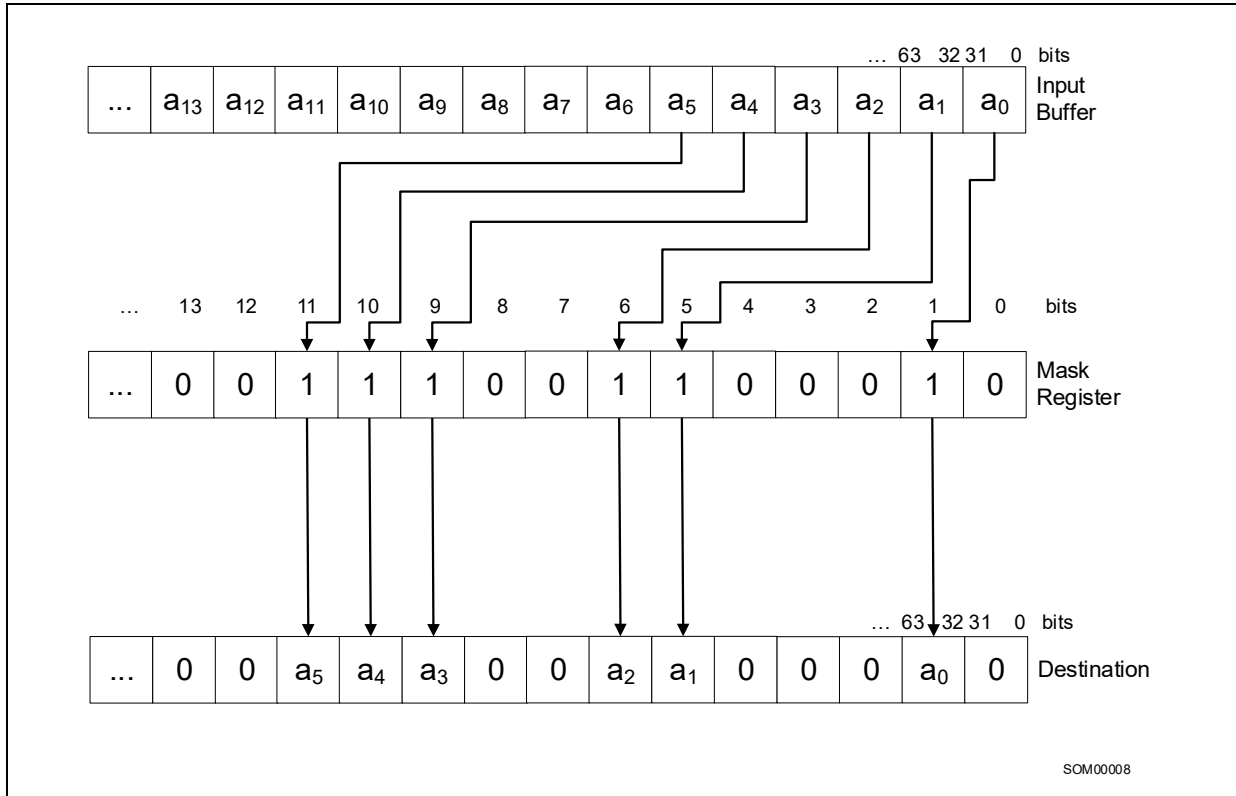



Figure 18-5. Data Expand Operation

18.6.1 Data Expand Example

The following snippet shows an example of using the expand operation. For every positive number in an array, the code sets its consecutive number among positives.

```
for (int i=0; i<SIZE; i++)
{
    if (a[i] > 0)
        dest[i] = a[count++];
    else
        dest[i] = 0;
}
```

Here are three implementations for the expand operation from an array of 16 dword elements.

- Alternative 1 uses scalar data access and checks each element separately. If it is greater than 0 then the corresponding element in the destination array is rewritten with the value from source value at index count, and the counter is incremented.
- Alternative 2 shows Intel AVX2 code that uses a shuffle instruction together with the pre-allocated and pre-initialized table with shuffle keys. The compare instruction provides the entry point number to the shuffle-key table. Then the key is loaded and the original array is shuffled according to the keys. Four elements are processed in each iteration.
- Alternative 3 shows Intel AVX-512 code, which uses the *vpexpandd* instruction together with the mask register as an expand key. 16 elements are processed in each iteration.

Example 18-11. Comparing Intel® AVX-512 Data Expand Operation with Other Alternatives

Alternative 1: Scalar	Alternative 2: Intel® AVX2 Code	Alternative 3: Intel® AVX-512 Code
<pre> mov rsi, input mov rdi, output mov r9, len xor r8, r8 xor r10, r10 mainloop: mov r11d, dword ptr [rsi+r8*4] test r11d, r11d jle m1 mov r11d, dword ptr [rsi+r10*4] mov dword ptr [rdi+r8*4], r11d inc r10 m1: inc r8 cmp r8, r9 jne mainloop </pre>	<pre> mov rsi, input mov rdi, output mov r9, len xor r8, r8 xor r10, r10 vpxor ymm0, ymm0, ymm0 mov r14, shuf2 mainloop: vmovdqa ymm1, [rsi+r8*4] vpxor ymm4, ymm4, ymm4 vpcmpgtd ymm2, ymm1, ymm0 vmovdqu ymm1, [rsi+r10*4] vmovmskps r13, ymm2 shl r13, 5 vmovdqa ymm3, [r14+r13] vpermd ymm4, ymm3, ymm1 popcnt r13, r13 add r10, r13 vmaskmovps [rdi+r8*4], ymm2, ymm4 add r8, 8 cmp r8, r9 jne mainloop </pre> <p>// The lookup table is too large to // reproduce in the document. It consists // of 256 rows of 8 32-bit integers. The // first 8 and the last 8 rows are shown // below. The table needs to be 32-byte // aligned.</p> <pre> shuf2: .int 0, 0, 0, 0, 0, 0, 0, 0 .int 0, 0, 0, 0, 0, 0, 0, 0 .int 0, 0, 0, 0, 0, 0, 0, 0 .int 0, 1, 0, 0, 0, 0, 0, 0 .int 0, 0, 0, 0, 0, 0, 0, 0 .int 0, 0, 1, 0, 0, 0, 0, 0 .int 0, 0, 1, 0, 0, 0, 0, 0 .int 0, 1, 2, 0, 0, 0, 0, 0 // Skipping 240 lines .int 0, 0, 0, 0, 1, 2, 3, 4 .int 0, 0, 0, 0, 1, 2, 3, 4, 5 .int 0, 0, 0, 0, 1, 2, 3, 4, 5 .int 0, 1, 0, 2, 3, 4, 5, 6 .int 0, 0, 0, 1, 2, 3, 4, 5 .int 0, 0, 1, 2, 3, 4, 5, 6 .int 0, 0, 1, 2, 3, 4, 5, 6 .int 0, 1, 2, 3, 4, 5, 6, 7 </pre>	<pre> vpxord zmm0, zmm0, zmm0 mainloop: vmovdqa32 zmm1, [rsi+r8*4] vpcmpgtd k1, zmm1, zmm0 vmovdqu32 zmm1, [rsi+r10*4] vpexpandd zmm2 {k1}{z}, zmm1 vmovdqu32 [rdi+r8*4], zmm2 add r8, 16 kmovd r11d, k1 popcnt r12, r11 add r10, r12 cmp r8, r9 jne mainloop </pre>
Baseline 1x	Speedup: 4.23x	Speedup: 8.58x

18.7 TERNARY LOGIC

A ternary logic *vpternlog* operation executes any bitwise logical function between three operands in one instruction. The instruction requires three operands and an immediate value, which is the truth table of this logical expression. The first operand is used as destination, and, therefore, destroyed after the execution.

18.7.1 Ternary Logic Example 1

The following example shows a bitwise logic function of three variables. The function in this example is defined by the following truth table.

X	1	1	1	1	0	0	0	0	<div style="border: 1px solid black; padding: 5px; width: fit-content;"> Immediate value that is used. </div> <div style="border: 1px solid black; padding: 5px; width: fit-content; margin-top: 5px;"> 0x92 </div>
Y	1	1	0	0	1	1	0	0	
Z	1	0	1	0	1	0	1	0	
f(X, Y, Z)	1	0	0	1	0	0	1	0	

SOM00009

Figure 18-6. Ternary Logic Example 1 Truth Table

Using Karnaugh maps on this truth table, we can define the function as:

$$f(X,Y,Z) = \bar{x} \bar{y} z \vee xyz \vee x \bar{y} \bar{z}$$

or, in shorter notation, using fewer binary operations:

$$f(X,Y,Z) = \bar{y}(z \oplus x) \vee xyz$$

The C code for the function above is as follows:

```
for (int i=0; i<SIZE; i++)
{
    Dst[i] = ((~Src2[i]) & (Src1[i] ^ Src3[i])) | (Src1[i] & Src2[i] & Src3[i]);
}
```

The value of the function for each combination of X, Y and Z gives an immediate value that is used in the instruction.

Here are three implementations for this logical function applied to all values in X, Y and Z arrays.

- Alternative 1 is an Intel AVX2 256-bit vector computation, using bitwise logical functions available in Intel AVX2.
- Alternative 2 is a 512-bit vector computation, using bitwise logical functions available in Intel AVX-512, without using the *vpternlog* instruction.
- Alternative 3 is an Intel AVX-512 512-bit vector computation, using the *vpternlog* instruction.

All alternatives in the table are unrolled by factor 2.

Example 18-12. Comparing Ternary Logic to Other Alternatives

Alternative 1: Intel® AVX2
<pre> mov rax, src1 mov rbx, src2 mov rcx, src3 mov r11, dst mov r8, len xor r10, r10 mainloop: vmovdqu ymm1, ymmword ptr [rax+r10*4] vmovdqu ymm3, ymmword ptr [rdx+r10*4] vmovdqu ymm2, ymmword ptr [rcx+r10*4] vmovdqu ymm10, ymmword ptr [rcx+r10*4+0x20] vpand ymm0, ymm1, ymm3 vpxor ymm4, ymm1, ymm2 vpand ymm5, ymm0, ymm2 vpandn ymm6, ymm3, ymm4 vpor ymm7, ymm5, ymm6 vmovdqu ymmword ptr [r11+r10*4], ymm7 vmovdqu ymm9, ymmword ptr [rax+r10*4+0x20] vmovdqu ymm11, ymmword ptr [rdx+r10*4+0x20] vpxor ymm12, ymm9, ymm10 vpand ymm8, ymm9, ymm11 vpandn ymm14, ymm11, ymm12 vpand ymm13, ymm8, ymm10 vpor ymm15, ymm13, ymm14 vmovdqu ymmword ptr [r11+r10*4+0x20], ymm15 </pre>
<pre> add r10, 0x10 cmp r10, r8 jb mainloop </pre>
Baseline 1x

Example 18-12. Comparing Ternary Logic to Other Alternatives (Contd.)

Alternative 2: Intel® AVX-512 Logic Instructions	Alternative 3: Intel® AVX-512 using <i>vpternlog</i> Instruction
<pre> mov rdi, src1 mov rsi, src2 mov rdx, src3 mov r11, dst mov r8, len xor r10, r10 mainloop: vmovups zmm2, zmmword ptr [rdi+r10*4] vmovups zmm4, zmmword ptr [rdi+r10*4+0x40] vmovups zmm6, zmmword ptr [rsi+r10*4] vmovups zmm8, zmmword ptr [rsi+r10*4+0x40] vmovups zmm3, zmmword ptr [rdx+r10*4] vmovups zmm5, zmmword ptr [rdx+r10*4+0x40] vpandd zmm0, zmm2, zmm6 vpandd zmm1, zmm4, zmm8 vpxord zmm7, zmm2, zmm3 vpxord zmm9, zmm4, zmm5 vpandd zmm10, zmm0, zmm3 vpandd zmm12, zmm1, zmm5 vpandnd zmm11, zmm6, zmm7 vpandnd zmm13, zmm8, zmm9 vpord zmm14, zmm10, zmm11 vpord zmm15, zmm12, zmm13 vmovups zmmword ptr [r11+r10*4], zmm14 vmovups zmmword ptr [r11+r10*4+0x40], zmm15 add r10, 0x20 cmp r10, r9 jb mainloop </pre>	<pre> mov r9, src1 mov r8, src2 mov r10, src3 mov r11, dst mov rsi, len xor rax, rax mainloop: vmovaps zmm1, [r8+rax*4] vmovaps zmm0, [r9+rax*4] vpternlogd zmm0, zmm1, [r10], 0x92 vmovaps [r11], zmm0 vmovaps zmm1, [r8+rax*4+0x40] vmovaps zmm0, [r9+rax*4+0x40] vpternlogd zmm0, zmm1, [r10+0x40], 0x92 vmovaps [r11+0x40], zmm0 add rax, 32 add r10, 0x80 add r11, 0x80 cmp rax, rsi jne mainloop </pre>
Speedup: 1.94x	Speedup: 2.36x (1.22x vs Intel® AVX-512 with logic instructions)

18.7.2 Ternary Logic Example 2

The next example is a sign change operation, frequently used in Fortran. Consider the following code, running on two arrays of floating point numbers.

```

for (int i=0; i<SIZE; i++)
{
    b[i] = a[i] > 0 ? b[i] : -b[i];
}

```

This code is equivalent to:

```
for (int i=0; i<SIZE; i++)
{
    b[i] = ( a[i] & 0x80000000 ) ^ b[i];
}
```

Or, in other words:

$$x = (y \wedge z) \oplus x$$

This logic expression gives the following truth table.

X	1	1	1	1	0	0	0	0	<div style="border: 1px solid black; padding: 5px; width: fit-content;"> Immediate value that is used in the vpternlog instruction. </div> <div style="border: 1px solid black; padding: 5px; width: fit-content; margin-top: 5px;"> 0x78 </div>
Y	1	1	0	0	1	1	0	0	
Z	1	0	1	0	1	0	1	0	
f(X, Y, Z)	0	1	1	1	1	0	0	0	

SOM00010

Figure 18-7. Ternary Logic Example 2 Truth Table

Therefore one *vpternlog* instruction can be used instead of using two logic instructions (*vpand* and *vpxor*):

```
vpternlog x, y, z, 0x78
```

18.8 NEW SHUFFLE INSTRUCTIONS

Intel AVX-512 added 3 new shuffle operations.

- *vpermw*: a new single source any-to-any word permute.
- *permt2[w/d/q/ps/pd]*: a new any to any 2 source permute (overriding src register).
- *permi2[w/d/q/ps/pd]*: a new any to any 2 source permute (overriding control register).

The following figure shows how *vpermi2ps* is used. Notice that in the following example *zmm0* is the shuffle control but also the output register (the control register is overridden).

```
vpermi2ps zmm0, zmm1, zmm2
```

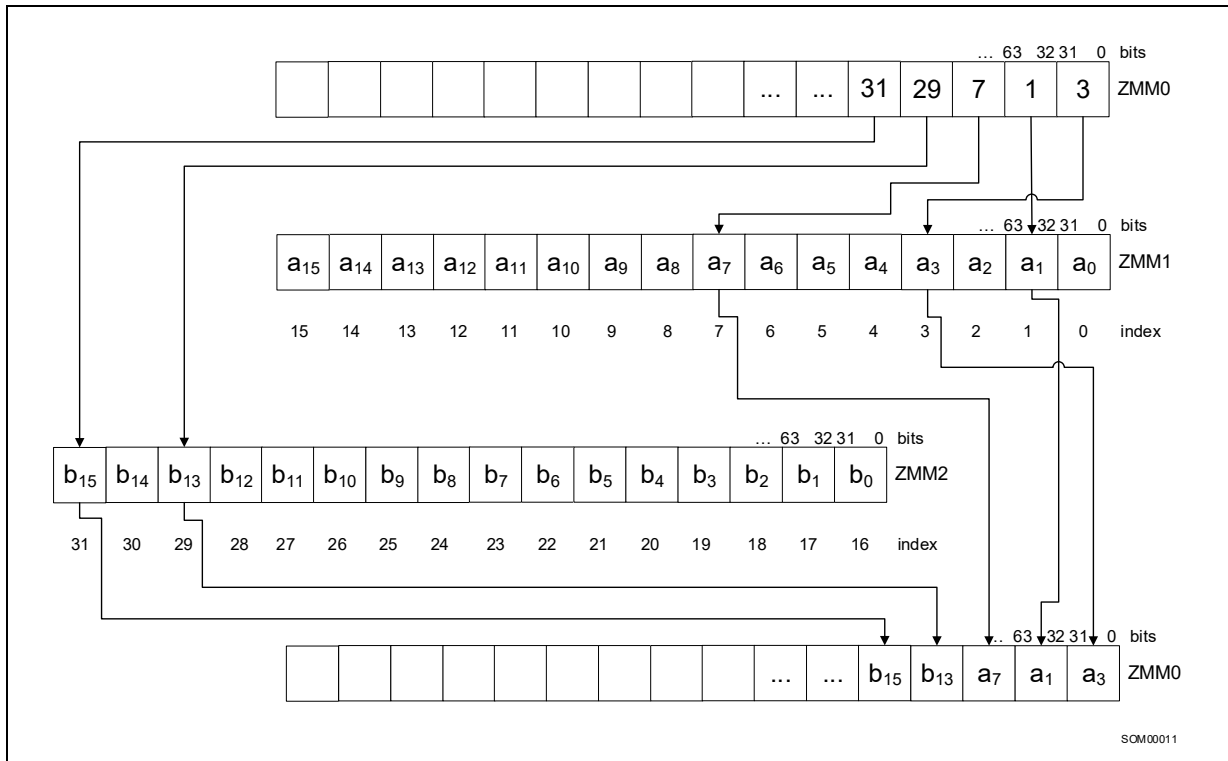

Figure 18-8. VPERM2PS Instruction Operation

Note that the index register values must have the same resolution as the instruction and source registers (word when working on words, dword when working on dwords, etc.).

18.8.1 Two Source Permute Example

In this example we will show the use of the two source permute instructions in a matrix transpose operation. The matrix we want to transpose is square 8x8 matrix of word elements.



The corresponding C code is as follows (assuming each matrix occupies a continuous block of $8 \times 8 \times 2 = 128$ bytes):

```

    for(int iY = 0; iY < 8; iY++)
    {
        for(int iX = 0; iX < 8; iX++)
        {
            trasposedMatrix[iY*8+iX] = originalMatrix[iX*8+iY];
        }
    }

```

Here are three implementations for this matrix transpose.

- Alternative 1 is scalar code, which accesses each element of the source matrix and puts it to the corresponding place in the destination matrix. This code does 64 (8×8) iterations per 1 matrix.
- Alternative 2 is Intel AVX2 code, which uses Intel AVX2 permutation and shuffle (unpack) instructions. Only 1 iteration per 8×8 matrix is required.
- Alternative 3 Intel AVX-512 code which uses the Two Source Permutation instructions. Note that this code first loads permutation masks, and then matrix data. The mask used to perform the permutation is stored in the following array:

```

short permMaskBuffer [8*8] = { 0, 8, 16, 24, 32, 40, 48, 56,
                               1, 9, 17, 25, 33, 41, 49, 57,
                               2, 10, 18, 26, 34, 42, 50, 58,
                               3, 11, 19, 27, 35, 43, 51, 59,
                               4, 12, 20, 28, 36, 44, 52, 60,
                               5, 13, 21, 29, 37, 45, 53, 61,
                               6, 14, 22, 30, 38, 46, 54, 62,
                               7, 15, 23, 31, 39, 47, 55, 63 };

```

Each alternative transposes 50 matrixes, 8×8 2-byte elements each.

Example 18-13. Matrix Transpose Alternatives

Alternative 1: Scalar code	Alternative 2: Intel® AVX2 Code	Alternative 3: Intel® AVX-512 Code
<pre> mov rsi, plmage mov rdi, pOutlImage xor rdx, rdx matrix_loop: xor rax, rax outerloop: xor rbx, rbx innerloop: mov rcx, rax shl rcx, 3 add rcx, rbx mov r8w, word ptr [rsi+rcx*2] mov rcx, rbx shl rcx, 3 add rcx, rax mov word ptr [rdi+rcx*2], r8w add rbx, 1 cmp rbx, 8 jne innerloop add rax, 1 cmp rax, 8 jne outerloop add rdx, 1 add rsi, 64*2 add rdi, 64*2 cmp rdx, 50 jne matrix_loop </pre>	<pre> mov rsi, plmage mov rdi, pOutlImage xor rdx, rdx matrix_loop: vmovdqa xmm0, [rsi] vmovdqa xmm1, [rsi+0x10] vmovdqa xmm2, [rsi+0x20] vmovdqa xmm3, [rsi+0x30] vinserti128 ymm0, ymm0, [rsi+0x40], 0x1 vinserti128 ymm1, ymm1, [rsi+0x50], 0x1 vinserti128 ymm2, ymm2, [rsi+0x60], 0x1 vinserti128 ymm3, ymm3, [rsi+0x70], 0x1 vpunpcklwd ymm4, ymm0, ymm1 vpunpckhwd ymm5, ymm0, ymm1 vpunpcklwd ymm6, ymm2, ymm3 vpunpckhwd ymm7, ymm2, ymm3 vpunpckldq ymm0, ymm4, ymm6 vpunpckhdq ymm1, ymm4, ymm6 vpunpckldq ymm2, ymm5, ymm7 vpunpckhdq ymm3, ymm5, ymm7 vpermq ymm0, ymm0, 0xD8 vpermq ymm1, ymm1, 0xD8 vpermq ymm2, ymm2, 0xD8 vpermq ymm3, ymm3, 0xD8 vmovdqa [rdi], ymm0 vmovdqa [rdi+0x20], ymm1 vmovdqa [rdi+0x40], ymm2 vmovdqa [rdi+0x60], ymm3 add rdx, 1 add rsi, 64*2 add rdi, 64*2 cmp rdx, 50 jne matrix_loop </pre>	<pre> mov rax, permMaskBuffer vmovdqa32 zmm10, [rax] vmovdqa32 zmm11, [rax+0x40] mov rsi, plmage mov rdi, pOutlImage xor rdx, rdx matrix_loop: vmovdqa32 zmm2, [rsi] vmovdqa32 zmm3, [rsi+0x40] vmovdqa32 zmm0, zmm10 vmovdqa32 zmm1, zmm11 vpermi2w zmm0, zmm2, zmm3 vpermi2w zmm1, zmm2, zmm3 vmovdqa32 [rdi], zmm0 vmovdqa32 [rdi+0x40], zmm1 add rdx, 1 add rsi, 64*2 add rdi, 64*2 cmp rdx, 50 jne matrix_loop </pre>
Baseline 1x	Speedup: 13.7x	Speedup: 37.3x (2.7x vs Intel® AVX2 code)

18.9 BROADCAST

18.9.1 Embedded Broadcast

Intel AVX-512 introduces embedded broadcast operations, in which a broadcast operation is implied within the syntax of a non-broadcast instruction. A source from memory can be broadcast, that is, repeated, across all the elements of the effective source operand, up to 16 times for a 32-bit data element, and up to 8 times for a 64-bit data element, without using an additional source register. This is useful when we want to reuse the same scalar operand for all the operations in a vector instruction.

Embedded broadcast is only enabled on instructions with an element size of 32 or 64 bits; however, new FP16 instructions allow embedded broadcast. Please see Section 19.4.7, “FP16 Conversions to and from Other Data Types” for more information. In the case of older technologies, byte and word element broadcasts do not support embedded broadcast. Use a broadcast instruction, rather than embedded broadcast, to broadcast a byte or word.

Using embedded broadcast can reduce the number of registers used in the code, which may be helpful when register pressure exists.

In addition, when using embedded broadcast the load micro-op is in the same instruction as the operation micro-op, and therefore can benefit from micro fusion.

For example, replace the following code:

```
vbroadcastss zmm3, [rax]
vmulps zmm1, zmm2, zmm3
```

with:

```
vmulps zmm1, zmm2, [rax] {1to16}
```

The {1to16} primitive does the following:

1. Loads one float32 (single precision) element from memory.
2. Replicates it 16 times to form a vector of 16 32-bit floating point elements.

Intel AVX-512 instructions with store semantics and pure load instructions do not support broadcast primitives.

18.9.2 Broadcast Executed on Load Ports

In Skylake Server microarchitecture, a broadcast instruction with a memory operand of 32 bits or above is executed on the load ports; it is not executed on port 5 as other shuffles are. Alternative 2 in the following example shows how executing the broadcast on the load ports reduces the workload on port 5 and increases performance. Alternative 3 shows how embedded broadcast benefits from both executing the broadcast on the load ports and micro fusion.

Example 18-14. Broadcast Executed on Load Ports Alternatives

Alternative 1: 32-bit Load and Register Broadcast	Alternative 2: Broadcast with a 32-bit Memory Operand	Alternative 3: 32-bit Embedded Broadcast
---	---	--

Example 18-14. Broadcast Executed on Load Ports Alternatives (Contd.)

<pre> loop: vmovd xmm0, [rax] vpbroadcastd zmm0, xmm0 vpaddd zmm2, zmm1, zmm0 vpermd zmm2, zmm3, zmm2 add rax, 0x4 sub rdx, 0x1 jnz loop </pre>	<pre> loop: vpbroadcastd zmm0, [rax] vpaddd zmm2, zmm1, zmm0 vpermd zmm2, zmm3, zmm2 add rax, 0x4 sub rdx, 0x1 jnz loop </pre>	<pre> loop: vpaddd zmm2, zmm1, [rax][1to16] vpermd zmm2, zmm3, zmm2 add rax, 0x4 sub rdx, 0x1 jnz loop </pre>
Baseline 1x	Speedup: 1.57x	Speedup: 1.9x

The following example shows that on Skylake Server microarchitecture, 16-bit broadcast is executed on port 5 and therefore does not gain from the memory operand broadcast.

Example 18-15. 16-bit Broadcast Executed on Port 5

Alternative 1: 16-bit Load and Register Broadcast	Alternative 2: Broadcast with a 16-bit Memory Operand
<pre> loop: vmovd xmm0, [rax] vpbroadcastw zmm0, xmm0 vpaddw zmm2, zmm1, zmm0 vpermw zmm2, zmm3, zmm2 add rax, 0x4 sub rdx, 0x1 jnz loop </pre>	<pre> loop: vpbroadcastw zmm0, [rax] vpaddw zmm2, zmm1, zmm0 vpermw zmm2, zmm3, zmm2 add rax, 0x2 sub rdx, 0x1 jnz loop </pre>
Baseline 1x	Speedup: equal to baseline

Notice that embedded broadcast is not supported for 16-bit memory operands.

18.10 EMBEDDED ROUNDING

By default, the Rounding Mode is set by bits 13:14 of the MXCSR register.

Intel AVX-512 introduces a new instruction attribute called Static (per instruction) Rounding Mode (RM) or Rounding Mode override. This attribute allows a specific arithmetic rounding mode to be applied, ignoring the value of the RM bits in the MXCSR. In combination with the rounding-mode, Intel AVX-512 also has an SAE (“suppress-all-exceptions”) attribute, to disable reporting any floating-point exception flag in the MXCSR. SAE is always implied when rounding-mode is enabled.

Static Rounding Mode and SAE control can be enabled in the encoding of the instruction by setting the EVEX.b bit to 1 in a register-register vector instruction. In this case, vector length is assumed to be the maximal possible vector length (512-bit in case of Intel AVX-512). The table below summarizes the possible static rounding-mode assignments in Intel AVX-512. Note that some instructions already allow the rounding mode to be statically specified via immediate bits. In such case, the immediate bits take precedence over the embedded rounding mode in the same way as they take precedence over the bits in MXCSR.RM

18.10.1 Static Rounding Mode

Static rounding mode functions and descriptions are listed below.

Table 18-2. Static Rounding Mode Functions

Function	Description
{rn-sae}	Round to nearest (even) + SAE
{rd-sae}	Round down (toward -infinity) + SAE
{ru-sae}	Round up (toward +infinity) + SAE
{rz-sae}	Round toward zero (Truncate) + SAE

The following code snippet shows a usage example.

Example 18-16. Embedded vs Non-embedded Rounding

Using Embedded Rounding	Without Embedded Rounding
vaddps zmm7 {k6}, zmm2, zmm4, {ru-sae}	<pre> ;rax & rcx point to temporary dword values in memory used to load and save (for restoring) MXCSR value vstmxcsr [rax] ;load mxcsr value to memory mov ebx, [rax] ;move to register and ebx, 0xFFFF9FFF ;zero RM bits or ebx, 0x5F80 ;put {ru} to RM bits and suppress all exceptions mov [rcx], ebx ;move new value to the memory vldmxcsr [rcx] ;save to MXCSR vaddps zmm7 {k6}, zmm2, zmm4 ;operation itself vldmxcsr [rax] ;restore previous MXCSR value </pre>

This piece of code would perform the single-precision floating point addition of vectors zmm2 and zmm4 with round-towards-plus-infinity, leaving the result in vector zmm7 using k6 as a conditional writemask. Note that MXCSR.RM bits are ignored and unaffected by the outcome of this instruction.

The following are examples of instructions instances where the static rounding-mode is not allowed.

```

; rounding-mode already specified in the instruction immediate
vrndscaleps zmm7 {k6}, zmm2 {rd}, 0x00

; instructions with memory operands
vmulps zmm7 {k6}, zmm2, [rax] {rd}

; instructions with vector length different than maximal vector length (512-bit)
vaddps ymm7 {k6}, ymm2, ymm4 {rd}

; non-floating point instructions
vpadd zmm7 {k6}, zmm2, zmm4 {rd}

```

18.11 SCATTER INSTRUCTION

This instruction performs a non-continuous store of data (scatter). Given a base address, a set of signed offsets and a data item, the instruction writes each element in the data register to the memory location computed from the base address and corresponding offset. The instruction stores up to 16 elements (8 elements for qword indices) in a doubleword vector or 8 elements in a quadword vector, to the memory locations pointed to by the base address and index vector. Elements are stored only if their corresponding mask bit is one. The figure below describes the following operation.

```
vscatterdpd [rax + zmm0]{k1} , zmm1
```

In this example, `rax` contains the base address, `zmm0` contains a set of offsets, and `zmm1` contains data to be written.

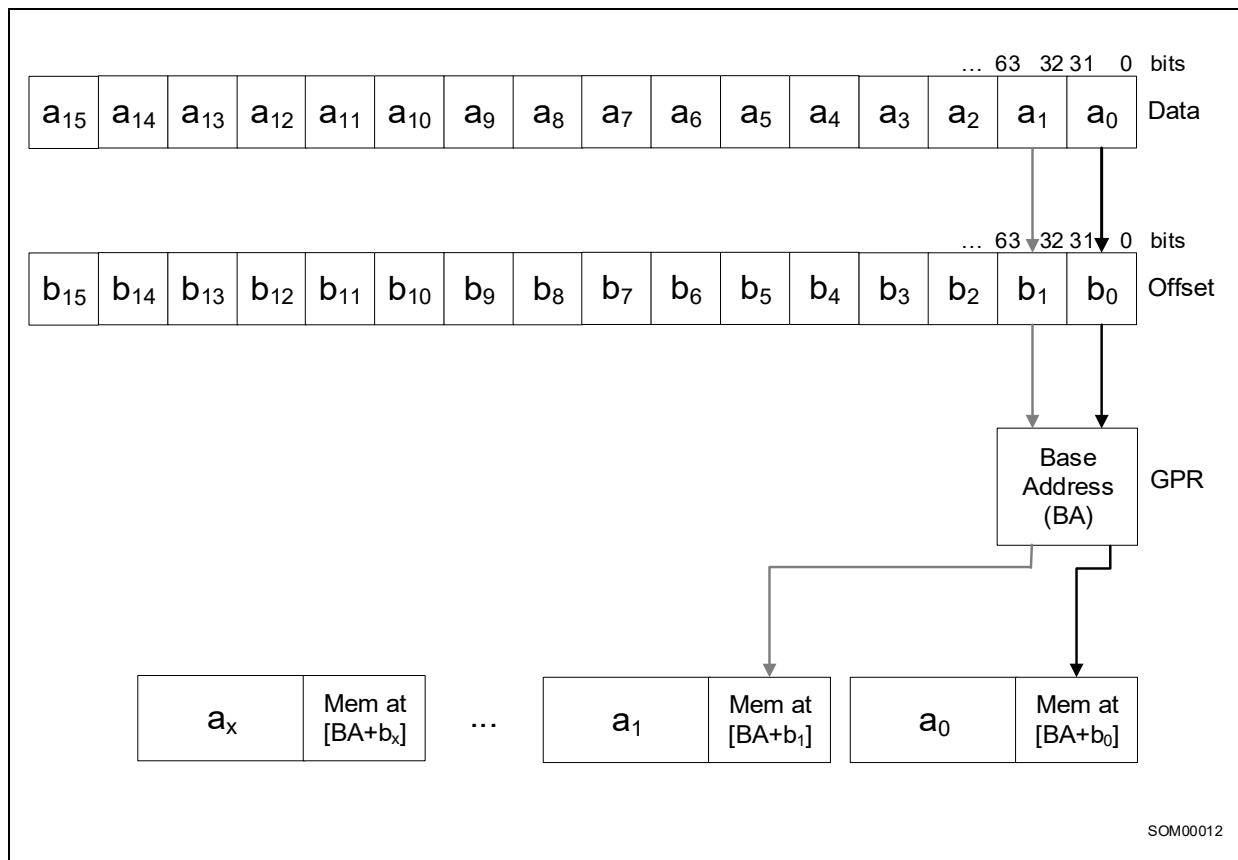

Figure 18-9. VSCATTERDPD Instruction Operation

18.11.1 Data Scatter Example

Given an array of unique indexes, ranging from 0 to N, we want to sort the array of N values, according to the corresponding index, while converting the values from long long integers (64 bits) to floating point numbers (32 bits).

```
for ( int i=0; i < N; i++ )
{
    dst[ ind [i] ] = (float)src[i];
}
```

Here are three implementations of the code above.

- Alternative 1 is pure scalar code.
- Alternative 2 is a software sequence for scatter.
- Alternative 3 is a hardware scatter.

NOTE

A hardware Scatter operation issues as many store operations, as the number of elements in the vector. Do not use a scatter operation to store sequential elements, which can be stored with one vmov instruction.

Example 18-17. Scatter

Scalar	
<pre> mov rax, plmage //input mov rcx, pOutImage //output mov rbx, plIndex //indexes mov rdx, len //length xor r9, r9 mainloop: mov r9d, [rbx+rdx-0x4] vcvtss2ss xmm0, xmm0, qword ptr [rax+rdx*2-0x8] vmovss [rcx+r9*4], xmm0 sub rdx, 4 jnz mainloop </pre>	
Baseline 1x	
Software Sequence	Hardware Scatter

Example 18-17. Scatter

<pre> shufMaskP: .quad 0x0000000200000001 .quad 0x0000000400000003 .quad 0x0000000600000005 .quad 0x0000000800000007 mov rax, plmage //input mov rcx, pOutImage //output mov rbx, plIndex //indexes mov rdx, len //length mov r9, shufMaskP vmovaps ymm2, [r9] mainloop: vmovaps zmm1, [rax + rdx*2 - 0x80] //load data vcvtuqq2ps ymm0, zmm1 //convert to float movsxd r9, [rbx + rdx - 0x40] //load 8th index vmovss [rcx + 4*r9], xmm0 vpermd ymm0, ymm2, ymm0 movsxd r9, [rbx + rdx - 0x3c] //load 7th index vmovss [rcx + 4*r9], xmm0 vpermd ymm0, ymm2, ymm0 movsxd r9, [rbx + rdx - 0x38] //load 6th index vmovss [rcx + 4*r9], xmm0 vpermd ymm0, ymm2, ymm0 movsxd r9, [rbx + rdx - 0x34] //load 5th index vmovss [rcx + 4*r9], xmm0 vpermd ymm0, ymm2, ymm0 movsxd r9, [rbx + rdx - 0x30] //load 4th index vmovss [rcx + 4*r9], xmm0 vpermd ymm0, ymm2, ymm0 movsxd r9, [rbx + rdx - 0x2c] //load 3rd index vmovss [rcx + 4*r9], xmm0 vpermd ymm0, ymm2, ymm0 </pre>	<pre> mov rax, plmage //input mov rcx, pOutImage //output mov rbx, plIndex //indexes mov rdx, len //length mainloop: vmovdqa32 zmm0, [rbx+rdx-0x40] vmovdqa32 zmm1, [rax+rdx*2-0x80] vcvtuqq2ps ymm1, zmm1 vmovdqa32 zmm2, [rax+rdx*2-0x40] vcvtuqq2ps ymm2, zmm2 vshuff32x4 zmm1, zmm1, zmm2, 0x44 kxnorw k1,k1,k1 vscatterdps [rcx+4*zmm0] {k1}, zmm1 sub rdx, 0x40 jnz mainloop </pre>
--	---

Example 18-17. Scatter

<pre> movsxd r9, [rbx + rdx - 0x28] //load 2nd index vmovss [rcx + 4*r9], xmm0 vpermd ymm0, ymm2, ymm0 movsxd r9, [rbx + rdx - 0x24] //load 1st index vmovss [rcx + 4*r9], xmm0 vmovaps zmm1, [rax + rdx*2 - 0x40] //load data vcvtuqq2ps ymm0, zmm1 //convert to float movsxd r9, [rbx + rdx - 0x20] //load 8th index vmovss [rcx + 4*r9], xmm0 vpermd ymm0, ymm2, ymm0 movsxd r9, [rbx + rdx - 0x1c] //load 7th index vmovss [rcx + 4*r9], xmm0 vpermd ymm0, ymm2, ymm0 movsxd r9, [rbx + rdx - 0x18] //load 6th index vmovss [rcx + 4*r9], xmm0 vpermd ymm0, ymm2, ymm0 movsxd r9, [rbx + rdx - 0x14] //load 5th index vmovss [rcx + 4*r9], xmm0 vpermd ymm0, ymm2, ymm0 movsxd r9, [rbx + rdx - 0x10] //load 4th index vmovss [rcx + 4*r9], xmm0 vpermd ymm0, ymm2, ymm0 movsxd r9, [rbx + rdx - 0xc] //load 3rd index vmovss [rcx + 4*r9], xmm0 vpermd ymm0, ymm2, ymm0 movsxd r9, [rbx + rdx - 0x8] //load 2nd index vmovss [rcx + 4*r9], xmm0 vpermd ymm0, ymm2, ymm0 movsxd r9, [rbx + rdx - 0x4] //load 1st index vmovss [rcx + 4*r9], xmm0 sub rdx, 0x40 jnz mainloop </pre>	
Speedup: 1.48x	Speedup: 1.53x

18.12 STATIC ROUNDING MODES, SUPPRESS-ALL-EXCEPTIONS (SAE)

The Suppress-all-exceptions (SAE) feature was added to Intel AVX-512 floating-point instructions. This feature is helpful when spurious flag settings are undesirable. Although current implementations of vector math functions usually allow spurious flag settings, they can cause problems for applications that run with exceptions enabled. Standard-compliant code does not allow spurious flag settings.

In addition to standard-mandated uses (IEEE, OpenCL), static rounding modes have applications in math libraries that operate under the default rounding mode (which can be dynamically set).

18.13 QWORD INSTRUCTION SUPPORT

Intel AVX-512 extends QWORD support to many instructions introduced in Intel AVX and Intel AVX2. QWORD support was added to the instructions as detailed in the following sections.

18.13.1 QUADWORD Support in Arithmetic Instructions

Intel AVX-512 adds new quadword extension to *vpmaxsq*, *vpmaxuq*, *vpminsq*, *vpminuq*, and *vpnullq*.

The following example will store to array *c* the max value between the sum and the multiply of two 64bit numbers.

```
const int N = miBufferWidth;
const __int64* restrict a = A;
const __int64* restrict b = B;
__int64* restrict c = Cref;

for (int i = 0; i < N; i++){
    __int64 sum = a[i] + b[i];
    __int64 mul = a[i] * b[i];
    c[i] = mul > sum ? mul : sum;
}
```

The code below shows how the new support reduces instruction count from 118 in Intel AVX2 to 30 in Intel AVX-512 and results in a 3.1x speedup.

Example 18-18. QWORD Example, Intel® AVX2 vs. Intel® AVX-512

Intel® AVX2 Intrinsics	Intel® AVX-512 Intrinsics
<pre>for (int i = 0; i < N; i+= 32){ __m256i aa, bb, aah, bbh, mul, sum; #pragma unroll(8) for (int j = 0; j < 8; j++){ aa = _mm256_loadu_si256((const __m256i*)(a+i+4*j)); bb = _mm256_loadu_si256((const __m256i*)(b+i+4*j)); sum = _mm256_add_epi64(aa, bb); mul = _mm256_mul_epu32(aa, bb); aah = _mm256_srli_epi64(aa, 32); bbh = _mm256_srli_epi64(bb, 32); aah = _mm256_mul_epu32(aah, bb); bbh = _mm256_mul_epu32(bbh, aa); aah = _mm256_add_epi32(aah, bbh); aah = _mm256_slli_epi64(aah, 32); mul = _mm256_add_epi64(mul, aah); aah = _mm256_cmpgt_epi64(mul, sum); aa = _mm256_castpd_si256 (_mm256_blendv_pd(_mm256_castsi256_pd (sum), _mm256_castsi256_pd(mul), _mm256_castsi256_pd(aah))); _mm256_storeu_si256((__m256i*)(c+4*j), aa); } c += 32; }</pre>	<pre>for (int i = 0; i < N; i+= 32){ __m512i aa, bb, mul, sum; #pragma unroll(4) for (int j = 0; j < 4; j++){ aa = _mm512_loadu_si512((const __m512i*)(a+i+8*j)); bb = _mm512_loadu_si512((const __m512i*)(b+i+8*j)); sum = _mm512_add_epi64(aa, bb); mul = _mm512_mullo_epi64(aa, bb); aa = _mm512_max_epi64(sum, mul); _mm512_storeu_si512((__m512i*)(c+8*j), aa); } c += 32; }</pre>
Baseline 1x	Speedup: 3.1x

Example 18-18. QWORD Example, Intel® AVX2 vs. Intel® AVX-512 (Contd.)

Intel® AVX2 Assembly	Intel® AVX-512 Assembly
<pre> loop: vmovdq32 ymm28, ymmword ptr [rax+rcx*8+0x20] inc r9d vmovdq32 ymm26, ymmword ptr [r11+rcx*8+0x20] vmovdq32 ymm17, ymmword ptr [r11+rcx*8] vmovdq32 ymm19, ymmword ptr [rax+rcx*8] vmovdq ymm13, ymmword ptr [rax+rcx*8+0x40] vmovdq ymm11, ymmword ptr [r11+rcx*8+0x40] vpsrlq ymm25, ymm28, 0x20 vpsrlq ymm27, ymm26, 0x20 vpsrlq ymm16, ymm19, 0x20 vpsrlq ymm18, ymm17, 0x20 vpaddq ymm6, ymm28, ymm26 vpsrlq ymm10, ymm13, 0x20 vpsrlq ymm12, ymm11, 0x20 vpaddq ymm0, ymm19, ymm17 vpmuludq ymm29, ymm25, ymm26 vpmuludq ymm30, ymm27, ymm28 vpadd ymm31, ymm29, ymm30 vmovdq32 ymm29, ymmword ptr [r11+rcx*8+0x80] vpsllq ymm5, ymm31, 0x20 vmovdq32 ymm31, ymmword ptr [rax+rcx*8+0x80] vpsrlq ymm30, ymm29, 0x20 vpmuludq ymm20, ymm16, ymm17 vpmuludq ymm21, ymm18, ymm19 vpmuludq ymm4, ymm28, ymm26 vpadd ymm22, ymm20, ymm21 vpaddq ymm7, ymm4, ymm5 vpsrlq ymm28, ymm31, 0x20 vmovdq32 ymm20, ymmword ptr [r11+rcx*8+0x60] vpsllq ymm24, ymm22, 0x20 vmovdq32 ymm22, ymmword ptr [rax+rcx*8+0x60] vpsrlq ymm21, ymm20, 0x20 vpaddq ymm4, ymm22, ymm20 vpcmpgtq ymm8, ymm7, ymm6 vblendvpd ymm9, ymm6, ymm7, ymm8 vmovups ymmword ptr [rsi+0x20], ymm9 vpmuludq ymm14, ymm10, ymm11 vpmuludq ymm15, ymm12, ymm13 vpmuludq ymm8, ymm28, ymm29 vpmuludq ymm9, ymm30, ymm31 vpmuludq ymm23, ymm19, ymm17 vpadd ymm16, ymm14, ymm15 vpsrlq ymm19, ymm22, 0x20 vpadd ymm10, ymm8, ymm9 vpaddq ymm1, ymm23, ymm24 </pre>	<pre> loop: vmovups zmm0, zmmword ptr [rax+rcx*8] inc r9d vmovups zmm5, zmmword ptr [rax+rcx*8+0x40] vmovups zmm10, zmmword ptr [rax+rcx*8+0x80] vmovups zmm15, zmmword ptr [rax+rcx*8+0xc0] vmovups zmm1, zmmword ptr [r11+rcx*8] vmovups zmm6, zmmword ptr [r11+rcx*8+0x40] vmovups zmm11, zmmword ptr [r11+rcx*8+0x80] vmovups zmm16, zmmword ptr [r11+rcx*8+0xc0] vpaddq zmm2, zmm0, zmm1 vpmullq zmm3, zmm0, zmm1 vpaddq zmm7, zmm5, zmm6 vpmullq zmm8, zmm5, zmm6 vpaddq zmm12, zmm10, zmm11 vpmullq zmm13, zmm10, zmm11 vpaddq zmm17, zmm15, zmm16 vpmullq zmm18, zmm15, zmm16 vpmaxsq zmm4, zmm2, zmm3 vpmaxsq zmm9, zmm7, zmm8 vpmaxsq zmm14, zmm12, zmm13 vpmaxsq zmm19, zmm17, zmm18 vmovups zmmword ptr [rsi], zmm4 vmovups zmmword ptr [rsi+0x40], zmm9 vmovups zmmword ptr [rsi+0x80], zmm14 vmovups zmmword ptr [rsi+0xc0], zmm19 add rcx, 0x20 add rsi, 0x100 cmp r9d, r8d jb loop </pre>

Example 18-18. QWORD Example, Intel® AVX2 vs. Intel® AVX-512 (Contd.)

Intel® AVX2 Assembly	Intel® AVX-512 Assembly
<pre> vpsllq ymm18, ymm16, 0x20 vmovdq32 ymm28, ymmword ptr [rax+rcx*8+0xc0] vpsllq ymm12, ymm10, 0x20 vpmuludq ymm23, ymm19, ymm20 vpmuludq ymm24, ymm21, ymm22 vpadd ymm25, ymm23, ymm24 vmovdq32 ymm19, ymmword ptr [rax+rcx*8+0xa0] vpsllq ymm27, ymm25, 0x20 vpsrlq ymm25, ymm28, 0x20 vpsrlq ymm16, ymm19, 0x20 vpcmpgtq ymm2, ymm1, ymm0 vblendvpd ymm3, ymm0, ymm1, ymm2 vpaddq ymm0, ymm13, ymm11 vmovups ymmword ptr [rsi], ymm3 vpmuludq ymm17, ymm13, ymm11 vpmuludq ymm11, ymm31, ymm29 vpaddq ymm1, ymm17, ymm18 vpaddq ymm13, ymm31, ymm29 vpaddq ymm14, ymm11, ymm12 vmovdq32 ymm17, ymmword ptr [r11+rcx*8+0xa0] vmovdq ymm12, ymmword ptr [r11+rcx*8+0xe0] vpsrlq ymm18, ymm17, 0x20 vpcmpgtq ymm2, ymm1, ymm0 vpmuludq ymm26, ymm22, ymm20 vpcmpgtq ymm15, ymm14, ymm13 vblendvpd ymm3, ymm0, ymm1, ymm2 vblendvpd ymm0, ymm13, ymm14, ymm15 vmovdq ymm14, ymmword ptr [rax+rcx*8+0xe0] vmovups ymmword ptr [rsi+0x40], ymm3 vmovups ymmword ptr [rsi+0x80], ymm0 vpaddq ymm5, ymm26, ymm27 vpsrlq ymm11, ymm14, 0x20 vpsrlq ymm13, ymm12, 0x20 vpaddq ymm1, ymm19, ymm17 vpaddq ymm0, ymm14, ymm12 vmovdq32 ymm26, ymmword ptr [r11+rcx*8+0xc0] vpmuludq ymm20, ymm16, ymm17 add rcx, 0x20 vpmuludq ymm21, ymm18, ymm19 vpadd ymm22, ymm20, ymm21 vpsrlq ymm27, ymm26, 0x20 vpsllq ymm24, ymm22, 0x20 vpmuludq ymm29, ymm25, ymm26 vpmuludq ymm30, ymm27, ymm28 vpmuludq ymm15, ymm11, ymm12 vpmuludq ymm16, ymm13, ymm14 vpmuludq ymm23, ymm19, ymm17 vpadd ymm31, ymm29, ymm30 vpadd ymm17, ymm15, ymm16 </pre>	

Example 18-18. QWORD Example, Intel® AVX2 vs. Intel® AVX-512 (Contd.)

<pre> vpaddq ymm2, ymm23, ymm24 vpsllq ymm19, ymm17, 0x20 vpcmpgtq ymm6, ymm5, ymm4 vblendvpd ymm7, ymm4, ymm5, ymm6 vpsllq ymm6, ymm31, 0x20 vmovups ymmword ptr [rsi+0x60], ymm7 vpaddq ymm7, ymm28, ymm26 vpcmpgtq ymm3, ymm2, ymm1 vpmuludq ymm5, ymm28, ymm26 vpmuludq ymm18, ymm14, ymm12 vblendvpd ymm4, ymm1, ymm2, ymm3 vpaddq ymm8, ymm5, ymm6 vpaddq ymm1, ymm18, ymm19 vmovups ymmword ptr [rsi+0xa0], ymm4 vpcmpgtq ymm9, ymm8, ymm7 vpcmpgtq ymm2, ymm1, ymm0 vblendvpd ymm10, ymm7, ymm8, ymm9 vblendvpd ymm3, ymm0, ymm1, ymm2 vmovups ymmword ptr [rsi+0xc0], ymm10 vmovups ymmword ptr [rsi+0xe0], ymm3 add rsi, 0x100 cmp r9d, r8d jb loop </pre>	
Baseline 1x	Speedup: 3.1x

18.13.2 QUADWORD Support in Convert Instructions

The following tables demonstrate the new quadword extension in convert instructions.

Table 18-3. Vector Quadword Extensions

From / To	Vector SP	Vector DP	Vector int64	Vector uint64
Vector SP	-		vcvtps2qq	vcvtps2uqq
Vector DP		-	vcvtpd2qq	vcvtpd2qq
Vector int64	vcvtqq2ps	vcvtqq2pd	-	
Vector uint64	vcvtqq2ps	vcvtuqq2pd		-

Table 18-4. Scalar Quadword Extensions

From / To	Scalar SP	Scalar DP	Scalar int64	Scalar uint64
Scalar SP	-		vcvtss2si	vcvtss2usi
Scalar DP		-	vcvtss2si	vcvtss2usi
Scalar int64	vcvtusi2sd	vcvtusi2sd	-	
Scalar uint64	vcvtusi2sd	vcvtusi2sd		-

18.13.3 QUADWORD Support for Convert with Truncation Instructions

The following tables demonstrate the new quadword extension in convert with truncate instructions.

Table 18-5. Vector Quadword Extensions

From / To	Vector int64	Vector uint64
Vector SP	vcvttps2qq	vcvttps2uqq
Vector DP	vcvttpd2qq	vcvttpd2qq

Table 18-6. Scalar Quadword Extensions

From / To	Scalar int64	Scalar uint64
Scalar SP	vcvttss2si	vcvttss2usi
Scalar DP	vcvttsd2si	vcvttsd2usi

18.14 VECTOR LENGTH ORTHOGONALITY

All Intel AVX-512 instructions, in processors that support Vector Length Extensions (VL), can operate at three vector lengths: 128-bit, 256-bit and 512-bit. All of these vector lengths are supported by all Intel AVX-512 instructions, except instructions with Embedded Rounding.

In the instruction encoding, the same two bits are used for encoding vector length and embedded rounding control, therefore when embedded rounding is used, the vector length is automatically assumed to be 512 bits (maximum vector length in Intel AVX-512).

See also Section 18.10, "Embedded Rounding".

18.15 INTEL® AVX-512 INSTRUCTIONS FOR TRANSCENDENTAL SUPPORT

This section lists and describes the new instructions introduced by Intel AVX-512 for transcendental support.

18.15.1 VRCP14, VRSQRT14 - Software Sequences for $1/x$, x/y , \sqrt{x}

Syntax:

VRCP14PD/PS dest, src

VRSQRT14PD/PS dest, src

18.15.1.1 Application Examples

There are software sequences for Reciprocal, Division, Square Root, and Inverse Square Root instructions.

Software sequences for $1/x$, x/y , \sqrt{x} are beneficial for throughput (not so much for latency, unless the accuracy is quite low). They are typically implemented via Newton-Raphson approximations, or polynomial approximations.

One advantage of VRCP14 and VRSQRT14 is the improved accuracy, compared with the legacy RCPPS, RSQRTPS. This helps shorten the computation, in particular for double precision (which requires two instead of three Newton-Raphson iterations for a 50-52 bit approximation).

Another advantage of these instructions is that they have double-precision versions (while the legacy RCP/RSQRT instructions did not). This further boosts double-precision performance. On Skylake Server

microarchitecture, double precision reciprocal and square root software sequences have significantly better throughput than the VDIV and VSQRT instructions in 512-bit vector mode Double Precision Transcendental Argument Reductions (e.g., log, cbrt).

In functions such as log() or the cube root (cbrt), a rounded VRCP14PD result can be used in place of an expensive reciprocal table lookup. The same technique could be used before via RCPPS, but was less efficient for double-precision.

See Section 18.15.3, “VRNDSCALE - Vector Round Scale” for a log() argument reduction example.

18.15.2 VGETMANT VGETEXP - Vector Get Mantissa and Vector Get Exponent

Syntax:

VGETMANTPD/PS dest_mant, src, imm

VGETEXPPD/PS dest_exp, src

18.15.2.1 Application Examples

Logarithm Function

$$\log_2(x) = \text{VGETEXP}(x) + \log_2(\text{VGETMANT}(x, 8))$$

$$\log(x) = \text{VGETEXP}(x) * \log(2.0) + \log(\text{VGETMANT}(x, 8))$$

As seen above, the computation is reduced to computing $\log(\text{VGETMANT}(x, 8))$, where $\text{VGETMANT}(x, 8)$ is guaranteed to be in $[1, 2)$ for all valid function inputs, and NaN for invalid inputs ($x < 0$).

A variety of algorithms can be applied to compute the logarithm of the mantissa. The selection of a particular algorithm may depend on the desired accuracy, on optimization goals (latency or throughput optimized), or on specifics of the microarchitecture. Some algorithms may use other normalization options for the mantissa: $[0.5, 1)$ or $[0.75, 1.5)$; however, the basic identity underlying the computation is shown above.

See Section 18.15.5, “VSCALEF - Vector Scale” for details on X^{alpha} (constant alpha) and division.

18.15.3 VRNDSCALE - Vector Round Scale

Syntax:

VRNDSCALEPD/PS dest, src, imm

18.15.3.1 Application Examples

Lookup tables are frequently used in transcendental function implementations. The table index is most often based on a few leading bits of the input. VRNDSCALE can be used as part of the argument reduction process, to form the floating-point input value corresponding to the table index. The following example implements the argument reduction for $\log(x)$, where $1 \leq x < 2$:

```
y = RCP14(x);           // y is in (0.5, 1]
y0=VRNDSCALE(y, k*16); // y0 has k mantissa bits (leading 1
                        // included)
R = x*y0 - 1;          // |R| < 2^-14+2-k.
```

Therefore $\log(x) = -\log(y_0) + \log(1+R)$.

$\log(1+R)$ can be computed via a polynomial, and $\log(y_0)$ can be retrieved from a lookup table of $2k-1+1$ elements, or $2k-1$ elements, at the expense of an additional check.

18.15.4 VREDUCE - Vector Reduce

Syntax:

VREDUCEPD/PS dest, src, imm

18.15.4.1 Application Examples

The most significant benefit of VREDUCE is latency reduction in common transcendental operations such as exp2 and pow (which includes an exp2 operation). Uses in other transcendental functions such as atan() are also possible.

See Section 18.15.5, "VSCALEF - Vector Scale".

18.15.5 VSCALEF - Vector Scale

Syntax:

VSCALEFPD/PS dest, src1, src2

18.15.5.1 Application Examples

exp2 (2x)

exp2(x) = VSCALEF(2VREDUCE(x, RD_mode), x)

$R(x) = VREDUCE(x, RD_mode) = x - \text{floor}(x)$ is in $[0, 1)$. $2R(x)$ is computed by other means, such as polynomial approximation, or table lookup with polynomial approximation. VSCALEF correctly handles overflow and underflow. It is also defined to handle exp() special cases correctly (such as when the input is an Infinity), so there is no need for special paths in a vector implementation. In the absence of VSCALEF, inputs that are very large in magnitude require a separate path.

Since explicit exponent manipulation is no longer needed, VSCALEF also helps improve throughput.

Exp(x)

Exp(x) = VSCALEF(2R(x), x*(1/log(2.0)),

where,

$R(x) = x - \log(2.0)*\text{floor}(x*(1/\log(2.0)))$;

$R(x)$ is accurately computed by using a sufficiently long log(2.0) approximation (longer than the native floating-point format).

As with exp2(), the advantages of using VSCALEF are better throughput and elimination of secondary branches.

x^{alpha} (constant alpha)

For example, alpha=1/3 (the cube root function, cbrt).

The basic reduction for this computation is:

$x^{\text{alpha}} = VSCALEF((VGETMANT(x, imm))^{\text{alpha}}?2VREDUCE(VGETEXP(x)*\text{alpha}, RD_mode), VGETEXP(x)*\text{alpha})$

selecting the immediate (imm) is based on the value of the alpha constant.

Division:

$a/b = VSCALEF(VGETMANT(a, 0)/VGETMANT(b, 0), VGETEXP(a) - VGETEXP(b))$

This reduction allows for a branch-free implementation of divide, that covers overflow, underflow, and special inputs (zeroes, Infinities, or denormals).

$|VGETMANT(x,0)|$ is in $[1,2)$ for all non-NaN inputs.

$VGETMANT(a,0)/VGETMANT(b,0)$ can be computed to the desired accuracy.

The suppress-all-exceptions (SAE) feature available in Intel AVX-512 can help ensure spurious flag settings do not occur. Flags can be set correctly as part of the computation (except for divide-by-zero, which requires an additional step).

For high accuracy or IEEE compliance, the hardware instruction typically provides better performance, especially in terms of latency.

18.15.6 VFPCLASS - Vector Floating Point Class

Syntax:

VFPCLASSPD/PS dest_mask, src, imm

18.15.6.1 Application Examples

The VFPCLASS instruction is used to detect special cases so they can be directed to a special path, or alternatively, handled with masked operations in the main path. See two examples below.

Reciprocal Sequence, Square Root Sequence:

The reduced argument for the $1/x$ computation is $e=1-x*\text{RCP14}(x)$. This expression evaluates to NaN when x is ± 0 or $\pm \text{Inf}$, as RCP14 returns the correct result for these special cases. VFPCLASS enables you to set $\text{mask}=1$ for $x=\pm 0$ or $\pm \text{Inf}$, and $\text{mask}=0$ for all other x . This mask can then be used to select between the RCP14 output (result for special cases), or the result of a reciprocal refinement computation starting with RCP14 (for typical inputs).

In a similar manner, a square root computation based on RSQRT14 can use the VFPCLASS instruction to create a mask for $=\pm 0$ or $x=+\text{Inf}$.

Pow(x,y) function:

The main path of $\text{pow}(x,y)=2^{y*\log_2(x)}$ does not operate on $x\neq 0$, $x=\text{Inf}/\text{NaN}$, or $y=\text{Inf}/\text{NaN}$. One VFPCLASS op can be used to set $\text{special_x_mask}=1$ for $x\neq 0$ or $x=\text{Inf}/\text{NaN}$. A second VFPCLASS op would be used to set $\text{special_y_mask}=1$ for $y=\text{Inf}/\text{NaN}$. A branch to a secondary path is taken if either mask is set.

18.15.7 VPERM, VPERMI2, VPERMT2 - Small Table Lookup Implementation

18.15.7.1 Application Examples

Math library functions are frequently implemented using table lookups. In vector mode, large table lookups would use vector gather. Small table lookups can be implemented via the VPERM* instructions, which are significantly faster.

Examples of common transcendental functions that achieved very significant speedup using VPERM* for table lookups: $\exp()$, $\log()$, $\text{pow}()$ - both single and double precision.

18.16 CONFLICT DETECTION

The Intel AVX-512 Conflict Detection instructions are instructions that, together with Intel AVX-512 Foundation instructions, enable efficient vectorization of loops with possible vector dependencies (i.e., conflicts) through memory. VPCONFLICT performs horizontal comparisons of elements within a single vector register. VPCONFLICT compares each element of a vector register with all previous elements in that register, and outputs the results of all of the comparisons. These horizontal comparisons can be used for other purposes.

Other conflict detection instructions allow for efficient manipulation of the comparison results. The VPLZCNT instruction lets us generate controls for in-register permute operations used to combine vector elements with matching values.

18.16.1 Vectorization with Conflict Detection

The Intel AVX-512CD instructions allow efficient vectorization of loops with reads and writes through an array of pointers (e.g., `*ptr[i] += val[i]`) or an indirectly addressed array (e.g., `A[B[i]] += val[i]`).

Consider the following histogram computation:

```
for(int i = 0; i < num_inputs; i++)
{
    histogram[input[i] & (num_bins - 1)]++;
}
```

If `input[0] = input[1] = 3`, we will get an incorrect answer if we use SIMD instructions to read `histogram[input[0]]` and `histogram[input[1]]` into a register (with a gather), increment them, and then write them back (with a scatter). After this sequence, the value in `histogram[3]` will be 1, when it should be 2.

The problem occurs because we have duplicate indices; this creates a dependence between the write to the histogram in iteration 0 and the read from the histogram in iteration 1 - the read should get the value of the previous write.

To detect this scenario, look for duplicate indices (or pointer values), using the `VPCONFLICT` instruction. This instruction compares each element of a vector register with all previous elements in that register.

Example:

```
vpconflictd zmm0, zmm1
```

The figure below is an example that shows the execution of a `VPCONFLICTD` instruction. The input, `ZMM1`, contains 16 integers, shown in the light grey boxes. `ZMM1` is at the top of the figure, and also visually transposed along the left-hand side of the figure. The white boxes show the equality comparisons that the hardware performs between different elements of `ZMM1`, and the outcome of each comparison (0 = not equal, 1 = equal). Each comparison output is a single bit in the output of the instruction. Comparisons that are not performed (i.e., the dark grey boxes) produce a single '0' bit in the output. Finally, the output register, `ZMM0`, is shown at the bottom of the figure. Each element is shown as a decimal representation of the bits above it.

Use `VPCONFLICT` in different ways to help vectorize loops.

The simplest option is to check for any duplicate indices in a given SIMD register. If there are none, SIMD instructions can be used to compute all elements simultaneously. If conflicts are present, execute a scalar loop for that group of elements.

Branching to a scalar version of the loop on any duplicate indices can work well if duplicates are extremely rare. However, if the chance of getting even one duplicate in a given iteration of the vectorized loop is large enough, then it is better to use SIMD as much as possible, to exploit as much parallelism as possible.

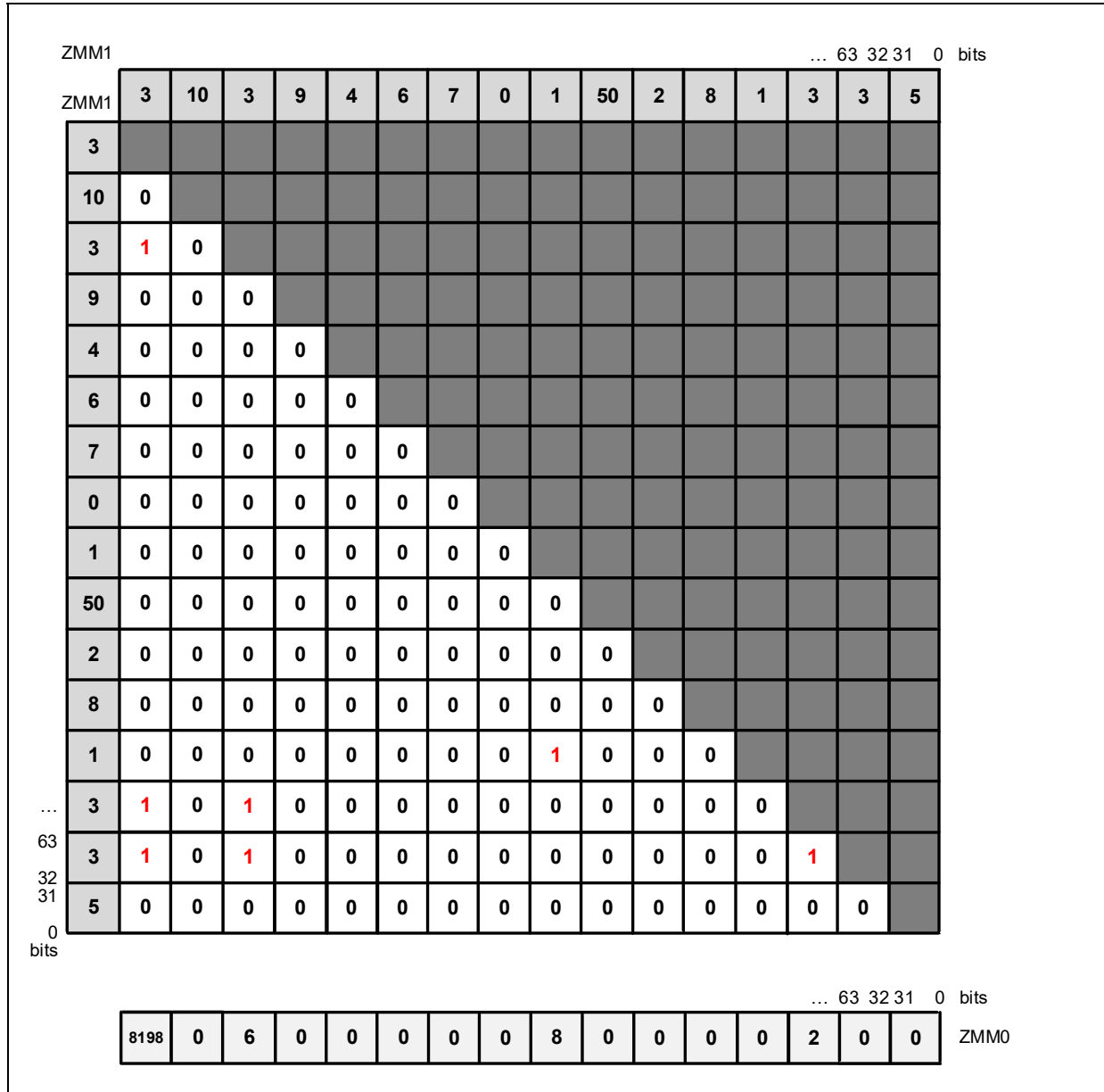

Figure 18-10. VPCONFLICTD Instruction Execution

For loops performing updates to memory locations, such as in the histogram example, minimize store-load forwarding by merging the updates to each distinct index while the data is in registers, and only perform a single write to each memory location. Further, the merge can be performed in a parallel fashion.

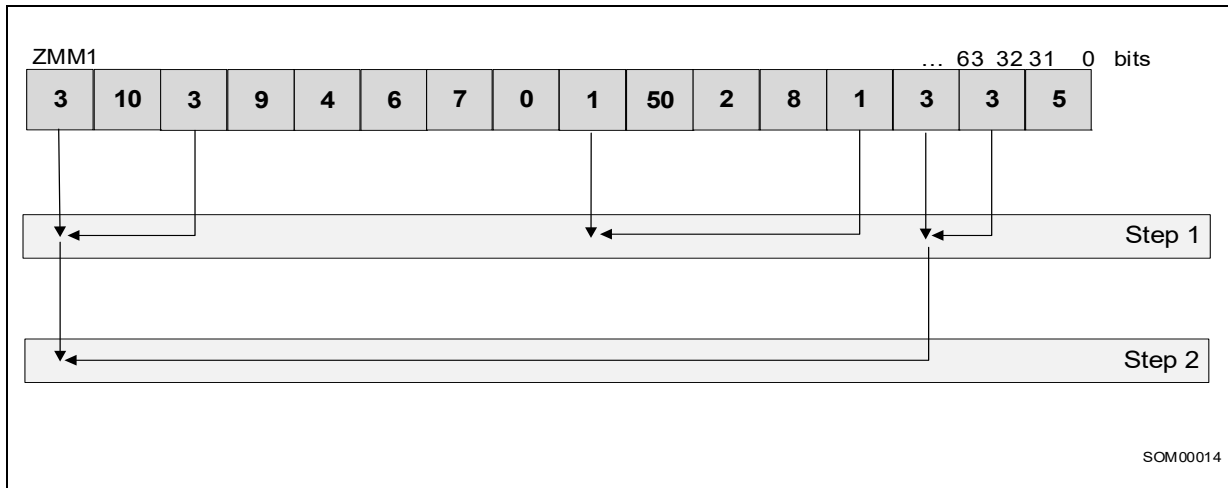

Figure 18-11. VPCONFLICTD Merging Process

The figure above shows the merging process for the example set of indices. While the figure shows only the indices, it actually merges the values. Most of the indices are unique, and thus require no merging. Step 1 combines three pairs of indices: two pairs of '3's and one pair of '1's. Step 2 combines the intermediate results for the '3's from step 1, so that there is now a single value for each distinct index. Notice that in only two steps, the four elements with an index value of 3 are merged, because we performed a tree reduction; we merged pairs of results or intermediate results at each step.

The merging (combining or reduction) process shown above is done with a set of permute operations. The initial permute control is generated with a VPLZCNT+VPSUB sequence. VPLZCNT provides the number of leading zeros for each vector element (i.e., contiguous zeros in the most significant bit positions). Subtracting the results of VPLZCNT from the number of bits in each vector element, minus one, provides the bit position of the most significant '1' bit in the result of the VPCONFLICT instruction, or results in a '-1' for an element if it has no conflicts. In the example above this sequence results in the following permute control.

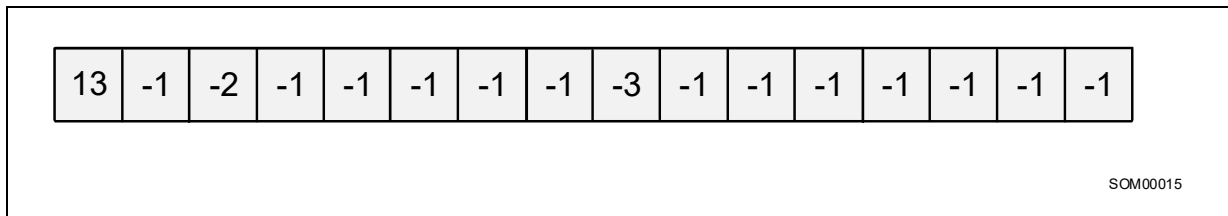

Figure 18-12. VPCONFLICTD Permute Control

The permute loop for merging matching indices and generating the next set of permute indices repeats until all values in the permute control become equal to '-1'.

The assembly code below shows both the scalar version of a histogram loop, and the vectorized version with a tree reduction. Speedups are modest because the loop contains little computation; the SIMD benefit comes almost entirely from vectorizing just the logical AND operation and the increment. SIMD speedups can be much higher for loops containing more vectorizable computation.

Example 18-19. Scatter Implementation Alternatives

Scalar Code (Unrolled Two Times)	Intel® AVX-512 Code
<pre> mov r9d, bins_minus_1 mov ebx, num_inputs mov r10, plnput mov r15, pHistogram xor rax, rax histogram_loop: lea ecx, [rax + rax] inc eax movsxd rcx, ecx mov esi, [r10+rcx*4] and esi, r9d mov r8d, [r10+rcx*4+4] movsxd rsi, esi and r8d, r9d movsxd r8, r8d inc dword ptr [r15+rsi*4] inc dword ptr [r15+r8*4] cmp eax, ebx jb histogram_loop </pre>	<pre> vmovaps zmm4, all_1 // {1, 1, ..., 1} vmovaps zmm5, all_negative_1 vmovaps zmm6, all_31 vmovaps zmm7, all_bins_minus_1 mov ebx, num_inputs mov r10, plnput mov r15, pHistogram xor rcx, rcx histogram_loop: vpandd zmm3, zmm7, [r10+rcx*4] vpconflictd zmm0, zmm3 kxnorw k1, k1, k1 vmovaps zmm2, zmm4 vpxord zmm1, zmm1, zmm1 vpgatherdd zmm1{k1}, [r15+zmm3*4] vptestmd k1, zmm0, zmm0 kortestw k1, k1 je update vplzcntd zmm0, zmm0 vpsubd zmm0, zmm6, zmm0 conflict_loop: vpermd zmm8{k1}{z}, zmm0, zmm2 vpermd zmm0{k1}, zmm0, zmm0 vpadd zmm2{k1}, zmm2, zmm8 vpcmpned k1, zmm5, zmm0 kortestw k1, k1 jne conflict_loop update: vpadd zmm0, zmm2, zmm1 kxnorw k1, k1, k1 add rcx, 16 vpscatterdd [r15+zmm3*4]{k1}, zmm0 cmp ecx, ebx jb histogram_loop </pre>
Scalar, Baseline, 1x	Speedup: 1.11x (random inputs); 1.34x (input values identical)

Notice that the end result of the conflict loop (i.e., the resulting vector after all merging is done, ZMM2 in the above sequence) holds the complete set of partial sums. That is, for each element, the result contains the value of that element merged with all earlier elements with the same index value. Using the earlier example values, ZMM2 contains the result shown in Figure 18-13.

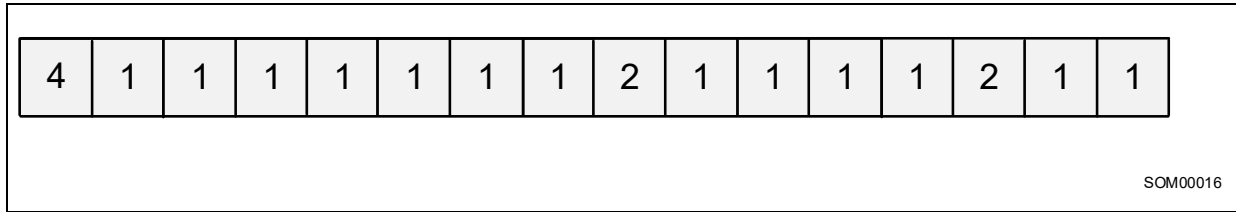

Figure 18-13. VPCONFLICTD ZMM2 Result

While the above sequence does not take advantage of this, other use cases might.

18.16.2 Sparse Dot Product with VPCONFLICT

A sparse vector may be stored as a pair of arrays: one containing non-zero values, and one containing the original locations of those values in the vector. Note that the indices are sorted in increasing order.

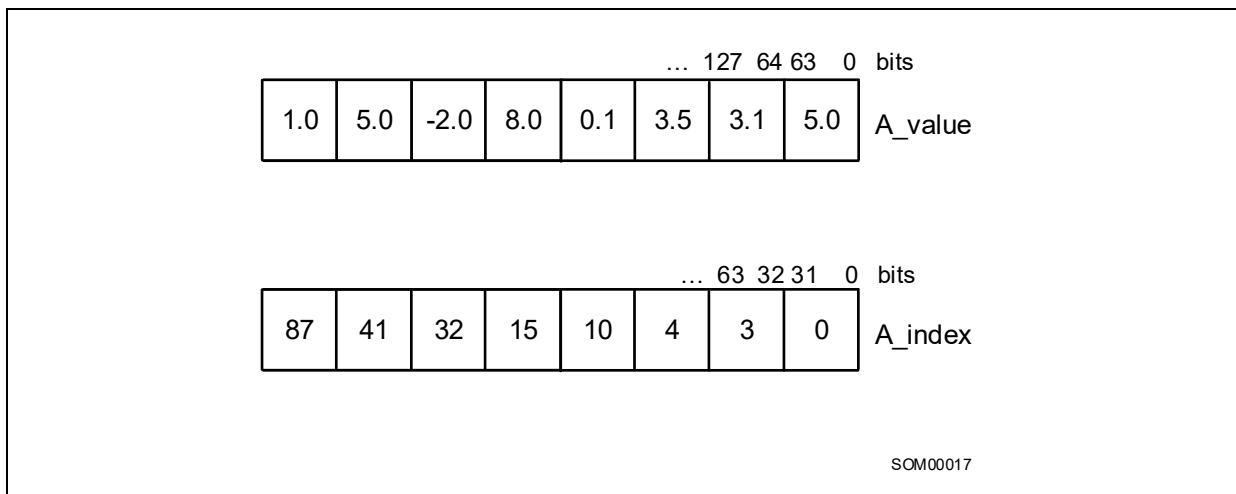

Figure 18-14. Sparse Vector Example

To perform a dot product of two sparse vectors efficiently, we need to find elements with matching indices; those are the only ones on which we should perform the multiply and accumulation. The scalar method for doing this is to start at the beginning of the two index arrays, compare those indices, and if there is a match, do the multiply and accumulate, then advance the indices of both vectors. If there is no match, we advance the index of the lagging vector.

```
A_offset = 0; B_offset = 0; sum = 0;
while ((A_offset < A_length) && (B_offset < B_length))
{
    if (A_index[A_offset] == B_index[B_offset]) // match
    {
        sum += A_value[A_offset] * B_value[B_offset];
        A_offset++;
        B_offset++;
    }
    else if (A_index[A_offset] < B_index[B_offset])
    {
        A_offset++;
    }
    else
    {
        B_offset++;
    }
}
```

The Intel AVX-512CD instructions provide an efficient way to vectorize this loop. Instead of comparing one index from each vector at a time, we can compare eight of them. First we combine eight indices from each vector into a single vector register. Then, the VPCONFLICT instruction compares the indices. We use the output to create a mask of elements in vector A that have a match, and also to create permute controls to move the corresponding values of B to the same location, so that we can use a vector FMA instruction.

Example 18-20 shows the assembly code for both the scalar and vector versions of a single comparison and FMA. For brevity, the offset updates and looping are omitted.

Example 18-20. Scalar vs. Vector Update Using AVX-512CD

Scalar Code	Intel® AVX-512 Code
<pre> mov rdx, A_index mov rcx, A_offset mov rax, A_value mov r12, B_index mov r13, B_offset mov rbx, B_value mov r10d, [rdx+rcx*4] mov r11d, [r12+r13*4] cmp r10d, r11d jne skip_fma // do the fma on a match movsd xmm5, [rbx+r13*8] mulsd xmm5, [rax+rcx*8] addsd xmm4, xmm5 skip_fma: </pre>	<pre> mov rdx, A_index mov rcx, A_offset mov rax, A_value mov r12, B_index mov r13, B_offset mov rbx, B_value mov r14, all_31s // array of {31, 31, ...} vmovaps zmm2, [r14] mov r15, upconvert_control // array of {0, 7, 0, 6, 0, 5, 0, 4, 0, 3, 0, 2, 0, 1, 0, 0} vmovaps zmm1, [r15] vpternlzd zmm0, zmm0, zmm0, 255 movl esi, 21845 kmovw k1, esi // odd bits set // read 8 indices for A vmovdqu ymm5, [rdx+rcx*4] // read 8 indices for B, and put // them in the high part of zmm6 vinserti64x4 zmm6, zmm5, [r12+r13*4], 1 vpsrlq zmm7, zmm6, 48 // extract A vs. B comparisons vextracti64x4 ymm8, zmm7, 1 // convert comparison results to // permute control vplzcntd zmm9, zmm8 vptestmd k2, zmm8, zmm0 vpsubd zmm10, zmm2, zmm9 // upconvert permute controls from // 32b to 64b, since data is 64b vpermd zmm11{k1}, zmm1, zmm10 // Move A values to corresponding // B values, and do FMA vpermpd zmm12{k2}{z}, zmm11, [rax+rcx*8] vfmadd231pd zmm4, zmm12, [rbx+r13*8] </pre>
Baseline, 1x	Speedup, 4.4x

18.17 INTEL® AVX-512 VECTOR BYTE MANIPULATION INSTRUCTIONS (VBMI)

Intel® AVX-512 VBMI instructions are a set of 512-bit instructions that are designed to speed up bit manipulation operations. The following sections describe the new instructions and show simple usage examples. See the *Intel® 64 and IA-32 Architectures Software Developer's Manual* for complete instruction definitions. Processors that provide VBMI1 and VBMI2 are enumerated by the CPUID feature flags CPUID:(EAX=07H, ECX=0):ECX[bit 01] = 1 and CPUID:(EAX=07H, ECX=0):ECX[bit 06] = 1, respectively.

18.17.1 Permute Packet Bytes Elements Across Lanes (VPERMB)

The VPERMB instruction is a single source, any-to-any byte permute instruction. The following figure shows a VPERMB instruction operation example.

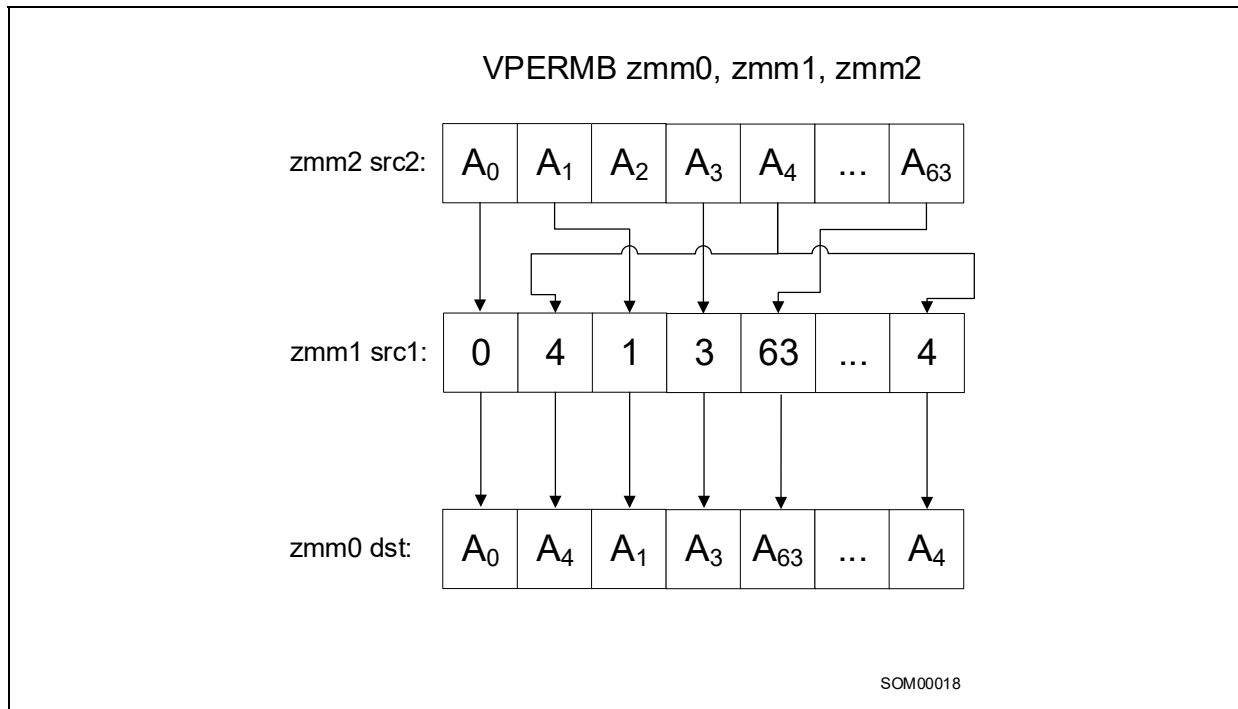

Figure 18-15. VPERMB Instruction Operation

VPERMB Operation:

```
// vpermb zmm Dst {k1}, zmm Src1, zmm Src2
bool zero_masking=false;
unsigned char *Dst, *Src1, *Src2;

for(int i=0;i<64;i++){
    if(k1[i]){
        Dst[i]= Src2[Src1[i]];
    }else{
        Dst[i]= zero_masking? 0 : Dst[i];
    }
}
```

The following example shows a 64-byte lookup table implementation.

Scalar code:

```
void lookup(unsigned char* in_bytes, unsigned char* out_bytes, unsigned char* dictionary_bytes, int numElements){
    for(int i = 0; i < numElements; i++) {
        out_bytes[i] = dictionary_bytes[in_bytes[i] & 63];
    }
}
```

Example 18-21. Improvement with VPERMB Implementation

Alternative 1: Vector Implementation Without VBMI	Alternative 2: VPERMB Implementation
<pre> mov rsi, dictionary_bytes mov r11, in_bytes mov rax, out_bytes mov r9d, numOfElements xor r8, r8 vpmovzxbw zmm3, [rsi] vpmovzxbw zmm4, [rsi+32] loop: vpmovzxbw zmm1, [r11+r8*1] vpmovzxbw zmm2, [r11+r8*1+32] vpermi2w zmm1, zmm3, zmm4 vpermi2w zmm2, zmm3, zmm4 vpmovwb [rax+r8*1], zmm1 vpmovwb [rax+r8*1+32], zmm2 add r8, 64 cmp r8, r9 jl loop </pre>	<pre> mov rsi, dictionary_bytes mov r11, in_bytes mov rax, out_bytes mov r9d, numOfElements xor r8, r8 vmovdqu32 zmm2, [rsi] loop: vmovdqu32 zmm1, [r11+r8*1] vpermb zmm1, zmm1, zmm2 vmovdqu32 [rax+r8*1], zmm1 add r8, 64 cmp r8, r9 jl loop </pre>
Base Measurement: 1x	Speedup: 6.5x

18.17.2 Two-Source Byte Permute Across Lanes (VPERMI2B, VPERMT2B)

The VPERMI2B and VPERMT2B instructions are two-source byte, permute instructions. The destination is also an operation source; in VPERMI2B the destination is the operation index, and in VPERMT2B the destination is one of the data sources.

The following figure shows a VPERMI2B instruction operation example.

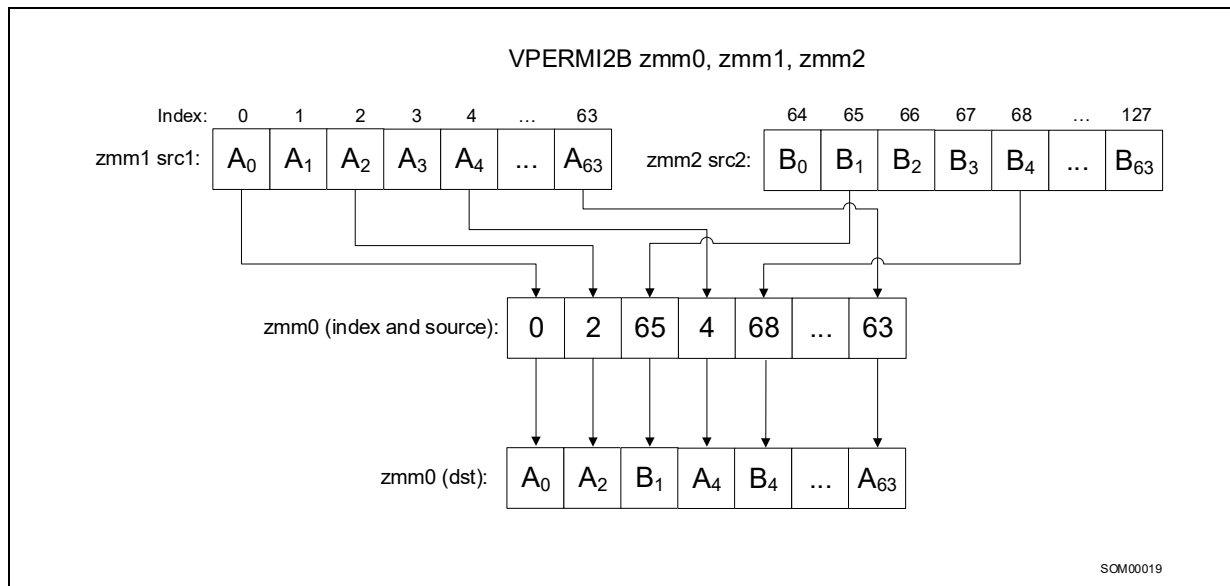

Figure 18-16. VPERMI2B Instruction Operation

VPERMI2B Operation:

```

/// vpermi2b Dst{k1}, Src1, Src2
bool zero_masking=false;
unsigned char *Dst, *Src1, *Src2;
for(int i=0;i<64;i++){
    if(k1[i]){
        Dst[i]= Dst [i]>63 ? Src1[Dst [i] & 63] : Src2[Dst [i] & 63] ;
    }else{
        Dst[i]= zero_masking? 0 : Dst[i];
    }
}

```

The following figure shows a VPERMT2B instruction operation example.

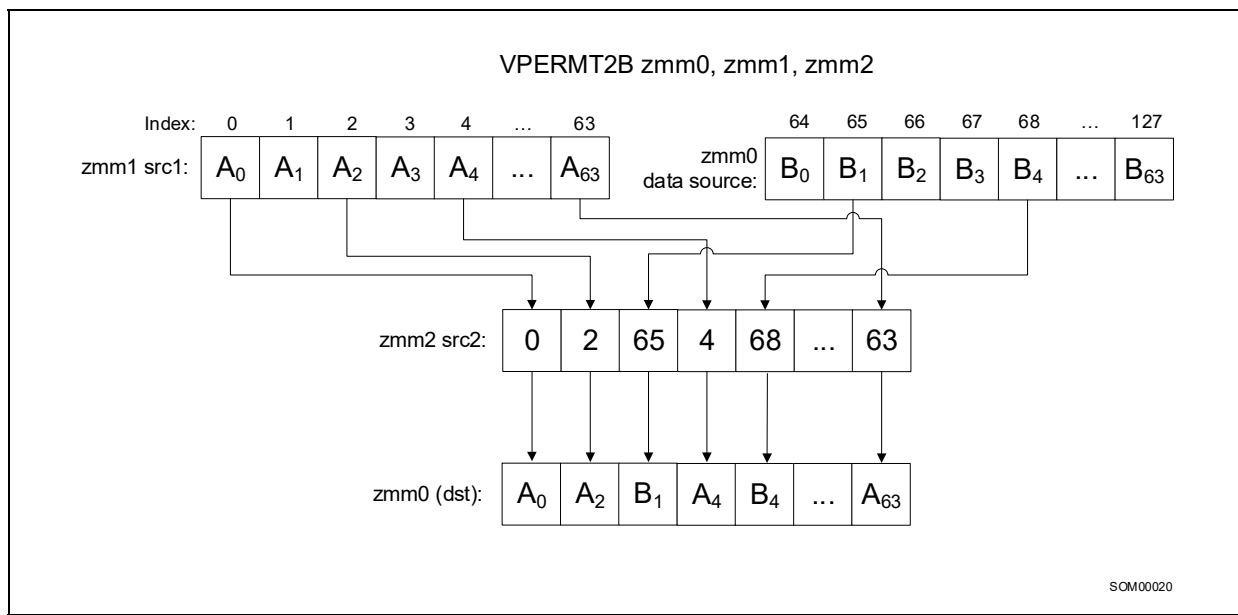

Figure 18-17. VPERMT2B Instruction Operation

VPERMT2B Operation:

```

// vpermt2b Dst{k1}, Src1, Src2
bool zero_masking=false;
unsigned char *Dst, *Src1, * Src2;
data2= copy(Dst);
for(int i=0;i<64;i++){
    if(k1[i]){
        Dst[i]= Src2[i]>63 ? Src1[Src2 [i] & 63] : Dst[Src2[i] & 63] ;
    }else{
        Dst[i]= zero_masking? 0 : Dst[i];
    }
}

```

The following example shows a 128-byte lookup table implementation.

C Code:

```
void lookup(unsigned char* in_bytes, unsigned char* out_bytes, unsigned char* dictionary_bytes, int numOfElements){
    for(int i = 0; i < numOfElements; i++) {
        out_bytes[i] = dictionary_bytes[in_bytes[i] & 127];
    }
}
```

Example 18-22. Improvement with VPERMI2B Implementation

Alternative 1: Vector Implementation Without VBMI	Alternative 2: VPERMI2B Implementation
<pre>//get data sent to function mov rsi, dictionary_bytes mov r11, in_bytes mov rax, out_bytes mov r9d, numOfElements xor r8, r8 //Reorganize dictionary vpmovzxbw zmm10, [rsi] vpmovzxbw zmm15, [rsi+64] vpsllw zmm15, zmm15, 8 vpord zmm10, zmm15, zmm10 vpmovzxbw zmm11, [rsi+32] vpmovzxbw zmm15, [rsi+96] vpsllw zmm15, zmm15, 8 vpord zmm11, zmm15, zmm11 //initialize constants mov r10, 0x00400040 vpbroadcastw zmm12, r10d mov r10, 0 vpbroadcastd zmm13, r10d mov r10, 0x00ff00ff vpbroadcastd zmm14, r10d //start iterations loop: vpmovzxbw zmm1, [r11+r8*1] vpandd zmm2, zmm1, zmm12 vpcmpw k1, zmm2, zmm13, 4 vpermi2w zmm1, zmm10, zmm11 vpsrlw zmm1{k1}, zmm1, 8 vpandd zmm1, zmm1, zmm14 vpmovwb [rax+r8*1], zmm1 add r8, 32 cmp r8, r9 jl loop</pre>	<pre>mov rsi, dictionary_bytes mov r11, in_bytes mov rax, out_bytes mov r9d, numOfElements xor r8, r8 vmovdqu32 zmm2, [rsi] vmovdqu32 zmm3, [rsi+64] loop: vmovdqu32 zmm1, [r11+r8*1] vpermi2b zmm1, zmm2, zmm3 vmovdqu32 [rax+r8*1], zmm1 add r8, 64 cmp r8, r9 jl loop</pre>
Base Measurement: 1x	Speedup: 5.3x

18.17.3 Select Packed Unaligned Bytes from Quadword Sources (VPMULTISHIFTQB)

The VPMULTISHIFTQB instruction selects eight unaligned bytes from each input qword element of the second source operand and writes eight assembled bytes for each qword element in the destination operand.

The following figure shows a VPMULTISHIFTQB instruction operation example.

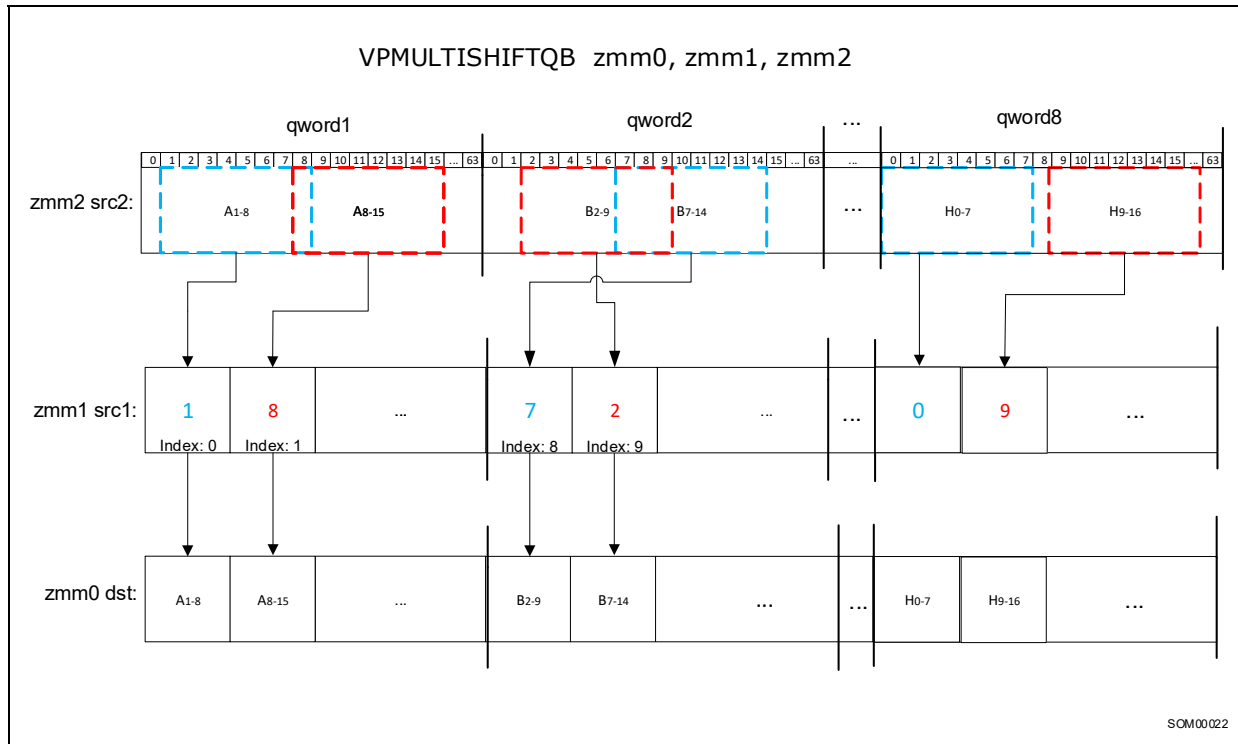

Figure 18-18. VPMULTISHIFTQB Instruction Operation

VPMULTISHIFTQB Operation:

```
// vpmultishiftqb Dst{k1},Src1,Src2
bool zero_masking=false;
unsigned char *Dst, * Src1;
unsigned __int64 *Src2;
bit * k1;
for(int i=0;i<8;j++){
    for(int j=0;j<8;j++){
        if(k1[i*8 +j]){
            Dst[i*8 +j]= (src2[i]>> Src1[i*8 +j]) &0xFF ;
        }else{
            Dst[i*8 +j]= zero_masking? 0 : Dst[i*8 +j];
        }
    }
}
}
```

The following example converts a 5-bit unsigned integer array to a 1-byte unsigned integer array.

C code:

```
void decompress (unsigned char* compressedData, unsigned char* decompressedData, int numOfElements){
    for(int i = 0; i < numOfElements; i += 8){
        unsigned __int64 * data = (unsigned __int64 *)compressedData;
        decompressedData[i+0] = *data & 0x1f;
        decompressedData[i+1] = (*data >> 5) & 0x1f;
        decompressedData[i+2] = (*data >> 10) & 0x1f;
        decompressedData[i+3] = (*data >> 15) & 0x1f;
        decompressedData[i+4] = (*data >> 20) & 0x1f;
        decompressedData[i+5] = (*data >> 25) & 0x1f;
        decompressedData[i+6] = (*data >> 30) & 0x1f;
        decompressedData[i+7] = (*data >> 35) & 0x1f;
        compressedData += 5;
    }
}
```

Example 18-23. Improvement with VPMULTISHIFTQB Implementation

Alternative 1: Vector Implementation Without VBMI	Alternative 2: VPMULTISHIFTQB Implementation
<pre>mov rdx, compressedData mov r9, decompressedData mov eax, numOfElements shr eax,3 xor rsi, rsi loop: mov rcx, qword ptr [rdx] mov r10, rcx and r10, 0x1f mov r11, rcx mov byte ptr [r9+rsi*8], r10b mov r10, rcx shr r10, 0xa add rdx, 0x5 and r10, 0x1f mov byte ptr [r9+rsi*8+0x2], r10b mov r10, rcx shr r10, 0xf and r10, 0x1f mov byte ptr [r9+rsi*8+0x3], r10b mov r10, rcx shr r10, 0x14 and r10, 0x1f mov byte ptr [r9+rsi*8+0x4], r10b mov r10, rcx shr r10, 0x19 and r10, 0x1f mov byte ptr [r9+rsi*8+0x5], r10b mov r10, rcx shr r11, 0x5 shr r10, 0x1e</pre>	<pre>//constants : __declspec (align(64)) const unsigned __int8 permute_ctrl[64] = { 0, 1, 2, 3, 4, 0, 0, 0 5, 6, 7, 8, 9, 0, 0, 0 10, 11, 12, 13, 14, 0, 0, 0 15, 16, 17, 18, 19, 0, 0, 0 20, 21, 22, 23, 24, 0, 0, 0 25, 26, 27, 28, 29, 0, 0, 0 30, 31, 32, 33, 34, 0, 0, 0 35, 36, 37, 38, 39, 0, 0, 0 }; __declspec (align(64)) const unsigned __int8 multishift_ctrl[64] = { 0, 5, 10, 15, 20, 25, 30, 35 0, 5, 10, 15, 20, 25, 30, 35 0, 5, 10, 15, 20, 25, 30, 35 0, 5, 10, 15, 20, 25, 30, 35 0, 5, 10, 15, 20, 25, 30, 35 0, 5, 10, 15, 20, 25, 30, 35 0, 5, 10, 15, 20, 25, 30, 35 }; //asm: mov rsi, compressedData mov rdi, decompressedData mov r8d, numOfElements lea r8, [rdi+r8] mov r9, 0x1F1F1F1F vpbroadcastd zmm12, r9d vmovdqu32 zmm10, permute_ctrl vmovdqu32 zmm11, multishift_ctrl</pre>

Example 18-23. Improvement with VPMULTISHIFTQB Implementation (Contd.)

<pre>and r11, 0x1f shr rcx, 0x23 and r10, 0x1f and rcx, 0x1f mov byte ptr [r9+rsi*8+0x1], r11b mov byte ptr [r9+rsi*8+0x6], r10b mov byte ptr [r9+rsi*8+0x7], cl inc rsi cmp rsi, rax jb loop</pre>	<pre>loop: vmovdqu32 zmm1, [rsi] vpermb zmm2, zmm10, zmm1 vpmultishiftqb zmm2, zmm11, zmm2 vpandq zmm2, zmm12, zmm2 vmovdqu32 [rdi], zmm2 add rdi, 64 add rsi, 40 cmp rdi, r8 jl loop</pre>
Base Measurement: 1x	Speedup: 26x

18.18 FMA LATENCY

When executing in 512-bit register port scheme, Port 0 FMA has a latency of 4 cycles, and Port 5 FMA has a latency of 6 cycles. Bypass can have a -2 (fast bypass) to +1 cycle delay. Therefore, instructions that execute on the Skylake microarchitecture FMA have a latency of 4-7 cycles.

The instructions are divided into the following two groups.

- Group A Instructions: vadd*; vfmadd*; vfnmsub*; vfnmadd*; vfnmsub*; vmax*; vmin*; vmul*; vscalef*; vsub*; vcvt*; vgetexp*; vfixupimm*; vrang*; vgetmant*; vreduce*; vcmp*, vcomi*, vdpp*, vhadd*, vhsb*, vrndscale*, vround*
- Group B Instructions: vpmaddubsw; vpmaddwd; vpmuldq; vpmulhrsw; vpmulhuw; vpmulhw; vpmullw; vpmuludq

The FMA unit supports fast bypass when all instruction sources come from the FMA unit. In this case Group A has a latency of 4 cycles for both ports 0 and 5, and Group B has a latency of 5 cycles for both ports 0 and 5.

The figure below explains fast bypass when all sources come from the FMA unit.

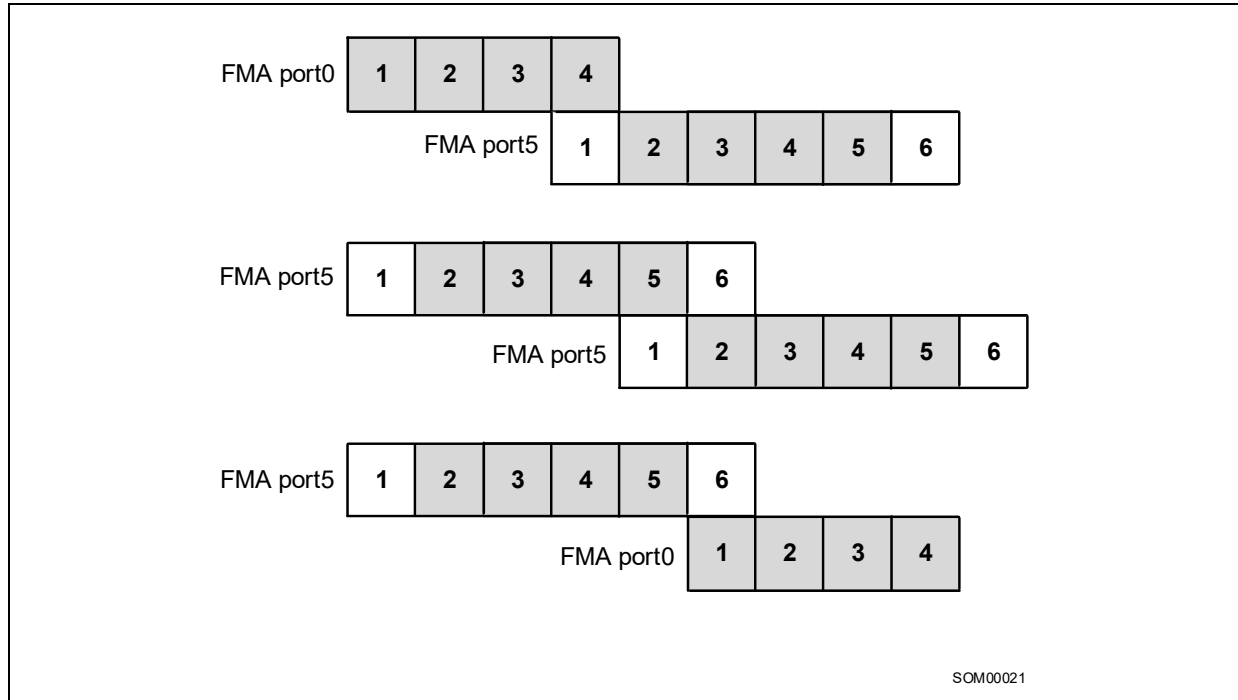

Figure 18-19. Fast Bypass When All Sources Come from FMA Unit

The grey boxes represent compute cycles. The white boxes represent data transfer for the port5 FMA unit.

If fast bypass is not used, that is, when not all sources come from the FMA unit, group A instructions have a latency of 4 cycles on Port0 and 6 cycles on port5, while group B instructions have an additional cycle and hence have a latency of 5 cycles on Port0 and 7 cycles on port5.

The following table summarizes the FMA unit latency for the various options.

Table 18-7. FMA Unit Latency

Instruction Group	Fast Bypass (FMA Data Reuse)		No Fast Bypass (No FMA Data Reuse)	
	Port 0	Port 5	Port 0	Port 5
Group A	4	4	4	6
Group B	5	5	5	7

18.19 MIXING INTEL® AVX EXTENSIONS OR INTEL® AVX-512 EXTENSIONS WITH INTEL® STREAMING SIMD EXTENSIONS (INTEL® SSE) CODE

There are two main instruction groups that affect the processor states:

- Group A: Instruction types that either set bits 128-511 of vector registers 0-15 to zero, or do not modify them at all.
 - Intel SSE instructions.
 - 128-bit Intel AVX instructions, 128-bit Intel AVX-512 instructions.
 - 256-bit (ymm16-ymm31) Intel AVX-512 instructions.

- 512-bit (zmm16-zmm31) Intel AVX-512 instructions.
- AVX-512 instructions that write to mask registers k0-k7.
- GPR instructions.
- Group B: Instructions types that modify bits 128-511 of vector registers 0-15.
 - 256-bit (ymm0-ymm15) Intel AVX instructions, Intel AVX-512 instructions.
 - 512-bit (zmm0-zmm15) Intel AVX-512 instructions.

The following figure illustrates Skylake Server microarchitecture's model for mixing Intel AVX instructions or Intel AVX-512 instructions with Intel SSE instructions.

The implementation is similar to Skylake client microarchitecture, where every Intel SSE instruction executed in Dirty Upper State (2) needs to preserve bits 128-511 of the destination register, and therefore the operation has an additional dependency on the destination register and a blend operation with bits 128-511.

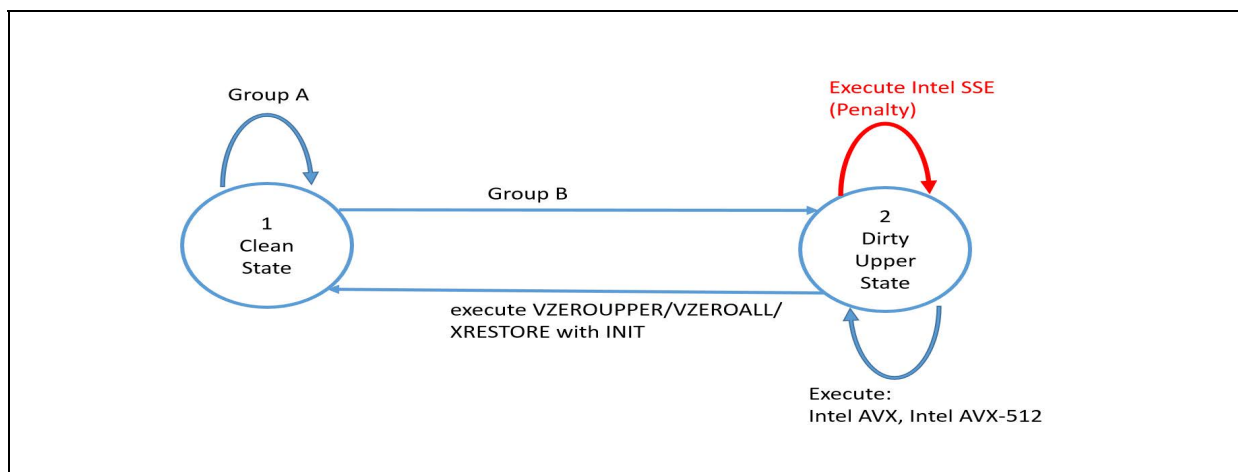

Figure 18-20. Mixing Intel AVX Instructions or Intel AVX-512 Instructions with Intel SSE Instructions

Recommendations:

- When mixing group B instructions with Intel SSE instructions, or suspecting that such a mixture might occur, use the VZEROUPPER instruction whenever a transition is expected.
- Add VZEROUPPER after group B instructions were executed and before any function call that might lead to an Intel SSE instruction execution.
- Add VZEROUPPER at the end of any function that uses group B instructions.
- Add VZEROUPPER before thread creation if not already in a clean state so that the thread does not inherit a Dirty Upper State.

18.20 MIXING ZMM VECTOR CODE WITH XMM/YMM

Skylake microarchitecture has two port schemes, one for using 256-bit or less registers, and another for using 512-bit registers.

When using registers up to or including 256 bits, FMA operations dispatch to ports 0 and 1 and SIMD operations dispatch to ports 0, 1 and 5. When using 512-bit register operations, both FMA and SIMD operations dispatch to ports 0 and 5.

The maximum register width in the reservation station (RS) determines the 256 or 512 port scheme.

Notice that when using AVX-512 encoded instructions with YMM registers, the instructions are considered to be 256-bit wide.

The result of the 512-bit port scheme is that XMM or YMM code dispatches to 2 ports (0 and 5) instead of 3 ports (0, 1, and 5) and may have lower throughput and longer latency compared to the 256-bit port scheme.

Example 18-24. 256-bit Code vs. 256-bit Code Mixed with 512-bit Code

256-bit Code Only	256-bit Code Mixed with 512-bit Code
Loop: vpbroadcastd ymm0, dword ptr [rsp] vfmadd213ps ymm7, ymm7, ymm7 vfmadd213ps ymm8, ymm8, ymm8 vfmadd213ps ymm9, ymm9, ymm9 vfmadd213ps ymm10, ymm10, ymm10 vfmadd213ps ymm11, ymm11, ymm11 vfmadd213ps ymm12, ymm12, ymm12 vfmadd213ps ymm13, ymm13, ymm13 vfmadd213ps ymm14, ymm14, ymm14 vfmadd213ps ymm15, ymm15, ymm15 vfmadd213ps ymm16, ymm16, ymm16 vfmadd213ps ymm17, ymm17, ymm17 vfmadd213ps ymm18, ymm18, ymm18 vpermd ymm1, ymm1, ymm1 vpermd ymm2, ymm2, ymm2 vpermd ymm3, ymm3, ymm3 vpermd ymm4, ymm4, ymm4 vpermd ymm5, ymm5, ymm5 vpermd ymm6, ymm6, ymm6 dec rdx jnle Loop	Loop: vpbroadcastd zmm0, dword ptr [rsp] vfmadd213ps ymm7, ymm7, ymm7 vfmadd213ps ymm8, ymm8, ymm8 vfmadd213ps ymm9, ymm9, ymm9 vfmadd213ps ymm10, ymm10, ymm10 vfmadd213ps ymm11, ymm11, ymm11 vfmadd213ps ymm12, ymm12, ymm12 vfmadd213ps ymm13, ymm13, ymm13 vfmadd213ps ymm14, ymm14, ymm14 vfmadd213ps ymm15, ymm15, ymm15 vfmadd213ps ymm16, ymm16, ymm16 vfmadd213ps ymm17, ymm17, ymm17 vfmadd213ps ymm18, ymm18, ymm18 vpermd ymm1, ymm1, ymm1 vpermd ymm2, ymm2, ymm2 vpermd ymm3, ymm3, ymm3 vpermd ymm4, ymm4, ymm4 vpermd ymm5, ymm5, ymm5 vpermd ymm6, ymm6, ymm6 dec rdx jnle Loop
Baseline 1x	Slowdown: 1.3x

In the 256-bit code only example, the FMAs are dispatched to ports 0 and 1, and *permd* is dispatched to port 5 as the broadcast instruction is 256 bits wide. In the 256-bit and 512-bit mixed code example, the broadcast is 512 bits wide; therefore, the processor uses the 512-bit port scheme where the FMAs dispatch to ports 0 and 5 and *permd* to port 5, thus increasing the pressure on port 5.

18.21 SERVERS WITH A SINGLE FMA UNIT

Some processors based on Skylake microarchitecture have two Intel AVX-512 FMA units, on ports 0 and 5, while other processors based on Skylake microarchitecture have a single Intel AVX-512 FMA unit, which is located on port 0.

Code that is optimized to run on a processor with two FMA units might not be optimal when run on a processor with one FMA unit.

The following example code shows how to detect whether a system has one or two Intel AVX-512 FMA units. It includes the following:

- An Intel AVX-512 warmup.
- A function that executes only FMA instructions.
- A function that executes both FMA and shuffle instructions.

- Code that, based on the results of these two tests, identifies whether the processor has one or two FMA units.

Notice that each test is executed three times to improve test accuracy.

In order to reduce the program overhead, it is highly recommended not to execute this test in every function call, but as part of installation, or once at startup.

The differentiation between the two processors is based on the ratio between the two throughput tests. Processors with two FMA units are able to run the FMA-only test twice as fast as the FMA and shuffle test. However, a processor with one FMA unit will run both tests at the same speed.

Example 18-25. Identifying One or Two FMA Units in a Processor Based on Skylake Microarchitecture

```
#include <string.h>
#include <stdlib.h>
#include <immintrin.h>
#include <stdio.h>
#include <stdint.h>

static uint64_t rdtsc(void) {
    unsigned int ax, dx;

    __asm__ __volatile__ ("rdtsc" : "=a"(ax), "=d"(dx));

    return (((uint64_t)dx) << 32) | ax;
}

uint64_t fma_shuffle_tpt(uint64_t loop_cnt){
    uint64_t loops = loop_cnt;
    __declspec(align(64)) double one_vec[8] = {1, 1, 1, 1, 1, 1, 1, 1};
    __declspec(align(64)) int shuf_vec[16] = {0, 1, 2, 3, 4, 5, 6, 7, 8, 9, 10, 11, 12, 13, 14, 15};
    __asm
    {
        vmovups zmm0, [one_vec]
        vmovups zmm1, [one_vec]
        vmovups zmm2, [one_vec]
    }
}
```

Example 18-25. Identifying One or Two FMA Units in a Processor Based on Skylake Microarchitecture (Contd.)

```

vmovups zmm3, [one_vec]
vmovups zmm4, [one_vec]
vmovups zmm5, [one_vec]
vmovups zmm6, [one_vec]
vmovups zmm7, [one_vec]
vmovups zmm8, [one_vec]
vmovups zmm9, [one_vec]
vmovups zmm10, [one_vec]
vmovups zmm11, [one_vec]
vmovups zmm12, [shuf_vec]
vmovups zmm13, [shuf_vec]
vmovups zmm14, [shuf_vec]
vmovups zmm15, [shuf_vec]
vmovups zmm16, [shuf_vec]
vmovups zmm17, [shuf_vec]
vmovups zmm18, [shuf_vec]
vmovups zmm19, [shuf_vec]
vmovups zmm20, [shuf_vec]
vmovups zmm21, [shuf_vec]
vmovups zmm22, [shuf_vec]
vmovups zmm23, [shuf_vec]
vmovups zmm30, [shuf_vec]
mov rdx, loops
loop1:
vfmadd231pd zmm0, zmm0, zmm0
vfmadd231pd zmm1, zmm1, zmm1
vfmadd231pd zmm2, zmm2, zmm2
vfmadd231pd zmm3, zmm3, zmm3
vfmadd231pd zmm4, zmm4, zmm4
vfmadd231pd zmm5, zmm5, zmm5
vfmadd231pd zmm6, zmm6, zmm6
vfmadd231pd zmm7, zmm7, zmm7
vfmadd231pd zmm8, zmm8, zmm8
vfmadd231pd zmm9, zmm9, zmm9
vfmadd231pd zmm10, zmm10, zmm10
vfmadd231pd zmm11, zmm11, zmm11
vpermd zmm12, zmm30, zmm30
vpermd zmm13, zmm30, zmm30
vpermd zmm14, zmm30, zmm30
vpermd zmm15, zmm30, zmm30
vpermd zmm16, zmm30, zmm30
vpermd zmm17, zmm30, zmm30
vpermd zmm18, zmm30, zmm30
vpermd zmm19, zmm30, zmm30
vpermd zmm20, zmm30, zmm30
vpermd zmm21, zmm30, zmm30
vpermd zmm22, zmm30, zmm30
vpermd zmm23, zmm30, zmm30
dec rdx
jg loop1
}
}

```

Example 18-25. Identifying One or Two FMA Units in a Processor Based on Skylake Microarchitecture (Contd.)

```

uint64_t fma_only_tpt(int loop_cnt){
    uint64_t loops = loop_cnt;
    __declspec(align(64)) double one_vec[8] = {1, 1, 1, 1, 1, 1, 1, 1};
    __asm
    {
        vmovups zmm0, [one_vec]
        vmovups zmm1, [one_vec]
        vmovups zmm2, [one_vec]
        vmovups zmm3, [one_vec]
        vmovups zmm4, [one_vec]
        vmovups zmm5, [one_vec]
        vmovups zmm6, [one_vec]
        vmovups zmm7, [one_vec]
        vmovups zmm8, [one_vec]
        vmovups zmm9, [one_vec]
        vmovups zmm10, [one_vec]
        vmovups zmm11, [one_vec]
        mov rdx, loops
    loop1:
        vfmadd231pd zmm0, zmm0, zmm0
        vfmadd231pd zmm1, zmm1, zmm1
        vfmadd231pd zmm2, zmm2, zmm2
        vfmadd231pd zmm3, zmm3, zmm3
        vfmadd231pd zmm4, zmm4, zmm4
        vfmadd231pd zmm5, zmm5, zmm5
        vfmadd231pd zmm6, zmm6, zmm6
        vfmadd231pd zmm7, zmm7, zmm7
        vfmadd231pd zmm8, zmm8, zmm8
        vfmadd231pd zmm9, zmm9, zmm9
        vfmadd231pd zmm10, zmm10, zmm10
        vfmadd231pd zmm11, zmm11, zmm11
        dec rdx
        jg loop1
    }
}

int main()
{
    int i;
    uint64_t fma_shuf_tpt_test[3];
    uint64_t fma_shuf_tpt_test_min;
    uint64_t fma_only_tpt_test[3];
    uint64_t fma_only_tpt_test_min;
    uint64_t start = 0;
    uint64_t number_of_fma_units_per_core = 2;
}

```

Example 18-25. Identifying One or Two FMA Units in a Processor Based on Skylake Microarchitecture (Contd.)

```

/*****/
/* Step 1: Warmup */
/*****/
fma_only_tpt(100000);

/*****/
/* Step 2: Execute FMA and Shuffle TPT Test */
/*****/

for(i = 0; i < 3; i++){
    start = rdtsc();
    fma_shuffle_tpt(1000);
    fma_shuf_tpt_test[i] = rdtsc() - start;
}

/*****/
/* Step 3: Execute FMA only TPT Test */
/*****/
for(i = 0; i < 3; i++){
    start = rdtsc();
    fma_only_tpt(1000);
    fma_only_tpt_test[i] = rdtsc() - start;
}

/*****/
/* Step 4: Decide if 1 FMA server or 2 FMA server */
/*****/
fma_shuf_tpt_test_min = fma_shuf_tpt_test[0];
fma_only_tpt_test_min = fma_only_tpt_test[0];
for(i = 1; i < 3; i++){
    if ((int)fma_shuf_tpt_test[i] < (int)fma_shuf_tpt_test_min) fma_shuf_tpt_test_min = fma_shuf_tpt_test[i];
    if ((int)fma_only_tpt_test[i] < (int)fma_only_tpt_test_min) fma_only_tpt_test_min = fma_only_tpt_test[i];
}

if(((double)fma_shuf_tpt_test_min/(double)fma_only_tpt_test_min) < 1.5){
    number_of_fma_units_per_core = 1;
}

printf("%d FMA server\n", number_of_fma_units_per_core);
return 0;
}

```

18.22 GATHER/SCATTER TO SHUFFLE (G2S/STS)

18.22.1 Gather to Shuffle in Strided Loads

In cases where there is data locality between gathered elements in memory, performance can be improved by replacing the gather instruction with a software sequence.

This section discusses the very common strided load pattern. Strided loads are sets of loads where the offset in memory between two consecutive loads is constant.

The following examples show three different code variations performing an Array of Structures (AOS) to Structure of Arrays (SOA) transformation. The code separates the real and imaginary elements in a complex array into two separate arrays.

Consider the following C code:

```
for(int i=0;i<len;i++){
    Real_buffer[i] = Complex_buffer[i].real;
    Imaginary_buffer[i] = Complex_buffer[i].imag;
}
```

Example 18-26. Gather to Shuffle in Strided Loads Example

Alternative 1: Intel® AVX-512 vpgatherdd	Alternative 2: G2S Using Intel® AVX-512 vpermi2d
<pre>loop: vpcmpeqb k1, xmm0, xmm0 vpcmpeqb k2, xmm0, xmm0 movsxd rdx, edx movsxd rdi, esi inc esi shl rdi, 0x7 vpxord zmm2, zmm2, zmm2 lea rax, [r8+rdx*8] add edx, 0x20 vpgatherdd zmm2{k1}, [rax+zmm1*4] vpxord zmm3, zmm3, zmm3 vpxord zmm4, zmm4, zmm4 vpxord zmm5, zmm5, zmm5 vpgatherdd zmm3{k2}, [rax+zmm0*4] vpcmpeqb k3, xmm0, xmm0 vpcmpeqb k4, xmm0, xmm0 vmovups [r9+rdi*1], zmm2 vmovups [rcx+rdi*1], zmm3 vpgatherdd zmm4{k3}, [rax+zmm1*4+0x80] vpgatherdd zmm5{k4}, [rax+zmm0*4+0x80] vmovups [r9+rdi*1+0x40], zmm4 vmovups [rcx+rdi*1+0x40], zmm5 cmp esi, r14d jb loop</pre>	<pre>vmovups zmm4, [rdx+r9*8] vmovups zmm0, [rdx+r9*8+0x40] vmovups zmm5, [rdx+r9*8+0x80] vmovups zmm1, [rdx+r9*8+0xc0] vmovaps zmm2, zmm7 vmovaps zmm3, zmm7 vpermi2d zmm2, zmm4, zmm0 vpermt2d zmm4, zmm6, zmm0 vpermi2d zmm3, zmm5, zmm1 vpermt2d zmm5, zmm6, zmm1 vmovdqu32 [rcx+r9*4], zmm2 vmovdqu32 [rcx+r9*4+0x40], zmm3 vmovdqu32 [r8+r9*4], zmm4 vmovdqu32 [r8+r9*4+0x40], zmm5 add r9, 0x20 cmp r9, r10 jb loop</pre>
Baseline 1x	Speedup: 4.8x

The following constants were loaded into zmm registers and used as gather and permute indices:

Zmm0 (Alternative 1), zmm6 (Alternative 2)

```
__declspec (align(64)) const __int32 gather_imag_index[16] = {1, 3, 5, 7, 9, 11, 13, 15, 17, 19, 21, 23, 25, 27, 29, 31};
```

Zmm1 (Alternative 1), zmm7 (Alternative 2)

```
__declspec (align(64)) const __int32 gather_real_index[16] = {0, 2, 4, 6, 8, 10, 12, 14, 16, 18, 20, 22, 24, 26, 28, 30};
```

Recommendation: For best performance, replace strided loads where the stride is short, with a sequence of loads and permutes.

18.22.2 Scatter to Shuffle in Strided Stores

The following is an Scatter to Shuffle example that replaces scatter with permute and store instructions

Consider the following C code:

```
for(int i=0;i<len;i++){
    Complex_buffer[i].real = Real_buffer[i];
    Complex_buffer[i].imag = Imaginary_buffer[i];
}
```

Example 18-27. Gather to Shuffle in Strided Stores Example

Alternative 1: Intel® AVX-512 vscatterdps	Alternative 2: S2S using Intel® AVX-512 vpermi2d
<pre>loop: vpcmpeqb k1, xmm0, xmm0 lea r11, [r8+rcx*4] vpcmpeqb k2, xmm0, xmm0 vmovups zmm2, [rax+rsi*4] vmovups zmm3, [r9+rsi*4] vscatterdps [r11+zmm1*4][k1], zmm2 vscatterdps [r11+zmm0*4][k2], zmm3 add rsi, 0x10 add rcx, 0x20 cmp rsi, r10 jl loop</pre>	<pre>loop: vmovups zmm4, [rax+r8*4] vmovups zmm2, [r10+r8*4] vmovaps zmm3, zmm1 add r8, 0x10 vpermi2d zmm3, zmm4, zmm2 vpermt2d zmm4, zmm0, zmm2 vmovups [r9+rsi*4], zmm3 vmovups [r9+rsi*4+0x40], zmm4 add rsi, 0x20 cmp r8, r11 jl loop</pre>
Baseline 1x	Speedup: 4.4x

The following constants were used as scatter indices:

Zmm1:

```
__declspec (align(64)) const __int32 scatter_real_index[16] = {0, 2, 4, 6, 8, 10, 12, 14, 16, 18, 20, 22, 24, 26, 28, 30};
```

Zmm0:

```
__declspec (align(64)) const __int32 scatter_imag_index[16] = {1, 3, 5, 7, 9, 11, 13, 15, 17, 19, 21, 23, 25, 27, 29, 31};
```

The following constants were used as permute indices:

Zmm1:

```
__declspec (align(64)) const __int32 first_half[16] = {0, 16, 1, 17, 2, 18, 3, 19, 4, 20, 5, 21, 6, 22, 7, 23};
```

Zmm0:

```
__declspec (align(64)) const __int32 second_half[16] = {8, 24, 9, 25, 10, 26, 11, 27, 12, 28, 13, 29, 14, 30, 15, 31};
```

18.22.3 Gather to Shuffle in Adjacent Loads

In cases where the gathered elements are grouped into adjacent sequences, the gather instruction can be replaced by a software sequence to improve performance.

The following example shows how to load vectors when elements are adjacent.

Notice that in this case the order of the elements in the arrays is set according to an index buffer and therefore the software optimization discussed in Section 18.22.1, “Gather to Shuffle in Strided Loads” is not applicable in this case.

Consider the following C code:

```
typedef struct{
    double var[4];
} ElemStruct;

const int* indices = Indices;
const ElemStruct *in = (const ElemStruct*) InputBuffer;
double* restrict out = OutputBuffer;

for (int i = 0; i < width; i++){
    for (int j = 0; j < 4; j++){
        out[i*4+j] = in[indices[i]].var[j];
    }
}
```

Example 18-28. Gather to Shuffle in Adjacent Loads Example

Alternative 1: vgatherdpd Implementation	Alternative 2: Load and Masked broadcast
<pre> loop: vpbroadcastd ymm3, [r9+rsi*4] mov r15d, esi vpbroadcastd xmm2, [r9+rsi*4+0x4] add rsi, 0x2 vpbroadcastd ymm3{k1}, xmm2 vpmulld ymm4, ymm3, ymm1 vpadd ymm5, ymm4, ymm0 vpcmpeqb k2, xmm0, xmm0 shl r15d, 0x2 movsxd r15, r15d vpxord zmm6, zmm6, zmm6 vgatherdpd zmm6{k2}, [r10+ymm5*1] vmovups [r11+r15*8], zmm6 cmp rsi, rdi jl loop </pre>	<pre> loop: movsxd r11, [r10+rcx*4] shl r11, 0x5 vmovupd ymm0, [r9+r11*1] movsxd r11, [r10+rcx*4+0x4] shl r11, 0x5 vbroadcastf64x4 zmm0{k1}, [r9+r11*1] mov r11d, ecx shl r11d, 0x2 add rcx, 0x2 movsxd r11, r11d vmovups [r8+r11*8], zmm0 cmp rcx, rsi jl loop </pre>
Baseline 1x	Speedup: 2.2x

The following constants were used in the vgatherdpd implementation:

ymm0:

```
__declspec (align(64)) const __int32 index_inc[8] = {0, 8, 16, 24, 0, 8, 16, 24};
```

ymm1:

```
__declspec (align(64)) const __int32 index_scale[8] = {32, 32, 32, 32, 32, 32, 32, 32};
```

K1 register value is 0xF0.

18.23 DATA ALIGNMENT

This section explains the benefit of aligning data when using the Intel AVX-512 instructions and proposes some methods to improve performance when such alignment is not possible. Most examples in this section are variations of the SAXPY kernel. SAXPY is the Scalar Alpha * X + Y algorithm.

The C code below is a C implementation of SAXPY.

```

for (int i = 0; i < n; i++)
{
c[i] = alpha * a[i] + b[i];
}

```

18.23.1 Align Data to 64 Bytes

Aligning data to vector length is recommended. For best results, when using Intel AVX-512 instructions, align data to 64-bytes.

When doing a 64-byte Intel AVX-512 unaligned load/store, every load/store is a cache-line split, since the cache-line is 64 bytes. This is double the cache line split rate of Intel AVX2 code that uses 32-byte registers. A high cache-line split rate in memory-intensive code can cause poor performance.

The following table shows how the performance of the memory intensive SAXPY code is affected by misaligning input and output buffers. The data in the table is based on the following code.

Example 18-29. Data Alignment

```

__asm {
    mov rax, src1
    mov rbx, src2
    mov rcx, dst
    mov rdx, len
    xor rdi, rdi
    vbroadcastss zmm0, alpha
mainloop:
    vmovups zmm1, [rax]
    vfmadd213ps zmm1, zmm0, [rbx]
    vmovups [rcx], zmm1

    vmovups zmm1, [rax+0x40]
    vfmadd213ps zmm1, zmm0, [rbx+0x40]
    vmovups [rcx+0x40], zmm1

    vmovups zmm1, [rax+0x80]
    vfmadd213ps zmm1, zmm0, [rbx+0x80]
    vmovups [rcx+0x80], zmm1

    vmovups zmm1, [rax+0xC0]
    vfmadd213ps zmm1, zmm0, [rbx+0xC0]
    vmovups [rcx+0xC0], zmm1

    add rax, 256
    add rbx, 256
    add rcx, 256
    add rdi, 64
    cmp rdi, rdx
    jl mainloop
}

```

The following table summarizes the data alignment effects on SAXPY performance with speedup values for the various options.

Table 18-8. Data Alignment Effects on SAXPY Performance vs. Speedup Value

Data Alignment Effects on SAXPY Performance	Speedup
Alternative 1: Both sources and the destination are 64-byte aligned.	Baseline, 1.0
Alternative 2: Both sources are 64-byte aligned, destination has a 4 byte offset from the alignment.	0.66x
Alternative 3: Both sources and the destinations have 4 bytes offset from the alignment.	0.59x
Alternative 4: One source has a 4 byte offset from the alignment, the other source and the destination are 64-byte aligned.	0.77x

18.24 DYNAMIC MEMORY ALLOCATION AND MEMORY ALIGNMENT

Consider the following structure:

```
float3_SOA {
    __declspec(align(64)) float x[16];
    __declspec(align(64)) float y[16];
};
```

The memory allocated for the structure is aligned to 64 bytes if you use this structure as follows:

```
float3_SOA f;
```

However, if you use dynamic memory allocation as follows, the `declspec` directive is ignored and the 64-byte memory alignment is not guaranteed:

```
float3_SOA* stPtr = new float3_SOA();
```

In this case, you should use dynamic aligned memory allocation and/or redefine operator `new`.

Recommendation: Align data to 64 bytes, when possible, using the following guidelines.

- Use dynamic data alignment using the `_mm_malloc` intrinsic instruction with the Intel® Compiler, or `_aligned_malloc` of the Microsoft* Compiler. For example:

```
//dynamically allocating 64byte aligned buffer with 2048 float elements.
InputBuffer = (float*) _mm_malloc (2048*sizeof(float), 64);
```

- Use static data alignment using `__declspec(align(64))`. For example:

```
//Statically allocating 64byte aligned buffer with 2048 float elements.
__declspec(align(64)) float InputBuffer[2048];
```

18.25 DIVISION AND SQUARE ROOT OPERATIONS

It is possible to speed up single-precision divide and square root calculations using the `VRSQRT14PS/VRSQRT14PD` and `VRCP14PS/VRCP14PD` instructions. These instructions yield an approximation (with 14 bits accuracy) of the Reciprocal Square Roots / Reciprocal Divide of their input.

The Intel AVX-512 implementation of these instructions is pipelined and has:

- For 256-bit vectors: latency of 4 cycles with a throughput of one instruction every cycle.
- For 512-bit vectors: latency of 6 cycles with a throughput of one instruction every 2 cycles.

Skylake microarchitecture introduces the packed-double (PD) variants of reciprocal square-root and reciprocal divide: `VRSQRT14PD` and `VRCP14PD` (respectively).

The `VRSQRT14PS/VRSQRT14PD` and `VRCP14PS/VRCP14PD` instructions can be used with a single Newton-Raphson iteration or other polynomial approximation to achieve almost the same precision as the `VDIVPS` and `VSQRTPS` instructions (see the Intel® 64 and IA-32 Architectures Software Developer's Manuals for more information on these instructions), and may yield a much higher throughput.

If the full precision (IEEE) must be maintained, a low latency and high throughput can be achieved due to the significant performance improvement of the Skylake microarchitecture to `DIVPS` and `SQRTPS`, comparing to their performance on previous microarchitectures. This is illustrated in Figure 18-11.

NOTE

In some cases, when the divide or square root operations are part of a larger algorithm that hides some of the latency of these operations, the approximation with Newton-Raphson can slow down execution, because more micro-ops, coming from the additional instructions, fill the pipe.

The following sections show the operations with recommended calculation methods depending on the desired accuracy level.

NOTE

There are two definitions for approximation error of a value and it's approximation

V_{approx} :

Absolute error = $|v - v_{\text{approx}}|$

Relative error = $|v - v_{\text{approx}}| / |v|$

In this chapter, the “number of bits” error is relative, and not the error of absolute values.

The value v to which we compare our approximation should be as accurate as possible, better double accuracy.

18.25.1 Divide and Square Root Approximation Methods

Table 18-9. Skylake Microarchitecture Recommendations for DIV/SQRT Based Operations (Single Precision)

Operation	Accuracy	Recommended Method
Divide	24 bits (IEEE)	DIVPS
	23 bits	RCP14PS + MULPS + 1 Newton-Raphson iteration
	14 bits	RCP14PS + MULPS
Reciprocal Square Root	22 bits	SQRTPS + DIVPS
	23 bits	RSQRT14PS + 1 Newton-Raphson iteration
	14 bits	RSQRT14PS
Square Root	24 bits (IEEE)	SQRTPS
	23 bits	RSQRT14PS + MULPS + 1 Newton-Raphson iteration
	14 bits	RSQRT14PS + MULPS

Table 18-10. Skylake Microarchitecture Recommendations for DIV/SQRT Based Operations (Double Precision)

Operation	Accuracy	Recommended Method
Divide	53 bits (IEEE)	DIVPD
	52 bits	RCP14PD + MULPD + 2 Newton-Raphson iterations
	26 bits	RCP14PD + MULPD + 1 Newton-Raphson iterations
	14 bits	RCP14PD + MULPD

Table 18-10. Skylake Microarchitecture Recommendations for DIV/SQRT Based Operations (Double Precision)

Reciprocal Square Root	53 bits (IEEE)	SQRTPD + DIVPD
	52 bits	RSQRT14PD+2 N-R + error correction or SQRTPD + DIVPD
	50 bits	RSQRT14PD + Polynomial approximation
	26 bits	RSQRT14PD+1 N-R
	14 bits	RSQRT14PD
Square Root	51 bits (IEEE)	SQRTPD
	52 bits	RSQRT14PD + MULPD + Polynomial approximation
	26 bits	RSQRT14PD + MULPD + 1 N-R
	14 bits	RSQRT14PD + MULPD

18.25.2 Divide and Square Root Performance

Performance of vector divide and square root operations on Broadwell and Skylake microarchitectures is shown below.

Table 18-11. 256-bit Intel AVX2 Divide and Square Root Instruction Performance

Broadwell Microarchitecture	DIVPS	SQRTPS	DIVPD	SQRTPD
Latency	17	21	23	35
Throughput	10	14	16	28
Skylake Microarchitecture	DIVPS	SQRTPS	DIVPD	SQRTPD
Latency	11	12	14	18
Throughput	5	6	8	12

Table 18-12. 512-bit Intel AVX-512 Divide and Square Root Instruction Performance

Skylake Microarchitecture	DIVPS	SQRTPS	DIVPD	SQRTPD
Latency	17	19	23	31
Throughput	10	12	16	24

18.25.3 Approximation Latencies

This section shows the latency and throughput for the approximation methods, and DIV and SQRT instructions. The tables below show that in most cases the throughput gain of the approximation methods is (at least) double that of their IEEE counterparts, in simple loops that compute division or square root.

The throughput benefits of approximation sequences are diminished when the loop iterations contain a lot of other computation (besides divide or square root).

As a rule of thumb, approximations of near-IEEE accuracy are recommended when the loop iteration contains no more than 8-10 additional single precision operations, or no more than 12-15 additional double precision operations. The tables below show that these accurate approximations are beneficial for

throughput optimizations only. The less accurate approximations can help with latency, as well as throughput.

It should also be mentioned that Newton-Raphson approximations do not handle the following special cases correctly: denormal inputs, zeroes, or Infinities. Some sequences also lose accuracy for near-denormal inputs, due to underflow in intermediate steps. While zero and Infinity inputs are relatively easy to fix with a few additional operations (as done in some of the sequences below), denormal divisors cannot be addressed without significant performance impact. The approximation sequences work best for “middle-of-the-range” inputs that are not close to overflow or underflow thresholds.

The table below shows the latency and throughput of single precision Intel AVX-512 divide and square root instructions, compared to the approximation methods on Skylake microarchitecture.

Table 18-13. Latency/Throughput of Different Methods of Computing Divide and Square Root on Skylake Microarchitecture for Different Vector Widths, on Single Precision

Operation	Method	Accuracy	256-bit Intel® AVX-512 Instructions		512-bit Intel® AVX-512 Instructions	
			Throughput	Latency	Throughput	Latency
Divide (a/b)	DIVPS	24 bits (IEEE)	5	11	10	17
	RCP14PS + MULPS + 1 Newton-Raphson Iteration	23 bits	2	16	3	20
	RCP14PS + MULPS	14 bits	1	8	2	10-12
Square root	SQRTPS	24 bits (IEEE)	6	12	12	19
	RSQRT14PS + MULPS + 1 Newton-Raphson Iteration	23 bits	3	16	5	20
	RSQRT14PS + MULPS	14 bits	2	9	3	12
Reciprocal square root	SQRTPS + DIVPS	22 bits	11	23	22	36
	RSQRT14PS + 1 Newton-Raphson Iteration	23 bits	3.67	20	4.89	25
	RSQRT14PS	14 bits	1	4	2	6

Table 18-14. Latency/Throughput of Different Methods of Computing Divide and Square Root on Skylake Microarchitecture for Different Vector Widths, on Double Precision

Operation	Method	Accuracy	256-bit Intel® AVX-512 Instructions		512-bit Intel® AVX-512 Instructions	
			Throughput	Latency	Throughput	Latency
Divide (a/b)	DIVPD	53 bits (IEEE)	8	14	16	23
	RCP14PD + MULPD + 2 Newton-Raphson Iterations	22 bits	3.2	27	4.7	28.4
	RCP14PD + MULPD + 1 Newton-Raphson Iteration	26 bits	2	16	3	20
	RCP14PD + MULPD	14 bits	1	8	2	10-12
Square root	SQRTPD	53 bits (IEEE)	12	18	24	31
	RSQRT14PD + MULPD + Polynomial Approximation	22 bits	4.82	24.54 ¹	6.4	28.48 ¹
	RSQRT14PD + MULPD + 1 N-R	26 bits	3.76	17	5	20
	RSQRT14PD + MULPD	14 bits	2	9	3	12
Reciprocal square root	SQRTPD + DIVPD	51 bits	20	32	40	53
	RSQRT14PD + 2-NR + error correction	52 bits	5	29.38	6.53	34
	RSQRT14PD+2 N-R	50 bits	3.79	25.73	5.51	30
	RSQRT14PD+1 N-R	26 bits	2.7	18	4.5	21.67
	RSQRT14PD	14 bits	1	4	2	6

NOTES:

1. These numbers are not rounded because their code sequence contains several FMA (Fused-multiply-add) instructions, which have a varying latency of 4/6. Therefore the latency for these sequences is not necessarily fixed.

18.25.4 Code Snippets

Example 18-30. Vectorized 32-bit Float Division

Single Precision, Divide, 24 Bits (IEEE)	
<pre>float a = 10; float b = 5; __asm { vbroadcastss zmm0, a // fill zmm0 with 16 elements of a vbroadcastss zmm1, b // fill zmm1 with 16 elements of b vdivps zmm2, zmm0, zmm1 // zmm2 = 16 elements of a/b }</pre>	
Single Precision, Divide, 23 Bits	Single Precision, Divide, 14 Bits
<pre>/* Input: zmm0 = vector of a's zmm1 = vector of b's Output: zmm3 = vector of a/b */ __asm { vrcp14ps zmm2, zmm1 vmulps zmm3, zmm0, zmm2 vmovaps zmm4, zmm0 vfnmadd231ps zmm4, zmm3, zmm1 vfmadd231ps zmm3, zmm4, zmm2 }</pre>	<pre>/* Input: zmm0 = vector of a's zmm1 = vector of b's Output: zmm2 = vector of a/b */ __asm { vrcp14ps zmm2, zmm1 vmulps zmm2, zmm0, zmm2 }</pre>

Example 18-31. Reciprocal Square Root

Single Precision, Reciprocal Square Root, 22 Bits	
<pre> /* Input: zmm0 = vector of a's zmm1 = vector of 1's Output: zmm2 = vector of 1/sqrt (a) */ float one = 1.0; __asm { vbroadcastss zmm1, one // zmm1 = vector of 16 1's vsqrtps zmm2, zmm0 vdivps zmm2, zmm1, zmm2 } </pre>	
Single Precision, Reciprocal Square Root, 23 Bits	Single Precision, Reciprocal Square Root, 14 Bits
<pre> /* Input: zmm0 = vector of a's Output: zmm2 = vector of 1/sqrt (a) */ float half = 0.5; __asm { vbroadcastss zmm1, half // zmm1 = vector of 16 0.5's vrsqrt14ps zmm2, zmm0 vmulps zmm3, zmm0, zmm2 vmulps zmm4, zmm1, zmm2 vfmadd231ps zmm1, zmm3, zmm4 vfmsub231ps zmm3, zmm0, zmm2 vfmadd231ps zmm1, zmm4, zmm3 vfmadd231ps zmm2, zmm2, zmm1 } </pre>	<pre> /* Input: zmm0 = vector of a's Output: zmm2 = vector of 1/sqrt (a) */ __asm { vrsqrt14ps zmm2, zmm0 } </pre>

Example 18-32. Square Root

Single Precision, Square Root, 24 Bits (IEEE)	
<pre> /* Input: zmm0 = vector of a's Output: zmm2 = vector of sqrt (a) */ __asm { vsqrtps zmm2, zmm0 } </pre>	
Single Precision, Square Root, 23 Bits	Single Precision, Square Root, 14 Bits
<pre> /* Input: zmm0 = vector of a's Output: zmm0 = vector of sqrt (a) */ float half = 0.5; __asm { vbroadcastss zmm3, half vrsqrt14ps zmm1, zmm0 vfpclassps k2, zmm0, 0xe vmulps zmm2, zmm0, zmm1, {rn-sae} vmulps zmm1, zmm1, zmm3 knotw k3, k2 vfnmadd231ps zmm0{k3}, zmm2, zmm2 vfmadd213ps zmm0{k3}, zmm1, zmm2 } </pre>	<pre> /* Input: zmm0 = vector of a's Output: zmm0 = vector of sqrt (a) */ __asm { vrsqrt14ps zmm1, zmm0 vfpclassps k2, zmm0, 0xe knotw k3, k2 vmulps zmm0{k3}, zmm0, zmm1 } </pre>

Example 18-33. Dividing Packed Doubles

Double Precision, Divide, 53 Bits (IEEE)	Double Precision, Divide, 52 Bits
<pre data-bbox="198 336 511 651"> /* Input: zmm0 = vector of a's zmm1 = vector of b's Output: zmm2 = vector of a/b */ __asm { vdivpd zmm2, zmm0, zmm1 } </pre>	<pre data-bbox="824 336 1356 1029"> /* Input: zmm15 = vector of a's zmm0 = vector of b's Output: zmm0 = vector of a/b */ double One = 1.0; __asm { vrcp14pd zmm1, zmm0 vmovapd zmm4, zmm0 vbroadcastsd zmm2, one vfmadd213pd zmm0, zmm1, zmm2, {rn-sae} vfpclasspd k2, zmm1, 0x1e vfmadd213pd zmm0, zmm1, zmm1, {rn-sae}} knotw k3, k2 vfmadd213pd zmm4, zmm0, zmm2, {rn-sae} vblendmpd zmm0 {k2}, zmm0, zmm1 vfmadd213pd zmm0 {k3}, zmm4, zmm0, {rn-sae} vmulpd zmm0, zmm0, zmm15 } </pre>
Double Precision, Divide, 26 Bits	Double Precision, Divide, 14 Bits
<pre data-bbox="198 1100 600 1539"> /* Input: zmm0 = vector of a's zmm1 = vector of b's Output: zmm3 = vector of a/b */ __asm { vrcp14pd zmm2, zmm1 vmulpd zmm3, zmm0, zmm2 vmovapd zmm4, zmm0 vfmadd231pd zmm4, zmm3, zmm1 vfmadd231pd zmm3, zmm4, zmm2 } </pre>	<pre data-bbox="824 1100 1149 1449"> /* Input: zmm0 = vector of a's zmm1 = vector of b's Output: zmm2 = vector of a/b */ __asm { vrcp14pd zmm2, zmm1 vmulpd zmm2, zmm0, zmm2 } </pre>

Example 18-34. Reciprocal Square Root of Doubles

Double Precision, Reciprocal Square Root, 51 Bits	
<pre> /* Input: zmm0 = vector of a's zmm1 = vector of 1's Output: zmm0 = vector of 1/sqrt (a) */ __asm { vsqrtpd zmm0, zmm0 vdivpd zmm0, zmm1, zmm0 } </pre>	
Double Precision, Reciprocal Square Root, 52 Bits	Double Precision, Reciprocal Square Root, 50 Bits
<pre> /* Input: zmm4 = vector of a's Output: zmm0 = vector of 1/sqrt (a) */ // duplicates x eight times #define DUP8_DECL(x) x, x, x, x, x, x, x, x // used for aligning data structures to n bytes #define ALIGNTO(n) __declspec(align(n)) ALIGNTO(64) __int64 one[] = {DUP8_DECL(0x3FF0000000000000)}; ALIGNTO(64) __int64 dc1[] = {DUP8_DECL(0x3FE0000000000000)}; ALIGNTO(64) __int64 dc2[] = {DUP8_DECL(0x3FD8000004600001)}; ALIGNTO(64) __int64 dc3[] = {DUP8_DECL(0x3FD4000005E80001)}; __asm { vbroadcastsd zmm4, big_num vmovapd zmm0, one vmovapd zmm5, dc1 vmovapd zmm6, dc2 vmovapd zmm7, dc3 vrsqrt14pd zmm3, zmm4 vfpclasspd k1, zmm4, 0x5e vmulpd zmm1, zmm3, zmm4, {rn-sae} vfnmadd231pd zmm0, zmm3, zmm1 vfmsub231pd zmm1, zmm3, zmm4, {rn-sae} vfnmadd213pd zmm1, zmm3, zmm0 vmovups zmm0, zmm7 vmulpd zmm2, zmm3, zmm1 vfmadd213pd zmm0, zmm1, zmm6 vfmadd213pd zmm0, zmm1, zmm5 vfmadd213pd zmm0, zmm2, zmm3 vorpd zmm0{k1}, zmm3, zmm3 } </pre>	<pre> /* Input: zmm3 = vector of a's Output: zmm4 = vector of 1/sqrt (a) */ // duplicates x eight times #define DUP8_DECL(x) x, x, x, x, x, x, x, x // used for aligning data structures to n bytes #define ALIGNTO(n) __declspec(align(n)) ALIGNTO(64) __int64 one[] = {DUP8_DECL(0x3FF0000000000000)}; ALIGNTO(64) __int64 dc1[] = {DUP8_DECL(0x3FE0000000000000)}; ALIGNTO(64) __int64 dc2[] = {DUP8_DECL(0x3FD8000004600001)}; ALIGNTO(64) __int64 dc3[] = {DUP8_DECL(0x3FD4000005E80001)}; __asm { vmovapd zmm5, one vmovapd zmm6, dc1 vmovapd zmm8, dc3 vmovapd zmm7, dc2 vrsqrt14pd zmm2, zmm3 vfpclasspd k1, zmm3, 0x5e vmulpd zmm0, zmm2, zmm3, {rn-sae} vfnmadd231pd zmm0, zmm2, zmm5 vmulpd zmm1, zmm2, zmm0 vmovapd zmm4, zmm8 vfmadd213pd zmm4, zmm0, zmm7 vfmadd213pd zmm4, zmm0, zmm6 vfmadd213pd zmm4, zmm1, zmm2 vorpd zmm4{k1}, zmm2, zmm2 } </pre>

Example 18-34. Reciprocal Square Root of Doubles (Contd.)

Double Precision, Reciprocal Square Root, 26 Bits	Double Precision, Reciprocal Square Root, 14 Bits
<pre> /* Input: zmm0 = vector of a's Output: zmm1 = vector of 1/sqrt (a) */ double half = 0.5; __asm { vrsqrt14pd zmm1, zmm0 vmulpd zmm0, zmm0, zmm1 vbroadcastsd zmm3, half vmulpd zmm2, zmm1, zmm3 vfmadd213pd zmm2, zmm0, zmm3 vfmadd213pd zmm1, zmm2, zmm1 } </pre>	<pre> /* Input: zmm0 = vector of a's Output: zmm2 = vector of 1/sqrt (a) */ __asm { vrsqrt14pd zmm2, zmm0 } </pre>

Example 18-35. Square Root of Packed Doubles

Double Precision, Square Root, 53 Bits (IEEE)	Double Precision, Square Root, 52 Bits
<pre> /* Input: zmm0 = vector of a's Output: zmm2 = vector of sqrt (a) */ __asm { vsqrtpd zmm2, zmm0 } </pre>	<pre> /* Input: zmm0 = vector of a's Output: zmm0 = vector of sqrt (a) */ double half = 0.5; __asm { vbroadcastsd zmm4, half vrsqrt14pd zmm1, zmm0 vfpclasspd k2, zmm0, 0xe vmulpd zmm2, zmm0, zmm1, {rn-sae} vmulpd zmm1, zmm1, zmm4 knotw k3, k2 vmovapd zmm3, zmm4 vfmadd231pd zmm3, zmm1, zmm2, {rn-sae} vfmadd213pd zmm2, zmm3, zmm2, {rn-sae} vfmadd213pd zmm1, zmm3, zmm1, {rn-sae} vfmadd231pd zmm0 {k3}, zmm2, zmm2, {rn-sae} vfmadd213pd zmm0 {k3}, zmm1, zmm2 } </pre>

Example 18-35. Square Root of Packed Doubles (Contd.)

Double Precision, Square Root, 26 Bits	Double Precision, Square Root, 14 Bits
<pre> /* Input: zmm0 = vector of a's Output: zmm0 = vector of sqrt (a) */ // duplicates x eight times #define DUP8_DECL(x) x, x, x, x, x, x, x, x // used for aligning data structures to n bytes #define ALIGNTO(n) __declspec(align(n)) ALIGNTO(64) __int64 OneHalf[] = {DUP8_DECL(0X3FE0000000000000)}; __asm { vrsqrt14pd zmm1, zmm0 vfpclasspd k2, zmm0, 0xe knotw k3, k2 vmulpd zmm0 {k3}, zmm0, zmm1 vmulpd zmm1, zmm1, ZMMWORD PTR [OneHalf] vfmadd213pd zmm1, zmm0, ZMMWORD PTR [OneHalf] vfmadd213pd zmm0 {k3}, zmm1, zmm0 } </pre>	<pre> /* Input: zmm0 = vector of a's Output: zmm0 = vector of sqrt (a) */ __asm { vrsqrt14pd zmm1, zmm0 vfpclasspd k2, zmm0, 0xe knotw k3, k2 vmulpd zmm0 {k3}, zmm0, zmm1 } </pre>

18.26 CLDEMOTE

Using the CLDEMOTE instruction, a processor puts a cache line into the last shared level of the cache hierarchy so that other CPU cores 'find' the same cache line in the last shared level and expensive cross-core snoop is avoided. The most significant advantage of CLDEMOTE is that multiple consumers can access the shared cache line amortizing each snoop request portion.

18.26.1 Producer-Consumer Communication in Software

In a multiprocessor environment, data sharing between the producers and consumers is an undisputed event. A cache hierarchy solves the major problem of accessing the line from the main memory resulting in faster data transfers. Typical cache hierarchy contains:

- Private L1 data and L1 instruction cache.
- A shared L2 cache for sibling hardware thread.
- A common L3 cache for all the CPU cores.

When a producer consumes data from the I/O or produces it, it is brought into the producer's L1 cache. Consumers read the data by initiating read requests, translating it into cross-core snoops, request, and response events. Consumers report L3 cache miss events and producer cores responding to the consumer core's snoop request. Multiplexing these cross-cores requests and responses when dealing with multiple consumers is detrimental.

18.27 TIPS ON COMPILER USAGE

This section explains some of the important compiler options that can be used with the Intel compiler to derive the best performance on a Skylake server. For complete information on the compiler options and tuning tips, see the main product documentation at: <https://software.intel.com/en-us/intel-software-technical-documentation>. For example, the Intel® C++ Compiler 17.0 Developer Guide and Reference can be found here: <https://software.intel.com/en-us/intel-cplusplus-compiler-17.0-user-and-reference-guide>.

Many options have names that are the same on Linux* and Windows*, except that the Windows* form starts with an initial Q. Within text, such option names are shown as [Q]option-name.

The default optimization level is O2 (unless -g is specified, in which case the default is O0). Level O2 enables many compiler optimizations including vectorization. Optimization level O3 is recommended for loop-intensive and HPC applications, as it enables more aggressive loop and memory-access optimizations, such as loop fusion and loop blocking to allow more efficient use of the caches.

For best performance on Skylake server microarchitecture, applications should be compiled with the processor-specific option [Q]xCORE-AVX512. Note that an executable compiled with these options will not run on non-Intel processors or on Intel processors that support only lower instruction sets.

For users who want to generate a common binary that can be executed on Skylake server microarchitecture and the Intel® Xeon Phi™ processors based on Knights Landing microarchitecture, use the option [Q]xCOMMON-AVX512. Note that this option has a performance cost on both Skylake server microarchitecture and Intel® Xeon Phi™ processors compared with executables generated with the target-specific options [Q]xCORE-AVX512 on Skylake server, and [Q]xMIC-AVX512 on Intel® Xeon Phi™ processors.

In addition, users can tune the zmm code generation done by the compiler for Skylake server microarchitecture using the additional option -qopt-zmm-usage=low|high (/Qopt-zmm-usage:low|high on Windows). The argument value of low provides a smooth transition experience from AVX2 ISA to AVX512 ISA on a Skylake server microarchitecture target, such as for enterprise applications. Tuning for ZMM instruction use via explicit vector syntax such as #pragma omp simd simdlen() is recommended. The argument value of high is recommended for applications, such as HPC codes, that are bounded by vector computation to achieve more compute per instruction through use of the wider vector operations. The default value is low for Skylake server microarchitecture-family compilation targets, such as [Q]xCORE-AVX512 and high for CORE/MIC AVX512 combined compilation targets such as [Q]xCOMMON-AVX512.

It is also possible to generate a fat binary that supports multiple instruction sets by using the [Q]xtarget option. For example, if the application is compiled with [Q]axCORE-AVX512,CORE-AVX2 the compiler might generate specialized code for the Skylake server microarchitecture and AVX2 targets, while also generating a default code path that will run on any Intel or compatible, non-Intel processor that supports at least Intel® Streaming SIMD Extensions 2 (Intel® SSE2). At runtime, the application automatically detects whether it is running on an Intel processor. If so, it selects the most appropriate code path for Intel processors; if not, the default code path is selected. It is also important to note that irrespective of the options used, the compiler might insert calls into specialized library routines, such as optimized versions of memset/memcpy, that will dispatch to the appropriate codepath at runtime based on processor detection.

The option -qopt-report[n] (/Qopt-report[:n] on Windows) generates a report on the optimizations performed by the compiler, by default it is written to a file with a .oprpt file extension. n specifies the level of detail, from 0 (no report) to 5 (maximum detail). The option -qopt-report-phase (/Qopt-report-phase on Windows) controls report generation from various compiler phases, but it is recommended to use the default setting where the report is generated for all compiler phases. The report is a useful tool to gain insight into the performance optimizations performed, or not performed, by the compiler, and also to understand the interactions between multiple optimizations such as inlining, OpenMP* parallelization, loop optimizations (such as loop distribution or loop unrolling) and vectorization. The report is based on static compiler analysis. Hence the reports are most useful when correlated with dynamic performance analysis tools, such as Intel® VTune™ Amplifier or Vectorization Advisor (part of Intel® Advisor XE), that do hotspot analysis and provide other dynamic information. Once this information is available, the optimization information can be studied for hotspots (functions/loopnests) in compiler reports. It is important to note that the compiler can generate multiple versions of loop-nests, so it is useful to correlate the analysis with the version actually executed at runtime. The phase ordering of the compiler loop optimizations is intended to enable optimal vectorization. Often, understanding the loop optimiza-

tion parameters helps to further tune performance. In many cases, finer control of these loop optimizations is available via pragmas, directives, and options.

If the application contains OpenMP pragmas or directives, it can be compiled with `-qopenmp` (`/Qopenmp` on Windows) to enable full OpenMP based multi-threading and vectorization. Alternatively, the SIMD vectorization features of OpenMP alone can be enabled by using the option `-qopenmp-simd` (`/Qopenmp-simd` on Windows).

For doing studies where compiler-based vectorization has to be turned off completely, use the options `-no-vec -no-simd -qno-openmp-simd` (`/Qvec- /Qsimd- /Qopenmp-simd-` on Windows).

Data alignment plays an important role in improving the efficiency of vectorization. This usually involves two distinct steps from the user or application:

- Align the data.

When compiling a Fortran program, it is possible to use the option `-align array64byte` (`/align:array64byte` on Windows) to align the start of most arrays at a memory address that is divisible by 64. For C/C++ programs, data allocation can be done using routines such as `_mm_malloc(..., 64)` to align the return-value pointer at 64 bytes. For more information on data alignment, see <https://software.intel.com/en-us/articles/data-alignment-to-assist-vectorization>.

- Convey the alignment information to the compiler using appropriate clauses, pragmas, and directives.

Compiler-based software data prefetching can be enabled with the options `-O3 -xcore-avx512 -qopt-prefetch[=n]` (`-O3 /QxCORE-AVX512 /Qopt-prefetch[=n]` on Windows), for `n=0` (no prefetching) to 5 (maximal prefetching). Using a value of `n=5` enables aggressive compiler prefetching, disregarding any hardware prefetching, for strided loads/stores and indexed loads/stores which appear inside loops. Using a value of `n=2` reduces the amount of compiler prefetching and restricts it only to direct memory accesses where the compiler heuristics determine that the hardware prefetcher may not be able to handle well. It is recommended to try values of `n=2` to 5 to determine the best prefetching strategy for a particular application. It is also possible to use the `-qopt-prefetch-distance=n1[,n2]` (`/Qopt-prefetch-distance=n1[,n2]` on Windows) option to fine-tune application performance.

- Useful values to try for `n1`: 0,4,8,16,32,64.
- Useful values to try for `n2`: 0,1,2,4,8.

Loop-nests that have a relatively low trip-count value at runtime in hotspots can sometimes lead to sub-optimal AVX-512 performance unless the trip-count is conveyed to the compiler. In many such cases, the compiler will be able to generate better code and deliver better performance if values of loop trip-counts, loop-strides, and array extents (such as for Fortran multi-dimensional arrays) are all known to the compiler. If that is not possible, it may be useful to add appropriate `loop_count` pragmas to such loops.

Interprocedural optimization (IPO) is enabled using the option `-ipo` (`/Qipo` on Windows). This option can be enabled on all the source-files of the application or it can be applied selectively to the source files containing the application hot-spots. IPO permits inlining and other inter-procedural optimizations to happen across these multiple source files. In some cases, this option can significantly increase compile time and code size. Using the option `-inline-factor=n` (`/Qinline-factor:n` on Windows) controls the amount of inlining done by the compiler. The default value of `n` is 100, indicating 100%, or a scale factor of 1. For example, if a value of 200 is specified, all inlining options that define upper limits are multiplied by a factor of 2, thus enabling more inlining than the default.

Profile-guided optimizations (PGO) are enabled using the options `-prof-gen` and `-prof-use` (`/Qprof-gen` and `/Qprof-use` on Windows). Typically, using PGO increases the effectiveness of using IPO.

The option `-fp-model name` (`/fp:name` on Windows) controls tradeoffs between performance, accuracy and reproducibility of floating-point results at a high level. The default value for `name` is `fast=1`. Changing it to `fast=2` enables more aggressive optimizations at a slight cost in accuracy or reproducibility. Using the value `precise` for `name` disallows optimizations that might produce slight variations in floating-point results. When `name` is `double`, `extended` or `source`, intermediate results are computed in the corresponding precision. In most situations where enhanced floating-point consistency and reproducibility are needed `-fp-model precise -fp-model source` (`/fp:precise /fp:source` on Windows) are recommended.

The option `-fimf-precision=name` (`/Qimf-precision=name` on Windows) is used to set the accuracy for math library functions. The default is OFF, which means that the compiler uses its own default heuristics. Possible values of name are high, medium, and low. Reduced precision might lead to increased performance and vice versa, particularly for vectorized code. The options `-[no-]prec-div` and `-[no-]prec-sqrt` improve[reduce] precision of floating-point divides and square root computations. This may slightly degrade [improve] performance. For more details on floating-point options, see <https://software.intel.com/en-us/articles/consistency-of-floating-point-results-using-the-intel-compiler>.

The option `-[no-]ansi-alias` (`/Qansi-alias[-]` on Windows) enables [disables] ANSI and ISO C Standard aliasing rules. By default, this option is enabled on Linux, but disabled on Windows. On Windows, especially for C++ programs, adding `/Qansi-alias` to the compilation options enable the compiler to perform additional optimizations, particularly taking advantage of the type-based disambiguation rules of the ANSI Standard, which says for example, that pointer and float variables do not overlap.

If the optimization report specifies that compiler optimizations may have been disabled to reduce compile-time, use the option `-qoverride-limits` to override such disabling in the compiler and ensure optimization is applied. This can sometimes be important for applications, especially ones with functions that have big bodies. Note that using this additional option may increase compile time and compiler memory usage significantly in some cases.

The list below shows a sampling of loop-level controls available for fine-tuning optimizations - including a way to turn off a particular transformation reported by the compiler.

- `#pragma simd reduction(+:sum)`
The loop is transformed as is, no other loop-optimizations will change the simd-loop.
- `#pragma loop_count min(220) avg (300) max (380)`
Fortran syntax: `!dir$ loop count(16)`
- `#pragma vector aligned nontemporal`
- `#pragma novector //` to suppress vectorization
- `#pragma unroll(4)`
- `#pragma unroll(0) //` to suppress loop unrolling
- `#pragma unroll_and_jam(2) //` before an outer loop
- `#pragma nofusion`
- `#pragma distribute_point`
If placed as the first statement right after the for-loop, distribution will be suppressed for that loop.
Fortran syntax: `!dir$ distribute point`
- `#pragma prefetch *: <hint>: <distance>`
Apply uniform prefetch distance for all arrays in a loop.
- `#pragma prefetch <var>: <hint>: <distance>`
Fine-grained control for each array
- `#pragma noprefetch [<var>]`
Turns off prefetching [for a particular array]
- `#pragma forceinline (recursive)`

If placed before a call, this is a hint to the compiler to recursively inline the entire call-chain.

Optimization Notice

Intel's compilers may or may not optimize to the same degree for non-Intel microprocessors for optimizations that are not unique to Intel microprocessors. These optimizations include SSE2, SSE3, and SSSE3 instruction sets and other optimizations. Intel does not guarantee the availability, functionality, or effectiveness of any optimization on microprocessors not manufactured by Intel. Microprocessor-dependent optimizations in this product are intended for use with Intel microprocessors. Certain optimizations not specific to Intel microarchitecture are reserved for Intel microprocessors. Please refer to the applicable product User and Reference Guides for more information regarding the specific instruction sets covered by this notice.

Notice revision #20110804

CHAPTER 19

INTEL® ADVANCED VECTOR EXTENSIONS 512 - FP16 INSTRUCTION SET FOR INTEL® XEON® PROCESSORS

19.1 INTRODUCTION

The Intel® AVX-512 FP16 instruction set architecture supports a wide range of general purpose numeric operations for 16-bit half-precision IEEE-754 floating-point and complements the existing 32-bit and 64-bit floating-point instructions already available in Intel Xeon processors. This instruction set architecture also provides complex-valued native hardware support.

This instruction set architecture is ideal for numeric operations where reduced precision can be used, such as signal and media processing. For example, wireless signal processing operations such as beamforming, precoding, and minimum mean squared error (MMSE) perform well with this ISA. Furthermore, traditional signal processing such as real or complex-valued fast Fourier transform (FFTs) also works well with this instruction set. The advantage of using reduced precision in these cases is that because fewer bits are processed for each element, the overall compute throughput can be increased, allowing precision and speed to be traded against each other.

19.1.1 Terminology

Table 19-1 provides definitions of terminology used throughout this chapter.

Table 19-1. Terminology

Term	Description
CFP16	Complex-valued floating-point format comprising two FP16 values representing the real and imaginary values respectively. When used in SIMD, the individual real/imaginary values from each complex value are interleaved in the register.
Denormal	A subset of denormalized numbers that fill the underflow gap around zero in floating-point arithmetic.
FP16	Half precision 16-bit floating-point data format.
FP32	Single precision 32-bit floating-point data format.
FP64	Double precision 64-bit floating-point data format.
FFT	Fast Fourier Transform.
IEEE 754-2019	The current IEEE Standard for Floating-Point Arithmetic used in Intel® AVX-512 FP16 instructions.
Intel® AVX	Intel® Advanced Vector Extensions.
Intel® AVX2	Intel® Advanced Vector Extensions 2.
Intel® AVX-512	Intel® Advanced Vector Extensions 512.
Intel® AVX-512 FP16	ISA for handling half precision floating-point, added as an extension to Intel AVX-512.
Intrinsic	A function that can be called from a high-level language, like C/C++, which gives direct access to the underlying ISA. Intrinsics allow the programmer to bypass the compiler and directly specify that a particular instruction be used.
ISA	Instruction Set Architecture.

Table 19-1. Terminology (Contd.)

Term	Description
MMSE	Minimum Mean Squared Error.
NaN	Not A Number. A way to represent a value that is undefined or unrepresentable. For example, the square root of a negative number would generate a NaN value.
Normal	A floating-point number that can be represented without leading zeros in its significand.
SIMD	Single instruction, multiple data. A way of packing several data elements into a single container and operating on them all at once.
SINR	Signal-to-Interference-plus-Noise Ratio.
SSE	SIMD Streaming Extensions.

19.2 OVERVIEW

In this chapter, we describe the addition of the FP16 ISA for Intel AVX-512 into the Intel Xeon processor family to handle IEEE 754-2019 compliant half-precision floating-point operations (also known officially as binary16, or unofficially as FP16). This instruction set is general-purpose and can be used for all numeric operations that could be reasonably expected, including numeric operations (add, subtract, divide, multiply), fused operations (for example, fused multiply-add), comparisons, conversions to and from other data types, and many more. Broadly, the FP16 instruction set mirrors the floating-point support that is already available in Intel Xeon processors for 32-bit (FP32) and 64-bit (FP64), although there are a few exceptions to this, which will be noted where appropriate. There is one notable new feature of FP16 when compared to existing FP32 and FP64 instruction sets: the addition of native complex-value support for interleaved FP16 data, which is useful in scientific computing and signal processing.

The two major advantages of using the FP16 instruction set compared to other floating-point formats are increased execution throughput and reduced storage requirements. Half-precision floating-point values only require 16 bits for storing each value, as opposed to the 32 or 64 bits needed for other common IEEE floating-point formats. This allows FP16 to handle twice as many operations per each clock cycle compared to FP32, and four times as many compared to FP64. Similarly, the reduced size means that more values can be stored in a given memory region compared to the other formats, increasing the effectiveness of the registers and the cache hierarchy. The disadvantages are the reduced range and precision. It is the responsibility of the programmer to decide whether this floating-point format is suitable for a certain application.

Half-precision floating-point is useful for building systems where the dynamic range of floating-point is required but a lower numeric precision can be easily tolerated and traded for higher compute performance. Typical applications for half-precision floating-point include signal processing, media or video processing, artificial intelligence, and machine learning.

Historically, some limited support for half-precision data types was available in processors from the 3rd generation Intel® Core™ processor onwards, but the operations were restricted to converting between half-precision and FP32 values. On older platforms, all numeric operations had to be implemented using higher precision formats and down-converted on completion. Those instructions were useful for compatibility with other platforms (for example, Intel® GPUs), but did not realize the benefits in higher compute performance brought about in FP16.

IEEE FP16 is not the only 16-bit floating-point format. Another common type is bfloat16, which is primarily used in artificial intelligence and machine learning. Intel Xeon processors support some bfloat16 operations, including type conversions and a few limited numeric operations, but not the full range of general-purpose operations that are supported in FP16 for Intel AVX-512. This chapter describes only the instruction set relating to IEEE 754-2019.

This chapter covers both the general-purpose instruction set as well as the new complex-valued instructions. We then look at the numeric implications of using FP16 and discuss how to write optimal code sequences for some common operations.

The examples provided in this document use the intrinsic and data type support provided as part of the Intel® OneAPI DPC++ Compiler.

19.3 FP16 NUMERIC INSTRUCTIONS

FP16 is an instruction set extension that mirrors the existing support for other floating-point operations in Intel AVX-512 and makes it available in IEEE-754 FP16 (binary16) number format. It is a general-purpose instruction set, and features instructions that support all common operations that are required in typical numeric software applications. Briefly, the following classes of instructions are supported:

- Fundamental IEEE numeric: Addition, subtraction, multiplication, division, and square root.
- Fused: Fused (multiply-accumulate) operations covering `fmadd`, `fmsub`, `negated fma`, `fmaddsub`, and `fmsubadd`.
- Comparison: Minimum, maximum, and compare-to-mask (e.g., `neq`, `lt`, `gt`, etc.).
- Conversions: Conversions to and from other common data types, including 16/32/64-bit integer and FP32/FP64 floating-point.
- Approximation: Fast, but approximate operations to support reciprocal and reciprocal-square-root.
- Specialized: Significand (mantissa)/exponent manipulation, scaling, and rounded scaling.
- Complex: Native complex-value multiply and fused-multiply operations.

The following sections will provide information on how to use these new instructions, the impact on performance, and the consequences of the reduced floating-point decision.

19.3.1 Data Type Support

Table 19-2 shows the new data types supported with the FP16 instruction set. In each case, the name of the equivalent type in C or C++ is provided.

Table 19-2. Supported FP16 Data Types

Type Format	C/C++ Type Name	Notes
Scalar	<code>_Float16</code>	Single 16-bit value stored in IEEE FP16 format
128-bit AVX register	<code>__m128h</code>	8 x FP16 values, or 4 x complex FP16 values (CFP16)
256-bit AVX2 register	<code>__m256h</code>	16 x FP16 values, or 8 x complex FP16 values (CFP16)
512-bit AVX-512 register	<code>__m512h</code>	32 x FP16 values, or 16 x complex FP16 values (CFP16)

The complex instructions operate on standard SIMD vector types, such as `__m128h`, but internally those instructions treat the register as sets of complex-valued pairs, as shown in Figure 19-1. Note that we shall refer to a complex pair of FP16 values as ``CFP16'`. The CFP16 type is laid out as though it were an array of two FP16 values, or a C++ type such as `std::complex<_Float16>`.

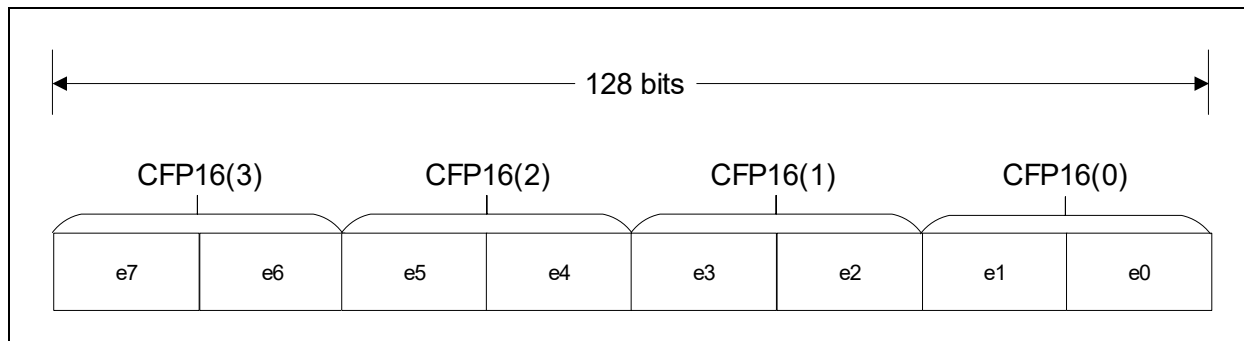

Figure 19-1. Layout of a 128-Bit Register Representing Four Complex FP16 (CFP16) Values

In the latest Intel OneAPI compilers, 16-bit floating-point literals can be created by suffixing a value with `f16`. For example:

```
_Float16 value = 12.34f16;
```

19.3.2 Overview of Intrinsics

In common with the intrinsics for other vector instruction sets, FP16 intrinsics take the following form:

```
result = _mmBITLENGTH_OPNAME_ELEMENTTYPE(arguments)
```

The bit-length can be 512, 256, or 128 bits, and in the 128-bits case the `BITLENGTH` field is empty. The `OPNAME` is a short descriptor or abbreviation of what the operation does (for example, `add`, `sub`, `fmadd`). The element type is `sh` for FP16 scalar (scalar-half), `ph` for a vector of FP16 values (packed-half), or `pch` for a vector of CFP16 values (packed-complex-half). Table 19-3 gives some examples to illustrate the naming conventions.

Table 19-3. Example Intrinsic Names

Intrinsic Name	Description
<code>_mm_sub_sh</code>	Subtract a single scalar FP16 element from another scalar FP16 element.
<code>_mm_add_ph</code>	Add a pair of 8xFP16 vector registers to form a result containing 8xFP16 outputs.
<code>_mm256_add_ph</code>	Add a pair of 16xFP16 vector registers to form a result containing 16xFP16 outputs.
<code>_mm512_add_ph</code>	Add a pair of 32xFP16 vector registers to form a result containing 32xFP16 outputs.
<code>_mm256_fmadd_ph</code>	Multiply a pair of 16xFP16 vector registers and add the result to a third vector register of 16xFP16 values, forming a result containing 16xFP16 vector elements.
<code>_mm512_rcp_ph</code>	Compute the reciprocal of a vector register containing 32xFP16 values, generating an output of another vector register containing 32xFP16 values.
<code>_mm256_fmadd_pch</code>	Compute the complex multiplication of 8xCFP16 (complex-FP16) values, adding the result to another such register, and generating a result containing 8xCFP16 elements.
<code>_mm512_conj_pch</code>	Compute the conjugate of a 512-bit register containing 16xCFP16 (complex-FP16) elements.

Note that `pch` complex operation intrinsics are only provided for multiply and fused-multiply-add operations since these require special hardware support. No intrinsics are provided for operations like addition, since the existing `add_ph` intrinsic behaves correctly for those without extra support requirements.

For a complete list of all the intrinsics provided as part of FP16, refer to the Intel® Intrinsic Guide.

In the remainder of this chapter where the names of intrinsics are given, typically only the 128-bit variant is shown. Because AVX-512-FP16 supports VL encoding, all three length variants of the intrinsics are available (i.e., 128-bit, 256-bit, 512-bit).

19.3.3 Fundamental Complex-Valued Support

For complex-valued operations the primary place where hardware support is provided is in multiplication. Complex multiplication requires several steps, and the FP16 ISA accelerates those steps. Simpler operations, such as addition and subtraction, do not require explicit complex support since these can be handled using the other FP16 instructions (for example, addition of two complex numbers is just the addition of respective real and imaginary values from the two inputs, so `_mm_add_ph` can be directly used). Note that complex division is not supported in hardware as this is an uncommon operation, and it can be constructed from the hardware multiplier and complex multiplier support if required.

To illustrate the mechanics of how complex multiplication is supported, consider the following complex multiply:

$$(a + bi) * (c + di)$$

This operation can be refactored as follows:

$$(ac - bd) + (ad + bc)i$$

Note that to compute each of the real and imaginary components of the multiply a stand-alone multiply is used first, followed by a suitable `fmadd/fmsub` instruction. The hardware support for complex-valued multiplies uses these partial `mul/fmadd` instructions in sequence to perform the entire complex multiply. The hardware can schedule and route the data inside the processor to do this more quickly and efficiently than using an explicit instruction sequence to move the real and imaginary data into the correct places. Note however that each intermediate step produces a temporary FP16 answer, so the final result will have had an FP16 quantization step.

Using the symbols from the example above, a complex-fma (that is, accumulating against another complex number) can be implemented using the following refactoring:

$$((\text{accReal} + ac) - bd) + ((\text{accImag} + ad) + bc)i$$

This sequence is equivalent to two FMA operations being performed for each of the real/imag components.

The conjugate of a complex number is formed by negating its imaginary component. A common operation with conjugation is to multiply a complex number with a conjugate of another complex number. Conjugation in FP16 is supported using three classes of intrinsic, as illustrated in Table 19-4.

Table 19-4. Conjugation Instructions

Intrinsic Name	Description
<code>_mm_conj_pch</code>	Compute the conjugate of a register containing CFP16 (complex-FP16) elements by negating each imaginary value.
<code>_mm_fcmul_pch</code>	Compute the multiplication of a conjugated value with another complex value.
<code>_mm_fcmadd_pch</code>	Compute the multiplication of a conjugated value with another complex value, adding the result to a third complex-vector register.

Both the multiply and the FMA are able to perform the conjugation as part of the instruction operation itself. It is not necessary to conjugate the value first. For example, an `_mm_fcmul_pch` intrinsic is functionally equivalent to:

```
_mm_fcmul_pch(_mm_conj_pch(lhs), rhs)
```

However, `_mm_fmulp_c` will operate in fewer cycles than calling that sequence explicitly. When the compiler notices separate conjugate and multiply intrinsics being used, it fuses them into a single conjugate-multiply.

19.3.4 Using Intel® AVX-512 Bit Masks for Real-Valued Operations

FP16 is able to use the bit-mask features of Intel AVX-512 both to control when operations in a vector register take place, and to generate masks that store the results of performing tests on vector registers.

Masks allow execution of an instruction to be conditionally applied to selected elements of a vector register. Most instructions permit such a mask register to be supplied as part of the operation, where each bit within the mask corresponds to a different element of the vector register. If a given mask bit is set, then the instruction operates on the corresponding element. If the bit is cleared, the operation is not performed and that element's output is replaced by another value. The cleared output value can either be taken from another source register, or it can be zeroed. The operation of a masked instruction is illustrated in Figure 2. Note that the operation only takes place where the 8-element mask has a corresponding bit set and all other outputs are zeroed.

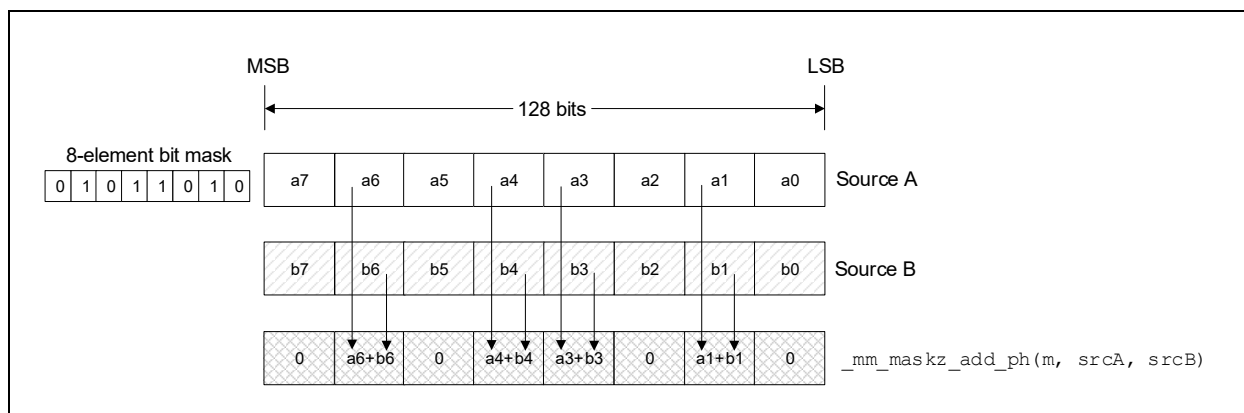

Figure 19-2. Illustration of a Zero-Masked FP16 Add On Two 128-Bit Vectors

Note that masks also control whether faults within an instruction are suppressed. If an operation generates a fault in a particular element, but the element's operation has been disabled by a zero bit in the mask, then the fault is not reported.

Some instructions in Intel AVX-512 can generate mask registers, and with FP16, these are normally the result of a comparison operation. For example, consider the following code snippet:

```
whichElementsAreLess = _mm512_cmp_ph_mask(lhs, rhs, _CMP_LT_OS);
```

In this example, every element of the left-hand vector is compared to see if it is less than the corresponding element in the right-hand vector. If the left element is less than the right element, then a 1 is generated in the mask bit output, otherwise a zero is emitted. This comparison instruction allows all the major binary comparison operations to be performed between two vectors.

The FP16 instruction set also provides support to test for special values using the `_mm_fpclass_ph_mask` instruction. This instruction takes a special immediate value that directs the instruction to the numeric classes to look for in the vector register (for example, infinities, NaN, zero, denormal). This instruction is often used in combination with other instructions to remove special case values from a register and replace them with something different. For example, the following code snippet removes NaN values and replaces them with zero:

```
_mmask8 whichAreNan = _mm_fpclass_ph_mask(values, QUIET_NAN | SIGNAL_NAN);
__m128h valuesWithNoNan = _mm_mask_blend_ph(whichAreNan, values, __m128h());
```

In Intel AVX-512, there is a special instruction that does direct replacement of special values with known constants called `_mm_fixupimm_ps/pd`, but this is not available in the FP16 instruction set.

19.3.5 Using Intel® AVX-512 Bit Masks for Complex-Valued Operations

When a mask operation is applied to an intrinsic that operates directly on complex instruction data (for example, `_mm512_mask_fmadd_pch`), then each mask bit refers to a complex pair of FP16 values, not to the individual FP16 values. This is illustrated in Figure 19-3. Note that there are eight FP16 elements, grouped into four CFP16 complex values. The four mask bits correspond to the four CFP16 values.

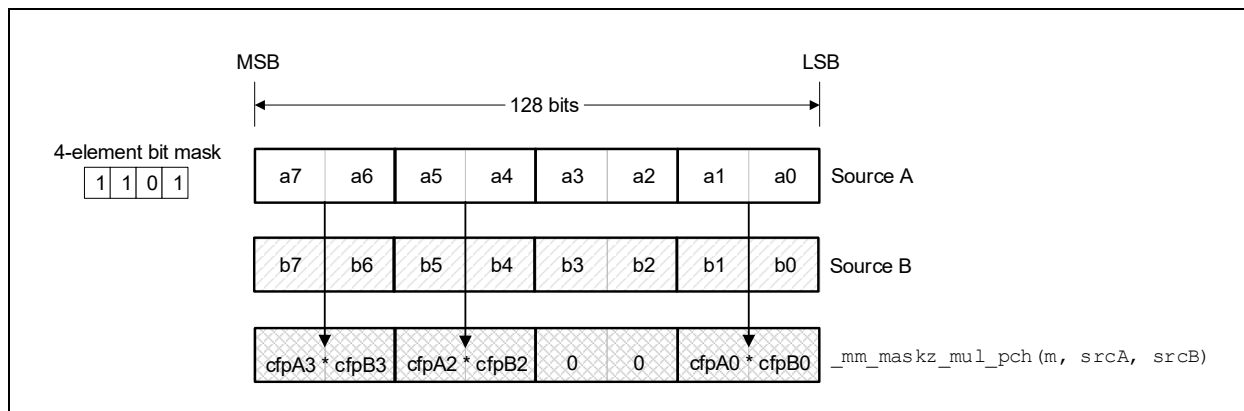

Figure 19-3. Illustration of a Masked Complex Multiplication

No direct numeric support is provided for complex operations such as addition, subtraction, and real-valued scaling, but their standard real-valued equivalent instructions can be used instead. However, if such an operation has to be masked on a per-complex-element basis, then the incoming complex-valued mask needs to be expanded into pairs of identical bits, one pair per complex-element. An example of this is illustrated in Figure 19-4. Note that the incoming mask bit, which is per CFP16 element, needs to be expanded to duplicate each bit for the real-valued intrinsic.

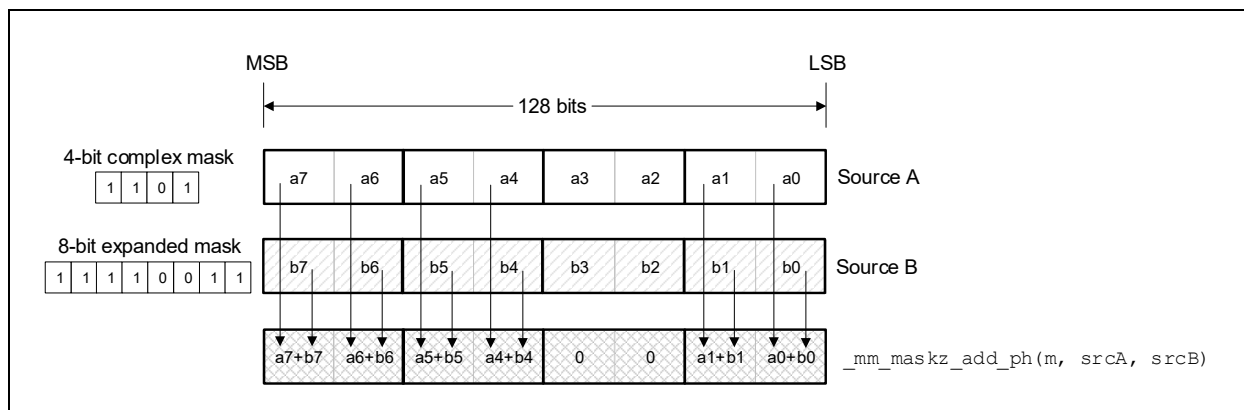

Figure 19-4. Illustration of Using a Real-Valued FP16 Vector Operation for Implementing a Masked Complex Addition

The operation to expand the incoming complex-mask-bits to generate real-valued mask could be performed in numerous different ways, but one efficient way to achieve this operation is shown in Example 19-1. This code fragment uses the fast mask-to-vector and vector-to-mask instructions to effect the upscaling of the bit-mask elements.

Example 19-1. Function for Converting from a Complex-Valued Mask To a Real-Valued Mask by Duplicating Adjacent Bits

```

__mmask8 getRealMaskFromComplexMask(__mmask8 m)
{
    // 4 incoming bits representing the 4 complex elements in a 128-bit register.
    // Each mask bit is converted into an entire element in a vector register
    // where a 0-mask generates 32x0, and a 1-mask generates 32x1. For example
    // 0010 -> [000....00], [000...000], [111....111], [000....000]
    auto wholeElements = _mm_movm_epi32(m);

    // Each complex element can now be treated as a pair of 16-bit elements instead,
    // and the MSB of each 16-bit unit can be extracted as a mask bit in its own right.
    return _mm_movepi16_mask(wholeElements);
}
    
```

It may also be necessary to perform a similar operation in reverse, where pairs of bits representing adjacent FP16 values need to be reduced in some way into a single bit representing the complete complex element (e.g., AND, OR). For example, if two complex vectors must be compared for equality then the individual FP16 elements must be compared for equality first, and then if two adjacent mask bits are both set (that is, the logical AND of those bits), then the complex element as a whole must be equal. This comparison test is illustrated in Figure 19-5. Note that some of the sub-elements in each CFP16 do compare equal when using the `_mm_cmp_ph_mask` intrinsic, but both elements in each CFP16 value must be equal for the complex values to be truly equal to each other.

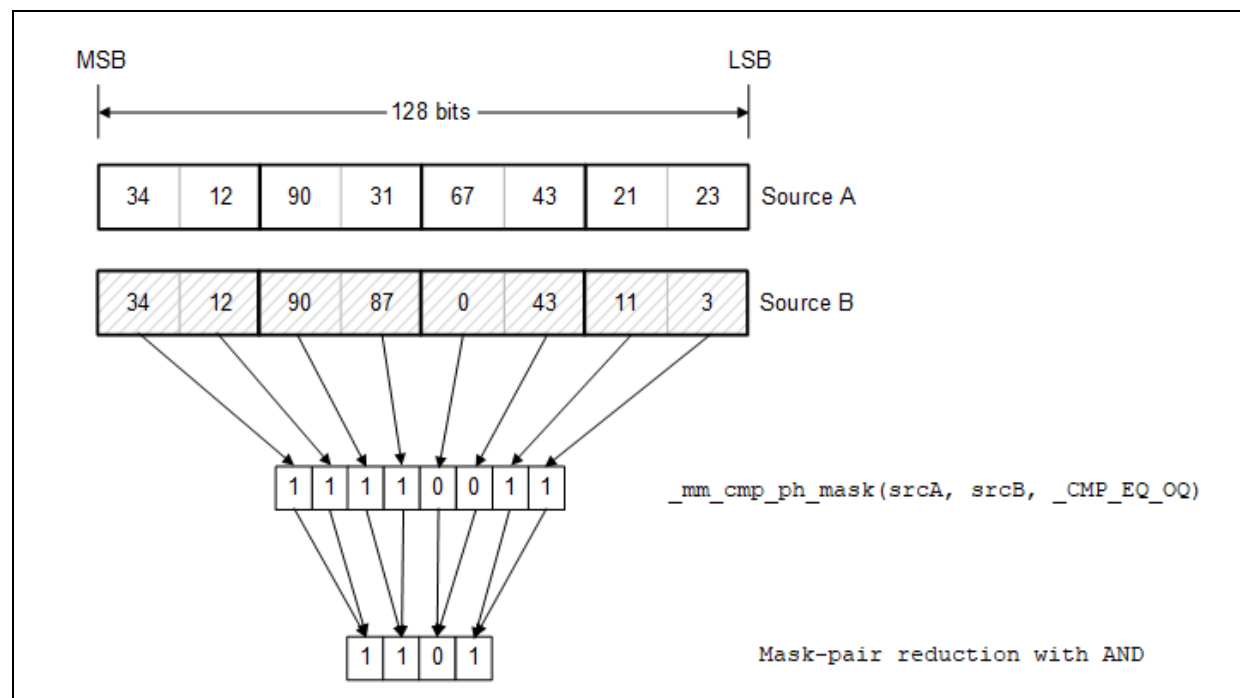

Figure 19-5. Comparison Operation Between Two Complex-Valued Vectors.

The mask bits are generated using a real-valued comparison, then adjacent bits combined using AND

One implementation of the function to combine adjacent mask bits using an AND operation is shown in Example 19-2. Like the example above, it uses the mask-to-vector and vector-to-mask instructions to good effect.

Example 19-2. Function for Converting from a Real-Valued Mask to a Complex-Valued Mask By AND-Combining Adjacent Bits

```
__mmask8 getComplexMaskFromRealMask_AND(__mmask8 m)
{
    // 8 incoming bits representing the 8 real-valued elements in a 128-bit register.
    // Broadcast the bits into 8-bit elements of all 1's or all 0's.
    auto wholeElements = _mm_movm_epi8(m);

    // Generate an entire vector of 1's (typically a ternlogic will be used, which is
    // very cheap and can be done in parallel with the movm above, or hoisted when
    // used repeatedly.
    const auto allOnes = _mm_set1_epi16(-1);

    // Extract single mask bits from each 16-bit element which are the logical ANDs of the
    // MSBs of each incoming 8-bit element. Because the movm above generated all 0/1 bits
    // across the whole element the only combinations of values in each 32-bit unit are
    // both all zero, both all one, or one of each. The logical AND of the MSBs can only
    // occur when both 8-bit sub-elements are all ones, so this is equivalent to
    // comparing the 16-bit block as though it were entirely 1, which is a direct
    // equality comparison.
    return _mm_cmp_epi16_mask(wholeElements, allOnes, _MM_CMPINT_EQ);
}
```

Note that the individual mask bits are expanded to 8-bit elements and then compared for equality as 16-bit elements to combine adjacent elements. There is no need to expand to the same size as the data being processed (that is, 16/32-bit respectively in this case), since the bitwise pairing is independent of the original data element sizes. By using smaller registers, efficiency is very slightly improved compared to using wider registers.

The adjacent mask bits could also be combined using an OR operation, which might be useful if testing whether a complex value is NaN (that is, a complex value is NaN if either of its individual elements is NaN). A sequence for determining an OR of adjacent mask bits is shown in Example 19-3.

Example 19-3. Function for Converting from a Real-Valued Mask To a Complex-Valued Mask By OR-Combining Adjacent Bits

```
__mmask8 getComplexMaskFromRealMask_OR(__mmask8 m)
{
    auto wholeElements = _mm_movm_epi16(m);

    // Similar logic to the AND variant above but now any 32-bit element which
    // isn't zero represents the logical OR of two adjacent 16-bit block
    // elements in one 32-bit block.
    return _mm_cmp_epi32_mask(wholeElements, _m128i(), _MM_CMPINT_NE);
}
```

19.4 NUMERICS

Using FP16 instead of the more conventional and widely used FP32 and FP64 formats introduces a number of interesting numeric behaviors. It is beyond the scope of this chapter to discuss these fully or

to describe the numeric methods required to build FP16 algorithms, but in this section, we highlight a few of the properties and behaviors of the FP16 number format and the consequences that arise from this.

19.4.1 Introduction to FP16 Number Format

An FP16 floating-point number is represented using 16 bits, which are laid out as shown in Figure 19-6. The figure also shows two other floating-point number formats for comparison, one being the common 32-bit FP32 format, and the other being the alternative 16-bit floating-point format called brain-float 16, which is used for machine learning. Note how bfloat16 is simply the upper 16-bits of the FP32 format, giving it the same dynamic range as FP32 but with considerably reduced precision, making this ideal for machine-learning applications. In contrast, the IEEE FP16 format modifies the sizes of the significand and the exponent to produce a more balanced blend of precision and range, which is more suitable for general purpose algorithms.

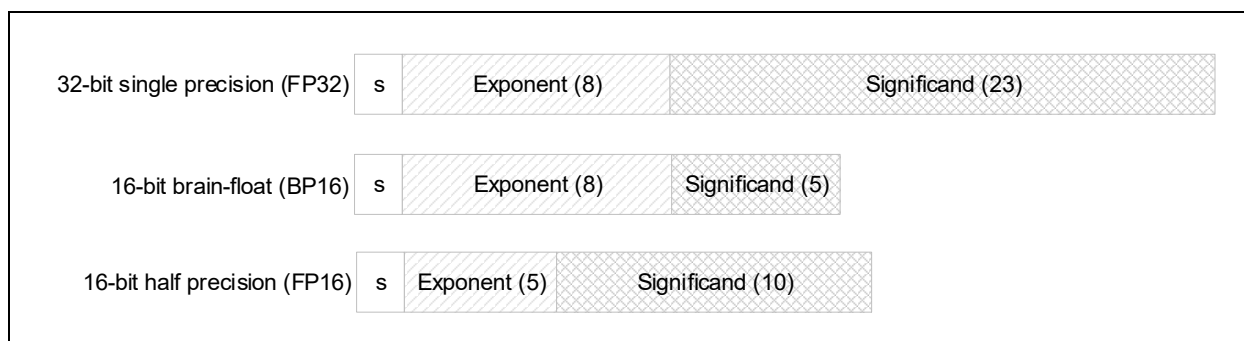

Figure 19-6. Bit Layout of Three Types of Floating-Point Formats

Certain bitwise operations can be used to manipulate the floating-point numbers without requiring special hardware support. For example, an absolute operation (that is, convert the value to its positive equivalent) can be implemented as a bitwise AND of the lower 15 bits of the value, thereby stripping off any sign bits. Similarly, functions like negate, negative-absolute (nabs), copy-sign, test-sign, and so on can also be implemented using existing Intel AVX-512 bitwise intrinsics.

19.4.2 Observations on Representing Numbers in FP16 Format

Although FP16 behaves functionally the same way as FP32 and FP64, the limited number of bits in its representations means that some limits are imposed on the permitted values. In FP32 and FP64, most of the useful human-comprehensible numbers can be easily represented without considering too much about the limitations in value representation imposed by the floating-point format, but those limitations show up in FP16 limitations more easily. In Figure 19-7 some landmark values on the real-valued positive number line are illustrated, and in Table 19-5 further useful numbers are listed.

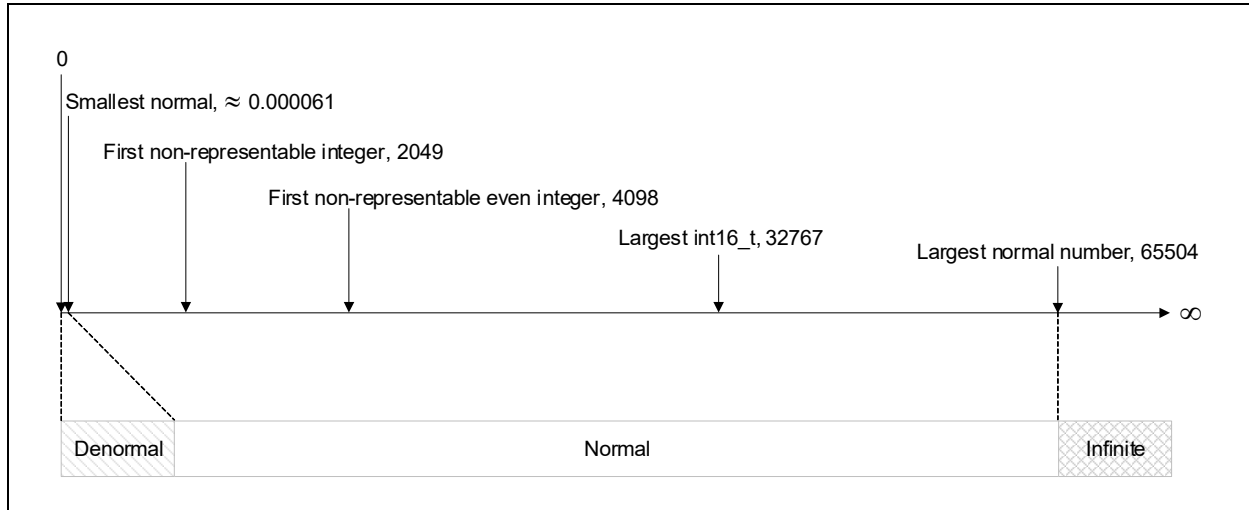

Figure 19-7. Landmark Numbers on the Real-Valued FP16 Axis

Table 19-5. Useful or Interesting FP16 Numbers

Value	Hex Representation	Description
0	0x0000	Zero
0.000000059604645	0x0001	Smallest denormal value
0.000060975552	0x03ff	Largest denormal value
0.00006103515625	0x0400	Smallest normal value
1	0x3c00	One
Inf	0x7c00	Positive Infinity
-Inf	0xfc00	Negative Infinity

Some consequences of using the FP16 number format include:

- Denormal numbers are not very small; it is easy to generate a number that gets too small to be represented using an FP16 normal value.
- Infinity starts very low down; it is only slightly less than the maximum value of an unsigned 16-bit integer. Overflow of values converted from 16-bit integers can quickly lead to infinities.
- Only integers up to a magnitude of 2048 can be fully represented. Beyond that, the permitted integers become very sparse very quickly. Rounding from a real integer type to an FP16 value introduces large absolute integer errors if the integer is above 2048.

These limitations may seem cumbersome at first, but there are good reasons why FP16 representation is a good fit for many signal-processing applications. Firstly, it is important to consider the Signal-to-Interference-plus-Noise ratio, or SINR. In a typical signal-processing system, such as a wireless receiver, the signals of interest are almost always subject to measurement noise. In the case of a wireless system, this noise would be introduced by receiver thermal-noise or in-band interference.

With FP16 number representation, any value on the real number-line within the normal range is subject to approximately -73.7 dB of quantization noise when quantized to FP16 format¹. To use common signal-processing parlance, the SINR is always ~ 73.7 dB, meaning that the quantizing error variance is $10^{-7.37}$

times the squared-magnitude of the signal. When compared to a typical received SINR of 25 dB, this means that the variance of the additional error introduced by the FP16 quantization is $10^{48.7/10}$, $\sim 74,131$ times lower than the measurement noise of the signal. In effect, it adds a negligible extra noise power.

Other signal processing requirements include dynamic range. The FP16 representation is able to maintain the 73.7 dB SINR over the complete dynamic range of a perfect 16-bit ADC. Care must be taken to exploit the floating-point aspect of FP16 and not directly convert integers to FP16, as squaring operations will likely result in "Inf". However, this is easily overcome by converting 16-bit integers to FP16 and then scaling by a fixed constant: 1/256 is a good choice.

19.4.3 Numeric Accuracy Guarantees

In any floating-point calculation it is impossible to give the result of every possible computation because not every value has a valid representation. The output has to be quantized to a nearby value which can be represented in that number format. If the result is not representable, the distance between the next lowest representable value and the next highest representable value is called the unit-in-last-place, or ULP (and less commonly but equivalently, the unit-of-least-precision), and the actual answer will lie somewhere between the two. When the output value is rounded up or down to the nearest representable value, it therefore follows that the error in that calculation is no more than 0.5 ULP.

In IEEE 754 floating-point arithmetic, the standard mandates that the result of any hardware implementation will generate a correctly rounded result that has no more than 0.5 ULP of error when rounding 'to nearest' for the following operations:

- Addition
- Subtraction
- Multiplication
- Division
- Square root
- Fused multiply-add

When rounding up, down, or toward zero, the error is less than 1 ULP.

The fused multiply-add guarantees that the intermediate result of the multiplication is kept in a higher precision form internally before being added. This means that the result of an FMA operation can have less overall error than doing a sequence of individual multiply and add instructions.

The Intel AVX-512 FP16 instruction set is compliant with IEEE Standard 754-2019, and arithmetic operations on it are implemented in the spirit of the Standard (which does not require arithmetic operations for binary16). Consequently, all the operations listed above yield correctly rounded results. FP16 also contains a few instructions (not defined in IEEE 754-2019) that produce approximate results to within 0.5625 ULP error. These include:

- Reciprocal (rcp)
- Reciprocal square-root (rsqrt)

Further examination of these special cases is given in later sections.

Note also that complex multiplications (and fused multiplications) have an intermediate quantization to FP16 because, as described earlier, the hardware implements these operations as a sequence of FMAs. Each step of that sequence introduces quantizing, so the overall effect of the complete complex multiply has some small error.

1. IEEE TRANSACTIONS ON CIRCUITS AND SYSTEMS-II: EXPRESS BRIEFS, VOL. 63, NO. 6, JUNE 2016: Quantization Noise Power Estimation for Floating-Point DSP Circuits Gabriel Caffarena, Senior Member, IEEE, and Daniel Menard, Member, IEEE: <https://ieeexplore.ieee.org/document/7407669>.

19.4.4 Handling Denormal Values

FP16 differs from FP32 and FP64 floating-point by allowing computations involving denormals to be performed with no impact on cycle count. This is in contrast to FP32 and FP64 computation modes where handling denormals under some conditions can introduce cycle performance penalties. In FP32 and FP64 computations, when a denormal value is encountered the instruction might trap and call into a software routine to handle the computation instead, which increases the number of processor cycles required. Describing when this occurs and what the penalties would be is beyond the scope of this document. However, it is common to attempt to avoid denormal values in FP32 and FP64 computations where possible by modifying two FP execution flags:

- **DAZ.** Denormals Are Zero: Any denormal inputs are replaced by zero before use.
- **FTZ.** Flush To Zero: Any outputs that would be denormal are replaced by zero.

Since FP16 handles denormals at full speed, all FP16 computations ignore the DAZ and FTZ flags and modifying these flags has no impact on FP16 numeric behavior or performance.

19.4.5 Embedded Rounding

In common with other Intel AVX-512 instructions, the FP16 instruction set allows the use of an instruction attribute called Static Rounding Mode. Rather than depending upon the contents of a global control register (called MXCSR) to set the floating-point rounding mode, most of the Intel AVX-512 FP16 instructions can override the rounding mode behavior for only that instruction. Some permitted rounding modes are shown in Table 19-6.

For convenience, intrinsics are provided to give easy access to embedded rounding modes. For example, the FP16 addition instruction can have the rounding mode controlled by using the following intrinsic:

```
__m128h _mm512_add_round_ph (__m128h a, __m128h b, int rounding);
```

The third parameter, which supplies the rounding mode immediate, can be taken from the third column of Table 19-6, which describes four of the IEEE rounding modes and the required selector to invoke that behavior.

Table 19-6. Conjugation Instructions

IEEE 754-2019 Rounding Mode	Description	C Intrinsic Constant Selector
roundTiesToEven	Round toward nearest floating point, with ties to even.	<code>_MM_FROUND_TO_NEAREST_INT _MM_FROUND_NO_EXC</code>
roundTowardPositive	Round toward negative infinity.	<code>_MM_FROUND_TO_NEG_INF _MM_FROUND_NO_EXC</code>
roundTowardNegative	Round toward positive infinity.	<code>_MM_FROUND_TO_POS_INF _MM_FROUND_NO_EXC</code>
roundTowardZero	Round toward zero.	<code>_MM_FROUND_TO_ZERO _MM_FROUND_NO_EXC</code>

The following points should be noted:

- When a rounding mode is explicitly used then this implies that the 'suppress-all-exceptions' flag is also set for that instruction. Therefore, an instruction that uses embedded rounding never raises a floating-point exception.
- The C intrinsic constant selector name `_MM_FROUND_TO_NEAREST_INT` is not ideal, but that name has been historically used for so long in all common compilers that it is difficult to change to something more meaningful.
- Embedded rounding is only permitted on full width AVX-512 intrinsics (e.g., `_mm512_op_round_px`) or scalar operations (e.g., `_mm_op_round_sx`). It is not permitted on AVX-512 VL encoded 128-bit or 256-bit operations.

19.4.6 Legacy FP16 Data Type Conversion

Two older Intel instruction sets already supported FP16 values as a storage format and provided conversion instructions to and from other data types. For example:

- `_mm_cvtph_ps`: Convert from FP16 to FP32.
- `_mm_cvtps_ph`: Convert from FP32 to FP16.

These instructions were originally available in the FP16C ISA for 128-bit and 256-bit registers. The Intel AVX-512 FP16 ISA further extended these instructions to work with 512-bit registers, and also added the option to conditionally mask selected elements (for example, `_mm512_mask_cvtph_ps`).

These instructions do not have embedded broadcast modes. It is recommended that the newer conversion instructions described in the next section be used instead.

19.4.7 FP16 Conversions to and from Other Data Types

The Intel AVX-512 FP16 ISA contains a comprehensive set of instructions that convert to and from most of the other supported data types, with and without rounding.

Conversions from FP16 to other data types take the following intrinsic forms:

- `_mm_cvtph_epi16`: Convert from half-precision to 16-bit integer.
- `_mm_cvtph_epi64`: Convert from half-precision to 64-bit integer.
- `_mm_cvtxph_ps`: Convert from half-precision to FP32.

Note that an extra `x` appears in some of the intrinsics to differentiate the intrinsics from their older FP16C/Intel AVX-512 F ISA counterparts. Only instructions that could be confused with older instruction sets have an `x` in their name (for example, the `int16` conversion only appears in Intel AVX-512 FP16 so it does not need to be disambiguated).

When an FP16 denormal value is converted to a higher-precision FP32 or FP64 value, the denormal is converted to a normal representation in the output format.

Although the older conversion instructions perform type conversion as expected, they do not support embedded broadcasts. It is recommended to use the newer instructions wherever possible to get some instruction encoding advantages.

Conversions to FP16 format from other data types all take the intrinsic form shown in the following examples:

- `_mm_cvtepi16_ph`: Convert from 16-bit integer to half-precision.
- `_mm_cvtepi64_ph`: Convert from 64-bit integer to half-precision.
- `_mm_cvtxps_ph`: Convert from FP32 to half-precision.

Note that some care must be taken when converting from higher precision types into FP16. For example, conversion from a signed 16-bit integer value to FP16 generates the equivalent integers in FP16, albeit with some small loss possibly (for example, integer values greater than 2048 may be quantized to a nearby integer, not the exact integer). However, a more serious issue is that values that are converted from full-range 16-bit unsigned integer format are converted into FP16 values, which are at the very upper end of the permitted FP16 number range. Almost any numeric operation on such values could lead to overflow and the generation of infinities. In such scenarios, it is beneficial to perform some scaling on the value after conversion, to bring the range of the new values into the middle of the FP16 number range, thereby making it more difficult to hit infinities or denormals through normal compute operations.

Note that some care must be taken when converting to and from integer types to FP16. In particular, it must be noted that not all values in the 16-bit signed integer range of -32768 to +32767 can be represented in FP16. There will be some quantization effects with values above 2048. As discussed in Section 19.4.2, this additional quantizing noise power is negligible in most signal processing applications. However, the 16-bit integer range includes numbers that become close to Inf in FP16 format (values above 65504 are Inf). To avoid potential problems when performing typical signal-processing tasks such as cross-correlations, which operate in volts², 16-bit integer values should be scaled after conversion to FP16. A typical scale would be 1/256. In this scheme, 32768 would be converted to 128.00f16. Note that

both $128.00^2=16384.00$ and $(2/256)^2=0.00006103515625$ are within the normal range of FP16 values. This means that most typical signal-processing operations can be performed with values mostly in the normal range (with $(1/256)^2$ just falling outside of the normal range). So, by the simple expedient of applying a fixed scaling, FP16 representation can be used to comfortably span the dynamic-range presented by 16-bit ADCs and DACs.

19.4.8 Approximation Instructions and Their Uses

In common with Intel AVX-512, the new FP16 instructions support a number of approximation functions, including reciprocal (`rcp`), and reciprocal-sqrt (`rsqrt`). Although many instructions in Intel AVX-512 FP16 are accurate to within 0.5 ULP, as guaranteed by IEEE 754, the approximation instructions give very slightly less accurate results, but these are still useful, especially when compared with their equivalents in FP32 and FP64.

In FP32 and FP64 the approximation instructions are quite rough (that is, have a very high ULP error) and can only be used as a substitute for full-precision operations if combined with one or two Newton-Raphson iterations to refine the initial approximation to a point where it becomes sufficiently accurate. However, in FP16 the approximation functions give results that are so close to their full precision results - within 0.5 ULP for 98% of the possible values and within 0.5625 ULP for the remaining 2% of values - that there is no need to add Newton-Raphson iterations. This makes the approximation instructions very useful. They give virtually the correct answer, but with substantial benefits in performance over their full-accuracy counterparts. The following sections examine each approximation instruction in more detail.

19.4.8.1 Approximate Reciprocal

The reciprocal instruction in Intel AVX-512 FP16 behaves almost identically to the equivalent code sequence implemented using a division of the constant 1.0. For example, consider the following two code fragments:

```
__m512h trueRcp = _mm512_div_ph(_mm512_set1_ph(1.0f16), x); // #1
__m512h approxRcp = _mm512_rcp_ph(x); // #2
```

The first, true reciprocal-by-division is guaranteed to be within 0.5 ULP, assuming rounding to nearest-even is used, but it takes approximately 15 cycles in 128 or 256-bit mode, and 24 cycles in 512-bit mode. It has a throughput of one instruction every 8 cycles in 128 or 256-bit mode, or one every 16 cycles in 512-bit mode. In contrast, the approximate reciprocal instruction is within 0.5 ULP for 98% of the possible valid input values, and the remaining 2% of values are within 0.5625 ULP, but it has a latency of only 4 cycles (or 6 cycles in 512-bit mode), and a throughput of 1 cycle (or 1.5 cycles in 512-bit mode). This dramatic improvement in compute performance of `rcp_ph` for almost no difference in numeric performance makes it ideal whenever that particular use case is required. Only when there is an absolute requirement for IEEE floating-point behavior should the division sequence be used instead.

19.4.8.2 Approximate Division

The two code fragments below show how a division could be implemented:

```
__m512h trueDiv = _mm512_div_ph(lhs, rhs); // #1
__m512h approxRcp = _mm512_mul_ph(lhs, mm512_rcp_ph(rhs)); // #2
```

The first of these uses the actual division instruction and is accurate to within 0.5 ULP (that is, correctly rounded, regardless of rounding mode).

The second sequence implements division by multiplying by the reciprocal, where the reciprocal is computed using the approximate function. We have already seen in the section above that the reciprocal approximation is very good, and this means that performing division using this sequence also turns out to be very good for most FP16 values. To illustrate how good the approximation of the divide is, consider the heat-map shown in Figure 19-8. It shows how the ULP error changes for all the possible values of divisors and dividends. The green areas show that the approximation sequence gives identical results to a real division operation when the dividend is large and the divisor is small, or when the divisor is large

and the dividend is small. The yellow region shows the cases where both the dividend and divisor fall into the middle-range of FP16 values, which is where a numerically well-designed algorithm falls, and indicates that 98% of values are within 0.5625 ULP of being correct, and every possible combination of dividend and divisor is never less accurate than about 1.5 ULP. The only places where the approximate division breaks down is when the divisor is very small (i.e., the left-hand red strip corresponding to the denormals), or very large (that is, the right-hand red strip where the exponent is at, or close to the maximum).¹

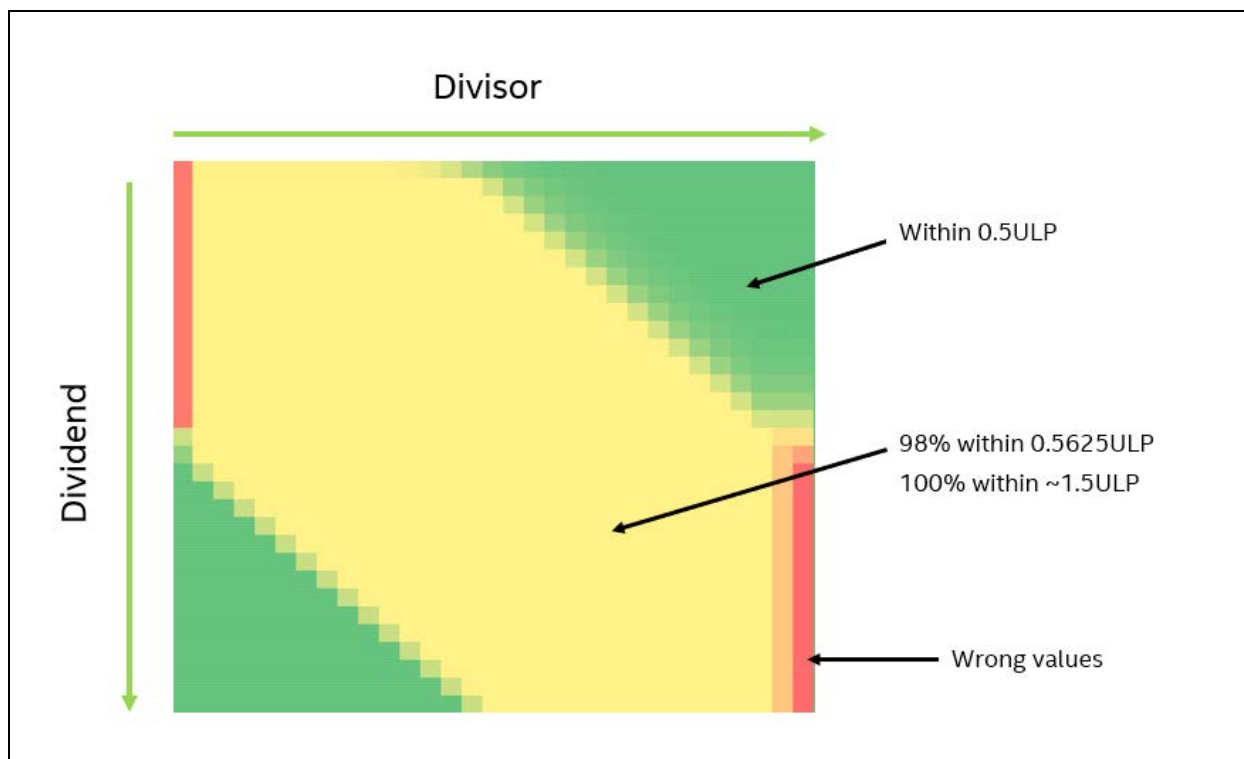

Figure 19-8. Heat-map Showing Relative ULP Error for Different Combinations of Divisor and Dividend Value Ranges

A division instruction is relatively expensive, taking 24 cycles with a throughput of 16 in 512-bit mode. In contrast, both multiply and reciprocal are cheap instructions, even when used in sequence, and consequently the approximation to division is $\sim 3x$ faster. This speed, coupled with the low error for most FP16 values, means that well-designed algorithms could use the approximation sequence with little disadvantage.

19.4.8.3 Approximate Reciprocal Square Root

The reciprocal square root instruction in Intel AVX-512 FP16 is numerically very good. It gives a value that is within 0.5 ULP for 98% of the valid inputs, and the remaining 2% are within 0.5625 ULP of the true result.

An obvious implementation of a reciprocal square root, which uses the correctly rounded operations, is shown below:

```
__m512h rsqrtSequence = _mm512_div_ph(_mm512_set1_ph(1.0f16), _mm512_sqrt_ph(x));
```

1. For workloads and configurations visit www.Intel.com/PerformanceIndex. Results may vary.

This also gives a very good answer - within 0.5 ULP of the true result for 73% of possible inputs, and within 1 ULP for the remaining 23% - but that is slightly worse than the `_mm_rsqrt_ph` instruction itself, so the approximation intrinsic should be used in preference.

The approximate reciprocal square root takes 6 cycles, compared to the alternative sequence above that takes 48 cycles when in 512-bit mode.

19.4.9 Approximate Square Root

Although a square root instruction exists and is within 0.5 ULP of the true answer, it is possible to combine a product and `rsqrt` to get a good approximation, as shown in the code fragment below:

```
__m512h sqrtSequence = _mm512_mul_ph(x, _mm512_rsqrt_ph(x));
```

This sequence gives an answer that is identical to that from the `sqrt` instruction for 70% of the possible input values and is never more than 1 ULP away from the true result for any FP16 input value. The throughput of the product is twice the throughput of the reciprocal square root approximation, allowing for some flexibility in internal scheduling. The speed of this instruction sequence, coupled with its negligible error, makes it suitable for fast `sqrt` for any algorithms except those that require guaranteed IEEE rounding.

19.5 USING EXISTING INTEL® AVX-512 INSTRUCTIONS TO AUGMENT FP16 SUPPORT

Intel AVX-512 FP16 provides purely numeric operations that require hardware support and cannot easily be implemented in any other way. For all other related operations needed to support the use of vector FP16 (for example, permuting FP16 elements in a register), it is necessary to use the instructions that are already provided as part of the existing Intel AVX-512 instruction set. As a convenience, the compiler provides many support functions. For example, the intrinsic called `_mm512_mask_blend_ph`, which blends FP16 elements from two registers into one, is implemented using the underlying `mask_blend_epi16` instruction. In cases where the compiler does not provide such convenience functions it will be necessary for programmers to create a wrapper to handle this themselves. In this section we show how such functions could be implemented, list some of the common convenience instructions, and show one example where extra performance can be achieved by exploiting the Intel AVX-512 instruction set to handle floating-point comparisons more efficiently.

19.5.1 Using Existing Instructions to Extend Intel® AVX-512 FP16 Intrinsics

Suppose we wish to use a bit mask to compress the elements of an FP16 vector register, creating something that would act as you would expect from a non-existent intrinsic called `_mm512_mask_compress_ph`. Although such an intrinsic does not exist, it can be created as shown in Example 19-4.

Example 19-4. Function to Implement the 16-Bit Compress Operation on FP16 Vector Elements

```
__m512h compress_ph(__m512h src, __mmask32 mask, __m512h value)
{
    const auto asInt16 = _mm512_castph_si512(value);
    const auto src16 = _mm512_castph_si512(src);
    const auto comp = _mm512_mask_compress_epi16(src16, mask, asInt16);
    return _mm512_casts_i512_ph(comp);
}
```

The strategy followed in the example is to take the incoming vector of FP16 values and recast to a vector of `int16_t` values using the `castph_si512` intrinsic. The newly cast values are then processed as though they are a vector of `int16_t` elements instead. This step does not change the individual 16-bit

element blocks; it just moves them around within the register. On completion, the value is recast back to its original type as a vector of FP16 elements.

Note that the cast operations have no runtime impact and are purely used to inform the compiler that the programmer is treating the underlying bits in the incoming register as though they were a different type. No type conversion takes place. In practice, the entire code sequence in the example function collapses into a single compress instruction.

This same strategy can be used to apply any sort of data movement instructions as a method of moving data around within FP16 vector registers. The code is somewhat verbose but can be easily hidden away as a library function. Furthermore, many common utility intrinsics of this sort have already been implemented in the Intel OneAPI compiler and can be used directly. It should only be necessary to build additional intrinsic support functions for more unusual operations.

In addition to data movement instructions, other bitwise operations like abs, nabs, negate, copy-sign, and so on, can also be implemented using the underlying Intel AVX-512 foundation instructions.

19.5.2 Common Convenience Intrinsics

Convenience instructions are provided for the common cases where FP16 support is implemented with existing Intel AVX-512 instructions, without requiring the definition of verbose intrinsics given in the `compress_ph` example above. Table 19-7 provides a list of some common convenience intrinsics.

Table 19-7. Conjugation Instructions

Mode	Purpose and Implementation
<code>_mm512_conj_ph</code>	Compute the conjugate of a complex number by using bitwise XOR operation to flip the sign bit of the imaginary elements.
<code>_mm512_abs_ph</code>	Compute the absolute numeric value of an FP16 element by using a bitwise AND instruction to mask off the sign bit.
<code>_mm512_mask_blend_ph</code>	Use the underlying <code>_mm512_mask_blend_epi16</code> intrinsic to provide an FP16 (<code>_ph</code>) equivalent.
<code>_mm512_permute[x]var_ph</code>	Reorder FP16 elements from one or two source registers.
<code>_mm512_reduce_[add/min/max]_ph</code>	Generate a sequence of instructions that performs a reduction operation across all the elements of an FP16 vector register. This is more complicated than the other examples because it performs a sequence of permutes and reorders to pull the data together and intersperses those operations with numeric reduction operations that perform addition, multiplication, minimum, and so on.

19.5.3 Using Integer Comparisons for Fast Floating-Point Comparison

IEEE floating-point values have the property that all non-NaN values that are either both known to be positive or known to have different signs can be directly compared by treating their bit pattern as a 16-bit signed integer. This does not work when both values are negative. The fast-integer property can be

exploited to give a low-latency minimum (or maximum) function as shown in the code fragment in Example 19-5.

Example 19-5. Function That Performs Fast Floating-Point Minimum Using Integer Instructions

```
// Assume the inputs are sane values, and either both positive or opposite signs.
__m128h fast_special_min(__m128h lhs, __m128h rhs)
{
    const auto lhsInt16 = _mm_castph_si128(lhs);
    const auto rhsInt16 = _mm_castph_si128(rhs);
    const auto smallest = _mm_min_epi16(lhsInt16, rhsInt16);
    return _mm_castsi128_ph(smallest);
}
```

By using the `int16_t` minimum instead, the instruction takes only 1 cycle to execute, which is faster than the equivalent FP16 minimum, and can be used to accelerate latency or dependency-sensitive code. Note however that the throughput is lower than the equivalent FP16 minimum instruction, so code that is exclusively performing minimum operations may do better using the FP16 minimum.¹

For comparison operations all data types take the same number of cycles to compare so using the equivalent `int16_t` form of the instruction to perform a comparison makes no difference to performance.

19.6 MATH LIBRARY SUPPORT

The math libraries provided with Intel® compilers offer full functionality for the `float16` data type (`_Float16`). Compiler support for the `float16` data type can be enabled with `-arch=sapphirerapids` (ICX compiler). `Float16`-specific optimizations are available for vectorized math library calls.

Scalar math library functionality is available in the LIBM. These functions have not yet been optimized for Intel AVX-512 FP16 and currently rely on existing `float32` implementations. Scalar `float16` function names use the `f16` suffix (for example, `expf16`, `logf16`, `sinf16`, `cosf16`).

At the default accuracy level (4 ULP or better), most common functions in the short vector math library (SVML) are optimized to take full advantage of the new Intel AVX-512 FP16 instruction set. Higher accuracy versions (1 ULP) are also available, and most have been optimized; however, the 1 ULP versions frequently rely on single precision computation to achieve the required accuracy. It is thus expected that the 4 ULP implementations will provide noticeably better performance. SVML calls are generated by the compiler as part of loop vectorization. Compiler intrinsics for SIMD `float16` calls (for example, `_mm_log_ph`) are not yet available.

The Intel AVX-512 FP16 instruction set includes several operations that support efficient implementation of math libraries. These operations are extensions of Intel AVX-512 transcendental support instructions and include `VGETEXP`, `VGETMANT`, `VSCALEF`, `VFPCLASS`, `VREDUCE`, `VRNDSCALE` (in addition to `VRCP`, `VRSQRT`).

VGETEXP (get normalized exponent) and **VGETMANT** (get normalized mantissa) are used together in implementations of functions such as `log()`, `pow()`, `cbrt()`. In the absence of these operations, denormal and special inputs would require treatment in a separate path (or alternatively, a slower main path that treats all inputs correctly). Denormals are reasonably likely to occur as inputs to `float16` SVML calls due to the narrow `float16` format range. The relative frequency of special inputs also increases with a wider SIMD length (32 packed `float16` inputs per 512-bit SIMD register), so it is especially helpful to avoid branches. As an example, `VGETEXP` and `VGETMANT` can be used to reduce the `log()` computation to `log(x)=VGETEXP(x)*log(2) + log(VGETMANT(x,8))`. `VGETMANT` with an immediate value of 8 returns the normalized mantissa (in the [1,2) range) for positive inputs, and `QNaN_Indefinite` for negative inputs (which helps with special case handling).

1. For workloads and configurations visit www.Intel.com/PerformanceIndex. Results may vary.

VSCALEF(a,b)= $a * 2^{\text{floor}(b)}$ is used in exponential and power functions; other possible applications include software division. This operation helps with correct overflow and underflow treatment in the main path. It also includes support for special exp() cases, thus eliminating the need for branches or other fixup code for this function family.

VFPCLASS is used to test for multiple special case categories (sNaN, negative finite, denormal, -Infinity, +Infinity, -0, +0, qNaN). This helps when redirecting special inputs to a secondary path (for example, in the pow() function), or to generate a fixup mask for setting special case results in the main path.

VRNDSCALE (round to specified number of fractional bits, using specified rounding mode) is used in function argument reduction, and to help generate lookup table indices (also as part of argument reduction). VRNDSCALE is a generalized form of round-to-integral, so it provides ceil/floor/trunc functionality, and also helps with floating-point remainder operations.

VREDUCE is closely related to VRNDSCALE: $VREDUCE(x, imm) = x - VRNDSCALE(x, imm)$. This instruction helps further speed up argument reduction for certain functions (for example, exp2, pow).

The existing Intel AVX-512 permute operations (VPERM, VPERMT2, VPERMI2 for 16-bit and 32-bit data) provide fast vector gather support for those implementations that need lookup tables (up to 32 16-bit entries for VPERMW, up to 64 16-bit entries for VPERMT2W/VPERMI2Wn operations).

CHAPTER 20

INTEL® ADVANCED MATRIX EXTENSIONS (INTEL® AMX)

This document aims to help low-level DL programmers optimally code to the metal on Intel® Xeon® Processors based on Sapphire Rapids SP microarchitecture. It extends the public documentation on Optimizing DL code with DL Boost instructions in Section 20.8.

It explains how to detect processor support in Intel® AMX Architecture (Section 20.1). It provides an Intel® AMX architectural overview (Section 20.2) and presents Intel AMX instruction throughput and latency (Section 20.3). It also discusses software optimization opportunities for Intel® AMX (Section 20.5 through Section 20.17), TileConfig/TileRelease and compiler ABI (Section 20.18), Intel AMX state management and system software aspects (Section 20.19), and the use of Intel AMX for higher precision GEMMs (Section 20.20). Buildable and executable versions of most code examples may be found in a public GitHub repository: <https://github.com/intel/optimization-manual>.

Table 20-1. Related Links

Description	URL
Intel® AMX architecture definition in the Intel® Architecture Instruction Set Extensions Programming Reference Guide	https://software.intel.com/content/www/us/en/develop/download/intel-architecture-instruction-set-extensions-programming-reference.html
Template Convolution C++ code for both ICC and ICX Intel Compilers and makefile	https://intel.sharepoint.com/sites/MLPerformance/mlpc/SitePages/SPR%20Eagle%20Stream.aspx
Open VINO™ Optimization Guide	https://docs.openvino.ai/latest/openvino_docs_optimization_guide_dldt_optimization_guide.html
oneDNN GitHub	https://github.com/oneapi-src/oneDNN
oneDNN documentation	https://oneapi-src.github.io/oneDNN/
Intel® Optimization TensorFlow Installation Guide	https://www.intel.com/content/www/us/en/developer/articles/guide/optimization-for-tensorflow-installation-guide.html
PyTorch Landing Page	https://pytorch.org/
PyTorch GitHub	https://github.com/pytorch/pytorch
Low Precision Optimization Tool (LPOT) GitHub	https://github.com/intel/neural-compressor
Tips for measuring the performance of matrix multiplication using Intel® MKL	https://www.intel.com/content/www/us/en/developer/articles/technical/a-simple-example-to-measure-the-performance-of-an-intel-mkl-function.html
Intel AMX ABI	https://gitlab.com/x86-psABIs/x86-64-ABI/-/wikis/x86-64-psABI
GitHub Repository	https://github.com/intel/optimization-manual
Using dynamically enabled XSTATE features in Linux user space applications	https://www.kernel.org/doc/html/latest/x86/xstate.html

Table 20-1. Related Links

Description	URL
Using dynamically enabled XSTATE features in Windows user space applications	https://docs.microsoft.com/en-us/windows/win32/api/winbase/nf-winbase-getenabledxstatefeatures
	https://docs.microsoft.com/es-es/windows/win32/api/winbase/nf-winbase-enableprocessoptionalxstatefeatures
	https://docs.microsoft.com/en-us/windows/win32/api/winbase/nf-winbase-getthreadenabledxstatefeaturesv
	https://docs.microsoft.com/en-us/windows/win32/api/process-threadsapi/nf-processthreadsapi-updateprocthreadattribute

20.1 DETECTING INTEL® AMX SUPPORT

Use the CPUID instruction described in Chapter 1.5 of the Intel® Architecture Instruction Set Extensions Programming Reference to find out whether the processor you are executing on supports Intel AMX at the hardware level.

Specifically, when issuing the CPUID instruction with EAX register set to 7 and ECX register set to 0, the instruction returns in the EDX register an indication on Intel AMX support in bits 22, 24, 25. They are all set to 0 if AMX is not supported and all set to 1 if it is supported by the processor.

Next step is check whether the OS has enabled Intel AMX state. For that you first need to issue the CPUID instruction again to check whether the OS supports the XGETBV instruction, then use it to check whether the OS has enabled Intel® AMX state save/restore.

When issuing the CPUID instruction with EAX register set to 1, the instruction returns in the ECX register an indication on XGETBV support in bit 26. If bit 26 is set, when issuing the XGETBV instruction with ECX register set to 0, the instruction returns an indication on OS support in saving and restoring Intel AMX state in bits 17 and 18 of the EAX register. Both bits should be set in order to use the Intel® AMX instructions. There's additional CPUID information on Intel AMX which can be found in <https://software.intel.com/content/www/us/en/develop/download/intel-architecture-instruction-set-extensions-programming-reference.html>.

Operating systems may require calling an OS API to allocate Intel AMX state. See <https://docs.microsoft.com/en-us/windows/win32/api/winbase/nf-winbase-getenabledxstatefeatures> for Linux API and <https://docs.microsoft.com/es-es/windows/win32/api/winbase/nf-winbase-enableprocessoptionalxstatefeatures> for Windows API. More on Intel AMX state management in Section 20.19 of this document.

20.2 INTEL® AMX MICROARCHITECTURE OVERVIEW

General AMX micro-architecture overview is available in Chapter 3 of the Intel® Architecture Instruction Set Extensions Programming Reference.

20.2.1 INTEL AMX FREQUENCIES

Discussion on the connection between max frequency, frequency license, and Instruction Set Architecture covering technologies up to AVX-512 Instruction Set, is available in section 2.4.3 of IA Optimization Guide. Intel AMX adds yet another license level whose max frequency is usually lower than that of AVX-512 license.

When the Intel AMX unit utilization is lower than 15%, the processor may exceed the nominal max frequency associated with Intel AMX license.

20.3 INTEL® AMX INSTRUCTIONS THROUGHPUT AND LATENCY

Several Intel AMX instructions are available. Two instructions (TileLoad*) load data from the memory hierarchy into the tile registers and one instruction (TileStore) stores the contents of a tile register into the DCU (Data Cache Unit—first level cache). Other instructions (TDP*) execute the matrix multiplication, operating on two input tile registers and writing the result into a third tile register. Additionally, there are some less-frequently used instructions. The following table provides the instruction throughput and latency counted in cycles.

Table 20-2. Intel® AMX Instruction Throughput and Latency

Instruction	Throughput	Latency
LDTILECFG		204
STTILECFG		19
TILERELEASE		13
TDP/*	16	52
TILELOADD	8	45
TILELOADDT1	23	48
TILESTORED	16	
TILEZERO	0	16

NOTE

Due to the high latency of the LDTILECFG instruction we recommend issuing a single pair of LDTILECFG and TILERELEASE operations per Intel AMX-based DL layer implementation.

20.4 DATA STRUCTURE ALIGNMENT

GEMM and Convolution input/output data structures must be 64-byte aligned for optimal performance but should not be aligned to 128-byte, 256-byte, etc. For more details, see Tip 6 in *Tips for Measuring the Performance of Matrix Multiplication Using Intel® MKL*.

20.5 GEMMS / CONVOLUTIONS

20.5.1 NOTATION

The following notation is used for the matrices (A, B, C) and the dimensions (M, K, N) in matrix multiplication (GEMM).

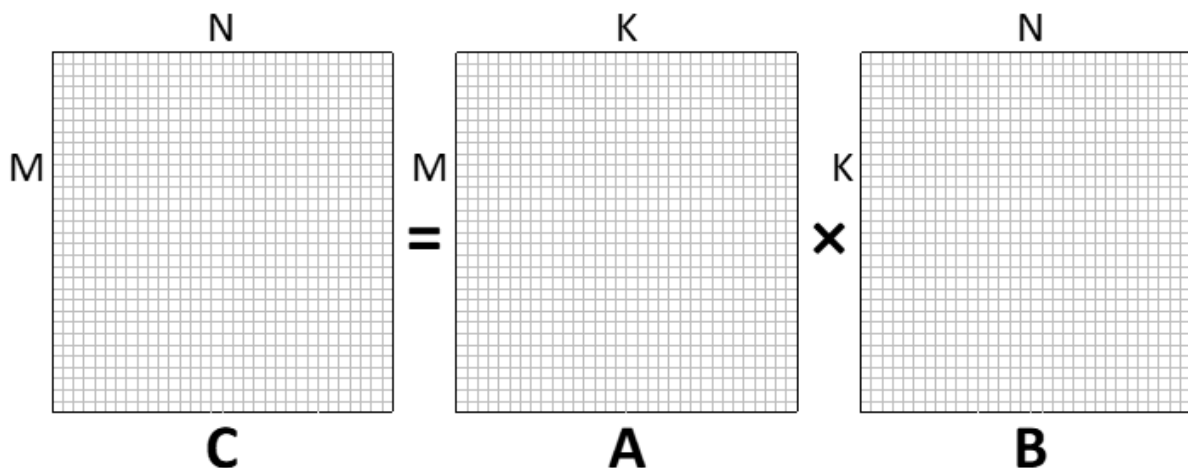

Figure 20-1. Matrix Notation

20.5.2 TILES IN THE INTEL® AMX ARCHITECTURE

The Intel AMX instruction set operates on tiles: large two-dimensional registers with configurable dimensions. The configuration is dependent on the type of tile.

- **A-tiles** can have between 1-16 rows and 1-MAX_TILE_K columns.
- **B-tiles** can have between 1-MAX_TILE_K rows and 1-16 columns.
- **C-tiles** can have between 1-16 rows and 1-16 columns.

$\text{MAX_TILE_K} = 64 / \text{sizeof}(\text{type_t})$, and type_t is the type of the data being operated on. Therefore, $\text{MAX_TILE_K} = 64$ for (u)int8 data, and $\text{MAX_TILE_K} = 32$ for bfloat16 data. The dimensions here are mathematical/logical. For mapping to tile register configuration parameters, see the Intel® Architecture Instruction Set Extensions Programming Reference referenced in Section 20.2.

The type of data residing in the tiles also varies depending on the type of tile.

A tiles and B tiles contain data of type_t , which can be (u)int8 or bfloat16.

- C tiles contain data of type res_type_t :
- int32 if $\text{type_t} = (\text{u})\text{int8}$
- float if $\text{type_t} = \text{bfloat16}$

Thus, a maximum-sized tile multiplication operation for (u)int8 data type looks this way:

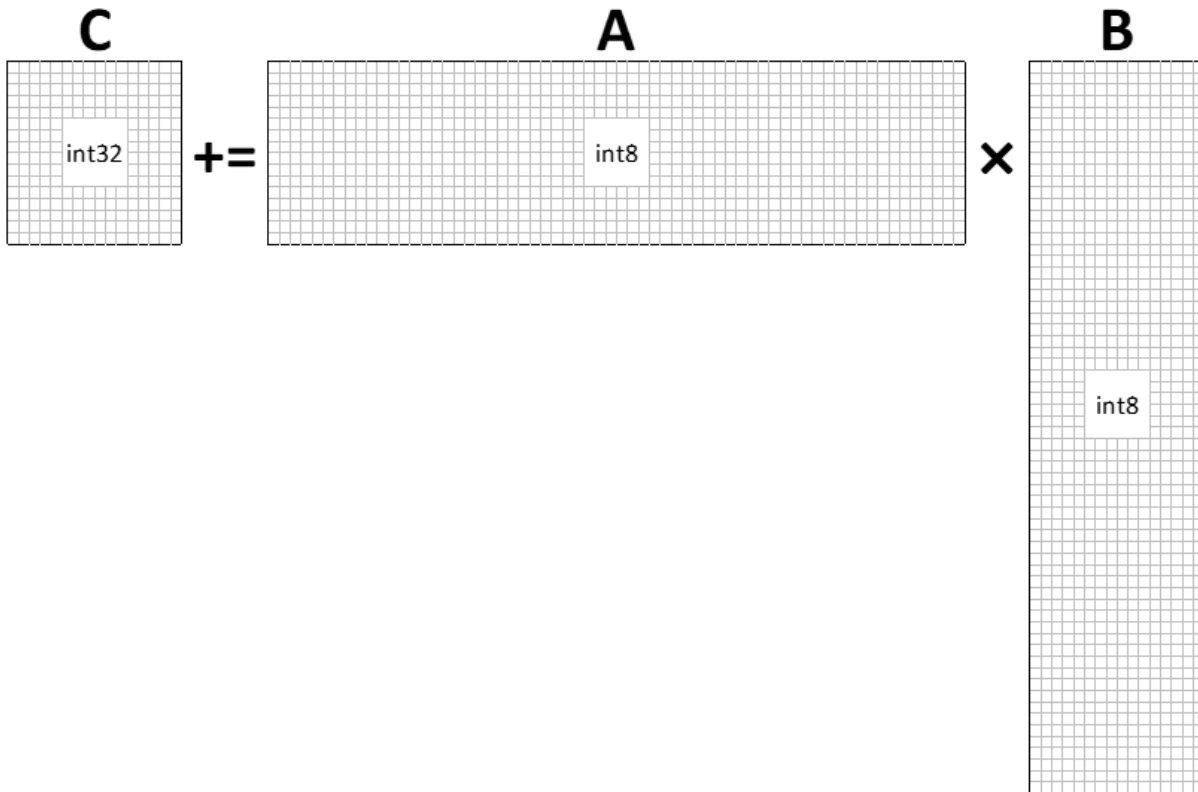

Figure 20-2. Intel® AMX Multiplication with Max-sized int8 Tiles

TileLoad and TileStore Instructions

The tiles are loaded from memory with the TileLoad instruction and stored to memory with a TileStore instruction. The TileLoad/TileStore instructions receive the following parameters:

- The destination/source tile of the TileLoad/TileStore.
- The source/destination location in memory for the TileLoad/TileStore.
- The stride (bytes) in memory between subsequent rows of the tile.

Lines 6–10 in Example 20-1 illustrate how a tile is loaded from memory.

Example 20-1. Pseudo-code for the Tilezero, TileLoad, and TileStore Instructions

```
template<size_t rows, size_t bytes_cols> class tile {
public:
    friend void tilezero(tile& t) {
        memset(t.v, 0, sizeof(v));
    }
    friend void tileload(tile& t, void* src, size_t bytes_stride) {
        for (size_t row = 0; row < rows; ++row)
            for (size_t bcol = 0; bcol < bytes_cols; ++bcol)
                t.v[row][bcol] = static_cast<int8_t*>(src)[row*bytes_stride + bcol];
    }
    friend void tilestore(tile& t, void* dst, size_t bytes_stride) {
        for (size_t row = 0; row < rows; ++row)
            for (size_t bcol = 0; bcol < bytes_cols; ++bcol)
                static_cast<int8_t*>(dst)[row*bytes_stride + bcol] = t.v[row][bcol];
    }
}
template <class TC, class TA, class TB>
friend void tdp(TC &tC, TA &tA, TB &tB);
private:
    int8_t v[rows][bytes_cols];
};

// clang-format on

template <class TC, class TA, class TB> void tdp(TC &tC, TA &tA, TB &tB)
}
```

For the sake of readability, a tile template class abstraction is introduced. The number of rows in the tile and the number of column bytes per row parametrizes the abstraction.

20.5.3 B MATRIX LAYOUT

Like the Intel® DL Boost use case, the B matrix must undergo a re-layout before it can be used within the corresponding Intel AMX multiply instruction. The re-layout procedure is as follows:

Example 20-2. B Matrix Re-layout Procedure

```
#define KPACK (4/sizeof(type_t)) // Vertical K packing into Dword

type_t B_mem_orig[K][N]; // Original B matrix
type_t B_mem[K/KPACK][N][KPACK]; // Re-laid B matrix

for (int k = 0; k < K; ++k)
    for (int n = 0; n < N; ++n)
        B_mem[k/KPACK][n][k%KPACK] = B_mem_orig[k][n];
```

The following figures illustrate the data re-layout process for a 64x16 int8 B matrix and a 32x16 bfloat16 B matrix (corresponding to the maximum-sized B-tile):

Figure 20-3. Re-layout of 64x16 int8 B Matrix

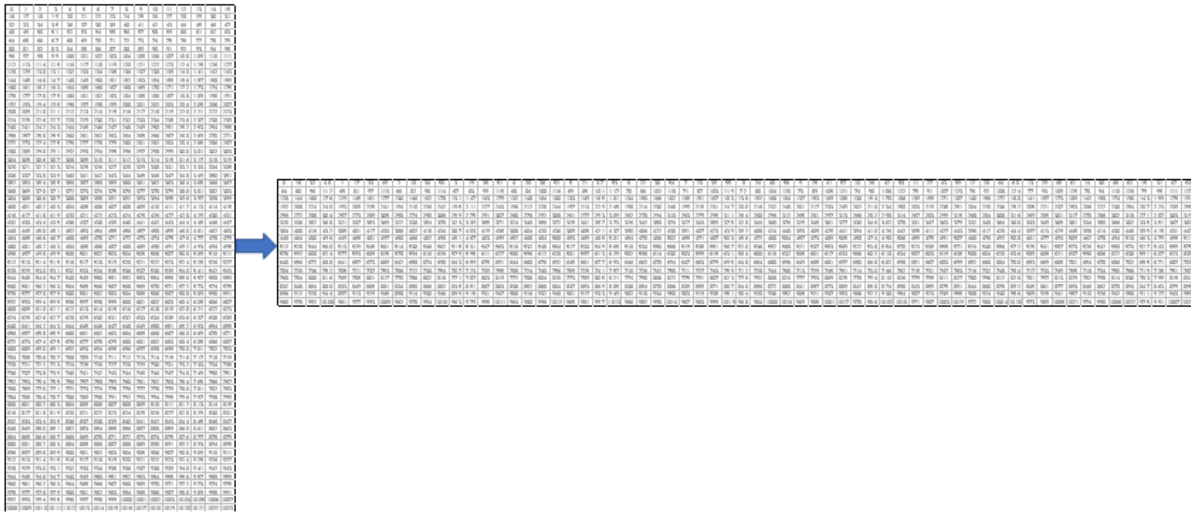
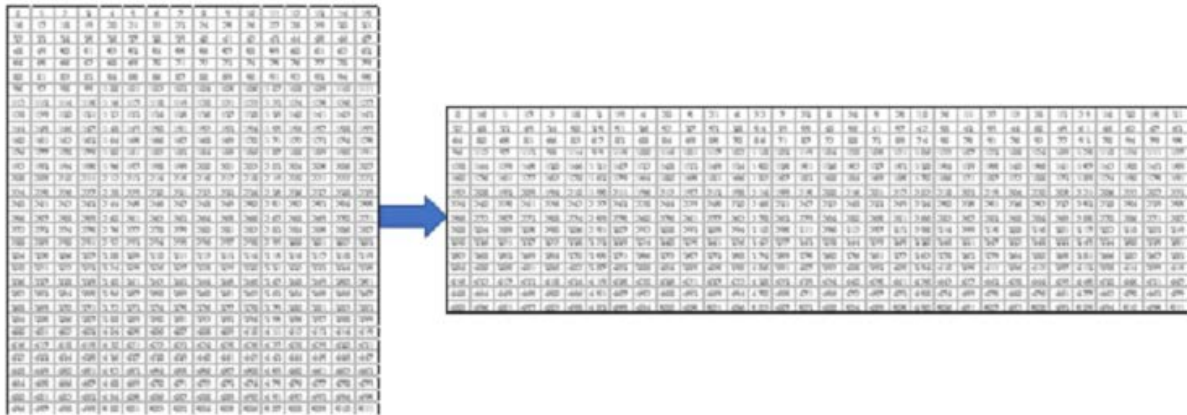

Figure 20-4. Re-layout of 32x16 bfloat16 B Matrix



20.5.4 STRAIGHTFORWARD GEMM IMPLEMENTATION

This is GEMM reference code. Its performance is sub-optimal. Please refer to Section 20.5.5.3 for optimal GEMM code. Begin implementation by defining the following:

Example 20-3. Common Defines

```

1  #define M ...           // Number of rows in the A or C matrices
2  #define K ...           // Number of columns in the A or rows in the B matrices
3  #define N ...           // Number of columns in the B or C matrices
4  #define M_ACC ...      // Number of C accumulators spanning the M dimension
5  #define N_ACC ...      // Number of C accumulators spanning the N dimension
6  #define TILE_M ...     // Number of rows in an A or C tile
7  #define TILE_K ...     // Number of columns in an A tile or rows in a B tile
8  #define TILE_N ...     // Number of columns in a B or C tile
9
10 typedef ... type_t;     // The type of data being operated on
11 typedef ... res_type_t; // The data type of the result
12
13 #define KPACK (4/sizeof(type_t)) // Vertical K packing into Dword
14
15 type_t A_mem[M][K];      // A matrix
16 type_t B_mem[K/KPACK][N][KPACK]; // B matrix
17 res_type_t C_mem[M][N]; // C matrix
18
19 template<size_t rows, size_t bytes_cols> class tile;
20 template<class T> void tilezero (T& t);
21 template<class T> void tileload (T& t, void* src, size_t stride);
22 template<class T> void tilestore(T& t, void* dst, size_t stride);
23 template <class TC, class TA, class TB> void tdp(TC &tC, TA &tA, TB &tB) {
24     int32_t v;
25     for (size_t m = 0; m < TILE_M; m++) {
26         for (size_t k = 0; k < TILE_K / KPACK; k++) {
27             for (size_t n = 0; n < TILE_N; n++) {
28                 memcpy(&v, &tC.v[m][n * 4], sizeof(v));
29                 v += tA.v[m][k * 4] * tB.v[k][n * 4];
30                 v += tA.v[m][k * 4 + 1] * tB.v[k][n * 4 + 1];
31                 v += tA.v[m][k * 4 + 2] * tB.v[k][n * 4 + 2];
32                 v += tA.v[m][k * 4 + 3] * tB.v[k][n * 4 + 3];
33                 memcpy(&tC.v[m][n * 4], &v, sizeof(v));
34             }
35         }
36     }
37 }

```

Data type `type_t` is the type being operated upon, i.e., signed/unsigned `int8` or `bfloat16`. For the description of `KPACK`, see Section 20.5.5. The tile template class and the three functions that operate on it are the same as the ones introduced in Example 20-3. `tilezero (t)` resets the contents of tile `t` to 0, `tileload(t, src, stride)` and loads tile `t` with the contents of data at `src` with a stride of `stride` between consecutive rows. `tilestore(t, dst, stride)` stores the contents of tile `t` to `dst` with a stride of `stride` between consecutive rows. Additionally, `tdp(tC, tA, tB)` performs a matrix multiplication equivalent of `tC=tC+tAxB`. In reality, tiles are defined by known compile-time integers, and the actual code operating on tiles looks slightly different. **See code templates for usage.**

The following is a simple implementation of GEMM of the matrices stored in `A_mem` and `B_mem`.

Example 20-4. Reference GEMM Implementation

```

for (int n = 0; n < N; n += N_ACC*TILE_N) {
  for (int m = 0; m < M; m += M_ACC*TILE_M) {
    tile<TILE_M, TILE_N*sizeof(res_type_t)> tC[M_ACC][N_ACC];
    for (int n_acc = 0; n_acc < N_ACC; ++n_acc)
      for (int m_acc = 0; m_acc < M_ACC; ++m_acc)
        tilezero(tC[m_acc][n_acc]);

    for (int k = 0; k < K; k += TILE_K) {
      for (int n_acc = 0; n_acc < N_ACC; ++n_acc) {
        tile<TILE_K/KPACK, TILE_N*KPACK> tB;
        tileload(tB, B_mem[k/KPACK][n + n_acc*TILE_N], N*sizeof(type_t)*KPACK);
        for (int m_acc = 0; m_acc < M_ACC; ++m_acc) {
          tile<TILE_M, TILE_K*sizeof(type_t)> tA;
          tileload(tA, &A_mem[m + m_acc*TILE_M][k], K*sizeof(type_t));
          tdp(tC[m_acc][n_acc], tA, tB);
        }
      }
    }
    for (int n_acc = 0; n_acc < N_ACC; ++n_acc) {
      for (int m_acc = 0; m_acc < M_ACC; ++m_acc) {
        int mc = m + m_acc*TILE_M, nc = n + n_acc*TILE_N;
        tilestore(tC[m_acc][n_acc], &C_mem[mc][nc], N*sizeof(res_type_t));
      }
    }
  }
}

```

This implementation is the reference point in the following discussions.

20.5.5 OPTIMIZATIONS

20.5.5.1 Minimizing Tile Loads

Redundant tile loads may severely impact performance due to the large size of the data loaded into the tiles, unnecessary cache evictions, etc. To minimize tile loads, it is essential to utilize the data as completely as possible once it has been loaded into the tile.

Location of the K Loop: Outside of the M_ACC and N_ACC Loops

The three loops in lines 8–18 of Example 20-4 could also have been written this way:

Example 20-5. K-dimension Loop as Innermost Loop—A highly inefficient approach

```
for (int n_acc = 0; n_acc < N_ACC; ++n_acc) {
  tile<TILE_K/KPACK, TILE_N*KPACK> tB;
  for (int m_acc = 0; m_acc < M_ACC; ++m_acc) {
    tile<TILE_M, TILE_K*sizeof(type_t)> tA;
    for (int k = 0; k < K; k += TILE_K) {
      tileload(tB, B_mem[k/KPACK][n + n_acc*TILE_N], N*sizeof(type_t)*KPACK);
      tileload(tA, &A_mem[m + m_acc*TILE_M][k], K*sizeof(type_t));
      tdp(tC[m_acc][n_acc], tA, tB);
    }
  }
}
```

While both approaches yield correct results, there are $K/\text{TILE_K} \times \text{N_ACC}$ B tile loads in the reference implementation. Additionally, $K/\text{TILE_K} \times \text{N_ACC} \times \text{M_ACC}$ B tile loads in the implementation presented in this section. The number of A tile loads is identical.

This approach is also characterized by excessive pressure on the memory along with an increased number of tile loads.

Suppose the `B_mem` data resides in main memory. In the reference implementation, a new chunk of $\text{TILE_K} \times \text{TILE_N}$ B data is read every `M_ACC` iteration of the inner loop. The inner loop then reuses the read data. In the current implementation, when `n_acc == m_acc == 0`, a new chunk of $\text{TILE_K} \times \text{TILE_N}$ B data is read every iteration of the inner loop. Then the same data is read (presumably from caches) on subsequent iterations of `n_acc`, `m_acc`. This burst access pattern of reads from main memory results in increased data latency and decreased performance.

Hence, keeping the K-dimension loop outside the `M_ACC` and `N_ACC` loops is recommended.

Pre-loading Innermost Loop Tiles

Consider the following replacement code for the code in lines 8–18 of Example 20-4:

Example 20-6. Innermost Loop Tile Pre-loading

```

1   for (int k = 0; k < K; k += TILE_K) {
2     tile<TILE_M, TILE_K*sizeof(type_t)> tA[M_ACC];
3     for (int m_acc = 0; m_acc < M_ACC; ++m_acc)
4       tileload(tA[m_acc], &A_mem[m + m_acc*TILE_M][k], K*sizeof(type_t));
5     for (int n_acc = 0; n_acc < N_ACC; ++n_acc) {
6       tile<TILE_K/KPACK, TILE_N*KPACK> tB;
7       tileload(tB, B_mem[k/KPACK][n + n_acc*TILE_N], N*sizeof(type_t)*KPACK);
8       for (int m_acc = 0; m_acc < M_ACC; ++m_acc) {
9         tdp(tC[m_acc][n_acc], tA[m_acc], tB);
10      }
11    }
12  }

```

The A-tile has been extended to an array of A-tiles (line 2) and pre-read the A tiles for the current K-loop iteration (lines 3–4). A pre-read A-tile is used in the tile multiplication (line 9). There were $K/\text{TILE_K} \times \text{N_ACC} \times \text{M_ACC}$ A-tile reads in the reference implementation, while there are only $K/\text{TILE_K} \times \text{M_ACC}$ A-tile reads in the current implementation.

Hence, pre-allocation and pre-reading the tiles of the innermost loop (tA[M_ACC] in this case) is recommended. The maximum number of tiles used at any given time in this scenario is $\text{N_ACC} \times \text{M_ACC} + \text{M_ACC} + 1$ as opposed to $\text{N_ACC} \times \text{M_ACC} + 2$ in the reference implementation. Since this optimization requires pre-allocation of an additional $\text{M_ACC} - 1$ tiles, and since tiles are a scarce resource, if $\text{N_ACC} < \text{M_ACC}$, it might prove beneficial to switch the order of the N_ACC and M_ACC loops. This way, it is possible to allocate $\text{N_ACC} - 1 < \text{M_ACC} - 1$ additional tiles:

Example 20-7. Switched Order of M_ACC and N_ACC Loops

```

for (int k = 0; k < K; k += TILE_K) {
  tile<TILE_K/KPACK, TILE_N*KPACK> tB[N_ACC];
  for (int n_acc = 0; n_acc < N_ACC; ++n_acc)
    tileload(tB[n_acc], B_mem[k/KPACK][n + n_acc*TILE_N], N*sizeof(type_t)*KPACK);
  for (int m_acc = 0; m_acc < M_ACC; ++m_acc) {
    tile<TILE_M, TILE_K*sizeof(type_t)> tA;
    tileload(tA, &A_mem[m + m_acc*TILE_M][k], K*sizeof(type_t));
    for (int n_acc = 0; n_acc < N_ACC; ++n_acc) {
      tdp(tC[m_acc][n_acc], tA, tB[n_acc]);
    }
  }
}

```

2D Accumulator Array vs. 1D Accumulator Array

Consider Example 20-6 with the following scenarios:

- $\text{N_ACC}=2, \text{M_ACC}=2$
- $\text{N_ACC}=4, \text{M_ACC}=1$

As stated before, the number of A tile loads in lines 3–11 is M_ACC , and the number of B tile loads is N_ACC . Thus, the total number of tile loads ($\text{M_ACC} + \text{N_ACC}$) is 4 in the first scenario vs. 5 in the second one (an increase of 25%), even though both scenarios perform the same amount of work.

Hence, using 2D accumulator arrays is recommended. Selecting dimensions close to square is particularly recommended (since $x=y$ minimizes $f(x,y)=x+y$ under the constraint $x \times y = \text{const}$).

20.5.5.2 Software Pipelining of Tile Loads and Stores

It is a best practice to interleave instructions using different resources so they may be executed in parallel, preventing a bottleneck involving a specific resource. Therefore, preventing sequential TileLoads and TileStores (see lines 19–23 of Example 20-4 and lines 3–4 of Example 20-6) is recommended. Instead, interleave them with the tdp instructions (see Example 20-8).

20.5.5.3 Optimized GEMM Implementation

Below is the original code from Example 20-4, augmented with the insights from Example 20-6, with tile loads and stores interleaved with tdp:

Example 20-8. Optimized GEMM implementation

```

1 for (int n = 0; n < N; n += N_ACC*TILE_N) {
2   for (int m = 0; m < M; m += M_ACC*TILE_M) {
3     tile<TILE_M, TILE_N*sizeof(res_type_t)> tC[M_ACC][N_ACC];
4     tile<TILE_M, TILE_K*sizeof(type_t)> tA[M_ACC];
5     tile<TILE_K/KPACK, TILE_N*KPACK> tB;
6
7     for (int n_acc = 0; n_acc < N_ACC; ++n_acc)
8       for (int m_acc = 0; m_acc < M_ACC; ++m_acc)
9         tilezero(tC[m_acc][n_acc]);
10
11    for (int k = 0; k < K; k += TILE_K) {
12      for (int n_acc = 0; n_acc < N_ACC; ++n_acc) {
13        tileload(tB, B_mem[k/KPACK][n + n_acc*TILE_N], N*sizeof(type_t)*KPACK);
14        for (int m_acc = 0; m_acc < M_ACC; ++m_acc) {
15          if (n_acc == 0)
16            tileload(tA[m_acc], &A_mem[m + m_acc*TILE_M][k], K*sizeof(type_t));
17          tdp(tC[m_acc][n_acc], tA[m_acc], tB);
18          if (k == K - TILE_K) {
19            int mc = m + m_acc*TILE_M, nc = n + n_acc*TILE_N;
20            tilestore(tC[m_acc][n_acc], &C_mem[mc][nc], N*sizeof(res_type_t));
21          }
22        }
23      }
24    }
25  }
26}

```

While placing the tile loads and stores under conditions inside the main loop (lines 13, 16, 20), conditions can be eliminated by sufficiently unrolling the loops.

The rest of this section presents a specific example of GEMM, implemented in low-level Intel AMX instructions. This is to show a full performance potential from using Intel AMX extensions.

Example 20-9. Dimension of matrices, data types and tile sizes

```
#define M 32
#define K 128
#define N 32
#define M_ACC 2
#define N_ACC 2
#define TILE_M 16
#define TILE_K 64
#define TILE_N 64

typedef int8_t type_t
typedef int32_t res_type_t
```

The code below is a specific example of the algorithm outlined in Example 20-8.

Example 20-10. Optimized GEMM Assembly Language Implementation

```

1  typedef struct {
2      uint8_t palette_id;
3      uint8_t startRow;
4      uint8_t reserved[14];
5      uint16_t cols[16];
6      uint8_t rows[16];
7  } __attribute__((__packed__)) tileconfig_t;
8
9  static const tileconfig_t tc = {
10     1,                                // palette_id
11     0,                                // startRow
12     0, 0, 0, 0, 0, 0, 0, 0, 0, 0, 0, 0, 0, 0, 0, 0, // reserved - must be
13     64, 64, 64, 64, 64, 64, 64, 64, 0, 0, 0, 0, 0, 0, 0, 0, // calls for 7 tiles used
14     16, 16, 16, 16, 16, 16, 16, 16, 0, 0, 0, 0, 0, 0, 0, 0 // rows for 7 tiles used
15 };
16
17 _amx_interleaved_gemm_ass:
18 amx_interleaved_gemm_ass:
19 ldtilecfg tc                        # Load tile config
20 mov r8, A_mem                        # Initialize register for A
21 mov r9, B_mem                        # Initialize register for B
22 mov r10, C_mem                       # Initialize register for C
23
24 mov r11, 128                          # Initialize register for strides
25 tileloadd tmm6, [r9 + r11*1]          # Load B for n_acc = 0, k_acc = 0
26 tileloadd tmm4, [r8 + r11*1]          # Load A for m_acc = 0, k_acc = 0
27 tilezero tmm0                         # Zero accumulator tile
28 tdpbssd tmm0, tmm4, tmm6              # Multiply-add tmm0 += tmm4 * tmm6
29 tileloadd tmm5, [r8 + r11*1 + 2048]  # Load A for m_acc = 1, k_acc = 0
30 tilezero tmm1                         # Zero accumulator tile
31 tdpbssd tmm1, tmm5, tmm6              # Multiply-add tmm1 += tmm5 * tmm6
32 tileloadd tmm6, [r9 + r11*1 + 64]    # Load B for n_acc = 1, k_acc = 0
33 tilezero tmm2                         # Zero accumulator tile
34 tdpbssd tmm2, tmm4, tmm6              # Multiply-add tmm2 += tmm4 * tmm6
35 tilezero tmm3                         # Zero accumulator tile
36 tdpbssd tmm3, tmm5, tmm6              # Multiply-add tmm3 += tmm5 * tmm6
37 tileloadd tmm6, [r9 + r11*1 + 2048]  # Load B for n_acc = 0, k_acc = 1
38 tileloadd tmm4, [r8 + r11*1 + 64]    # Load A for m_acc = 0, k_acc = 1
39 tdpbssd tmm0, tmm4, tmm6              # Multiply-add tmm0 += tmm4 * tmm6
40 tilestored [r10 + r11*1], tmm0        # Store C for m_acc = 0, n_acc = 0
41 tileloadd tmm5, [r8 + r11*1 + 2112]  # Load A for m_acc = 1, k_acc = 1
42 tdpbssd tmm1, tmm5, tmm6              # Multiply-add tmm1 += tmm5 * tmm6
43 tilestored [r10 + r11*1 + 2048], tmm1 # Store C for m_acc = 1, n_acc = 0
44 tileloadd tmm6, [r9 + r11*1 + 2112]  # Load B for n_acc = 1, k_acc = 1
45 tdpbssd tmm2, tmm4, tmm6              # Multiply-add tmm2 += tmm4 * tmm6
46 tilestored [r10 + r11*1 + 64], tmm2  # Store C for m_acc = 0, n_acc = 1
47 tdpbssd tmm3, tmm5, tmm6              # Multiply-add tmm3 += tmm5 * tmm6
48 tilestored [r10 + r11*1 + 2112], tmm3 # Store C for m_acc = 1, n_acc = 1
49 }

```

Lines 1-12 in Example 20-10 define the tile configuration for this example, and contain information about tile sizes. Tile configuration should be loaded prior to any execution of Intel AMX instructions (line 16). Tile sizes are defined by the configuration at the load time and can't be changed dynamically (unless TileRelease is called). The 'palette_id' field in the configuration specifies the number of logical tiles available for use; palette_id == 1 means 8 logical tiles are available, named tmm0 through tmm7. This particular example uses 7 logical tiles (tmm4, tmm5 for A, tmm6 for B, tmm0-tmm3 for C).

According to the dimensions specified, K-loop consists of 2 iterations (cf. code listing 8.1, line 11) according to the dimensions specified in the example. Lines 23-34 implement the first iteration and lines 35-46 the second iteration. Note the interleaving of tdp and TileStore instructions to hide the high cost of TileStore operation.

Variable Input Dimensions

The code in Example 20-8 and 20-10 process an entire matrix of inputs of size MxK. Sometimes, only part of the input is significant, so it is beneficial to adapt the computation to the actual input size. Often, topologies that use self-attention it is enough to process only the first m rows of the input that are significant, where $m < M$. For example, taking the GEMM dimensions described above with the choice of a 1D accumulator array of $N_ACC=2, M_ACC=1$, when accepting data as input with at most sixteen significant rows, we can degenerate the m loop (line 2 in Example 20-8) so as to effectively reduce the computation by half.

It is worth noting that in variable M dimension use cases there is an advantage to 1D accumulators. Up to $N_ACC=6, M_ACC=1$ dimensions are possible if N is 96 or larger, one tile for A, one tile for B and six tiles for the accumulator.

20.5.5.4 Direct Convolution with Intel® AMX

Direct convolution is performed directly on the input data; no data replication is required. However, there are some layout considerations.

Activations Layout

Similar to the Intel DL Boost use case, the activations are laid out in a layout obtained from the original layout by the following procedure:

Example 20-11. Activations Layout Procedure

```
#define K C           // K-dimension of the A matrix = channels
#define M H*W        // M-dimension of the A matrix = spatial
type_t A_mem_orig[C][H][W]; // Original activations tensor
type_t A_mem[H][W][K];     // Re-laid A matrix

for (int c = 0; c < C; ++c)
  for (int h = 0; h < H; ++h)
    for (int w = 0; w < W; ++w)
      A_mem[h][w][c] = A_mem_orig[c][h][w];
```

This procedure on the left side of the diagram below shows the conversion of a 3-dimensional tensor into a 2-dimensional matrix:

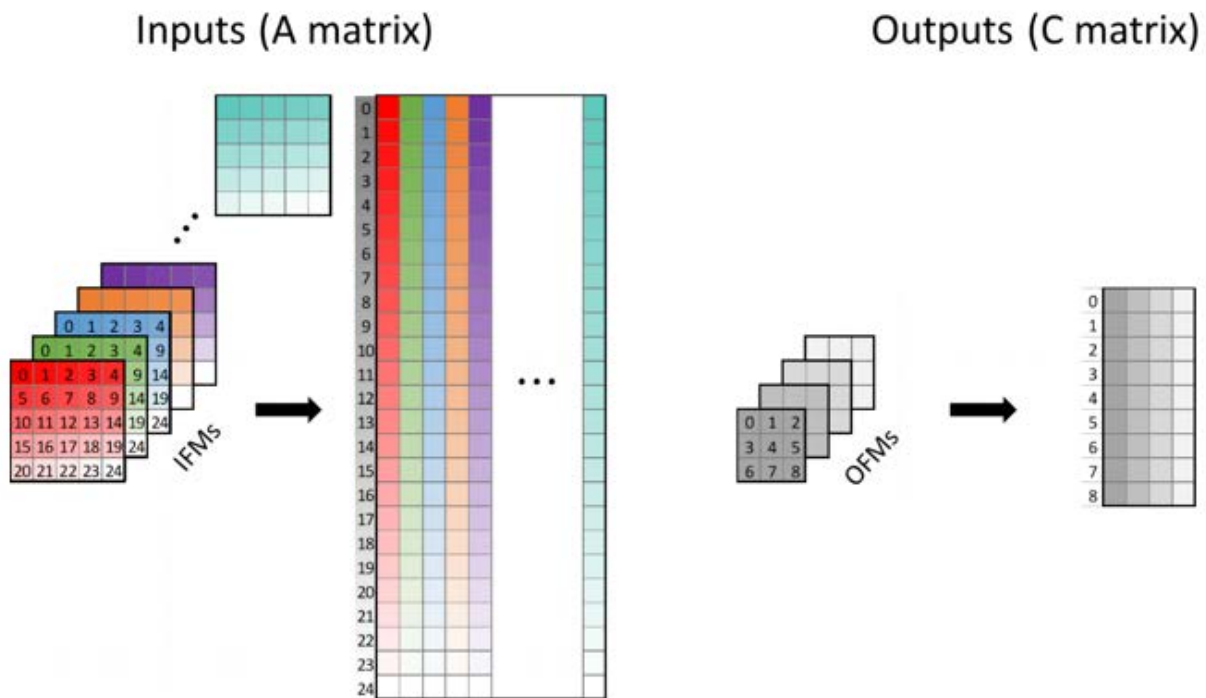

Figure 20-5. Activations layout

The procedure shown on the right is identical for the outputs, e.g., the activations of the next layer in the topology).

Weights Layout

Similar to the Intel DL Boost use case, the weights are re-laid by the following procedure:

Example 20-12. Weights Re-Layout Procedure

```
#define KH ... // Vertical dimension of the weights
#define KW ... // Horizontal dimension of the weights
#define KPACK (4/sizeof(type_t)) // Vertical K packing into Dword

type_t B_mem_orig[K][N][KH][KW]; // Original weights
type_t B_mem[KH][KW][K/KPACK][N][KPACK]; // Re-laid B matrices

for (int kh = 0; kh < KH; ++kh)
  for (int kw = 0; kw < KW; ++kw)
    for (int k = 0; k < K; ++k)
      for (int n = 0; n < N; ++n)
        B_mem[kh][kw][k/KPACK][n][k%KPACK] = B_mem_orig[k][n][kh][kw];
```

The procedure transforms the original 4-dimensional tensor into a series of 2-dimensional matrices (a single matrix is highlighted in orange in Example 20-12) as illustrated in the following diagram for $KH=KW=3$, resulting in a series of 9 B-matrices:

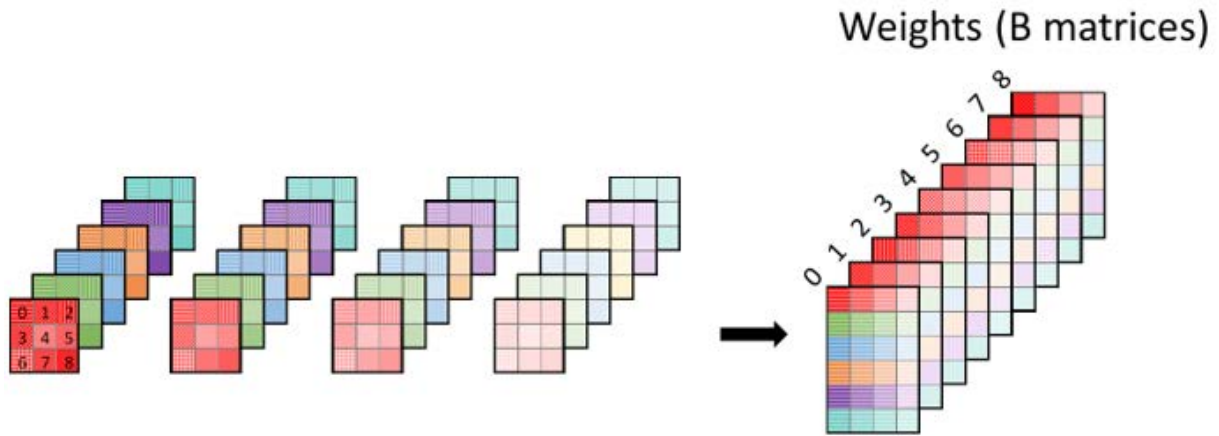

Figure 20-6. Weights Re-Layout

20.5.5.5 Convolution - Matrix-like Multiplications and Summations Equivalence

Figure 20-7 illustrates the equivalence between convolution and summation of a series of matrix-like multiplications between subsets of the 2-dimensional A-matrix representing the 3-dimensional activations tensor. The 2-dimensional B-matrices correspond to the various spatial elements of the weights filter.

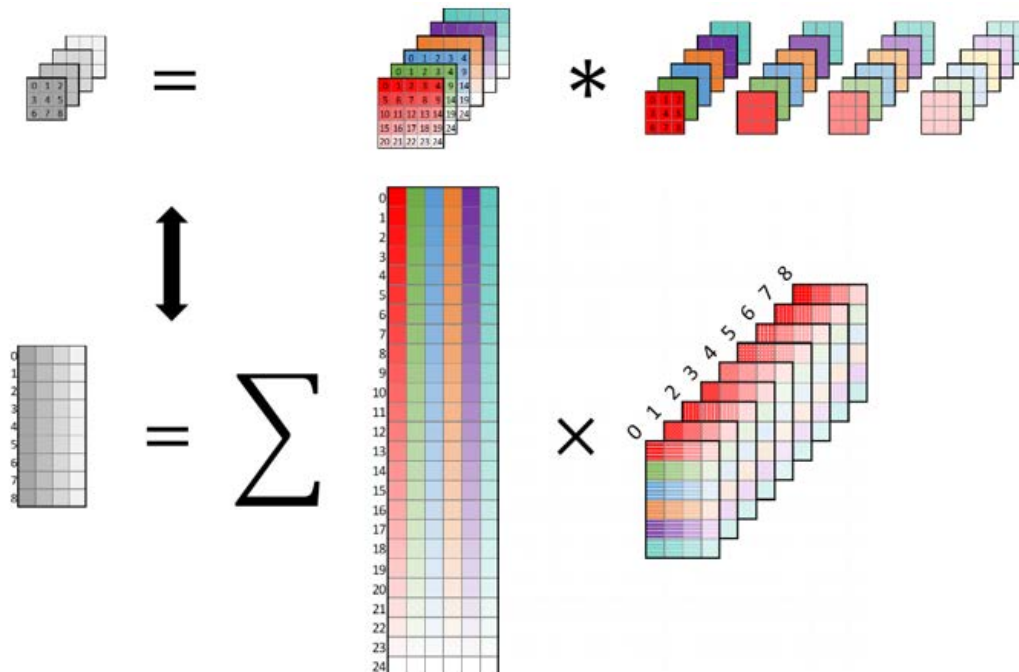

Figure 20-7. Convolution - Matrix Multiplication and Summation Equivalence

The A-matrix subset participating in the matrix-like multiplication depends on the spatial weight element in question (i.e., the kh, kw coordinates, or the index in the range 0–8 in the previous example). For each weight element, the A-matrix’s participating rows will interact with the weight element when the filter is slid over the activations. For example, when sliding the filter over the activations in the previous example, weight element 0 will only interact with activation elements 0, 1, 2, 5, 6, 7, 10, 11, and 12. For example, it will not interact with activation element four because when the filter is applied in such a manner (i.e., weight element 0 interacts with activation element 4), weight elements 2, 5, and 8 leave the activation frame entirely. The A-matrix subsets for several weight elements are illustrated in the following figure.

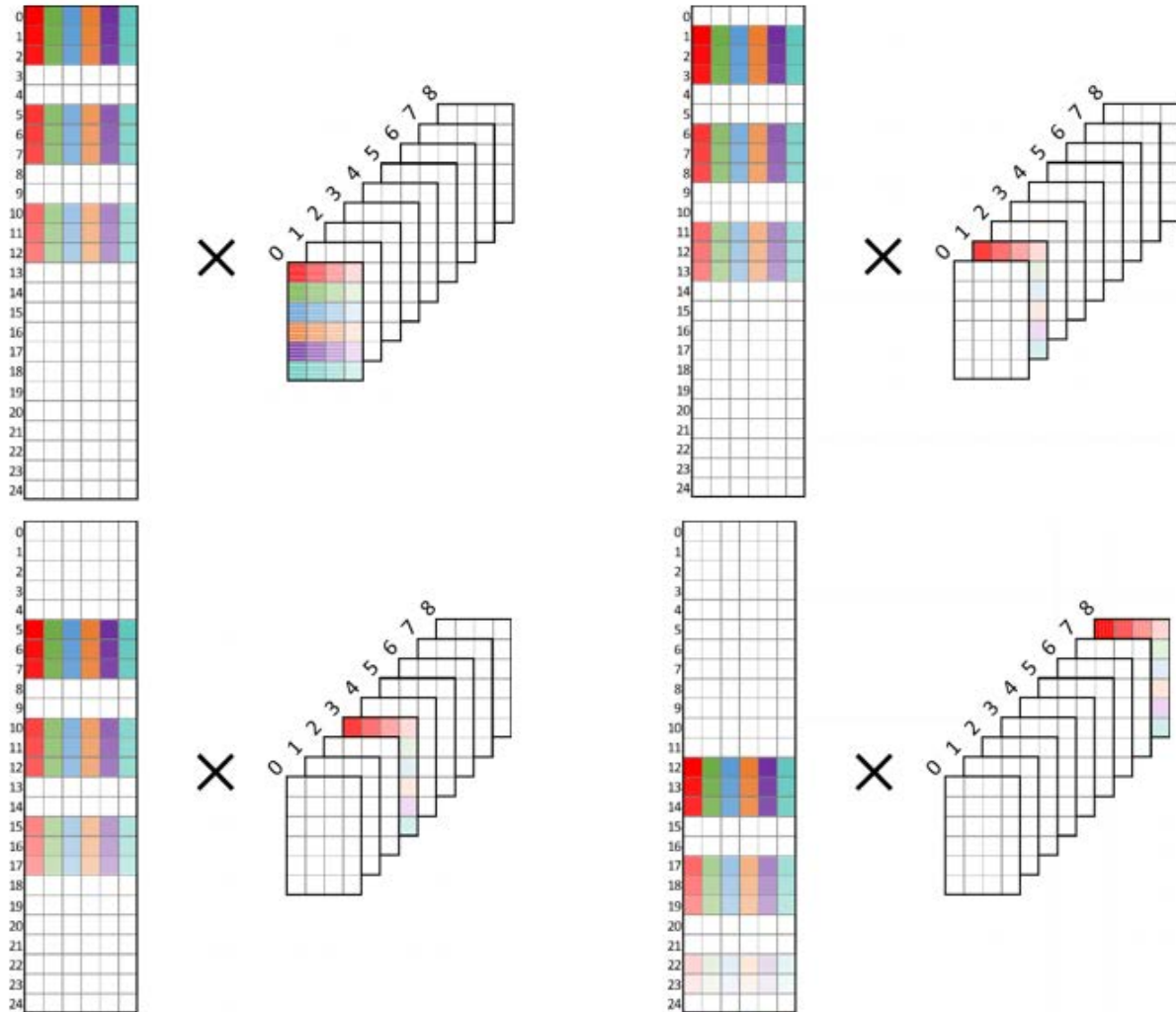

Figure 20-8. Matrix-Like Multiplications Part of a Convolution

20.5.5.6 Optimized Convolution Implementation

Replace the common defines in Example 20-3 with the following:

Example 20-13. Common Defines for Convolution

```
#define H ...           // The height of the activation frame
#define W ...           // The width of the activation frame
#define MA (H*W)       // The M dimension (rows) of the A matrix
#define K ...          // Number of activation channels
#define N ...          // Number of output channels
#define KH ...         // The height of the weights kernel
#define KW ...         // The width of the weights kernel
#define SH ...         // The vertical stride of the convolution
#define SW ...         // The horizontal stride of the convolution
#define M_ACC ...      // Number of C accumulators spanning the M dimension
#define N_ACC ...      // Number of C accumulators spanning the N dimension
#define TILE_M ...     // Number of rows in an A or C tile
#define TILE_K ...     // Number of columns in an A tile or rows in a B tile
#define TILE_N ...     // Number of columns in a B or C tile

#define HC ((H-KH)/SH+1) // The height of the output frame
#define WC ((W-KW)/SW+1) // The width of the output frame
#define MC (HC*WC)      // The M dimension (rows) of the C matrix

typedef ... type_t;     // The type of the data being operated on
typedef... res_type_t; // The data type of the result

#define KPACK (4/sizeof(type_t)) // Vertical K packing into Dword

type_t A_mem[H][W][K]; // A matrix (equivalent to A_mem[H*W][K])
type_t B_mem[KH][KW][K/KPACK][N][KPACK]; // B matrices
res_type_t C_mem[MC][N]; // C matrix

template<size_t rows, size_t cols> class tile;

template<class T> void tilezero (T& t);
template<class T> void tileload (T& t, void* src, size_t stride);
template<class T> void tilestore(T& t, void* dst, size_t stride);
template<class TC, class TA, class TB> void tdp(TC& tC, TA& tA, TB& tB);

int mc_to_ha(int mc) {return mc / HC * SH;} // C matrix M -> A tensor h coord
int mc_to_wa(int mc) {return mc % HC * SW;} // C matrix M -> A tensor w coord
```

Replace the implementation in Example 20-8 with the following:

Example 20-14. Optimized direct convolution implementation

```

1 for (int n = 0; n < N; n += N_ACC*TILE_N) {
2   for (int m = 0; m < MC; m += M_ACC*TILE_M) {
3     tile<TILE_M, TILE_N*sizeof(res_type_t)> tC[M_ACC][N_ACC];
4     tile<TILE_M, TILE_K*sizeof(type_t)> tA[M_ACC];
5     tile<TILE_K/KPACK, TILE_N*KPACK> tB;
6
7     for (int n_acc = 0; n_acc < N_ACC; ++n_acc)
8       for (int m_acc = 0; m_acc < M_ACC; ++m_acc)
9         tilezero(tC[m_acc][n_acc]);
10
11    for (int k = 0; k < K; k += TILE_K) {
12      for (int kh = 0; kh < KH; ++kh) {
13        for (int kw = 0; kw < KW; ++kw) {
14          for (int n_acc = 0; n_acc < N_ACC; ++n_acc) {
15            int nc = n + n_acc*TILE_N;
16            tileload(tB, B_mem[kh][kw][k/KPACK][nc], N*sizeof(type_t)*KPACK);
17            for (int m_acc = 0; m_acc < M_ACC; ++m_acc) {
18              int mc = m + m_acc*TILE_M;
19              if (n_acc == 0) {
20                int ha = mc_to_ha(mc)+kh, wa = mc_to_wa(mc)+kw;
21                tileload(tA[m_acc], &A_mem[ha][wa][k], K*SW*sizeof(type_t));
22              }
23              tdp(tC[m_acc][n_acc], tA[m_acc], tB);
24              if (k + kh + kw == K - TILE_K + KH + KW - 2)
25                tilestore(tC[m_acc][n_acc], &C_mem[mc][nc], N*sizeof(res_type_t));
26            }
27          }
28        }
29      }
30    }
31  }
32 }

```

The divergences highlighted in yellow in Example 20-8 include:

- The loop over M-dimension (line 2) references the M-dimension of the C-matrix (since the M-dimensions of A and C no longer have to be the same). To get the corresponding A-matrix m index from a C-matrix m index, one must employ the conversion functions `mc_to_ha()` and `mc_to_wa()` (line 20).
- There are additional loops over the weights kernel dimensions KH and KW (lines 12–13), which define the B-matrix to be used (line 16), enter into the condition for accumulator tile storing (line 24) and computation of A-matrix coordinates (line 20).
- The stride of the A tile load must account for the convolutional horizontal stride (line 21).

Note that care should be taken to define `TILE_M*M_ACC` in such a way that it cleanly divides `WC` (the width of the output frame), i.e., `WC%(TILE_M*M_ACC)==0`. Otherwise, some tiles will end up loading data that should not be multiplied by the corresponding weight element (see Figure 20-8). Possible mitigations of this issue:

- An `M_ACC` loop with a dynamic upper limit depending on the current position in A.

- Use different sized A tiles (and correspondingly C tiles) depending on the current position in A (if there are enough free tiles, performing TileConfig during the convolution is highly discouraged).
- Define TILE_M without consideration for WC and remove/disregard the “junk” data from the results at the post-processing stage (code not shown). Care should be taken in this case concerning the advancement of the m index (line 2) since the current assumption is that every row of every tile is valid (corresponds to a row in the C matrix). If “junk” data is loaded, this is no longer the case: a C-tile will have less than TILE_M rows of C.

Location of the KH, KW Loops

As shown in Example 20-5, it is ill-advised to put the loop over the K-dimension inside an inner M_ACC or N_ACC loop. The same considerations hold in the case of the kh,kw loops. While there is no functional obstacle precluding the positioning of the kh,kw loops further up (before lines 12-13), it is recommended to keep them under the K loop and above the M_ACC, N_ACC loops because, during the traversal of kh,kw with the same k value, the TileLoad of A-data (line 21) will have much overlap with A-data loaded for previous values of kh,kw (with the same k value). This data will likely reside in the lowest-level cache. Moving the kh,kw loops upward will reduce that likelihood.

20.6 CACHE BLOCKING

Data movement costs vary greatly depending on where the data lies in the cache hierarchy. When the matrices involved in a GEMM or convolution are larger than the available cache, computations must proceed in such a manner as to optimize data reuse from the cache. Here a simple cache-blocking scheme is implemented to simultaneously process partial blocks of the A, B, and C matrices.

20.6.1 OPTIMIZED CONVOLUTION IMPLEMENTATION WITH CACHE BLOCKING

In the following example, the focus is on implementing cache blocking for the optimized convolution implementation described in the Optimized Convolution Implementation <XREF> section. However, note that similar changes can also be made to the optimized GEMM implementation. Alternatively, the GEMM implementation can be derived as a special case of convolution with KH=KW=1 and SH=SW=1.

In addition to the common defines in Example 20-13, add the following:

Example 20-15. Additional Defines for Convolution with Cache Blocking

```
#define MC_CACHE ...           // Extent of cache block along the M dimension of the C matrix
#define K_CACHE ...           // Extent of cache block along the K dimension
#define N_CACHE ...           // Extent of cache block along the N dimension
typedef ... acc_type_t;       // The accumulation data type (either int32 or float)
acc_type_t aC_mem[M_ACC][N_ACC][TILE_M][TILE_N]; // Accumulator buffers of C
```

Replace the implementation in Example 20-14 with the following example. The deviance from Example 20-14 is highlighted.

Example 20-16. Optimized Convolution Implementation with Cache Blocking

```

1 for (int nb = 0; nb < N; nb += N_CACHE) {
2   for (int mb = 0; mb < MC; mb += MC_CACHE) {
3     for (int kb = 0; kb < K; kb += K_CACHE) {
4       for (int n = nb; n < nb + N_CACHE; n += N_ACC*TILE_N) {
5         for (int m = mb; m < mb + MC_CACHE; m += M_ACC*TILE_M) {
6           tile<TILE_M, TILE_N*sizeof(res_type_t)> tC[M_ACC][N_ACC];
7           tile<TILE_M, TILE_K*sizeof(type_t)> tA[M_ACC];
8           tile<TILE_K/KPACK, TILE_N*KPACK> tB;
9
10          for (int n_acc = 0; n_acc < N_ACC; ++n_acc)
11            for (int m_acc = 0; m_acc < M_ACC; ++m_acc)
12              if (kb == 0)
13                tilezero(tC[m_acc][n_acc]);
14              else {
15                int m_aC = (m - mb) / TILE_M + m_acc;
16                int n_aC = (n - nb) / TILE_N + n_acc;
17                tileload(tC[m_acc][n_acc], &aC_mem[m_aC][n_aC],
18                  TILE_N*sizeof(acc_type_t));
19              }
20
21          for (int k = kb; k < kb + K_CACHE; k += TILE_K) {
22            for (int kh = 0; kh < KH; ++kh) {
23              for (int kw = 0; kw < KW; ++kw) {
24                for (int n_acc = 0; n_acc < N_ACC; ++n_acc) {
25                  int nc = n + n_acc*TILE_N;
26                  tileload(tB, B_mem[kh][kw][k/KPACK][nc], N*sizeof(type_t)*KPACK);
27                  for (int m_acc = 0; m_acc < M_ACC; ++m_acc) {
28                    int mc = m + m_acc*TILE_M;
29                    if (n_acc == 0) {
30                      int ha = mc_to_ha(mc)+kh, wa = mc_to_wa(mc)+kw;
31                      tileload(tA[m_acc], &A_mem[ha][wa][k], K*SW*sizeof(type_t));
32                    }
33                    tdp(tC[m_acc][n_acc], tA[m_acc], tB);
34                    if (k + kh + kw == K - TILE_K + KH + KW - 2)
35                      tilestore(tC[m_acc][n_acc], &C_mem[mc][nc],
36                        N*sizeof(res_type_t));
37                    else if (k + kh + kw == kb + K_CACHE - TILE_K + KH + KW - 2) {
38                      int m_aC = (m - mb) / TILE_M + m_acc;
39                      int n_aC = (n - nb) / TILE_N + n_acc;
40                      tilestore(tC[m_acc][n_acc], &aC_mem[m_aC][n_aC],
41                        TILE_N*sizeof(acc_type_t));
42                    }
43                  }
44                }
45              }
46            }
47          }
48        }
49      }
50    }
51  }
52 }

```

The loops over the N, MC, and K dimensions are replaced by loops over cache blocks of N, MC, and K.

Additional loops over the entire N, MC, and K-dimensions are added at the outermost level. These loops have a step size equal to the cache blocks of N, MC, and K.

In the case of cache blocking along the K-dimension, additional calls to `TileLoad` and `TileStore` are required to load and store intermediate accumulation results. Note that this adds additional memory traffic, especially for `int8` output data types (as Accumulation data type is either `int32_t` or `float`). For this reason, it is generally not advisable to block along the K dimension.

For simplicity, assume the following relationships:

- N is an integer multiple of `N_CACHE`: an integer multiple of `N_ACC*TILE_N`.
- MC is an integer multiple of `MC_CACHE`: an integer multiple of `M_ACC*TILE_M`. As before, the condition `WC%(TILE_M*M_ACC)==0` still holds.
- K is an integer multiple of `K_CACHE`: an integer multiple of `TILE_K`.

Define the following set of operations as the compute kernel of the optimized convolution implementation. First, initialize the accumulation tiles to zero (line 13) for an `M_ACC*TILE_M` x `N_ACC*TILE_N` chunk of the C-matrix. Next, for each of the `KH*KW` B-matrices, the matrix multiplication of the corresponding `M_ACC*TILE_M` x `K` chunk of the A-matrix by a `K` x `N_ACC*TILE_N` chunk of the B-matrix is performed, each time accumulating to the same set of accumulation tiles (lines 18–30). Finally, the results are stored in the C-matrix (line 32).

Continue with the computation **of a full cache block** of C-matrix, ignoring any blocking along the K-dimension. First, the kernel is performed for the first chunks of the A, B, and C cache blocks. Next, the chunks of A and C advance along the M dimension, and the kernel is repeated with the same chunk set of the B-matrices. The above step is repeated until the last chunks of A and C in the current cache block have been accessed. Next, the chunks of B and C are advanced along the N-dimension by `N_ACC*TILE_N` and the chunk of A returns to the beginning of its cache block.

Observe the following from the above description of the computation of a **full cache** block of the C-matrix:

- For each kernel iteration, it is better if the current chunk of matrix A (roughly `KH*M_ACC*TILE_M*K*sizeof(type_t)`) fits into the DCU. This allows for maximal data reuse between the partially overlapping regions of A that need to be accessed by the different B matrices.
- Advancing from one chunk of matrix A to the next, it is better if the current chunk set of the B matrices (in total, `KH*KW*K*N_ACC*TILE_N*sizeof(type_t)`) fits into the DCU.
- Advancing from one chunk set of the B matrices to the next, it is better if the current cache block of matrix A fits into the MLC.
- Advancing from one cache block of matrix A to the next, it is better if the current cache block of the B matrices (in total, `KH*KW*K*N_CACHE*sizeof(type_t)`) fits into the MLC.

From these observations, a general cache blocking strategy is choosing `MC_CACHE` and `N_CACHE` to be as large as possible while keeping the A, B, and C cache blocks in the MLC.

Intel AMX-Specific Considerations

A specific feature of AMX-accelerated kernels to keep in mind when applying the previous cache-blocking recommendations is any post-processing of results from the AMX unit (e.g., adding bias, dequantizing, converting between data types) must occur by way of vector registers. Thus, a buffer is needed to store results from the accumulation tiles and load them into vector registers for post-processing. Note that if `acc_type_t` is the same as `res_type_t`, the C matrix itself can be used to store intermediate results. However, the buffer is small (at most 4KB for the accumulation strategies described in `vSection`) and easily fits into the DCU. While it should still be considered when determining the optimal cache block partitioning, it is unlikely to influence kernel performance strongly.

20.7 MINI-BATCHING IN LARGE BATCH INFERENCE

Layers have different sizes and shapes, which require different cache and memory-blocking strategies. There are layers with a small spatial dimension (M) and relatively larger shared dimension (K) and SIMD dimension (N). In such layers, the weights are significantly larger than the inputs. Therefore, most of the load operations are weights matrix loads whose cost is high when the weights reside in memory or the last level cache.

Running a large batch allows employing an optimization that amortizes the cost of loading the weight matrix. The idea is to use the same weights for multiple inputs, e.g., execute the same layer with multiple images. This optimization is highly applicable in CNNs where the inputs of the first layers are large while the weights are relatively small but end with small input images and large weight matrices. Optimal execution of the topology starts in the instance or image affinity, where a single input goes through one layer after another before the next input is retrieved. At some point, the topology execution switches to layer affinity, where the same layer processes several inputs (mini-batch) before moving forward to the next layer.

For example, in ResNet-50, the conv-1 to conv-4 layers have relatively large IFMs and smaller weight matrices. However, many weight matrices are larger than MLC size (mid-level cache) in the conv-5 layers. The switchover point from image affinity to layer affinity on a 4th Generation Intel® Xeon® Processor microarchitecture is the first layer of conv-5.

The diagram below illustrates six layers with four instances per thread (mini-batch of four). Boxes with identical colors identify the same layers in each column. Arrows flowing downward through each column's layers represent the data flow of a particular instance. Translucent red arrows identify the execution order of layers with corresponding instances. The first four layers of the diagram have instance (aka image) affinity, and the last two have layer affinity.

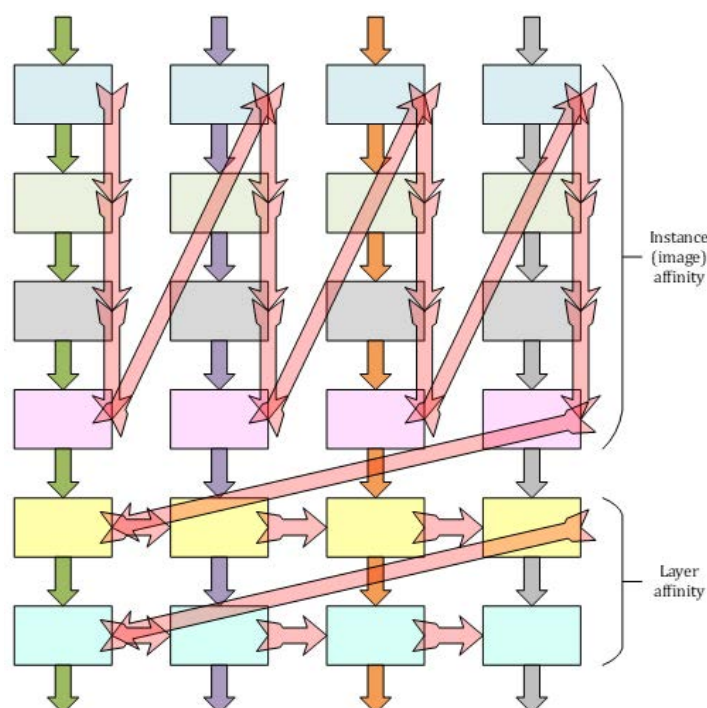

Figure 20-9. Batching Execution Using Six Layers with Four Instances Per Thread

On Resnet-50, this optimization can yield a 17% performance gain.

20.8 NON-TEMPORAL TILE LOADS

When a regular tile load is issued, the data for the tile are placed in L2, L1, and then in the tile register (DRAM/L3->L2->L1->tile register), as with any other register load. This has the well-known benefit of reduced data read latency due to data proximity when recently accessed data are reaccessed after a short time. However, indiscriminate application of this approach might sometimes prove detrimental.

Consider the code in Example 20-4, referring to the unoptimized, unblocked implementation for simplicity. The five loops in the code listing alongside the total input (A) matrix data and weights (B) matrix data accessed at each loop level is shown in the following table. The original row in the code listing is provided for convenience:

Table 20-3. Five loops in the Example 20-4 Code Listing

Row	Var	Variable Range	A Data Size	B Data Size
1	n	[0:N:N_ACC×TILE_N]	M×K	K×N
2	m	[0:M:M_ACC×TILE_M]	M×K	K×N_ACC×TILE_N
8	k	[0:K:TILE_K]	M_ACC×TILE_M×K	
9	n acc	[0:N_ACC:1]	M_ACC×TILE_M×TILE_K	TILE_K×N_ACC×TILE_N
12	m ac	[0:M_ACC:1]		

Priority Inversion Scenarios with Temporal Loads

For the following discussion, assume:

- The data type is int8 (i.e., each element in the table above takes 1 byte).
- TILE_M=16, TILE_K=64, TILE_N=16 (i.e., all tiles are of size 1kB).
- L1 cache size is 32kB.
- M_AC=N_ACC=2.

Scenario 1:

Consider the following scenario, including M=256, K=1024, and N=256. The corresponding table of accessed data sizes is given below.

Table 20-4. Accessed Data Sizes

Row	Var	Variable Range	A Data Size	B Data Size
1	n	[0:N:N_ACC×TILE_N]	256kB	256kB
2	m	[0:M:M_ACC×TILE_M]		32kB
8	k	[0:K:TILE_K]	32kB	
9	n acc	[0:N_ACC:1]	32kB	2kB
12	m ac	[0:M_ACC:1]		

At the k loop level, the combined sizes of A and B accessed data will overflow the L1 cache by a factor of two. Proceeding to the m-level since m is progressing, new A-data are constantly read (a total of 256kB-32kB=224kB new A data), while the same 32kB of B data are being accessed repeatedly. Thus, a priority inversion occurs: new A-data placed in the L1 cache repeatedly are accessed only once. They evict the 32kB of B data that are accessed eight times. Placement of A data in the L1 cache is not beneficial: the

next time the same data are accessed will be in the n loop after 256kB (x8 L1 cache size) of A data has been read. Additionally, it is detrimental because it causes repeated eviction of 32kB of B data that could have been read from the L1 cache eight times.

Scenario 2:

Consider the following scenario, including $M=32$, $K=1024$, and $N=256$:

Table 20-5. Accessed Data Sizes

Row	Var	Variable Range	A Data Size	B Data Size
1	n	$[0:N:N_ACC \times TILE_N]$	32kB	256kB
2	m	$[0:M:M_ACC \times TILE_M]$		32kB
8	k	$[0:K:TILE_K]$		32kB
9	$n\ acc$	$[0:N_ACC:1]$	2kB	2kB
12	$m\ ac$	$[0:M_ACC:1]$		

Here, the M-dimension is covered in the m_acc loop, and the loop over m is redundant. The priority inversion is: as n advances, new B-data (accessed only once) repeatedly evict 32kB of A-data that could have been read (8 times) from the L1 cache had it not been pushed out by B-data.

These two basic scenarios can be readily extended to the blocked code in Example 20-16:

Table 20-6.

Row	Var	Variable Range	A Data Size	B Data Size
1	nb	$[0:N:N_CACHE]$	$M \times K$	
2	mb	$[0:MC:MC_CACHE]$	$M \times K$	
3	kb	$[0:K:K_CACHE]$	$MC_CACHE \times K$	
4	n	$[nb:nb+N_CACHE:N_ACC \times TILE_N]$	$MC_CACHE \times K_CACHE$	$K_CACHE \times KH \times KW \times N_ACC \times TILE_N$
5	m	$[mb:mb+MC_CACHE:M_ACC \times TILE_M]$		
18	k	$[kb:kb+K_CACHE:TILE_K]$		
19	kh	$[0:KH:1]$	$/*/*$	$TILE_K \times KH \times KW \times N_ACC \times TILE_N$
20	kw	$[0:KW:1]$	$M_ACC \times TILE_M \times TILE_K$	
21	$n\ acc$	$[0:N_ACC:1]$		$TILE_K \times N_ACC \times TILE_N$
24	$m\ ac$	$[0:M_ACC:1]$		

****Note:** due to the nature of convolution, the loops over kh , kw reuse most of the A-data.

The innermost loops m_acc , n_acc , kh , kw will access at most M_ACC kB of A data and $KH \times KW \times N_ACC$ kB of B-data, which, in some cases (e.g., $KH=KW=3$, $N_ACC=4$) might already overflow the L1 cache size. Thus, several opportunities for priority inversions exist in this more complex loop structure, depending on the parameters in the table above:

- B-data evicting reusable A-data at the kh, kw loops level.
- A data evicting reusable B-data at the m loop level.
- B data evicting reusable A-data at the n loop level.

- A data evicting reusable B-data at the mb loop level.
- B-data evicting reusable A-data at the nb loop level.

Solution to Priority Inversions: Non-temporal Loads

Intel AMX architecture introduces a way to load tile registers bypassing the L1 cache via non-temporal tile loads (TILELOADDT1). This allows the user to deal with priority inversions such as those described above by loading the large, non-reusable data chunk with non-temporal loads. Thus, the larger chunk is prevented from evicting the smaller, frequently used data chunk. In Scenario 1 above, the user would load the A-tiles with non-temporal loads while loading B-tiles with temporal loads, thus ensuring that the B-tile loads at the m loop level will all come from the L1 cache. In Scenario 2 above, the user would load the B-tiles with non-temporal loads while loading A-tiles with temporal loads, thus ensuring that the A-tile loads at the n loop level will all come from the SL1 cache.

20.9 USING LARGE TILES IN SMALL CONVOLUTIONS TO MAXIMIZE DATA REUSE

A convolution with a small-sized input frame can make the Intel AMX computation inefficient.

Consider the following example: a 7×7 input frame, with padding of 1 (size including padding is 9×9), convolved with a 3×3 filter to produce a 7×7 output frame.

Figure 20-10 highlights the elements participating in the convolution interacting with the $kh=0,0$ weight element.

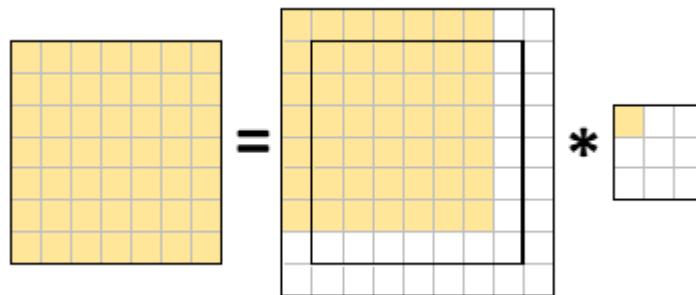

Figure 20-10. An Example of a Convolution
Elements interacting with weight element $kh,kw=0,0$ are highlighted.

Thus, the highlighted elements of the input frame are the only ones that should be loaded into A tiles when processing weight element $kh,kw=0,0$. The white elements of the input frame should be ignored. This requires the number of tile rows to be set at seven, utilizing less than half of the A tile, which in turn reduces B (weights) data reuse by a factor of two. This is because each A-tile is now half the size, and seven tiles are required to cover the spatial dimension. Because there are not seven tiles, B tiles must be loaded twice as many times, potentially leading to significant performance degradation, depending on the size of the weights. This is usually inversely proportional to the spatial size of the input frame).

Figure 20-11 shows three A tiles with sixteen rows and one tile with seven rows to cover the entire spatial dimension of the convolution.

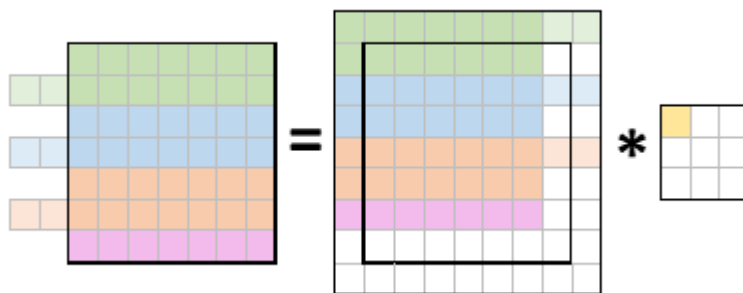

Figure 20-11. An Example of a Convolution with Large Tiles.
Elements going into each tile are highlighted differently.

Each tile is highlighted differently. The green, blue, and orange tiles now load those two “extra” elements previously ignored. Those elements will waste compute resources and take up two rows in the accumulator tiles. It is up to the user to ignore those rows in subsequent computations (e.g., int8-quantization, RELU, etc.), complicating the implementation. The potential benefit of increased B data reuse could be dramatic, however.

20.10 HANDLING INCONVENIENTLY SIZED ACTIVATIONS

Occasionally activations’ spatial dimensions might be ill-suited for efficient tiling with tiles altogether. Consider a GEMM with activations’ $M=100$. This poses a challenge: while the M dimension can be neatly tiled by ten tiles, each tile with ten rows, this approach is inefficient since a larger M dimension of 112 requires only seven tiles with sixteen rows. This means that the data reuse for $M=100$ is 30% worse than for $M=112$.

The following solutions will be useful:

1. Define two types of A- and C-tiles – tiles with 16 rows and one tile with four. Use tiles of the first type for $M=0..9$ and the second type tile for $M=96..99$.
2. Allocate extra space in A and C buffers, as if $M=112$, and use tiles with 16 rows exclusively. The extra space need not be zeroed out or otherwise prepared in any way. In this case the last (seventh) tile will load four meaningful rows ($M=96..99$) and twelve “garbage” rows ($M=100..111$). At the output, tile C will have four meaningful rows ($M=96..99$) and twelve “garbage” rows ($M=100..111$) which the user can then ignore.

The first solution does not require tampering with the A and C buffers, computes 100 tile rows and produces a clean result, but it requires additional A and C tiles which are unused throughout the computation except for the very end. Since there are only 8 tiles available, this requirement can be costly, and end up **reducing** the data reuse (e.g., you want to use a 2D accumulator array; you would need 3x2 C tiles, 2 A tiles and 2 B tiles = 10 tiles). The second solution avoids this requirement by complicating buffer handling, and by paying with compute and extra loads and stores (it loads, computes, and stores 112 tile rows).

20.11 POST-CONVOLUTION OPTIMIZATIONS

Most AMX-friendly applications are from the Deep Learning domain, where the data flows through multiple layers. It is often necessary to process the convolution output before passing it as an input to the next layer (processing operations depend on a specific application). This stage is called **post-convolution**.

20.11.1 POST-CONVOLUTION FUSION

As with Intel AVX-512 code, a critical optimization is the “fusion” of post-convolutional operations to the convolutional data they operate upon. Fusion reduces the memory hierarchy thrashing. Additionally, fusing the quantization step gains x2 (for bfloat16 data type) or x4 (for int8 data type) compute bandwidth and reduces memory bandwidth by x2 or x4, respectively.

Consider the code in Example 20-8. Lines 7-24 contain the entire GEMM operation for any M, N coordinate in the output. Thus, the optimal location to post-process the data computed in lines 7-24 is right before line 24 while it is still in the low-level cache.

Below (highlighted in green) is a fully unrolled example of the code in lines 7-24, for int8 GEMM with $K=192$, $N_ACC=M_ACC=2$, $TILE_M=2$, $TILE_K=64$, $TILE_N=16$. The convolution code is fused with post-convolution code (highlighted in blue) that quantizes the output and ReLU. To keep the post-convolution code in the example short, an unrealistically low value of $TILE_M=2$ was chosen.

Example 20-17. Optimized Convolution Implementation with Cache Blocking

```

/*1 of 2*/
1  #define TILE_N_B          (N)
2  #define A_OFFSET(m,k)    ((m)*K*TILE_M + (k)*TILE_K)
3  #define B_OFFSET(k,n)    ((k)*N*TILE_N*4 + (n)*TILE_N*4)
4  #define C_OFFSET(m,n)    ((m)*N*TILE_M + (n)*TILE_N)
5  #define C_TMP_OFFSET(m,n) ((m)*N*TILE_M*4 + (n)*TILE_N*4)
6  #define Q_OFFSET(n)      ((n)*TILE_N*4)
7  #define BIAS_OFFSET(n)   ((n)*TILE_N*4 + N*4)
8
9  static const tileconfig_t tc = {
10     1,                    // Palette ID
11     0,                    // Start row
12     0, 0, 0, 0, 0, 0, 0, 0, 0, 0, 0, 0, 0, 0, // Reserved - must be 0
13     64, 64, 64, 64, 64, 64, 64, 0, 0, 0, 0, 0, 0, 0, 0, // Cols for 7 tiles used
14     2, 2, 2, 2, 2, 16, 16, 0, 0, 0, 0, 0, 0, 0, 0, // Rows for tiles used: 2 for A, C,
15                                                    // 16 for B
16 };
17
18 ldtilecfg tc              // Load tile config
19 mov     r12, 192          // A stride
20 mov     r13, 128          // B, C_TMP stride
21 tileload tmm5, [r9 + r13*1 + B_OFFSET(0,0)] // Load B [k,n] = [0,0]
22 tileload tmm4, [r8 + r12*1 + A_OFFSET(0,0)] // Load A [m,k] = [0,0]
23 tilezero tmm0            // Zero acc [m,n] = [0,0]
24 tdpbusd tmm0, tmm4, tmm5
25 tileload tmm6, [r9 + r13*1 + B_OFFSET(0,1)] // Load B [k,n] = [0,1]
26 tilezero tmm2            // Zero acc [m,n] = [0,1]
27 tdpbusd tmm2, tmm4, tmm6
28 tileload tmm4, [r8 + r12*1 + A_OFFSET(1,0)] // Load A [m,k] = [1,0]
29 tilezero tmm1            // Zero acc [m,n] = [1,0]
30 tdpbusd tmm1, tmm4, tmm5
31 tilezero tmm3            // Zero acc [m,n] = [1,1]
32 tdpbusd tmm3, tmm4, tmm6
33 tileload tmm5, [r9 + r13*1 + B_OFFSET(1,0)] // Load B [k,n] = [1,0]
34 tileload tmm4, [r8 + r12*1 + A_OFFSET(0,1)] // Load A [m,k] = [0,1]
35 tdpbusd tmm0, tmm4, tmm5
36 tileload tmm6, [r9 + r13*1 + B_OFFSET(1,1)] // Load B [k,n] = [1,1]
37 tdpbusd tmm2, tmm4, tmm6
38 tileload tmm4, [r8 + r12*1 + A_OFFSET(1,1)] // Load A [m,k] = [1,1]
39 tdpbusd tmm1, tmm4, tmm5
40 tdpbusd tmm3, tmm4, tmm6
41 tileload tmm5, [r9 + r13*1 + B_OFFSET(2,0)] // Load B [k,n] = [2,0]
42 tileload tmm4, [r8 + r12*1 + A_OFFSET(0,2)] // Load A [m,k] = [0,2]
43 tdpbusd tmm0, tmm4, tmm5
44 tilestore [r11 + r13*1 + C_TMP_OFFSET(0,0)], tmm0 // Store C tmp [m,n] = [0,0]
45 tileload tmm6, [r9 + r13*1 + B_OFFSET(2,1)] // Load B [k,n] = [2,1]

```

```

/*2 of 2*/
46 tdpbusd      tmm2, tmm4, tmm6
47 tilestored   [r11 + r13*1 + C_TMP_OFFSET(0,1)], tmm2      // Store C tmp [m,n] = [0,1]
48 tileloadd    tmm4, [r8 + r12*1 + A_OFFSET(1,2)]          // Load A [m,k] = [1,2]
49 tdpbusd      tmm1, tmm4, tmm5
50 tilestored   [r11 + r13*1 + C_TMP_OFFSET(1,0)], tmm1      // Store C tmp [m,n] = [1,0]
51 tdpbusd      tmm3, tmm4, tmm6
52 tilestored   [r11 + r13*1 + C_TMP_OFFSET(1,1)], tmm3      // Store C tmp [m,n] = [1,1]
53
54 vcvtdq2ps    zmm0, [r11 + C_TMP_OFFSET(0,0) + 0*TILE_N_B] // int32 -> float
55 vmovups      zmm1, [r14 + Q_OFFSET(0)]                  // q-factors for N=0
56 vmovups      zmm2, [r14 + BIAS_OFFSET(0)]              // biases for N=0
57 vfmadd213ps  zmm0, zmm1, zmm2                          // zmm0 = zmm0 * q + b
58 vcvtps2dq    zmm0, zmm0                                // float -> int32
59 vpxord       zmm3, zmm3, zmm3                          // Prepare zero ZMM
60 vpmaxsd      zmm0, zmm0, zmm3                          // RELU (int32)
61 vpmovusdb    [r10 + C_OFFSET(0,0) + 0*TILE_N_B], zmm0   // uint32 -> uint8
62 vcvtdq2ps    zmm4, [r11 + C_TMP_OFFSET(0,0) + 4*TILE_N_B] // int32 -> float
63 vfmadd213ps  zmm4, zmm1, zmm2                          // zmm4 = zmm4 * q + b
64 vcvtps2dq    zmm4, zmm4                                // float -> int32
65 vpmaxsd      zmm4, zmm4, zmm3                          // RELU (int32)
66 vpmovusdb    [r10 + C_OFFSET(0,0) + 1*TILE_N_B], zmm4   // uint32 -> uint8
67 vcvtdq2ps    zmm5, [r11 + C_TMP_OFFSET(1,0) + 0*TILE_N_B] // int32 -> float
68 vfmadd213ps  zmm5, zmm1, zmm2                          // zmm5 = zmm5 * q + b
69 vcvtps2dq    zmm5, zmm5                                // float -> int32
70 vpmaxsd      zmm5, zmm5, zmm3                          // RELU (int32)
71 vpmovusdb    [r10 + C_OFFSET(1,0) + 0*TILE_N_B], zmm5   // uint32 -> uint8
72 vcvtdq2ps    zmm6, [r11 + C_TMP_OFFSET(1,0) + 4*TILE_N_B] // int32 -> float
73 vfmadd213ps  zmm6, zmm1, zmm2                          // zmm6 = zmm6 * q + b
74 vcvtps2dq    zmm6, zmm6                                // float -> int32
75 vpmaxsd      zmm6, zmm6, zmm3                          // RELU (int32)
76 vpmovusdb    [r10 + C_OFFSET(1,0) + 1*TILE_N_B], zmm6   // uint32 -> uint8
77 vcvtdq2ps    zmm7, [r11 + C_TMP_OFFSET(0,1) + 0*TILE_N_B] // int32 -> float
78 vmovups      zmm8, [r14 + Q_OFFSET(1)]                  // q-factors for N=1
79 vmovups      zmm9, [r14 + BIAS_OFFSET(1)]              // biases for N=1
80 vfmadd213ps  zmm7, zmm8, zmm9                          // zmm7 = zmm7 * q + b
81 vcvtps2dq    zmm7, zmm7                                // float -> int32
82 vpmaxsd      zmm7, zmm7, zmm3                          // RELU (int32)
83 vpmovusdb    [r10 + C_OFFSET(0,1) + 0*TILE_N_B], zmm7   // uint32 -> uint8
84 vcvtdq2ps    zmm10, [r11 + C_TMP_OFFSET(0,1) + 4*TILE_N_B] // int32 -> float
85 vfmadd213ps  zmm10, zmm8, zmm9                          // zmm10 = zmm10 * q + b
86 vcvtps2dq    zmm10, zmm10                              // float -> int32
87 vpmaxsd      zmm10, zmm10, zmm3                        // RELU (int32)
88 vpmovusdb    [r10 + C_OFFSET(0,1) + 1*TILE_N_B], zmm10   // uint32 -> uint8
89 vcvtdq2ps    zmm11, [r11 + C_TMP_OFFSET(1,1) + 0*TILE_N_B] // int32 -> float
90 vfmadd213ps  zmm11, zmm8, zmm9                          // zmm11 = zmm11 * q + b
91 vcvtps2dq    zmm11, zmm11                              // float -> int32
92 vpmaxsd      zmm11, zmm11, zmm3                        // RELU (int32)
93 vpmovusdb    [r10 + C_OFFSET(1,1) + 0*TILE_N_B], zmm11   // uint32 -> uint8
94 vcvtdq2ps    zmm12, [r11 + C_TMP_OFFSET(1,1) + 4*TILE_N_B] // int32 -> float
95 vfmadd213ps  zmm12, zmm8, zmm9                          // zmm12 = zmm12 * q + b
96 vcvtps2dq    zmm12, zmm12                              // float -> int32
97 vpmaxsd      zmm12, zmm12, zmm3                        // RELU (int32)
98 vpmovusdb    [r10 + C_OFFSET(1,1) + 1*TILE_N_B], zmm12   // uint32 -> uint8

```

In this example, an additional buffer, `temporary_C`, contains the convolutional results of `M_ACCxN_ACC` tiles. The results are stored at the end of the convolutional part and loaded during the post-convolutional part. A temporary buffer is required because the size of the post-processed data is four times smaller. Hence, the convolutional output cannot be written directly to the output buffer.

The GPRs `r8`, `r9`, `r10`, `r11`, and `r14` point to the current location in the `A`, `B`, `C`, `temporary_C`, and `q_bias` (which holds the quantization factors and biases) buffers, respectively.

The macros `A_OFFSET(m,k)`, `B_OFFSET(k,n)`, `C_OFFSET(m,n)`, `C_TMP_OFFSET(m,n)`, `Q_OFFSET(n)` and `BIAS_OFFSET(n)` receive as arguments `m,k,n` tile indices and return the offset of the data from `r8,r9,r10`, `r11`, and `r14`, respectively.

20.11.2 INTEL® AMX AND INTEL® AVX-512 INTERLEAVING (SW PIPELINING)

A modern CPU has multiple functional units that can execute different instructions simultaneously. For example, a load instruction and an arithmetic instruction can execute in parallel. A commonly used approach for maximizing the utilization of various resources in parallel is the out-of-order execution, where the CPU might alter the order of the instructions to achieve higher resource utilization.

Intel AMX compute instructions are prime candidates for optimization of this sort since they utilize resources very lightly (1/2 of the available ALU ports, 1/TILE_M of the time).

Theoretically, the post-convolutional code (blue) of one iteration could execute in parallel to the code in lines 3-25 (green, before the first `TileStore`) of the next iteration, where iteration is the execution of the code in Example 20-17. Unfortunately, this cannot be done automatically and efficiently by the CPU: since the convolution (green) and post-convolution (blue) parts of the code tend to be sizable; the CPU can only overlap small portions of them efficiently before it runs out of resources in the out-of-order machine. Thus, a manual (SW) solution is required.

As previously written, the blue code before the first `TileStore` can be run in parallel with the green code of the next iteration. This would overwrite `temporary_C` memory, which the post-convolution code reads from. To remove this dependency and maximize parallel execution, use double-buffering on `temporary_C`. `temporary_C` would thus contain two buffers, interchanged every iteration.

Below, the content deviates from the previous example by interleaving the convolutional code of the current iteration with the post-convolutional code of the previous iteration. `temporary_C` is double-buffered, with `r11` pointing to the buffer of the current iteration and `r12` pointing to the buffer of the previous iteration. They are exchanged at the end of the iteration.

Example 20-18. Example of a Short GEMM Fused and Pipelined with Quantization and ReLU

```

/*1 of 3*/
1  ldtilecfg      tc                // Load tile config
2  mov           r15, 192           // A stride
3  mov           r13, 128           // B, C_TMP stride
4  tileloadd     tmm5, [r9 + r13*1 + B_OFFSET(0,0)] // Load B [k,n] = [0,0]
5  tileloadd     tmm4, [r8 + r15*1 + A_OFFSET(0,0)] // Load A [m,k] = [0,0]
6  tilezero      tmm0              // Zero acc [m,n] = [0,0]
7  vcvtdq2ps    zmm0, [r12 + C_TMP_OFFSET(0,0) + 0*TILE_N_B] // int32 -> float
8  vmovups      zmm1, [r14 + Q_OFFSET(0)]           // q-factors for N=0
9  vmovups      zmm2, [r14 + BIAS_OFFSET(0)]        // biases for N=0
10 vfmadd213ps  zmm0, zmm1, zmm2                    // zmm0 = zmm0 * q + b
11 vcvtps2dq    zmm0, zmm0              // float -> int32
12 vpxord       zmm3, zmm3, zmm3          // Prepare zero ZMM
13 vpmaxsd     zmm0, zmm0, zmm3          // RELU (int32)
14 tdpbusd     tmm0, tmm4, tmm5

```

```

/*2 of 3*/
15 tileloadd      tmm6, [r9 + r13*1 + B_OFFSET(0,1)]      // Load B [k,n] = [0,1]
16 tilezero      tmm2                                  // Zero acc [m,n] = [0,1]
17 vpmovusdb     [r10 + C_OFFSET(0,0) + 0*TILE_N_B], zmm0 // uint32 -> uint8
18 vcvtdq2ps     zmm4, [r12 + C_TMP_OFFSET(0,0) + 4*TILE_N_B] // int32 -> float
19 vfmadd213ps   zmm4, zmm1, zmm2                      // zmm4 = zmm4 * q + b
20 tdpbusd       tmm2, tmm4, tmm6
21 tileloadd      tmm4, [r8 + r15*1 + A_OFFSET(1,0)]      // Load A [m,k] = [1,0]
22 tilezero      tmm1                                  // Zero acc [m,n] = [1,0]
23 vcvtps2dq     zmm4, zmm4                            // float -> int32
24 vpmaxsd       zmm4, zmm4, zmm3                      // RELU (int32)
25 vpmovusdb     [r10 + C_OFFSET(0,0) + 1*TILE_N_B], zmm4 // uint32 -> uint8
26 tdpbusd       tmm1, tmm4, tmm5
27 tilezero      tmm3                                  // Zero acc [m,n] = [1,1]
28 vcvtdq2ps     zmm5, [r12 + C_TMP_OFFSET(1,0) + 0*TILE_N_B] // int32 -> float
29 vfmadd213ps   zmm5, zmm1, zmm2                      // zmm5 = zmm5 * q + b
30 vcvtps2dq     zmm5, zmm5                            // float -> int32
31 vpmaxsd       zmm5, zmm5, zmm3                      // RELU (int32)
32 tdpbusd       tmm3, tmm4, tmm6
33 tileloadd      tmm5, [r9 + r13*1 + B_OFFSET(1,0)]      // Load B [k,n] = [1,0]
34 tileloadd      tmm4, [r8 + r15*1 + A_OFFSET(0,1)]      // Load A [m,k] = [0,1]
35 vpmovusdb     [r10 + C_OFFSET(1,0) + 0*TILE_N_B], zmm5 // uint32 -> uint8
36 vcvtdq2ps     zmm6, [r12 + C_TMP_OFFSET(1,0) + 4*TILE_N_B] // int32 -> float
37 vfmadd213ps   zmm6, zmm1, zmm2                      // zmm6 = zmm6 * q + b
38 tdpbusd       tmm0, tmm4, tmm5
39 tileloadd      tmm6, [r9 + r13*1 + B_OFFSET(1,1)]      // Load B [k,n] = [1,1]
40 vcvtps2dq     zmm6, zmm6                            // float -> int32
41 vpmaxsd       zmm6, zmm6, zmm3                      // RELU (int32)
42 vpmovusdb     [r10 + C_OFFSET(1,0) + 1*TILE_N_B], zmm6 // uint32 -> uint8
43 tdpbusd       tmm2, tmm4, tmm6
44 tileloadd      tmm4, [r8 + r15*1 + A_OFFSET(1,1)]      // Load A [m,k] = [1,1]
45 vcvtdq2ps     zmm7, [r12 + C_TMP_OFFSET(0,1) + 0*TILE_N_B] // int32 -> float
46 vmovups       zmm8, [r14 + Q_OFFSET(1)]              // q-factors for N=1
47 vmovups       zmm9, [r14 + BIAS_OFFSET(1)]           // biases for N=1
48 vfmadd213ps   zmm7, zmm8, zmm9                      // zmm7 = zmm7 * q + b
49 vcvtps2dq     zmm7, zmm7                            // float -> int32
50 vpmaxsd       zmm7, zmm7, zmm3                      // RELU (int32)
51 tdpbusd       tmm1, tmm4, tmm5
52 vpmovusdb     [r10 + C_OFFSET(0,1) + 0*TILE_N_B], zmm7 // uint32 -> uint8
53 vcvtdq2ps     zmm10, [r12 + C_TMP_OFFSET(0,1) + 4*TILE_N_B] // int32 -> float
54 vfmadd213ps   zmm10, zmm8, zmm9                     // zmm10 = zmm10 * q + b
55 tdpbusd       tmm3, tmm4, tmm6
56 tileloadd      tmm5, [r9 + r13*1 + B_OFFSET(2,0)]      // Load B [k,n] = [2,0]
57 tileloadd      tmm4, [r8 + r15*1 + A_OFFSET(0,2)]      // Load A [m,k] = [0,2]
58 vcvtps2dq     zmm10, zmm10                          // float -> int32
59 vpmaxsd       zmm10, zmm10, zmm3                    // RELU (int32)
60 vpmovusdb     [r10 + C_OFFSET(0,1) + 1*TILE_N_B], zmm10 // uint32 -> uint8
61 tdpbusd       tmm0, tmm4, tmm5
62 tilestored     [r11 + r13*1 + C_TMP_OFFSET(0,0)], tmm0 // Store C tmp [m,n] = [0,0]
63 tileloadd      tmm6, [r9 + r13*1 + B_OFFSET(2,1)]      // Load B [k,n] = [2,1]
64 vcvtdq2ps     zmm11, [r12 + C_TMP_OFFSET(1,1) + 0*TILE_N_B] // int32 -> float

```

```

/*3 of 3*/
65  vfmadd213ps  zmm11, zmm8 , zmm9           // zmm11 = zmm11 * q + b
66  vcvtps2dq   zmm11, zmm11           // float -> int32
67  vpmaxsd     zmm11, zmm11, zmm3     // RELU (int32)
68  tdpbusd     tmm2, tmm4, tmm6
69  tilestored  [r11 + r13*1 + C_TMP_OFFSET(0,1)], tmm2 // Store C tmp [m,n] = [0,1]
70  tileload    tmm4, [r8 + r15*1 + A_OFFSET(1,2)] // Load A [m,k] = [1,2]
71  vpmovusdb  [r10 + C_OFFSET(1,1) + 0*TILE_N_B], zmm11 // uint32 -> uint8
72  vcvtdq2ps  zmm12, [r12 + C_TMP_OFFSET(1,1) + 4*TILE_N_B] // int32 -> float
73  vfmadd213ps  zmm12, zmm8 , zmm9     // zmm12 = zmm12 * q + b
74  tdpbusd     tmm1, tmm4, tmm5
75  tilestored  [r11 + r13*1 + C_TMP_OFFSET(1,0)], tmm1 // Store C tmp [m,n] = [1,0]
76  vcvtps2dq   zmm12, zmm12           // float -> int32
77  vpmaxsd     zmm12, zmm12, zmm3     // RELU (int32)
78  vpmovusdb  [r10 + C_OFFSET(1,1) + 1*TILE_N_B], zmm12 // uint32 -> uint8
79  tdpbusd     tmm3, tmm4, tmm6
80  tilestored  [r11 + r13*1 + C_TMP_OFFSET(1,1)], tmm3 // Store C tmp [m,n] = [1,1]
81
82  xchg        r11, r12                // Swap buffers for current/next iter

```

Application of this algorithm with the parameters laid out in section Section , except for a larger TILE_M (N_ACC=M_ACC=2, TILE_M=16, TILE_K=64, TILE_N=16) on a [256x192] x [192x256] GEMM, yielded an 18.5% improvement in running time vs. the non-interleaved code described in Section 20.11.1.

20.11.3 AVOIDING THE H/W OVERHEAD OF PORT 5 FREQUENT OPEN/CLOSE OPERATIONS

When the processor executes Intel AMX compute instructions (TDP*) it normally closes port 5 (one of the two AVX-512 FMA ports) to conserve power. When the processor senses that there are no more Intel AMX compute instructions in the pipeline it opens port 5. This open/close operation stalls the pipeline for quite a few cycles. Up to 20% performance degradation may be observed when the AVX-512 instruction block colored in green below contains **100 to 300 AVX-512 instructions**.

We recommend to **add 1 or 2 TileZero instructions, in the middle of the green block, ~100 AVX-512 instructions apart** to ensure that port 5 is kept closed during blocks of up to 300 AVX-512 instructions. For longer blocks it is preferable not to insert TileZero since such longer blocks execute faster on 2 open FMA ports. The processor does not open port 5 for blocks that are shorter than 100 AVX-512 instructions, so no special handling is necessary here as well.

NOTE

The TileZero instruction is considered an Intel AMX compute instruction for that matter.



Figure 20-12. Please provide Figure Description

20.11.4 POST-CONV MULTIPLE OFM ACCUMULATION AND EFFICIENT DOWN-CONVERSION

An important question arises concerning fused post-convolution optimization. What is the optimal block of accumulators processed in a single post-convolution iteration? As a post-processing unit, it is convenient to consider the $M_ACC * N_ACC$ block of tiles accumulated in loops starting at lines 7-8 and 10-11 in Example 20-14 and Example 20-16, respectively. For simplicity, consider only multiples of these accumulation blocks. There is a trade-off between using smaller and larger post-convolution blocks:

Using small post-convolution blocks may have a negative impact by interrupting the convolution flow too often. Conversely, using big post-convolution blocks may also negatively impact by evicting part of the accumulated tiles out of DCU.

The optimal size, therefore, depends very much on the DL network topology and convolution-blocking parameters. Performance studies show that the number of iterations of $M_ACC * N_ACC$ blocks before proceeding to post-convolution iteration may vary from 1 to 7.

As AMX instructions generate a higher precision output (32-bit integers or 32-bit floats) from lower precision inputs (8-bit integers or 16-bit bfloats, respectively), there is a need to convert 32-bit outputs to 8- or 16-bit inputs to be fed to the next DL network layer.

If a single high-precision cache line (512-bit) is processed for conversion at a time, there will be four or two rounds of processing until a single low-precision cache line is generated for 8- or 16-bit inputs, correspondingly. Potential problems include:

- the number of loads and stores of the same cache line increases 4X or 2X, respectively.
- the next round of processing of the same cache line may occur after this cache line is evicted from DCU.

One of the optimizations mitigating these performance issues is to collect enough high-precision outputs, so that conversion of the full low-precision cache line will be performed in a single round.

The following drawing shows the conversion flow of 32-bit integers to 8-bit integers. Each colored block at the top represents a single **full** TILE output (horizontal dimension is OFMs, vertical dimension is spatial).

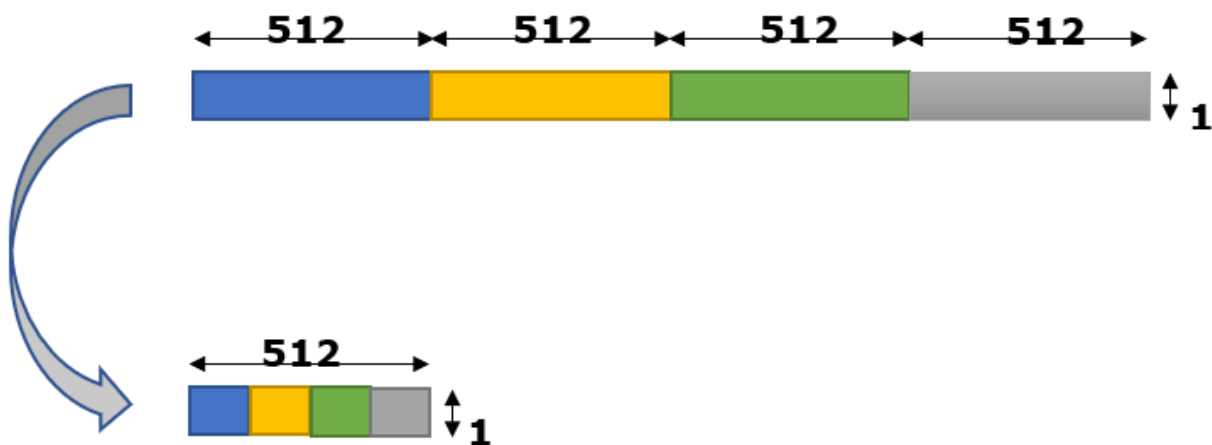

Figure 20-13. A Conversion Flow of 32-bit Integers to 8-bit Integers

To generate full 512-bit cache lines of 8-bit inputs (bottom), a multiple of 64 OFMs should be collected before conversion. Accordingly, to generate full cache lines with 16-bit inputs, a multiple of 32 OFMs should be collected. This may be viewed as a restriction to convolution blocking parameters (in particular, `N_ACC`) which nevertheless often produces better performance results.

Below is an example of the conversion code for two blocks of sixteen cache lines of 32-bit floats converted to a single block of sixteen cache lines of 16-bit bfloats. TMUL outputs are assumed to be placed into a scratchpad `spad`, and the conversion result is placed in the `next_inputs` buffer.

Example 20-19. The conversion code for two blocks of sixteen cache lines of 32-bit floats converted to a single block of sixteen cache lines of 16-bit bfloats

```
float* spad;
bfloat_16* next_inputs;
inline unsigned inputs_spatial_dim( void ) {
    return /* number of pixels in map */
}
for (int i = 0; i < 16; i++)
{
    __m512 f32_0 = _mm512_load_ps(spad);
    __m512 f32_1 = _mm512_load_ps(spad + 16*16);
    __m512 bf16 = _mm512_castsi512_ps(_mm512_cvtne2ps_pbh(f32_1, f32_0));
    _mm512_store_ps(next_inputs, bf16);

    spad += 16; /* Next TILE row */
    next_inputs += 32 * inputs_spatial_dim();
}

```

Converting 32-bit integers to 8-bit integers without compromising DL network accuracy is more involved and uses a quantization step before packing. Below is presented a routine for efficient packing of four cache lines of 32-bit integers into a single cache line of 8-bit integers, using *unsigned saturation*.

Example 20-20. Using Unsigned Saturation

```

const int32_t db_sel[16] = { 0, 4, 8, 12, 1, 5, 9, 13, 2, 6, 10, 14, 3, 7, 11, 15 };
inline __m512i Pack_DwordsToBytes(__m512i dwords[4])
{
    const __m512i sel_reg = _mm512_load_si512(db_sel);
    const __m512i words_0 = _mm512_packs_epi32(dwords[0], dwords[1]);
    const __m512i words_1 = _mm512_packs_epi32(dwords[2], dwords[3]);
    __m512i bytes      = _mm512_packus_epi16(words_0, words_1);
    bytes              = _mm512_permutexvar_epi32(sel_reg, bytes);

    return bytes;
}

```

20.12 INPUT AND OUTPUT BUFFERS REUSE (AKA DOUBLE BUFFERING)

Due to the significant computational speedup achieved by the Intel AMX instructions, the performance bottleneck of Intel AMX-enabled applications is usually the memory accesses. A prominent way to improve memory utilization is to reduce an application's memory footprint. An application with a smaller memory footprint will keep more of its essential data in the caches while reducing the number of costly cache evictions, potentially improving performance considerably.

In the context of Deep Learning, a simple yet efficient way to reduce the memory footprint is to reuse the input and output buffers of various layers in the topology.

The following simple topology illustrates where the previous layer feeds the next layer (left):

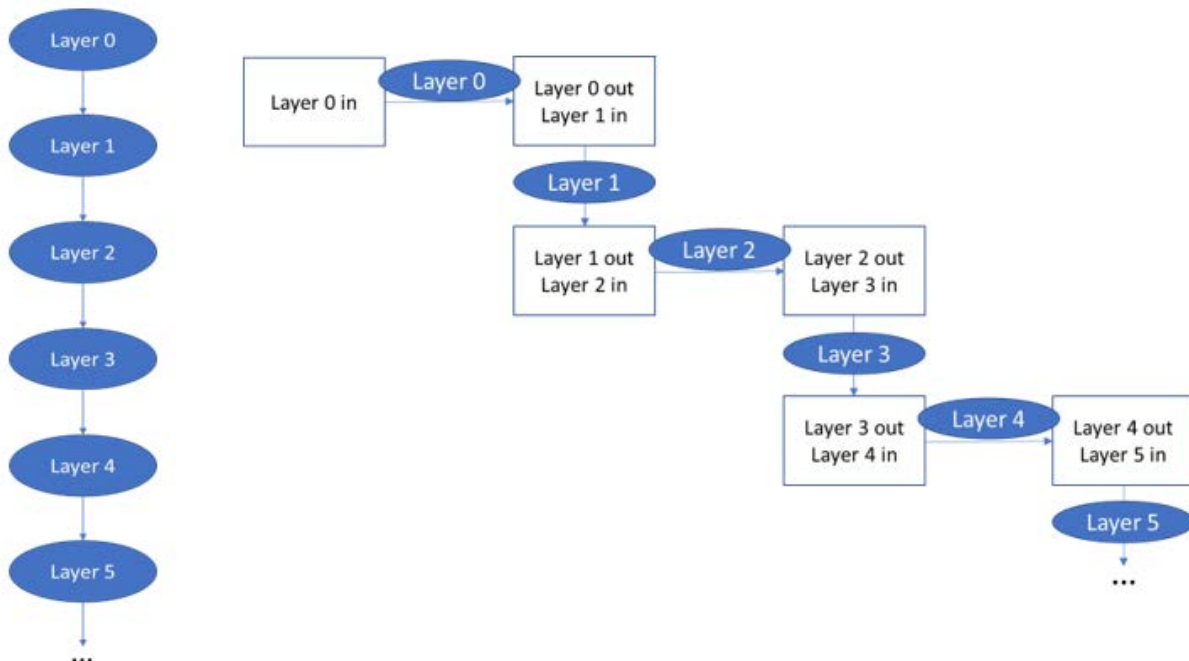

Figure 20-14. Trivial Deep Learning Topology with Naive Buffer Allocation

A straightforward buffer allocation scheme is illustrated on the right, in which the output of layer N is placed into a dedicated memory buffer which is then consumed as input by layer N+1. In this scheme, such topology with L-layers would require L+1 memory buffers, of which only the last is of value (contains the final results). The rest of the L memory buffers are single-use and disposable, significantly increasing the application's memory footprint.

The allocation scheme below offers an improved scheme:



Figure 20-15. Minimal Memory Footprint Buffer Allocation Scheme for the Trivial Deep Learning Topology

In this scheme, the entire topology only requires two reusable memory buffers. A more complex topology would require more reusable buffers, but this number is significantly smaller than the naïve approach. ResNet-50, for example, requires only three reusable buffers (instead of 55). Inception-ResNet-V2 requires only five reusable buffers (instead of over 250). This optimization resulted in a 25% improved performance on the int8 end-to-end large batch throughput run of Resnet50 v1.5.

20.13 SOFTWARE PREFETCHES

The CPU employs sophisticated HW prefetchers that predict future access and provide relevant data. This works best when most memory accesses are sequential. For more details on processor hardware prefetchers, see Section 20.2.8.2.

20.13.1 SOFTWARE PREFETCH FOR CONVOLUTION AND GEMM LAYERS

Since the Conv/GEMM kernel is centered around loops over the M, K, and N dimensions of the involved matrices, the access will often be sequential. However, memory blocking, also recommended in this guide, causes the CPU to re-use the same block in the A or B matrices (or both) multiple times during the kernel execution. This means that sometimes the HW prefetcher cannot predict the subsequent access correctly. This opens the opportunity for an SW prefetch algorithm tightly integrated into the Conv/GEMM kernel and can bring in cache lines from future blocks based on the blocking strategy.

While the SW prefetch instruction enables selecting the target cache hierarchy level for the prefetch, this document assumes that the prefetch will go to the MLC. The DCU is too small to prevent the prefetched lines from being evicted before they can be used, and prefetching to LLC may not yield significant improvement.

20.13.1.1 The Prefetch Strategy

The prefetch strategy is highly dependent on the Conv/GEMM kernel method of operation. Assuming the "loops and blocking" design discussed earlier, the kernel operation can probably be split into multiple phases where each phase manages a different part of the matrices (corner, middle, etc.). To avoid overflowing the instruction cache, the developer is encouraged to reduce the program's size by reusing sections for repeatable matrix patterns. This can be done by having each section work on relative

addresses. The SW prefetch instruction can be integrated into these sections and work on relative addresses. This means that while one section of the code is loading addresses for its use, it also prefetches memory for a future section. The future section can be determined by looking at the future indices of any of the M/K/N loop levels.

20.13.1.2 Prefetch Distance

One of the most important decisions when using SW prefetching is the distance between the current address and the prefetched address. Supposing that some blocking strategy is employed, it is not as simple as adding an offset to the current address. The prefetched address must be set based on the target block of the matrix. If the target block is too close, the prefetched memory might still be in transit when the memory is required, and the CPU will stall, waiting for it to arrive. The data might be evicted if prefetched memory is too distant before it is used. The developer must tune the distance based on the layer/blocking parameters.

As an example heuristic,

- one or two loads for each TMUL operation
- where one matrix is already in a register
- when two registers must be loaded
- the recommended range between the prefetch time and the consumption time is between 100 and 500 TMUL operations
- 100 TMUL operations should take about 1600 cycles
- the maximum number of bytes loaded between prefetch and consumption is 1MB (500 TMUL ops /* 2 loads per ops /* 1K per tile)
- the optimum is probably closer to 100 TMUL ops. At any rate, the developer must check the current CPU architecture and make sure that the MLC will not overflow

20.13.1.3 To Prefetch A or Prefetch B?

Whether to prefetch A or B, or both depends on

The order of layer execution.

In general, the following approaches are available:

- Image affinity
- Execute the next layer of the same image
- Complete a single image end-to-end before continuing to the next image in the same mini-batch.

Layer affinity:

- Execute the same layer of the following image
- Complete a layer for all images in the mini-batch before continuing to the next layer

The activations (the result of the previous layer) in the CPU caches are seen when image affinity is used. The weights in the caches are found when layer affinity is used. Generally, image affinity is recommended when $\text{sizeof}(A) > \text{sizeof}(B)$ and layer affinity otherwise. The developer should tune the switch point between the two methods to maximize performance. The choice between these two methods is also affected by the target matrix for prefetching. If the developer is confident that one of the matrices will already be present in the cache when the Conv/GEMM kernel begins execution, the potential benefit of SW prefetching decreases dramatically.

The size of the A-matrix, B-matrix, and cache.

The developer should sum up the memory requirements of the Conv/GEMM kernel for the current layer and compare it to the size of the cache (MLC). Combined with the previous step, it can indicate whether

SW prefetching can yield any performance benefit. When large matrices are involved, there is a greater chance for improvement when prefetching both the A- and the B-matrices.

20.13.1.4 To Prefetch or not to Prefetch C?

Actually it is not the C-matrix itself that we might want to prefetch, but rather the final output matrix of the layer, after its post-convolution or post-GEMM phase, including quantization to a lower precision data type. Generally, prefetch those cache lines ahead of time, since with double buffering these might have been read by previous layers, possibly executed in other cores.

Use the PREFETCHW instruction to read those cache lines into the DCU just in time for the store operations to find them in the DCU ready to be written, avoiding Read For Ownership latency that otherwise delays store completion. The exact timing of issuing the PREFETCHW instruction depends on multiple factors and requires careful tuning to get it right.

20.13.2 SOFTWARE PREFETCH FOR EMBEDDING LAYER

When the memory access pattern is semi-random, it is often impossible for the HW prefetcher to predict since the pattern is based on application logic. In this case, the application may benefit from “proactive” prefetching using the SW prefetch instructions of addresses the application knows it will access soon.

An excellent example is Deep Learning, wherein the recommendation systems often use the embedding layer. The core loop of the embedding algorithm loads indices from an index buffer, and for each index it loads the corresponding row from the embedding table for further processing. While the index buffer may contain duplicate indices that may benefit from CPU caching, the pattern is still considered random or semi-random in most cases. This can make the HW prefetcher less efficient. Since the entire content of the index buffer is already known, rows soon to be encountered can be prefetched to the DCU.

Example 20-21. Prefetching Rows to the DCU

```

1 void prefetched_embedding(uint32_t *a, float *e, float *c, size_t num_indices,
2     float scale, float bias, size_t lookahead)
3 {
4     __m512 s = _mm512_set1_ps(scale);
5     __m512 b = _mm512_set1_ps(bias);
6
7     for (size_t i = 0; i < num_indices; i++) {
8         _mm_prefetch(
9             (char const *)&e[a[i] + lookahead] * FLOATS_PER_CACHE_LINE,
10            _MM_HINT_T0);
11        __m512 ereg =
12            _mm512_load_ps(&e[((size_t)a[i]) * FLOATS_PER_CACHE_LINE]);
13        __m512 creg = _mm512_fmadd_ps(ereg, s, b);
14        _mm512_store_ps(&c[i * FLOATS_PER_CACHE_LINE], creg);
15    }
16 }
```

20.14 STORE TO LOAD FORWARDING

Store instructions copy data from general purpose, vector, or tile registers into store buffers before that data gets written to the DCU (first level cache). All load instructions, other than TileLoad, can load the data they are looking for from the store buffers in addition to the memory hierarchy.

The TileLoad instruction can't load data from store buffers. It can only detect that the data is there and needs to wait until it is written to the memory hierarchy. Once written, TileLoad can read it from the memory hierarchy. This incurs a significant slowdown.

TileStore forwarding to non-TileLoad instructions via store buffers is supported under one restriction: they both have to be of cache line size (64 bytes).

Generally speaking, forwarding is not advised since this mechanism has outliers. To avoid store-to-load forwarding, ensure enough distance between those two operations in the order of 10s of cycles in time.

20.15 MATRIX TRANSPOSE

This section describes the best-known SW implementations for several matrix transformations of BF16 data.

Henceforth, "flat format" means normal (i.e., non-VNNI) and no blocking of rows (i.e., rows of matrices occupy a consecutive region in memory). The first condition is essential; the second could be relaxed by changing the below code accordingly. "VNNI format" implies only the second condition (non-blocking of rows).

It is important to note that the MxN matrix in *flat* format will be represented by a $(M/2) \times (N/2)$ matrix in VNNI format under the definitions above.

20.15.1 FLAT-TO-FLAT TRANSPOSE OF BF16 DATA

The primitive block transposed in this algorithm is 32x8 (i.e., 32 rows, eight BF16 numbers each), which is transformed into an 8x32 block (i.e., eight rows of 32 BF16 numbers each).

The implementation uses sixteen ZMM registers and three mask registers.

Input parameters: MxN, sizes of the rectangular block to be transposed; it is assumed that M is a multiple of 32, and N is a multiple of eight. In the following illustration, assume:

- I_STRIDE is the row size of the input matrix in bytes.
- O_STRIDE is the row size of the output buffer in bytes.
- r8 contains starting address of the input matrix.
- r9 contains starting address of the output buffer.

Example 20-22. BF16 Matrix Transpose (32x8 to 8x32)

```

/*1 of 3 */
1  mov    r10,    0xf0
2  kmovd  k1,    r10d
3  mov    r10,    0xf00
4  kmovd  k2,    r10d
5  mov    r10,    0xf000
6  kmovd  k3,    r10d
7  mov    rax,    N / 8
L.N:
8  mov    rdx,    M / 32
L.M:
9  vbroadcasti32x4 zmm0,          xmmword ptr [r8]
10 vbroadcasti32x4 zmm0{k1},     xmmword ptr [r8+_STRIDE*8]
11 vbroadcasti32x4 zmm0{k2},     xmmword ptr [r8+_STRIDE*16]
12 vbroadcasti32x4 zmm0{k3},     xmmword ptr [r8+_STRIDE*24]
13 vbroadcasti32x4 zmm1,          xmmword ptr [r8+_STRIDE*1]
14 vbroadcasti32x4 zmm1{k1},     xmmword ptr [r8+_STRIDE*9]
15 vbroadcasti32x4 zmm1{k2},     xmmword ptr [r8+_STRIDE*17]
16 vbroadcasti32x4 zmm1{k3},     xmmword ptr [r8+_STRIDE*25]
17 vbroadcasti32x4 zmm2,          xmmword ptr [r8+_STRIDE*2]
18 vbroadcasti32x4 zmm2{k1},     xmmword ptr [r8+_STRIDE*10]
19 vbroadcasti32x4 zmm2{k2},     xmmword ptr [r8+_STRIDE*18]
20 vbroadcasti32x4 zmm2{k3},     xmmword ptr [r8+_STRIDE*26]

```



```

/*2 of 3 */
21 vbroadcasti32x4 zmm3,          xmmword ptr [r8+_STRIDE*3]
22 vbroadcasti32x4 zmm3{k1},     xmmword ptr [r8+_STRIDE*11]
23 vbroadcasti32x4 zmm3{k2},     xmmword ptr [r8+_STRIDE*19]
24 vbroadcasti32x4 zmm3{k3},     xmmword ptr [r8+_STRIDE*27]
25 vbroadcasti32x4 zmm4,          xmmword ptr [r8+_STRIDE*4]
26 vbroadcasti32x4 zmm4{k1},     xmmword ptr [r8+_STRIDE*12]
27 vbroadcasti32x4 zmm4{k2},     xmmword ptr [r8+_STRIDE*20]
28 vbroadcasti32x4 zmm4{k3},     xmmword ptr [r8+_STRIDE*28]
29 vbroadcasti32x4 zmm5,          xmmword ptr [r8+_STRIDE*5]
30 vbroadcasti32x4 zmm5{k1},     xmmword ptr [r8+_STRIDE*13]
31 vbroadcasti32x4 zmm5{k2},     xmmword ptr [r8+_STRIDE*21]
32 vbroadcasti32x4 zmm5{k3},     xmmword ptr [r8+_STRIDE*29]
33 vbroadcasti32x4 zmm6,          xmmword ptr [r8+_STRIDE*6]
34 vbroadcasti32x4 zmm6{k1},     xmmword ptr [r8+_STRIDE*14]
35 vbroadcasti32x4 zmm6{k2},     xmmword ptr [r8+_STRIDE*22]
36 vbroadcasti32x4 zmm6{k3},     xmmword ptr [r8+_STRIDE*30]
37 vbroadcasti32x4 zmm7,          xmmword ptr [r8+_STRIDE*7]
38 vbroadcasti32x4 zmm7{k1},     xmmword ptr [r8+_STRIDE*15]
39 vbroadcasti32x4 zmm7{k2},     xmmword ptr [r8+_STRIDE*23]
40 vbroadcasti32x4 zmm7{k3},     xmmword ptr [r8+_STRIDE*31]
41 vpunpcklwd  zmm8,  zmm0,  zmm1
42 vpunpckhwd  zmm9,  zmm0,  zmm1
43 vpunpcklwd  zmm10, zmm2,  zmm3
44 vpunpckhwd  zmm11, zmm2,  zmm3
45 vpunpcklwd  zmm12, zmm4,  zmm5
46 vpunpckhwd  zmm13, zmm4,  zmm5
47 vpunpcklwd  zmm14, zmm6,  zmm7
48 vpunpckhwd  zmm15, zmm6,  zmm7
49 vpunpckldq  zmm0,  zmm8,  zmm10
50 vpunpckhdq  zmm1,  zmm8,  zmm10
51 vpunpckldq  zmm2,  zmm9,  zmm11
52 vpunpckhdq  zmm3,  zmm9,  zmm11
53 vpunpckldq  zmm4,  zmm12, zmm14
54 vpunpckhdq  zmm5,  zmm12, zmm14
55 vpunpckldq  zmm6,  zmm13, zmm15
56 vpunpckhdq  zmm7,  zmm13, zmm15
57 vpunpcklqdq zmm8,  zmm0,  zmm4
58 vpunpckhqdq zmm9,  zmm0,  zmm4
59 vpunpcklqdq zmm10, zmm1,  zmm5
60 vpunpckhqdq zmm11, zmm1,  zmm5
61 vpunpcklqdq zmm12, zmm2,  zmm6
62 vpunpckhqdq zmm13, zmm2,  zmm6
63 vpunpcklqdq zmm14, zmm3,  zmm7
64 vpunpckhqdq zmm15, zmm3,  zmm7

```

```
/*3 of 3*/
65 vmovdqu16 zmmword ptr [r9], zmm8
66 vmovdqu16 zmmword ptr [r9+O_STRIDE], zmm9
67 vmovdqu16 zmmword ptr [r9+O_STRIDE*2], zmm10
68 vmovdqu16 zmmword ptr [r9+O_STRIDE*3], zmm11
69 vmovdqu16 zmmword ptr [r9+O_STRIDE*4], zmm12
70 vmovdqu16 zmmword ptr [r9+O_STRIDE*5], zmm13
71 vmovdqu16 zmmword ptr [r9+O_STRIDE*6], zmm14
72 vmovdqu16 zmmword ptr [r9+O_STRIDE*7], zmm15

73 add r9, 0x40
74 add r8, I_STRIDE*32
75 dec rdx
76 jnz LM

77 add r9, (O_STRIDE*8 - (M/32) * 0x40)
78 sub r8, (I_STRIDE*M-0x10)
79 dec rax
80 jnz LN
```

Implementation discussion:

- Lines 1-6 set mask registers k1, k2, k3.
- Lines 7 and 8 put trip counts for primitive blocks in N- and M-dimensions, respectively.
- Lines 9-72 implement the transpose of a primitive block 32x8. It uses 16 ZMM registers (zmm0-zmm15).
- Lines 9-40 implement loading 32 quarter-cache lines into 8 ZMM registers, according to the following picture (numbers are in **bytes**):

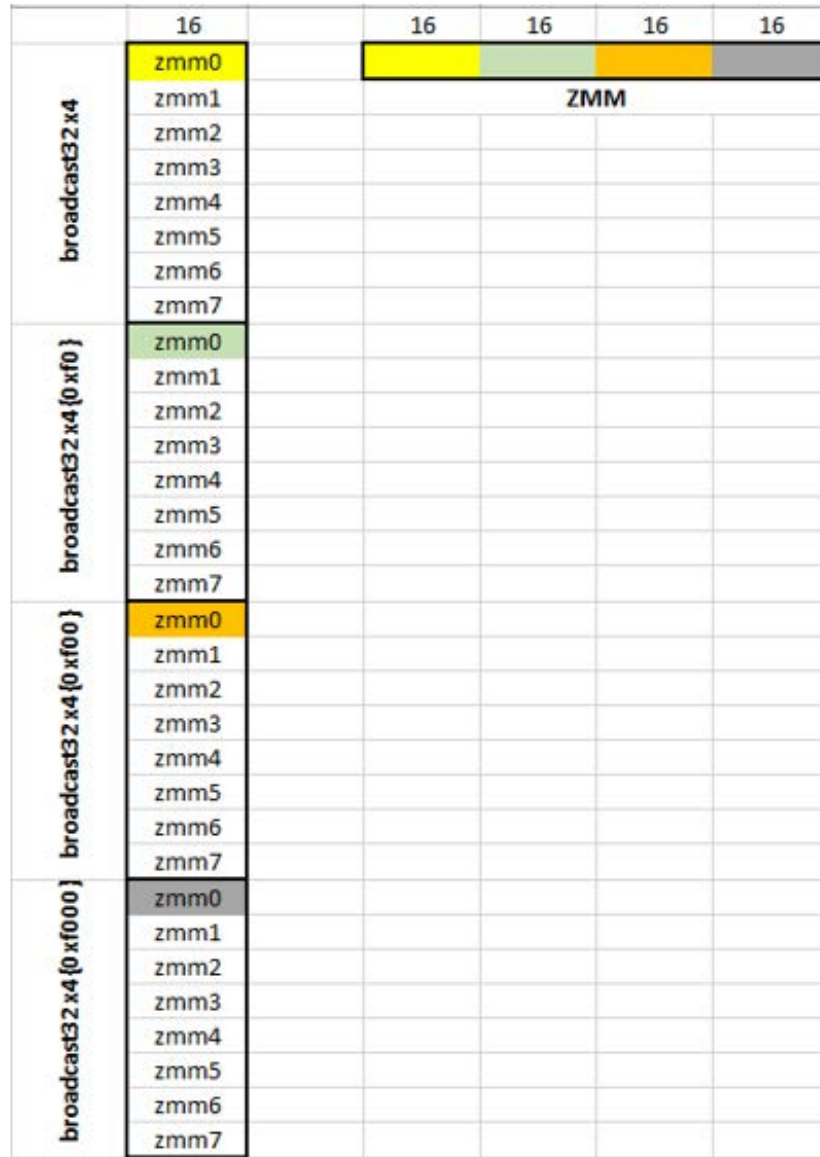

Figure 20-16. Loading 32 Quarter-Cache Lines into 8 ZMM Registers

- Lines 41-64 are transpose flow proper. It creates a transposed block 8x32 in registers zmm8-zmm15.
- Lines 65-72 store transposed block 8x32 to the output buffer.

20.15.2 VNNI-TO-VNNI TRANSPOSE

The primitive block transposed in this algorithm is 8x8 (i.e., eight rows, eight BF16 numbers each), which is transformed into a2x32 block (i.e., two rows of 32 BF16 numbers each).

The implementation uses five ZMM registers and three mask registers.

Input parameters:

- MxN, sizes of the rectangular block to be transposed (*in VNNI format*); it is assumed that M, N are multiples of eight.
- I_STRIDE is the row size of the input matrix in bytes
- O_STRIDE is the row size of the output buffer in bytes
- r8 contains starting address to the input matrix
- r9 contains starting address to the output buffer
- zmm31 is preloading with four copies of the following constant: `unsigned int shuffle_cntrl[4] = {0x05040100, 0x07060302, 0x0d0c0908, 0x0f0e0b0a};`

Example 20-23. BF16 VNNI to VNNI Transpose (8x8 to 2x32)

```

1  mov r10, 0xf0
2  kmovd k1, r10d
3  mov r10, 0xf00
4  kmovd k2, r10d
5  mov r10, 0xf000
6  kmovd k3, r10d
7  mov rax, N / 8
L.N:
8  mov rdx, M / 8
L.M:
9  vbroadcasti32x4 zmm0, xmmword ptr [r8]
10 vbroadcasti32x4 zmm0{k1}, xmmword ptr [r8+_STRIDE*2]
11 vbroadcasti32x4 zmm0{k2}, xmmword ptr [r8+_STRIDE*4]
12 vbroadcasti32x4 zmm0{k3}, xmmword ptr [r8+_STRIDE*6]
13 vbroadcasti32x4 zmm1, xmmword ptr [r8+_STRIDE*1]
14 vbroadcasti32x4 zmm1{k1}, xmmword ptr [r8+_STRIDE*3]
15 vbroadcasti32x4 zmm1{k2}, xmmword ptr [r8+_STRIDE*5]
16 vbroadcasti32x4 zmm1{k3}, xmmword ptr [r8+_STRIDE*7]

17 vpshufb zmm2, zmm0, zmm31
18 vpshufb zmm3, zmm1, zmm31
19 vpunpcklqdq zmm0, zmm2, zmm3
20 vpunpckhqdq zmm1, zmm2, zmm3

21 vmovdqu16 zmmword ptr [r9], zmm0
22 vmovdqu16 zmmword ptr [r9+_STRIDE], zmm1

23 add r9, 0x40
24 add r8, _STRIDE*8
25 dec rdx
26 jnz L.M

27 add r9, (_STRIDE*2 - (M/8) * 0x40)
28 sub r8, (_STRIDE*M-0x10)
29 dec rax
30 jnz L.N

```

Implementation discussion:

- Lines 1–6 set mask registers k1, k2, k3.
- Lines 7 and 8 put trip counts for primitive blocks in N- and M-dimensions, respectively.
- Lines 9–22 implement the transpose of a primitive block 32x8. It uses five ZMM registers (zmm0-zmm3, zmm31).
- Lines 9–16 implement loading eight quarter-cache lines into two ZMM registers, according to the following picture (numbers are in bytes):

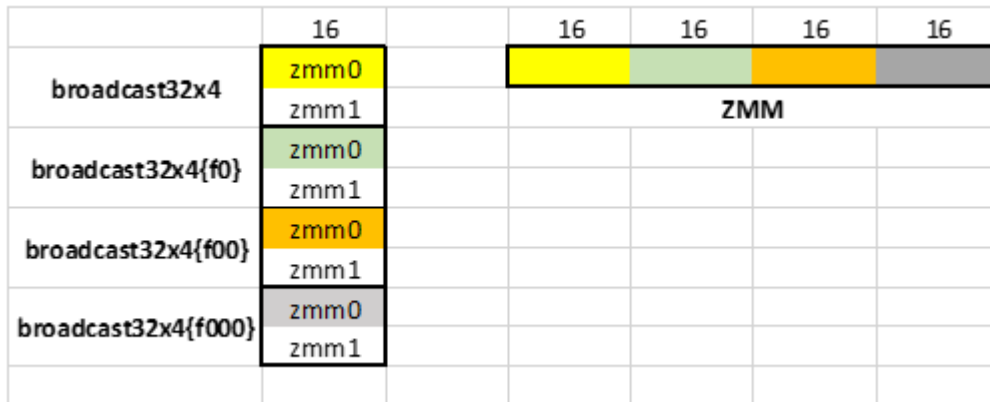

Figure 20-17. The Implementation of loading eight quarter-cache lines into two ZMM registers

- Lines 17–20 implement simultaneous transpose of four 2x2 blocks of QWORDS (i.e., 2x8 blocks of BF16). It creates a transposed block 2x32 in registers zmm2-zmm3.
- Lines 21–22 store transposed block 2x32 to the output buffer.

20.15.3 FLAT-TO-VNNI TRANSPOSE

The algorithm below is based on: Flat-to-VNNI transpose of WORDs is equivalent to Flat-to-Flat transpose of DWORDs. This is illustrated below (the header numbers are bytes):

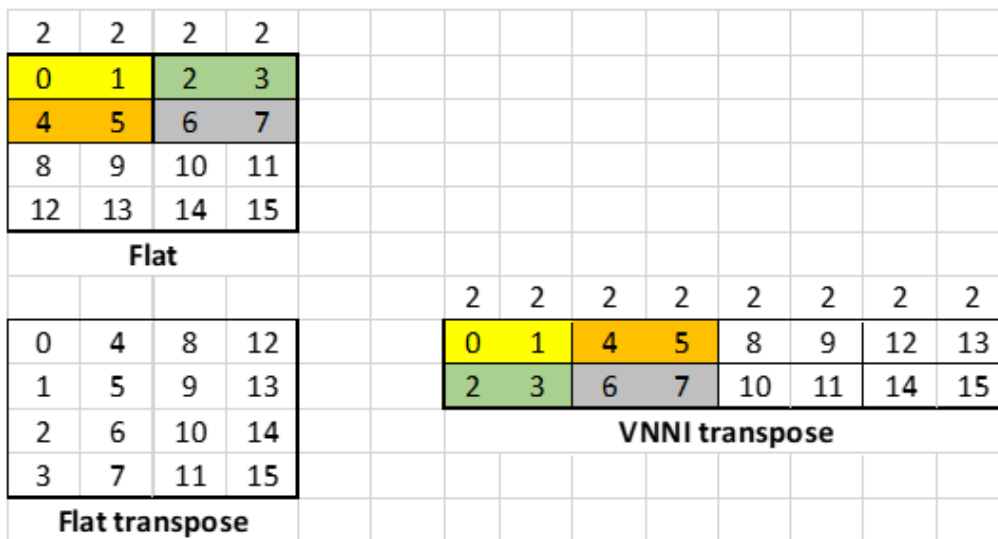

Figure 20-18. Flat-to-VNNI transpose of WORDs is equivalent to Flat-to-Flat transpose of DWORDs

The primitive block transposed in this algorithm is 16x8 (i.e., 16 rows, 8 BF16 numbers each), which is transformed into a 4x32 block (i.e., four rows of 32 BF16 numbers each).

The implementation uses eight ZMM registers and three mask registers.

Input parameters:

- $M \times N$, sizes of the rectangular block to be transposed; it is assumed that M multiple of 16, N multiple of eight.
- `I_STRIDE` is the row size of the input matrix in bytes.
- `O_STRIDE` is the row size of the output buffer in bytes.
- `r8` contains the starting address for the input matrix.
- `r9` contains the starting address for the output buffer.

Example 20-24. BF16 Flat to VNNI Transpose (16x8 to 4x32)

```

1  mov r10, 0xf0
2  kmovd k1, r10d
3  mov r10, 0xf00
4  kmovd k2, r10d
5  mov r10, 0xf000
6  kmovd k3, r10d
7  mov rax, N / 8
L.N:
8  mov rdx, M / 16
L.M:
9  vbroadcasti32x4 zmm0, xmmword ptr [r8]
10 vbroadcasti32x4 zmm0{k1}, xmmword ptr [r8+_STRIDE*4]
11 vbroadcasti32x4 zmm0{k2}, xmmword ptr [r8+_STRIDE*8]
12 vbroadcasti32x4 zmm0{k3}, xmmword ptr [r8+_STRIDE*12]
13 vbroadcasti32x4 zmm1, xmmword ptr [r8+_STRIDE*1]
14 vbroadcasti32x4 zmm1{k1}, xmmword ptr [r8+_STRIDE*5]
15 vbroadcasti32x4 zmm1{k2}, xmmword ptr [r8+_STRIDE*9]
16 vbroadcasti32x4 zmm1{k3}, xmmword ptr [r8+_STRIDE*13]
17 vbroadcasti32x4 zmm2, xmmword ptr [r8+_STRIDE*2]
18 vbroadcasti32x4 zmm2{k1}, xmmword ptr [r8+_STRIDE*6]
19 vbroadcasti32x4 zmm2{k2}, xmmword ptr [r8+_STRIDE*10]
20 vbroadcasti32x4 zmm2{k3}, xmmword ptr [r8+_STRIDE*14]
21 vbroadcasti32x4 zmm3, xmmword ptr [r8+_STRIDE*3]
22 vbroadcasti32x4 zmm3{k1}, xmmword ptr [r8+_STRIDE*7]
23 vbroadcasti32x4 zmm3{k2}, xmmword ptr [r8+_STRIDE*11]
24 vbroadcasti32x4 zmm3{k3}, xmmword ptr [r8+_STRIDE*15]

25 vpunpckldq zmm4, zmm0, zmm1
26 vpunpckhdq zmm5, zmm0, zmm1
27 vpunpckldq zmm6, zmm2, zmm3
28 vpunpckhdq zmm7, zmm2, zmm3
29 vpunpcklqdq zmm0, zmm4, zmm6
30 vpunpckhqdq zmm1, zmm4, zmm6
31 vpunpcklqdq zmm2, zmm5, zmm7
32 vpunpckhqdq zmm3, zmm5, zmm7

33 vmovups zmmword ptr [r9], zmm0
34 vmovups zmmword ptr [r9+O_STRIDE], zmm1
35 vmovups zmmword ptr [r9+O_STRIDE*2], zmm2
36 vmovups zmmword ptr [r9+O_STRIDE*3], zmm3

37 add r9, 0x40
38 add r8, _STRIDE*16
39 dec rdx
40 jnz L.M

41 add r9, (O_STRIDE*4 - (M/16)*0x40)
42 sub r8, (_STRIDE*M-0x10)
43 dec rax
44 jnz L.N

```

Implementation discussion:

- Lines 1–6 set mask registers k1, k2, k3.
- Lines 7 and 8 put trip counts for primitive blocks in N- and M-dimensions, respectively.
- Lines 9–36 implement the transpose of a primitive block 16x8. It uses eight ZMM registers (zmm0–zmm7).
- Lines 9–24 implement loading 16 quarter-cache lines into four ZMM registers zmm0–zmm3, according to the following picture (numbers are in bytes):

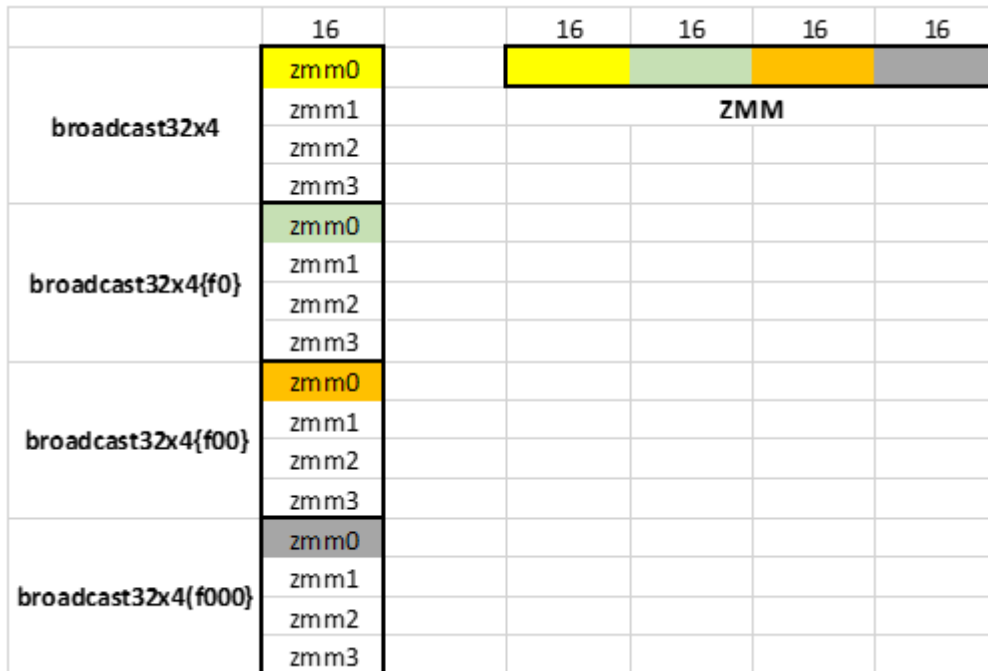

Figure 20-19. BF16 Flat-to-VNNI Transpose

- Lines 25–32 are the transpose flow proper. It creates a transposed block 4x32 in registers zmm0–zmm3.
- Lines 33–36 store transposed block 4x32 to the output buffer.

20.15.4 FLAT-TO-VNNI RE-LAYOUT

The primitive block which is being re-layout in this algorithm is 2x32 (i.e., 2 rows, 32 BF16 numbers each), which is transformed into a 1x64 block (i.e., 1 rows of 64 BF16 numbers each).

The implementation uses **5 ZMM registers and no mask registers**.

Input parameters:

- MxN, sizes of the rectangular block to be transposed; it is assumed that **M multiple of 2, N multiple of 32**.
- I_STRIDE is the row size of input matrix in **bytes**.
- O_STRIDE is the row size of output buffer in **bytes**.
- r8 contains starting address to input matrix.
- r9 contains starting address to output buffer.
- zmm30, zmm31 are preloaded with following constants, respectively:
- `const short perm_cntl_1[32] = {0x00, 0x20, 0x01, 0x21, 0x02, 0x22, 0x03, 0x23, 0x04, 0x24, 0x05, 0x25, 0x06, 0x26, 0x07, 0x27, 0x08, 0x28, 0x09, 0x29, 0x0a, 0x2a, 0x0b, 0x2b, 0x0c, 0x2c, 0x0d, 0x2d, 0x0e, 0x2e, 0x0f, 0x2f};`
- `const short perm_cntl_2[32] = {0x30, 0x10, 0x31, 0x11, 0x32, 0x12, 0x33, 0x13, 0x34, 0x14, 0x35, 0x15, 0x36, 0x16, 0x37, 0x17, 0x38, 0x18, 0x39, 0x19, 0x3a, 0x1a, 0x3b, 0x1b, 0x3c, 0x1c, 0x3d, 0x1d, 0x3e, 0x1e, 0x3f, 0x1f};`

Example 20-25. BF16 Flat-to-VNNI Re-Layout

```

1  mov rdx, M / 2
L.M:
2  mov rax, N / 32
L.N:
3  vmovups zmm0, zmmword ptr [r8]
4  vmovups zmm1, zmmword ptr [r8+I_STRIDE]

5  vmovups zmm2, zmm0
6  vpermt2w zmm2, zmm30, zmm1
7  vpermt2w zmm1, zmm31, zmm0

8  vmovups zmmword ptr [r9], zmm2
9  vmovups zmmword ptr [r9+0x40], zmm1

10 add r9, 0x80
11 add r8, 0x40
12 dec rax
13 jnz L.N

14 add r9, (O_STRIDE - (N/32)*0x80)
15 add r8, (I_STRIDE*2 - (N/32)*0x40)
16 dec rdx
17 jnz L.M

```

Implementation discussion:

- Lines 1, 2 put trip counts for primitive blocks in N- and M-dimensions, respectively.
- Lines 3, 4 implement loading 2 full cache lines into 2 ZMM registers zmm0-zmm1, from consecutive rows of input matrix.

- Lines 5–7 implement re-layout of a primitive block 2x32. It uses 5 ZMM registers (zmm0–zmm2, zmm30–zmm31).
- Lines 8, 9 implement storing 2 full cache lines in 2 ZMM registers zmm1–zmm2, into consecutive columns of output matrix.

20.16 MULTI-THREADING CONSIDERATIONS

20.16.1 THREAD AFFINITY

As with Intel AVX-512 code, it is advised to fully define thread affinity and object affinity to process a single object in the same physical core, thus keeping the activations in core caches (unless larger than the size of the caches). This advice becomes imperative with Intel AMX code since Intel AMX applications are more sensitive to memory-related issues.

20.16.2 HYPER-THREADING

Running more than one Intel AMX thread on the same physical core may result in overall performance loss due to the two threads competing for the same h/w resources. Scheduling a non AMX thread next to an AMX thread on the same core may decrease the AMX thread performance more than one expects due to normal competition on resources. For optimum performance, schedule one AMX thread per physical core, if possible

20.16.3 WORK PARTITIONING BETWEEN CORES

Often, a Deep Learning application must adhere to latency requirements that cannot be fulfilled within a single core. In these cases, a single object's processing must be partitioned between multiple cores.

In Deep Learning applications, the output of one layer is the input of the next layer in most cases. Due to the nature of the computations in Deep Learning applications, partitioning over different dimensions (N, M, K) will have different implications on the data locality in the core's caches. If possible, minimize bringing data over from a different core's caches, as this can harm performance.

20.16.3.1 Partitioning over M

Partitioning a DL layer over the M dimension has the advantage of nearly complete data locality. The layer's output is also partitioned by M between the cores and is, therefore, already in the cache of the corresponding core at the beginning of the next layer. Figure 20-20 shows this schematically.

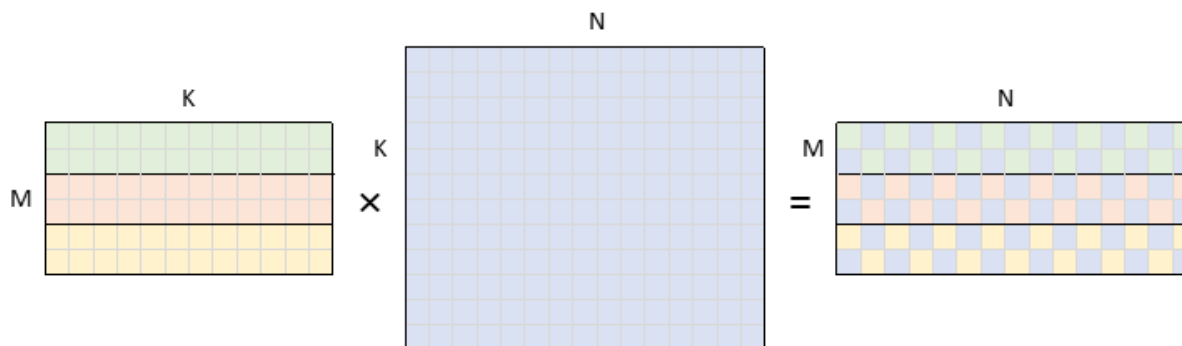

Figure 20-20. GEMM Data Partitioning Between Three Cores in a Layer Partitioned by the M Dimension

In this figure, the data read and written by each of the three cores is bound by a black rectangle. It should be noted that in the case of convolutions, limited overlap in the M dimension of the activations occurs between neighboring cores; due to the convolutions, a finite-sized filter is slid over the activations. Thus, the M dimension overlaps $(KH-1)/*W$ (refer to Example 20-13) between the two neighboring cores.

- Advantages: When multiple layers in a chain are partitioned by the M dimension between the same number of cores, each core has its data in its local cache.
- Disadvantages: The B matrix (or weights in convolutions) is read entirely by all of the cores, which might pose a bandwidth problem if the B matrix is large.

20.16.3.2 Partitioning over N

Partitioning a DL layer over the N dimension reduces the read bandwidth in GEMMs with large B matrices or large weights in convolutions. Each core reads a portion of the B matrix in this scenario:

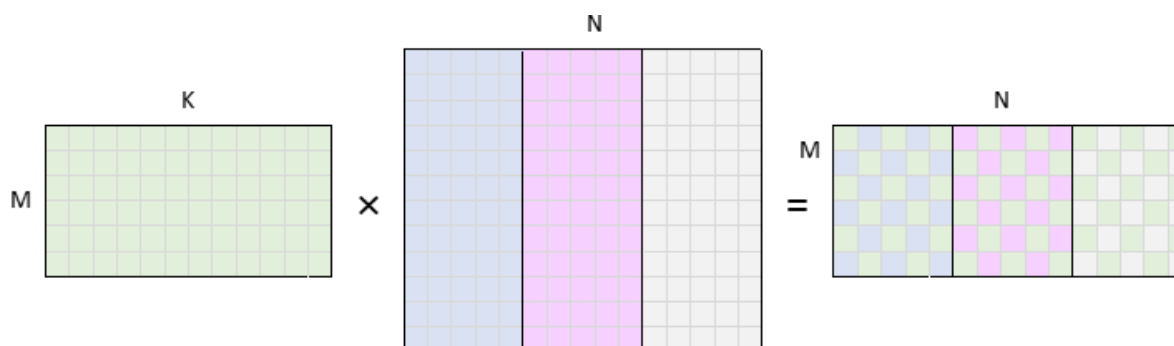

Figure 20-21. GEMM Data Partitioning Between Three Cores in a Layer Partitioned by the N-Dimension

Unfortunately, the output of the layer is also partitioned by the N-dimension between the cores, which is incompatible with M partitioning and N partitioning of the following layer (compare the right side of

Figure 20-21 to the left side of Figure 20-20 and Figure 20-21). In this scenario, a core in the following layer is guaranteed to have most of its data from outside its local caches. This is not the case in K-dimension partitioning (see below), but it also comes at a price.

- Advantages: It may reduce read bandwidth significantly in case of large B / large weights.
- Disadvantages: If the next layer is partitioned by M or by N, most of the activations in the next layer will not reside in the local caches of the corresponding cores.

20.16.3.3 Partitioning over K

Partitioning a DL layer over the K dimension reduces the read bandwidth in GEMMs with large K dimensions by reducing the amount of data being read from A and B matrices (activations and weights in convolutions). Each core reads a portion of the A and B matrices in this scenario, as illustrated in Figure 20-22.

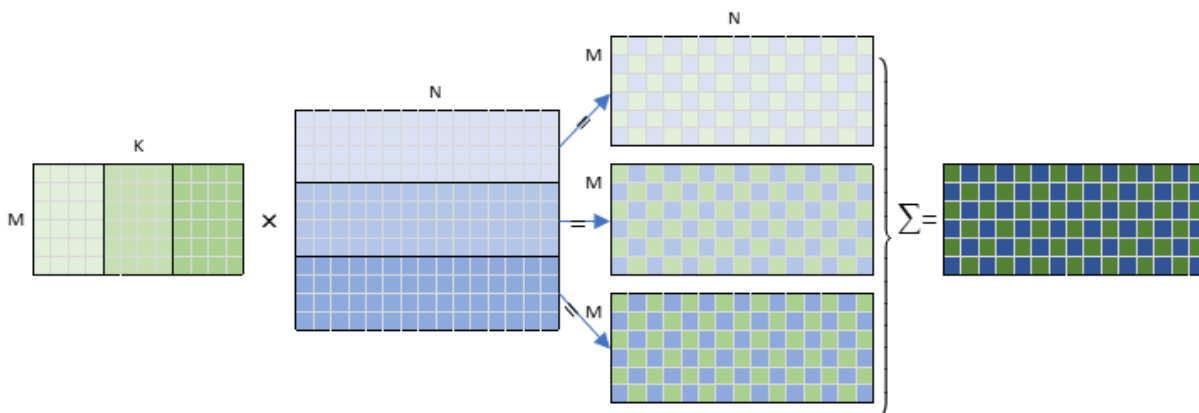

Figure 20-22. GEMM Data Partitioning Between Three Cores in a Layer Partitioned by the K Dimension

Additionally, if a layer is partitioned by the N dimension and the following layer is partitioned by the K dimension, the activation data will reside in the local caches of the cores in the subsequent layer (compare the right side of Figure 20-21 with the left side of Figure 20-22). Unfortunately, this comes at a price: each core prepares partial results of the entire C matrix. To obtain final results, either a mutex (or several mutexes) is required to guard the write operations into the C matrix, or a reduction operation is needed at the end of the layer. The mutex solution is usually ill-advised due to blocked threads for a long time. A reduction runs the risk of being costly since it entails the following:

- A synchronization barrier is required before the reduction.
- Reading a potentially large amount of data during the reduction:
- There are T copies of the C matrix, where T is the number of threads (3 in the example).
- The size of the matrices before the reduction is x2 (in case of a bfloat16 datatype) or x4 (in case of int8 datatype) times larger than the output C matrix.
- During the reduction, most of the cores' data will come outside their local cache hierarchy.

20.16.3.4 Memory Bandwidth Implications of Work Partitioning over Multiple Dimensions

OpenMP offers a convenient interface for nested loop parallelization. For example, one could partition the N, M, and K dimensions in Example 20-26 automatically between threads with:

Example 20-26. GEMM Parallelized with omp Parallel for with Collapse

```
#pragma omp parallel for collapse(2)

for (int n = 0; n < N; n += N_ACC*TILE_N) {
  for (int m = 0; m < M; m += M_ACC*TILE_M) {
    ...
  }
}
```

The collapse clause specifies how many loops in a nested loop should be collapsed into a single iteration space and divided between the threads. The order of the iterations in the collapsed iteration space is the same as though they were executed sequentially.

OpenMP automatically uses `schedule(static,1)` if no schedule is already specified, resulting in the sequential assignment of loop iterations to threads.

Considering, for example, a situation where $N=4*N_ACC*TILE_N$ and $M=4*M_ACC*TILE_M$ where the K-dimension are deliberately excluded from consideration due to its problematic nature. Thus, there are $4*4=16$ iterations in the two nested loops. Now assume you want to divide these between three threads. The code in Section 20-26 would result in the following partition of the iterations between threads:

Table 20-7. Simple partition of work between three threads

							A	B	C
Thread 0:	0,0	0,3	1,2	2,1	3,0	3,3	100%	100%	38%
Thread 1:	0,1	1,0	1,3	2,2	3,1		100%	100%	100%
Thread 2:	0,2	1,1	2,0	2,3	3,2		100%	100%	100%

Where every cell of the form n', m' contains the $n' = n/N_ACC*TILE_N$ and $m' = m/M_ACC*TILE_M$ indices from the loops in Example 20-19.

From the table above, it is clear that each of the three threads executes at least one iteration with $n'=0,1,2,3$ and at least one iteration with $m'=0,1,2,3$. This means that every thread reads all of A and all of B.

By rearranging the work between threads in the following partitioning, the size of the B read is reduced by each thread by 50%, which might be very significant in workloads where B is large. Similarly, the size of A could have been reduced by 50% by simply swapping m' and n' indices for workloads with large A.

Table 20-8. Optimized partition of work between three threads

							A	B	C
Thread 0:	0,0	0,1	0,2	0,3	3,0	3,1	100%	50%	38%
Thread 1:	1,0	1,1	1,2	1,3	3,2	3,3	100%	50%	38%
Thread 2:	2,0	2,1	2,2	2,3			100%	25%	25%

20.16.4 RECOMMENDATION SYSTEM EXAMPLE

Many recommendation systems are built from a few GEMM layers that follow each other, an Embedding layer, and a layer that connects between them. They are generally split into four distinct tasks:

1. Bottom GEMMs (MLPs)
2. Embedding
3. Bottom MLP + Embedding Concat, GEMM, Reshape
4. Top GEMMs (MLPs)

The first two are independent so that they can execute in parallel. Their output feeds the third task, whose output, in turn, feeds into the fourth task.

A few notes:

- Recommendation systems usually use a large batch to rank a reasonably large set of options
- The GEMM layers are usually compute- or cache bandwidth limited, whereas the Embedding layer is memory bandwidth limited
- Recommendation systems are real-time, so they are limited to a specific latency

When the latency requirement is a few milliseconds, the recommendation system topology has to be multi-threaded across several cores. The previous section discussed GEMM partition across multiple cores. This section deals with work partition between the four different tasks.

The chart below proposes one way to split the three tasks across machine cores. The block sizes in the chart, regarding the number of cores and execution time, are for illustration purposes only and do not represent any specific recommendation system.

Thanks to Bottom MLPs and Embedding independence, those are split into two tasks. As those two feed the other tasks: Bottom MLP + Embedding Concat, GEMM, Reshape, and Top MLPs, the latter tasks are merged into one. Choosing the number of cores for each task is a trial-and-error exercise. It can involve an analytical phase that accounts for the time to execute each task across varying cores.

As there's a dependency between the Bottom MLPs and Embedding tasks and the third task, there's a barrier between them which implies potential wait time immediately following the faster layers.

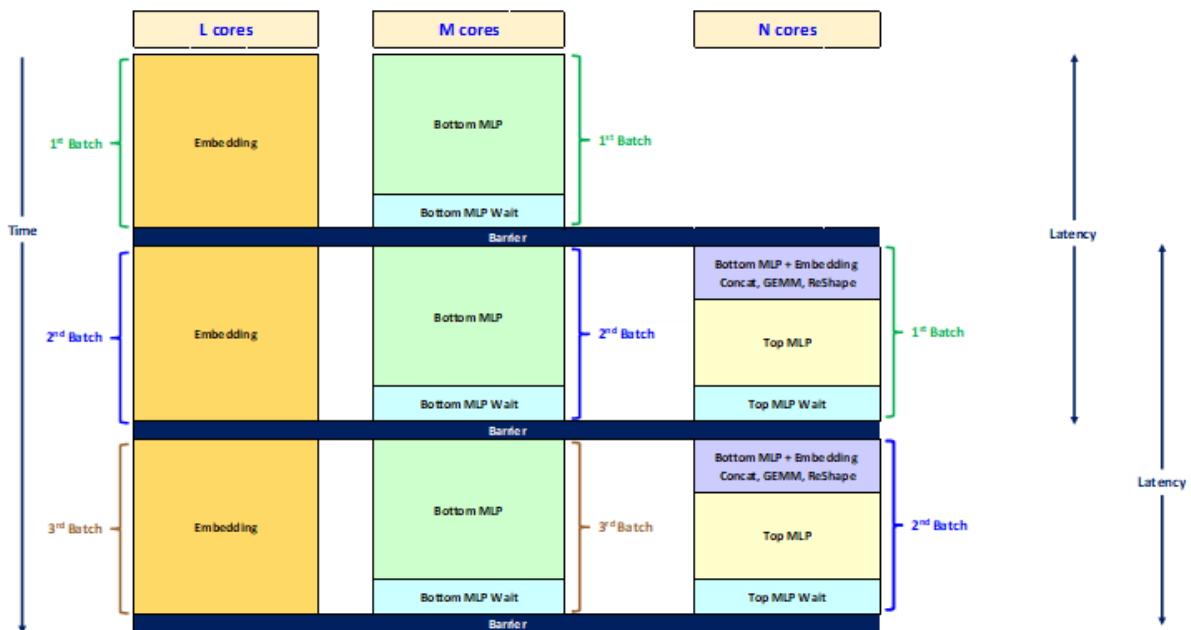

Figure 20-23. A recommendation system multi-threading model

20.17 SPARSITY OPTIMIZATIONS FOR INTEL® AMX

This section describes how Intel AMX can be further optimized for operations on sparse matrices. An example use case can be the inference of sparse neural networks, where the sparse weights are known to initially reside in DRAM due to the “online” usage model or large model capacity. In those cases, the primary performance bottleneck would be bringing the weights from DRAM. A helpful optimization technique for this case is to get the weights from DRAM in a compressed format, decompress them into the local caches using Intel AVX-512 and then perform Intel AMX computations on the decompressed data.

The compressed matrix format can consist of the following components:

- **compressed[]**: array of non-zero matrix entries.
- **mask[]**: bit-per-element array for the full matrix. 0 signifies the corresponding element is 0, 1 signifies a non-zero value that exists in the **compressed[]** array mentioned above.

The compressed format can be computed off-line. The sparsity bitmask **mask[]** can be generated using AVX-512 VPTESTMB instruction on the sparse data. The **compressed[]** array can be generated using AVX-512 VPCOMPRESS instruction on the sparse data using the sparsity bitmask

The following code uses Intel AVX-512 to generate *num* rows of decompressed data, assuming 8-bit elements and 64 elements per tile row:

Example 20-27. Byte Decompression code with Intel® AVX-512 Intrinsics

```
// uint8_t* compressed_ptr is a pointer to compressed data array
// __mmask64* compression_masks_ptr is a pointer to bitmask array
// uint8_t* decompressed_ptr is a pointer to decompressed data array

for (int i=0; i < num ; i++) {
    __m512i compressed = _mm512_loadu_epi32(compressed_ptr);
    __mmask64 mask = _load_mask64(compression_masks_ptr);
    __m512i decompressed_vec = _mm512_maskz_expand_epi8(mask, compressed);
    _mm512_store_epi32(decompressed_ptr, decompressed_vec);
    decompressed_ptr += 64; // 64 bytes per decompressed row
    compressed_ptr += _mm_countbits_64(mask); // advance compressed pointer by number of non-zero elements
    compression_masks_ptr++; //64 bitmask bits per decompressed row
}
```

The matrix multiplication code will load the decompressed matrix to tiles from **decompressed[]**, an array containing the decompressed matrix data.

The decompression code makes use of the Intel AVX-512 data expand operation, as illustrated in the following figure:

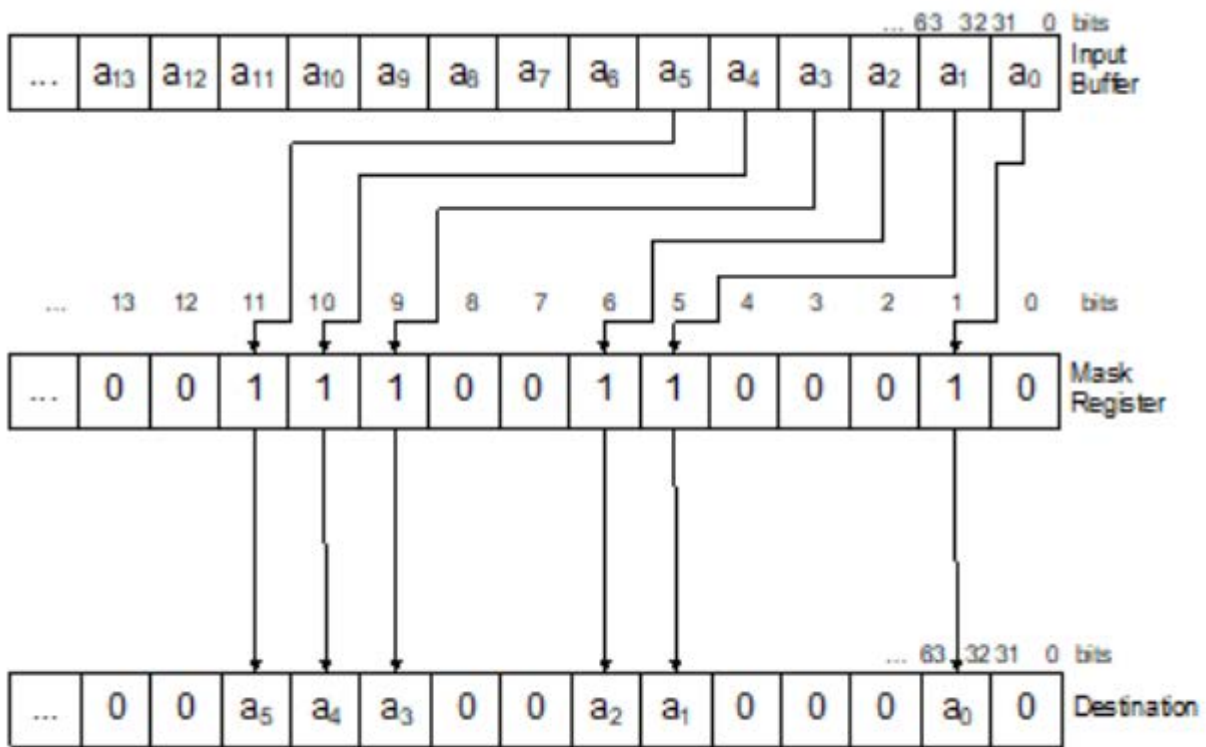

Figure 20-24. Data Expand Operation

Decompression code for 16-byte elements can be designed in the same manner.

For the best performance, apply the following optimizations:

- **Interleaving:** Fine-grained interleaving of decompression code and matrix multiplication to overlap Intel AVX-512 decompression with Intel AMX computation.
- **Decompress Early:** Prepare the decompressed buffer before immediate Intel AMX use to avoid store forwarding issues.
- **Buffer Reuse:** Decompressing the full sparse matrix could overflow the CPU caches. For best cache reuse, it is recommended to have a decompressed buffer that can hold two decompressed panels of the sparse matrix. While matrix is multiplying with one panel, decompress the next panel for the subsequent iteration. In the subsequent iteration, decompress the next panel into the first half of the decompressed buffer that is no longer used, and so on.
- **Decompress Once:** Coordinate the matrix multiplication blocking and loop structure with the decompression scheme to minimize the number of times the same portion of the sparse matrix is decompressed. For example, if matrix B is sparse, traversing the entire vertical (M) dimension will compress every vertical panel of the B matrix only once.

20.18 TILECONFIG/TILERELEASE, CORE C-STATE, AND COMPILER ABI

For a function to use Tile registers, it needs to configure them; see Section 20.2 for the LDTILECFG instruction definition. LDTILECFG creates an Intel® AMX state which is kept valid until the TILERELEASE instruction is issued. TILERELEASE resets the Intel AMX state back to INIT. When the Intel AMX state is valid, and the OS issues the MWAIT instruction trying to move the physical processor, it executes on to Core C6 State; the Sapphire Rapids SP processor does not enter Core C6, even if the sibling logical processor is idle, since it lacks the dedicated backing store to keep the Intel AMX state until waking up. The Core C-State is demoted to C1 instead.

This is not an issue in Linux and Windows where only the idle process issues the MWAIT instruction. The Idle Process in both operating systems does not use Intel AMX ISA, so its Intel AMX tile state is always invalid (INIT). The Intel AMX tile state is saved long ago in OS-defined save area in memory, if still valid, while context switching from a thread that uses Intel AMX to the Idle Process thread.

20.18.1 ABI

The tile data registers (tmm0 – tmm7) are volatile. Their contents are passed back and forth between functions through memory. No tile register is saved and restored by the callee. Tile configuration is also volatile. The compiler saves and restores tile configuration and tile register contents if the register(s) need to live across the function call. The compiler eliminates the save instruction because its content remains the same on the stack. The compiler reuses the configured content saved on the stack before the call. Any function needs to take care of the tile register configuration by itself. Tile registers may not be configured across functions.

Please download the System V Application Binary Interface: Intel386 Architecture Processor Supplement, Version 1.0.

20.18.2 INTRINSICS

Example 20-28. The Parameter m, n, k Identifies the Shape of the Tile

```
typedef int _tile1024i __attribute__((__vector_size__(1024), __aligned__(64)));
_tile1024i _tile_loadd_internal(unsigned short m, unsigned short n, const void*base, __SIZE_TYPE__ stride);
_tile1024i _tile_loaddt1_internal(unsigned short m, unsigned short n, const void*base, __SIZE_TYPE__ stride);
_tile1024i _tile_dpbsd_internal(unsigned short m, unsigned short n, unsigned short k, _tile1024i dst, _tile1024i
src1, _tile1024i src2);
_tile1024i _tile_dpbsud_internal(unsigned short m, unsigned short n, unsigned short k, _tile1024i dst, _tile1024i
src1, _tile1024i src2);
_tile1024i _tile_dpbusd_internal(unsigned short m, unsigned short n, unsigned short k, _tile1024i dst, _tile1024i
src1, _tile1024i src2);
_tile1024i _tile_dpbuud_internal(unsigned short m, unsigned short n, unsigned short k, _tile1024i dst, _tile1024i
src1, _tile1024i src2);
_tile1024i _tile_dpbf16ps_internal(unsigned short m, unsigned short n, unsigned short k, _tile1024i dst, _tile1024i
src1, _tile1024i src2);
void _tile_stored_internal(unsigned short m, unsigned short n, void*base, __SIZE_TYPE__ stride, _tile1024i tile);
```

The parameter m, n, k identifies the shape of the tile.

20.18.3 USER INTERFACE

Example 20-29. Intel® AMX Intrinsic header file

```

/* 1 of 3 */
typedef struct __tile1024i_str {
    const unsigned short row;
    const unsigned short col;
    __tile1024i tile;
} __tile1024i;

/// Load tile rows from memory specified by "base" address and "stride" into
/// destination tile "dst".
///
/// \headerfile <immintrin.h>
///
/// This intrinsic corresponds to the <c> TILELOADD </c> instruction.
///
/// \param dst
/// A destination tile. Max size is 1024 Bytes.
/// \param base
/// A pointer to base address.
/// \param stride
/// The stride between the rows' data to be loaded in memory.
void __tile_loadd(__tile1024i *dst, const void *base, __SIZE_TYPE__ stride);
/// Load tile rows from memory specified by "base" address and "stride" into
/// destination tile "dst". This intrinsic provides a hint to the implementation
/// that the data will likely not be reused in the near future and the data
/// caching can be optimized accordingly.
///
/// \headerfile <immintrin.h>
///
/// This intrinsic corresponds to the <c> TILELOADDT1 </c> instruction.
///
/// \param dst
/// A destination tile. Max size is 1024 Bytes.
/// \param base
/// A pointer to base address.
/// \param stride
/// The stride between the rows' data to be loaded in memory.
void __tile_stream_loadd(__tile1024i* dst, const void* base, __SIZE_TYPE__ stride);
/// Compute dot-product of bytes in tiles with a source/destination accumulator.
/// Multiply groups of 4 adjacent pairs of signed 8-bit integers in src0 with
/// corresponding signed 8-bit integers in src1, producing 4 intermediate 32-bit
/// results. Sum these 4 results with the corresponding 32-bit integer in "dst",
/// and store the 32-bit result back to tile "dst".
///
/// \headerfile <immintrin.h>
///

```

```

/* 2 of 3 */
/// This intrinsic corresponds to the <c> TDPBSSD </c> instruction.
///
/// \param dst
/// The destination tile. Max size is 1024 Bytes.
/// \param src0
/// The 1st source tile. Max size is 1024 Bytes.
/// \param src1
/// The 2nd source tile. Max size is 1024 Bytes.
void __tile_dpbsd(__tile1024i *dst, __tile1024i src1, __tile1024i src2);
/// Compute dot-product of bytes in tiles with a source/destination accumulator.
/// Multiply groups of 4 adjacent pairs of signed 8-bit integers in src0 with
/// corresponding unsigned 8-bit integers in src1, producing 4 intermediate
/// 32-bit results. Sum these 4 results with the corresponding 32-bit integer
/// in "dst", and store the 32-bit result back to tile "dst".
///
/// \headerfile <immintrin.h>
///
/// This intrinsic corresponds to the <c> TDPBSUD </c> instruction.
///
/// \param dst
/// The destination tile. Max size is 1024 Bytes.
/// \param src0
/// The 1st source tile. Max size is 1024 Bytes.
/// \param src1
/// The 2nd source tile. Max size is 1024 Bytes.
void __tile_dpbsd(__tile1024i *dst, __tile1024i src1, __tile1024i src2);
/// Compute dot-product of bytes in tiles with a source/destination accumulator.
/// Multiply groups of 4 adjacent pairs of unsigned 8-bit integers in src0 with
/// corresponding signed 8-bit integers in src1, producing 4 intermediate 32-bit
/// results. Sum these 4 results with the corresponding 32-bit integer in "dst",
/// and store the 32-bit result back to tile "dst".
///
/// \headerfile <immintrin.h>
///
/// This intrinsic corresponds to the <c> TDPBUUD </c> instruction.
///
/// \param dst
/// The destination tile. Max size is 1024 Bytes.
/// \param src0
/// The 1st source tile. Max size is 1024 Bytes.
/// \param src1
/// The 2nd source tile. Max size is 1024 Bytes.
void __tile_dpbuud(__tile1024i *dst, __tile1024i src1, __tile1024i src2);
/// Zero the tile specified by "dst".
///
/// \headerfile <immintrin.h>
///

```

```

/* 3 of 3 */
/// This intrinsic corresponds to the <c> TILEZERO </c> instruction.
///
/// \param dst
/// The destination tile to be zero. Max size is 1024 Bytes.
void __tile_zero(__tile1024i* dst);
/// Compute dot-product of BF16 (16-bit) floating-point pairs in tiles src0 and
/// src1, accumulating the intermediate single-precision (32-bit) floating-point
/// elements with elements in "dst", and store the 32-bit result back to tile
/// "dst".
///
///
/// \headerfile <immintrin.h>
///
/// This intrinsic corresponds to the <c> TDPBF16PS </c> instruction.
///// \param dst
/// The destination tile. Max size is 1024 Bytes.
/// \param src0
/// The 1st source tile. Max size is 1024 Bytes.
/// \param src1
/// The 2nd source tile. Max size is 1024 Bytes.
void __tile_dpbf16ps(__tile1024i* dst, __tile1024i src0, __tile1024i src1);
/// Store the tile specified by "src" to memory specified by "base" address and
/// "stride".
///
///
/// \headerfile <immintrin.h>
///
/// This intrinsic corresponds to the <c> TILESTORED </c> instruction.
///
/// \param dst
/// A destination tile. Max size is 1024 Bytes.
/// \param base
/// A pointer to base address.
/// \param stride
/// The stride between the rows' data to be stored in memory.
void __tile_stored(void *base, __SIZE_TYPE__ stride, __tile1024i src);

```

20.18.4 EXAMPLE

In Example 20-30, function `foo` is called in line 18, and the tile variable `'a'` written in line 17 needs to live up to line 21 across the function call. The compiler needs to save the tile data register allocated to `'a'` before calling `foo` and restore the tile configure register and tile data registers after calling `foo`. Lines 39, 42, and 46 in Figure 17-2 are the save/restore code. Since the configure register doesn't change, the configure register in the stack does not need to be saved.

Notice the `ldtilecfg` instruction at the beginning of the function (line 34 in Example 20-31), which sets the Intel AMX registers configuration within the CPU, and the `TileRelease` instruction towards the end of the function, which ensures that the Intel AMX state is initialized, thus avoiding the expensive Intel AMX state save/restore in case of software thread context switch outside of the Intel AMX function.

Example 20-30. Intel® AMX Intrinsic usage

```
1 #include <immintrin.h>
2
3 char buf[1024];
4 #define STRIDE 32
5
6 int count = 0;
7 __attribute__((noinline))
8 void foo() {
9     count++;
10 }
11
12 void test_api(int cond, unsigned short row, unsigned short col) {
13     __tile1024i a = {row, col};
14     __tile1024i b = {row, col};
15     __tile1024i c = {row, col};
16
17     __tile_loadd(&a, buf, STRIDE);
18     foo();
19     __tile_loadd(&b, buf, STRIDE);
20     __tile_loadd(&c, buf, STRIDE);
21     __tile_dpssd(&c, a, b);
22     __tile_stored(buf, STRIDE, c);
23 }
```

```
clang -O2 -S amx-across-func.c -mamx-int8 -mavx512f -fno-asynchronous-unwind-tables.
```

Example 20-31. Compiler-generated assembly-level code out of example 20-30 Intrinsic code

```

16 test_api:                #@test_api
17 # %bb.0:                 # %entry
18   pushq %rbp
19   pushq %r15
20   pushq %r14
21   pushq %rbx
22   subq $1096,%rsp        # imm = 0x448
23   movl %edx,%ebx
24   movl %esi,%ebp
25   vpxord %zmm0,%zmm0,%zmm0
26   vmovdqu64 %zmm0,(%rsp)
27   movb $1,(%rsp)
28   movw %bx,20(%rsp)
29   movb %bpl,50(%rsp)
30   movw %bx,18(%rsp)
31   movb %bpl,49(%rsp)
32   movw %bx,16(%rsp)
33   movb %bpl,48(%rsp)
34   ldtilecfg (%rsp)
35   movl $buf,%r14d
36   movl $32,%r15d
37   tileload (%r14,%r15),%tmm0
38   movabsq $64,%rax
39   tilestore %tmm0,64(%rsp,%rax) # 1024-byte Folded Spill
40   vzeroupper
41   callq foo
42   ldtilecfg (%rsp)
43   tileload (%r14,%r15),%tmm0
44   tileload (%r14,%r15),%tmm1
45   movabsq $64,%rax
46   tileload 64(%rsp,%rax),%tmm2 # 1024-byte Folded Reload
47   tdpbssd %tmm0,%tmm2,%tmm1
48   tilestore %tmm1,(%r14,%r15)
49   addq $1096,%rsp        # imm = 0x448
50   popq %rbx
51   popq %r14
52   popq %r15
53   popq %rbp
54   tilerelease
55   retq

```

20.18.5 COMPILATION OPTION

The save/restore is sometimes unnecessary, e.g., when foo does not clobber any tile register. To avoid unnecessary save/restore, compile with “-mllvm -enable-ipra”, which does an IPO analysis to get the information on what physical registers are clobbered during the function call. Example 20-32 shows no tile register save/restore across calling foo.

```
clang -O2 -S amx-across-func.c -mamx-int8 -mavx512f -fno-asynchronous-unwind-tables -mllvm -enable-ipra
```

Example 20-32. Compiler-generated assembly-level code where tile register save/restore is optimized away

```

15  .type test_api,@function
16 test_api:          #@test_api
17 # %bb.0:           # %entry
18  subq  $72,%rsp
19  vpxord %zmm0,%zmm0,%zmm0
20  vmovdqu64 %zmm0,8(%rsp)
21  movb  $1,8(%rsp)
22  movw  %dx,28(%rsp)
23  movb  %sil,58(%rsp)
24  movw  %dx,26(%rsp)
25  movb  %sil,57(%rsp)
26  movw  %dx,24(%rsp)
27  movb  %sil,56(%rsp)
28  ldtilecfg 8(%rsp)
29  movl  $buf,%eax
30  movl  $32,%ecx
31  tileload (%rax,%rcx),%tmm0
32  callq foo
33  tileload (%rax,%rcx),%tmm1
34  tileload (%rax,%rcx),%tmm2
35  tdpbssd %tmm1,%tmm0,%tmm2
36  tilestore %tmm2,(%rax,%rcx)
37  addq  $72,%rsp
38  tilerelease
39  vzeroupper
40  retq
41 .Lfunc_end1:
42  .size test_api,.Lfunc_end1-test_api

```

20.19 INTEL® AMX STATE MANAGEMENT

Intel AMX is XSAVE supported, meaning that it defines processor registers that can be saved and restored using instructions of the XSAVE feature set. Intel AMX is also XSAVE enabled, meaning that system software must enable it before it can be used.

The XSAVE feature set operates on state components, each a discrete set of processor registers (or parts of registers). Intel AMX is associated with two state components, XTILECFG and XTILEDATA. The XSAVE feature set organizes state components using state-component bitmaps. A state-component bitmap comprises 64 bits; each bit in such a bitmap corresponds to a single state component. Intel AMX defines bits 18:17 for its state components (collectively, these are called AMX state):

- State component 17 is used for the 64-byte TILECFG register (XTILECFG state).
- State component 18 is used for the 8192 bytes of tile data (XTILEDATA state).

These are both user state components, meaning the entire XSAVE feature set can manage them. In addition, it implies that setting bits 18:17 of extended control register XCR0 by system software enables Intel AMX. If those bits are zero, an Intel AMX instruction execution results in an invalid-opcode exception (#UD).

About the XSAVE feature set's INIT optimization, the Intel AMX state is in its initial configuration if the TILECFG register is zero and all tile data are zero.

The enumeration and feature enabling documentation can be found in the Intel AMX Architecture Definition; see Section 20.2.

An execution of XRSTOR or XRSTORS initializes the TILECFG register (resulting in TILES_CONFIGURED = 0) in response to an attempt to load it with an illegal value. Moreover, an execution of XRSTOR or XRSTORS that is not directed to load XTILEDATA leaves it unmodified, even if the execution is loading XTILECFG.

It is highly recommended that developers execute TILERELASE to initialize the tiles at the end of the AMX instructions code region. More on this is in Section .

System software may disable the use of Intel AMX by clearing XCR0[18:17] by clearing CR4.OSXSAVE, or by setting IA32_XFD[18]. It is recommended that system software initializes the AMX state (e.g., by executing TILERELASE) before doing so.

20.19.1 EXTENDED FEATURE DISABLE (XFD)

The XTILEDATA state component size is 8 KBytes, and an operating system may prefer not to allocate memory for the XTILEDATA state by default for every user thread. Such an operating system that enables Intel AMX might select a fault when user threads use the feature. That way, the operating system can allocate a large enough state save area only for the user threads that use the feature. An operating system may offer an API for the user threads to declare their intention to use Intel AMX and allow the OS to pre-allocate the state and avoid an exception when Intel AMX is used for the first time. See <https://www.kernel.org/doc/html/latest/x86/xstate.html> for Linux API and <https://learn.microsoft.com/en-us/windows/win32/api/winbase/> for Windows API

Extended feature disable (XFD) is added to the XSAVE feature set to support such usage. XFD is documented in the Intel AMX Architecture Definition, see <https://www.intel.com/content/www/us/en/developer/technical-library/installation-guides.html>.

20.19.2 ALTERNATE SIGNAL HANDLER STACK IN LINUX OPERATING SYSTEM

When programs use an alternate signal handler stack, its size should be adjusted to accommodate the additional Intel AMX state. See <https://www.kernel.org/doc/html/latest/x86/xstate.html> for more details.

20.20 USING INTEL® AMX TO EMULATE HIGHER PRECISION GEMMS

AMX/TMUL has instructions that enable matrix-matrix operations such as multiplication on small precision elements. This section considers how to use the low-precision Intel AMX instructions to approximate the answers of matrix-matrix multiplication of higher-precision terms. Even if the low-precision inputs are Bfloat16 or Integer8, one can still combine the transforms to approximate matrix-matrix multiplication in higher precisions.

When approximating higher precision, pay attention to the exponent range and mantissa bits. There are IEEE-754 double precision numbers (FP64) that aren't representable as single precision (FP32) or lower precisions. These are typically range-based issues in the exponent bits. FP64 has more exponent bits than FP32. However, scaling factors can overcome most range-based problems. If A is a matrix of FP64 values, then A, as a sum of Bfloat16 matrices, cannot generally be represented; but scaling factors can be used to get around most issues. A as $s_1*A_1 + s_2*A_2 + \dots + s_n*A_n$ can be written where each matrix A_i is lower precision, and each s_i is a constant scaling factor.

For Bfloat16 decomposition of FP32, consider the following:

- Let A be a matrix of FP32 values
- Let $A_1 = \text{bfloat16}(A)$, a matrix containing RNE-rounded Bfloat16 conversions of A

- Let $A_2 = \text{bfloat16}(A - \text{fp32}(A_1))$
- Let $A_3 = \text{bfloat16}(A - \text{fp32}(A_1) - \text{fp32}(A_2))$
- Now A is approximately $A_1 + A_2 + A_3$.

Once one has written two matrices as a sum of lower precision matrices, one can run AMX/TMUL on the product to approximate the higher precision. But to do this effectively, one needs to have higher precision accumulation. There are tricks in the literature for doing higher precision all in a lower precision, such as works on so-called double-double arithmetic. Still, these tend to vary too much from standard matrix-matrix multiplication to be helpful with TMUL. In the case of Bfloat16, having 32-bit accumulation in the product allows one to use Bfloat16 to approximate FP32 accuracy.

Therefore, if $A = s_1*A_1 + s_2*A_2 + s_3*A_3$ and $B = t_1*B_1 + t_2*B_2 + t_3*B_3$, then $A*B$ can be computed using AMX/TMUL on the products A_i*B_j for $1 \leq i, j \leq 3$, assuming scaling is done carefully to avoid denormals. Assuming FP32 accumulation, the FP32 approximation of $A*B$ can be made by writing out these lower precision multiplies. Scaling factors can be chosen to avoid denormals at times, but they can also be picked in a way that simplifies further steps in the algorithm. In some cases, scaling factors can be chosen to be a power of two, for instance, without significantly reducing the accuracy of the resulting matrix-matrix multiply.

The number of matrices for A or B are picked depending on the mantissa range to cover. If trying to emulate FP32 which has 24 bits of mantissa (including the implicit mantissa bit), it is possible with 3 Bfloat16 matrices (because each of the triples has 8 bits of mantissa, including the implicit bit.). Here the range is less important because Bfloat16 and FP32 have the same exponent range. Use three Bfloat16 matrices to approximate FP32 precision by BF16x3. Range issues may still come up for BF16x3 cases where A has values close to the maximum or minimum exponent for FP32, but that too can be circumvented by scaling constants. Scaling factors of 2^{24} or 2^{-24} suffice to push it far enough away from the boundary to make the computation feasible again. This is dependent upon the closest end of the spectrum.

A few terms from an expansion can also be dropped. For instance, in the BF16x3 case, where there are three A s and three B s, nine products may result. That is:

$$A*B = (A_1+A_2+A_3)*(B_1+B_2+B_3) = (A_1*B_1) + (A_1*B_2 + A_2*B_1) + (A_1*B_3 + A_2*B_2 + A_3*B_1) + (A_2*B_3 + A_3*B_2) + (A_3*B_3).$$

The parentheses in the last equation are intentionally derived so that all entries in the same “bin” are put together, and there are nine entries of the form A_i*B_j . This example has five bins, each with its own set of parentheses. In the Bfloat16 case, $|A_i| \leq |A_{i-1}| / 256$. This shows the last two bins (with $A_2*B_3, A_3*B_2, A_3*B_3$) are too small to contribute significantly to the answer, which is why if there are Y terms on each side of $A*B$, only $(Y+1)*Y/2$ multiplies are required, not $Y*Y$ multiplies. In this case, dropping the last three (also the difference between $Y*Y - (Y+1)*Y/2$ when $Y=3$.) from the nine multiplies. The last three multiplies in the last two bins have terms less than 2^{-24} as big as the first term. So, $A*B$ can be approximated (ignoring the scaling terms for now) as the sum of the first three most significant bins: $A_1*B_1 + (A_1*B_2+A_2*B_1)+(A_1*B_3+A_2*B_2+A_3*B_1)$. In this case, adding from the least significant bin to the most significant bin (A_1*B_1) is recommended.

Whenever A and B are each expanded out to Y -terms, computing only $Y*(Y+1)/2$ products works under the condition that each term has the same number of mantissa bits. If some terms have a different number of bits, then this guideline no longer applies. But for BF16x3, each term covers eight mantissa bits and $Y=3$, so six products are needed.

Regarding accuracy, the worst-case relative error for BF16x3 may be worse than FP32. However, BF16x3 tends to cover a larger mantissa range due to implicit bits, which can be more accurate in many cases. Nevertheless, accuracy is not offered by matrix-matrix multiplication. Even FP64 or FP128 can be bad for component-wise relative errors. Take $A = [1, -1]$ and $B = [1; 1]$. $A*B$ is zero. Let ϵ be a small perturbation to A and/or B . The solution may now be arbitrarily bad in terms of relative error. In general, assume that the same mantissa range and exponent range is covered as a given higher-precision floating point format, and the accumulation is at least as good as the higher-precision format. With such an

assumption, the answer will be approximately the same as the higher-precision floating point format. It may or may not be identical. Performing the same operation in the higher precision format but changing the order of the computations could yield slightly different results. In terms of matrix-matrix multiplication, it could yield vast differences in relative error.

Things get slightly more complicated if low precision is used to approximate matrix-matrix at FP64 accuracy or FP128 precision. Here the scalars aren't just for avoiding denormals but are necessary to do the initial matrix conversion. Nevertheless, converting to an integer is recommended in this case because the FP32-rounded errors in each of the seven or fewer bins may introduce too many errors. An integer is easier to get right because there are no floating-point errors in each bin.

Conversion to Integer functions in the same way as all of the previous Bfloat16 examples. The quantization literature explains how to map floating point numbers into integers. The only difference is that these integers are further broken down into 8-bit pieces for the use of AMX. Constant factors are still needed, but in this case they are primarily defined in the conversion itself.

One difficulty with quantization to integers is the notion of a shared exponent. All the numbers quantized together with shared exponents must share the same range. The assumption is that all of A shares a joint exponent range. Since this will also be true for B, each row of A and column of B can be quantized separately.

Assuming that there is Integer32 accumulation with the Integer8 multiplies, a matrix may be broken down into far more bits than required. This may significantly reduce the inaccuracy impact of picking a shared exponent. Because Integer32 arithmetic will be precise, modulo overflow/underflow concerns, then one can break up A or B into a huge number of 8-bit integer matrices, then do all the matrix-matrix work with AMX, and then convert back all the results to even get accuracies up to quad-precision.

Considering an extreme case of trying to get over 100-bits of accuracy in a matrix-matrix multiply. All A-values can be quantified into 128-bit integers. The same holds true with B. Once broken down into 8-bit quantities, this will have a significant expansion like: $A = s_1*A_1 + s_2*A_2 + \dots + s_{14}*A_{14}$ for when attempting 112-bits of mantissa. The same can be done with $B = t_1*B_1 + t_2*B_2 + \dots + t_{14}*B_{14}$. $A*B$ is potentially $14*14=196$ products, but only 105 products are needed because the last few products may have scaling factors less than $2^{(-112)}$ times the most important terms. Each product term should be added separately and computing into C from the least significant bits forward.

$$C_{15} = (s_1*t_{14})*A_1*B_{14} + (s_2*t_{13})*A_2*B_{13} + \dots + (s_{14}*t_1)*A_{14}*B_1$$

$$C_{14} = (s_1*t_{13})*A_1*B_{13} + (s_2*t_{12})*A_2*B_{12} + \dots + (s_{13}*t_1)*A_{13}*B_1$$

$$C_{13} = (s_1*t_{12})*A_1*B_{12} + (s_2*t_{11})*A_2*B_{11} + \dots + (s_{12}*t_1)*A_{12}*B_1$$

...

$$C_{02} = (s_1*t_1)*A_1*B_1$$

Sometimes choosing scalars is possible such that all the products in a given row can be computed with the same scratch array. The converted sum of C02 gives the final product through C15, where terms like C15 should be computed first.

Writing matrix-matrix multiplies in terms of an expansion like $(A_1+A_2+A_3)*(B_1+B_2+B_3)$ is referred to as "cascading GEMM." Performance will vary depending on the TMUL/AMX specification, and may vary from generation to generation. Note that some computations may become bandwidth-bound. Since there is no quad floating-point precision in hardware for Intel Architecture, the above algorithm may be competitive performance-wise with other approaches like doing software double-double optimizations or software-based quad precision.

CHAPTER 21

CRYPTOGRAPHY & FINITE FIELD ARITHMETIC ENHANCEMENTS

Several instruction extensions designated for acceleration of cryptography flows and finite field arithmetic are available, beginning with the Ice Lake Client microarchitecture. The ISA extensions include Vector AES, VPCLMULQDQ, Galois Field New Instructions (GFNI), and AVX512_IMFA, also known as VPMADD52. The following sections describe these extensions and provide examples and simple comparisons to previous implementation code.

See the *Intel® 64 and IA-32 Architectures Software Developer's Manual* for the complete instruction definitions.

Intel implements support for the most common cryptography algorithms, supporting main public libraries and commonly used software. The following sections describe the instructions briefly. For further details on the proper usages of the new instructions with an exploration of their applications on the system, refer to the following paper: <http://goto.intel.com/cryptowp>.

21.1 VECTOR AES

The Vector AES extension supports the vectorization of the previously announced Intel® Advanced Encryption Standard New Instructions (Intel® AES-NI)¹. The new instructions support parallel execution for up to four blocks of input within a single instruction. The extended ISA, namely VAESENC, VAESENCLAST, VAESDEC, and VAESDECLAST, are intended for performance acceleration of the relevant AES mode of operations and multi-buffer implementations. The new instructions accelerate AES modes by up to 3.3x compared to previous code supported by Intel AES-NI.

Below is a snippet of AES-ECB mode of operation code, implemented on AT-T Assembly, emphasizing the legacy Intel AES-NI vs. Vector AES.

Example 21-1. Legacy Intel® AES-NI vs. Vector AES

Legacy Intel® AES-NI - AES ECB Encryption	Vector AES - AES ECB Encryption
<pre>// rcx = pointer to Key Expansion movdqa 16*1(%rcx), %xmm9 // xmm1 - xmm8 - 8 blocks of AES // 1st round of AES for 8 blocks aesenc %xmm9, %xmm1 aesenc %xmm9, %xmm2 aesenc %xmm9, %xmm3 aesenc %xmm9, %xmm4 aesenc %xmm9, %xmm5 aesenc %xmm9, %xmm6 aesenc %xmm9, %xmm7 aesenc %xmm9, %xmm8 movdqa 16*2(%rcx), %xmm9</pre>	<pre>// rcx = pointer to Key Expansion // broadcasting key to zmm0 vbroadcasti64x2 1*16(%rcx), %zmm0 // 1st round of AES for 8 blocks vaesenc %zmm0, %zmm1, %zmm1 vaesenc %zmm0, %zmm2, %zmm2 vbroadcasti64x2 2*16(%rcx), %zmm0 // 2nd Round of AES for 8 Blocks vaesenc %zmm0, %zmm1, %zmm1 vaesenc %zmm0, %zmm2, %zmm2</pre>

1. <https://www.intel.com/content/dam/doc/white-paper/advanced-encryption-standard-new-instructions-set-paper.pdf>

Example 21-1. Legacy Intel® AES-NI vs. Vector AES (Contd.)

<pre>// 2nd Round of AES for 8 Blocks aesenc %xmm9, %xmm1 aesenc %xmm9, %xmm2 aesenc %xmm9, %xmm3 aesenc %xmm9, %xmm4 aesenc %xmm9, %xmm5 aesenc %xmm9, %xmm6 aesenc %xmm9, %xmm7 aesenc %xmm9, %xmm8</pre>	
Baseline: 1x	Speedup: 3.3x

The code above demonstrates the ability of implementing AES in ECB mode of operation, using 8 parallel buffers, implemented on legacy vs. Vector AES. The same acceleration can be applied to other modes of operation, such as AES-CTR and AES-CBC, and also to more elaborate schemes such as AES-GCM. The latter one requires fast computations of a hash function, namely GHASH, which can be accelerated using the VPCLMULQDQ new instruction, which is described in Section 21.2.

21.2 VPCLMULQDQ

Carry-less multiplication, namely PCLMULQDQ, was previously introduced on the Intel® Core™ processor family based on Westmere microarchitecture¹. In newer architectures, beginning with Ice Lake Client microarchitecture, Intel introduces the vectorization of PCLMULQDQ, namely VPCLMULQDQ, supporting acceleration of up to 4x compared to its legacy. The new instruction is used for polynomial multiplication over binary fields used on current cryptography algorithms such as AES-GCM. The new instruction may also be useful for the upcoming Post-Quantum Cryptography project submissions, used for BIKE and others. Such usages emphasizes the importance of the current use of VPCLMULQDQ. A common use case for using the instruction can be seen on GHASH computation, with four different carry-less multiplications done within a single instruction, using the wide 512-bit registers. This use case elaborates the performance of AES-GCM, which is the main mode of operation used on AES.

21.3 GALOIS FIELD NEW INSTRUCTIONS

Galois Field new instructions are recently introduced in newer architecture, beginning with Ice Lake Client microarchitecture. The new instructions, namely VGF2P8MULB, VGF2P8AFFINEQB, and VGF2P8AFFINEINVQB, allow software flows to perform vector and matrix multiplications over $GF(2^8)$ on the Intel AVX512 architectural registers. The wide usages of these instructions vary from Reed-Solomon code implementation, to different encryption schemes such as the Chinese encryption scheme - SM4 and others.

1. <https://software.intel.com/en-us/articles/intel-carry-less-multiplication-instruction-and-its-usage-for-computing-the-gcm-mode>

Example 21-2. SM4 GFNI Encryption Round Example

```

.LAFFINE_IN:
.byte 0x52,0xBC,0x2D,0x02,0x9E,0x25,0xAC,0x34,0x52,0xBC,0x2D,0x02,0x9E,0x25,0xAC,0x34
.byte 0x52,0xBC,0x2D,0x02,0x9E,0x25,0xAC,0x34,0x52,0xBC,0x2D,0x02,0x9E,0x25,0xAC,0x34
.byte 0x52,0xBC,0x2D,0x02,0x9E,0x25,0xAC,0x34,0x52,0xBC,0x2D,0x02,0x9E,0x25,0xAC,0x34
.byte 0x52,0xBC,0x2D,0x02,0x9E,0x25,0xAC,0x34,0x52,0xBC,0x2D,0x02,0x9E,0x25,0xAC,0x34

.LAFFINE_OUT:
.byte 0x19,0x8b,0x6c,0x1e,0x51,0x8e,0x2d,0xd7,0x19,0x8b,0x6c,0x1e,0x51,0x8e,0x2d,0xd7
.byte 0x19,0x8b,0x6c,0x1e,0x51,0x8e,0x2d,0xd7,0x19,0x8b,0x6c,0x1e,0x51,0x8e,0x2d,0xd7
.byte 0x19,0x8b,0x6c,0x1e,0x51,0x8e,0x2d,0xd7,0x19,0x8b,0x6c,0x1e,0x51,0x8e,0x2d,0xd7
.byte 0x19,0x8b,0x6c,0x1e,0x51,0x8e,0x2d,0xd7,0x19,0x8b,0x6c,0x1e,0x51,0x8e,0x2d,0xd7
.globl SM4_ENC_ECB_AVX512_GFNI
SM4_ENC_ECB_AVX512_GFNI:
vmovdqa64 .LAFFINE_IN(%rip), %zmm10
vmovdqa64 .LAFFINE_OUT(%rip), %zmm11
...
/* Load data swapped LE-BE in transposed way - each block's double word is found on
different AVX512 register
*/

.Rounds:
// Initial xor between the 2nd, 3rd, 4th double word to key
vpbroadcastd 4*(key), %zmm6
vpternlogd $0x96, %zmm1, %zmm2, %zmm3
vpxorq %zmm3, %zmm6, %zmm6
/* Sbox phase */
vgf2p8affineqb $0x65, %zmm10, %zmm6, %zmm6
vgf2p8affineinvqb $0xd3, %zmm11, %zmm6, %zmm6
/* Done Sbox , Linear rotations start xor with 1st double word input*/
vprold $2, %zmm6, %zmm12
vprold $10, %zmm6, %zmm13
vprold $18, %zmm6, %zmm7
vprold $24, %zmm6, %zmm14
vpternlogd $0x96, %zmm6, %zmm12, %zmm0
vpternlogd $0x96, %zmm13, %zmm7, %zmm14
vpxord %zmm14, %zmm0, %zmm0
/* Linear part done - round complete */

```

21.4 INTEGER FUSED MULTIPLY ACCUMULATE OPERATIONS (AVX512_IFMA - VPMADD52)

Beginning with Ice Lake Client microarchitecture, Intel introduces AVX512_IFMA, namely VPMADD52. The new instructions, VPMADD52LUQ and VPMADD52HUQ, multiply 8x52-bit unsigned integers found in the 512-bit wide registers, produce the high and low halves of the result, and add to the 64-bit accumulators. The instructions are designated for big number multiplication, assuming the inputs are using radix 252. The new instructions can be used for accelerating modular exponent computation code, which is widely used on RSA. Code usages can be already seen on OpenSSL¹.

1. <https://www.openssl.org/>

The Intel® QuickAssist Technology API supports two acceleration services:

- Cryptographic
- Data Compression.

The acceleration driver interfaces with the hardware via hardware-assisted rings. These rings are used as request and response rings. The driver uses request rings to submit requests to the accelerator and response rings to retrieve responses from the accelerator. The availability of responses can be indicated to the driver using either interrupts or by having software poll the response rings.

At the Intel® QuickAssist Technology API, services are accessed via “instances.” A set of rings is assigned to an instance, and any operations performed on a service instance will involve communication over the rings assigned to that instance.

22.1 SOFTWARE DESIGN GUIDELINES

Key design decisions should be considered to achieve optimal performance when integrating with the Intel QuickAssist Technology software. In many cases, the best Intel® QuickAssist Technology configuration is dependent on the design of the application stack that is being used. Therefore, it is impossible to have a “one configuration fits all” approach. The trade-offs between different approaches will be discussed in this section to help the designer make informed decisions.

These guidelines focus on the following performance aspects:

- Maximizing throughput through the accelerator
- Minimizing the offload cost incurred when using the accelerator
- Minimizing latency

Each guideline will highlight its impact on performance. This document does not give specific performance numbers since exact performance numbers depend on various factors and tend to be specific to a given workload, software, and platform configuration. Further, such numbers tend to be specific to a given workload, software, and platform configuration.

22.1.1 Polling vs. Interrupts (If Supported)

NOTE

Not all use cases support interrupt mode, and not all software packages support interrupt mode.

Software can either periodically query the hardware accelerator for responses or enable the generation of an interrupt when responses are available. Interrupts or polling mode can be configured per instance via the platform-specific configuration settings.

The properties and performance characteristics of each mode are explained below followed by recommendations on selecting a configuration.

22.1.1.1 Interrupt Mode

When operating in interrupt mode, the accelerator will generate an MSI-X interrupt when a response is placed on a response ring. Each ring bank has a separate MSI-X interrupt which may be steered to a particular CPU core via the CoreAffinity settings in the configuration file.

To reduce the number of interrupts generated, and hence the number of CPU cycles spent processing interrupts, multiple responses can coalesce together. The presence of the multiple responses can be indicated via a single coalesced interrupt rather than having an interrupt per response. An interrupt coalescing timer determines the number of responses associated with a coalesced interrupt. When the accelerator places a response in a response ring, it starts an interrupt coalescing timer. While the timer runs, additional responses may be placed in the response ring. When the timer expires, an interrupt is generated to indicate that responses are available.

Since interrupt coalescing is based on a timer, there is some variability in the number of responses associated with an interrupt. The arrival rate of responses is a function of the arrival rate of the associated requests and of the request size. Hence, the timer configuration needed to coalesce X large requests differs from the timer configuration needed to coalesce X small requests. Tuning the timer based on the average expected request size is recommended.

The choice of timer configuration impacts throughput, latency, and offload cost:

- Configuring a very short time period maximizes the throughput through the accelerator, minimizing latency, but will increase the offload cost since there will be a higher number of interrupts and hence more CPU cycles spent processing the interrupts. If this interrupt processing becomes a performance bottleneck for the CPU, the overall system throughput will be impacted.
- Configuring a very long timer period leads to reduced offload cost (due to the reduction in the number of interrupts) but increased latency. If the timer period is very long and causes the response rings to fill, the accelerator will stall, and throughput will be impacted.

The appropriate coalescing timer configuration will depend on the characteristics of the application. It is recommended that the value chosen is tuned to achieve optimal performance.

Using interrupts to notify user-space applications is achieved using “epoll mode,” which utilizes the kernel device drivers poll function to allow an application to get notified of interrupt events.

Because epoll mode has two parts, of which the kernel space part utilizes the interrupts, if there is a delay in the kernel interrupt (for example, by changing the coalescing fields), there will be a corresponding increase in latency in the delivery of the event to user space.

The thread waiting for an event in epoll mode does not consume CPU time, but the latency could impact performance. For higher packet load where the wait time for the next packet is insignificant, polling mode is recommended.

When using interrupts with the user space Intel QuickAssist Technology driver, there is significant overhead in propagating the interrupt to the user space process that the driver is running in. This leads to an increased offload cost. Hence, interrupts should not be used with the user-space Intel QuickAssist Technology driver.

22.1.1.2 Polling Mode

In polled mode, interrupts are fully disabled and the software application must periodically invoke the polling API, provided by the Intel® QuickAssist Technology driver, to check for and process responses from the hardware.

The frequency of polling is a key performance parameter that should be fine-tuned based on the application. This parameter has an impact on throughput, latency, and on offload cost:

- If the polling frequency is too high, CPU cycles are wasted if no responses are available when the polling routine is called. This leads to an increased offload cost.
- If the polling frequency is too low, latency is increased and throughput may be impacted if the response rings fill causing the accelerator to stall.

The choice of threading model has an impact on performance when using a polling approach. There are two main threading approaches when polling:

- Creating a polling thread that periodically calls the polling API. This model is often the simplest to implement, allows for maximum throughput, but can lead to increased offload cost due to the overhead associated with context switching to/from the polling thread.

- Invoking the polling API and submitting new requests from within the same thread. This model is characterized by having a “dispatch loop” that alternates between submitting new requests and polling for responses. Additional steps are often included in the loop such as checking for received network packets or transmitting network packets. This approach often leads to the best performance since the polling rate can be easily tuned to match the submission rate so throughput is maximized and offload cost is minimized.

22.1.1.3 Recommendations

Polling mode tends to be preferred in cases where traffic is steady (like packet processing applications) and can result in a minimal offload cost. Epoll mode is preferred for cases where traffic is bursty, as the application can sleep until there is a response to process.

Considerations when using polling mode:

- Fine-tuning the polling interval is critical to achieving optimal performance.
- The preference is for invoking the polling API and submitting new requests from within the same thread rather than having a separate polling thread.

Considerations when using epoll mode:

- CPU usage will be at 0% in idle state in epoll mode versus a non-zero value in standard poll mode. However, with a high load state, standard poll mode should out-perform epoll mode.

22.1.2 Use of Data Plane (DP) API vs. Traditional API

The cryptographic and compression services provide two flavors of API, known as the traditional API and the Data Plane API. The traditional API provides a full set of functionality including thread safety that allows many application threads to submit operations to the same service instance. The Data Plane API is aimed at reducing offload cost by providing a “bare bones” API, with a set of constraints, which may suit many applications. Refer to the Intel QuickAssist Technology Cryptographic API Reference Manual for more details on the differences between the DP and traditional APIs for the crypto service.

From a throughput and latency perspective, there is no difference in performance between the Data Plane API and the traditional API.

From an offload cost perspective, the Data Plane API uses significantly fewer CPU cycles per request compared to the traditional API. For example, the cryptographic Data Plane API has an offload cost that is lower than the cryptographic traditional API.

22.1.2.1 Batch Submission of Requests Using the Data Plane API

The Data Plane API provides the capability to submit batches of requests to the accelerator. The use of the batch mode of operation leads to a reduction in the offload cost compared to submitting the requests one at a time to the accelerator. This is due to CPU cycle savings arising from fewer writes to the hardware ring registers in PCIe* memory space. However, it is important to note that optimized batch size may be different, depending on the application.

Using the Data Plane API, batches of requests can be submitted to the accelerator using either the `cpaCySymDpEnqueueOp()` or `cpaCySymDpEnqueueOpBatch()` API calls for the symmetric cryptographic data plane API and using either the `cpaDcDpEnqueueOp()` or

`cpaDcDpEnqueueOpBatch()` API calls for the compression data plane API. In all cases, requests are only submitted to the accelerator when the `performOpNow` parameter is set to `CPA_TRUE`.

It is recommended to use the batch submission mode of operation where possible to reduce offload cost.

22.1.3 Synchronous (sync) vs. Asynchronous (async)

The Intel QuickAssist Technology traditional API supports both synchronous and asynchronous modes of operation. The Intel QuickAssist Technology Data Plane API only supports the asynchronous mode of operation.

With synchronous mode, the traditional Intel QuickAssist Technology API will block and not return to the calling code until the acceleration operation has completed.

With asynchronous mode, the traditional or Data Plane Intel QuickAssist Technology API will return to the calling code once the request has been submitted to the accelerator. When the accelerator has completed the operation, the completion is signaled via the invocation of a callback function.

From a performance perspective, the accelerator requires multiple inflight requests per acceleration engine to achieve maximum throughput. With synchronous mode of operation, multiple threads must be used to ensure that multiple requests are inflight. The use of multiple threads introduces an overhead of context switching between the threads which leads to an increase in offload cost.

Hence, the use of asynchronous mode is the recommended approach for optimal performance.

22.1.4 Buffer Lists

The symmetric cryptographic and compression Intel QuickAssist Technology APIs use buffer lists for passing data to/from the hardware accelerator. The number and size of elements in a buffer list has an impact on throughput; performance degrades as the number of elements in a buffer list increases. To minimize this degradation in throughput performance, it is recommended to keep the number of buffers in a buffer list to a minimum. Using a single buffer in a buffer list leads to optimal performance. See also 4.1.4 Payload Alignment for additional considerations.

NOTE

Specific performance numbers are not given in this document since exact performance numbers depend on a variety of factors and tend to be specific to a given workload, software and platform configuration.

When using the Data Plane API, it is possible to pass a flat buffer to the API instead of a buffer list. This is the most efficient usage of system resources (mainly PCIe bandwidth) and can lead to lower latencies compared to using buffer lists.

In summary, the recommendations for using buffer lists are:

- If using the Data Plane API, use a flat buffer instead of a buffer list.
- If using a buffer list, a single buffer per buffer list leads to highest throughput performance.
- If using a buffer list, keep the number of buffers in the list to a minimum.

22.1.5 Maximum Number of Concurrent Requests

The depth of the hardware rings used by the Intel QuickAssist Technology driver for submitting requests to, and retrieving responses from, the accelerator hardware can be controlled via the configuration file using the `CyXNumConcurrentSymRequests`, `CyXNumConcurrentAsymRequests` and `DcXNumConcurrentRequests` parameters. These settings can have an impact on performance:

- As the maximum number of concurrent requests is increased in the configuration file, the memory requirements required to support this also increases.
- If the number of concurrent requests is set too low, there may not be enough outstanding requests to keep the accelerator busy and throughput will degrade. The minimum number of concurrent requests required to keep the accelerator busy is a function of the size of the requests and of the rate at which responses are processed via either polling or interrupts (see Section 22.1.1 for additional details).
- If the number of concurrent requests is set too high, the maximum latency will increase.

It is recommended that the maximum number of concurrent requests is tuned to achieve the correct balance between memory usage, throughput and latency for a given application. As a guide the maximum number configured should reflect the peak request rate that the accelerator must handle.

22.1.6 Symmetric Crypto Partial Operations

The symmetric cryptographic Intel QuickAssist Technology API supports partial operations for some cryptographic algorithms. This allows a single payload to be processed in multiple fragments with each fragment corresponding to a partial operation. The Intel QuickAssist Technology API implementation will maintain sufficient state between each partial operation to allow a subsequent partial operation for the same session to continue from where the previous operation finished.

From a performance perspective, the cost of maintaining the state and the serialization between the partial requests in a session has a negative impact on offload cost and throughput. To maximize performance when using partial operations, multiple symmetric cryptographic sessions must be used to ensure that sufficient requests are provided to the hardware to keep it busy.

For optimal performance, it is recommended to avoid the use of partial requests if possible.

There are some situations where the use of partials cannot be avoided since the use of partials and the need to maintain state is inherent in the higher level protocol (such as, the use of the RC4 cipher with an SSL/TLS protocol stack).

22.1.7 Reusing Sessions in QAT Environment

The session is the entry point to perform symmetric cryptography with the QAT device. Every session has assigned algorithm, state, instance, but also allocated memory space.

When limited the number of instances and want to run several different algorithms or change keys for another session, de-initialize the session and create a new one. However, such an approach impacts performance because it involves buffer disposal, deinitialization of the instance, etc..

Instead, the session can be reused with updating only a direction (encryption / decryption), key or symmetric algorithm to be used. This method will not dispose buffers and can reduce the CPU cycles significantly.

22.1.8 Maximizing QAT Device Utilization

The Intel QuickAssist device utilization and throughput are maximized when there are sufficient requests outstanding to occupy the multiple internal acceleration engines with the device.

Assigning each Intel QuickAssist service instance to a separate CPU core to balance the load across the CPU is recommended to ensure that there are sufficient CPU cycles to drive the accelerators at maximum performance. In a CPU with sufficiently high frequency, multiple instances may share the same CPU core.

When using interrupts, the core affinity settings within the configuration file should be used to steer the interrupts for a service instance to the appropriate core.

22.1.9 Best Known Method (BKM) for Avoiding Performance Bottlenecks

For optimal performance, ensure the following:

- All data buffers should be aligned on a 64-byte boundary.
- Transfer sizes that are multiples of 64 bytes are optimal.
- Small data transfers (less than 64 bytes) should be avoided. If a small data transfer is needed, consider embedding this within a larger buffer so that the transfer size is a multiple of 64 bytes. Offsets can then be used to identify the region of interest within the larger buffer.
- Each buffer entry within a Scatter-Gather-List (SGL) should be a multiple of 64bytes and should be aligned on a 64-byte boundary.

22.1.10 Avoid Data Copies By Using SVM and ATS

On CPUs and Intel QuickAssist devices that support shared virtual memory (SVM), virtual addresses to virtually contiguous buffers can be supplied to the Intel QAT hardware. Without this support, physical addresses to physically contiguous and DMAable memory buffers must be used. Using virtual addressed memory avoids the need to copy payload data from user space memory allocated with `malloc()` to physically contiguous memory.

When SVM is enabled, the Intel QuickAssist device interacts with the IOMMU to fetch the virtual to physical address translations when accessing memory and this can result in increased latency and lower throughput.

22.1.11 Avoid Page Faults When Using SVM

When using SVM to avoid data copies, there is a chance that after a request, that refers to a virtually addressed buffer, has been submitted to the Intel QuickAssist device, the operating system may swap out the memory pages associated with that buffer. This will result in a page fault when the Intel QAT device tries to access the memory. The Intel QAT device will stall the processing of that request until the page fault is resolved or times out. This can lead to an underutilization of the Intel QAT device. To avoid page faults, the memory submitted to QAT should be pinned.

CHAPTER 23

KNIGHTS LANDING MICROARCHITECTURE AND SOFTWARE OPTIMIZATION

Intel® Xeon Phi™ Processors 7200/5200/3200 Series are based on the Knights Landing microarchitecture. Coding techniques for software targeting the Knights Landing microarchitecture are described in this chapter. Processors based on the Knights Landing microarchitecture can be identified using CPUID's DisplayFamily_DisplayModel signature, which can be found in Table 2-1 of Chapter 2, "Intel® 64 and IA-32 Processor Architectures" of *Intel® 64 and IA-32 Architectures Software Developer's Manual, Volume 4*.

This chapter begins with a high level description of the Knights Landing microarchitecture. The rest of the chapter covers several topics that have the highest impact for software performance when running on the Knights Landing microarchitecture: Intel® AVX-512 instructions, memory subsystems, microarchitectural specific techniques, compiler switches and directives, numeric sequences, MCDRAM as cache, and scalar versus vector coding.

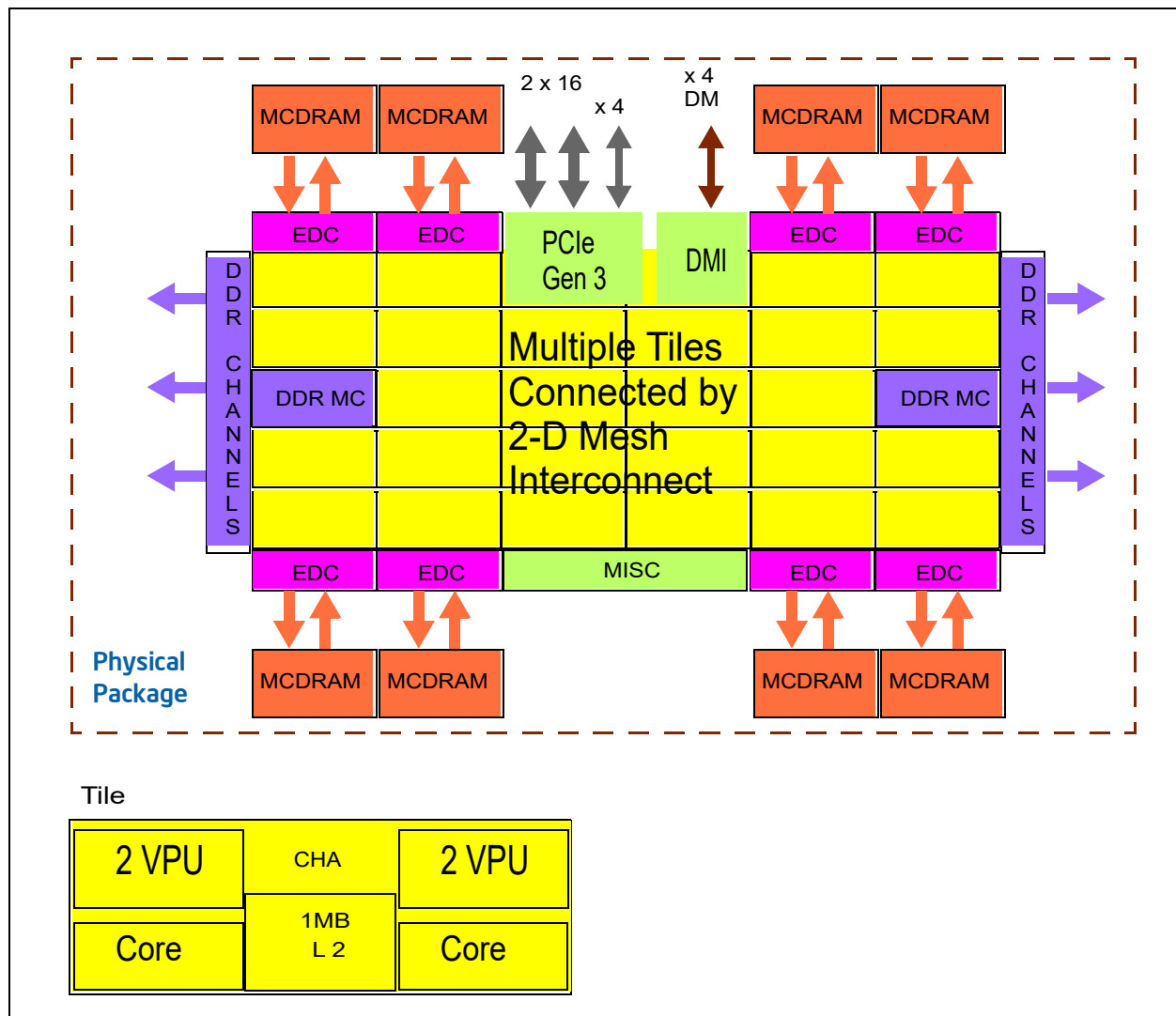

Figure 23-1. Tile-Mesh Topology of the Knights Landing Microarchitecture

23.1 KNIGHTS LANDING MICROARCHITECTURE

The Knights Landing microarchitecture is designed for processors and co-processor product families that target highly-parallel, high-performance applications. An Intel Xeon Phi processor based on the Knights Landing microarchitecture is comprised of:

- A large number of tiles.
- A two-dimensional mesh interconnect connecting the tiles.
- An advanced memory sub-system supplying data to all the tiles containing IA-compatible processor cores and cache hierarchy.

Figure 23-1 depicts a collection of “tile” units (or pairs of processor cores) connected by a two-dimensional mesh network, offering I/O capabilities via PCIe and DMI interfaces, a memory sub-system supporting high-bandwidth optimized MCDRAM, and capacity-optimized DDR memory channels.

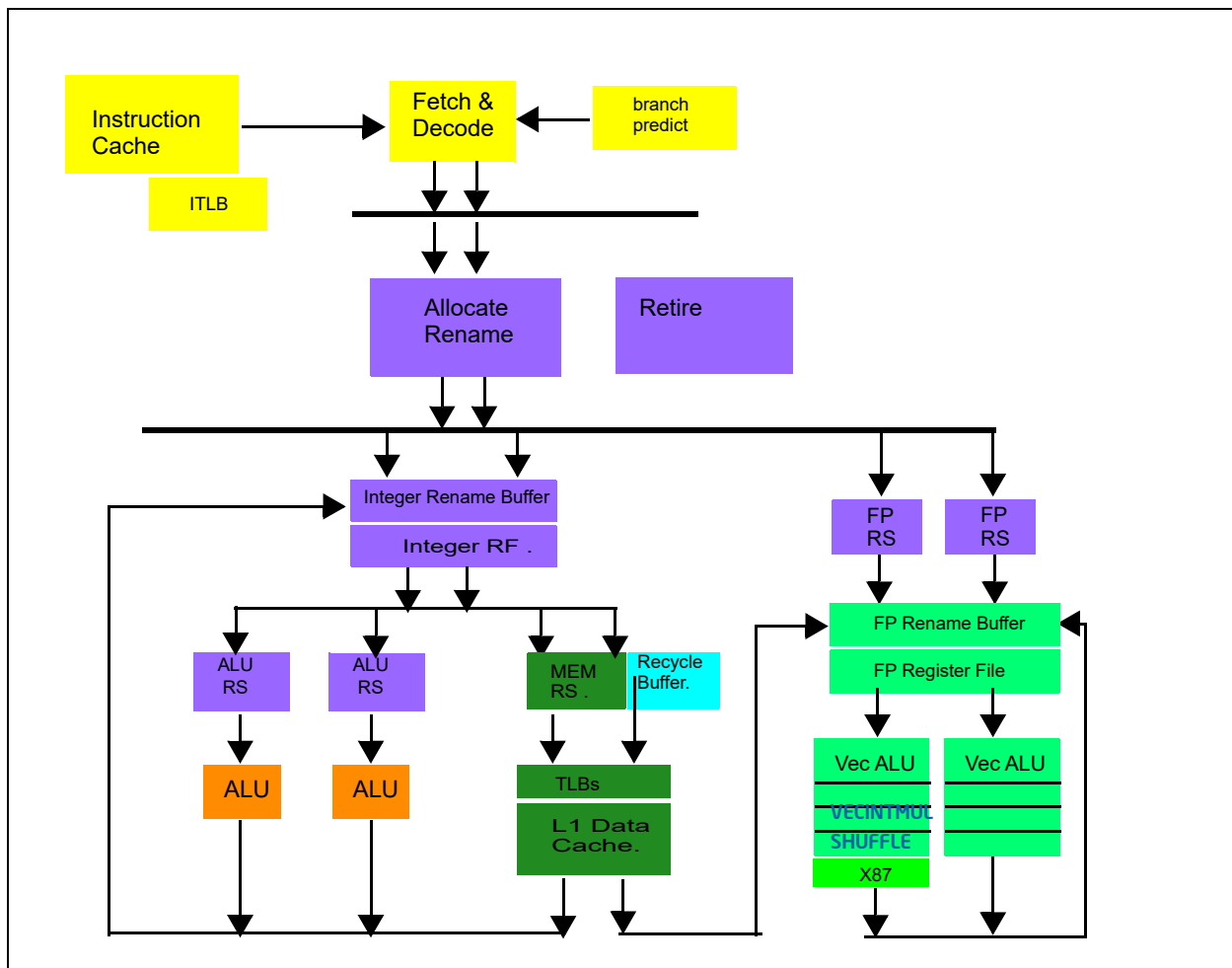

Figure 23-2. Processor Core Pipeline Functionality of the Knights Landing Microarchitecture

Figure 23-1 also illustrates each tile comprising:

- Two out-of-order IA processor cores supporting Intel® Hyper-Threading Technology with 4 logical processors per core.
- A 1 MByte L2 cache shared between the two processor cores in the tile.
- A Caching Homing Agent (CHA) connecting each tile to the 2-D mesh interconnect.
- Each processor core also provides a dedicated vector processing unit (VPU) capable of executing 512-bit, 256-bit, 128-bit and scalar SIMD instructions.

Figure 23-2 illustrates the microarchitectural pipelines of a processor core (including the VPU pipelines) inside a tile.

The processor core in the Knights Landing microarchitecture provides the following features:

- An out-of-order (OOO) execution engine with 6-wide execution (2 VPU, 2 memory, 2 integer) pipeline. Specifically, the out-of-order engine is supported by:
 - The front end can decode two instructions per-cycle into micro-ops (uops).
 - The allocate/rename stage is also two-wide.
 - The out-of-order engine has distributed reservation stations (72-entry deep) feeding the integer, memory, and VPU pipelines.
- The VPU can execute AVX-512F, AVX-512CD, AVX-512ER, AVX-512PF, AVX, and 128-bit SIMD/FP instructions.
- The VPU can perform two 512-bit FMA operations per cycle; x87 and MMX instructions throughput is limited to one per cycle.
- Each processor core supports 4 logical processors via Intel Hyper-Threading Technology.
- Two processor cores share a 1 MByte L2 cache and form a tile.

23.1.1 Front End

The front end can fetch 16 bytes of instructions per cycle. The decoders can decode up to two instructions of not more than 24 bytes in a cycle. The decoders can only provide a single uop per instruction. If an instruction decodes into multiple uops (e.g., VSCATTER*), the microcode sequencer (MS) will supply the uop flow with a performance bubble of 3-7 cycles, depending on instruction alignment in the decoder and length of the MS flow. The decoder will also have a small delay if a taken branch is encountered. If an instruction has more than 3 prefixes, there will be a multi-cycle bubble.

The front end is connected to the OOO execution engine through the Allocation, Renaming and Retirement cluster. Scheduling of uops is handled with distributed reservation stations across the integer, memory and VPU pipelines.

23.1.2 Out-of-Order Engine

The reorder buffer (ROB) is 72 uops deep. There are 16 store buffers (for both address and data). Distributed scheduling of uops include (see Figure 23-2):

- Two integer reservation stations (one per dispatch port) are 12 entries each.
- The single MEC reservation station has 12 entries, and dispatches up to 2 uops per cycle.
- The two VPU reservation stations (one per dispatch port) are 20 entries each.

The reservation stations, ROB, and store data buffers are hard partitioned per logical processor (depending on the processor core operating with 1, 2, or 4 active logical processors). Hard partitioning of resources changes as logical processors wake up and go to sleep. The store address buffers have two entries reserved per logical processor, with the remaining entries shared among the logical processors.

The integer reservation stations can dispatch 2 uops per cycle each, and are able to do so out-of-order. The memory execution reservation station dispatches 2 uops from its scheduler in-order, but uops can complete in any order. The data cache can read two 64B cache lines and write one cache line per cycle. The VPU reservation stations can dispatch 2 uops per cycle each and complete out-of-order.

The OOO engine in the Knights Landing microarchitecture is optimized to favor execution throughput over latency. Loads to integer registers (e.g., RAX) are 4 cycles, and loads to VPU registers (e.g., XMM0, YMM1, ZMM2, or MM0) are 5 cycles. Only one integer load is possible per cycle, but the other memory operations (store address, vector load, and prefetch) can dispatch two per cycle. Stores commit post-retirement, at a rate of 1 per cycle. The data cache and instruction caches are each 32 KB in size.

Most commonly-used integer math instructions (e.g. add, sub, cmp, test) have a throughput of 2 per cycle with latency of a single cycle. The integer pipeline has only one integer multiplier with a latency of 3 or 5 cycles depending on the operand size. Latency of integer division will vary depending on the operand size and input value; its throughput is expected to be not faster than one every ~20 cycles. Store to load forwarding has a cost of 2 cycles and can forward one per cycle if the store-forwarding restrictions are met. see Table 23-1.

Table 23-1. Integer Pipeline Characteristics of the Knights Landing Microarchitecture

Integer Instruction/operations	Latency (cycle)	Throughput (cycles per instruction)
Simple Integer	1	0.5
Integer Multiply	3 or 5	1
Integer Divide	Varies	> 20
Store to Load Forward	2	1
Integer Loads	4	1

Many VPU math operations can dispatch on either VPU port with a latency of either 2 cycles or 6 cycles; see Table 23-2. The following instructions can only dispatch on a single port:

- All x87 math operations.
- FP divisions and square roots.
- AVX-512ER.
- Vector permute / shuffle operations.
- Vector to integer moves.
- AVX-512CD conflict instructions.
- AESNI.
- The store data operation of a vector instruction with store semantics.

The above operations are limited to one of the two VPU dispatch pipes. Vector store data and vector to integer moves are on one dispatch pipe. The remaining single pipe instructions are on the other dispatch pipe.

Table 23-2. Vector Pipeline Characteristics of the Knights Landing Microarchitecture

Vector Instructions	Latency (cycle)	Throughput (cycles per instruction)
Simple Integer	2	0.5
Most Vector Math (including FMA)	6	0.5
Mask Instructions (operating on opmask)	2	0.5
AVX-512ER (64-bit element)	7	2
AVX-512ER (32-bit element)	8	3
Vector Loads	5	0.5
Store to Load Forward	2	0.5
Gather (8 elements)	15	5
Gather (16 elements)	19	10
Register Move (GPR -> XMM/YMM/ZMM)	2	1
Register Move (XMM/YMM/ZMM -> GPR)	4	1
DIVSS/SQRTSS ¹	25	~20
DIVSD/SQRTSD ¹	40	~33
DIVP*/SQRTP* ¹	38	~10
Shuffle/Permute (1 source operand) ¹	2	1
Shuffle/Permute (2 source operands) ¹	3	2
Convert (from/to same width) ¹	2	1
Convert (from/to different width) ¹	6	5
Common x87/MMX Instructions ¹	6	1

NOTES:

1. The physical units executing these instructions may experience additional scheduling delay due to the physical layout of the units in the VPU.

Additionally, some instructions in the Knights Landing microarchitecture will be decoded as one uop by the front end but need to expand to two operations for execution. These complex uops will have an allocation throughput of one per cycle. Examples of these instructions are:

- POP: integer load data + ESP update
- PUSH: integer store data + ESP update
- INC: add to register + update partial flags
- Gather: two VPU uops
- RET: JMP + ESP update
- CALL, DEC, LEA with 3 sources

Table 23-3 lists characteristics of the caching resources in the Knights Landing microarchitecture.

Table 23-3. Characteristics of Caching Resources

	Sets	Ways	Latency	Capacity/Comments
uTLB	8	8	1	64 4KB pages (fractured) ¹
DTLB (4KB page)	32	8	4	256 4KB pages
DTLB (2M/4M page)	16	8	4	128 2MB/4MB pages
DTLB (1GB page)	1	16	4	16 1GB pages
ITLB	1	48	4	48 4KB pages (fractured)
PDE	8	4	1	Page descriptors
L1 Data Cache	64	8	4 or 5	32 KB
Instruction Cache	64	8	4	32 KB
Shared L2 Cache	1024	16	13+L1 latency	1 MB

NOTES:

1. The uTLB and ITLB can only hold translations for 4 KB memory regions. If the relevant page is larger than 4 KB (such as 2MB or 1 GB), then the buffer holds the translation for the portion of the page that is being accessed. This smaller translation is referred to as a fractured page.

23.1.3 UnTile

In the Knights Landing microarchitecture, many tiles are connected by a mesh interconnect into a physical package; see Figure 23-1. The mesh and associated on-package components are referred to as “untile”. At each mesh stop, there is a connection to the tile and a tag directory that identifies which L2 cache (if any) holds a particular cache line. There is no shared L3 cache within a physical package. Memory accesses that miss in the tile must go over the mesh to the tag directory to identify any cached copies in another tile. Cache coherence uses the MESIF protocol. If the cache line is not cached in another tile, then a request goes to memory.

MCDRAM is an on-package, high bandwidth memory subsystem that provides peak bandwidth for read traffic, but lower bandwidth for write traffic (compared to reads). The aggregate bandwidth provided by MCDRAM is higher than the off-package memory subsystem (i.e., DDR memory). DDR memory bandwidth can potentially be saturated by writes or reads alone. The achievable memory bandwidth for MCDRAM is approximately 4x - 6x of what DDR can do, depending on the mix of read and write traffic.

MCDRAM capacity supported by the Knights Landing microarchitecture is either 8 or 16 GB, depending on product-specific features. The peak MCDRAM bandwidth will vary according to the size of the installed MCDRAM. MCDRAM has higher bandwidth but lower capacity than DDR. The Maximum DDR capacity is 384 GB for the Knights Landing microarchitecture.

The physical memory in a platform comprises both MCDRAM and DDR memory; they can be partitioned in a number of different modes of operation. The commonly-used modes are summarized below.

- Cache mode: MCDRAM as a direct mapped cache and DDR is used as system memory addressable by software.
- Flat mode: MCDRAM and DDR map to disjoint addressable, system memory.
- Hybrid mode: MCDRAM is partitioned; parts of MCDRAM act as direct mapped cache, the rest of MCDRAM is directly addressable. DDR map to addressable system memory.

The configuration between tiles, tag directories and the mesh support the following modes of clustering operation for cache coherent traffic:

- All-to-All: the requesting core, tag directory and memory controller for a cache line can be anywhere in the mesh.
- Quadrant: the tag directory and memory that it monitors are in the same quadrant of the mesh, but the requesting core can be anywhere in the mesh.
- Sub-NUMA Clustering (SNC): In SNC mode, BIOS expose each quadrant as a NUMA node. This requires software to recognize the NUMA domains and co-locate the requesting core, tag directory, and memory controller in the same quadrant of the mesh to realize the benefit of optimal cache miss latency.

If critical portions of an application working set fit in the capacity of MCDRAM, performance could benefit greatly by allocating it into the MCDRAM and using flat or hybrid mode. Cache mode is generally best for code that has not yet been optimized for the Knights Landing microarchitecture, and has a working set that MCDRAM can cache.

In general, cache miss latency in All-to-All mode will be worse than it is in Quadrant mode; SNC mode can achieve the best latency. Quadrant mode is the default mesh configuration. SNC clustering requires some support from software to recognize the different NUMA nodes. If DDR is not populated evenly (e.g., missing DIMMs), the mesh will need to use the All-to-All clustering mode.

When multiple tiles read the same cache line, each tile might have a copy of the cache line. If both cores in the same tile read a cache line, there will only be a single copy in the L2 cache of that tile.

If MCDRAM is configured as a cache, it can hold data or instructions accessed by the cores in a single place. If multiple tiles request the same line, only one MCDRAM cacheline will be used.

L1 data cache has higher bandwidth and lower latency than L2 cache. Cache line access from L2 has higher bandwidth and lower latency than access from memory.

MCDRAM and DDR memory have different latency and throughput profiles. This becomes important when choosing between cache vs. flat or other memory modes. In most memory configurations, the DDR capacity will be substantially larger than MCDRAM capacity. Likewise, MCDRAM capacity should be much larger than the combined L2 cache.

Working sets that fit in MCDRAM capacity, but not in the L2 cache, should be in MCDRAM. Large or rarely accessed structures should migrate to DDR. In Knights Landing microarchitecture, hardware will try to do this dynamically if MCDRAM is put in cache or hybrid memory modes. If memory is in the flat memory mode, data structures are bound to one memory or the other (MCDRAM or DDR) at allocation time. The programmer should strive to maximize the number of memory access that go to MCDRAM. One possible algorithm would allocate data structures into MCDRAM if they are frequently accessed, and have working sets that do not fit into the tile caches.

In cache memory mode, the MCDRAM access is done first. If the cacheline is not in MCDRAM, the DDR access begins. Because of this, the perceived memory access latency of DDR in cache memory mode is higher than in flat memory mode.

23.2 INTEL® AVX-512 CODING RECOMMENDATIONS FOR KNIGHTS LANDING MICROARCHITECTURE

The Intel AVX-512 family comprises a collection of instruction set extensions. For an overview and detailed features (EVEX prefix encoding, opmask support, etc.) of the Intel AVX-512 family of instructions, see the Intel® 64 and IA-32 Architectures Software Developer's Manual, Volume 1. Intel Xeon Phi processors (7200, 5200, 3100 series) based on the Knights Landing microarchitecture support AVX-512 Foundation (AVX-512F), AVX-512 Exponential and Reciprocal (AVX-512ER), AVX-512 Conflict (AVX-512CD), and AVX-512 Prefetch extensions. Intel AVX and Intel AVX2 instructions are also supported on processors based on the Knights Landing microarchitecture. Prior generation Intel Xeon Phi processors (7100, 5100, 3100 series) do not support Intel AVX-512, Intel AVX2, nor Intel AVX instructions.

23.2.1 Using Gather and Scatter Instructions

Gather instructions in AVX-512F are enhanced over those in Intel AVX2, performing 512-bit operations (either 16 elements of 32-bit data or 8 elements of 64-bit data) and using an opmask register as write-mask for conditional updates of fetched elements to the destination ZMM register.

Scatter instructions in AVX-512F selectively store elements in a ZMM register to memory locations expressed via an index vector. Conditional store to the destination location is selected using an opmask register. Scatter instructions are not supported in Intel AVX or Intel AVX2.

Consider the following C code fragment:

```
for (uint32 i = 0; i < 16; i ++) {
    b[i] = a[indirect[i]];
    // vector compute sequence
}
```

Example 23-1. Gather Comparison Between AVX-512F and AVX2

AVX-512F	AVX2
vmovdqu zmm0, [rsp+0x1000]; load indirect[] kxnor k1,k0, k0; prepare mask vpgatherdd zmm2{k1}, [rax+zmm0*4] ; compute sequence using vector register	vmovdqu ymm0, [rsp+0x1000]; load half of index vector vmovdqu ymm3, [rsp+0x1020]; 2nd half of indirect[] vpcmpeqdd ymm4, ymm4, ymm4; prepare mask vmovdqa ymm1, ymm4 vpgatherdd ymm2, [rax+ymm0*4], ymm1 vpgatherdd ymm5, [rax+ymm3*4], ymm4 ; compute sequence using vector register

When using VGATHER and VSCATTER, you often need to set a mask to all ones. An efficient instruction to do this is KXNOR of a mask register with itself. Since VSCATTER and VGATHER clear their mask as the last thing they do, a loop carried dependence from the VGATHER to KXNOR can be generated. Because of this, it is wise to avoid using the same mask for source and destination in KXNOR. Since it is rare for the k0 mask to be used as a destination, it is likely that "KXNORW k1, k0, k0" will be faster than "KXNOR k1, k1, k1".

Gather and Scatter instructions in AVX-512F are different from those in prior generation Intel Xeon Phi processors (abbreviated by "Previous Generation" in Example 23-2).

Example 23-2. Gather Comparison Between AVX-512F and Previous Generation Equivalent

AVX-512F	Previous Generation Equivalent Sequence
vmovdqu zmm0, [rsp+0x1000]; load indirect[] kxnor k1,k0, k0; prepare mask vpgatherdd zmm2{k1}, [rax+zmm0*4] ; compute sequence using vector register	vmovdqu zmm0, [rsp+0x1000]; load indirect[] kxnor k1,k1; prepare mask g_loop: ; verify gathered elements are complete vpgatherdd zmm2{k1}, [rax+zmm0*4] jknzd k1, g_loop; gather latency exposure ; compute sequence using vector register

23.2.2 Using Enhanced Reciprocal Instructions

The AVX-512ER instructions provide high precision approximations of exponential, reciprocal, and reciprocal square root functions. The approximate math instructions in AVX-512ER provide 28 bits of accuracy, compared to 11 bits in RCPSS or 14 bits with VRCP14SS. AVX-512ER can reduce execution time for iterative algorithms like Newton-Raphson. Example 23-3 below contains sample code using the Newton-Raphson algorithm to compute a single 32b float division with VRCP28SS. Both values are read off the stack. Note the use of rounding mode overrides on some of the math operations.

Example 23-3. Using VRCP28SS for 32-bit Floating-Point Division

```

vgetmantss    xmm18, xmm18, [rsp+0x10], 0
vgetmantss    xmm20, xmm20, [rsp+0x8], 0
vrCP28ss      xmm19, xmm18, xmm18
vgetxpss      xmm16, xmm16, [rsp+0x8]
vgetxpss      xmm17, xmm17, [rsp+0x10]
vsubss        xmm22, xmm16, xmm17
vmulss        xmm21{rne-sae}, xmm19, xmm20
vfmadd231ss   xmm20{rne-sae}, xmm21, xmm18
vfmadd231ss   xmm21, xmm19, xmm20
vscalefss     xmm0, xmm21, xmm22

```

23.2.3 Using AVX-512CD Instructions

Refer to Section 18.16, “Conflict Detection” for details on using the Intel AVX-512 Conflict Detection instructions.

23.2.4 Using Intel® Hyper-Threading Technology

The Knights Landing microarchitecture supports 4 logical processors with each processor core. There are choices that highly-threaded software may need to consider with respect to:

- Maximizing per-thread performance by providing maximum per-core resources to one logical processor per core.
- Maximizing per-core throughput by allowing multiple logical processors to execute on a processor core.

As thread count per core grows to 2 or 4, some applications will have higher per core performance, but lower per thread performance. If an application can perfectly scale its performance to an arbitrary number of threads, 4 threads per core is likely to have the highest instruction throughput. Practical limitations on memory capacity or parallelism may limit the number of threads per core.

In Knights Landing microarchitecture, some per core resources (like the ROB or scheduler) are partitioned to one for each of 4 logical processors. Because of this, a 3 thread configuration will have fewer aggregate resources available than 1, 2, or 4 threads per core. Placing 3 threads on a processor core is unlikely to perform better than 2 or 4 threads per core.

23.2.5 Front End Considerations

To ensure front end restrictions are not typically a performance limiter, software should consider the following:

- MSROM instructions should be avoided if possible. A good example is the memory form of CALL near indirect. It will often be better to perform a load into a register and then perform the register version of CALL. Additional examples are shown in Table 23-4.
- The total length of the instruction bytes that can be decoded each cycle is at most 16 bytes per cycle with instructions not more than 8 bytes in length. For instruction length exceeding 8 bytes, only one instruction per cycle is decoded on decoder 0. Vector instructions which address memory using 32-bit displacement can cause the decoder to limit performance.
- Instructions with multiple prefixes can restrict decode throughput. The restriction is on the length of bytes combining prefixes and escape bytes. There is a 3 cycle penalty when the escape/prefix count

exceeds 3 with the Knights Landing microarchitecture. Only decoder 0 can decode an instruction exceeding the limit of a prefix/escape byte restriction.

- Maximum number of branches that can be decoded each cycle is 1.

23.2.5.1 Instruction Decoder

Some IA instructions require a lookup in the microcode sequencer ROM (MSROM) to decode into a multiple uop flow. Choosing an alternative sequence of instructions which does not require MSROM will improve performance.

Table 23-4 provides alternate non-MSROM instruction sequences that can replace an instruction that decodes from MSROM.

Table 23-4. Alternatives to MSROM Instructions

Instruction from MSROM	Recommendation for Knights Landing
CALL m16/m32/m64	Load + CALL reg
PUSH m16/m32/m64	Store + RSP update
(I)MUL r/m16 (Result DX:AX)	Use (I)MUL r16, r/m16 if extended precision not required, or (I)MUL r32, r/m32
(I)MUL r/m32 (Result EDX:EAX)	Use (I)MUL r32, r/m32 if extended precision not required, or (I)MUL r64, r/m64
(I)MUL r/m64 (Result RDX:RAX)	Use (I)MUL r64, r/m64 if extended precision not required

23.2.5.2 Branching Indirectly Across a 4GB Boundary

Another important performance consideration from a front end standpoint is branch prediction for indirect branches (indirect branch or call, or ret). For 64-bit applications, indirect branch prediction fails when the target of a branch is in a different 4GB chunk of the address space from the source. (I.e. the top 32 bits of the virtual addresses of the source and target are different). This is more likely to happen when the application is split into shared libraries. Developers can build statically to improve the locality in their code, particularly for latency-sensitive library calls that are accessed frequently. Another option is to use glibc 2.23 or later, and set the LD_PREFER_MAP_32BIT_EXEC environment variable which requests that the dynamic linker place all shared libraries at the bottom of the address space.

23.2.6 Integer Execution Considerations

23.2.6.1 Flags usage

Many instructions have an implicit data result that is captured in a flags register. These results can be consumed by a variety of instructions such as conditional moves (cmovs), branches, and even a variety of logic/arithmetic operations (such as rcl). The most common instructions used in computing branch conditions are compare instructions (CMP). Branches dependent on the CMP instruction can execute in the next cycle. The same is true for branch instructions dependent on ADD or SUB instructions.

INC and DEC instructions require an additional uop to merge the flags as they are partial flag writers. As a result, an INC or a DEC instruction should be replaced by "ADD reg, 1" or "SUB reg, 1" to avoid a partial flag penalty.

Instructions that operate on 8-bit or 16-bit registers are not optimized in hardware in the Knights Landing microarchitecture. In general, it is faster to use integer instructions operating on 32-bit or 64-bit general purpose registers than 8-bit or 16-bit registers.

23.2.6.2 Integer Division

Integer division can be a common operation in some mathematical expressions. However, using hardware integer divide instructions is often less than optimal in performance. If the divisor is known to be relatively small (16 bits or less), there are fast SW sequences to emulate the division. If the divisor is known to be a power of 2, use SHR (division) and/or AND (remainder) instead of DIV. Division by a constant can be replaced by MUL with a constant. If the input values are highly constrained, a pre-computed lookup table is likely to provide better performance. Some examples of the techniques can be found in Section 13.2.4, “Replace 128-bit Integer Division with 128-bit Multiplication,” and Section 14.5, “Numerical Data Conversion to ASCII Format.”

Division instructions should be aggressively minimized by the compiler, either using the techniques mentioned earlier, or by hoisting redundant divisions out of inner loops.

23.2.7 Optimizing FP and Vector Execution

23.2.7.1 Instruction Selection Considerations

In general, using 512-bit instructions are more favorable to achieve higher throughput than 256-bit instructions. The same applies relative to 256-bit vs. 128-bit vector instructions. 128-bit SSE instructions are likely to achieve higher throughput than using X87 instruction equivalents. Often, X87 instruction functionality (transcendental) not present in vector instruction extensions natively can be replaced by library implementations using vector instructions.

In the Knights Landing microarchitecture, COMIS* and UCOMIS* instructions (legacy, VEX, or EVEX encoding) that update EFLAGS are slow. These should be replaced by a more optimal sequence of the AVX-512F version of VCMPS* and KORTTEST.

Example 23-4. Replace VCOMIS* with VCMPS/KORTTEST

```
vcmpps k1, xmm1, xmm2, imm8 ; specify imm8 according to desired primitive
kortest k1, k1
```

Some instructions, like VCOMPRESS*, are single uop when writing a register, but an MS flow when writing memory. Where possible, it is much better to do a VCOMPRESS to register and then store it. Similar optimizations apply to all vector instructions that do some sort of operation followed by a store (e.g., PEXTRACT).

In the Knights Landing microarchitecture, mixing SSE instructions and Intel AVX instructions require a different set of considerations to avoid loss of performance due to intermixing of SSE and Intel AVX instructions. Replace SSE code with AVX-128 equivalents, whenever possible.

Situations that can result in a performance penalty are:

- If an Intel AVX instruction encoded with a vector length of more than 128 bits is allocated before the retirement of previous in-flight SSE instructions.
- VZEROUPPER instruction throughput is slow, and is not recommended to preface a transition to AVX code after SSE code execution. The throughput of VZEROALL is also slow. Using either the VZEROUPPER or the VZEROALL instruction is likely to result in performance loss.

Conditional packed load/store instructions, like MASKMOVDQU and VMASKMOV, use a vector register for element selection. AVX-512F instructions provide alternatives using an opmask register for element selection and are preferred over using a vector register for element selection.

Some vector math instructions require multiple uops to implement in the VPU. This increases the latency of the individual instruction beyond the standard math latencies of 2 and 6. In general, instructions that alter output/input element width (e.g., VCVTSD2SI) fall into this category. Many Intel AVX2 instructions

that operate on byte and word quantities have reduced performance compared to the equivalents that operate on 32b or 64b quantities.

Some execution units in the VPU may incur scheduling delay if a sequence of dependent uop flow needs to use these execution units, these outlier units are indicated by the footnote of Table 16 2. When this happens, it will have an additional cost of a 2-cycle bubble. Code that frequently transition between the outlier units with other units in the VPU can experience a performance issue due to these bubbles.

Most of the Intel AVX-512 instructions support using an opmask register to make conditional updates to the destination. In general, using an opmask with all 1's will be the fastest relative to using an opmask with other non-zero values. Using a non-zero opmask value, the instruction will be similar in speed relative to an opmask with all 1s, if zeroing-the-non-updated element is selected. Using a non-zero opmask value with merging (preserving) non-updated elements of the destination will likely be slower.

Horizontal add/subtraction instructions in Intel AVX2 do not have promoted equivalents in Intel AVX-512. Horizontal reduction is best implemented using software sequences; see Example 23-5.

In situations where an algorithm needs to perform reduction, reduction can often be implemented without horizontal addition.

Example 23-6 shows code fragment for the inner loop of a DGEMM matrix multiplication routine, which computes the dense matrix operation of $C = A * B$.

In Example 23-6, there are 16 partial sums. The sequence of FMA instructions make use of the two VPU capability of 2 FMAs per cycle throughput, 6 cycles latency. The FMA code snippet in Example 23-6 is presented using uncompressed addressing form for the memory operand. It is important for code generators to ensure optimal code generation will make use of compressed disp8 addressing form, so that the length of each FMA instruction will be less than 8 bytes. At the end of the inner loop, the partial sums will need to be aggregated and store the result matrix C to memory.

Example 23-5. Using Software Sequence for Horizontal Reduction

<pre>vextractf64x4 ymm1, zmm6, 1; reduction of 16 elements vaddps ymm1, ymm6, ymm1 vpermpd ymm4, ymm1, 0xff vpermpd ymm5, ymm1, 0xaa vpermpd ymm3, ymm1, 0x44 vaddps xmm1, xmm1, xmm4 vaddps xmm3, xmm5, xmm3 vaddps xmm3, xmm1, xmm3 vpsrlq xmm1, xmm3, 32 vaddss xmm3, xmm1, xmm3</pre>	<pre>vextractf64x4 ymm1, zmm6, 1; reduction of 8 elements vaddps ymm1, ymm6, ymm1 valignq ymm4, ymm1, 0x3 valignq ymm5, ymm1, 0x2 valignq ymm3, ymm1, 0x1 vaddsd ymm1, ymm1, ymm4 vaddsd ymm3, ymm5, ymm3 vaddsd ymm3, ymm1, ymm3</pre>
--	--

Example 23-6. Optimized Inner Loop of DGEMM for Knights Landing Microarchitecture

```

;; matrix - matrix dense multiplication
prefetcht0 [rdi+0x400] ;; get A matrix element into L1$
vmovapd zmm30, [rdi]
prefetcht0 [rsi+0x400] ;; get B matrix element into L1$
vfmadd231pd zmm1, zmm30, [rsi+r12]{b} ;; broadcast B elements
vfmadd231pd zmm2, zmm30, [rsi+r12+0x08]{b} ;; displacement shown in un-compressed form
vfmadd231pd zmm3, zmm30, [rsi+r12+0x10]{b}
vfmadd231pd zmm4, zmm30, [rsi+r12+0x18]{b}
vfmadd231pd zmm5, zmm30, [rsi+r12+0x20]{b}
vfmadd231pd zmm6, zmm30, [rsi+r12+0x28]{b}
vfmadd231pd zmm7, zmm30, [rsi+r12+0x30]{b}
vfmadd231pd zmm8, zmm30, [rsi+r12+0x38]{b}

prefetcht0 [rsi+0x440] ;; pull line into the L1$
vfmadd231pd zmm9, zmm30, [rsi+r12+0x40]{b}
vfmadd231pd zmm10, zmm30, [rsi+r12+0x48]{b}
vfmadd231pd zmm11, zmm30, [rsi+r12+0x50]{b}
vfmadd231pd zmm12, zmm30, [rsi+r12+0x58]{b}
vfmadd231pd zmm13, zmm30, [rsi+r12+0x60]{b}
vfmadd231pd zmm14, zmm30, [rsi+r12+0x68]{b}
vfmadd231pd zmm15, zmm30, [rsi+r12+0x70]{b}
vfmadd231pd zmm16, zmm30, [rsi+r12+0x78]{b}

```

23.2.7.2 Porting Intrinsics from Previous Generation

Most intrinsics map to individual instructions of the native hardware. Some 512-bit intrinsics may provide syntax that hides the difference between AVX-512F and the 512-bit incompatible previous generation instruction set.

However, intrinsic code that is optimized to run on previous generations will likely not run optimized on the Knights Landing microarchitecture, due to differences in the underlying microarchitecture (e.g., unaligned memory access, cost differences of permutes, limitations of previous generations).

It is likely that coding an algorithm in a high level language (C/Fortran) to compile with Intel Compilers supporting AVX-512F will generate more optimal code than using previous generation intrinsics.

23.2.7.3 Vectorization Trade-Off Estimation

Profitability of vectorization of loops written in a high-level language to use AVX-512 is an important part of optimization for compilers as well as for hand coding assembly. Estimating this for the simplest type of loop construct can be based on trip count alone. For example, a trip count of 4 or less may be difficult to realize performance gain over scalar code. With Intel AVX-512, a trip count of 16 may be the minimum to consider vectorization.

Estimation of vectorization trade-off for more elaborate loop construct requires more sophistication. The rest of this section provides an analytic approach of examining the composition within the loop body and makes use of a table of cost estimates of basic operations, Table 23-5, to derive the trade-off comparison between vectorization versus scalar code.

Table 23-5. Cycle Cost Building Blocks for Vectorization Estimate for Knights Landing Microarchitecture

Operation	Cost (cycles)	Example Code Construct
Simple scalar math	1	$A*B+C$, or $A+B$, or $A*B$
Load (split cacheline)	1 (2)	$A[i]$ /* load reference to an array element */
Store (split cacheline)	1(2)	$A[i] = 2;$
Gather (Scatter) 8 elements	15 (20)	$A[key[i]]$
Gather (Scatter) 16 elements	20 (25)	$A[key[i]] ;$
Horizontal reduction	30	$sum += A[i]$
Division or Square root	15	A/B

To illustrate the cost build-up approach, consider the simple loop:

```
for (i=0; i<N; i++) { sum += a[i]*K + b[i]; }
```

Within the loop body, the basic operations consist of:

- Two loads ($a[i]$, $b[i]$) per iteration.
- An FMA per iteration.
- For scalar version: an accumulate per loop iteration; for vectorization: a horizontal reduction at the end of the loop.

The total cost of N trips for scalar code is $4N$. By comparison, the total cost for vectorized code using AVX-512 on a 64-bit data element would be $3 * \text{Ceiling}(N/8) + 30$, assuming both the main loop and remainder loop (if N is not multiples of 8) are vectorized. Therefore, profitable vectorization will need a trip count of at least 9.

Consider another example involving fetching data from irregular access patterns which might take advantage of GATHER instructions:

```
for (i=0; i<N; i++) { c[i] = a[indir[i]] * K + b[i]; }
```

Within the loop body, the basic operations consist of:

- Two loads ($indir[i]$, $b[i]$) per iteration.
- An FMA per iteration.
- A store per iteration.
- For scalar version: a 3rd load per loop iteration; for vectorization: one GATHER per 8 iteration.

The total cost of N trips for scalar code is $5N$. By comparison, the total cost for vectorized code would be $19 * \text{Ceiling}(N/8)$. Scalar would be faster if $N < 4$.

Consider an example involving fetching data from twice irregular access patterns than the previous example:

```
for (i=0; i<N; i++) {c[i] = a[ind[i]]*K + b[ind[i]]; }
```

- One load (ind[i]) per iteration.
- An FMA per iteration.
- A store per iteration.
- For scalar version: two more loads per loop iteration; for vectorization: two GATHERs per 8 iteration.

The total cost of N trips for scalar code is still 5N. By comparison, the total cost for vectorized code would be $(15*2 + 3)* \text{Ceiling}(N/8) = 33* \text{Ceiling}(N/8)$. Even a relatively small profitability of vectorization will require a significantly larger trip count.

Consider the next example involving fetching data from one irregular access pattern and horizontal reduction:

```
for (i=0; i<N; i++) {sum += a[ind[i]]*K + b[i]; }
```

Scalar cost is still 5N. Cost of vectorization is now $19*\text{Ceiling}(N/8) + 30$. Scalar code would be faster for $N \leq 13$.

Consider an example of scatter with division:

```
for (i=0; i<N; i++) {c[ind[i]] = a[i] / b[i]; }
```

The scalar cost is $(15+4)*N$. Cost of vectorization would be $(15+20+3)*\text{Ceiling}(N/8)$. Vectorization would be profitable for $N > 2$.

In the case of gather followed by scatter:

```
for (i=0; i<N; i++) {b[ind[i]] = a[ind[i]]; }
```

The cost of scalar code is $3*N$, and vector code will cost $(15+20+1)*\text{Ceiling}(N/8)$. Vectorization will not be profitable.

For a loop body that is more complex, consider the code below from a workload known as miniMD:

```
for (int k = 0; k < numneigh; k++) {
    int j = neighs[k];
    double rsq = (xtmp - x[3*j])^2 +
                (ytmp - x[3*j+1])^2 +
                (ztmp - x[3*j+2])^2;
    if (rsq < cutforcesq) {
        double sr2 = 1.0/rsq;
        double sr6 = sr2*sr2*sr2;
        double force = sr6*(sr6-0.5)*sr2;
        res1 += delx*force;
        res2 += dely*force;
        res3 += delz*force;
    }
}
```

Before considering the IF clause, there is one load, 3 gathers (strided loads of $x[]$), 3 subtractions and 3 multiplies. Inside the IF clause, there is one division, 8 math operations, and 3 horizontal reductions. The scalar cost is $10 * \text{numneigh} + 23 * \text{numneigh} * \text{percent_rsq_less_than_cutforcesq}$. The vector cost is $(52+23) * \text{Ceiling}(\text{numneigh} / 8) + 3 * 30$. Scalar code makes sense if $\text{numneigh} < 6$ or if the compiler is highly confident that the if clause is almost never taken.

For many compilers, a vectorized loop is generated, and a remainder loop is used to take care of the rest of the operations. In other words, the vectorized loop is executed $\text{floor}(N/8)$ times, and the remainder loop is executed $N \bmod 8$ times. In that case, modify the equations above to use floor instead of ceiling to determine whether the primary loop should be vectorized. For the remainder loop, the maximum value of the loop trip count is known. If N is unknown, it is simplest to set N to half the maximum value (4 for a ZMM vector of doubles).

More sophisticated analysis is possible. For example, the building block simple math operation of 1-cycle cost in Table 23-5 covers common instruction sequences that are not blocked by a dependency chain or long latency operations. Expanding entries of the cost table can cover more complex situations.

23.2.8 Memory Optimization

23.2.8.1 Data Alignment

Data access to address spanning a cache line boundary will experience a small performance hit. Access patterns that stream through memory can avoid cache line splits to make sure each 64-byte access is aligned to a cache line boundary. When loading 32-bytes of memory to YMM, do not access 64-bytes of memory with an opmask value to mask off the high 32 bytes.

Memory references crossing a 4-Kbytes boundary will incur significant cost in performance. Access patterns that stream throughput memory using 512-bit instructions have a higher rate of crossing a 4-Kbytes boundary. So alignment to 64 byte will also avoid the penalty of a page split.

If possible to predict the distance in code space of the next crossing of page boundary, it can be helpful to insert a PREFETCHT1 (to L2) a few iterations ahead of the current read stream. This can also start the page translation early and permit the L2 hardware prefetcher to start fetching on the next page.

Some access patterns which might intend to use gather and scatter will always have pairs of consecutive addresses. One common example is complex numbers, where the real and imaginary parts are laid out contiguously. It is also common when w, x, y, and z information is contiguous. If the values are 32b, it is faster to gather and scatter the 32-bit elements as half as many 64-bit elements. If the numbers are 64 bits, then it is usually faster to load and insert a 128-bit element instead of gathering 64-bit elements.

23.2.8.2 Hardware Prefetcher

There are two types of HW prefetchers in a tile. The Instruction Pointer Prefetcher (IPP) resides in a processor core and analyzes all the accesses in the data cache and the instructions that generated the access. The prefetcher will then attempt to insert HW prefetches to the L1 cache if a strided access pattern is detected on a cacheable page. The IPP will not cross a 4k page boundary. The IPP uses the instruction address and logical processor to index into a table. For this reason, the compiler may insert NOPs into large loops (>256 B) to make instructions that access memory go into different table entries.

The L2 HW prefetcher tries to identify streaming access patterns, and can track up to 48 access patterns. A streaming access pattern touches consecutive cache lines in increasing or decreasing order - the stride detected in the L2 is always +/-1 cacheline. The 48 detectors are allocated independently of the logical processor that originated the request. Each detector looks at the accesses done within a 4 KB region. If a stream is detected, HW prefetches for later elements of the stream will be sent to the L2 cache, and if they miss, to memory. The HW prefetcher will not stream across a 4 KB boundary. If multiple access patterns are done within the same 4 KB region, the detector can get confused, and fail to detect the stream.

23.2.8.3 Software Prefetch

Knights Landing microarchitecture supports out-of-order execution. In general, it can hide cache miss latency better than previous generation in-order microarchitecture. Hence, programmers should not use the same aggressive approach to insert software prefetches.

With the two hardware prefetchers described in Section 23.2.8.2, most streaming and short stride access patterns should be detected by the hardware prefetchers. If the access pattern is streaming, a programmer might benefit from adding software prefetches beyond the current 4-KBytes page. If the access pattern is known, but non-streaming, software prefetches can be beneficial in some situations. This is especially true if the access pattern is a relatively large stride (>256 bytes), since the IPP will not fetch across a 4 KB boundary. The software prefetch will do the PMH walk to fill the TLB, and to start the memory reference early.

Generally, software prefetching into the L2 will show more benefit than L1 prefetches. A software prefetch into L1 will consume critical hardware resources (fill buffer) until the cacheline fill completes. A software prefetch into L2 does not hold those resources, and it is less likely to have a negative performance impact. If you do use L1 software prefetches, it is best if the software prefetch is serviced by hits in the L2 cache, so the length of time that the hardware resources are held is minimized.

Software prefetch instructions that are dropped will have a negative performance impact due to consuming retirement slots from an invalid address. The performance penalty of prefetching an invalid address or requiring OS privilege from user code can be very large. The performance monitoring event NUKE.ALL provides an indication of when this might be affecting your code.

23.2.8.4 Memory Execution Cluster

The MEC has limited capability in executing uops out-of-order. Specifically, memory uops are dispatched from the scheduler in-order, but can complete in any order. By re-arranging the order of memory instructions, performance may be improved if they make good use of the MEC's capability.

Example 23-7 illustrates the effect of ordering the sequence of memory instructions of two read streams accessing two arrays, a[] and b[]. The left side of Example 23-7 is the optimal sequence with the 2nd

vector load from `b[]` dispatched on cycle `N+5`, assuming an L1 cache hit. The right side of Example 23-7 is a naive ordering of the memory instructions, resulting in the 2nd vector load dispatched on cycle `N+8`.

The right side sequence uses one more register than the left side. If the pointer loads would miss L1, the benefit of left side will be greater than what is shown in the comment.

Example 23-7. Ordering of Memory Instruction for MEC

<code>movq</code>	<code>r15, [rsp+0x40]; cycle N (load &a[0])</code>	<code>movq</code>	<code>r15, [rsp+0x40]; cycle N (load &a[0])</code>
<code>movq</code>	<code>r14, [rsp+0x48]; cycle N+1 (load &b[0])</code>	<code>vmovups</code>	<code>zmm1, [r15+rax*8]; executes in cycle N+4</code>
<code>vmovups</code>	<code>zmm1, [r15+rax*8]; executes in cycle N+4</code>	<code>movq</code>	<code>r15, [rsp+0x48]; cycle N+4 (load &b[0])</code>
<code>vmovups</code>	<code>zmm2, [r14+rax*8]; cycle N+5</code>	<code>vmovups</code>	<code>zmm2, [r15+rax*8]; cycle N+8</code>

If there are many loads in the machine, it might be possible to hoist up the pointer loads, so that there are several memory references between the pointer load and de-reference, without requiring more integer registers to be reserved.

23.2.8.5 Store Forwarding

Store forwarding restriction for integer execution and the MEC in the Knights Landing microarchitecture is similar to those of the Silvermont microarchitecture. The following paragraphs describes the forwarding restrictions with the VPU.

Vector, X87, and MMX loads and stores can forward (ZMM0, YMM1, XMM2, MM3, and ST4) if the stores and loads have the same memory address and the load is not larger than the store. VPU stores cannot forward to integer loads, and integer stores cannot forward to VPU loads. In either case, the load must wait until the store is post-retirement to get the value from memory.

Vector stores that use an opmask cannot be forwarded from. If your algorithm requires such behavior, you may benefit if you merge the value in a register, and then store to memory without a conditional opmask. Later loads can then forward from the merged value.

23.2.8.6 Way, Set Conflicts

The memory hierarchy determines forwarding requirements based on the address of the access. The L1 data cache uses address bits 11:6 to identify which cache set to use. Forwarding logic uses bits 11:0 and the size of the access to identify potential forwarding or conflicts between loads and stores. If there are many conflicts, performance could be degraded.

Many dynamic memory allocation routines (may vary by OS and compiler) will start large memory regions with the same pattern in the least significant 12 bits. If your access patterns touch many arrays with identical shapes (element size and dimensions) and similar indices, performance could degrade significantly due to set conflict. To void these set conflicts, it is beneficial for bits [11..6] of memory accesses to be different. For example, consider:

```
a = malloc(sizeof(double) * 10000);
b = malloc(sizeof(double) * 10000);
for (i=0; i < 10000; i++) {
    a[i] = b[i] + 0.5 * b[i-1]);
}
```

Very likely, in most OSes, the effective address of `a[]` and `b[]` will have identical lowest 12 bits, i.e., `(a & 0xfff) == (b & 0xfff)`. Some intra-loop conflict may occur with:

- `a[i]` and `b[i]` of iteration `N` collide.
- `a[i]` of iteration `N-1` and `b[i-1]` of iteration `N` collide.

There are multiple ways to offset dynamic arrays. Examples include:

- Offset the working base pointer from the malloc result by an amount of several cache lines,
- Use customized malloc() routine,
- Use posix_memalign() routine with alignment directives for each dynamic allocation to have different alignments (powers of 2 bytes: 64, 128, 256, 512, etc.) .

The HPC workload known as Leslie3D can be affected by alignment issue.

23.2.8.7 Streaming Store Versus Regular Store

When writing to memory and data is not expected to be consumed by loads immediately, it may be desirable to choose between streaming stores or regular stores (writeback). On Knights Landing microarchitecture, streaming stores may be preferable if in flat memory mode; see Section 23.1.3.

If MCDRAM is configured as cache mode, and the data being written fits in the MCDRAM cache, it is likely that standard stores will perform better. Experimenting with both options may yield non-trivial performance for your application.

23.2.8.8 Compiler Switches and Directives

When using Fortran 90 syntax, Fortran programmers should use the CONTIGUOUS attribute when appropriate. If not, the compiler may assume that incoming arrays are not contiguous, and will (potentially) replace vector load and store instructions with VGATHER and VSCATTER instructions. This can have a negative impact on performance.

Expert coders compiling with the Intel compiler can annotate their code with various pragmas. Some of the more useful ones are LOOP_COUNT, SIMD, and UNROLL. Read the documentation for these pragmas, and use them where appropriate. The compiler can produce better code when it is given more information to evaluate the cost of vectorization.

When using the Intel compilers, the compiler switch "-xMIC-AVX512" targets Knights Landing microarchitecture.

23.2.8.9 Direct Mapped MCDRAM Cache

When MCDRAM is configured in cache mode, the MCDRAM cache is a convenient way to increase memory bandwidth. As a memory side cache, it can automatically cache recently used data, and provide much higher bandwidth than what DDR memory can achieve.

The MCDRAM cache is a direct mapped cache. This means that multiple memory locations can map to a single place in the cache. Because of this, a simple optimization for a program to evaluate its memory bandwidth sensitivity is to turn on the MCDRAM cache. Some applications that heavily utilize only a few GBytes of memory footprint could see performance improvements of up to 4x. Because of the simplicity of this - no source code changes, and the large possible performance benefits, moving from DDR only to MCDRAM cache mode should be one of the first performance optimizations to try.

There are a few scenarios where enabling the cache could reduce performance. One case is when the MCDRAM cache is not able to hold the accessed working set. If an application streams through 64 GB of memory without reuse, the cost of memory access will increase due to checking the MCDRAM cache (and missing), relative to accessing DDR memory.

The caching of data in the MCDRAM direct mapped cache uses the physical address, not the linear address. Even if an address is contiguous in the linear/virtual address space, the physical addresses that the OS allocates and manages are not required to be. This can cause cache contention when a significant portion of the MCDRAM cache are used. These contentions are likely to reduce the peak memory bandwidth achievable, and vary from run to run; as how the OS allocates pages can change from run to run. The performance monitoring hardware in the Knights Landing microarchitecture provides the UNC_E_EDC_ACCESS event to compute the MCDRAM cache hit rate. It can be instructive in diagnosing this problem.

If MCDRAM cache is enabled, every modified line in the tile caches (L1 or L2 cache) must have an entry in the MCDRAM cache. If a line is evicted from the MCDRAM cache, any modified version of that line in the tile caches will writeback its data to memory, and transition to a shared state. There is a very small probability that a pair of lines that are frequently read and written will alias to the same MCDRAM set. This could cause a pair of writes that would normally hit in the tile caches to generate extra mesh traffic when using MCDRAM in cache mode. Due to this, a pair of threads could become substantially slower than the other threads in the chip. Linear to physical mapping can vary from run to run, making it difficult to diagnose.

One case in point is when two threads read and write their private stacks. Conceptually, any data location that is commonly read and written to would work, but register spills to the stack are the most frequent case. If the stacks are offset by a multiple of 16 GB (or the total MCDRAM cache size) in physical memory, they would collide into the same MCDRAM cache set. A run-time that forced all thread stacks to allocate into a contiguous physical memory region would avoid this case from occurring.

There is hardware in the Knights Landing microarchitecture to reduce the frequency of set conflicts from occurring. The probability of hitting this scenario on a given node is extremely small. The best clue to detecting this, is that a pair of threads on the same chip are significantly slower than all other threads during a program phase. Which exact threads cores in a package would experience set collision should vary from run to run, happen rarely, and only when the cache memory mode is enabled. It is very likely that a user may never encounter this on their system.

APPENDIX A

APPLICATION PERFORMANCE TOOLS

Intel offers an array of application performance tools that are optimized to take advantage of the Intel architecture (IA)-based processors. This appendix introduces these tools and explains their capabilities for developing the most efficient programs without having to write assembly code.

The following performance tools are available.

- **Compilers**
 - Intel® C++ Compiler: a high-performance, optimized C and C++ cross compiler with the capability of offloading compute-intensive code to Intel® Many Integrated Core Architecture (Intel® MIC Architecture) as well as Intel® HD Graphics, and executing on multiple execution units by using Intel® Cilk™ parallel extensions.
 - Intel® Fortran Compiler: a high-performance, optimized Fortran compiler.
- **Performance Libraries** — a set of software libraries optimized for Intel architecture processors.
 - Intel® Integrated Performance Primitives (Intel® IPP): performance building blocks to boost embedded system performance.
 - Intel® Math Kernel Library (Intel® MKL): a set of highly optimized linear algebra, Fast Fourier Transform (FFT), vector math, and statistics functions.
 - Intel® Threading Building Blocks (Intel® TBB): a C and C++ template library for creating high performance, scalable parallel applications.
 - Intel® Data Analytics Acceleration Library (Intel® DAAL): C++ and Java API library of optimized analytics building blocks for all data analysis stages, from data acquisition to data mining and machine learning. Essential for engineering high performance Big Data applications.
- **Performance Profilers** — performance profilers collect, analyze, and display software performance data for tuning CPU, GPU, threading, vectorization and MPI parallelism from the system-wide view down to a specific line of code.
 - Intel® VTune™ Amplifier XE: performance profiler.
 - Intel® Graphics Performance Analyzers (Intel® GPA) - a set of performance analyzers for graphics applications.
 - Intel® Advisor: vectorization optimization and thread prototyping.
 - Intel® Trace Analyzer and Collector: MPI communications performance profiler and correctness checker.
- **Debuggers**
 - Intel® Inspector: memory and thread debugger.
 - Intel® Application Debugger.
 - Intel® JTAG Debugger.
 - Intel® System Debugger.
- **Cluster Tools**
 - Intel® MPI Library: high-performance MPI library.
 - Intel® MPI Benchmarks: a set of MPI kernel tests to verify the performance of your cluster or MPI implementation.

The performance tools listed above can be found in the following product suites.

- **Intel® Parallel Studio XE¹**
 - Intel® Media Server Studio.
 - Intel® Systems Studio.

A.1 COMPILERS

Intel compilers support several general optimization settings, including `/O1`, `/O2`, `/O3`, and `/fast`. Each of them enables a number of specific optimization options. In most cases, `/O2` is recommended over `/O1` because the `/O2` option enables function expansion, which helps programs that have many calls to small functions. The `/O1` may sometimes be preferred when code size is a concern. The `/O2` option is on by default.

The `/Od` (`-O0` on Linux) option disables all optimizations. The `/O3` option enables more aggressive optimizations, most of which are effective only in conjunction with processor-specific optimizations described below.

The `/fast` option maximizes speed across the entire program. For most Intel 64 and IA-32 processors, the `/fast` option is equivalent to `/O3 /Qipo /Qprec-div- /fp:fast=2 /QxHost` on Windows*, `"-ipo -O3 -no-prec-div -static -fp-model fast=2 -xHost"` on Linux, and `"-ipo -mdynamic-no-pic -O3 -no-prec-div -fp-model fast=2 -xHost"` on OS X*.

All the command-line options are described in Intel® C++ Compiler documentation.

A.1.1 Recommended Optimization Settings for Intel® 64 and IA-32 Processors

Table A-1 lists some examples of recommended compiler options for generating code for Intel processors. Table A-1 also applies to code targeted to run in compatibility mode on an Intel 64 processor, but does not apply to running in 64-bit mode. For an up-to-date list see this article: <https://software.intel.com/en-us/articles/performance-tools-for-software-developers-intel-compiler-options-for-sse-generation-and-processor-specific-optimizations/>.

Table A-1. Recommended Processor Optimization Options

Need	Recommendation	Comments
Best performance on Intel processors utilizing Intel® AVX2 instructions.	• <code>/QxCORE-AVX2</code> (<code>-xCORE-AVX2</code> on Linux and Mac OS)	• Single code path.
Best performance on Intel processors utilizing Intel® AVX2 instructions.	• <code>/QaxCORE-AVX2</code> (<code>-axCORE-AVX2</code> on Linux and Mac OS)	• Multiple code paths are generated. • Be sure to validate your application on all systems where it may be deployed.
Best performance on Intel processors utilizing Intel SSE4.2 instructions.	• <code>/QxSSE4.2</code> (<code>-xSSE4.2</code> on Linux and Mac OS)	• Single code path.
Best performance on Intel processors utilizing Intel SSE4.2 instructions.	• <code>/QaxSSE4.2</code> (<code>-axSSE4.2</code> on Linux and Mac OS)	• Multiple code paths are generated. • Be sure to validate your application on all systems where it may be deployed.

¹ Details on versions and tools included can be found here: <https://software.intel.com/en-us/intel-parallel-studio-xe>.

A.1.2 Vectorization and Loop Optimization

The Intel C++ and Fortran Compiler's vectorization feature can detect sequential data access by the same instruction and transforms the code to use Intel SSE, Intel SSE2, Intel SSE3, Intel SSSE3 and Intel SSE4, depending on the target processor platform. The vectorizer supports the following features:

- Multiple data types: Float/double, char/short/int/long (both signed and unsigned), `_Complex` float/double are supported.
- Step by step diagnostics: Through the `/Qopt-report` `/Qopt-report-phase` (`-qopt-report -qopt-report-phase` on Linux and Mac OS) switch, the vectorizer can identify, line-by-line and variable-by-variable, what code was vectorized, what code was not vectorized, and more importantly, why it was not vectorized. This feedback gives the developer the information necessary to slightly adjust or restructure code, with dependency directives and restrict keywords, to allow vectorization to occur.
- Advanced dynamic data-alignment strategies: Alignment strategies include loop peeling and loop unrolling. Loop peeling can generate aligned loads, enabling faster application performance. Loop unrolling matches the prefetch of a full cache line and allows better scheduling.
- Portable code: By using appropriate Intel compiler switches to take advantage new processor features, developers can avoid the need to rewrite source code.

The processor-specific vectorizer switch options are: `/Qx<CODE>` and `/Qax<CODE>` (`-x<CODE>` and `-xa<CODE>` on Linux and Mac OS). The compiler provides a number of other vectorizer switch options that allow you to control vectorization. The latter switches require one of these switches to be on. The default is off.

A.1.2.1 Multithreading with OpenMP*

Both the Intel C++ and Fortran Compilers support shared memory parallelism using OpenMP compiler directives, library functions and environment variables. OpenMP directives are activated by the compiler switch `/Qopenmp` (`-openmp` on Linux and Mac OS). The available directives are described in the Compiler User's Guides available with the Intel C++ and Fortran Compilers. For information about the OpenMP standard, see <http://www.openmp.org>.

A.1.2.2 Automatic Multithreading

Both the Intel C++ and Fortran Compilers can generate multithreaded code automatically for simple loops with no dependencies. This is activated by the compiler switch `/Qparallel` (`-parallel` in Linux and Mac OS).

A.1.3 Inline Expansion of Library Functions (`/Oi`, `/Oi-`)

The compiler inlines a number of standard C, C++, and math library functions by default. This usually results in faster execution. Sometimes, however, inline expansion of library functions can cause unexpected results. For explanation, see the Intel C++ Compiler documentation.

A.1.4 Interprocedural and Profile-Guided Optimizations

The following are two methods to improve the performance of your code based on its unique profile and procedural dependencies.

A.1.4.1 Interprocedural Optimization (IPO)

You can use the `/Qip` (`-ip` in Linux and Mac OS) option to analyze your code and apply optimizations between procedures within each source file. Use multifile IPO with `/Qipo` (`-ipo` in Linux and Mac OS) to enable the optimizations between procedures in separate source files.

A.1.4.2 Profile-Guided Optimization (PGO)

Creates an instrumented program from your source code and special code from the compiler. Each time this instrumented code is executed, the compiler generates a dynamic information file. When you compile a second time, the dynamic information files are merged into a summary file. Using the profile information in this file, the compiler attempts to optimize the execution of the most heavily travelled paths in the program.

Profile-guided optimization is particularly beneficial for the Pentium 4 and Intel Xeon processor family. It greatly enhances the optimization decisions the compiler makes regarding instruction cache utilization and memory paging. Also, because PGO uses execution-time information to guide the optimizations, branch-prediction can be significantly enhanced by reordering branches and basic blocks to keep the most commonly used paths in the microarchitecture pipeline, as well as generating the appropriate branch-hints for the processor.

When you use PGO, consider the following guidelines:

- Minimize the changes to your program after instrumented execution and before feedback compilation. During feedback compilation, the compiler ignores dynamic information for functions modified after that information was generated.

NOTE

The compiler issues a warning that the dynamic information corresponds to a modified function.

- Repeat the instrumentation compilation if you make many changes to your source files after execution and before feedback compilation.

For more on code optimization options, see the Intel C++ Compiler documentation.

A.1.5 Intel® Cilk™ Plus

Intel Cilk Plus is an Intel C/C++ compiler extension with only 3 keywords that simplifies implementing simple loop and task parallel applications. It offers superior functionality by combining vectorization features with high-level loop-type data parallelism and tasking.

A.2 PERFORMANCE LIBRARIES

The Intel Performance Libraries implement a number of optimizations that are discussed throughout this manual. Examples include architecture-specific tuning such as loop unrolling, instruction pairing and scheduling; and memory management with explicit and implicit data prefetching and cache tuning.

The Libraries take advantage of the parallelism in the SIMD instructions using MMX technology, Intel Streaming SIMD Extensions (Intel SSE), Intel Streaming SIMD Extensions 2 (Intel SSE2), and Intel Streaming SIMD Extensions 3 (Intel SSE3). These techniques improve the performance of computationally intensive algorithms and deliver hand coded performance in a high level language development environment.

For performance sensitive applications, the Intel Performance Libraries free the application developer from the time consuming task of assembly-level programming for a multitude of frequently used functions. The time required for prototyping and implementing new application features is substantially reduced and most important, the time to market is substantially improved. Finally, applications developed with the Intel Performance Libraries benefit from new architectural features of future generations of Intel processors simply by relinking the application with upgraded versions of the libraries.

The library set includes the Intel Integrated Performance Primitives (Intel IPP), Intel Math Kernel Library (Intel MKL) and Intel Threading Building Blocks (Intel TBB).

A.2.1 Intel® Integrated Performance Primitives (Intel® IPP)

Intel Integrated Performance Primitives for Linux and Windows: IPP is a cross-platform software library which provides a range of library functions for video decode/encode, audio decode/encode, image color conversion, computer vision, data compression, string processing, signal processing, image processing, JPEG decode/encode, speech recognition, speech decode/encode, cryptography plus math support routines for such processing capabilities.

These ready-to-use functions are highly optimized using Intel® Streaming SIMD Extensions (Intel® SSE) and Intel® Advanced Vector Extensions (Intel® AVX) instruction sets. With a single API across the range of platforms, the users can have platform compatibility and reduced cost of development.

A.2.2 Intel® Math Kernel Library (Intel® MKL)

The Intel Math Kernel Library for Linux, Windows and OS X: MKL is composed of highly optimized mathematical functions for engineering, scientific and financial applications requiring high performance on Intel platforms. The functional areas of the library include linear algebra consisting of LAPACK and BLAS, Discrete Fourier Transforms (DFT), vector transcendental functions (vector math library/VML) and vector statistical functions (VSL). Intel MKL is optimized for the latest features and capabilities of the Intel® Itanium®, Intel® Xeon®, Intel® Pentium® 4, and Intel® Core2 Duo processor-based systems. Special attention has been paid to optimizing multi-threaded performance for the new Quad-Core Intel® Xeon® processor 5300 series.

A.2.3 Intel® Threading Building Blocks (Intel® TBB)

Intel TBB is a C++ template library for creating reliable, portable, and scalable parallel applications. Use Intel TBB for a simple and rapid way of developing robust task-based parallel applications that scale to available processor cores, are compatible with multiple environments, and are easier to maintain.

Intel TBB is validated and commercially supported on Windows, Linux and OS X* platforms. It is also available on FreeBSD*, IA Solaris*, Xbox* 360, and PowerPC-based systems via the open source community.

A.2.4 Benefits Summary

The overall benefits the libraries provide to the application developers are as follows:

- **Time-to-Market** — Low-level building block functions that support rapid application development, improving time to market.
- **Performance** — Highly-optimized routines with a C interface that give Assembly-level performance in a C/C++ development environment (Intel MKL also supports a Fortran interface).
- **Platform tuned** — Processor-specific optimizations that yield the best performance for each Intel processor.
- **Compatibility** — Processor-specific optimizations with a single application programming interface (API) to reduce development costs while providing optimum performance.
- **Threaded application support** — Applications can be threaded with the assurance that the Intel MKL and Intel IPP functions are safe for use in a threaded environment.

A.3 PERFORMANCE PROFILERS

Intel® serial and parallel processing profiling tools locate performance bottlenecks without recompilation and with very low overhead, and provide quick access to scaling information for faster and improved decision making. The profiling tools enable evaluation of all sizes of Intel® processor based systems, from embedded systems through supercomputers, to help you improve application performance.

A.3.1 Intel® VTune™ Amplifier XE

Intel® VTune™ Amplifier XE¹ is a powerful threading and performance optimization tool for Windows and Linux. Use the VTune Amplifier to fine-tune for optimal performance, ensuring cores are fully exploited and new processor capabilities are supported to the fullest.

The sections that follow briefly describe the major features of the VTune Amplifier. For more details on these features, run the VTune Amplifier and see the online documentation.

A.3.1.1 Hardware Event-Based Sampling Analysis

VTune Amplifier introduces a set of microarchitecture analysis types based on the event-based sampling data collection and targeted for the Intel® Core™ 2 processor family, processors based on the Intel processors. Depending on the analysis type, the VTune Amplifier monitors a set of hardware events and displays collected data as raw event count (for example, cache misses, clock ticks, and instructions retired) and as performance metrics. Each metric is an event ratio with its own threshold values. As soon as the performance of a program unit per metric exceeds the threshold, the VTune Amplifier marks this value as a performance issue (in pink) and provides recommendations how to fix it.

Lists of available performance-monitoring events can be found at: <https://perfmon-events.intel.com/>.

A.3.1.2 Algorithm Analysis

VTune Amplifier introduces a set of algorithm analysis types based on the user-mode sampling and tracing collection:

- **Basic Hotspots** analysis that helps understand the application execution flow and identify sections of code that took a long time to execute (hotspots). A large number of samples collected at a specific process, thread, or module can imply high processor utilization and potential performance bottlenecks. Some hotspots can be removed, while other hotspots are fundamental to the application functionality and cannot be removed. VTune Amplifier creates a list of functions in your application ordered by the amount of time spent in a function. It also detects the call stacks for each of these functions so you can see how the hot functions are called.
- **Locks and Waits** analysis that helps identify the cause of the ineffective processor utilization. One of the most common problems is threads waiting too long on synchronization objects (locks). Performance suffers when waits occur while cores are under-utilized. During the Locks and Waits analysis you can estimate the impact each synchronization object introduces to the application and understand how long the application was required to wait on each synchronization object, or in blocking APIs, such as sleep and blocking I/O.
- **Concurrency** analysis that helps identify hotspot functions where processor utilization is poor. When cores are idle at a hotspot, you have an opportunity to improve performance by getting those cores working for you.

A.3.1.3 Platform Analysis

You may enable the VTune Amplifier to collect platform-wide metrics for applications that use a Graphics Processing Unit (GPU) for rendering, video processing, and computations. Use the CPU/GPU Concurrency analysis as a starting point to understand the code execution on the various CPU and GPU cores in your system and identify whether your target application is GPU or CPU bound.

A.4 THREAD AND MEMORY CHECKERS

Intel® tools combine threading and memory error checking into one powerful error checking tool to help increase the reliability, security, and accuracy of your applications.

¹ For additional information, see: <http://software.intel.com/en-us/articles/intel-vtune-amplifier-xe/?wapkw=vtune>

A.4.1 Intel® Inspector

Intel® Inspector provides thread debugging analysis for higher performing parallel applications (find: data races, deadlocks, thread and sync APIs used and memory accesses between threads) and memory checking analysis for serial and parallel applications (find: memory leaks and memory corruption, memory allocation and deallocation API mismatches, and inconsistent memory API usage).

Intel® Inspector enhances developer productivity and facilitates application reliability by effectively finding crucial memory and threading defects early in the development cycle. It gives detailed insights into application memory and threading behavior to improve application reliability. The powerful thread checker and debugger makes it easier to find latent errors on the executed code path. It also finds intermittent and non-deterministic errors, even if the error-causing timing scenario does not happen. In addition, developers can test their code more often, without the need to use special test builds or compilers.

A.5 VECTORIZATION ASSISTANT

A.5.1 Intel® Advisor

The Intel Advisor is the vectorization assistant and threading prototyping tool that simplifies threading, parallelizing, and vectorizing your source code by identifying those areas in your applications where vectorization and/or threading parallelism would have the greatest impact.

A.6 CLUSTER TOOLS

The Intel Parallel Studio XE, Cluster Edition helps you develop, analyze and optimize performance of parallel applications for clusters using IA-32, IA-64, and Intel® 64 architectures. The Cluster Edition includes the following tools for developing code for clusters: Intel® Trace Analyzer and Collector, Intel MPI Library, and Intel MPI Benchmarks.

A.6.1 Intel® Trace Analyzer and Collector

The Intel® Trace Analyzer and Collector¹ helps to provide information critical to understanding and optimizing application performance on clusters by quickly finding performance bottlenecks in MPI communication. It supports Intel® architecture-based cluster systems, features a high degree of compatibility with current standards, and includes trace file idealization and comparison, counter data displays, performance assistant and an MPI correctness checking library. Analyze MPI performance, speed up parallel application runs, locate hotspots and bottlenecks, and compare trace files with graphics providing extensively detailed analysis and aligned timelines.

A.6.1.1 MPI Performance Snapshot

The MPI Performance Snapshot (MPS) is a scalable lightweight performance tool for MPI applications. It collects a variety of MPI application statistics (such as communication, activity, and load balance) and presents it in an easy-to-read format. MPS combines lightweight statistics from the Intel® MPI Library with OS and hardware-level counters to provide you with high-level overview of your application. The tool is provided as part of the Intel® Trace Analyzer and Collector installation.

A.6.2 Intel® MPI Library

The Intel MPI Library is a multi-fabric message passing library that implements the Message Passing Interface, v2 (MPI-2) specification. It provides a standard library across Intel® platforms. The Intel MPI

¹ Intel® Trace Analyzer and Collector is only available as part of Intel® Cluster Studio or Intel® Cluster Studio XE.

Library supports multiple hardware fabrics including InfiniBand, Myrinet*, and Intel® True Scale Fabric. Intel® MPI Library covers all your configurations by providing an accelerated universal, multi-fabric layer for fast interconnects via the Direct Access Programming Library (DAPL) methodology. Develop MPI code independent of the fabric, knowing it will run efficiently on whatever fabric is chosen by the user at runtime.

Intel MPI Library dynamically establishes the connection, but only when needed, which reduces the memory footprint. It also automatically chooses the fastest transport available. The fallback to sockets at job startup avoids the chance of execution failure even if the interconnect selection fails. This is especially helpful for batch computing. Any products developed with Intel MPI Library are assured run time compatibility since your users can download Intel's free runtime environment kit. Application performance can also be increased via the large message bandwidth advantage from the optional use of DAPL inside a multi-core or SMP node.

A.6.3 Intel® MPI Benchmarks

The Intel MPI Benchmarks will help enable an easy performance comparison of MPI functions and patterns, the benchmark features improvements in usability, application performance, and interoperability.

A.7 INTEL® ACADEMIC COMMUNITY

You can find information on classroom training offered by the Intel Academic Community at <https://software.intel.com/en-us/articles/intel-academic-community-showcase>. Find general information for developers at <http://software.intel.com/en-us/>.

APPENDIX B

USING PERFORMANCE MONITORING EVENTS

Performance monitoring provides means to characterize the interaction between programmed sequences of instructions and microarchitectural sub-systems. Performance monitoring facilities are described in Chapter 19 of the *Intel® 64 and IA-32 Architectures Software Developer's Manual, Volume 3B*. Performance-monitoring events are described at <https://perfmon-events.intel.com/>.

The first section of this appendix (Top-Down Analysis Method) provides information on the Top-Down Microarchitecture Analysis (TMA) method for analyzing performance bottlenecks when tuning for Intel microarchitectures. Sections B.1.1 through B.1.7 present a generalized formalism that can adapt to several recent Intel® microarchitectures. The remaining subsections have instantiations of TMA for the Golden Cove, Ice Lake, Cascade Lake, and Skylake, including examples where it applies.

The rest of this chapter has performance monitoring information for previous generations of Intel microarchitectures.

B.1 TOP-DOWN ANALYSIS METHOD

The section describes the Top-down Microarchitecture Analysis (TMA) method for identifying performance bottlenecks in out-of-order cores. The method's abstraction and the spirit of the hierarchical technique can apply to many out-of-order processors.

TMA simplifies cycle-accounting (the process of identifying costs of performance bottlenecks, also called CPI breakdown) using microarchitecture-abstracted metrics organized in one hierarchy.

General TMAMTMA Hierarchy for Out-of-Order Microarchitectures depicts the hierarchical approach to classify performance bottlenecks common to modern out-of-order microarchitectures. Using TMA, the high-learning curve associated with each microarchitecture generation is replaced by a structured drill-down that quickly guides the user to true performance limiters. This enables analyzing performance without requiring knowledge of every detail of the microarchitecture.

The advantage of this top-down hierarchical framework is a structured approach to drill down and guide you toward the likely area of microarchitecture to investigate. Weights are assigned to nodes in the tree to enable a focus analysis efforts on issues that matter and disregard minor issues.

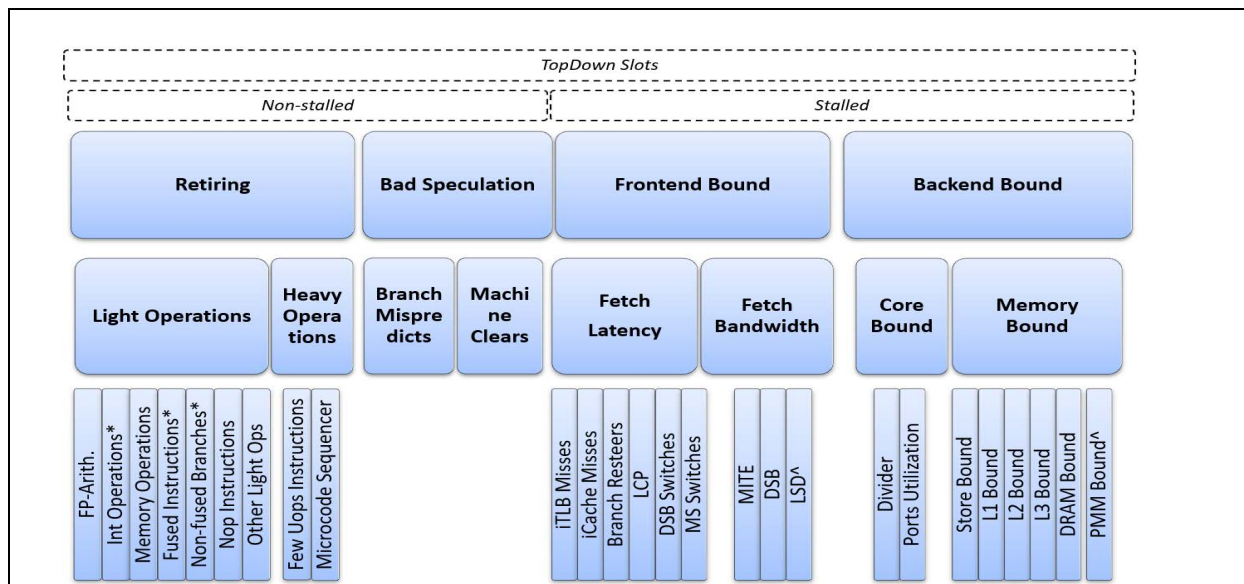

Figure B-1. General TMA Hierarchy for Out-of-Order Microarchitectures

For example, if instruction fetch issues significantly hurt an application, TMA categorizes it as Frontend Bound at the tree's top level. A user/tool can drill down and focus only on the Frontend sub-tree. The drill down is recursively performed until a tree-leaf is reached. A leaf can point to a specific stall of the workload or denote a subset of issues with a common micro-architectural symptom likely to limit the application's performance.

TMA was first developed¹ in conjunction with the performance monitoring capability of the Sandy Bridge microarchitecture. The methodology is refined with subsequent generations to support multiple microarchitecture generations and enhanced by subsequent PMU capabilities. Please refer to the TMA electronic file at <https://download.01.org/perfmon/> for details on the complete hierarchy and its nodes, additional useful, informative metrics, metric descriptions, event ratios per generation, or specific events.

B.1.1 Top-Level

At the top-level, TMA classifies pipeline slots into four main categories:

- Frontend Bound
- Backend Bound
- Bad Speculation
- Retiring

The latter two denote non-stalled slots while the former two indicate stalls, as illustrated in Figure B-1 above. Figure B-2 depicts a simple decision tree to start the drill-down process.

- If some operation utilizes a slot, it will be classified as Retiring or Bad Speculation, depending on whether it eventually gets retired (committed).
 - Unused slots are classified as Backend Bound if the back end portion of the pipeline is unable to accept more operations (a.k.a. back-end stall²), or
 - Frontend Bound: indicating no operations (uops) delivered while there was no back-end stall.

1. A Top-Down Method for Performance Analysis and Counters Architecture, Ahmad Yasin. In IEEE International Symposium on Performance Analysis of Systems and Software, ISPASS 2014. <http://bit.ly/tma-ispss14>.

2. *ibid.*

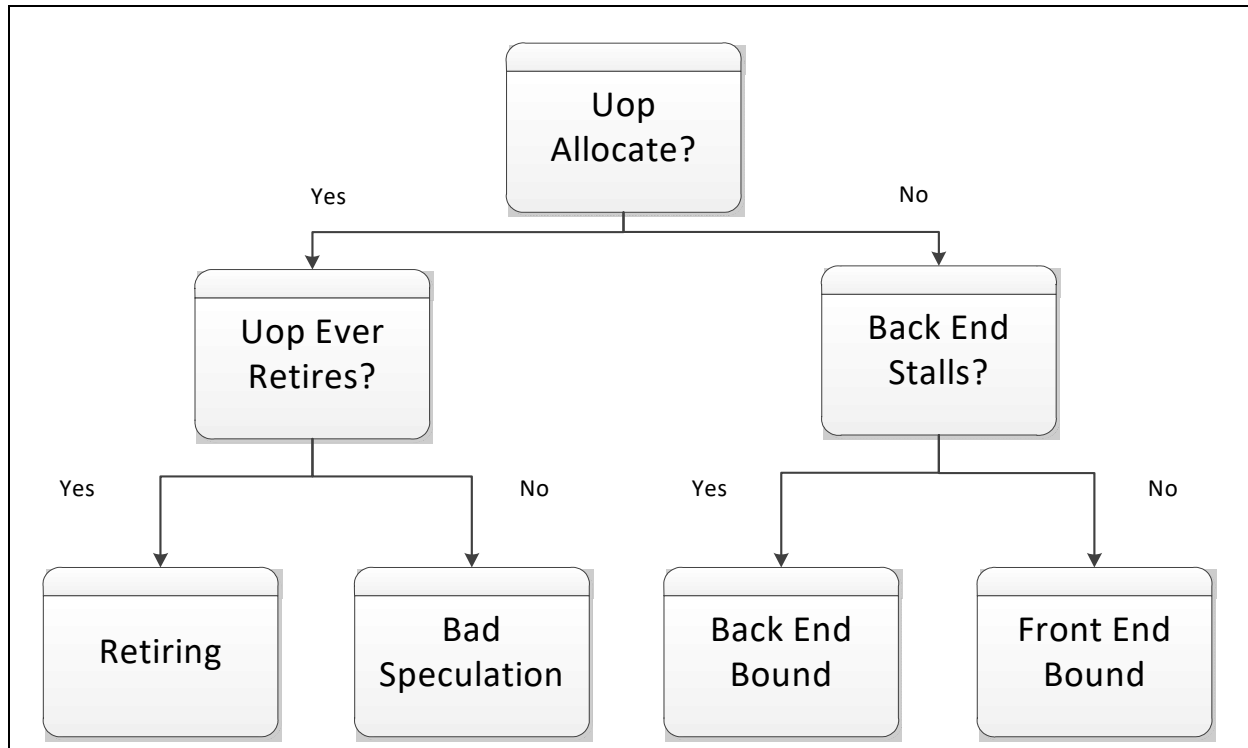

Figure B-2. TMA's Top Level Drill Down Flowchart

The single entry point of division at a pipeline's issue stage (allocation stage) makes the four categories additive to the total possible slots. The classification at slots granularity (sub-cycle) makes the breakdown very accurate and robust for superscalar cores, which is necessary at the top level.

Retiring denotes slots utilized by "good operations." Ideally, you want to see all slots attributed here since it correlates with Instructions Per Cycle (IPC). Nevertheless, a high Retiring fraction does not necessarily mean there is no room for speedup.

Bad Speculation denotes slots wasted due to all aspects of incorrect speculations. It includes: (a) slots of operations that do not eventually retire and (b) slots where the issue pipeline was blocked due to recovery from earlier mis-speculations. Note there is a third portion covered by Branch_Restesters¹. This category can be split per type of speculation. For example, Branch Mispredicts and Machine Clears cover control-flow and data mis-speculation, respectively.

Frontend Bound denotes when the pipeline's Frontend under-supplies the Backend. The Frontend is the pipeline portion responsible for delivering operations to be executed later by the Backend. This category is further classified into Fetch Latency (for example, ICache or ITLB misses) and Fetch Bandwidth (for instance, sub-optimal decoding).

Backend Bound denotes remaining stalled slots due to a lack of required Backend resources. It is split into Memory Bound, which reflects execution stalls due to the memory subsystem, and Core Bound, which demonstrates either pressure on the execution units (compute bound) or lack of Instructions-Level-Parallelism (ILP).

The following sections provide more details on these categories and nodes in subsequent levels of the hierarchy.

B.1.2 Frontend Bound

The **Frontend** denotes the pipeline portion where the branch predictor predicts the next address to fetch, streams of code bytes are fetched from ICache, parsed into instructions, and decoded into micro-ops that can be executed later by the back end. **Frontend Bound** denotes when the **Frontend** of the processor core under-supplies the **Backend**. There were fetch bubbles when the **Backend** was ready to accept uops (micro-ops).

Dealing with **Frontend** issues is tricky without **TMA**, as they occur at the beginning of the long and buffered pipeline. This often means transient issues will not dominate the actual performance, and you should investigate these issues only when **Frontend Bound** is flagged at the top level. In many cases, the front-end supply bandwidth can dominate the performance, especially when high IPC applies. This has led to the addition of dedicated units to hide the fetch pipeline latency and sustain required bandwidth, such as the Loop Stream Detector (LSD) and Decoded ICache (DSB).

TMA further distinguishes between latency and bandwidth Frontend stalls:

- An ICache miss is classified under **Fetch Latency**.
- Inefficiency in the instruction decoders is classified under **Fetch Bandwidth**.

Note that these metrics are defined in the top-down approach: **Fetch Latency** accounts for cases that lead to fetch starvation (the symptom of no uop delivery) regardless of what has caused that. Familiar i-cache and i-TLB misses fit here, but not only these. **Branch Resteers** accounts for fetch delays following pipeline flushes. Pipeline flushes can be caused by clear events such as branch misprediction or memory nukes. **Branch Resteers** are tightly coupled with Bad Speculation.

The methodology further classifies bandwidth issues per fetch unit, inserting uops to the Micro-Op-Queue (see Figure 2-6). Instruction decoders translate commonly-used x86 instructions into micro-ops that the rest of the machine understands; that would be one fetch unit. Some x86 instructions require sophisticated micro-op flows, like CPUID, relying on the MSR0M to supply the long micro-op flows; that would be the 2nd fetch unit, and so on. Different fetch units may have different supply bandwidths from one generation to another. Figure 2-6 provides additional details for the Skylake microarchitecture.

All products do not support the LSD (^) node in Figure B-1.

B.1.3 Backend Bound

Backend Bound reflects slots where no micro-ops are being delivered at the issue pipeline, due to a lack of required resources for accepting them in the back end. Examples of performance issues in this category include data-cache misses or stalls due to the overloaded divider unit.

Backend Bound is split into **Memory Bound** and **Core Bound**. This is achieved by breaking down back-end stalls based on execution units' occupation at every cycle. To sustain a maximum IPC, it is necessary to keep execution units busy. For example, in a four-slot-wide machine, if three or fewer micro-ops are executed in a steady state of some code, this would prevent it from achieving an optimal IPC of 4. These sub-optimal cycles are called ExecutionStalls.

B.1.4 Memory Bound

Memory Bound corresponds to execution stalls related to the cache and memory subsystems. These stalls usually manifest with execution units starved after a short while, like in the case of a load missing all caches. Many recent generations of Intel Core processors have three levels of cache hierarchy to hide external memory latency. The first level has a data cache (L1D). L2 is the second level shared instruction and data cache, which is private to each core. L3 is shared among all the processor cores within a physical package.

The out-of-order scheduler can dispatch micro-ops into multiple execution units for execution. While these micro-ops were executing in-flight, some of the memory access latency exposure for data can be hidden by keeping the execution units busy with useful micro-ops that do not depend on pending memory accesses. Thus for common cases, the real penalty for memory access is when the scheduler

has nothing ready to feed the execution units. It is likely that further micro-ops are either waiting for the pending memory access or depend on other unready micro-ops.

ExecutionStalls span several sub-categories, each associated with a particular cache level and depending on the demanded data satisfied by the respective cache level. In some situations, an ExecutionStall can experience significant delay, greater than the nominal latency of the corresponding cache level, while no demand-load is missing that cache level.

For example, the L1D cache often has short latency which is comparable to ALU stalls (or waiting for completion of some commonly-used execution units like floating-point adds/multiplies or integer multiplies). Yet in certain scenarios, like a load blocked from forward data from an earlier store to an overlapping address, this load might suffer a high effective latency while eventually being satisfied by L1D. In such a scenario, the in-flight load will last a long time without missing L1D. Hence, it gets tagged under L1 Bound. Load blocks due to 4K Aliasing is another scenario with the same symptom.

- ExecutionStalls related to store operations are also treated in the **Store Bound** category. Store operations are buffered and executed post-retirement due to memory ordering requirements. Typically, store operations have little impact on performance, but they cannot be neglected entirely. **TMA** defines Stores Bound as a fraction of cycles with low execution ports utilization and a high number of stores consuming resources needed to buff the stores.

Data TLB misses are categorized under various Memory Bound sub-nodes. For example, if a TLB translation is satisfied by L1D, it is tagged under **L1 Bound**.

- A simple heuristic is used to distinguish **MEM Bandwidth** and **MEM Latency** under **DRAM Bound**. The heuristic uses the occupancy of requests pending on data return from the memory controller. Whenever the occupancy exceeds a high threshold, say 70% of the max number of requests, the memory controller can serve simultaneously; **TMA** flags this as potentially limited by memory bandwidth. The remainder fraction will be attributed to memory latency.

B.1.5 Core Bound

Core Bound corresponds to pressure on the execution units or lack of Instructions-Level-Parallelism (ILP) in your program. Core bound stalls can either manifest with short execution starvation periods, or with sub-optimal execution port utilization, which makes it more challenging to identify. For example, a long latency divide operation might serialize execution. In contrast, pressure on an execution port that serves specific varieties of micro-ops might manifest as a small number of ports utilized in a cycle.

Core Bound issues can often be mitigated with better code generation. For example, a sequence of dependent arithmetic operations would be classified as Core Bound. A compiler may relieve this stall with better instruction scheduling. Vectorization can mitigate Core Bound issues as well.

B.1.6 Bad Speculation

Bad Speculation reflects slots wasted due to incorrect speculations. These include two portions:

- Slots used to issue micro-ops that do not eventually retire.
- Slots in which the issue pipeline was blocked due to recovery from earlier mis-speculations.

For example, this category accounts for micro-ops issued in the shadow of a mispredicted branch. Note the third portion of a misprediction penalty deals with how quick is the fetch from the correct target. This is accounted for in **Branch Resteers** as it may overlap with other front-end stalls.

Having a Bad Speculation category at the Top Level is a crucial principle in **TMA**. It determines the fraction of the workload under analysis that is affected by incorrect execution paths, which in turn dictates the accuracy of observations listed in other categories. Furthermore, this permits nodes at lower levels to use of some of the many traditional performance counter events, despite most of those counter events counting speculatively. Hence, it would be best if you treated a high value in Bad Speculation as a “red flag” that needs to be investigated before looking at other categories. In other words, minimizing Bad Speculation improves the processor resource utilization and increases confidence in metrics reported throughout the hierarchy.

TMA further classifies Bad Speculation into **Branch Mispredicts** and **Machine Clears**, with similar symptoms where the pipeline is flushed. Branch misprediction applies when the BPU incorrectly predicts the branch direction and target. Memory Order Machine Clears (for example, due to memory disambiguation) are a subset of Machine Clears. The next steps to the analysis of these issues can be completely different—the first deals with making the program control flow friendlier to the branch predictor. The latter often points to unexpected situations such as memory ordering machine clears or self-modifying code.

B.1.7 Retiring

This category reflects slots utilized by “good micro-ops” – issued micro-ops that get retired expeditiously without performance bottlenecks. Ideally, all slots attributed to the Retiring category should be seen; that is, Retiring 100% of slots corresponds to hitting the maximal micro-ops retired per cycle of the given microarchitecture. For example, assuming one instruction is decoded into one micro-op, Retiring of 50% in one slot means an IPC of 2 was achieved in a four-wide machine. In other words, maximizing the Retiring category increases the IPC of your program.

Nevertheless, a high Retiring value does not necessarily mean there is no room for more performance. Heavy Operations, like Floating Point (FP) assists, typically hurt performance and can be avoided. They are isolated under **Microcode Sequencer** in order to bring it to your attention.

A high Retiring value for non-vectorized code may be an excellent hint to vectorize the code. Doing so lets more operations to be completed by single instruction/micro-op, hence improving performance. TMA further breaks down the Retiring->Light Operations category into **FP Arith**, with **FP Scalar** and **FP Vector** operations distinction in level 4 (omitted in Figure B-1). For more details see the Matrix-Multiply use-case of the paper².

B.1.8 Golden Cove Microarchitecture

All nodes with asterisks (*) in Figure B-1 are introduced by the Golden Cove Microarchitecture.

B.1.9 Ice Lake Microarchitecture

The Ice Lake Microarchitecture supports a single “Branch Instructions” node replacing “Fused Instructions” and “Non-fused Branches” in Figure B-1.

B.1.10 Optane Persistent Memory

The App Direct Mode the Intel® Optane™ DC Persistent Memory Modules introduced by the Cascade Lake server products are supported through the PMM_Bound node (^) in Figure B-1.

B.1.11 Skylake Microarchitecture

The performance monitoring capabilities in the Skylake microarchitecture is significantly enhanced over prior generations. TMA benefits directly from the enhancement in the breadth of available counter events and in Processor-Event-Based Sampling (PEBS) capabilities. TMA hierarchy supported by the Skylake microarchitecture’s support for TMA, where the boxes in green indicates Precise events are available.

The Intel Vtune Performance Analyzer allows users to apply TMA on many Intel microarchitectures. The reader may wish to consult the white paper available at <https://software.intel.com/en-us/articles/how-to-tune-applications-using-a-top-down-characterization-of-microarchitectural-issues>, and the use cases in the white paper for additional details.

B.1.11.1 TMA Use Case 1

Section 15.15.1 describes techniques for optimizing floating-point calculations involving latency and throughput considerations of FP MUL, FP ADD and FMA instructions. There are no explicit performance counter events that can directly detect exposures of latency issues of FP_ADD and FP_MUL instructions.

TMA may be used to figure out when this performance issue is likely to be a performance limiter.

If the primary bottleneck is Backend_Bound->Core_Bound->Ports_Utilization and there is a significant measure in the GFLOPs metric, the user code may be hitting this issue. The user may consider optimizations listed in Section 15.15.1.

B.1.11.2 TMA Use Case 2

Section 15.3.1 describes possible performance issues of executing SSE code while the upper YMM state is dirty in Skylake Microarchitecture. To detect the performance issue associated with partial register dependence and associated blend cost on SSE code execution, TMA can be used to monitor the rate of mixture of SSE operation and AVX operation on performance-critical SSE code whose source code did not directly execute AVX instructions.

If the primary bottleneck is Backend_Bound->Core_Bound, and there is a significant measure in the Mixing_Vectors metric, it is possible that the presence of Vector operation with mis-matched vector width was due to the extra blend operation on the upper YMM registers.

The Mixing_Vectors metric requires the UOPS_ISSUED.VECTOR_WIDTH_MISMATCH event that is available in the Skylake Microarchitecture. This event count Blend Uops was inserted at the issue stage to preserve upper bits of vector registers. Additionally, the metric uses the UOPS_ISSUED.ANY, which is common in recent Intel microarchitectures, as the denominator. event counts the total number of Uops at the issue stage.

The Mixing_Vectors metric gives the percentage of injected blend uops out of all uops issued. Usually, a Mixing_Vectors over 5% is worth investigating.

$$\text{Mixing_Vectors}[\%] = 100 * \text{UOPS_ISSUED.VECTOR_WIDTH_MISMATCH} / \text{UOPS_ISSUED.ANY}$$

Note that the actual penalty may vary as it stems from the additional data-dependency on the destination register the injected blend operations add.

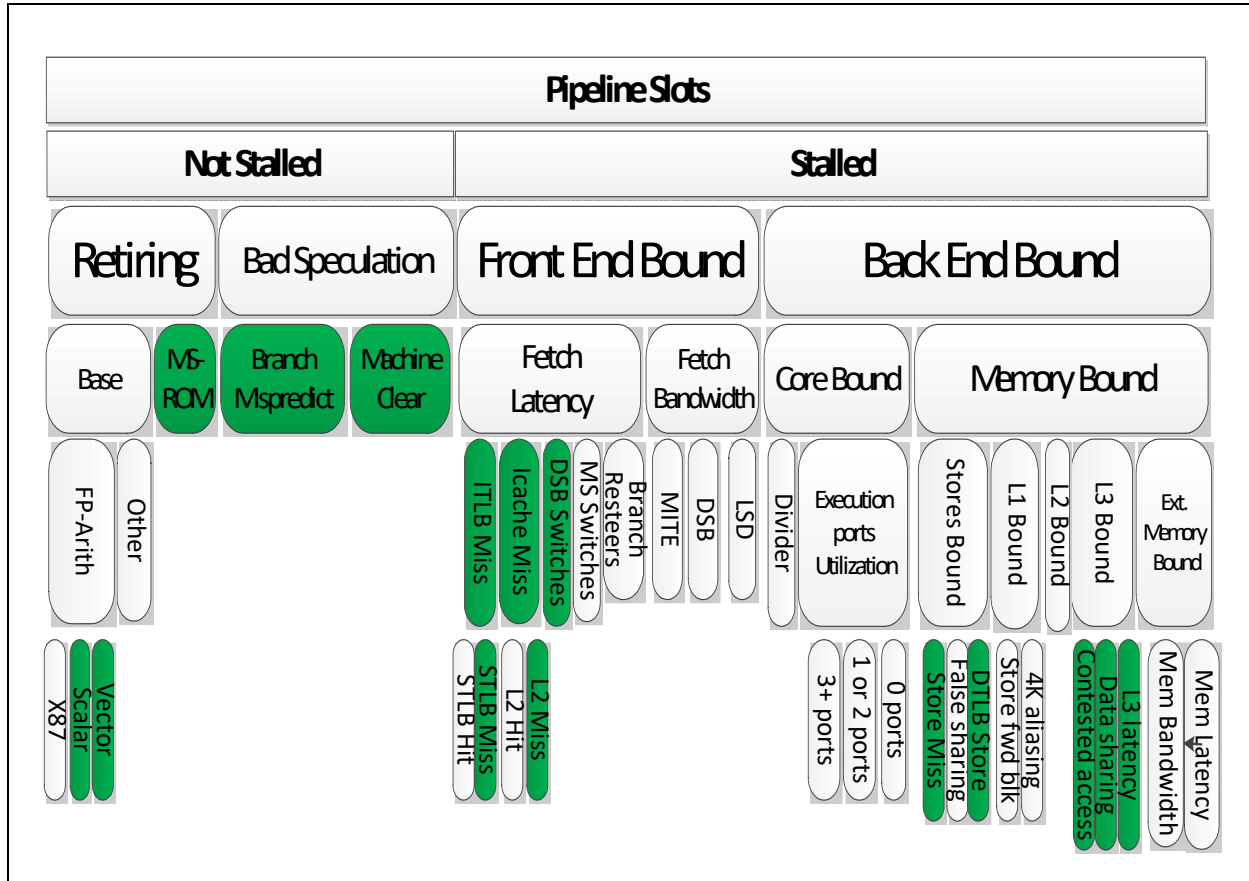

Figure B-3. TMA Hierarchy and Precise Events in Skylake

B.2 PERFORMANCE MONITORING AND MICROARCHITECTURE

This section provides information on performance monitoring hardware and terminology related to the Silvermont, Airmont and Goldmont microarchitectures. The features described here may be specific to individual microarchitecture, as indicated in Table B-1.

Table B-1. Performance Monitoring Taxonomy

Name	Description	Applicable Microarchitectures
L2Q, XQ	<p>When a memory reference misses the L1 data cache, the request goes to the L2 Queue (L2Q). If the request also misses the L2 cache, it is sent to the XQ, where it waits for an opportunity to be issued to memory across the Intra-Die Interface (IDI) link. Note that since the L2 is shared between a pair of processor cores, a single L2Q is shared between those two cores. Similarly, a single XQ for a pair of processor cores is situated between the L2Q and the IDI link.</p> <p>The XQ will fill up when the response rate from the IDI link is lower, at which new requests arrive at the XQ. The event <code>L2_reject_XQ</code> indicates that a request cannot move from the L2 Queue to the XQ because the XQ is full, signaling that the memory system is oversubscribed.</p>	Silvermont, Airmont, Goldmont
Core Reject	<p>The <code>core_reject</code> event indicates that a request from the core cannot be accepted at the L2Q. However, there are several additional reasons why a request might be rejected from the L2Q. Beyond rejecting a request because the L2Q is full, a request from one core can be rejected to maintain fairness to the other core. One core is not permitted to monopolize the shared connection to the L2Q/cache/XQ/IDI links, and might have its requests rejected even when room is available in the L2Q. In addition, if the request from the core is a dirty L1 cache eviction, the hardware must ensure that this eviction does not conflict with any pending request in the L2Q. (pending requests can include an external snoop). In a conflict event, the dirty eviction request might be rejected even when there is room in the L2Q.</p> <p>Thus, while the <code>L2_reject_XQ</code> event indicates that the request rate to memory from both cores exceeds the response rate of the memory, the <code>core_reject</code> event is more subtle. It can either indicate that the request rate to the L2Q exceeds the response rate from the XQ, or that the request rate to the L2Q exceeds the response rate from the L2. It can also either indicate that one core is attempting to request more than its fair share of response from the L2Q, or be an indicator of conflict between dirty evictions and other pending requests.</p> <p>In short, the <code>L2_reject_XQ</code> event indicates memory oversubscription. The <code>core_reject</code> event can indicate memory oversubscription, L2 oversubscription, rejection of a core's requests to insure fairness to the other core, or a conflict between dirty evictions and other pending requests.</p>	Silvermont, Airmont, Goldmont
Divider Busy	<p>The divide unit cannot accept a new divide uop when it is busy processing a previously dispatched divide uop. The "<code>CYCLES_DIV_BUSY.ANY</code>" event will count cycles that the divide unit is busy, irrespective of whether or not another divide uop is waiting to enter the divide unit (from the RS). The event will count cycles while a divide is in progress, even if the RS is empty.</p>	Silvermont, Airmont, Goldmont

Table B-1. Performance Monitoring Taxonomy

Name	Description	Applicable Microarchitectures
BACLEAR	<p>Shortly after decoding an instruction and recognizing a branch/call/jump/ret instruction, a Branch Address Calculator Clear (BACLEAR) event can occur. Possible causes of a BACLEAR include predicting the wrong target of a direct branch or not predicting a branch at that instruction location.</p> <p>A BACLEAR causes the Frontend to restart fetching from a different location. While BACLEAR has similarities to a branch mispredict signaled from the execute part of the pipeline, it is not counted as a BR_MISP_RETIRED event or noted as a mispredict in the LBRs (where LBRs report mispredict). Branch mispredicts and BACLEARs are similar in that they restart the Frontend to begin instruction fetch at a new target location and flush some speculative work. However, a branch mispredict must flush partially completed instructions from both the Frontend and back end. Since a BACLEAR occurs right at decode time, it flushes instruction bytes and not yet fully decoded instructions. Recovery after a BACLEAR is less complicated and faster than recovery after a branch mispredict.</p>	Silvermont, Airmont, Goldmont
Front end Bottleneck	<p>The front-end is responsible for fetching the instruction, decoding it into micro-ops (uops) and putting those uops into a micro-op queue to be consumed by the back end. The back end then takes these micro-ops and allocates the required resources. When all resources are ready, micro-ops are executed. A front end bottleneck occurs when the front end of the machine is not delivering uops to the back-end, and the back end is not stalled. Cycles where the back end is not ready to accept micro-ops from the front end should not be counted as front end bottlenecks even though such back end bottlenecks will cause allocation unit stalls, eventually forcing the front end to wait until the back end is ready to receive more uops.</p>	Silvermont, Airmont, Goldmont
NO_ALLOC_CYCLES	<p>Frontend issues can be analyzed using various sub-events within this event class.</p>	Silvermont, Airmont
UOPS_NOT_DELIVERED.ANY	<p>The UOPS_NOT_DELIVERED.ANY event measures front end inefficiencies to identify if the machine is truly front end bound. Some examples of Frontend inefficiencies are: ICache misses, ITLB misses, and decoder restrictions that limit the Frontend bandwidth.</p>	Goldmont
ICache	<p>Requests to Instruction Cache (ICache) are made in a fixed-size unit called a chunk. There are multiple chunks in a cache line, and multiple accesses might be made to a single cache line.</p> <p>In the Goldmont microarchitecture, the event strives to count on a cache line basis so that multiple fetches to a single cache line count as one ICACHE.ACCESS and either one HIT or one MISS. The event counts specifically when straight line code crosses the cache line boundary, or when a branch target is on a new line. This event is highly speculative, with bytes being fetched before being decoded, executed or retired. The speculation occurs in straight line code and in the presence of branches. Consequently, ICACHE statistics cannot be deduced by examining the number of retired instructions.</p> <p>In the Silvermont microarchitecture, ICACHE events (HIT, MISS) count at a different granularity.</p>	Goldmont

Table B-1. Performance Monitoring Taxonomy

Name	Description	Applicable Microarchitectures
ICache Access	<p>An ICache fetch accesses an fixed-size aligned chunk. A request to fetch a specific chunk from the instruction cache might occur multiple times due to speculative execution. It may be possible that the same chunks requested multiple times while outstanding. However, an instruction fetch miss is only counted once and is not counted every cycle while outstanding.</p> <p>After an ICache miss fetches the line, another request to the same cache line is likely to be made and counted as a hit. The number “hits” plus “misses” does therefore not equal to the number of accesses.</p> <p>From a software perspective, the ICache miss count should be subtracted from the ICache hit count to get her number of true ICache hits.</p>	Silvermont, Airmont, Goldmont
Last Level Cache References, Misses	<p>On processors that do not have L3, L2 is the last level cache. The architectural performance event to count LLC references and misses are also known as L2_REQUESTS.ANY and L2_REQUESTS.MISS.</p>	Silvermont, Airmont, Goldmont
Machine Clear	<p>Many conditions might cause a machine clear, including the receipt of an interrupt, or a trap or a fault. All such conditions, including but not limited to Memory Ordering (MO), Self or Cross Modifying Code (SMC) and Floating Point assist (FP) are captured in the MACHINE_CLEAR.ANY event. Additionally, some conditions can be specifically counted (i.e. SMC, MO, FP). However, the sum of SMC, MO and FP machine clears will not necessarily equal the number of ANY.</p>	Silvermont, Airmont, Goldmont
MACHINE_CLEAR.FP_ASSIST	<p>The floating point execute unit can properly produce the correct output bits most of the time. On rare occasions it needs help. A machine clear is asserted against the instruction to provide that help. After the machine clear, the front end of the machine starts delivering instructions to determine which FP operation was asked for. The instructions will perform extra work to produce the correct FP result. For example, if the result was a floating point denormal, sometimes the hardware asks the help to produce the correctly rounded IEEE compliant result.</p>	Silvermont, Airmont, Goldmont
MACHINE_CLEAR.SMC	<p>Self Modifying Code (SMC) refers to a piece of code that wrote to the instruction stream ahead of where the machine will execute. In the Silvermont microarchitecture, the processor detects SMC in a 1K aligned region. A detected SMC condition causes a machine clear assist and will flush the pipeline.</p> <p>Writing to memory within 1K of where the processor is executing can trigger the SMC detection mechanism and cause a machine clear. Since the machine clear allows the store pipeline to drain, when a front end restart occurs, the correct instructions after the write will be executed.</p>	Silvermont, Airmont, Goldmont

Table B-1. Performance Monitoring Taxonomy

Name	Description	Applicable Microarchitectures
MACHINE_CLEAR.MO	<p>Memory order machine clear happens when a snoop request occurs and the machine is uncertain if memory ordering will be preserved. For instance, consider two loads: one to address X followed by another to address Y in the program order. Both loads were issued; however, load to Y completes first. and all the dependent ops and data on and by this load continue together. Load to X waits for the data. Simultaneously, another processor writes to the same address Y and causes a snoop to address Y. This presents a problem. The load to Y received the old value, but X is not finished loading. The other processor saw the loads in a different order by not consuming the latest value from the store to address Y. Everything from the load must be undone to address Y so the post-write data may be seen.</p> <p>Note: Without other pending reads, load Y does not require undoing. The ordering problem is caused by the unfinished load to X.</p>	Silvermont, Airmont, Goldmont
MACHINE_CLEAR.DISAMBIGUATION	<p>Disambiguation machine clear is triggered due to a younger load passing an older store to the same address, but whose address wasn't known when the younger load executed speculatively.</p>	Goldmont
Page Walk	<p>When a translation of linear address to physical address cannot be found in the Translation Look-aside Buffer (TLB), dedicated hardware must retrieve the physical address from the page table and other paging structures if needed. After the page walk, the translation is stored in the TLB for future use.</p> <p>Since paging structures are stored in memory, the page walk can require multiple memory accesses. These accesses are considered part of demand data even if the page walk is to translate an instruction reference. The number of cycles for a page walk is variable, depending on how many memory accesses are required and the cache locality of those memory accesses.</p> <p>The PAGE_WALKS event can be used to count page walk durations with EDGE trigger bit cleared. Page walk duration divided by number of page walks is the average duration of page-walks.</p> <p>In the Goldmont microarchitecture, the number of page walks can be determined by using the events MEM_UOPS_RETIREDDTLB_MISS and ITLB.MISS.</p> <p>In the Silvermont microarchitecture, the combined number of page walks for data and instruction can be counted with PAGE_WALKS.WALKS.</p>	Silvermont, Airmont, Goldmont

Table B-1. Performance Monitoring Taxonomy

Name	Description	Applicable Microarchitectures
RAT	<p>The allocation pipeline moves uops from the Frontend to the back end. At the end of the allocated pipe, a uop must be written into one of 6 reservation stations (the RS). Each RS holds uops to be sent to a specific execution (or memory) cluster. Each RS has a finite capacity and may accumulate uops when it cannot send a uop to its execution cluster. Typical reasons an RS may fill include, but are not limited to, the execution of long latency uops like divide, the inability to schedule uops due to dependencies, or too many outstanding memory references. When the RS becomes full, it cannot accept more uops, and it will stall the allocation pipeline. The RS_FULL_STALL.ANY event will be asserted on any cycle when the allocation is stalled for any RSs being full and not for other reasons. (i.e., the allocated pipeline might be stalled for some other reason, but if RS is not full, the RS_FULL_STALL.ANY will not count). The MEC sub-event allows discovery of whether the MEC RS being full prevents further allocation.</p>	Silvermont, Airmont, Goldmont
REHABQ	<p>An internal queue holds memory reference micro-ops that cannot complete for one reason or another. The micro-ops remain in the REHABQ until they can be re-issued and completed.</p> <p>Examples of bottlenecks that cause micro-ops to go into REHABQ include, but are not limited to: cache line splits, blocked store forward and data not ready. Many other conditions that might cause a load or store to be sent to the REHABQ. For instance, if an older store has an unknown address, all subsequent stores must be sent to the REHABQ until that older store's address becomes known.</p>	Silvermont, Airmont
LOAD_BLOCKS	<p>Loads can be blocked for multiple reasons, including UTLB misses, blocked store forwards, 4-K aliases or other conditions. When a load needs data (in whole or part) that a previous store produced, a forward progress of the machine will face two scenarios. The first, wherein the machine waits until the previous store is complete (forwarding restricted, loads blocked). In the second, data can be forwarded to the load before the previous store is complete. The restricted situations are described next.</p> <p>When a load is checked against previous stores, not all of its address bits are compared to the store addresses. This can cause a load to be blocked because its address is similar (LD_BLOCKS.4K_ALIAS) to a pending store, even though technically the load does not need to be blocked). When conditions do not allow the load to receive data from the in-progress store, then the load is blocked until the pending store operation is complete. LD_BLOCKS.STORE_FORWARD counts times when a load was prohibited from receiving forwarded data from the store because of address mismatch (explained below). LD_BLOCKS.DATA_UNKNOWN counts when a load is blocked from using a store forward because the store data was not available at the right time. A load block will not be counted as both LD_BLOCKS.DATA_UNKNOWN and LD_BLOCK.STORE_FORWARD. The conditions under which a load can receive data from an older store are shown in Table F-17.</p> <p>These are precise events and thus will not count speculative loads that do not retire.</p>	Goldmont

Table B-1. Performance Monitoring Taxonomy

Name	Description	Applicable Microarchitectures
Uops Retired	<p>The processor decodes complex macro instructions into a sequence of simpler micro-ops. Most instructions are composed of one or two micro-ops. Some instructions are decoded into longer sequences of uops; for example, floating point transcendental instructions, assists, and rep string instructions.</p> <p>In some cases, micro-op sequences are fused, or whole instructions are fused, into one micro-op. A sub-event within UOPS_RETIREED is available for differentiating MSROM micro-ops on Goldmont. The available sub-events differ from other microarchitectures.</p>	Silvermont, Airmont, Goldmont
HW_INTERRUPTS	<p>These Events provide information regarding Hardware (Vectored, Fixed) interrupts. HW_INTERRUPTS.RECEIVED provides a count of the total number of Hardware Interrupts received by the processor. This event is a straightforward count of the number of interrupts the ROB recognizes. HW_INTERRUPTS.PENDING_AND_MASKED counts the number of core cycles that an interrupt is pending but cannot be delivered due to EFLAGS.IF being 0. It will not count interrupts that TPR or ISR mask. These events are not precise, but collecting non-precise PEBS records on these events can help identify issues causing an unresponsive system.</p>	Goldmont
MEM_UOPS_RETIREED	<p>These events count when a uop reads (loads) or writes (stores) data if that uop retired valid. Speculative loads and stores are not counted. The sub-events can indicate conditions that generally require extra cycles to complete the operation: specifically, if the address of memory uop misses in the Data Translation Lookaside Buffer (DTLB), the data requested spans a cache line (split), or the memory uop is a locked load: these are precise events, so the EventingRIP field in the PEBS record indicates the instruction which caused the event.</p>	Silvermont, Airmont, Goldmont
MEM_LOAD_UOPS_RETIREED	<p>These events count when an instruction produces a uop that reads (loads) data if that uop is retired valid. Speculative loads are not counted. These events report the various states of the memory hierarchy for the requested data, which helps determine the source of latency stalls in accessing data. These are precise events, so the EventingRIP field in the PEBS record indicates the instruction which caused the event.</p>	Goldmont

B.3 INTEL® XEON® PROCESSOR 5500 SERIES

Intel Xeon processor 5500 series are based on the same microarchitecture as Intel Core i7 processors; see Section 2.7, “Intel® Hyper-Threading Technology”. In addition, the Intel Xeon processor 5500 series support non-uniform memory access (NUMA) in platforms with two physical processors; see Figure B-4. Figure B-4 illustrates four-processor cores and an uncore sub-system in each physical processor. The uncore sub-system consists of L3, an integrated memory controller (IMC), and Intel QuickPath Interconnect (QPI) interfaces. The memory sub-system consists of three channels of DDR3 memory locally connected to each IMC. Access to physical memory connected to a non-local IMC is often described as a remote memory access.

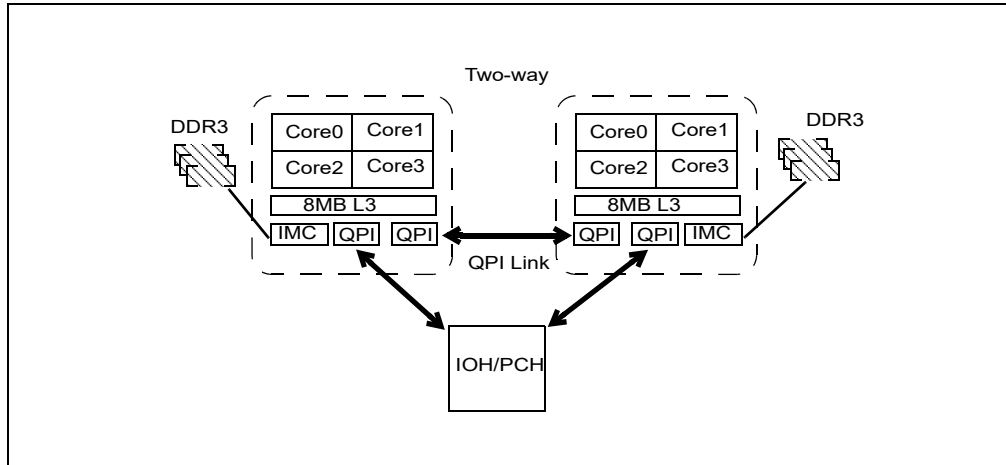

Figure B-4. System Topology Supported by Intel® Xeon® Processor 5500 Series

The performance monitoring events on Intel Xeon processor 5500 series can be used to analyze the interaction between software (code and data) and microarchitectural units hierarchically:

- **Per-core PMU:** Each processor core provides four programmable counters and three fixed counters. The programmable per-core counters can be configured to investigate **Frontend**/micro-op flow issues and stalls inside a processor core. Additionally, a subset of per-core PMU events supports precise event-based sampling (PEBS). Load latency measurement facility is new in Intel Core i7 processor and Intel Xeon processor 5500.
- **Uncore PMU:** The uncore PMU provides eight programmable counters and one fixed counter. The programmable per-core counters can be configured to characterize L3 and Intel QPI operations and local and remote data memory accesses.

The number and variety of performance counters and the breadth of programmable performance events available in Intel Xeon processor 5500 offer software tuning engineers the ability to analyze performance issues and achieve higher performance. Using performance events to analyze performance issues can be grouped into the following subjects:

- Cycle Accounting and Uop Flow
- Stall Decomposition and Core Memory Access Events (non-PEBS)
- Precise Memory Access Events (PEBS)
- Precise Branch Events (PEBS, LBR)
- Core Memory Access Events (non-PEBS)
- Other Core Events (non-PEBS)
- **Frontend** Issues
- Uncore Events

B.4 PERFORMANCE ANALYSIS TECHNIQUES FOR INTEL® XEON® PROCESSOR 5500 SERIES

The techniques covered in this chapter focus on identifying an opportunity to remove/reduce performance bottlenecks that are measurable at runtime. Compile-time and source-code level techniques are covered in other chapters in this document. Individual sub-sections describe specific methods to identify tuning opportunities by examining various metrics that can be measured or derived directly from performance monitoring events.

B.4.1 Cycle Accounting and Uop Flow Analysis

The objectives, performance metrics and component events of the basic cycle accounting technique are summarized in Table B-2.

Table B-2. Cycle Accounting and Micro-ops Flow Recipe

Summary	
Objective	Identify code/basic block that had significant stalls
Method	Binary decomposition of cycles into “productive“ and “unproductive“ parts
PMU-Pipeline Focus	Micro-ops issued to execute
Event code/Umask	Event code B1H, Umask= 3FH for micro-op execution; Event code 3CH, Umak= 1, CMask=2 for counting total cycles
EvtSelc	Use CMask, Invert, Edge fields to count cycles and separate stalled vs. active cycles
Basic Equation	“Total Cycles“ = UOPS_EXECUTED.CORE_STALLS_CYCLES + UOPS_EXECUTED.CORE_ACTIVE_CYCLES
Metric	UOPS_EXECUTED.CORE_STALLS_CYCLES / UOPS_EXECUTED.CORE_STALLS_COUNT
Drill-down scope	Counting: Workload; Sampling: basic block
Variations	Port 0,1, 5 cycle counting for computational micro-ops execution.

Cycle accounting of executed micro-ops is an effective technique to identify stalled cycles for performance tuning. Within the microarchitecture pipeline, the meaning of micro-ops being “issued,” “dispatched,” “executed,” “retired” has a precise definition. This is illustrated in Figure B-5.

Cycles are divided into those where micro-ops are dispatched to the execution units and those where no micro-ops are dispatched, which are considered execution stalls.

“Total cycles” of execution for the code under test can be directly measured with CPU_CLK_UNHALTED.THREAD (event code 3CH, Umask= 1) and setting CMask = 2 and INV=1 in IA32_PERFEVTSELN.

The signals used to count the memory access uops executed (ports 2, 3 and 4) are the only core events that cannot be counted per-logical processor. Thus, Event code B1H with Umask=3FH only counts on a per-core basis, and the entire execution stall cycles can only be evaluated on a per-core basis. If HT is disabled, conducting a per-thread analysis of micro-op flow cycle accounting presents no difficulty.

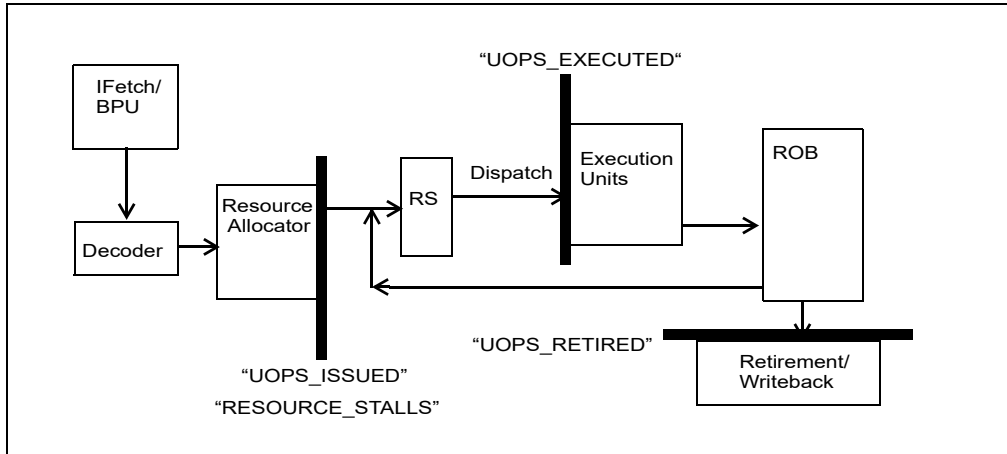

Figure B-5. PMU Specific Event Logic Within the Pipeline

The PMU signals to count uops_executed in ports 0, 1, 5 can count on a per-thread basis even when HT is active. This provides an alternate cycle accounting technique when the workload under test interacts with HT.

The alternate metric is built from UOPS_EXECUTED.PORT015_STALL_CYCLES, using appropriate CMask, Inv, and Edge settings. Details of performance events are shown in Table B-3.

Table B-3. CMask/Inv/Edge/Thread Granularity of Events for Micro-op Flow

Event Name	Umask	Event Code	CMask	Inv	Edge	All Thread
CPU_CLK_UNHALTED.TOTAL_CYCLES	0H	3CH	2	1	0	0
UOPS_EXECUTED.CORE_STALLS_CYCLES	3FH	B1H	1	1	0	1
UOPS_EXECUTED.CORE_STALLS_COUNT	3FH	B1H	1	1	!	1
UOPS_EXECUTED.CORE_ACTIVE_CYCLES	3FH	B1H	1	0	0	1
UOPS_EXECUTED.PORT015_STALL_CYCLES	40H	B1H	1	1	0	0
UOPS_RETIRED.STALL_CYCLES	1H	C2H	1	1	0	0
UOPS_RETIRED.ACTIVE_CYCLES	1H	C2H	1	0	0	0

B.4.1.1 Cycle Drill Down and Branch Mispredictions

While executed micro-ops are considered productive from the perspective of execution units being subscribed, not all such micro-ops contribute to forward progress of the program. Branch mispredictions can introduce execution inefficiencies in OOO processor that are typically decomposed into three components:

- Wasted work associated with executing the uops of the incorrectly predicted path.
- Cycles lost when the pipeline is flushed of the incorrect uops.

- Cycles lost while waiting for the correct uops to arrive at the execution units.

In processors based on Nehalem microarchitecture, there are no execution stalls associated with clearing the pipeline of mispredicted uops (component 2). These uops are simply removed from the pipeline without stalling executions or dispatch. This typically lowers the penalty for mispredicted branches. Further, the penalty associated with instruction starvation (component 3) can be measured.

The wasted work within executed uops are those uops that will never be retired. This is part of the cost associated with mispredicted branches. It can be found through monitoring the flow of uops through the pipeline. The uop flow can be measured at 3 points in Figure B-5, going into the RS with the event UOPS_ISSUED, going into the execution units with UOPS_EXECUTED and at retirement with UOPS_RETIRED. The differences of between the upstream measurements and at retirement measure the wasted work associated with these mispredicted uops.

As UOPS_EXECUTED must be measured per core, rather than per thread, the wasted work per core is evaluated as:

$$\text{Wasted Work} = \text{UOPS_EXECUTED.PORT234_CORE} + \text{UOPS_EXECUTED.PORT015_All_Thread} - \text{UOPS_RETIRED.ANY_ALL_THREAD}$$

The ratio above can be converted to cycles by dividing the average issue rate of uops. The events above were designed to be used in this manner without corrections for micro fusion or macro fusion.

A “per thread” measurement can be made from the difference between the uops issued and uops retired as the latter two of the above events can be counted per thread. It over counts slightly, by the mispredicted uops that are eliminated in the RS before they can waste cycles being executed, but this is usually a small correction:

$$\text{Wasted Work/thread} = (\text{UOPS_ISSUED.ANY} + \text{UOPS_ISSUED.FUSED}) - \text{UOPS_RETIRED.ANY}$$

Table B-4. Cycle Accounting of Wasted Work Due to Misprediction

Summary	
Objective	Evaluate uops that executed but not retired due to misprediction
Method	Examine uop flow differences between execution and retirement
PMU-Pipeline Focus	Micro-ops execute and retirement
Event code/Umask	Event code B1H, Umask= 3FH for micro-op execution; Event code C2H, Umask= 1, AllThread=1 for per-core counting
EvtSelc	Zero CMask, Invert, Edge fields to count uops
Basic Equation	“Wasted work” = UOPS_EXECUTED.PORT234_CORE + UOPS_EXECUTED.PORT015_ALL_THREAD - UOPS_RETIRED.ANY_ALL_THREAD
Drill-down scope	Counting: Branch misprediction cost
Variations	Divide by average uop issue rate for cycle accounting. Set AllThread=0 to estimate per-thread cost.

The third component of the misprediction penalty, instruction starvation, occurs when the instructions associated with the correct path are far away from the core and execution is stalled due to lack of uops in the RAT. Because the two primary cause of uops not being issued are either Frontend starvation or resource not available in the back end. So the output of the resource allocation can be measured as follows:

- Count the total number of cycles where no uops were issued to the OOO engine.

- Count the cycles where resources (RS, ROB entries, load buffer, store buffer, etc.) are not available for allocation.

If HT is not active, instruction starvation is simply the difference:

$$\text{Instruction Starvation} = \text{UOPS_ISSUED.STALL_CYCLES} - \text{RESOURCE_STALLS.ANY.}$$

When HT is enabled, the uop delivery to the RS alternates between the two threads. In an ideal case the above condition would then over count, as 50% of the issuing stall cycles may be delivering uops for the other thread. The expression can be modified by subtracting the cycles that the other thread is having uops issued.

$$\text{Instruction Starvation (per thread)} = \text{UOPS_ISSUED.STALL_CYCLES} - \text{RESOURCE_STALLS.ANY} - \text{UOPS_ISSUED.ACTIVE_CYCLES_OTHER_THREAD.}$$

The per-thread expression above will over count somewhat because the resource_stall condition could exist on "this" thread while the other thread in the same core was issuing uops. An alternative might be:

$$\text{CPU_CLK_UNHALTED.THREAD} - \text{UOPS_ISSUED.CORE_CYCLES_ACTIVE} - \text{RESOURCE_STALLS.ANY.}$$

The above technique is summarized in Table B-5.

Table B-5. Cycle Accounting of Instruction Starvation

Summary	
Objective	Evaluate cycles that uops issuing is starved after misprediction
Method	Examine cycle differences between uops issuing and resource allocation
PMU-Pipeline Focus	Micro-ops issue and resource allocation
Event code/Umask	Event code 0EH, Umask= 1, for uops issued. Event code A2H, Umask=1, for Resource allocation stall cycles
EvtSelc	Set CMask=1, Inv=1, fields to count uops issue stall cycles. Set CMask=1, Inv=0, fields to count uops issue active cycles. Use AllThread = 0 and AllThread=1 on two counter to evaluate contribution from the other thread for UOPS_ISSUED.ACTIVE_CYCLES_OTHER_THREAD
Basic Equation	"Instruction Starvation" (HT off) = UOPS_ISSUED.STALL_CYCLES - RESOURCE_STALLS.ANY;
Drill-down scope	Counting: Branch misprediction cost
Variations	Evaluate per-thread contribution with Instruction Starvation = UOPS_ISSUED.STALL_CYCLES - RESOURCE_STALLS.ANY - UOPS_ISSUED.ACTIVE_CYCLES_OTHER_THREAD

Details of performance events are shown in Table B-6.

Table B-6. CMask/Inv/Edge/Thread Granularity of Events for Micro-op Flow

Event Name	Umask	Event Code	CMask	Inv	Edge	All Thread
UOPS_EXECUTED.PORT234_CORE	80H	B1H	0	0	0	1
UOPS_EXECUTED.PORT015_ALL_THR EAD	40H	B1H	0	0	0	1
UOPS_RETIRED.ANY_ALL_THREAD	1H	C2H	0	0	0	1
RESOURCE_STALLS.ANY	1H	A2H	0	0	0	0
UOPS_ISSUED.ANY	1H	0EH	0	0	0	0
UOPS_ISSUED.STALL_CYCLES	1H	0EH	1	1	0	0
UOPS_ISSUED.ACTIVE_CYCLES	1H	0EH	1	0	0	0
UOPS_ISSUED.CORE_CYCLES_ACTIVE	1H	0EH	1	0	0	1

B.4.1.2 Basic Block Drill Down

The event INST_RETIRED.ANY (instructions retired) is commonly used to evaluate a cycles/instruction ratio (CPI). Another important usage is to determine the performance-critical basic blocks by evaluating basic block execution counts.

In a sampling tool (such as VTune Analyzer), the samples tend to cluster around certain IP values. This is true when using INST_RETIRED.ANY or cycle counting events. Disassembly listing based on the hot samples may associate some instructions with high sample counts and adjacent instructions with no samples.

Because all instructions within a basic block are retired exactly the same number of times by the very definition of a basic block. Drilling down the hot basic blocks will be more accurate by averaging the sample counts over the instructions of the basic block.

$$\text{Basic Block Execution Count} = \text{Sum (Sample counts of instructions within basic block)} * \text{Sample_after_value} / (\text{number of instructions in basic block})$$

Inspection of disassembly listing to identify basic blocks associated with loop structure being a hot loop or not can be done systematically by adapting the technique above to evaluate the trip count of each loop construct. For a simple loop with no conditional branches, the trip count ends up being the ratio of the basic block execution count of the loop block to the basic block execution count of the block immediately before and/or after the loop block. Judicious use of averaging over multiple blocks can be used to improve the accuracy.

This will allow the user to identify loops with high trip counts to focus on tuning efforts. This technique can be implemented using fixed counters.

Chains of dependent long-latency instructions (fmul, fadd, imul, etc) can result in the dispatch being stalled while the outputs of the long latency instructions become available. In general there are no events that assist in counting such stalls with the exception of instructions using the divide/sqrt execution unit. In such cases, the event ARITH can be used to count both the occurrences of these instructions and the duration in cycles that they kept their execution units occupied. The event ARITH.CYCLES_DIV_BUSY counts the cycles that either the divide/sqrt execution unit was occupied.

B.4.2 Stall Cycle Decomposition and Core Memory Accesses

The decomposition of the stall cycles is accomplished through a standard approximation. It is assumed that the penalties occur sequentially for each performance impacting event. Consequently, the total loss of cycles available for useful work is then the number of events, N_i , times the average penalty for each type of event, P_i

$$\text{Counted_Stall_Cycles} = \text{Sum} (N_i * P_i)$$

This only accounts for the performance impacting events that are or can be counted with a PMU event. Ultimately there will be several sources of stalls that cannot be counted, however their total contribution can be estimated:

$$\text{Unaccounted stall cycles} = \text{Stall_Cycles} - \text{Counted_Stall_Cycles} = \text{UOPS_EXECUTED.CORE_STALLS_CYCLES} - \text{Sum} (N_i * P_i)_{\text{both_threads}}$$

The unaccounted component can become negative as the sequential penalty model is overly simple and usually over counts the contributions of the individual microarchitectural issues.

As noted in Section B.4.1.1, UOPS_EXECUTED.CORE_STALL_CYCLES counts on a per core basis rather than on a per thread basis, the over counting can become severe. In such cases it may be preferable to use the port 0,1,5 uop stalls, as that can be done on a per thread basis:

$$\text{Unaccounted stall cycles (per thread)} = \text{UOPS_EXECUTED.PORT015_THREADED_STALLS_CYCLES} - \text{Sum} (N_i * P_i)$$

This unaccounted component is meant to represent the components that were either not counted due to lack of performance events or simply neglected during the data collection.

One can also choose to use the "retirement" point as the basis for stalls. The PEBS event, UOPS_RETIRED.STALL_CYCLES, has the advantage of being evaluated on a per thread basis and being having the HW capture the IP associated with the retiring uop. This means that the IP distribution will not be effected by STI/CLI deferral of interrupts in critical sections of OS kernels, thus producing a more accurate profile of OS activity.

B.4.2.1 Measuring Costs of Microarchitectural Conditions

Decomposition of stalled cycles in this manner should start by first focusing on conditions that carry large performance penalty, for example, events with penalties of greater than 10 cycles. Short penalty events ($P < 5$ cycles) can frequently be hidden by the combined actions of the OOO execution and the compiler. The OOO engine manages both types of situations in the instruction stream and strive to keep the execution units busy during stalls of either type due to instruction dependencies. Usually, the large penalty operations are dominated by memory access and the very long latency instructions for divide and sqrt.

The largest penalty events are associated with load operations that require a cacheline which is not in L1 or L2 of the cache hierarchy. **Occurrences must be counted, and the penalty to be assigned must be known.**

The standard approach to measuring latency is to measure the average number of cycles a request is in a queue:

$$\text{Latency} = \text{Sum} (\text{CYCLES_Queue_entries_outstanding}) / \text{Queue_inserts}$$

where "queue_inserts" refers to the total number of entries that caused the outstanding cycles in that queue. However, the penalty associated with each queue insert (i.e. cachemiss), is the latency divided by the average queue occupancy. This correction is needed to avoid over counting associated with overlapping penalties.

$$\text{Avg_Queue_Depth} = \text{Sum} (\text{CYCLES_Queue_entries_outstanding}) / \text{Cycles_Queue_not_empty}$$

The the penalty (cost) of each occurrence is

$$\text{Penalty} = \text{Latency} / \text{Avg_Queue_Depth} = \text{Cycles_Queue_not_empty} / \text{Queue_inserts}$$

An alternative way of thinking about this is to realize that the sum of all the penalties, for an event that occupies a queue for its duration, cannot exceed the time that the queue is not empty

$$\text{Cycles_Queue_not_empty} = \text{Events} * \langle \text{Penalty} \rangle$$

The standard techniques described above are simple conceptually. In practice, the large amount of memory references in the workload and wide range of varying state/location-specific latencies made standard sampling techniques less practical. Using precise-event-based sampling (PEBS) is the preferred technique for processors based on Nehalem microarchitecture.

The profiling the penalty by sampling (to localize the measurement in IP) is likely to have accuracy difficulties. Since the latencies for L2 misses can vary from 40 to 400 cycles, collecting the number of required samples will tend to be invasive.

The use of the precise latency event, that will be discussed later, provides a more accurate and flexible measurement technique when sampling is used. As each sample records both a load to use latency and a data source, the average latency per data source can be evaluated. Further as the PEBS hardware supports buffering the events without generating a PMI until the buffer is full, it is possible to make such an evaluation efficient without perturbing the workload intrusively.

A number of performance events in core PMU can be used to measure the costs of memory accesses that originated in the core and experienced delays due to various conditions, locality, or traffic due to cache coherence requirements. The latency of memory accesses vary, depending on locality of L3, DRAM attached to the local memory controller or remote controller, and cache coherency factors. Some examples of the approximate latency values are shown in Table B-7.

Table B-7. Approximate Latency of L2 Misses of Intel Xeon Processor 5500

Data Source	Latency
L3 hit, Line exclusive	~ 42 cycles
L3 Hit, Line shared	~ 63 cycles
L3 Hit, modified in another core	~ 73 cycles
Remote L3	100 - 150 cycles
Local DRAM	~ 50 ns
Remote DRAM	~ 90 ns

B.4.3 Core PMU Precise Events

The Precise Event Based Sampling (PEBS) mechanism enables the PMU to capture the architectural state and IP at the completion of the instruction that caused the event. This provides two significant benefit for profiling and tuning:

- The location of the eventing condition in the instruction space can be accurate profiled,
- Instruction arguments can be reconstructed in a post processing phase, using captured PEBS records of the register states.

The PEBS capability has been greatly expanded in processors based on Nehalem microarchitecture, covering a large number of and more types of precise events.

The mechanism works by using the counter overflow to arm the PEBS data acquisition. Then on the next event, the data is captured and the interrupt is raised.

The captured IP value is sometimes referred to as IP +1, because at the completion of the instruction, the IP value is that of the next instruction.

By their very nature precise events must be “at-retirement” events. For the purposes of this discussion the precise events are divided into Memory Access events, associated with the retirement of loads and stores, and Execution Events, associated with the retirement of all instructions or specific non memory instructions (branches, FP assists, SSE uops).

B.4.3.1 Precise Memory Access Events

There are two important common properties to all precise memory access events:

- The exact instruction can be identified because the hardware captures the IP of the offending instruction. Of course the captured IP is that of the following instruction but one simply moves the samples up one instruction. This works even when the recorded IP points to the first instruction of a basic block because in such a case the offending instruction has to be the last instruction of the previous basic block, as branch instructions never load or store data, instruction arguments can be reconstructed in a post processing phase, using captured PEBS records of the register states.
- The PEBS buffer contains the values of all 16 general registers, R1-R16, where R1 is also called RAX. When coupled with the disassembly the address of the load or store can be reconstructed and used for data access profiling. The Intel® Performance Tuning Utility does exactly this, providing a wide variety of powerful analysis techniques

Precise memory access events mainly focus on loads as those are the events typically responsible for the very long duration execution stalls. They are broken down by the data source, thereby indicating the typical latency and the data locality in the intrinsically NUMA configurations. These precise load events are the only L2, L3 and DRAM access events that only count loads. All others will also include the L1D and/or L2 hardware prefetch requests. Many will also include RFO requests, both due to stores and to the hardware prefetchers.

All four general counters can be programmed to collect data for precise events. The ability to reconstruct the virtual addresses of the load and store instructions allows an analysis of the cacheline and page usage efficiency. Even though cachelines and pages are defined by physical address the lower order bits are identical, so the virtual address can be used.

As the PEBS mechanism captures the values of the register at completion of the instruction, one should be aware that pointer-chasing type of load operation will not be captured because it is not possible to infer the load instruction from the dereferenced address.

The basic PEBS memory access events falls into the following categories:

- **MEM_INST_RETIRED**: This category counts instruction retired which contain a load operation, it is selected by event code 0BH.
- **MEM_LOAD_RETIRED**: This category counts retired load instructions that experienced specific condition selected by the Umask value, the event code is 0CBH.
- **MEM_UNCORE_RETIRED**: This category counts memory instructions retired and received data from the uncore sub-system, it is selected by event code 0FH.
- **MEM_STORE_RETIRED**: This category counts instruction retired which contain a store operation, it is selected by event code 0CH.
- **ITLB_MISS_RETIRED**: This counts instruction retired which missed the ITLB, it is selected by event code 0C8H

Umask values and associated name suffixes for the above PEBS memory events are listed at:

<https://perfmon-events.intel.com/>.

The precise events listed above allow load driven cache misses to be identified by data source. This does not identify the "home" location of the cachelines with respect to the NUMA configuration. The exceptions to this statement are the events

MEM_UNCORE_RETIRED.LOCAL_DRAM and **MEM_UNCORE_RETIRED.NON_LOCAL_DRAM**. These can be used in conjunction with instrumented malloc invocations to identify the NUMA "home" for the critical contiguous buffers used in an application.

The sum of all the **MEM_LOAD_RETIRED** events will equal the **MEM_INST_RETIRED.LOADS** count.

A count of L1D misses can be achieved with the use of all the **MEM_LOAD_RETIRED**

events, except **MEM_LOAD_RETIRED.L1D_HIT**. It is better to use all of the individual **MEM_LOAD_RETIRED** events to do this, rather than the difference of **MEM_INST_RETIRED.LOADS-MEM_LOAD_RETIRED.L1D_HIT** because while the total counts of precise events will be correct, and they will correctly identify instructions that caused the event in question, the distribution of the events may not be correct due to PEBS SHADOWING, discussed later in this section.

`L1D_MISSES = MEM_LOAD_RETIRED.HIT_LFB + MEM_LOAD_RETIRED.L2_HIT + MEM_LOAD_RETIRED.L3_UNSHARED_HIT + MEM_LOAD_RETIRED.OTHER_CORE_HIT_HITM + MEM_LOAD_RETIRED.L3_MISS`

The `MEM_LOAD_RETIRED.L3_UNSHARED_HIT` event merits some explanation. The inclusive L3 has a bit pattern to identify which core has a copy of the line. If the only bit set is for the requesting core (unshared hit) then the line can be returned from the L3 with no snooping of the other cores. If multiple bits are set, then the line is in a shared state and the copy in the L3 is current and can also be returned without snooping the other cores.

If the line is read for ownership (RFO) by another core, this will put the copy in the L3 into an exclusive state. If the line is then modified by that core and later evicted, the written back copy in the L3 will be in a modified state and snooping will not be required. `MEM_LOAD_RETIRED.L3_UNSHARED_HIT` counts all of these. The event should really have been called `MEM_LOAD_RETIRED.L3_HIT_NO_SNOOP`.

The event `MEM_LOAD_RETIRED.L3_HIT_OTHER_CORE_HIT_HITM` could have been named as `MEM_LOAD_RETIRED.L3_HIT_SNOOP` intuitively for similar reason.

When a modified line is retrieved from another socket it is also written back to memory. This causes remote HITM access to appear as coming from the home dram. The `MEM_UNCORE_RETIRED.LOCAL_DRAM` and `MEM_UNCORE_RETIRED.REMOTE_DRAM` events thus also count the L3 misses satisfied by modified lines in the caches of the remote socket.

There is a difference in the behavior of `MEM_LOAD_RETIRED.DTLB_MISSES` with respect to that on Intel® Core™2 processors. Previously the event only counted the first miss to the page, as do the imprecise events. The event now counts all loads that result in a miss, thus it includes the secondary misses as well.

B.4.3.2 Load Latency Event

Intel processors based on Nehalem microarchitecture provide support for “load-latency event”, `MEM_INST_RETIRED` with event code 0BH and Umask value of 10H (`LATENCY_ABOVE_THRESHOLD`). This event samples loads, recording the number of cycles between the execution of the instruction and actual deliver of the data. If the measured latency is larger than the minimum latency programmed into MSR 0x3f6, bits 15:0, then the counter is incremented.

Counter overflow arms the PEBS mechanism and on the next event satisfying the latency threshold, the PMU writes the measured latency, the virtual or linear address, and the data source into a PEBS record format in the PEBS buffer. Because the virtual address is captured into a known location, the sampling driver could also execute a virtual to physical translation and capture the physical address. The physical address identifies the NUMA home location and in principle allows an analysis of the details of the cache occupancies.

Further, as the address is captured before retirement even the pointer chasing encoding “`MOV RAX, [RAX+const]`” have their addresses captured. Because the `MSR_PEBS_LD_LAT_THRESHOLD` MSR is required to specify the latency threshold value, only one minimum latency value can be sampled on a core during a given period. To enable this, the Intel performance tools restrict the programming of this event to counter 4 to simplify the scheduling. Table B-8 lists a few examples of event programming configurations used by the Intel® PTU and Vtune™ Performance Analyzer for the load latency events. Different threshold values for the minimum latencies are specified in `MSR_PEBS_LD_LAT_THRESHOLD` (address 0x3f6).

Table B-8. Load Latency Event Programming

Load Latency Precise Events	MSR 0x3F6	Umask	Event Code
MEM_INST_RETIRED.LATENCY_ABOVE_THRESHOLD_4	4	10H	0BH
MEM_INST_RETIRED.LATENCY_ABOVE_THRESHOLD_8	8	10H	0BH
MEM_INST_RETIRED.LATENCY_ABOVE_THRESHOLD_10	16	10H	0BH
MEM_INST_RETIRED.LATENCY_ABOVE_THRESHOLD_20	32	10H	0BH
MEM_INST_RETIRED.LATENCY_ABOVE_THRESHOLD_40	64	10H	0BH
MEM_INST_RETIRED.LATENCY_ABOVE_THRESHOLD_80	128	10H	0BH
MEM_INST_RETIRED.LATENCY_ABOVE_THRESHOLD_100	256	10H	0BH
MEM_INST_RETIRED.LATENCY_ABOVE_THRESHOLD_200	512	10H	0BH
MEM_INST_RETIRED.LATENCY_ABOVE_THRESHOLD_8000	32768	10H	0BH

One of the three fields written to each PEBS record by the PEBS assist mechanism of the load latency event, encodes the data source locality information.

Table B-9. Data Source Encoding for Load Latency PEBS Record

Encoding	Description
0x0	Unknown L3 cache miss.
0x1	Minimal latency core cache hit. This request was satisfied by the L1 data cache.
0x2	Pending core cache HIT. Outstanding core cache miss to same cache-line address was already underway. The data is not yet in the data cache, but is located in a fill buffer that will soon be committed to cache.
0x3	This data request was satisfied by the L2.
0x4	L3 HIT. Local or Remote home requests that hit L3 cache in the uncore with no coherency actions required (snooping).
0x5	L3 HIT (other core hit snoop). Local or Remote home requests that hit the L3 cache and was serviced by another processor core with a cross core snoop where no modified copies were found. (Clean).
0x6	L3 HIT (other core HITM). Local or Remote home requests that hit the L3 cache and was serviced by another processor core with a cross core snoop where modified copies were found. (HITM).
0x7	Reserved
0x8	L3 MISS (remote cache forwarding). Local homed requests that missed the L3 cache and was serviced by forwarded data following a cross package snoop where no modified copies found. (Remote home requests are not counted).
0x9	Reserved.
0xA	L3 MISS (local DRMA go to S). Local home requests that missed the L3 cache and was serviced by local DRAM (go to shared state).
0xB	L3 MISS (remote DRMA go to S). Remote home requests that missed the L3 cache and was serviced by remote DRAM (go to shared state).
0xC	L3 MISS (local DRMA go to E). Local home requests that missed the L3 cache and was serviced by local DRAM (go to exclusive state).

Table B-9. Data Source Encoding for Load Latency PEBS Record (Contd.)

Encoding	Description
0xD	L3 MISS (remote DRMA go to E). Remote home requests that missed the L3 cache and was serviced by remote DRAM (go to exclusive state).
0xE	I/O, Request of input/output operation.
0xF	The request was to uncacheable memory.

The latency event is the recommended method to measure the penalties for a cycle accounting decomposition. Each time a PMI is raised by this PEBS event a load to use latency and a data source for the cacheline is recorded in the PEBS buffer. The data source for the cacheline can be deduced from the low order 4 bits of the data source field and the table shown above. Thus an average latency for each of the 16 sources can be evaluated from the collected data. As only one minimum latency at a time can be collected it may be awkward to evaluate the latency for an MLC hit and a remote socket dram. A minimum latency of 32 cycles should give a reasonable distribution for all the off-core sources however. The Intel® PTU version 3.2 performance tool can display the latency distribution in the data profiling mode and allows sophisticated event filtering capabilities for this event.

B.4.3.3 Precise Execution Events

PEBS capability in core PMU goes beyond load and store instructions. Branches, near calls and conditional branches can all be counted with precise events, for both retired and mispredicted (and retired) branches of the type selected. For these events, the PEBS buffer will contain the target of the branch. If the Last Branch Record (LBR) is also captured then the location of the branch instruction can also be determined.

When the branch is taken the IP value in the PEBS buffer will also appear as the last target in the LBR. If the branch was not taken (conditional branches only) then it won't and the branch that was not taken and retired is the instruction before the IP in the PEBS buffer.

In the case of near calls retired, this means that Event Based Sampling (EBS) can be used to collect accurate function call counts. As this is the primary measurement for driving the decision to inline a function, this is an important improvement. In order to measure call counts, you must sample on calls. Any other trigger introduces a bias that cannot be guaranteed to be corrected properly.

The precise branch events can be found under event code C4H at: <https://perfmon-events.intel.com/>.

There is one source of sampling artifact associated with precise events. It is due to the time delay between the PMU counter overflow and the arming of the PEBS hardware. During this period events cannot be detected due to the timing shadow. To illustrate the effect, consider a function call chain where a long duration function, "foo", which calls a chain of 3 very short duration functions, "foo1" calling "foo2" which calls "foo3", followed by a long duration function "foo4". If the durations of foo1, foo2 and foo3 are less than the shadow period the distribution of PEBS sampled calls will be severely distorted. For example:

- If the overflow occurs on the call to foo, the PEBS mechanism is armed by the time the call to foo1 is executed and samples will be taken showing the call to foo1 from foo.
- If the overflow occurs due to the call to foo1, foo2 or foo3 however, the PEBS mechanism will not be armed until execution is in the body of foo4. Thus the calls to foo2, foo3 and foo4 cannot appear as PEBS sampled calls.

Shadowing can effect the distribution of all PEBS events. It will also effect the distribution of basic block execution counts identified by using the combination of a branch retired event (PEBS or not) and the last entry in the LBR. If there were no delay between the PMU counter overflow and the LBR freeze, the last LBR entry could be used to sample taken retired branches and from that the basic block execution counts. All the instructions between the last taken branch and the previous target are executed once.

Such a sampling could be used to generate a "software" instruction retired event with uniform sampling, which in turn can be used to identify basic block execution counts. Unfortunately the shadowing causes the branches at the end of short basic blocks to not be the last entry in the LBR, distorting the measurement. Since all the instructions in a basic block are by definition executed the same number of times.

The shadowing effect on call counts and basic block execution counts can be alleviated to a large degree by averaging over the entries in the LBR. This will be discussed in the section on LBRs.

Typically, branches account for more than 10% of all instructions in a workload, loop optimization must focus on those loops with high tripcounts. For counted loops, it is very common for the induction variable to be compared to the tripcount in the termination condition evaluation. This is particularly true if the induction variable is used within the body of the loop, even in the face of heavy optimization. Thus a loop sequence of unrolled operation by eight times may resemble:

```
add    rcx, 8
cmp    rcx, rax
jnge   triad+0x27
```

In this case the two registers, rax and rcx are the tripcount and induction variable. If the PEBS buffer is captured for the conditional branches retired event, the average values of the two registers in the compare can be evaluated. The one with the larger average will be the tripcount. Thus the average, RMS, min and max can be evaluated and even a distribution of the recorded values.

B.4.3.4 Last Branch Record (LBR)

The LBR captures the source and target of each retired taken branch. Processors based on Nehalem microarchitecture can track 16 pairs of source/target addresses in a rotating buffer. Filtering of the branch instructions by types and privilege levels are permitted using a dedicated facility, MSR_LBR_SELECT. This means that the LBR mechanism can be programmed to capture branches occurring at ring 0 or ring 3 or both (default) privilege levels. Further the types of taken branches that are recorded can also be filtered. The list of filtering options that can be specified using MSR_LBR_SELECT is described in Chapter 18, "Debug, Branch Profile, TSC, and Intel® Resource Director Technology (Intel® RDT) Features" of *Intel® 64 and IA-32 Architectures Software Developer's Manual, Volume 3B*.

The default is to capture all branches at all privilege levels (all bits zero). Another reasonable programming would set all bits to 1 except bit 1 (capture ring 3) and bit 3 (capture near calls) and bits 6 and 7. This would leave only ring 3 calls and unconditional jumps in the LBR. Such a programming would result in the LBR having the last 16 taken calls and unconditional jumps retired and their targets in the buffer.

A PMU sampling driver could then capture this restricted "call chain" with any event, thereby providing a "call tree" context. The inclusion of the unconditional jumps will unfortunately cause problems, particularly when there are if-else structures within loops.

In the case of frequent function calls at all levels, the inclusion of returns could be added to clarify the context. However this would reduce the call chain depth that could be captured. A fairly obvious usage would be to trigger the sampling on extremely long latency loads, to enrich the sample with accesses to heavily contended locked variables, and then capture the call chain to identify the context of the lock usage.

Call Counts and Function Arguments

If the LBRs are captured for PMIs triggered by the BR_INST_RETIRED.NEAR_CALL event, then the call count per calling function can be determined by simply using the last entry in LBR. As the PEBS IP will equal the last target IP in the LBR, it is the entry point of the calling function. Similarly, the last source in the LBR buffer was the call site from within the calling function. If the full PEBS record is captured as well, then for functions with limited numbers of arguments on 64-bit OS's, you can sample both the call counts and the function arguments.

LBRs and Basic Block Execution Counts

Another interesting usage is to use the BR_INST_RETIRED.ALL_BRANCHES event and the LBRs with no filter to evaluate the execution rate of basic blocks. As the LBRs capture all taken branches, all the basic blocks between a branch IP (source) and the previous target in the LBR buffer were executed one time. Thus a simple way to evaluate the basic block execution counts for a given load module is to make a map of the starting locations of every basic block. Then for each sample triggered by the PEBS collection of BR_INST_RETIRED.ALL_BRANCHES, starting from the PEBS address (a target but perhaps for a not taken branch and thus not necessarily in the LBR buffer) and walking backwards through the LBRs until

finding an address not corresponding to the load module of interest, count all the basic blocks that were executed. Calling this value "number_of_basic_blocks", increment the execution counts for all of those blocks by 1/(number_of_basic_blocks). This technique also yields the taken and not taken rates for the active branches. All branch instructions between a source IP and the previous target IP (within the same module) were not taken, while the branches listed in the LBR were taken. This is illustrated in the graphics below.

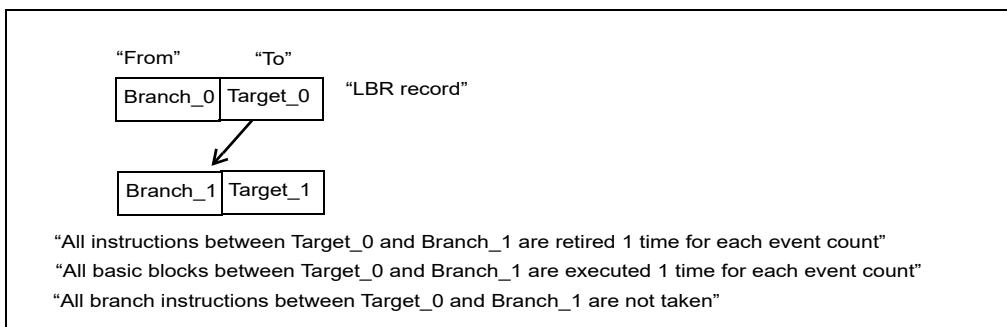

Figure B-6. LBR Records and Basic Blocks

The 16 sets LBR records can help rectify the artifact of PEBS samples aggregating disproportionately to certain instructions in the sampling process. The situation of skewed distribution of PEBS sample is illustrated below in Figure B-7.

Consider a number of basic blocks in the flow of normal execution, some basic block takes 20 cycles to execute, others taking 2 cycles, and shadowing takes 10 cycles. Each time an overflow condition occurs, the delay of PEBS being armed is at least 10 cycles. Once the PEBS is armed, PEBS record is captured on the next eventing condition. The skewed distribution of sampled instruction address using PEBS record will be skewed as shown in the middle of Figure B-7. In this conceptual example, every branch is assumed to be taken in these basic blocks.

In the skewed distribution of PEBS samples, the branch IP of the last basic block will be recorded 5 times as much as the least sampled branch IP address (the 2nd basic block).

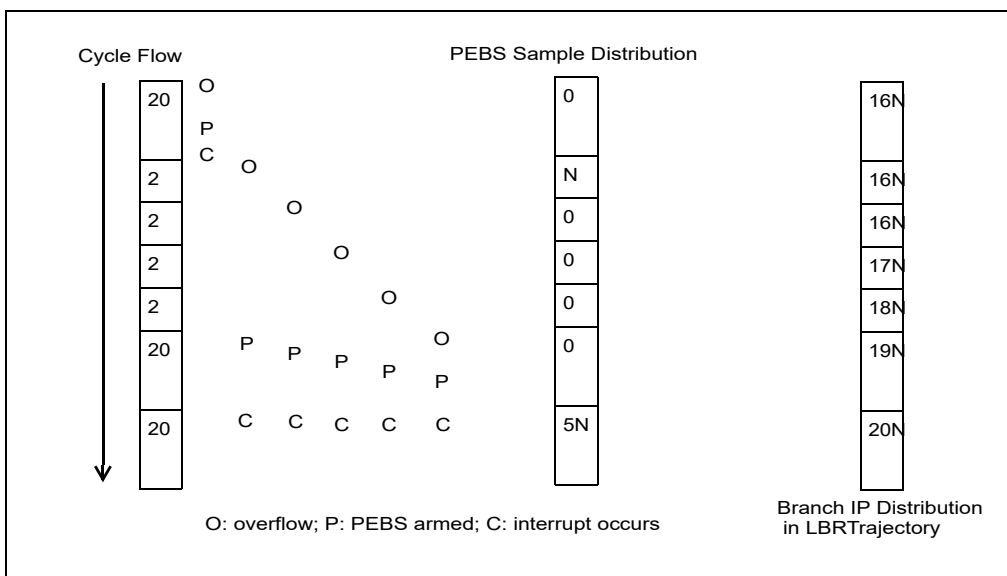

Figure B-7. Using LBR Records to Rectify Skewed Sample Distribution

This situation where some basic blocks would appear to never get samples and some have many times too many. Weighting each entry by $1/(\text{num of basic blocks in the LBR trajectory})$, in this example would result in dividing the numbers in the right most table by 16. Thus far more accurate execution counts are achieved $((1.25 \rightarrow 1.0) * N)$ in all of the basic blocks, even those that never directly caused a PEBS sample.

As on Intel® Core™2 processors there is a precise instructions retired event that can be used in a wide variety of ways. In addition there are precise events for uops_retired, various SSE instruction classes, FP assists. It should be noted that the FP assist events only detect x87 FP assists, not those involving SSE FP instructions. Detecting all assists will be discussed in the section on the pipeline Frontend.

The instructions retired event has a few special uses. While its distribution is not uniform, the totals are correct. If the values recorded for all the instructions in a basic block are averaged, a measure of the basic block execution count can be extracted. The ratios of basic block executions can be used to estimate loop tripcounts when the counted loop technique discussed above cannot be applied.

The PEBS version (general counter) instructions retired event can further be used to profile OS execution accurately even in the face of STI/CLI semantics, because the PEBS interrupt then occurs after the critical section has completed, but the data was frozen correctly. If the CMask value is set to some very high value and the invert condition is applied, the result is always true, and the event will count core cycles (halted + unhalted).

Consequently both cycles and instructions retired can be accurately profiled. The UOPS_RETIRED.ANY event, which is also precise can also be used to profile Ring 0 execution and really gives a more accurate display of execution. The precise events available for this purpose are listed under event code C0H, C2H, C7H, F7H at: <https://perfmon-events.intel.com/>.

Measuring Core Memory Access Latency

Drilling down performance issues associated with locality or cache coherence issues will require using performance monitoring events. In each processor core, there is a super queue that allocates entries to buffer requests of memory access traffic due to an L2 miss to the uncore sub-system. Table B-10 lists various performance events available in the core PMU that can drill down performance issues related to L2 misses.

Table B-10. Core PMU Events to Drill Down L2 Misses

Core PMU Events	Umask	Event Code
OFFCORE_REQUESTS.DEMAND.READ_DATA ¹	01H	B0H
OFFCORE_REQUESTS.DEMAND.READ_CODE ¹	02H	B0H
OFFCORE_REQUESTS.DEMAND.RFO ¹	04H	B0H
OFFCORE_REQUESTS.ANY.READ	08H	B0H
OFFCORE_REQUESTS.ANY.RFO	10H	B0H
OFFCORE_REQUESTS.UNCACHED_MEM	20H	B0H
OFFCORE_REQUESTS.L1D.WRITEBACK	40H	B0H
OFFCORE_REQUESTS.ANY	80H	B0H

NOTES:

1. The *DEMAND* events also include any requests made by the L1D cache hardware prefetchers.

Table B-11 lists various performance events available in the core PMU that can drill down performance issues related to super queue operation.

Table B-11. Core PMU Events for Super Queue Operation

Core PMU Events	Umask	Event Code
OFFCORE_REQUESTS_BUFFER_FULL	01H	B2H

Additionally, L2 misses can be drilled down further by data origin attributes and response attributes. The matrix to specify data origin and response type attributes is done by a dedicated MSR OFFCORE_RSP_0 at address 1A6H. See Table B-12 and Table B-13.

Table B-12. Core PMU Event to Drill Down OFFCore Responses

Core PMU Events	OFFCORE_RSP_0 MSR	Umask	Event Code
OFFCORE_RESPONSE	See Table B-13	01H	B7H

Table B-13. OFFCORE_RSP_0 MSR Programming

	Position	Description	Note
Request type	0	Demand Data Rd = DCU reads (includes partials, DCU Prefetch)	
	1	Demand RFO = DCU RFOs	
	2	Demand IFetch = IFU Fetches	
	3	Writeback = L2_EVICT/DCUWB	
	4	PF Data Rd = L2 Prefetcher Reads	
	5	PF RFO= L2 Prefetcher RFO	
	6	PF IFetch= L2 Prefetcher Instruction fetches	
	7	Other	Include non-temporal stores
	8	L3_HIT_UNCORE_HIT	exclusive line
	9	L3_HIT_OTHER_CORE_HIT_SNP	clean line
	10	L3_HIT_OTHER_CORE_HITM	modified line
	11	L3_MISS_REMOTE_HIT_SCRUB	Used by multiple cores
	12	L3_MISS_REMOTE_FWD	Clean line used by one core
	13	L3_MISS_REMOTE_DRAM	
	14	L3_MISS_LOCAL_DRAM	
15	Non-DRAM	Non-DRAM requests	

Although Table B-13 allows 2^{16} combinations of setting in MSR_OFFCORE_RSP_0 in theory, it is more useful to consider combining the subsets of 8-bit values to specify “Request type” and “Response type”. The more common 8-bit mask values are listed in Table B-14.

Table B-14. Common Request and Response Types for OFFCORE_RSP_0 MSR

Request Type	Mask	Response Type	Mask
ANY_DATA	xx11H	ANY_CACHE_DRAM	7FxxH
ANY_IFETCH	xx44H	ANY_DRAM	60xxH
ANY_REQUEST	xxFFH	ANY_L3_MISS	F8xxH
ANY_RFO	xx22H	ANY_LOCATION	FFxxH
CORE_WB	xx08H	IO	80xxH
DATA_IFETCH	xx77H	L3_HIT_NO_OTHER_CORE	01xxH
DATA_IN	xx33H	L3_OTHER_CORE_HIT	02xxH
DEMAND_DATA	xx03H	L3_OTHER_CORE_HITM	04xxH
DEMAND_DATA_RD	xx01H	LOCAL_CACHE	07xxH
DEMAND_IFETCH	xx04H	LOCAL_CACHE_DRAM	47xxH
DEMAND_RFO	xx02H	LOCAL_DRAM	40xxH
OTHER ¹	xx80H	REMOTE_CACHE	18xxH
PF_DATA	xx30H	REMOTE_CACHE_DRAM	38xxH
PF_DATA_RD	xx10H	REMOTE_CACHE_HIT	10xxH
PF_IFETCH	xx40H	REMOTE_CACHE_HITM	08xxH
PF_RFO	xx20H	REMOTE-DRAM	20xxH
PREFETCH	xx70H		

NOTES:

1. The PMU may report incorrect counts with setting MSR_OFFCORE_RSP_0 to the value of 4080H. Non-temporal stores to the local DRAM is not reported in the count.

B.4.3.5 Measuring Per-Core Bandwidth

Measuring the bandwidth of all memory traffic for an individual core is complicated, the core PMU and uncore PMU do provide capability to measure the important components of per-core bandwidth.

At the microarchitectural level, there is the buffering of L3 for writebacks/evictions from L2 (similarly to some degree with the non temporal writes). The eviction of modified lines from the L2 causes a write of the line back to the L3. The line in L3 is only written to memory when it is evicted from the L3 some time later (if at all). And L3 is part of the uncore sub-system, not part of the core.

The writebacks to memory due to eviction of modified lines from L3 cannot be associated with an individual core in the uncore PMU logic. The net result of this is that the total write bandwidth for all the cores can be measured with events in the uncore PMU. The read bandwidth and the non-temporal write bandwidth can be measured on a per core basis. In a system populated with two physical processor, the NUMA nature of memory bandwidth implies the measurement for those 2 components has to be divided into bandwidths for the core on a per-socket basis.

The per-socket read bandwidth can be measured with the events:

OFFCORE_RESPONSE_0.DATA_IFETCH.L3_MISS_LOCAL_DRAM.

OFFCORE_RESPONSE_0.DATA_IFETCH.L3_MISS_REMOTE_DRAM.

The total read bandwidth for all sockets can be measured with the event:

OFFCORE_RESPONSE_0.DATA_IFETCH.ANY_DRAM.

The per-socket non-temporal store bandwidth can be measured with the events:

OFFCORE_RESPONSE_0.OTHER.L3_MISS_LOCAL_CACHE_DRAM.

OFFCORE_RESPONSE_0.OTHER.L3_MISS_REMOTE_DRAM.

The total non-temporal store bandwidth can be measured with the event:

OFFCORE_RESPONSE_0.OTHER.ANY.CACHE_DRAM.

The use of "CACHE_DRAM" encoding is to work around the defect in the footnote of Table B-14. Note that none of the above includes the bandwidth associated with writebacks of modified cacheable lines.

B.4.3.6 Miscellaneous L1 and L2 Events for Cache Misses

In addition to the OFFCORE_RESPONSE_0 event and the precise events that will be discussed later, there are several other events that can be used as well. There are additional events that can be used to supplement the offcore_response_0 events, because the offcore_response_0 event code is supported on counter 0 only.

L2 misses can also be counted with the architecturally defined event LONGEST_LAT_CACHE_ACCESS, however as this event also includes requests due to the L1D and L2 hardware prefetchers, its utility may be limited. Some of the L2 access events can be used for both drilling down L2 accesses and L2 misses by type, in addition to the OFFCORE_REQUESTS events discussed earlier. The L2_RQSTS and L2_DATA_RQSTS events can be used to discern assorted access types. In all of the L2 access events the designation PREFETCH only refers to the L2 hardware prefetch. The designation DEMAND includes loads and requests due to the L1D hardware prefetchers.

The L2_LINES_IN and L2_LINES_OUT events have been arranged slightly differently than the equivalent events on Intel® Core™2 processors. The L2_LINES_OUT event can now be used to decompose the evicted lines by clean and dirty (i.e. a Writeback) and whether they were evicted by an L1D request or an L2 HW prefetch.

The event L2_TRANSACTIONS counts all interactions with the L2.

Writes and locked writes are counted with a combined event, L2_WRITE.

The details of the numerous derivatives of L2_RQSTS, L2_DATA_RQSTS, L2_LINES_IN, L2_LINES_OUT, L2_TRANSACTIONS, L2_WRITE, can be found under event codes 24H, 26H, F1H, F2H, F0H, and 27H at: <https://perfmon-events.intel.com/>.

B.4.3.7 TLB Misses

The next largest set of memory access delays are associated with the TLBs when linear-to-physical address translation is mapped with a finite number of entries in the TLBs. A miss in the first level TLBs results in a very small penalty that can usually be hidden by the OOO execution and compiler's scheduling. A miss in the shared TLB results in the Page Walker being invoked and this penalty can be noticeable in the execution.

The (non-PEBS) TLB miss events break down into three sets:

- DTLB misses and its derivatives are programmed with event code 49H.
- Load DTLB misses and its derivatives are programmed with event code 08H.
- ITLB misses and its derivatives are programmed with event code 85H.

Store DTLB misses can be evaluated from the difference of the DTLB misses and the Load DTLB misses. Each then has a set of sub events programmed with the Umask value. The Umask details of the numerous derivatives of the above events are listed at: <https://perfmon-events.intel.com/>.

B.4.3.8 L1 Data Cache

There are PMU events that can be used to analyze L1 data cache operations. These events can only be counted with the first 2 of the 4 general counters, i.e. IA32_PMC0 and IA32_PMC1. Most of the L1D events are self explanatory.

The total number of references to the L1D can be counted with L1D_ALL_REF, either just cacheable references or all. The cacheable references can be divided into loads and stores with L1D_CACHE_LOAD and L1D_CACHE.STORE. These events are further subdivided by MESI states through their Umask values, with the I state references indicating the cache misses.

The evictions of modified lines in the L1D result in writebacks to the L2. These are counted with the L1D_WB_L2 events. The Umask values break these down by the MESI state of the version of the line in the L2.

The locked references can be counted also with the L1D_CACHE_LOCK events. Again these are broken down by MES states for the lines in L1D.

The total number of lines brought into L1D, the number that arrived in an M state and the number of modified lines that get evicted due to receiving a snoop are counted with the L1D event and its Umask variations.

The L1D events are listed under event codes 28H, 40H, 41H, 42H, 43H, 48H, 4EH, 51H, 52H, 53H, 80H, and 83H at: <https://perfmon-events.intel.com/>.

There are few cases of loads not being able to forward from active store buffers. The predominant situations have to do with larger loads overlapping smaller stores. There is not event that detects when this occurs. There is also a “false store forwarding” case where the addresses only match in the lower 12 address bits. This is sometimes referred to as 4K aliasing. This can be detected with the event “PARTIAL_ADDRESS_ALIAS” which has event code 07H and Umask 01H.

B.4.4 Frontend Monitoring Events

Branch misprediction effects can sometimes be reduced through code changes and enhanced inlining. Most other **Frontend** performance limitations have to be dealt with by the code generation. The analysis of such issues is mostly of use by compiler developers.

B.4.4.1 Branch Mispredictions

In addition to branch retired events that was discussed in conjunction with PEBS in Section B.4.3.3. These are enhanced by use of the LBR to identify the branch location to go along with the target location captured in the PEBS buffer. Aside from those usage, many other PMU events (event code E6, E5, E0, 68, 69) associated with branch predictions are more relevant to hardware design than performance tuning.

Branch mispredictions are not in and of themselves an indication of a performance bottleneck. They have to be associated with dispatch stalls and the instruction starvation condition, UOPS_ISSUED:C1:I1 – RESOURCE_STALLS.ANY. Such stalls are likely to be associated with ICache misses and ITLB misses. The precise ITLB miss event can be useful for such issues. The ICache and ITLB miss events are listed under event code 80H, 81H, 82H, 85H, AEH.

B.4.4.2 Frontend Code Generation Metrics

The remaining **Frontend** events are mostly of use in identifying when details of the code generation interact poorly with the instructions decoding and uop issue to the OOO engine. Examples are length changing prefix issues associated with the use of 16 bit immediates, rob read port stalls, instruction alignment interfering with the loop detection and instruction decoding bandwidth limitations. The activity

of the LSD is monitored using CMASK values on a signal monitoring activity. Some of these events are listed under event code 17H, 18H, 1EH, 1FH, 87H, A6H, A8H, D0H, D2H at:

<https://perfmon-events.intel.com/>.

Some instructions (FSIN, FCOS, and other transcendental instructions) are decoded with the assistance of MS-ROM. Frequent occurrences of instructions that required assistance of MS-ROM to decode complex uop flows are opportunity to improve instruction selection to reduce such occurrences. The UOPS_DECODED.MS event can be used to identify code regions that could benefit from better instruction selection.

Other situations that can trigger this event are due to FP assists, like performing a numeric operation on denormalized FP values or QNaNs. In such cases the penalty is essentially the uops required for the assist plus the pipeline clearing required to ensure the correct state.

Consequently this situation has a very clear signature consisting of MACHINE_CLEAR.CYCLES and uops being inserted by the microcode sequencer, UOPS_DECODED.MS. The execution penalty being the sum of these two contributions. The event codes for these are listed under D1H and C3H.

B.4.5 Uncore Performance Monitoring Events

The uncore sub-system includes the L3, IMC and Intel QPI units in the diagram shown in Figure B-4. Within the uncore sub-system, the uncore PMU consists of eight general-purpose counters and one fixed counter. The fixed counter in uncore monitors the unhalting clock cycles in the uncore clock domain, which runs at a different frequency than the core.

The uncore cannot by itself generate a PMI interrupt. While the core PMU can raise PMI at a per-logical-processor specificity, the uncore PMU can cause PMI at a per-core specificity using the interrupt hardware in the processor core. When an uncore counter overflows, a bit pattern is used to specify which cores should be signaled to raise a PMI. The uncore PMU is unaware of the core, Processor ID or Thread ID that caused the event that overflowed a counter. Consequently the most reasonable approach for sampling on uncore events is to raise a PMI on all the logical processors in the package.

There are a wide variety of events that monitor queue occupancies and inserts. There are others that count cacheline transfers, dram paging policy statistics, snoop types and responses, and so on. The uncore is the only place the total bandwidth to memory can be measured. This will be discussed explicitly after all the uncore components and their events are described.

B.4.5.1 Global Queue Occupancy

Each processor core has a super queue that buffers requests of memory access traffic due to an L2 miss. The uncore has a global queue (GQ) to service transaction requests from the processor cores and buffers data traffic that arrive from L3, IMC, or Intel QPI links.

Within the GQ, there are 3 "trackers" in the GQ for three types of transactions:

- On-package read requests, its tracker queue has 32 entries.
- On-package writeback requests, its tracker queue has 16 entries.
- Requests that arrive from a "peer", its tracker queue has 12 entries.

A "peer" refers to any requests coming from the Intel® QuickPath Interconnect.

The occupancies, inserts, cycles full and cycles not empty for all three trackers can be monitored. Further as load requests go through a series of stages the occupancy and inserts associated with the stages can also be monitored, enabling a "cycle accounting" breakdown of the uncore memory accesses due to loads.

When an uncore counter is first programmed to monitor a queue occupancy, for any of the uncore queues, the queue must first be emptied. This is accomplished by the driver of the monitoring software tool issuing a bus lock. This only needs to be done when the counter is first programmed. From that point on the counter will correctly reflect the state of the queue, so it can be repeatedly sampled for example without another bus lock being issued.

The uncore events that monitor GQ allocation (UNC_GQ_ALLOC) and GQ tracker occupancy (UNC_GQ_TRACKER_OCCUP) are listed under the event code 03H and 02H at: <https://perfmon-events.intel.com/>. The selection between the three trackers is specified from the Umask value. The mnemonic of these derivative events use the notation: "RT" signifying the read tracker, "WT", the write tracker and "PPT" the peer probe tracker.

Latency can be measured by the average duration of the queue occupancy, if the occupancy stops as soon as the data has been delivered. Thus the ratio of $\text{UNC_GQ_TRACKER_OCCUP.X/UNC_GQ_ALLOC.X}$ measures an average duration of queue occupancy, where 'X' represents a specific Umask value. The total occupancy period of the read tracker as measured by:

$$\text{Total Read Period} = \text{UNC_GQ_TRACKER_OCCUP.RT/UNC_GQ_ALLOC.RT}$$

Is longer than the data delivery latency due to it including time for extra bookkeeping and cleanup. The measurement:

$$\text{LLC response Latency} = \text{UNC_GQ_TRACKER_OCCUP.RT_TO_LLC_RESP} / \text{UNC_GQ_ALLOC.RT_TO_LLC_RESP}$$

is essentially a constant. It does not include the total time to snoop and retrieve a modified line from another core for example, just the time to scan the L3 and see if the line is or is not present in this socket.

An overall latency for an L3 hit is the weighted average of three terms:

- The latency of a simple hit, where the line has only been used by the core making the request.
- The latencies for accessing clean lines by multiple cores.
- The latencies for accessing dirty lines that have been accessed by multiple cores.

These three components of the L3 hit for loads can be decomposed using the derivative events of OFFCORE_RESPONSE:

- OFFCORE_RESPONSE_0.DEMAND_DATA.L3_HIT_NO_OTHER_CORE.
- OFFCORE_RESPONSE_0.DEMAND_DATA.L3_HIT_OTHER_CORE_HIT.
- OFFCORE_RESPONSE_0.DEMAND_DATA.L3_HIT_OTHER_CORE_HITM.

The event OFFCORE_RESPONSE_0.DEMAND_DATA.LOCAL_CACHE should be used as the denominator to obtain latencies. The individual latencies could have to be measured with microbenchmarks, but the use of the precise latency event will be far more effective as any bandwidth loading effects will be included.

The L3 miss component is the weighted average over three terms:

- The latencies of L3 hits in a cache on another socket (this is described in the previous paragraph).
- The latencies to local DRAM.
- The latencies to remote DRAM.

The local dram access and the remote socket access can be decomposed with more uncore events.

$$\text{Miss to fill latency} = \text{UNC_GQ_TRACKER_OCCUP.RT_LLC_MISS} / \text{UNC_GQ_ALLOC.RT_LLC_MISS}$$

The uncore GQ events using Umask value associated with *RTID* mnemonic allow the monitoring of a sub component of the Miss to fill latency associated with the communications between the GQ and the QHL.

There are uncore PMU events which monitor cycles when the three trackers are not empty (≥ 1 entry) or full. These events are listed under the event code 00H and 01H at: <https://perfmon-events.intel.com/>.

Because the uncore PMU generally does not differentiate which processor core causes a particular eventing condition, the technique of dividing the latencies by the average queue occupancy in order to determine a penalty does not work for the uncore. Overlapping entries from different cores do not result in overlapping penalties and thus a reduction in stalled cycles. Each core suffers the full latency independently.

To evaluate the correction on a per-core basis, the number of cycles is required for an entry from the core in question. A *NOT_EMPTY_CORE_N type event is required, however, there is no such event. Consequently, in the cycle decomposition one must use the full latency for the estimate of the penalty. As has been stated before it is best to use the PEBS latency event as the data sources are also collected with the latency for the individual sample.

The individual components of the read tracker, discussed above, can also be monitored as busy or full by setting the CMask value to 1 or 32 and applying it to the assorted read tracker occupancy events.

Table B-15. Uncore PMU Events for Occupancy Cycles

Uncore PMU Events	CMask	Umask	Event Code
UNC_GQ_TRACKER_OCCUP.RT_L3_MISS_FULL	32	02H	02H
UNC_GQ_TRACKER_OCCUP.RT_TO_L3_RESP_FULL	32	04H	02H
UNC_GQ_TRACKER_OCCUP.RT_TO_RTID_ACCQUIRED_FULL	32	08H	02H
UNC_GQ_TRACKER_OCCUP.RT_L3_MISS_BUSY	1	02H	02H
UNC_GQ_TRACKER_OCCUP.RT_TO_L3_RESP_BUSY	1	04H	02H
UNC_GQ_TRACKER_OCCUP.RT_TO_RTID_ACCQUIRED_BUSY	1	08H	02H

B.4.5.2 Global Queue Port Events

The GQ data buffer traffic controls the flow of data to and from different sub-systems via separate ports:

- Core traffic: two ports handles data traffic, each port dedicated to a pair of processor cores.
- L3 traffic: one port service L3 data traffic.
- Intel QPI traffic: one service traffic to QPI logic.
- IMC traffic: one service data traffic to integrated memory controller.

The ports for L3 and core traffic transfer a fixed number of bits per cycle. However the Intel® QuickPath Interconnect protocols can result in either 8 or 16 bytes being transferred on the read Intel QPI and IMC ports. Consequently these events cannot be used to measure total data transfers and bandwidths.

The uncore PMU events that can distinguish traffic flow are listed under the event code 04H and 05H at: <https://perfmon-events.intel.com/>.

B.4.5.3 Global Queue Snoop Events

Cacheline requests from the cores or from a remote package or the I/O Hub are handled by the GQ. When the uncore receives a cacheline request from one of the cores, the GQ first checks the L3 to see if the line is on the package. Because the L3 is inclusive, this answer can be quickly ascertained. If the line is in the L3 and was owned by the requesting core, data can be returned to the core from the L3 directly. If the line is being used by multiple cores, the GQ will snoop the other cores to see if there is a modified copy. If so the L3 is updated and the line is sent to the requesting core.

In the event of an L3 miss, the GQ must send out requests to the local memory controller (or over the Intel QPI links) for the line. A request through the Intel QPI to a remote L3 (or remote DRAM) must be made if data exists in a remote L3 or does not exist in local DRAM. As each physical package has its own local integrated memory controller the GQ must identify the “home” location of the requested cacheline from the physical address. If the address identifies home as being on the local package then the GQ makes a simultaneous request to the local memory controller. If home is identified as belonging to the remote package, the request sent over the Intel QPI will also access the remote IMC.

The GQ handles the snoop responses for the cacheline requests that come in from the Intel® QuickPath Interconnect. These snoop traffic correspond to the queue entries in the peer probe tracker.

The snoop responses are divided into requests for locally homed data and remotely homed data. If the line is in a modified state and the GQ is responding to a read request, the line also must be written back to memory. This would be a wasted effort for a response to a RFO as the line will just be modified again, so no Writeback is done for RFOs.

The snoop responses of local home events that can be monitored by an uncore PMU are listed under event code 06H at: <https://perfmon-events.intel.com/>. The snoop responses of remotely home events are listed under event code 07H.

Some related events count the MESI transitions in response to snoops from other caching agents (processors or IOH). Some of these rely on programming MSR so they can only be measured one at a time, as there is only one MSR. The Intel performance tools will schedule this correctly by restricting these events to a single general uncore counter.

B.4.5.4 L3 Events

Although the number of L3 hits and misses can be determined from the GQ tracker allocation events, Several uncore PMU event is simpler to use. They are listed under event code 08H and 09H in the uncore event list at: <https://perfmon-events.intel.com/>.

The MESI states breakdown of lines allocated and victimized can also be monitored with LINES_IN, LINES_OUT events in the uncore using event code 0AH and 0BH. Details are listed at:

<https://perfmon-events.intel.com/>.

B.4.6 Intel QuickPath Interconnect Home Logic (QHL)

When a data misses L3 and causing the GQ of the uncore to send out a transaction request, the Intel QPI fabric will fulfill the request either from the local DRAM controller or from a remote DRAM controller in another physical package. The GQ must identify the "home" location of the requested cacheline from the physical address. If the address identifies home as being on the local package then the GQ makes a simultaneous request to the local memory controller, the Integrated memory controller (IMC). If home is identified as belonging to the remote package, the request is sent to the Intel QPI first and then to access the remote IMC.

The Intel QPI logic and IMC are distinct units in the uncore sub-system. The Intel QPI logic distinguish the local IMC relative to remote IMC using the concept of "caching agent" and "home agent". Specifically, the Intel QPI protocol considers each socket as having a "caching agent": and a "home agent":

- Caching Agent is the GQ and L3 in the uncore (or an IOH if present).
- Home Agent is the IMC.

An L3 miss result in simultaneous queries for the line from all the Caching Agents and the Home agent (wherever it is).

QHL requests can be superseded when another source can supply the required line more quickly. L3 misses to locally homed lines, due to on package requests, are simultaneously directed to the QHL and Intel QPI. If a remote caching agent supplies the line first then the request to the QHL is sent a signal that the transaction is complete. If the remote caching agent returns a modified line in response to a read request then the data in dram must be updated with a writeback of the new version of the line.

There is a similar flow of control signals when the Intel QPI simultaneously sends a snoop request for a locally homed line to both the GQ and the QHL. If the L3 has the line, the QHL must be signaled that the transaction was completely by the L3/GQ. If the line in L3 (or the cores) was modified and the snoop request from the remote package was for a load, then a writeback must be completed by the QHL and the QHL forwards the line to the Intel QPI to complete the transaction.

Uncore PMU provides events for monitoring these cacheline access and writeback traffic in the uncore by using the QHL opcode matching capability. The uncore PMU event that uses the opcode matching capability is listed under event code 35H. Several of the more useful setting to program QHL opcode matching is shown in Table B-16.

Table B-16. Common QHL Opcode Matching Facility Programming

Load Latency Precise Events	MSR 0x396	Umask	Event Code
UNC_ADDR_OPCODE_MATCH.IOH.NONE	0	1H	35H
UNC_ADDR_OPCODE_MATCH.IOH.RSPFWDI	40001900_00000000	1H	35H
UNC_ADDR_OPCODE_MATCH.IOH.RSPFWD	40001A00_00000000	1H	35H
UNC_ADDR_OPCODE_MATCH.IOH.RSPIWB	40001D00_00000000	1H	35H
UNC_ADDR_OPCODE_MATCH.REMOTE.NONE	0	2H	35H
UNC_ADDR_OPCODE_MATCH.REMOTE.RSPFWDI	40001900_00000000	2H	35H
UNC_ADDR_OPCODE_MATCH.REMOTE.RSPFWD	40001A00_00000000	2H	35H
UNC_ADDR_OPCODE_MATCH.REMOTE.RSPIWB	40001D00_00000000	2H	35H
UNC_ADDR_OPCODE_MATCH.LOCAL.NONE	0	4H	35H
UNC_ADDR_OPCODE_MATCH.LOCAL.RSPFWDI	40001900_00000000	1H	35H
UNC_ADDR_OPCODE_MATCH.LOCAL.RSPFWD	40001A00_00000000	1H	35H
UNC_ADDR_OPCODE_MATCH.LOCAL.RSPIWB	40001D00_00000000	1H	35H

These predefined opcode match encodings can be used to monitor HITM accesses. It is the only event that allows profiling the code requesting HITM transfers.

The diagrams Figure B-8 through Figure B-15 show a series of Intel QPI protocol exchanges associated with Data Reads and Reads for Ownership (RFO), after an L3 miss, under a variety of combinations of the local home of the cacheline, and the MESI state in the remote cache. Of particular note are the cases where the data comes from the remote QHL even when the data was in the remote L3. These are the Read Data with the remote L3 having the line in an M state.

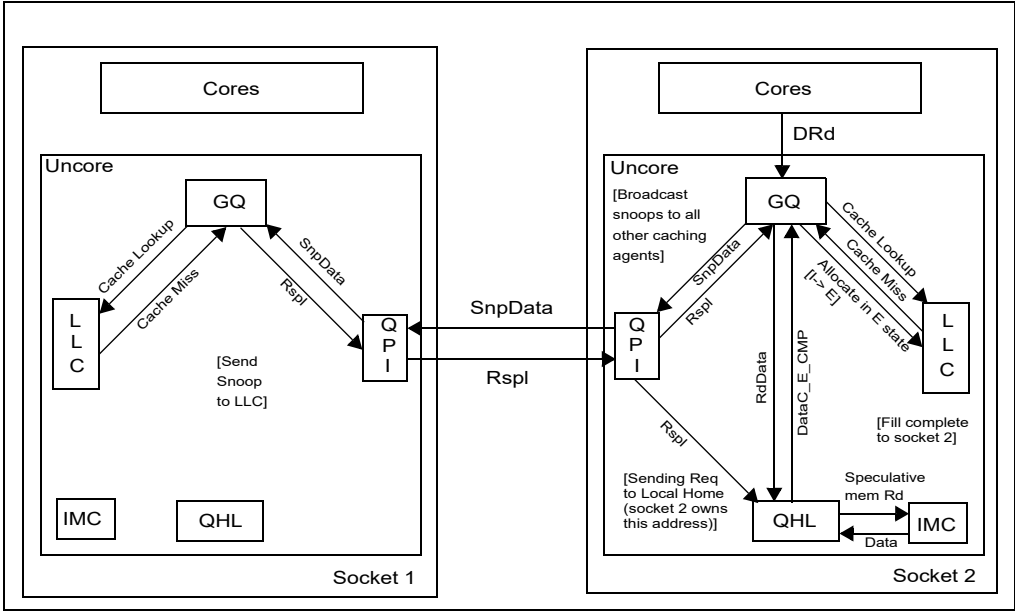

Figure B-8. RdData Request after LLC Miss to Local Home (Clean Rsp)

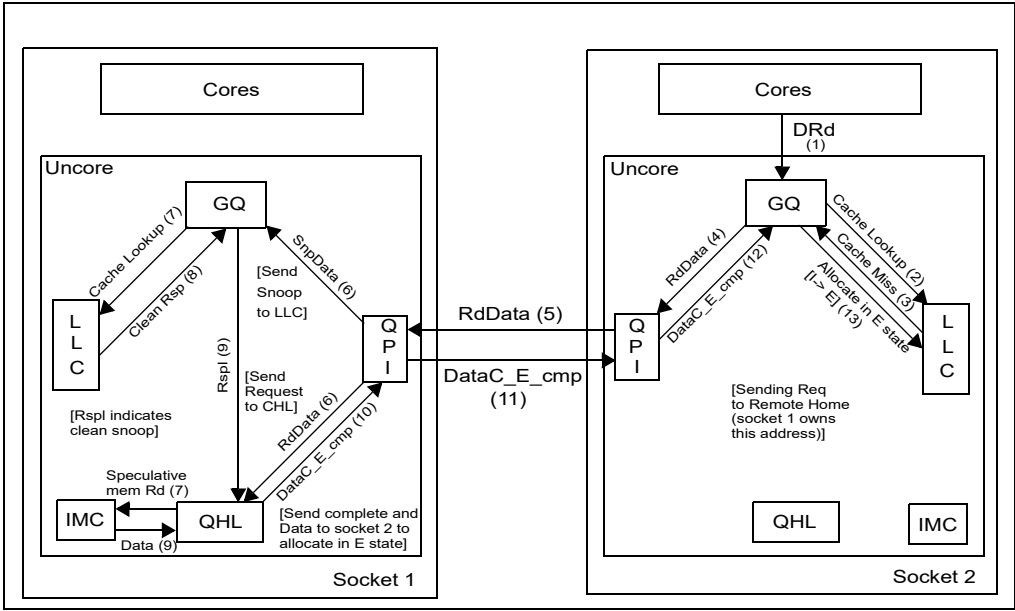

Figure B-9. RdData Request after LLC Miss to Remote Home (Clean Rsp)

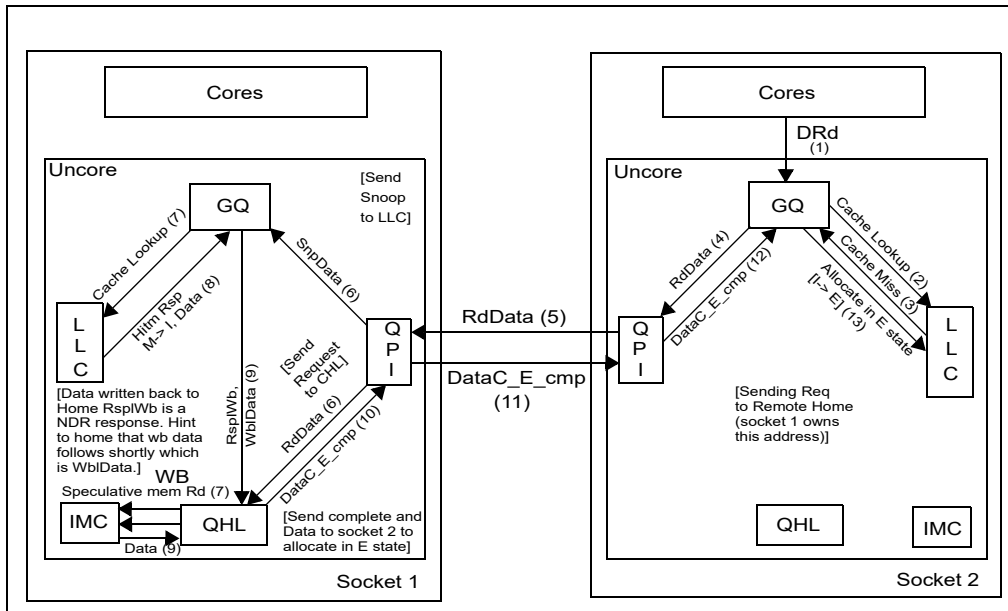

Figure B-10. RdData Request after LLC Miss to Remote Home (Hitm Response)

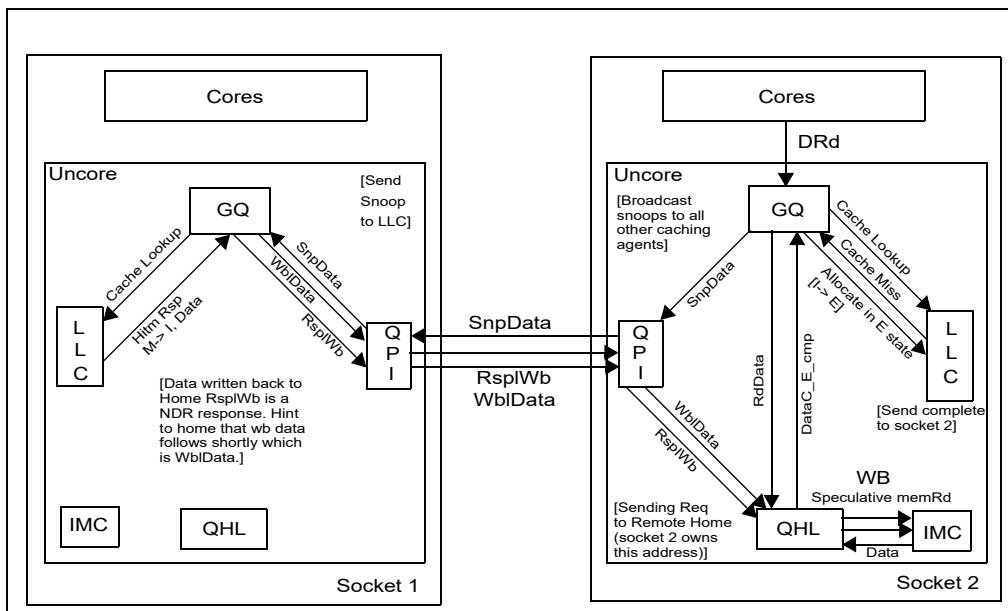

Figure B-11. RdData Request after LLC Miss to Local Home (Hitm Response)

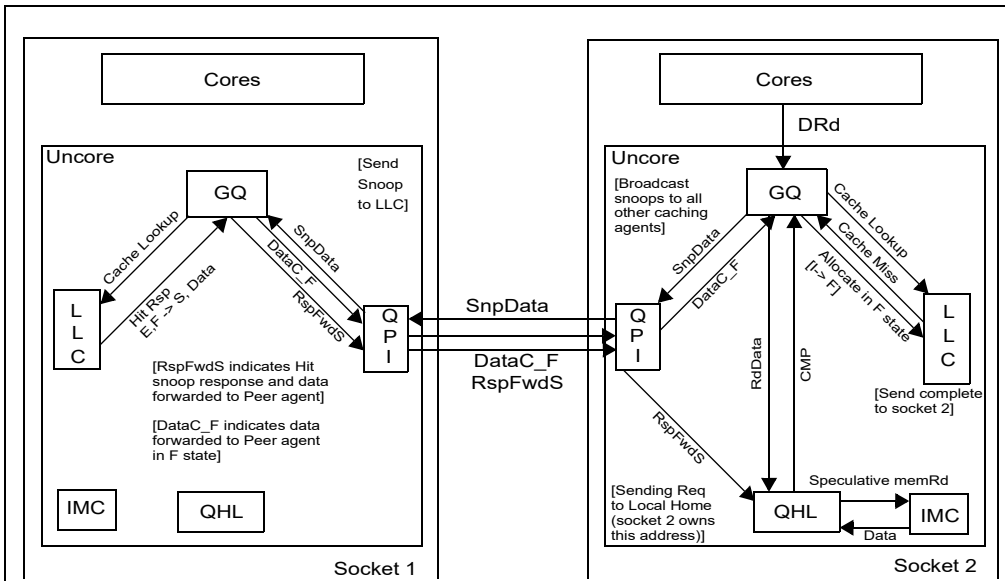

Figure B-12. RdData Request after LLC Miss to Local Home (Hit Response)

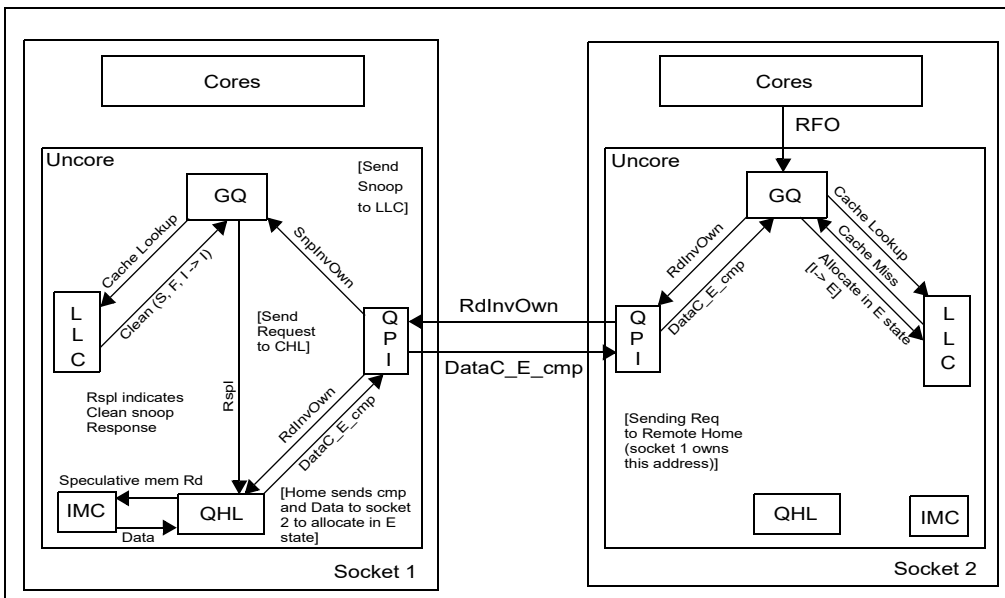

Figure B-13. RdInvOwn Request after LLC Miss to Remote Home (Clean Res)

evictions of modified lines in the L3. Thus a line used and modified by one core can end up being written back to dram when it is evicted due to a read on another core doing some completely unrelated task. Modified cached lines and writebacks of uncached lines (e.g. written with non temporal streaming stores) are handled differently in the uncore and their writebacks increment various events in different ways.

All full lines written to DRAM are counted by the `UNC_IMC_WRITES.FULL.*` events. This includes the writebacks of modified cached lines and the writes of uncached lines, for example generated by non-temporal SSE stores. The uncached line writebacks from a remote socket will be counted by `UNC_QHL_REQUESTS.REMOTE_WRITES`. The uncached writebacks from the local cores are not counted by `UNC_QHL_REQUESTS.LOCAL_WRITES`, as this event only counts writebacks of locally cached lines.

The `UNC_IMC_NORMAL_READS.*` events only count the reads. The `UNC_QHL_REQUESTS.LOCAL_READS` and the `UNC_QHL_REQUESTS.REMOTE_READS` count the reads and the "InvtoE" transactions, which are issued for the uncacheable writes, eg USWC/UC writes. This allows the evaluation of the uncacheable writes, by computing the difference of `UNC_QHL_REQUESTS.LOCAL_READS +`

`UNC_QHL_REQUESTS.REMOTE_READS - UNC_IMC_NORMAL_READS.ANY`.

These uncore PMU events that are useful for bandwidth evaluation are listed under event code 20H, 2CH, 2FH at: <https://perfmon-events.intel.com/>.

B.5 PERFORMANCE TUNING TECHNIQUES FOR SANDY BRIDGE MICROARCHITECTURE

This section covers various performance tuning techniques using performance monitoring events. Some techniques can be adapted in general to other microarchitectures, most of the performance events are specific to Sandy Bridge microarchitecture.

B.5.1 Correlating Performance Bottleneck to Source Location

Performance analysis tools often sample events to identify hot spots of instruction pointer addresses to help programmers identify source locations of potential performance bottlenecks.

The sampling technique requires a service routine to respond to the performance monitoring interrupt (PMI) generated from an overflow condition of the performance counter. There is a finite delay between the performance monitoring event detection of the eventing condition relative to the capture of the instruction pointer address. This is known as "skid". In other words, the event skid is the distance between the instruction or instructions that caused the issue and the instruction where the event is tagged. There are a few things to note in general on skid:

- Precise events have a defined event skid of 1 instruction to the next instruction retired. In the case when the offending instruction is a branch, the event is tagged with the branch target, which can be separated from the branch instruction. Thus sampling with precise events is likely to have less noise in pin-pointing source locations of bottlenecks.
- Using a performance event with eventing condition that carries a larger performance impact generally has a shorter skid and vice versa. The following examples illustrate this rule:
 - A store forward block issue can cause a penalty of more than 10 cycles. Sampling a store forward block event almost always tags to the next couple of instructions after the blocked load.
 - On the other hand, sampling loads that forwarded successfully with no penalty will have much larger skids, and less helpful for performance tuning.
- The closer the eventing condition is to the retirement of the instruction, the shorter the skid. The events in the **Frontend** of the pipeline tend to tag to instructions further from the responsible instruction than events that are taken at execution or retirement.
- Cycles counted with the event `CPU_CLK_UNHALTED.THREAD` often tag in greater counts on the instruction after larger bottlenecks in the pipeline. If cycles are accumulated on an instruction this is probably due to a bottleneck on the instruction at the previous instruction.

- It is very difficult to determine the source of issues with a low cost that occur in the **Frontend**. **Frontend** events can also skid to IPs that precede the actual instructions that are causing the issue.

B.5.2 Hierarchical Top-Down Performance Characterization Methodology and Locating Performance Bottlenecks

Sandy Bridge microarchitecture has introduced several performance events which help narrow down which portion of the microarhcitecture pipeline is stalled. This starts with a hierarchical approach to characterize a workload of where CPU cycles are spent in the microarchitecture pipelines. At the top level, there are four areas to attribute CPU cycles; these are described below. To determine what portion of the pipeline is stalled, the technique looks at a buffer that queues the micro-ops supplied by the front end and feeds the out-of-order back end (see Section E.2.1). This buffer is called the micro-op queue. From the micro-op queue viewpoint, there may be four different types of stalls:

- **Front end stalls** - The front end is delivering less than four micro-ops per cycle when the back end of the pipeline is requesting micro-ops. When these stalls happen, the rename/allocate part of the OOO engine will starved. Thus, execution is said to be front end bound.
- **Back end stalls** - No micro-ops are being delivered from the micro-op queue due to lack of required resources for accepting more micro-ops in the back end of the pipeline. When these stalls happen, execution is said to be back end bound.
- **Bad speculation** - The pipeline performs speculative execution of instructions that never successfully retire. The most common case is a branch misprediction where the pipeline predicts a branch target in order to keep the pipeline full instead of waiting for the branch to execute. If the processor prediction is incorrect it has to flush the pipeline without retiring the speculated instructions.
- **Retiring** - The micro-op queue delivers micro-ops that eventually retire. In the common case, the micro-ops originate from the program code. One exception is with assists where the microcode sequencer generates micro-ops to deal with issues in the pipeline.

The following figure illustrates how the execution opportunities are logically divided.

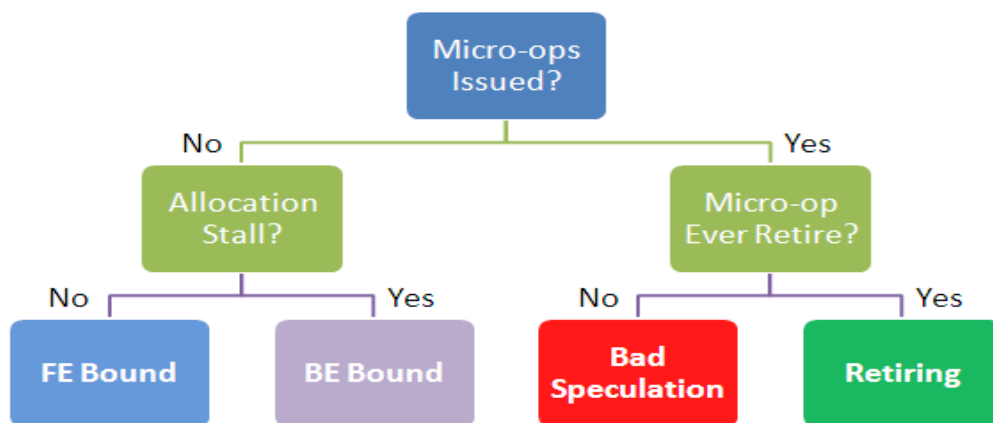

It is possible to estimate the amount of execution slots spent in each category using the following formulas in conjunction with core PMU performance events in Sandy Bridge microarchitecture:

```
%FE_Bound =
    100 * (IDQ_UOPS_NOT_DELIVERED.CORE / N);
%Bad_Speculation =
    100 * ((UOPS_ISSUED.ANY - UOPS_RETIRED.RETIRE_SLOTS + 4 *
    INT_MISC.RECOVERY_CYCLES) / N);
%Retiring = 100 * (UOPS_RETIRED.RETIRE_SLOTS / N);
%BE_Bound = 100 * (1 - (FE_Bound + Retiring + Bad_Speculation));
```

N represents total execution slots opportunities. Execution opportunities are the number of cycles multiplied by four.

- **N** = 4*CPU_CLK_UNHALTED.THREAD

The following sections explain the source for penalty cycles in three categories: back end stalls, **Frontend** stalls and bad speculation. They use formulas that can be applied to process, module, function, and instruction granularity.

B.5.2.1 Back End Bound Characterization

Once the %BE_Bound metric raises concern, a user may need to drill down to the next level of possible issues in the back end. Our methodology examines back end stalls based on execution unit occupation at every cycle. Naturally, optimal performance may be achieved when all execution resources are kept busy. Currently, this methodology splits **back end bound** issues into two categories: **memory bound** and **core bound**.

“Memory bound” corresponds to stalls related to the memory subsystem. For example, cache misses may eventually cause execution starvation. On the other hand, “core bound” which corresponds to stalls due to either the Execution- or OOO-clusters, is a bit trickier. These stalls can manifest either with execution starvation or non-optimal execution ports utilization. For example, a long latency divide operation may serialize the execution causing execution starvation for some period, while pressure on an execution port that serves specific types of uops, might manifest as small number of ports utilized in a cycle.

Use performance monitoring events at the execution units to calculate:

```
%BE_Bound_at_EXE =
    (CYCLE_ACTIVITY.CYCLES_NO_EXECUTE + UOPS_EXECUTED.THREAD:c1 -
    UOPS_EXECUTED.THREAD:c2) / CLOCKS
```

CYCLE_ACTIVITY.CYCLES_NO_EXECUTE counts complete starvation cycles where no uop is executed whatsoever.

UOPS_EXECUTED.THREAD:c1 and UOPS_EXECUTED.THREAD:c2 count cycles where at least 1- and 2-uops were executed in a cycle, respectively. Hence the event count difference measures the cycles when the OOO back end could execute only 1 uop.

The **%BE_Bound_at_EXE** metric is counted at execution unit pipestages so the number would not match the Backend_Bound ratio which is done at the allocation stage. However, redundancy is good here as one can use both counters to confirm the execution is indeed back end bound (both should be high).

B.5.2.2 Core Bound Characterization

A “back end bound” workload can be identified as “core bound” by the following metric:

```
%Core_Bound = %Backend_Bound_at_EXE - %Memory_Bound
```

The metric “%Memory_Bound” is described in Section B.5.2.3. Once a workload is identified as “core bound”, the user may want to drill down into OOO or Execution related issues through their transitional targeted performance counter, like, for example, execution ports pressure, or use of FP-chained long-latency arithmetic operations.

B.5.2.3 Memory Bound Characterization

More primitive methods of characterizing performance issues in the memory pipeline tend to use naïve calculations to estimate the penalty of memory stalls. Usually the number of misses to a given cache level access is multiplied by a predefined latency for that cache level per the CPU specifications, in order to get an estimation for the penalty. While this might work for an in-order processor, it often over-estimates the contribution of memory accesses on CPU cycles for highly out-of-order processors, because memory accesses tend to overlap and the scheduler manages to hide a good portion of the latency. The scheduler might be able to hide some of the memory access stalls by keeping the execution stalls busy with uops that do not require the memory access data. Thus penalty for a memory access is when the scheduler has nothing more ready to dispatch and the execution units get starved as a result. It is likely that further uops are either waiting for memory access data, or depend on other non-dispatched uops.

In Ivy Bridge microarchitecture, a new performance monitoring event "CYCLE_ACTIVITY.STALLS_LDM_PENDING" is provided to estimate the exposure of memory accesses. It is used to define the "memory bound" metric. This event measures the cycles when there is a non-completed in-flight memory demand load coincident with execution starvation. Note that only demand load operations are accounted for, as uops do not typically wait for (direct) completion of stores or HW prefetches:

%Memory Bound = CYCLE_ACTIVITY.STALLS_LDM_PENDING / CLOCKS

If a workload is memory bound, it is possible to further characterize its performance characteristic with respect to the contribution of the cache hierarchy and DRAM system memory.

L1 cache has typically the shortest latency which is comparable to ALU units' stalls that are the shortest among all stalls. Yet in certain cases, like loads blocked on older stores, a load might suffer high latency while eventually being satisfied by the L1. There are no fill-buffers allocated for L1 hits; use the LDM stalls sub-event instead because it accounts for any non-completed load.

%L1 Bound = (CYCLE_ACTIVITY.STALLS_LDM_PENDING - CYCLE_ACTIVITY.STALLS_L1D_PENDING) / CLOCKS

As explained above, L2 Bound is detected as:

%L2 Bound = (CYCLE_ACTIVITY.STALLS_L1D_PENDING - CYCLE_ACTIVITY.STALLS_L2_PENDING) / CLOCKS

In principle, L3 Bound can be calculated similarly by subtracting out the L3 miss contribution. However an equivalent event to measure L3_PENDING is not available. Nevertheless, *it is possible to infer* an estimate using L3_HIT and L3_MISS load count events in conjunction with a correction factor. This estimation could be tolerated as the latencies are longer on L3 and Memory. The correction factor MEM_L3_WEIGHT is approximately the external memory to L3 cache latency ratio. A factor of 7 can be used for the third generation Intel Core processor family. Note this correction factor has some dependency on CPU and Memory frequencies.

%L3 Bound = CYCLE_ACTIVITY.STALLS_L2_PENDING * L3_Hit_fraction / CLOCKS

Where L3_Hit_fraction is:

MEM_LOAD_UOPS_RETIRED.LLC_HIT / (MEM_LOAD_UOPS_RETIRED.LLC_HIT + MEM_L3_WEIGHT * MEM_LOAD_UOPS_MISC_RETIRED.LLC_MISS)

To estimate the exposure of DRAM traffic on third generation Intel Core processors, the remainder of L2_PENDING is used for MEM Bound:

%MEM Bound = CYCLE_ACTIVITY.STALLS_L2_PENDING * L3_Miss_fraction / CLOCKS

Where L3_Miss_fraction is:

WEIGHT * MEM_LOAD_UOPS_MISC_RETIRED.LLC_MISS / (MEM_LOAD_UOPS_RETIRED.LLC_HIT + WEIGHT * MEM_LOAD_UOPS_MISC_RETIRED.LLC_MISS)

Sometimes it is meaningful to refer to all memory stalls outside the core as Uncore Bound:

%Uncore Bound = CYCLE_ACTIVITY.STALLS_L2_PENDING / CLOCKS

B.5.3 Back End Stalls

Back end stalls have two main sources: memory sub-system stalls and execution stalls. As a first step to understanding the source of back end stalls, use the resource stall event.

Before putting micro-ops into the scheduler, the rename stage has to have certain resources allocated. When an application encounters a significant bottleneck at the back end of the pipeline, it runs out of these resources as the pipeline backs up. The RESOURCE_STALLS event tracks stall cycles when a resource could not be allocated. The event breaks up each resource into a separate sub-event so you can track which resource is not available for allocation. Counting these events can help identifying the reason for issues in the back end of the pipeline.

The resource stall ratios described below can be accomplished at process, module, function and even instruction granularities with the cycles, counted by CPU_CLK_UNHALTED.THREAD, representing the penalty tagged at the same granularity.

Usages of Specific Events

RESOURCE_STALLS.ANY - Counts stall cycles that the rename stage is unable to put micro-ops into the scheduler, due to lack of resources that have to be allocated at this stage. The event skid tends to be low since it is close to the retirement of the blocking instruction. This event accounts for all stalls counted by other RESOURCE_STALL sub events and also includes the sub-events of RESOURCE_STALLS2. If this ratio is high, count the included sub-events to get a better isolation of the reason for the stall.

```
%RESOURCE_STALLS.COST =
    100 * RESOURCE_STALLS.ANY / CPU_CLK_UNHALTED.THREAD;
```

RESOURCE_STALLS.SB - Occurs when a store micro-op is ready for allocation and all store buffer entries are in use, usually due to long latency stores in progress. Typically this event tags to the IP after the store instruction that is stalled at allocation.

```
%RESOURCE_STALLS.SB.COST =
    100 * RESOURCE_STALLS.SB / CPU_CLK_UNHALTED.THREAD;
```

RESOURCE_STALLS.LB - Counts cycles in which a load micro-op is ready for allocation and all load buffer entries are taken, usually due to long latency loads in progress. In many cases the queue to the scheduler becomes full by micro-ops that depend on the long latency loads, before the load buffer gets full.

```
%RESOURCE_STALLS.LB.COST =
    100 * RESOURCE_STALLS.LB / CPU_CLK_UNHALTED.THREAD;
```

In the above cases the event RESOURCE_STALLS.RS will often count in parallel. The best methodology to further investigate loss in data locality is the high cache line replacement study described in Section B.5.4.2, concentrating on L1 DCache replacements first

RESOURCE_STALLS.RS - Scheduler slots are typically the first resource that runs out when the pipeline is backed up. However, this can be due to almost any bottleneck in the back end, including long latency loads and instructions backed up at the execute stage. Thus it is recommended to investigate other resource stalls, before digging into the stalls tagged to lack of scheduler entries. The skid tends to be low on this event.

```
%RESOURCE_STALLS.RS.COST =
    100 * RESOURCE_STALLS.RS / CPU_CLK_UNHALTED.THREAD;
```

RESOURCE_STALLS.ROB - Counts cycles when allocation stalls because all the reorder buffer (ROB) entries are taken. This event occurs less frequently than the RESOURCE_STALLS.RS and typically indicates that the pipeline is being backed up by a micro-op that is holding all younger micro-ops from retiring because they have to retire in order.

```
%RESOURCE_STALLS.ROB.COST =
    100 * RESOURCE_STALLS.ROB / CPU_CLK_UNHALTED.THREAD;
```

RESOURCE_STALLS2.BOB_FULL - Counts when allocation is stalled due to a branch micro-op that is ready for allocation, but the number of branches in progress in the processor has reached the limit.

```
%RESOURCE_STALLS2.BOB.COST =
    100 * RESOURCE_STALLS2.BOB / CPU_CLK_UNHALTED.THREAD;
```

B.5.4 Memory Sub-System Stalls

The following subsections discuss using specific performance monitoring events in Sandy Bridge microarchitecture to identify stalls in the memory sub-systems.

B.5.4.1 Accounting for Load Latency

The breakdown of load operation locality can be accomplished at any granularity including process, module, function and instruction. When you find that a load instruction is a bottleneck, investigate it further with the precise load breakdown. If this does not explain the bottleneck, check for other issues which can impact loads.

You can use these events to estimate the costs of the load causing a bottleneck, and to obtain a percentage breakdown of memory hierarchy level. Not all tools provide support for precise event sampling. If the precise version (event name ends with a suffix PS) of these event is not supported in a given tool, you can use the non-precise version.

The precise load events tag the event to the next instruction retired (IP+1). See the load latency at each hierarchy level in Table E-13.

Required events

MEM_LOAD_UOPS_RETIRED.L1_HIT_PS - Counts demand loads that hit the first level of the data cache, the L1 DCache. Demand loads are non-speculative load micro-ops.

MEM_LOAD_UOPS_RETIRED.L2_HIT_PS - Counts demand loads that hit the 2nd level cache, the L2.

MEM_LOAD_UOPS_RETIRED.LLC_HIT_PS - Counts demand loads that hit the 3rd level shared cache, the LLC.

MEM_LOAD_UOPS_LLC_HIT_RETIRED.XSNP_MISS - Counts demand loads that hit the 3rd level shared cache and are assumed to be present also in a cache of another core but the cache line was already evicted from there.

MEM_LOAD_UOPS_LLC_HIT_RETIRED.XSNP_HIT_PS - Counts demand loads that hit a cache line in a cache of another core and the cache line has not been modified.

MEM_LOAD_UOPS_LLC_HIT_RETIRED.XSNP_HITM_PS - Counts demand loads that hit a cache line in the cache of another core and the cache line has been written to by that other core. This event is important for many performance bottlenecks that can occur in multi-threaded applications, such as lock contention and false sharing.

MEM_LOAD_UOPS_MISC_RETIRED.LLC_MISS_PS - Counts demand loads that missed the LLC. This means that the load is usually satisfied from memory in client system.

MEM_LOAD_UOPS_RETIRED.HIT_LFB_PS - Counts demand loads that hit in the line fill buffer (LFB). A LFB entry is allocated every time a miss occurs in the L1 DCache. When a load hits at this location it means that a previous load, store or hardware prefetch has already missed in the L1 DCache and the data fetch is in progress. Therefore the cost of a hit in the LFB varies. This event may count cache-line split loads that miss in the L1 DCache but do not miss the LLC.

On 32-byte Intel AVX loads, all loads that miss in the L1 DCache show up as hits in the L1 DCache or hits in the LFB. They never show hits on any other level of memory hierarchy. Most loads arise from the line fill buffer (LFB) when Intel AVX loads miss in the L1 DCache.

Precise Load Breakdown

The percentage breakdown of each load source can be tagged at any granularity including a single IP, function, module, or process. This is particularly useful at a single instruction to determine the breakdown of where the load was found in the cache hierarchy. The following formula shows how to calculate the percentage of time a load was satisfied by the LLC. Similar formulas can be used for all other hierarchy levels.

```
%LocL3.HIT =
    100 * MEM_LOAD_UOPS_RETIRED.LLC_HIT_PS / $SumOf_PRECISE_LOADS;
```

```

$SumOf_PRECISE_LOADS =
MEM_LOAD_UOPS_RETIRED.HIT_LFB_PS + MEM_LOAD_UOPS_RETIRED.L1_HIT_PS +
MEM_LOAD_UOPS_RETIRED.L2_HIT_PS + MEM_LOAD_UOPS_RETIRED.LLC_HIT_PS +
MEM_LOAD_UOPS_LLC_HIT_RETIRED.XSNP_MISS +
MEM_LOAD_UOPS_LLC_HIT_RETIRED.XSNP_HIT_PS +
MEM_LOAD_UOPS_LLC_HIT_RETIRED.XSNP_HITM_PS +
MEM_LOAD_UOPS_MISC_RETIRED.LLC_MISS_PS;

```

Estimated Load Penalty

The formulas below help estimating to what degree loads from a certain memory hierarchy are responsible for a slowdown. The CPU_CLK_UNHALTED.THREAD programmable event represents the penalty in cycles tagged at the same granularity. At the instruction level, the cycle cost of an expensive load tends to only skid one IP, similar to the precise event. The calculations below apply to any granularity process, module, function or instruction, since the events are precise. Anything representing 10%, or higher, of the total clocks in a granularity of interest should be investigated.

If the code has highly dependent loads you can use the MEM_LOAD_UOPS_RETIRED.L1_HIT_PS event to determine if the loads are hit by the five cycle latency of the L1 DCache.

Estimated cost of L2 latency

```
%L2.COST =
12 * MEM_LOAD_UOPS_RETIRED.L2_HIT_PS / CPU_CLK_UNHALTED.THREAD;
```

Estimated cost of L3 hits

```
%L3.COST =
26 * MEM_LOAD_UOPS_RETIRED.L3_HIT_PS / CPU_CLK_UNHALTED.THREAD;
```

Estimated cost of hits in the cache of other cores

```
%HIT.COST =
43 * MEM_LOAD_UOPS_LLC_HIT_RETIRED.XSNP_HIT_PS /
CPU_CLK_UNHALTED.THREAD;
```

Estimated cost of memory latency

```
%MEMORY.COST =
200 * MEM_LOAD_UOPS_MISC_RETIRED.LLC_MISS_PS /
CPU_CLK_UNHALTED.THREAD;
```

Actual memory latency can vary greatly depending on memory parameters. The amount of concurrent memory traffic often reduces the effect cost of a given memory hierarchy. Typically, the estimates above may be on the pessimistic side (like pointer-chasing situations).

Often, cache misses will manifest as delaying and bunching on the retirement of instructions. The precise loads breakdown can provide estimates of the distribution of hierarchy levels where the load is satisfied.

Given a significant impact from a particular cache level, the first step is to find where heavy cache line replacements are occurring in the code. This could coincide with your hot portions of code detected by the memory hierarchy breakdown, but often does not. For instance, regular traversal of a large data structure can unintentionally clear out levels of cache.

If hits of non modified or modified data in another core have high estimated cost and are hot at locations in the code, it can be due to locking, sharing or false sharing issues between threads.

If load latency in memory hierarchy levels further from the L1 DCache does not justify the amount of cycles spent on a load, try one of the following:

- • Eliminate **superfluous** load operations such as spilling general purpose registers to XMM registers rather than memory.
- Continue searching for issues impacting load instructions described in Section B.5.4.4.

B.5.4.2 Cache-line Replacement Analysis

When an application has many cache misses, it is a good idea to determine where cache lines are being replaced at the highest frequency. The instructions responsible for high amount of cache replacements are not always where the application is spending the majority of its time, since replacements can be driven by the hardware prefetchers and store operations which in the common case do not hold up the pipeline. Typically traversing large arrays or data structures can cause heavy cache line replacements.

Required events:

L1D.REPLACEMENT - Replacements in the 1st level data cache.

L2_LINES_IN.ALL - Cache lines being brought into the L2 cache.

Usages of events:

Identifying the replacements that potentially cause performance loss can be done at process, module, and function level. Do it in two steps:

- Use the precise load breakdown to identify the memory hierarchy level at which loads are satisfied and cause the highest penalty.
- Identify, using the formulas below, which portion of code causes the majority of the replacements in the level below the one that satisfies these high penalty loads.

For example, if there is high penalty due to loads hitting the LLC, check the code which is causing replacements in the L2 and the L1. In the formulas below, the nominators are the replacements accounted for a module or function. The sum of the replacements in the denominators is the sum of all replacements in a cache level for all processes. This enables you to identify the portion of code that causes the majority of the replacements.

L1D Cache Replacements

```
%L1D.REPLACEMENT =
    L1D.REPLACEMENT / SumOverAllProcesses(L1D.REPLACEMENT);
```

L2 Cache Replacements

```
%L2.REPLACEMENT =
    L2_LINES_IN.ALL / SumOverAllProcesses(L2_LINES_IN.ALL);
```

B.5.4.3 Lock Contention Analysis

The amount of contention on locks is critical in scalability analysis of multi-threaded applications. A typical ring3 lock almost always results in the execution of an atomic instruction. An atomic instruction is either an XCHG instruction involving a memory address or one of the following instructions with memory destination and lock prefix: ADD, ADC, AND, BTC, BTR, BTS, CMPXCHG, CMPXCH8B, DEC, INC, NEG, NOT, OR, SBB, SUB, XOR or XADD. Precise events enable you to get an idea of the contention on any lock. Many locking APIs start by an atomic instruction in ring3 and back off a contended lock by jumping into ring0. This means many locking APIs can be very costly in low contention scenarios. To estimate the amount of contention on a locked instruction, you can measure the number of times the cache line containing the memory destination of an atomic instruction is found modified in another core.

Required events:

MEM_UOPS_RETIRED.LOCK_LOADS_PS - Counts the number of atomic instructions which are retired with a precise skid of IP+1.

MEM_LOAD_UOPS_LLC_HIT_RETIRED.XSNP_HITM_PS - Counts the occurrences that the load hits a modified cache line in another core. This event is important for many performance bottlenecks that can occur in multi-core systems, such as lock contention, and false sharing.

Usages of events:

The lock contention factor gives the percentage of locked operations executed that contend with another core and therefore have a high penalty. Usually a lock contention factor over 5% is worth investigating on a hot lock. A heavily contended lock may impact the performance of multiple threads.

```
%LOCK.CONTENTION =
```

```
100 * MEM_LOAD_UOPS_LLC_HIT_RETIRED.XSNP_HITM_PS /
MEM_UOPS_RETIRED.LOCK_LOAD_PS;
```

B.5.4.4 Other Memory Access Issues

Store Forwarding Blocked

When store forwarding is not possible the dependent loads are blocked. The average penalty for store forward block is 13 cycles. Since many cases of store forwarding blocked were fixed in prior architectures, the most common case in code today involves storing to a smaller memory space than an ensuing larger load.

Required events:

LD_BLOCKS.STORE_FORWARD - Counts the number of times a store forward opportunity is blocked due to the inability of the architecture to forward a small store to a larger load and some rare alignment cases.

Usages of Events:

Use the following formula to estimate the cost of the store forward block. The event LD_BLOCKS.STORE_FORWARD tends to be tagged to the next IP after the attempted load, so it is recommended to look at this issue at the instruction level. However it is possible to inspect the ratio at any granularity: process, module, function or IP.

```
%STORE_FORWARD_BLOCK_COST =
100 * LD_BLOCKS.STORE_FORWARD * 13 / CPU_CLK_UNHALTED.THREAD;
```

After finding a load blocked from store-forwarding, the location of the store must also be found. Typically, about 60% of all store forwarded blocked issue are caused by stores in the last 10 instructions executed prior to the load.

The most common case in which store forward blocked is seen is a small store that is unable to forward to a larger load. For example, the code below generated writes to a byte pointer address and then reads from a four byte (dword) memory space:

```
and    byte ptr [ebx],7f
and    dword ptr [ebx],ecx
```

To fix a store forward block, it's best to fix the store operation and not the load.

Cache Line Splits

Beginning with Nehalem microarchitecture, the L1 DCache has split registers which enable it to handle loads and stores that span two cache lines in a faster manner. This puts the cost of split loads at about five cycles, as long as split registers are available, instead of the 20 cycles required in earlier microarchitectures. Handling of split stores handling is usually hidden, but if there are many of them they can stall allocation due to a full store buffer, or they can consume split registers that may be needed for handling split loads. Getting quantifiable gains from eliminating cache line splits is still achievable.

Required events:

MEM_UOPS_RETIRED.SPLIT_LOADS_PS - Counts the number of demand loads that span two cache lines. The event is precise.

MEM_UOPS_RETIRED.SPLIT_STORES_PS - Counts the number of stores that span two cache lines. The event is precise.

Usages of events:

Finding split loads is fairly easy because they usually tag the majority of their cost to the next IP which is executed. The ratio below can be used at any granularity: process, module, function, and IP after split.

```
%SPLIT_LOAD_COST =
100 * MEM_UOPS_RETIRED.SPLIT_STORES_PS * 5 / CPU_CLK_UNHALTED.THREAD;
```

Split store penalty is more difficult to find using an estimated cost, because in typical cases stores do not push out the retirement of instructions. To detect significant amount of split stores divide their number by the total number of stores retired at that IP.

SPLIT.STORE.RATIO =
MEM_UOPS_RETIRED.SPLIT_STORES_PS / MEM_UOPS_RETIRED.ANY_STORES_PS;

4k Aliasing

A 4k aliasing conflict between loads and stores causes a reissue on the load. Five cycles is used as an estimate in the model below.

Required Events:

LD_BLOCKS_PARTIAL.ADDRESS_ALIAS - Counts the number of loads that have partial address match with preceding stores, causing the load to be reissued.

Usages of events:

%4KALIAS.COST =
100 * LD_BLOCK_PARTIAL.ADDRESS_ALIAS * 5 / CPU_CLK_UNHALTED.THREAD;

Load and Store Address Translation

There are two levels of translation look-aside buffer (TLB) for linear to physical address translation. A miss in the DTLB, the first level TLB, that hits in the STLB, the second level TLB, incurs a seven cycle penalty.

Missing in the STLB requires the processor to walk through page table entries that contain the address translation. These walks have variable cost depending on the location of the page table entries. The walk duration is a fairly good estimate of the cost of STLB misses.

Required events:

DTLB_LOAD_MISSES.STLB_HIT - Counts loads that miss the DTLB and hit in the STLB. This event has a low skid and hence can be used at the IP level.

DTLB_LOAD_MISSES.WALK_DURATION - Duration of a page walks in cycles following STLB misses. Event skid is typically one instruction, enabling you to detect the issue at instruction, function, module or process granularities.

MEM_UOPS_RETIRED.STLB_MISS_LOADS_PS - Precise event for loads which have their translation miss the STLB. The event counts only the first load from a page that initiates the page walk.

Usage of events:

Cost of STLB hits on loads:

%STLB.HIT.COST =
100 * DTLB_LOAD_MISSES.STLB_HIT * 7 / CPU_CLK_UNHALTED.THREAD;

Cost of page walks:

%STLB.LOAD.MISS.WALK.COST =
100 * DTLB_LOAD_MISSES.WALK_DURATION / CPU_CLK_UNHALTED.THREAD;

Use the precise STLB miss event at the IP level to determine exactly which instruction and source line suffers from frequent STLB misses.

%STLB.LOAD.MISS =
100 * MEM_UOPS_RETIRED.STLB_MISS_LOADS_PS /
MEM_UOPS_RETIRED.ANY_LOADS_PS;

Large walk durations, of hundreds of cycles, are an indication that the page tables have been thrown out of the LLC. To determine the average cost of a page walk use the following ratio:

STLB.LOAD.MISS.AVGCOST =
DTLB_LOAD_MISSES.WALK_DURATION /
DTLB_LOAD_MISSES.WALK_COMPLETED;

To a lesser extent than loads, STLB misses on stores can be a bottleneck. If the store itself is a large bottleneck, cycles will tag to the next IP after the store.

```
%STLB.STORE.MISS =
    100 * MEM_UOPS_RETIRED.STLB_MISS_STORES_PS /
    MEM_UOPS_RETIRED.ANY_STORES_PS;
```

Reducing DTLB/STLB misses increases data locality. One may consider using an commercial-grade memory allocators to improve data locality. Compilers which offer profile guided optimizations may reorder global variables to increase data locality, if the compiler can operate on the whole module. For issues with a large amount of time spent in page walks, server and HPC applications may be able to use large pages for data.

B.5.5 Execution Stalls

The following subsections discuss using specific performance monitoring events in Sandy Bridge microarchitecture to identify stalls in the out-of-order engine.

B.5.5.1 Longer Instruction Latencies

Some microarchitectural changes manifested in longer latency for some legacy instructions in existing code. It is possible to detect some of these situations:

- Three-operand slow LEA instructions (see Section 3.5.1.2).
- Flags merge micro-op - These merges are primarily required by "shift cl" instructions (see Section 3.5.2.5).

These events tend to have a skid as high as a 10 instructions because the eventing condition is detected early in the pipeline.

Event usage:

To use this event effectively without being distracted by the event skid, you can use it to locate performance issue at the process, module and function granularities, but not at the instruction level. To identify issue at the instruction IP granularity, one can perform static analysis on the functions identified by this event. To estimate the contribution of these events to the code latency, divide them by the cycles at the same granularity. To estimate the overall impact, start with the total cycles due to these issues and if significant continue to search for the exact reason using the sub events.

Total cycles spent in the specified scenarios:

Flags Merge micro-op ratio:

```
%FLAGS.MERGE.UOP =
    100 * PARTIAL_RAT_STALLS.FLAGS_MERGE_UOP_CYCLES /
    CPU_CLK_UNHALTED.THREAD;
```

Slow LEA instructions allocated:

```
%SLOW.LEA.WINDOW =
    100 * PARTIAL_RAT_STALLS.SLOW_LEA_WINDOW /
    CPU_CLK_UNHALTED.THREAD;
```

B.5.5.2 Assists

Assists usually involve the microcode sequencer that helps handle the assist. Determining the number of cycles where microcode is generated from the microcode sequencer is often a good methodology to determine the total cost of the assist. If the overall cost of assists are high, a breakdown of assists into specific types will be useful.

Estimating the total cost of assists using microcode sequencer cycles:

```
%ASSISTS.COST =
    100 * IDQ.MS_CYCLES / CPU_CLK_UNHALTED.THREAD;
```

Floating-point assists:

Denormal inputs for X87 instructions require an FP assist, potentially costing hundreds of cycles.

```
%FP.ASSISTS =
    100 * FP_ASSIST.ANY / INST_RETIRED.ANY;
```

Transitions between Intel SSE and Intel AVX:

The transitions between SSE and AVX code are explained in detail in Section 15.3.1. The typical cost is about 75 cycles.

```
%AVX2SSE.TRANSITION.COST =
    75 * OTHER_ASSISTS.AVX_TO_SSE / CPU_CLK_UNHALTED.THREAD;
%SSE2AVX.TRANSITION.COST =
    75 * OTHER_ASSISTS.SSE_TO_AVX / CPU_CLK_UNHALTED.THREAD;
```

32-byte AVX store instructions that span two pages require an assist that costs roughly 150 cycles. A large amount of microcode tagged to the IP after a 32-byte AVX store is a good sign that an assist has occurred.

```
%AVX.STORE.ASSIST.COST =
    150 * OTHER_ASSISTS.AVX_STORE / CPU_CLK_UNHALTED.THREAD;
```

B.5.6 Bad Speculation

This section discusses mispredicted branch instructions resulting in a pipeline flush.

B.5.6.1 Branch Mispredicts

The largest challenge with mispredicted branches is finding the branch which caused them. Branch mispredictions incur penalty of about 20 cycles. The cost varies based upon the misprediction, and whether the correct path is found in the Decoded ICache or in the legacy decode pipeline.

Required Events:

BR_MISP_RETIRED.ALL_BRANCHES_PS is a precise event that counts branches that incorrectly predicted the branch target. Since this is a precise event that skids to the next instruction, it tags to the first instruction in the correct path after the branch misprediction. This study can be performed at the process, module, function or instruction granularity.

Usages of Events:

Use the following ratio to estimate the cost of mispredicted branches:

```
%BR.MISP.COST =
    20 * BR_MISP_RETIRED.ALL_BRANCHES_PS / CPU_CLK_UNHALTED.THREAD;
```

B.5.7 Frontend Stalls

Stalls in the **Frontend** should not be investigated unless the analysis in Section B.5.2 showed at least 30% of a granularity being bound in the front end. This section explains the main issues that can cause delays in the front end of the pipeline. Events detected in the front end have unpredictable skid. Therefore do not try and associate the penalty at the IP level. Stay at the function, module, and process level for these events.

B.5.7.1 Understanding the Micro-op Delivery Rate

Usages of Counters

The event IDQ_UOPS_NOT_DELIVERED counts when the maximum of four micro-ops are not delivered to the rename stage, while it is requesting micro-ops. When the pipeline is backed up the rename stage

does not request any further micro-ops from the front end. The diagram above shows how this event tracks micro-ops between the micro-op queue and the rename stage.

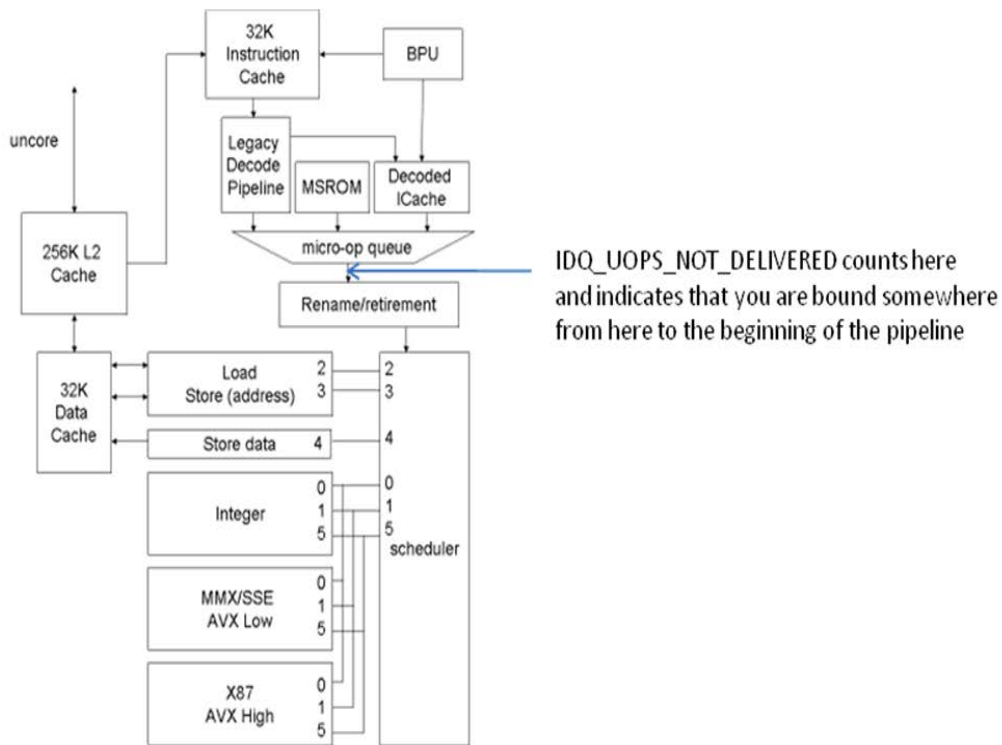

You can use the IDQ_UOPS_NOT_DELIVERED event to breakdown the distribution of cycles when 0, 1, 2, 3 micro-ops are delivered from the front end.

Percentage of cycles the front end is effective, or execution is back end bound:

$$\%FE.DELIVERING = \frac{100 * (CPU_CLK_UNHALTED.THREAD - IDQ_UOPS_NOT_DELIVERED.CYCLES_LE_3_UOP_DELIV.CORE)}{CPU_CLK_UNHALTED.THREAD};$$

Percentage of cycles the front end is delivering three micro-ops per cycle:

$$\%FE.DELIVER.3UOPS = \frac{100 * (IDQ_UOPS_NOT_DELIVERED.CYCLES_LE_3_UOP_DELIV.CORE - IDQ_UOPS_NOT_DELIVERED.CYCLES_LE_2_UOP_DELIV.CORE)}{CPU_CLK_UNHALTED.THREAD};$$

Percentage of cycles the front end is delivering two micro-ops per cycle:

$$\%FE.DELIVER.2UOPS = \frac{100 * (IDQ_UOPS_NOT_DELIVERED.CYCLES_LE_2_UOP_DELIV.CORE - IDQ_UOPS_NOT_DELIVERED.CYCLES_LE_1_UOP_DELIV.CORE)}{CPU_CLK_UNHALTED.THREAD};$$

Percentage of cycles the front end is delivering one micro-ops per cycle:

$$\%FE.DELIVER.1UOPS = \frac{100 * (IDQ_UOPS_NOT_DELIVERED.CYCLES_LE_1_UOP_DELIV.CORE - IDQ_UOPS_NOT_DELIVERED.CYCLES_0_UOPS_DELIV.CORE)}{CPU_CLK_UNHALTED.THREAD};$$

Percentage of cycles the front end is delivering zero micro-ops per cycle:

$$\%FE.DELIVER.0UOPS = \frac{100 * (IDQ_UOPS_NOT_DELIVERED.CYCLES_0_UOPS_DELIV.CORE)}{CPU_CLK_UNHALTED.THREAD};$$

Average Micro-ops Delivered per Cycle: This ratio assumes that the front end could potentially deliver four micro-ops per cycle when bound in the back end.

$$AVG.uops.per.cycle = \frac{(4 * (\%FE.DELIVERING) + 3 * (\%FE.DELIVER.3UOPS) + 2 * (\%FE.DELIVER.2UOPS) + (\%FE.DELIVER.1UOPS))}{100}$$

Seeing the distribution of the micro-ops being delivered in a cycle is a hint at the front end bottlenecks that might be occurring. Issues such as LCPs and penalties from switching from the decoded ICache to the legacy decode pipeline tend to result in zero micro-ops being delivered for several cycles. Fetch bandwidth issues and decoder stalls result in less than four micro-ops delivered per cycle.

B.5.7.2 Understanding the Sources of the Micro-op Queue

The micro-op queue can get micro-ops from the following sources:

- Decoded ICache.
- Legacy decode pipeline.
- Microcode sequencer (MS).

A typical distribution is approximately 80% of the micro-ops coming from the Decoded ICache, 15% coming from legacy decode pipeline and 5% coming from the microcode sequencer. Excessive micro-ops coming from the legacy decode pipeline can be a warning sign that the Decoded ICache is not working effectively. A large portion of micro-ops coming from the microcode sequencer may be benign, such as complex instructions, or string operations, but can also be due to code assists handling undesired situations like Intel SSE to Intel AVX code transitions.

Description of Counters Required:

IDQ.DSB_UOPS - Micro-ops delivered to the micro-op queue from the Decoded ICache.

IDQ.MITE_UOPS - Micro-ops delivered to the micro-op queue from the legacy decode pipeline.

IDQ.MS_UOPS -Micro-ops delivered from the microcode sequencer.

Usage of Counters:

Percentage of micro-ops coming from Decoded ICache:

$$\%UOPS.DSB = \frac{IDQ.DSB_UOPS}{ALL_IDQ_UOPS};$$

Percentage of micro-ops coming from legacy decoder pipeline:

$$\%UOPS.MITE = \frac{IDQ.MITE_UOPS}{ALL_IDQ_UOPS};$$

Percentage of micro-ops coming from micro-sequencer:

$$\%UOPS.MS = \frac{IDQ.MS_UOPS}{ALL_IDQ_UOPS};$$

$$ALL_IDQ_UOPS = (IDQ.DSB_UOPS + IDQ.MITE_UOPS + IDQ.MS_UOPS);$$

If your application is not bound in the front end then whether micro-ops are coming from the legacy decode pipeline or Decoded ICache is of lesser importance. Excessive micro-ops coming from the microcode sequencer are worth investigating further to see if assists might be a problem.

Cases to investigate are listed below:

- **(%FE_BOUND > 30%) and (%UOPS.DSB < 70%)**
A threshold of 30% defines a "front end bound" case. This threshold may be applicable to many situations, but may also vary somewhat across different workloads.

- Investigate why micro-ops are not coming from the Decoded ICache.
- Investigate issues which can impact the legacy decode pipeline.
- (%FE_BOUND > 30%) and (%UOP_DSB > 70%)
 - Investigate switches from Decoded ICache to legacy decode pipeline since it may be switching to run portions of code that are too small to be effective.
 - Look at the amount of bad speculation, since branch mispredictions still impact FE performance.
 - Determine the average number of micro-ops being delivered per 32-byte chunk hit. If there are many taken branches from one 32-byte chunk into another, it impacts the micro-ops being delivered per cycle.
 - Micro-op delivery from the Decoded ICache may be an issue which is not covered.
- (%FE_BOUND < 20%) and (%UOPS_MS>25%)

A threshold of 20% defines a “front end not bound” case. This threshold may be applicable to many situations, but may also vary somewhat across different workloads.

The following steps can help determine why micro-ops came from the microcode, in order of most common to least common.

 - Long latency instructions - Any instruction over four micro-ops starts the microcode sequencer. Some instructions such as transcendentals can generate many micro-ops from the microcode.
 - String operations - string operations can produce a large amount of microcode. In some cases there are assists which can occur due to string operations such as REP MOVSB with trip count greater than 3, which costs 70+ cycles.
 - Assists - See Section B.5.5.2.

B.5.7.3 The Decoded ICache

The Decoded ICache has many advantages over the legacy decode pipeline. It eliminates many bottlenecks of the legacy decode pipeline such as instructions decoded into more than one micro-op and length changing prefix (LCP) stalls.

A switch to the legacy decode pipeline from the Decoded ICache only occurs when a lookup in the Decoded ICache fails and usually costs anywhere from zero to three cycles in the front end of the pipeline.

Required events:

The Decoded ICache events all have large skids and the exact instruction where they are tagged is usually not the source of the problem so only look for this issue at the process, module and function granularities.

DSB2MITE_SWITCHES.PENALTY_CYCLES - Counts the cycles attributed to the switch from the Decoded ICache to the legacy decode pipeline, excluding cycles when the micro-op queue cannot accept micro-ops because it is back end bound.

DSB2MITE_SWITCHES.COUNT - Counts the number of switches between the Decoded ICache and the legacy decode pipeline.

DSB_FILL.ALL_CANCEL - Counts when fills to the Decoded ICache are canceled.

DSB_FILL.EXCEED_DSB_LINES- Counts when a fill is canceled because the allocated lines for Decoded ICache has exceeded three for the 32-byte chunk.

Usage of Events:

Since these studies involve front end events, do not try to tag the event to a specific instruction.

Determining cost of switches from the Decoded ICache to the legacy decode pipeline.

%DSB2MITE.SWITCH.COST =

$$100 * \text{DSB2MITE_SWITCHES.PENALTY_CYCLES} / \text{CPU_CLK_UNHALTED.THREAD};$$

Determining the average cost per Decoded ICache switch to the legacy front end:

```
AVG.DSB2MITE.SWITCH.COST =
    DSB2MITE_SWITCHES.PENALTY_CYCLES / DSB2MITE_SWITCHES.COUNT;
```

Determining causes of misses in the decoded ICache

There are no partial hits in the Decoded ICache. If any micro-op that is part of that lookup on the 32-byte chunk is missing, a Decoded ICache miss occurs on all micro-ops for that transaction.

There are three primary reasons for missing micro-ops in the Decoded ICache:

- Portions of a 32-byte chunk of code were not able to fit within three ways of the Decoded ICache.
- A frequently run portion of your code section is too large for the Decoded ICache. This case is more common on server applications since client applications tend to have a smaller set of code which is “hot”.
- The Decoded ICache is getting flushed for example when an ITLB entry is evicted.

To determine if a portion of the 32-byte code is unable to fit into three lines within the Decoded ICache use the DSB_FILL.EXCEED_DSB_LINES event at the process, module or function granularities

```
%DSB.EXCEED.WAY.LIMIT =
    100 * DSB_FILL.EXCEED_DSB_LINES / DSB_FILL.ALL_CANCEL;
```

B.5.7.4 Issues in the Legacy Decode Pipeline

If a large percentage of the micro-ops going to the micro-op queue are being delivered from the legacy decode pipeline, you should check to see if there are bottlenecks impacting that stage. The most common bottlenecks in the legacy decode pipeline are:

- Fetch not providing enough instructions.
This happens when hot code is poorly aligned. For example if the hot code being fetched to be run is on the 15th byte, then only one byte is fetched.
- Length changing prefix stalls in the instruction length decoder.
Instructions that are decoded into two to four micro-ops may introduce a bubble in the decoder throughput. If the instruction queue, preceding the decoders, becomes full, this indicates that these instructions may cause a penalty.

```
%ILD.STALL.COST =
    100 * ILD_STALL.LCP * 3 / CPU_CLK_UNHALTED.THREAD;
```

B.5.7.5 Instruction Cache

Applications with large hot code sections tend to run into many issues with the instruction cache. This is more typical in server applications.

Required events:

ICACHE.MISSES - Counts the number of instruction byte fetches that miss the ICache

Usage of events:

To determine whether ICache misses are causing the issue, compare them to the instructions retired event count, using the same granularity (process, model, or function). Anything over 1% of instructions retired can be a significant issue.

```
ICACHE.PER.INST.RET =
    ICACHE.MISSES / INST_RETIRED.ANY;
```

If ICache misses are causing a significant problem, try to reduce the size of your hot code section, using the profile guided optimizations. Most compilers have options for text reordering which helps reduce the number of pages and, to a lesser extent, the number of pages your application is covering.

If the application makes significant use of macros, try to either convert them to functions, or use intelligent linking to eliminate repeated code.

B.6 USING PERFORMANCE EVENTS OF INTEL® CORE™ SOLO AND INTEL® CORE™ DUO PROCESSORS

There are performance events specific to the microarchitecture of Intel Core Solo and Intel Core Duo processors. Lists of available performance-monitoring events can be found at:

<https://perfmon-events.intel.com/>.

B.6.1 Understanding the Results in a Performance Counter

Each performance event detects a well-defined microarchitectural condition occurring in the core while the core is active. A core is active when:

- It's running code (excluding the halt instruction).
- It's being snooped by the other core or a logical processor on the platform. This can also happen when the core is halted.

Some microarchitectural conditions are applicable to a sub-system shared by more than one core and some performance events provide an event mask (or unit mask) that allows qualification at the physical processor boundary or at bus agent boundary.

Some events allow qualifications that permit the counting of microarchitectural conditions associated with a particular core versus counts from all cores in a physical processor (see L2 and bus related events at: <https://perfmon-events.intel.com/>).

When a multi-threaded workload does not use all cores continuously, a performance counter counting a core-specific condition may progress to some extent on the halted core and stop progressing or a unit mask may be qualified to continue counting occurrences of the condition attributed to either processor core. Typically, one can adjust the highest two bits (bits 15:14 of the IA32_PERFEVTSELx MSR) in the unit mask field to distinguish such asymmetry (See Chapter 18, "Debug, Branch Profile, TSC, and Intel® Resource Director Technology (Intel® RDT) Features," of the *Intel® 64 and IA-32 Architectures Software Developer's Manual, Volume 3B*).

There are three cycle-counting events which will not progress on a halted core, even if the halted core is being snooped. These are: Unhalted core cycles, Unhalted reference cycles, and Unhalted bus cycles. All three events are detected for the unit selected by event 3CH.

Some events detect microarchitectural conditions but are limited in their ability to identify the originating core or physical processor. For example, bus_drdy_clocks may be programmed with a unit mask of 20H to include all agents on a bus. In this case, the performance counter in each core will report nearly identical values. Performance tools interpreting counts must take into account that it is only necessary to equate bus activity with the event count from one core (and not use not the sum from each core).

The above is also applicable when the core-specificity sub field (bits 15:14 of IA32_PERFEVTSELx MSR) within an event mask is programmed with 11B. The result of reported by performance counter on each core will be nearly identical.

B.6.2 Ratio Interpretation

Ratios of two events are useful for analyzing various characteristics of a workload. It may be possible to acquire such ratios at multiple granularities, for example: (1) per-application thread, (2) per logical processor, (3) per core, and (4) per physical processor.

The first ratio is most useful from a software development perspective, but requires multi-threaded applications to manage processor affinity explicitly for each application thread. The other options provide insights on hardware utilization.

In general, collect measurements (for all events in a ratio) in the same run. This should be done because:

- If measuring ratios for a multi-threaded workload, getting results for all events in the same run enables you to understand which event counter values belongs to each thread.

- Some events, such as writebacks, may have non-deterministic behavior for different runs. In such a case, only measurements collected in the same run yield meaningful ratio values.

B.6.3 Notes on Selected Events

This section provides event-specific notes for interpreting performance events listed at: <https://perfmon-events.intel.com/>.

- **L2_Reject_Cycles, event number 30H** — This event counts the cycles during which the L2 cache rejected new access requests.
- **L2_No_Request_Cycles, event number 32H** — This event counts cycles during which no requests from the L1 or prefetches to the L2 cache were issued.
- **Unhalted_Core_Cycles, event number 3C, unit mask 00H** — This event counts the smallest unit of time recognized by an active core.

In many operating systems, the idle task is implemented using HLT instruction. In such operating systems, clock ticks for the idle task are not counted. A transition due to Enhanced Intel SpeedStep Technology may change the operating frequency of a core. Therefore, using this event to initiate time-based sampling can create artifacts.

- **Unhalted_Ref_Cycles, event number 3C, unit mask 01H** — This event guarantees a uniform interval for each cycle being counted. Specifically, counts increment at bus clock cycles while the core is active. The cycles can be converted to core clock domain by multiplying the bus ratio which sets the core clock frequency.
- **Serial_Execution_Cycles, event number 3C, unit mask 02H** — This event counts the bus cycles during which the core is actively executing code (non-halted) while the other core in the physical processor is halted.
- **L1_Pref_Req, event number 4FH, unit mask 00H** — This event counts the number of times the Data Cache Unit (DCU) requests to prefetch a data cache line from the L2 cache. Requests can be rejected when the L2 cache is busy. Rejected requests are re-submitted.
- **DCU_Snoop_to_Share, event number 78H, unit mask 01H** — This event counts the number of times the DCU is snooped for a cache line needed by the other core. The cache line is missing in the L1 instruction cache or data cache of the other core; or it is set for read-only, when the other core wants to write to it. These snoops are done through the DCU store port. Frequent DCU snoops may conflict with stores to the DCU, and this may increase store latency and impact performance.
- **Bus_Not_In_Use, event number 7DH, unit mask 00H** — This event counts the number of bus cycles for which the core does not have a transaction waiting for completion on the bus.
- **Bus_Snoops, event number 77H, unit mask 00H** — This event counts the number of CLEAN, HIT, or HITM responses to external snoops detected on the bus.

In a single-processor system, CLEAN and HIT responses are not likely to happen. In a multiprocessor system this event indicates an L2 miss in one processor that did not find the missed data on other processors.

In a single-processor system, an HITM response indicates that an L1 miss (instruction or data) found the missed cache line in the other core in a modified state. In a multiprocessor system, this event also indicates that an L1 miss (instruction or data) found the missed cache line in another core in a modified state.

B.7 DRILL-DOWN TECHNIQUES FOR PERFORMANCE ANALYSIS

Software performance intertwines code and microarchitectural characteristics of the processor. Performance monitoring events provide insights to these interactions. Each microarchitecture often provides a large set of performance events that target different sub-systems within the microarchitecture. Having a methodical approach to select key performance events will likely improve a programmer's understanding of the performance bottlenecks and improve the efficiency of code-tuning effort.

Recent generations of Intel 64 and IA-32 processors feature microarchitectures using an out-of-order execution engine. They are also accompanied by an in-order front end and retirement logic that enforces program order. Superscalar hardware, buffering and speculative execution often complicates the interpretation of performance events and software-visible performance bottlenecks.

This section discusses a methodology of using performance events to drill down on likely areas of performance bottleneck. By narrowed down to a small set of performance events, the programmer can take advantage of Intel VTune Performance Analyzer to correlate performance bottlenecks with source code locations and apply coding recommendations discussed in Chapter 3 through Chapter 11. Although the general principles of our method can be applied to different microarchitectures, this section will use performance events available in processors based on Intel Core microarchitecture for simplicity.

Performance tuning usually centers around reducing the time it takes to complete a well-defined workload. Performance events can be used to measure the elapsed time between the start and end of a workload. Thus, reducing elapsed time of completing a workload is equivalent to reducing measured processor cycles.

The drill-down methodology can be summarized as four phases of performance event measurements to help characterize interactions of the code with key pipe stages or sub-systems of the microarchitecture. The relation of the performance event drill-down methodology to the software tuning feedback loop is illustrated in Figure B-16.

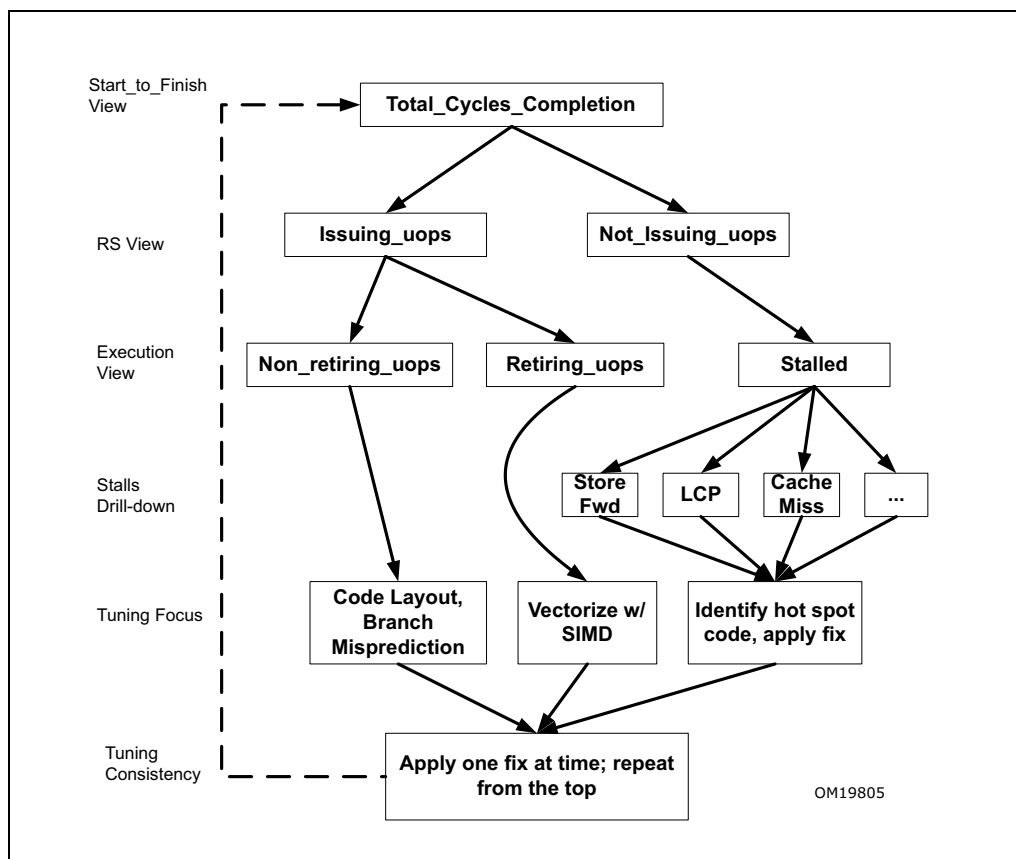

Figure B-16. Performance Events Drill-Down and Software Tuning Feedback Loop

Typically, the logic in performance monitoring hardware measures microarchitectural conditions that varies across different counting domains, ranging from cycles, micro-ops, address references, instances, etc. The drill-down methodology attempts to provide an intuitive, cycle-based view across different phases by making suitable approximations that are described below:

- **Total cycle measurement** — This is the start to finish view of total number of cycle to complete the workload of interest. In typical performance tuning situations, the metric `Total_cycles` can be measured by the event `CPU_CLK_UNHALTED.CORE`. See: <https://perfmon-events.intel.com/>).
- **Cycle composition at issue port** — The reservation station (RS) dispatches micro-ops for execution so that the program can make forward progress. Hence the metric `Total_cycles` can be decomposed as consisting of two exclusive components: `Cycles_not_issuing_uops` representing cycles that the RS is not issuing micro-ops for execution, and `Cycles_issuing_uops` cycles that the RS is issuing micro-ops for execution. The latter component includes micro-ops in the architected code path or in the speculative code path.
- **Cycle composition of OOO execution** — The out-of-order engine provides multiple execution units that can execute micro-ops in parallel. If one execution unit stalls, it does not necessarily imply the program execution is stalled. Our methodology attempts to construct a cycle-composition view that approximates the progress of program execution. The three relevant metrics are: `Cycles_stalled`, `Cycles_not_retiring_uops`, and `Cycles_retiring_uops`.
- **Execution stall analysis** — From the cycle compositions of overall program execution, the programmer can narrow down the selection of performance events to further pin-point unproductive interaction between the workload and a micro-architectural sub-system.

When cycles lost to a stalled microarchitectural sub-system, or to unproductive speculative execution are identified, the programmer can use VTune Analyzer to correlate each significant performance impact to source code location. If the performance impact of stalls or misprediction is insignificant, VTune can also identify the source locations of hot functions, so the programmer can evaluate the benefits of vectorization on those hot functions.

B.7.1 Cycle Composition at Issue Port

Recent processor microarchitectures employ out-of-order engines that execute streams of micro-ops natively, while decoding program instructions into micro-ops in its front end. The metric `Total_cycles` alone, is opaque with respect to decomposing cycles that are productive or non-productive for program execution. To establish a consistent cycle-based decomposition, construct two metrics that can be measured using performance events available in processors based on Intel Core microarchitecture. These are:

- **Cycles_not_issuing_uops** — This can be measured by the event `RS_UOPS_DISPATCHED`, setting the `INV` bit and specifying a counter mask (`CMASK`) value of 1 in the target performance event select (`IA32_PERFVTSELx`) MSR (See Chapter 19 of the *Intel® 64 and IA-32 Architectures Software Developer's Manual, Volume 3B*). In VTune Analyzer, the special values for `CMASK` and `INV` is already configured for the VTune event name `RS_UOPS_DISPATCHED.CYCLES_NONE`.
- **Cycles_issuing_uops** — This can be measured using the event `RS_UOPS_DISPATCHED`, clear the `INV` bit and specifying a counter mask (`CMASK`) value of 1 in the target performance event select MSR

Note the cycle decomposition view here is approximate in nature; it does not distinguish specificities, such as whether the RS is full or empty, transient situations of RS being empty but some in-flight uops is getting retired.

B.7.2 Cycle Composition of OOO Execution

In an OOO engine, part of making forward progress of the program. But speculative execution of micro-ops in the shadow of mispredicted code path represent unproductive work that consumes execution resources and execution bandwidth.

`Cycles_not_issuing_uops`, by definition, represents the cycles that the OOO engine is stalled (`Cycles_stalled`). As an approximation, this can be interpreted as the cycles that the program is not making forward progress.

The micro-ops that are issued for execution do not necessarily end in retirement. Those micro-ops that do not reach retirement do not help forward progress of program execution. Hence, a further approximation is made in the formalism of decomposition of `Cycles_issuing_uops` into:

- **Cycles_non_retiring_uops** — Although there isn't a direct event to measure the cycles associated with non-retiring micro-ops, derive this metric from available performance events, and several assumptions:
 - A constant issue rate of micro-ops flowing through the issue port. Thus, define: `uops_rate` = `Dispatch_uops/Cycles_issuing_uops`, where `Dispatch_uops` can be measured with `RS_UOPS_DISPATCHED`, clearing the `INV` bit and the `CMASK`.
 - Approximate the number of non-productive, non-retiring micro-ops by `[non_productive_uops = Dispatch_uops - executed_retired_uops]`, where `executed_retired_uops` represent productive micro-ops contributing towards forward progress that consumed execution bandwidth.
 - The `executed_retired_uops` can be approximated by the sum of two contributions: `num_retired_uops` (measured by the event `UOPS_RETIRED.ANY`) and `num_fused_uops` (measured by the event `UOPS_RETIRED.FUSED`).
 Thus, `Cycles_non_retiring_uops = non_productive_uops / uops_rate`.
- **Cycles_retiring_uops** — This can be derived from `Cycles_retiring_uops = num_retired_uops / uops_rate`.

The cycle-decomposition methodology here does not distinguish situations where productive uops and non-productive micro-ops may be dispatched in the same cycle into the OOO engine. This approximation may be reasonable because heuristically high contribution of non-retiring uops likely correlates to situations of congestions in the OOO engine and subsequently cause the program to stall.

Evaluations of these three components: `Cycles_non_retiring_uops`, `Cycles_stalled`, `Cycles_retiring_uops`, relative to the `Total_cycles`, can help steer tuning effort in the following directions:

- If the contribution from `Cycles_non_retiring_uops` is high, focusing on code layout and reducing branch mispredictions will be important.
- If both the contributions from `Cycles_non_retiring_uops` and `Cycles_stalled` are insignificant, the focus for performance tuning should be directed to vectorization or other techniques to improve retirement throughput of hot functions.
- If the contributions from `Cycles_stalled` is high, additional drill-down may be necessary to locate bottlenecks that lies deeper in the microarchitecture pipeline.

B.7.3 Drill-Down on Performance Stalls

In some situations, it may be useful to evaluate cycles lost to stalls associated with various stress points in the microarchitecture and sum up the contributions from each candidate stress points. This approach implies a very gross simplification and introduce complications that may be difficult to reconcile with the superscalar nature and buffering in an OOO engine.

Due to the variations of counting domains associated with different performance events, cycle-based estimation of performance impact at each stress point may carry different degree of errors due to over-estimation of exposures or under-estimations.

Over-estimation is likely to occur when overall performance impact for a given cause is estimated by multiplying the per-instance-cost to an event count that measures the number of occurrences of that microarchitectural condition. Consequently, the sum of multiple contributions of lost cycles due to different stress points may exceed the more accurate metric `Cycles_stalled`.

However an approach that sums up lost cycles associated with individual stress point may still be beneficial as an iterative indicator to measure the effectiveness of code tuning loop effort when tuning code to fix the performance impact of each stress point. The remaining of this sub-section will discuss a few common causes of performance bottlenecks that can be counted by performance events and fixed by following coding recommendations described in this manual.

The following items discuss several common stress points of the microarchitecture:

- **L2 Miss Impact** — An L2 load miss may expose the full latency of memory sub-system. The latency of accessing system memory varies with different chipset, generally on the order of more than a hundred cycles. Server chipset tend to exhibit longer latency than desktop chipsets. The number L2 cache miss references can be measured by MEM_LOAD_RETIRED.L2_LINE_MISS.

An estimation of overall L2 miss impact by multiplying system memory latency with the number of L2 misses ignores the OOO engine's ability to handle multiple outstanding load misses. Multiplication of latency and number of L2 misses imply each L2 miss occur serially.

To improve the accuracy of estimating L2 miss impact, an alternative technique should also be considered, using the event BUS_REQUEST_OUTSTANDING with a CMASK value of 1. This alternative technique effectively measures the cycles that the OOO engine is waiting for data from the outstanding bus read requests. It can overcome the over-estimation of multiplying memory latency with the number of L2 misses.

- **L2 Hit Impact** — Memory accesses from L2 will incur the cost of L2 latency (See Table E-23). The number cache line references of L2 hit can be measured by the difference between two events: MEM_LOAD_RETIRED.L1D_LINE_MISS - MEM_LOAD_RETIRED.L2_LINE_MISS.

An estimation of overall L2 hit impact by multiplying the L2 hit latency with the number of L2 hit references ignores the OOO engine's ability to handle multiple outstanding load misses.

- **L1 DTLB Miss Impact** — The cost of a DTLB lookup miss is about 10 cycles. The event MEM_LOAD_RETIRED.DTLB_MISS measures the number of load micro-ops that experienced a DTLB miss.
- **LCP Impact** — The overall impact of LCP stalls can be directly measured by the event ILD_STALLS. The event ILD_STALLS measures the number of times the slow decoder was triggered, the cost of each instance is 6 cycles
- **Store forwarding stall Impact** — When a store forwarding situation does not meet address or size requirements imposed by hardware, a stall occurs. The delay varies for different store forwarding stall situations. Consequently, there are several performance events that provide fine-grain specificity to detect different store-forwarding stall conditions. These include:
 - A load blocked by preceding store to unknown address: This situation can be measure by the event Load_Blocks.Sta. The per-instance cost is about 5 cycles.
 - Load partially overlaps with proceeding store or 4-KByte aliased address between a load and a proceeding store: these two situations can be measured by the event Load_Blocks.Overlap_store.
 - A load spanning across cache line boundary: This can be measured by Load_Blocks.Until_Retire. The per-instance cost is about 20 cycles.

B.8 EVENT RATIOS FOR INTEL CORE MICROARCHITECTURE

Appendix B.8 provides examples of using performance events to quickly diagnose performance bottlenecks. This section provides additional information on using performance events to evaluate metrics that can help in wide range of performance analysis, workload characterization, and performance tuning. Note that many performance event names in the Intel Core microarchitecture carry the format of XXXX.YYY. This notation derives from the general convention that XXXX typically corresponds to a unique event select code in the performance event select register (IA32_PERFVSELx), while YYY corresponds to a unique sub-event mask that uniquely defines a specific microarchitectural condition (See Chapter 19 of the *Intel[®] 64 and IA-32 Architectures Software Developer's Manual, Volume 3B* and event lists found at: <https://perfmon-events.intel.com/>).

B.8.1 Clocks Per Instructions Retired Ratio (CPI)

1. Clocks Per Instruction Retired Ratio (CPI): CPU_CLK_UNHALTED.CORE / INST_RETIRED.ANY.

The Intel Core microarchitecture is capable of reaching CPI as low as 0.25 in ideal situations. But most of the code has higher CPI The greater value of CPI for a given workload indicate it has more opportunity for

code tuning to improve performance. The CPI is an overall metric, it does not provide specificity of what microarchitectural sub-system may be contributing to a high CPI value.

The following subsections defines a list of event ratios that are useful to characterize interactions with the front end, execution, and memory.

B.8.2 Front End Ratios

2. RS Full Ratio: $\text{RESOURCE_STALLS.RS_FULL} / \text{CPU_CLK_UNHALTED.CORE} * 100$
3. ROB Full Ratio: $\text{RESOURCE_STALLS.ROB_FULL} / \text{CPU_CLK_UNHALTED.CORE} * 100$
4. Load or Store Buffer Full Ratio: $\text{RESOURCE_STALLS.LD_ST} / \text{CPU_CLK_UNHALTED.CORE} * 100$

When there is a low value for the ROB Full Ratio, RS Full Ratio, and Load Store Buffer Full Ratio, and high CPI it is likely that the front end cannot provide instructions and micro-ops at a rate high enough to fill the buffers in the out-of-order engine, and therefore it is starved waiting for micro-ops to execute. In this case check further for other front end performance issues.

B.8.2.1 Code Locality

5. Instruction Fetch Stall: $\text{CYCLES_L1I_MEM_STALLED} / \text{CPU_CLK_UNHALTED.CORE} * 100$

The Instruction Fetch Stall ratio is the percentage of cycles during which the Instruction Fetch Unit (IFU) cannot provide cache lines for decoding due to cache and Instruction TLB (ITLB) misses. A high value for this ratio indicates potential opportunities to improve performance by reducing the working set size of code pages and instructions being executed, hence improving code locality.

6. ITLB Miss Rate: $\text{ITLB_MISS_RETIRED} / \text{INST_RETIRED.ANY}$

A high ITLB Miss Rate indicates that the executed code is spread over too many pages and cause many Instructions TLB misses. Retired ITLB misses cause the pipeline to naturally drain, while the miss stalls fetching of more instructions.

7. L1 Instruction Cache Miss Rate: $\text{L1I_MISSES} / \text{INST_RETIRED.ANY}$

A high value for L1 Instruction Cache Miss Rate indicates that the code working set is bigger than the L1 instruction cache. Reducing the code working set may improve performance.

8. L2 Instruction Cache Line Miss Rate: $\text{L2_IFETCH.SELF.I_STATE} / \text{INST_RETIRED.ANY}$

L2 Instruction Cache Line Miss Rate higher than zero indicates instruction cache line misses from the L2 cache may have a noticeable performance impact of program performance.

B.8.2.2 Branching and Front End

9. BACLEAR Performance Impact: $7 * \text{BACLEARS} / \text{CPU_CLK_UNHALTED.CORE}$

A high value for BACLEAR Performance Impact ratio usually indicates that the code has many branches such that they cannot be consumed by the Branch Prediction Unit.

10. Taken Branch Bubble: $(\text{BR_TKN_BUBBLE_1} + \text{BR_TKN_BUBBLE_2}) / \text{CPU_CLK_UNHALTED.CORE}$

A high value for Taken Branch Bubble ratio indicates that the code contains many taken branches coming one after the other and cause bubbles in the front end. This may affect performance only if it is not covered by execution latencies and stalls later in the pipe.

B.8.2.3 Stack Pointer Tracker

11. ESP Synchronization: $\text{ESP.SYNCH} / \text{ESP.ADDITIONS}$

The ESP Synchronization ratio calculates the ratio of ESP explicit use (for example by load or store instruction) and implicit uses (for example by PUSH or POP instruction). The expected ratio value is 0.2 or lower. If the ratio is higher, consider rearranging your code to avoid ESP synchronization events.

B.8.2.4 Macro-fusion

12. Macro-Fusion: $\text{UOPS_RETIRED.MACRO_FUSION} / \text{INST_RETIRED.ANY}$

The Macro-Fusion ratio calculates how many of the retired instructions were fused to a single micro-op. You may find this ratio is high for a 32-bit binary executable but significantly lower for the equivalent 64-bit binary, and the 64-bit binary performs slower than the 32-bit binary. A possible reason is the 32-bit binary benefited from macro-fusion significantly.

B.8.2.5 Length Changing Prefix (LCP) Stalls

13. LCP Delays Detected: $\text{ILD_STALL} / \text{CPU_CLK_UNHALTED.CORE}$

A high value of the LCP Delays Detected ratio indicates that many Length Changing Prefix (LCP) delays occur in the measured code.

B.8.2.6 Self Modifying Code Detection

14. Self Modifying Code Clear Performance Impact: $\text{MACHINE_NUKES.SMC} * 150 / \text{CPU_CLK_UNHALTED.CORE} * 100$

A program that writes into code sections and shortly afterwards executes the generated code may incur severe penalties. Self Modifying Code Performance Impact estimates the percentage of cycles that the program spends on self-modifying code penalties.

B.8.3 Branch Prediction Ratios

Appendix B.8.2.2 discusses branching that impacts the front end performance. This section describes event ratios that are commonly used to characterize branch mispredictions.

B.8.3.1 Branch Mispredictions

15. Branch Misprediction Performance Impact: $\text{RESOURCE_STALLS.BR_MISS_CLEAR} / \text{CPU_CLK_UNHALTED.CORE} * 100$

With the Branch Misprediction Performance Impact, you can tell the percentage of cycles that the processor spends in recovering from branch mispredictions.

16. Branch Misprediction per Micro-Op Retired: $\text{BR_INST_RETIRED.MISPRED} / \text{UOPS_RETIRED.ANY}$

The ratio Branch Misprediction per Micro-Op Retired indicates if the code suffers from many branch mispredictions. In this case, improving the predictability of branches can have a noticeable impact on the performance of your code.

In addition, the performance impact of each branch misprediction might be high. This happens if the code prior to the mispredicted branch has high CPI, such as cache misses, which cannot be parallelized with following code due to the branch misprediction. Reducing the CPI of this code will reduce the misprediction performance impact. See other ratios to identify these cases.

You can use the precise event `BR_INST_RETIRED.MISPRED` to detect the actual targets of the mispredicted branches. This may help you to identify the mispredicted branch.

B.8.3.2 Virtual Tables and Indirect Calls

17. Virtual Table Usage: $\text{BR_IND_CALL_EXEC} / \text{INST_RETIRED.ANY}$

A high value for the ratio Virtual Table Usage indicates that the code includes many indirect calls. The destination address of an indirect call is hard to predict.

18. Virtual Table Misuse: $\text{BR_CALL_MISSP_EXEC} / \text{BR_INST_RETIRED.MISPRED}$

A high value of Branch Misprediction Performance Impact ratio (Ratio 15) together with high Virtual Table Misuse ratio indicate that significant time is spent due to mispredicted indirect function calls.

In addition to explicit use of function pointers in C code, indirect calls are used for implementing inheritance, abstract classes, and virtual methods in C++.

B.8.3.3 Mispredicted Returns

19. Mispredicted Return Instruction Rate: $BR_RET_MISSP_EXEC / BR_RET_EXEC$

The processor has a special mechanism that tracks CALL-RETURN pairs. The processor assumes that every CALL instruction has a matching RETURN instruction. If a RETURN instruction restores a return address, which is not the one stored during the matching CALL, the code incurs a misprediction penalty.

B.8.4 Execution Ratios

This section covers event ratios that can provide insights to the interactions of micro-ops with RS, ROB, execution units, and so forth.

B.8.4.1 Resource Stalls

A high value for the RS Full Ratio (Ratio 2) indicates that the Reservation Station (RS) often gets full with micro-ops due to long dependency chains. The micro-ops that get into the RS cannot execute because they wait for their operands to be computed by previous micro-ops, or they wait for a free execution unit to be executed. This prevents exploiting the parallelism provided by the multiple execution units.

A high value for the ROB Full Ratio (Ratio 3) indicates that the reorder buffer (ROB) often gets full with micro-ops. This usually implies on long latency operations, such as L2 cache demand misses.

B.8.4.2 ROB Read Port Stalls

20. ROB Read Port Stall Rate: $RAT_STALLS.ROB_READ_PORT / CPU_CLK_UNHALTED.CORE$

The ratio ROB Read Port Stall Rate identifies ROB read port stalls. However it should be used only if the number of resource stalls, as indicated by Resource Stall Ratio, is low.

B.8.4.3 Partial Register Stalls

21. Partial Register Stalls Ratio: $RAT_STALLS.PARTIAL_CYCLES / CPU_CLK_UNHALTED.CORE * 100$

Frequent accesses to registers that cause partial stalls increase access latency and decrease performance. Partial Register Stalls Ratio is the percentage of cycles when partial stalls occur.

B.8.4.4 Partial Flag Stalls

22. Partial Flag Stalls Ratio: $RAT_STALLS.FLAGS / CPU_CLK_UNHALTED.CORE$

Partial flag stalls have high penalty and they can be easily avoided. However, in some cases, Partial Flag Stalls Ratio might be high although there are no real flag stalls. There are a few instructions that partially modify the RFLAGS register and may cause partial flag stalls. The most popular are the shift instructions (SAR, SAL, SHR, and SHL) and the INC and DEC instructions.

B.8.4.5 Bypass Between Execution Domains

23. Delayed Bypass to FP Operation Rate: $DELAYED_BYPASS.FP / CPU_CLK_UNHALTED.CORE$

24. Delayed Bypass to SIMD Operation Rate: $DELAYED_BYPASS.SIMD / CPU_CLK_UNHALTED.CORE$

25. Delayed Bypass to Load Operation Rate: $DELAYED_BYPASS.LOAD / CPU_CLK_UNHALTED.CORE$

Domain bypass adds one cycle to instruction latency. To identify frequent domain bypasses in the code you can use the above ratios.

B.8.4.6 Floating-Point Performance Ratios

26. Floating-Point Instructions Ratio: $X87_OPS_RETIRED.ANY / INST_RETIRED.ANY * 100$

Significant floating-point activity indicates that specialized optimizations for floating-point algorithms may be applicable.

27. FP Assist Performance Impact: $FP_ASSIST * 80 / CPU_CLK_UNHALTED.CORE * 100$

Floating-Point assist is activated for non-regular FP values like denormals and NaNs. FP assist is extremely slow compared to regular FP execution. Different assists incur different penalties. FP Assist Performance Impact estimates the overall impact.

28. Divider Busy: $IDLE_DURING_DIV / CPU_CLK_UNHALTED.CORE * 100$

A high value for the Divider Busy ratio indicates that the divider is busy and no other execution unit or load operation is in progress for many cycles. Using this ratio ignores L1 data cache misses and L2 cache misses that can be executed in parallel and hide the divider penalty.

29. Floating-Point Control Word Stall Ratio: $RESOURCE_STALLS.FPCW / CPU_CLK_UNHALTED.CORE * 100$

Frequent modifications to the Floating-Point Control Word (FPCW) might significantly decrease performance. The main reason for changing FPCW is for changing rounding mode when doing FP to integer conversions.

B.8.5 Memory Sub-System - Access Conflicts Ratios

A high value for Load or Store Buffer Full Ratio (Ratio 4) indicates that the load buffer or store buffer are frequently full, hence new micro-ops cannot enter the execution pipeline. This can reduce execution parallelism and decrease performance.

30. Load Rate: $L1D_CACHE_LD.MESI / CPU_CLK_UNHALTED.CORE$

One memory read operation can be served by a core each cycle. A high "Load Rate" indicates that execution may be bound by memory read operations.

31. Store Order Block: $STORE_BLOCK.ORDER / CPU_CLK_UNHALTED.CORE * 100$

Store Order Block ratio is the percentage of cycles that store operations, which miss the L2 cache, block committing data of later stores to the memory sub-system. This behavior can further cause the store buffer to fill up (see Ratio 4).

B.8.5.1 Loads Blocked by the L1 Data Cache

32. Loads Blocked by L1 Data Cache Rate: $LOAD_BLOCK.L1D/CPU_CLK_UNHALTED.CORE$

A high value for "Loads Blocked by L1 Data Cache Rate" indicates that load operations are blocked by the L1 data cache due to lack of resources, usually happening as a result of many simultaneous L1 data cache misses.

B.8.5.2 4K Aliasing and Store Forwarding Block Detection

33. Loads Blocked by Overlapping Store Rate: $LOAD_BLOCK.OVERLAP_STORE/CPU_CLK_UNHALTED.CORE$

4K aliasing and store forwarding block are two different scenarios in which loads are blocked by preceding stores due to different reasons. Both scenarios are detected by the same event: $LOAD_BLOCK.OVERLAP_STORE$. A high value for "Loads Blocked by Overlapping Store Rate" indicates that either 4K aliasing or store forwarding block may affect performance.

B.8.5.3 Load Block by Preceding Stores

34. Loads Blocked by Unknown Store Address Rate: $LOAD_BLOCK.STA / CPU_CLK_UNHALTED.CORE$

A high value for “Loads Blocked by Unknown Store Address Rate” indicates that loads are frequently blocked by preceding stores with unknown address and implies performance penalty.

35. Loads Blocked by Unknown Store Data Rate: $\text{LOAD_BLOCK.STD} / \text{CPU_CLK_UNHALTED.CORE}$

A high value for “Loads Blocked by Unknown Store Data Rate” indicates that loads are frequently blocked by preceding stores with unknown data and implies performance penalty.

B.8.5.4 Memory Disambiguation

The memory disambiguation feature of Intel Core microarchitecture uses a predictor to allow loads to execute speculatively in the presence of older unknown stores. This eliminates most of the non-required load blocks by stores with an unknown address. The `LOAD_BLOCK.STA` and `MEMORY_DISAMBIGUATION.RESET` events can be used to measure the effectiveness of the feature.

B.8.5.5 Load Operation Address Translation

36. L0 DTLB Miss due to Loads - Performance Impact: $\text{DTLB_MISSES.L0_MISS_LD} * 2 / \text{CPU_CLK_UNHALTED.CORE}$

High number of DTLB0 misses indicates that the data set that the workload uses spans a number of pages that is bigger than the DTLB0. The high number of misses is expected to impact workload performance only if the CPI (Ratio 1) is low - around 0.8. Otherwise, it is likely that the DTLB0 miss cycles are hidden by other latencies.

B.8.6 Memory Sub-System - Cache Misses Ratios

B.8.6.1 Locating Cache Misses in the Code

Intel Core microarchitecture provides you with precise events for retired load instructions that miss the L1 data cache or the L2 cache. As precise events they provide the instruction pointer of the instruction following the one that caused the event. Therefore the instruction that comes immediately prior to the pointed instruction is the one that causes the cache miss. These events are most helpful to quickly identify on which loads to focus to fix a performance problem. The events are:

`MEM_LOAD_RETIRE.L1D_MISS`

`MEM_LOAD_RETIRE.L1D_LINE_MISS`

`MEM_LOAD_RETIRE.L2_MISS`

`MEM_LOAD_RETIRE.L2_LINE_MISS`

B.8.6.2 L1 Data Cache Misses

37. L1 Data Cache Miss Rate: $\text{L1D_REPL} / \text{INST_RETIRED.ANY}$

A high value for L1 Data Cache Miss Rate indicates that the code misses the L1 data cache too often and pays the penalty of accessing the L2 cache. See also Loads Blocked by L1 Data Cache Rate (Ratio 32).

You can count separately cache misses due to loads, stores, and locked operations using the events `L1D_CACHE_LD.I_STATE`, `L1D_CACHE_ST.I_STATE`, and `L1D_CACHE_LOCK.I_STATE`, accordingly.

B.8.6.3 L2 Cache Misses

38. L2 Cache Miss Rate: $\text{L2_LINES_IN.SELF.ANY} / \text{INST_RETIRED.ANY}$

A high L2 Cache Miss Rate indicates that the running workload has a data set larger than the L2 cache. Some of the data might be evicted without being used. Unless all the required data is brought ahead of time by the hardware prefetcher or software prefetching instructions, bringing data from memory has a significant impact on the performance.

39. L2 Cache Demand Miss Rate: $L2_LINES_IN.SELF.DEMAND / INST_RETIRED.ANY$

A high value for L2 Cache Demand Miss Rate indicates that the hardware prefetchers are not exploited to bring the data this workload needs. Data is brought from memory when needed to be used and the workload bears memory latency for each such access.

B.8.7 Memory Sub-system - Prefetching

B.8.7.1 L1 Data Prefetching

The event `L1D_PREFETCH.REQUESTS` is counted whenever the DCU attempts to prefetch cache lines from the L2 (or memory) to the DCU. If you expect the DCU prefetchers to work and to count this event, but instead you detect the event `MEM_LOAD_RETIRE.L1D_MISS`, it might be that the IP prefetcher suffers from load instruction address collision of several loads.

B.8.7.2 L2 Hardware Prefetching

With the event `L2_LD.SELF.PREFETCH.MESI` you can count the number of prefetch requests that were made to the L2 by the L2 hardware prefetchers. The actual number of cache lines prefetched to the L2 is counted by the event `L2_LD.SELF.PREFETCH.I_STATE`.

B.8.7.3 Software Prefetching

The events for software prefetching cover each level of prefetching separately.

40. Useful PrefetchT0 Ratio: $SSE_PRE_MISS.L1 / SSE_PRE_EXEC.L1 * 100$

41. Useful PrefetchT1 and PrefetchT2 Ratio: $SSE_PRE_MISS.L2 / SSE_PRE_EXEC.L2 * 100$

A low value for any of the prefetch usefulness ratios indicates that some of the SSE prefetch instructions prefetch data that is already in the caches.

42. Late PrefetchT0 Ratio: $LOAD_HIT_PRE / SSE_PRE_EXEC.L1$

43. Late PrefetchT1 and PrefetchT2 Ratio: $LOAD_HIT_PRE / SSE_PRE_EXEC.L2$

A high value for any of the late prefetch ratios indicates that software prefetch instructions are issued too late and the load operations that use the prefetched data are waiting for the cache line to arrive.

B.8.8 Memory Sub-system - TLB Miss Ratios

44. TLB miss penalty: $PAGE_WALKS.CYCLES / CPU_CLK_UNHALTED.CORE * 100$

A high value for the TLB miss penalty ratio indicates that many cycles are spent on TLB misses. Reducing the number of TLB misses may improve performance. This ratio does not include DTLB0 miss penalties (see Ratio 37).

The following ratios help to focus on the kind of memory accesses that cause TLB misses most frequently. See "ITLB Miss Rate" (Ratio 6) for TLB misses due to instruction fetch.

45. DTLB Miss Rate: $DTLB_MISSES.ANY / INST_RETIRED.ANY$

A high value for DTLB Miss Rate indicates that the code accesses too many data pages within a short time, and causes many Data TLB misses.

46. DTLB Miss Rate due to Loads: $DTLB_MISSES.MISS_LD / INST_RETIRED.ANY$

A high value for DTLB Miss Rate due to Loads indicates that the code accesses loads data from too many pages within a short time, and causes many Data TLB misses. DTLB misses due to load operations may have a significant impact, since the DTLB miss increases the load operation latency. This ratio does not include DTLB0 miss penalties (see Ratio 37).

To precisely locate load instructions that caused DTLB misses you can use the precise event MEM_LOAD_RETIRE.DTLB_MISS.

47. DTLB Miss Rate due to Stores: $DTLB_MISSES.MISS_ST / INST_RETIRED.ANY$

A high value for DTLB Miss Rate due to Stores indicates that the code accesses too many data pages within a short time, and causes many Data TLB misses due to store operations. These misses can impact performance if they do not occur in parallel to other instructions. In addition, if there are many stores in a row, some of them missing the DTLB, it may cause stalls due to full store buffer.

B.8.9 Memory Sub-system - Core Interaction

B.8.9.1 Modified Data Sharing

48. Modified Data Sharing Ratio: $EXT_SNOOP.ALL_AGENTS.HITM / INST_RETIRED.ANY$

Frequent occurrences of modified data sharing may be due to two threads using and modifying data laid in one cache line. Modified data sharing causes L2 cache misses. When it happens unintentionally (aka false sharing) it usually causes demand misses that have high penalty. When false sharing is removed code performance can dramatically improve.

49. Local Modified Data Sharing Ratio: $EXT_SNOOP.THIS_AGENT.HITM / INST_RETIRED.ANY$

Modified Data Sharing Ratio indicates the amount of total modified data sharing observed in the system. For systems with several processors you can use Local Modified Data Sharing Ratio to indicate the amount of modified data sharing between two cores in the same processor. (In systems with one processor the two ratios are similar).

B.8.9.2 Fast Synchronization Penalty

50. Locked Operations Impact: $(L1D_CACHE_LOCK_DURATION + 20 * L1D_CACHE_LOCK.MESI) / CPU_CLK_UNHALTED.CORE * 100$

Fast synchronization is frequently implemented using locked memory accesses. A high value for Locked Operations Impact indicates that locked operations used in the workload have high penalty. The latency of a locked operation depends on the location of the data: L1 data cache, L2 cache, other core cache or memory.

B.8.9.3 Simultaneous Extensive Stores and Load Misses

51. Store Block by Snoop Ratio: $(STORE_BLOCK.SNOOP / CPU_CLK_UNHALTED.CORE) * 100$

A high value for "Store Block by Snoop Ratio" indicates that store operations are frequently blocked and performance is reduced. This happens when one core executes a dense stream of stores while the other core in the processor frequently snoops it for cache lines missing in its L1 data cache.

B.8.10 Memory Sub-system - Bus Characterization

B.8.10.1 Bus Utilization

52. Bus Utilization: $BUS_TRANS_ANY.ALL_AGENTS * 2 / CPU_CLK_UNHALTED.BUS * 100$

Bus Utilization is the percentage of bus cycles used for transferring bus transactions of any type. In single processor systems most of the bus transactions carry data. In multiprocessor systems some of the bus transactions are used to coordinate cache states to keep data coherency.

53. Data Bus Utilization: $BUS_DRDY_CLOCKS.ALL_AGENTS / CPU_CLK_UNHALTED.BUS * 100$

Data Bus Utilization is the percentage of bus cycles used for transferring data among all bus agents in the system, including processors and memory. High bus utilization indicates heavy traffic between the

processor(s) and memory. Memory sub-system latency can impact the performance of the program. For compute-intensive applications with high bus utilization, look for opportunities to improve data and code locality. For other types of applications (for example, copying large amounts of data from one memory area to another), try to maximize bus utilization.

54. Bus Not Ready Ratio: $BUS_BNR_DRV.ALL_AGENTS * 2 / CPU_CLK_UNHALTED.BUS * 100$

Bus Not Ready Ratio estimates the percentage of bus cycles during which new bus transactions cannot start. A high value for Bus Not Ready Ratio indicates that the bus is highly loaded. As a result of the Bus Not Ready (BNR) signal, new bus transactions might defer and their latency will have higher impact on program performance.

55. Burst Read in Bus Utilization: $BUS_TRANS_BRD.SELF * 2 / CPU_CLK_UNHALTED.BUS * 100$

A high value for Burst Read in Bus Utilization indicates that bus and memory latency of burst read operations may impact the performance of the program.

56. RFO in Bus Utilization: $BUS_TRANS_RFO.SELF * 2 / CPU_CLK_UNHALTED.BUS * 100$

A high value for RFO in Bus Utilization indicates that latency of Read For Ownership (RFO) transactions may impact the performance of the program. RFO transactions may have a higher impact on the program performance compared to other burst read operations (for example, as a result of loads that missed the L2). See also Ratio 31.

B.8.10.2 Modified Cache Lines Eviction

57. L2 Modified Lines Eviction Rate: $L2_M_LINES_OUT.SELF.ANY / INST_RETIRED.ANY$

When a new cache line is brought from memory, an existing cache line, possibly modified, is evicted from the L2 cache to make space for the new line. Frequent evictions of modified lines from the L2 cache increase the latency of the L2 cache misses and consume bus bandwidth.

58. Explicit WB in Bus Utilization: $BUS_TRANS_WB.SELF * 2 / CPU_CLK_UNHALTED.BUS * 100$

Explicit Write-back in Bus Utilization considers modified cache line evictions not only from the L2 cache but also from the L1 data cache. It represents the percentage of bus cycles used for explicit write-backs from the processor to memory.

APPENDIX C

RUNTIME PERFORMANCE OPTIMIZATION BLUEPRINT: INTEL® ARCHITECTURE OPTIMIZATION WITH LARGE CODE PAGES

This appendix provides a runtime optimization blueprint illustrating how the performance of runtimes can be improved by using large code pages.

C.1 OVERVIEW

Modern microprocessors support multiple page sizes for program code. For example, the current generation server platform Intel® Xeon® 8280 processor (based on Cascade Lake microarchitecture) supports 4 KB, 2 MB, and 4 MB pages for instructions and 4 KB, 2 MB, 4 MB, and 1 GB for data. Intel platforms have supported 4 KB and 2 MB pages for instructions as far back as 2011 in the Intel® Xeon® E5 processor (based on Ivy Bridge microarchitecture). Nevertheless, most programs use only one page size, which is the default of 4 KB. On Linux*, all applications are loaded into 4 KB memory pages by default. When examining performance bottlenecks for workloads on language runtimes, high stalls due to ITLB misses are found. This is largely due to the runtimes using only 4 KB pages for instructions.

Figure C-1 shows the CPU stalls resulting from ITLB misses on an Intel® Xeon® 8180 processor across a range of runtime workloads. On average, 7% of the cycles are stalled on ITLB misses. Benchmarks such as SPECjbb2015*¹ have low ITLB stalls (2.6%) compared to SPECjEnterprise*² which has high ITLB stalls (13%).

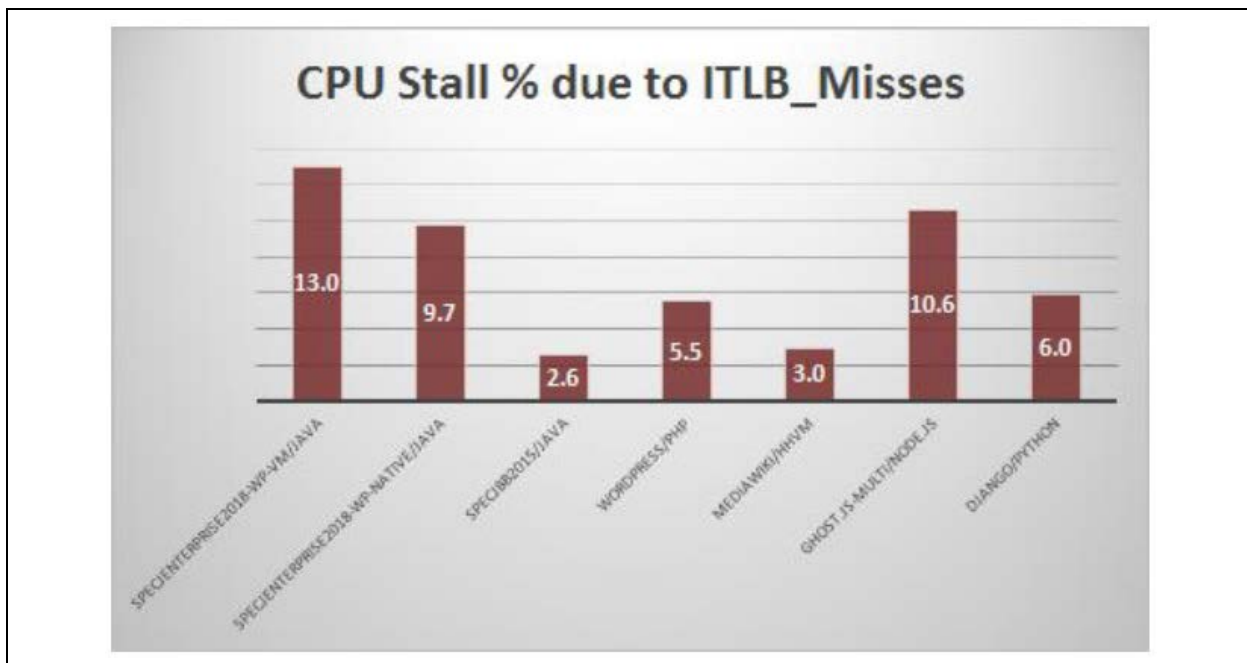

Figure C-1. ITLB Miss Stalls in Language Runtimes on Intel® Xeon® 8180 Processor

1. SPECjbb2015. (n.d.). SPECjbb2015 Design Document. Retrieved from SPEC - Standard Performance Evaluation Corporation: <https://www.spec.org/jbb2015/docs/designdocument.pdf>
2. SPECjEnterprise. (n.d.). SPECjEnterprise 2018 Web Profile. Retrieved from SPEC - Standard Performance Evaluation Corporation: <https://www.spec.org/jEnterprise2018web/>

C.1.1 ITLBs and Stalls

Intel processors have a Translation Lookaside Buffer (TLB), which stores the most recently used page-directory and page-table entries. TLBs speed up memory accesses when paging is enabled, by reducing the number of memory accesses that are required to read the page tables stored in system memory.

The TLBs are divided into the following groups:

- Instruction TLBs for 4KB pages.
- Data TLBs for 4KB pages.
- Instruction TLBs for large pages (2MB, 4MB pages).
- Data TLBs for large pages (2MB, 4MB, or 1GB pages).

On the Intel® Xeon® Platinum 8180 processor (based on Skylake Server microarchitecture), each processor TLB consists of dedicated L1 TLB for instruction cache (ITLB). Additionally, there is a unified L2 Second Level TLB (STLB) which is shared across both data and instructions, as shown below.

TLBs:

- ITLB
 - 4 KB page translations:
 - 128 entries; 8-way set associative.
 - Dynamic partitioning.
 - 2 MB / 4 MB page translations:
 - 8 entries per thread; fully associative.
 - Duplicated for each thread.
- STLB
 - 4 KB + 2 MB page translations:
 - 1536 entries; 12-way set associative, fixed partition.

When the processor does not find an entry in the ITLB, it has to do a page walk and populate the entry. A miss in the L1 (first level) ITLBs results in a very small penalty that can usually be hidden by the Out of Order (OOO) execution. A miss in the STLB results in the page walker being invoked; this penalty can be noticeable in the execution. During this process, the processor is stalled. The following table lists the TLB sizes across different Intel product generations.

Table C-1. Core TLB Structure Size and Organization Across Multiple Intel Product Generations

TLB	Sandy Bridge / Ivy Bridge Microarchitecture	Haswell / Broadwell Microarchitecture	Skylake / Cascade Lake Microarchitecture
L1 Instruction TLB	4K - 128, 4-way 2M/4M - 8/thread	4K - 128, 4 way 2M/4M - 8/thread	4K - 128, 8 way 2M/4M - 8/thread
L1 Data TLB	4K - 64, 4-way 2M/4M - 32 - 4-way 1G: 4, 4-way	4K - 64, 4-way 2M/4M - 32 - 4-way 1G: 4, 4-way	4K - 64, 4-way 2M/4M - 32 - 4-way 1G: 4, 4-way
L2 (Unified) STLB	4K - 512, 4-way	4K+2M shared: Haswell: 1024, 8-way Broadwell: 1536, 6-way 1G: 16, 4-way	4K+2M shared: 1536, 12-way 1G: 16, 4-way

From Table C-1 we can see that 2M page entries are shared in the L2 Unified TLB from Haswell microarchitecture onwards.

C.1.2 Large Pages

Both Windows* and Linux allow server applications to establish large-page memory regions. Using large 2MB pages, 20MB of memory can be mapped with just 10 pages; whereas with 4KB pages, 5120 pages are required. This means fewer TLB entries are needed, in turn reducing the number of TLB misses. Large pages can be used for code or for data, or both. Large pages for data are good to try if your workload has large heap. The blueprint described here focuses on using large pages for code.

C.2 DIAGNOSING THE PROBLEM

C.2.1 ITLB Misses

Intel has defined a Top-down Micro-architecture Analysis Method (TMAM) (see Appendix B, “Using Performance Monitoring Events”), which proposes a hierarchical execution cycles breakdown based on a set of new performance events. TMAM examines every instruction issue slot independently, and is therefore able to provide an accurate slot-level breakdown.

One of the components of the front-end latency is the ITLB miss stall. This metric represents the fraction of cycles the processor was stalled due to instruction TLB misses. On the Intel® Xeon® Scalable family of processors (based on Skylake Server microarchitecture), ITLB miss stall can be computed through two PMU counters, ICACHE_64B.IFTAG_STALL and CPU_CLK_UNHALTED.THREAD, using Equation 1.

Equation 1: Calculation of the ITLB Stall Metric

$$ITLB_Miss_{stall} = 100 * \left(\frac{ICACHE_64B.IFTAG_STALL}{CPU_CLK_UNHALTED.THREAD} \right)$$

Let us look at a concrete example. The Ghost.js workload has an ITLB_miss stall % of 10.6 when run in cluster mode across the whole system. A sampling of these two counters along with Equation 1 enables us to determine the % of ITLB_miss stall. A 10.6% stall due to ITLB misses is significant for this workload.

Table C-2. Calculating ITLB Miss Stall for Ghost.js

CPU_CLK_UNHALTED.THREAD	69838983
ICACHE_64B.IFTAG_STALL	7412534
ITLB Miss Stall %	10.6

Measuring ITLB miss stall is critical to determine if your workload on a runtime has an ITLB performance issue.

In Section C.6, “Case Study”, we show that even while running in single instance mode, Ghost.js has a 6.47% stall due to ITLB misses. When large pages are implemented, the performance improves by 5% and the ITLB misses are reduced by 30% and the ITLB Miss Stall is reduced from 6.47% to 2.87% .

Another key metric is the ITLB Misses Per Kilo Instructions (MPKI). This metric is a normalization of the ITLB misses against number of instructions, and it allows comparison between different systems. This metric is calculated using two PMU counters: ITLB_MISSES.WALK_COMPLETED and INST_RETIRED.ANY, as described in Equation 2. There are distinct PMU counters for large pages and 4KB pages, so Equation 2 shows the calculation for each PMU counter, respectively.

Equation 2: Calculating ITLB MPKI

$$ITLB_MPKI = 1000 * \left(\frac{ITLB_MISSES.WALK_COMPLETED}{INST_RETIRED.ANY} \right)$$

$$ITLB_4K_MPKI = 1000 * \left(\frac{ITLB_MISSES.WALK_COMPLETED_4K}{INST_RETIRED.ANY} \right)$$

$$ITLB_2M_4M_MPKI = 1000 * \left(\frac{ITLB_MISSES.WALK_COMPLETED_2M_4M}{INST_RETIRED.ANY} \right)$$

Upon calculating the MPKI for the runtime workloads in Figure C-2, we find that the ITLB MPKI and the ITLB 4K MPKI are very close to each other across the workloads. We can thus infer that most of the misses are from 4KB page walks. Another observation is that the benchmarks have lower ITLB MPKI than large real world software, which means that optimization decisions made on benchmarks might not translate to open source software.

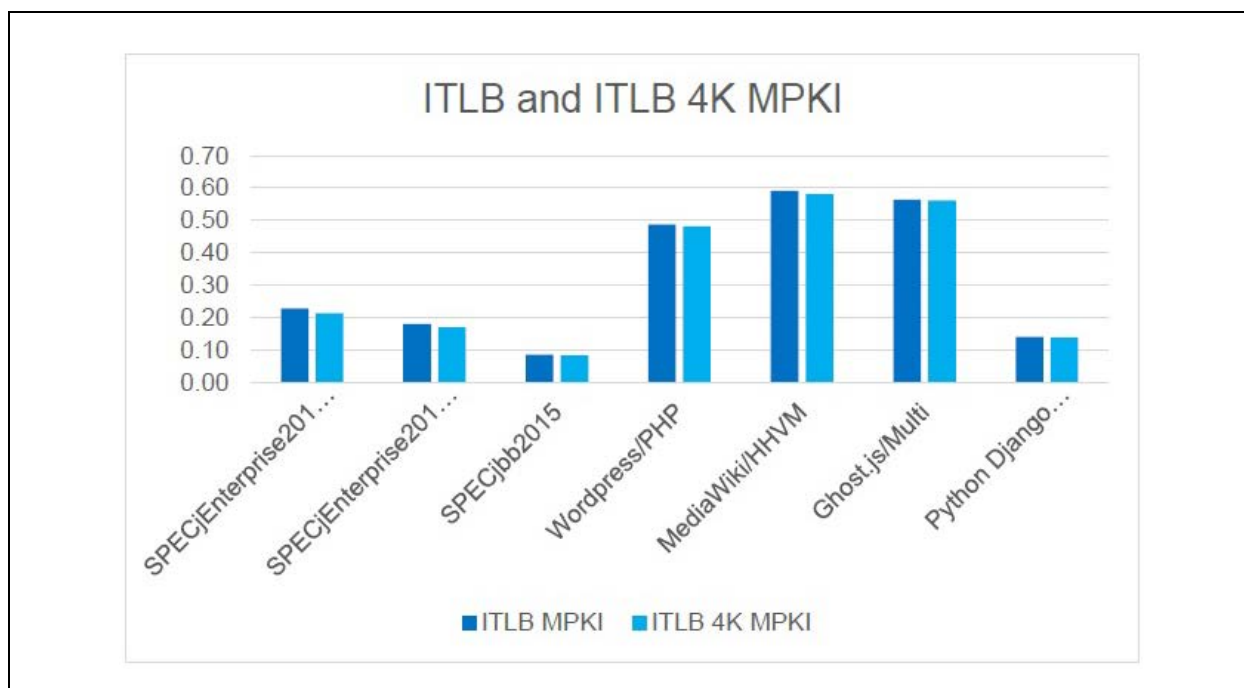

Figure C-2. ITLB and ITLB 4K MPKI Across Runtime Workloads

Having ITLB MPKI also enables us to do comparisons across different systems and workloads. Table C-3 compiles the ITLB MPKI across various workloads published^{1,2}. We can observe that there is not a direct correlation of binary size to ITLB MPKI. Some smaller binaries, such as MySQL, have one of the largest ITLB MPKI. When multiple threads are active, the ITLB MPKI almost doubles for both Ghost.js (single instance vs. multi instance) and Clang (-j1 vs -j4). The ITLB MPKI is much lower on newer servers (using

1. Ottoni, G., & Bertrand, M. (2017). Optimizing Function Placement for Large-Scale Data-Center Applications. CGO 2017.
 2. Lavaee, R., Criswell, J., & Ding, C. (Oct 2018). Codestitcher: Inter-Procedural Basic Block Layout Optimization. arXiv:1810.00905v1 [cs.PL].

Intel® Xeon® 8180 processors) as compared to older generation servers (using Intel® Xeon® E5 processors).

Table C-3. ITLB MPKI and Executable Sizes Across Various Workloads

Workload	Text (MB)	ITLB MPKI	System Details
AdIndexer	186	0.48	Dual 2.8 GHz Intel® Xeon® E5-2680 v2 (based on Ivy Bridge microarchitecture) server platform, with 10 cores and 25 MB LLC per processor.
HHVM	133	1.28	
Multifeed	199	0.40	
TAO	70	3.08	
MySQL	15	9.35	Two dual core Intel® Core™ i5-4278U (based on Haswell microarchitecture) processors running at 2.60 GHz. 32 KB instruction cache and a 256 KB second level unified cache private to each core. Both caches are 8-way set associative. The last level cache is 3 MB, 12-way set associative, and is shared by all core.
Clang -j4	50	2.23	
Clang -j1	50	1.01	
Firefox	81	1.54	
Apache PHP (w opcode)	16	0.33	
Apache PHP (w/o opcode)	16	0.96	
Python	2	0.19	
SPECjEnterprise2018-WP-VM		0.23	Intel® Xeon® Platinum 8180 (based on Skylake Server microarchitecture) with 112 cores @ 2.5 GHz (except MediaWiki/HHVM which is on a SKX-D with 18 cores).
SPECjEnterprise2018-WP-Native		0.18	
SPECjbb2015		0.09	
Wordpress/PHP		0.49	
MediaWiki/HHVM		0.59	
Ghost.js/Multi		0.56	
Ghost.js/Single		0.23	
Python Django (Instagram)		0.14	

C.2.2 Measuring the ITLB Miss Stall

Intel has a number of tools to automate measuring ITLB miss stalls, including Intel® VTune™ Profiler, EMON/EDP, and Linux PMU tools. This blueprint offers a convenient tool (`measure-perf-metric.sh`) based on `perf` to collect and derive various stall metrics on Intel® Xeon® Scalable processors. The tool is open sourced and available for download at <http://github.com/intel/iodlr>. Figure C-3 shows the command line to collect and derive ITLB miss stalls for an application with process id=69772. The tool output shows the application has a 3.09% ITLB miss stall.

```

$ git clone http://github.com/intel/iodlr
$ export PATH=`pwd`/iodlr/tools/:$PATH
$ measure-perf-metric.sh -p 69772 -t 30 -m itlb_stalls
Initializing for metric: itlb_stalls
Collect perf data for 30 seconds
perf stat -e cycles,instructions,icache_64b.iftag_stall
-----
Profile application with process id: 69772
-----
Calculating metric for: itlb_stalls
=====
Final itlb_stalls metric
-----
FORMULA: metric_ITLB_Misses(%) = 100*(a/b)
         where, a=icache_64b.iftag_stall
               b=cycles
=====
metric_ITLB_Misses(%)=3.09
    
```

Figure C-3. measure-perf-metric.sh Tool Usage for Process ID 69772 for 30 Seconds

Use the command `measure-perf-metric.sh -h` to display help messages for using the tool. Refer to the README.md file, which describes how to add new metrics to the tool.

C.2.3 Source of ITLB Misses

The next task is to find where the ITLB misses are coming from. They could be coming from the .text segment of the runtime, JITted code, some other dynamic library of the runtime, or native libraries in the user code. Performance tools such as perf, are required to determine where the ITLB misses are coming from.

In the case of Ghost.js that we examined earlier, most of the ITLB misses are coming from the .text segment of the Node.js¹ binary. We find this to be the case for several other Node.js workloads. Using the current release of node.js (v12.8.0) and the `measure-perf-metric.sh` tool, we can determine it for a Node.js workload. Figure C-4 shows that 65.23% of the stalls are in the node binary. The `-r` option to `measure-perf-metric.sh` uses `perf record` underneath to record the location in the source code that is causing the `itlb_stalls`.

```

$ measure-perf-metric.sh -p 58448 -r -t 20 -m itlb_stalls
Samples: 77K of event 'icache_64b.iftag_stall', Event count (approx.): 1558
Overhead  Shared Object      Command
65.23%   node                node
20.69%   perf-56817.map      node
4.53%    libc-2.27.so        node
    
```

Figure C-4. Using `measure-perf-metric.sh` with `-r` to Determine Where TLB Misses are Coming From

While Figure C-4 shows where the TLB miss overheads are coming from in terms of stalled cycles, we further analyze the latest upstream node.js (14.0.0-pre) to find the overhead in terms of ITLB miss counts using the `perf record -e frontend_retired.tlb_miss` command. We extract the report using the `perf script` command and filtering it based on the ITLB miss addresses. We find that 17.6% of ITLB misses are from JITted code and 72.8% from the node binary. We also find that “built-in” functions, which are part of node binary, account for 19.5% of the total ITLB misses.

On Linux and Windows systems, applications are loaded into memory into 4KB pages, which is the default on most systems. One way to reduce the ITLB misses is to use the larger page size, which has two benefits. The first benefit is fewer translations are required leading to fewer page walks. The second benefit is less space is used in the cache for storing translations, allowing more space to be available for the application code. Some older systems, such as one using Intel® Xeon® E5-2680 v2 processors (based on Ivy Bridge microarchitecture), have only 8 huge-page ITLB entries that are organized in a single level, so mapping all the text to large pages could cause a regression. However on Intel® Xeon® Platinum 8180 processors (based on Skylake Server microarchitecture), the STLB is shared by both 4KB and 2MB pages and has 1536 entries.

C.3 SOLUTION

C.3.1 Linux* and Large Pages

On the Linux OS, there are two ways of using large pages in an application:

1. NodeJS Foundation. (2019, August). Node.js JavaScript Runtime. Retrieved from Node.js JavaScript Runtime: <https://nodejs.org/en>

- **Explicit Huge Pages (hugetlbfs).** Part of the system memory is exposed as a file system that applications can mmap from. You can check the system through `cat /proc/meminfo` and see if lines like `HugePages_Total` are present.
- **Transparent Huge Pages (THP).** Linux also offers Transparent Hugepage Support which manages large pages automatically and is transparent for applications. The application can tell Linux to use large-pages-backed memory through `madvise`. You can check the system through `cat /sys/kernel/mm/transparent_hugepage/enabled`. If the values are `always` or `madvise`, then THP is available for the application. With `madvise`, THP is enabled only inside `MADV_HUGEPAGE` regions. Figure C-5 shows how to check the distribution for THP.

```
% cat /sys/kernel/mm/transparent_hugepage/enabled
always [madvise] never
% cat /sys/kernel/mm/transparent_hugepage/defrag
always defer defer+madvise [madvise] never
```

Figure C-5. Commands for Checking Linux* Distribution for THP

C.3.2 Large Pages for .text

There are a few solutions on Linux for solving the ITLB miss issue for .text segments:

- **Linking runtime with libhugetlbfs:** There are a number of support utilities and a library packaged collectively as `libhugetlbfs`. The library provides support for automatically backing text, data, heap, and shared memory segments with huge pages. This relies on explicit huge pages that the system administrator has to manage using tools like `hugeadm`.
- **Using the Intel Reference Implementation:** The reference implementations have both a C and a C++ module that automates the process using Transparent Huge Pages. A couple of API calls described below may be invoked at the beginning of the runtime to map a subset of the application’s .text segment to 2MB pages.
- **Using an explicit option or flag in the runtime:** The Node.js runtime has an implementation that is exposed using `--enable-largepages=on` when you run Node.js. The PHP runtime has a flag that can be added to the .ini file. For details, see: <https://www.php.net/manual/en/opcache.configuration.php>.

C.3.3 Reference Code

This blueprint offers a reference implementation that enables an application to utilize large pages for its execution. The open source reference implementation is available for download at <http://github.com/intel/iodlr>. Both a C and C++ implementation are provided.

The following is a high level description of the reference implementation and its APIs.

1. Find the .text region in memory.
 - a. Examine the `/proc/self/maps` to determine the currently mapped .text region and obtain the start and end addresses.
 - b. Modify the start address to point to the very beginning of the .text segment.
 - c. Align the start and end addresses to large page boundaries.
2. Move the .text region to large pages.
 - a. Map a temporary area and copy the original code there.
 - b. Use `mmap` using the start address with `MAP_FIXED` so we get exactly the same virtual address.
 - c. Use `madvise` with `MADV_HUGE_PAGE` to use anonymous 2MB pages.

- d. If successful, copy the code from the temporary area and unmap it.

There are five API calls provided in the reference implementation as shown in Figure C-6. Since the initial release, the ability to map DSOs has been added.

```

/* Performs a platform-dependent check to determine whether it is possible to map
   to large pages and stores the result of the check in result. */
map_status IsLargePagesEnabled(bool* result);

/* Attempts to map an application's .text region to large pages.

If the region is not aligned to 2 MiB then the portion of the page that lies below
the first multiple of 2 MiB remains mapped to small pages. Likewise, if the region
does not end at an address that is a multiple of 2 MiB, the remainder of the region
will remain mapped to small pages. The portion in-between will be mapped to large
pages. */
map_status MapStaticCodeToLargePages();

/* Retrieves an address range from the process' maps file associated with a DSO
   whose name matches lib_regex and attempts to map it to large pages */
map_status MapDSOToLargePages(const char* lib_regex);

/* Attempts to map the given address range to large pages. */
map_status MapStaticCodeRangeToLargePages(void* from, void* to);

/* A string containing the textual error message. The string is owned by the
   implementation and must not be freed. */
const char* MapStatusStr(map_status status, bool fulltext);
    
```

Figure C-6. API Calls Provided by the Intel Reference Implementation

C.3.4 Large Pages for the Heap

The Just-In-Time (JIT) compiler compiles methods on demand and the memory for the JITted code is allocated from the heap and subject to garbage collection.

The runtime can allocate heap on large pages using `mmap` with the flags argument set as `MAP_HUGETLB` (available since Linux 2.6.32) or `MAP_HUGE_2MB/ MAP_HUGE_1GB` (available since Linux 3.8). Alternatively, the heap region can be set to use transparent huge pages on Linux by using the `madvise` system call with `MADV_HUGE_PAGES`. When using `madvise`, the runtime must check that `transparent_hugepage` is set appropriately in the OS as either `madvise` or `always`, and not set to `never`.

The Java* VM has several options for mapping the Java heap with large pages¹. Since the JITted code is also on the heap, it allocates both the code and the data to large pages.

- XX:+UseHugeTLBFS `mmaps` Java heap into `hugetlbfs`, which should be prepared separately.
- XX:+UseTransparentHugePages `madvise-s` that Java heap should use THP.

1. Aleksey Shipilev, Redhat. (2019, 03 03). Transparent Huge Pages. Retrieved from JVM Anatomy Quarks: <https://shipilev.net/jvm/anatomy-quarks/2-transparent-huge-pages/>.

C.4 SOLUTION INTEGRATION

Integrating the solution into a new runtime requires the following changes:

1. Follow the style guide of the runtime and update the reference code.
2. Determine in the runtime where to make the API calls to remap the .text segment.
3. Change the build to link with the new files/library.
4. Provide a build time or runtime option to turn on this feature.

C.4.1 V8 Integration with the Reference Implementation

V8¹ is the Google* open source high-performance JavaScript* engine, written in C++. We integrated Intel's large pages reference implementation with V8 using the steps described above.

Here are the specific steps that we used to integrate the reference implementation within V8:

1. Check out, configure, and build v8 from: <https://v8.dev/docs/build-gn>.
2. Add call to `MapStaticCodeToLargePages()` at the beginning of `Shell::Main()` in `d8.cc`. Include `huge_page.h` in the source file.
3. Generate build files with the command:

```
gn gen out/foo -args='is_debug=false target_cpu="x64" is_clang=false'
```
4. Update the following build files:
 - a. Update `out/foo/obj/d8.ninja`
 Add `-Ipath/to/huge_page.h` to `include_dirs` variable
 Add `-Wl,-T path/to/ld.implicit.script` to `ldflags` variable
 - b. Update `out/foo/toolchain.ninja`
 Add `path/to/libhuge_page.a -lstdc++` to `link command`, before `-Wl,-endgroup`
5. Compile V8 with the command:

```
ninja -C out/bar/ d8
```

C.4.2 JAVA JVM Integration with the Reference Implementation

OpenJDK is a free and open-source implementation of the Java Platform, Standard Edition written in a combination of C and C++. We determined that Java executable unlike v8 or nodejs is a thin 'C' wrapper that uses `dlopen` to load the `libjvm`.

We integrated Intel's C large pages reference implementation with OpenJDK. Here are the specific steps that we used to integrate the reference implementation:

1. Check out, configure, and build OpenJDK using instructions at: <http://cr.openjdk.java.net/~ihse/demo-new-build-readme/common/doc/building.html>
2. Modify the code in `src/java.base/unix/native/libjli/java_md_solinux.c` to load `libjvm.so` into 2M pages:
 - Use the API to check if `LargePages` is supported.
 - Use the API `MapDSOToLargePages(const char* lib_regex)` to load `libjvm.so` into 2M pages.
3. Compile and rebuild the Java wrapper.

1. Google V8 JavaScript. (2019, August). V8 JavaScript Engine. Retrieved from V8 JavaScript Engine: <https://v8.dev/>

C.5 LIMITATIONS

There are several limitations to be aware of when using large pages:

- Fragmentation is an issue that is introduced when using large pages. If there is insufficient contiguous memory to assemble the large page, the operating system tries to reorganize the memory to satisfy the large page request, which can result in longer latencies. This can be mitigated by allocating large pages explicitly ahead of time. The reference code does not have support for explicit huge pages.
- Another issue is the additional execution time it takes to perform the algorithm in the Intel reference code. For short running programs, it adds additional execution time and might result in a slowdown rather than a speedup.
- We have recently encountered an issue when the current implementation is used with multiple instances of the same application. We have a report that it increases the LLC misses. We think this is due to the kernel not sharing the code after the remapping. We are investigating and working on a solution.

Tools like perf are no longer able to follow the symbols after the .text is remapped (Figure C-7) and the perf output will not have the symbols. You will need to provide the static symbols to perf in `/tmp/perf-PID.map` at startup.

```

1.35% node perf-12142.map [.] 0x0000562eb19e86aa
1.19% node perf-12142.map [.] 0x0000562eb19e8803
0.71% node perf-12142.map [.] 0x0000562eb19e891f
    
```

Figure C-7. perf Output Will Not Have the Proper Symbols After Large Page Mapping

C.6 CASE STUDY

This section details how this optimization helps performance and reduces ITLB misses in three workloads in three environments. The workloads are:

- Ghost¹, a fully open source, adaptable platform for building and running a modern online publication.
- Web Tooling², a suite designed to measure JavaScript-related workloads.
- MediaWiki³, a free and open-source wiki engine written in PHP.

This case study uses data running on the Intel® Xeon® Platinum 8180 processor (based on Skylake Server microarchitecture) for Ghost.js and Web Tooling and uses the Intel® Xeon® D-2100 processor⁴ for MediaWiki to showcase the benefits of large pages. The last case study demonstrates how to use Visualization tools to identify patterns in the data.

1. Ghost Team. (n.d.). Ghost: The professional publishing platform. Retrieved from Ghost Non Profit Web Site: <https://ghost.org/>.

2. Google Web Tooling. (2019, August). Web Tooling Benchmark. Retrieved from Web Tooling Benchmark: <https://github.com/v8/web-tooling-benchmark>.

3. Wikimedia Foundation. (2019, August). Mediawiki Software. Retrieved from Mediawiki Software: <http://mediawiki.org/wiki/Mediawiki>.

4. Xeon-D, I. (n.d.). Xeon-D. Retrieved from intel.com: <https://www.intel.com/content/www/us/en/products/processors/xeon/d-processors.html>.

C.6.1 Ghost.js Workload

Ghost is an open source blogging platform written in JavaScript and running on Node.js. We created a workload that has a single instance Ghost.js running on Node.js as a server and uses Apache Bench as a client to make requests. The performance is measured by a metric called Requests Per Second (RPS).

Intel developed and contributed the [2MB for Code PR](#) which is now merged into Node.js master. You can turn on large pages at runtime with the switch `--enable-largepages=on` in recent builds of Node.js. In older builds, you can enable large pages by building with `--use-largepages`. You can then compare the default build of Node.js with a build configured to use large pages.

Table C-4 shows the key metrics with Node.js and Node.js with large pages. RPS improves by 5%. The stalls due to the ITLB misses have reduced by 56%. The ITLB MPKI improved by 57%. The gains are mostly coming from the ITLB walk reduction which reduces by 55%. Note that the number of 2MB walks increases due to the use of 2MB pages.

Table C-4. Key Metrics for Ghost.js With and Without Large Pages

Metric	Node.js With Large Pages	Node.js Without Large Pages (Default)	Large Pages/Default
Throughput: Requests Per Second (RPS)	134.32	127.23	1.05
metric_ITLB_Misses(%)	2.87	6.47	0.44
metric cycles per txn	30048182	31426008	0.95
metric instructions per txn	46703106	47153431	0.99
ITLB_MISSES.WALK_COMPLETED	36799580	82504511	0.45
ITLB_MISSES.WALK_COMPLETED_2M_4M	938969	250959	3.74
ITLB_MISSES.WALK_COMPLETED_4K	35842004	82166894	0.44
metric ITLB MPKI	0.098	0.230	0.43
metric ITLB 4K MPKI	0.096	0.229	0.43
metric ITLB 2M_4M MPKI	0.002	0.0007	3.55

C.6.2 Web Tooling Workload

C.6.2.1 Node Version

Clear Linux* OS distributes Node 10.16.0 compiled with large pages support. We installed official Node 10.16.0 (which does not have large page support) on Ubuntu* 18.04 so we can compare the same version. Ubuntu only comes with Node 8.10.0 as part of the apt repository.

C.6.2.2 Web Tooling

This is a suite designed to measure the JavaScript-related workloads commonly used by web developers, such as the core workloads in popular tools like Babel or TypeScript. It has a number of sub-components and reports a throughput score.

C.6.2.3 Comparing Clear Linux* OS and Ubuntu*

Table C-5 shows the key metrics when running the Web Tooling workload. Although we observed small improvements in the throughput and cycles on Clear Linux when compared to Ubuntu, the Clear Linux

reduces the ITLB miss stall by 59%, the ITLB MPKI by 51%, and the 4KB MPKI by 52%. This is due to Clear Linux distributing Node.js compiled with the `--use-largepages` option. The throughput isn't impacted significantly, since the ITLB stalls were not as significant to begin with.

Table C-5. Key Metrics for Web Tooling across Clear Linux and Ubuntu 18.04

Metric	Clear Linux	Ubuntu 18.04	Clear Linux/Ubuntu
Throughput	10.91	10.80	1.01
metric_ITLB_Misses(%)	0.91	2.21	0.41
metric cycles per txn	531,821,553.08	537,631,089.06	0.98
metric instructions per txn	836,955,459.53	879,834,649.97	0.95
ITLB_MISSES.WALK_COMPLETED	8,145,008	17,230,161	0.47
ITLB_MISSES.WALK_COMPLETED_4K	7,909,985	17,070,769	0.46
ITLB_MISSES.WALK_COMPLETED_2M_4M	241,215	142,356	1.69
metric ITLB MPKI	0.0298	0.0604	0.49
metric ITLB 4K MPKI	0.0289	0.0598	0.48
metric ITLB 2M_4M MPKI	0.0009	0.0005	1.76

C.6.3 MediaWiki Workload

MediaWiki is a free and open-source wiki engine written in PHP. We used HHVM 3.25 to execute MediaWiki. HHVM maps the hot text pages to 2MB pages¹ and uses both the 4 KB and 2 MB pages. HHVM provides command line options `-vEval.MaxHotTextHugePages` and `-vEval.MapTCHuge` to enable large pages for the hot text pages and the Translation Cache pages (which holds the JIT generated code). In addition, it relies on code ordering to reduce the TLB misses. Table C-6 shows the improvement in metrics with large pages. There is a reduction of 16% for the ITLB miss stalls, a 29% reduction for the overall walks completed, and a 66% reduction in the hits to the shared TLBs. Skylake Server microarchitecture introduced new precise front-end events (e.g., `FRONTEND_RETIRED.ITLB_MISS` counts retired instructions that experienced ITLB (Instruction TLB) true miss) and we can see that all those are lower with large pages with `STLB_MISS` reducing by 23%.

Table C-6. Key Metrics for MediaWiki Workload on HHVM

Metric	Large Pages	No Large Pages	Large/No Large
metric_ITLB_Misses(%)	2.86	3.42	0.84
metric cycles per txn	44339066	44372158	0.99
metric instructions per txn	39129166	39168226	0.99
ITLB_MISSES.WALK_COMPLETED	7735.06	10850.57	0.71
ITLB_MISSES.WALK_COMPLETED_2M_4M	281.39	243.89	1.15
ITLB_MISSES.WALK_COMPLETED_4K	7453.67	10606.68	0.70
FRONTEND_RETIRED.ITLB_MISS	160403.87	162401.23	0.99
FRONTEND_RETIRED.L1I_MISS	160403.87	162401.23	0.99

1. Ottoni, G., & Bertrand, M. (2017). Optimizing Function Placement for Large-Scale Data-Center Applications. CGO 2017.

Table C-6. Key Metrics for MediaWiki Workload on HHVM (Contd.)

Metric	Large Pages	No Large Pages	Large/No Large
FRONTEND_RETIRED.L2_MISS	19566.98	20075.91	0.97
FRONTEND_RETIRED.STLB_MISS	3820.17	4961.98	0.77
metric ITLB MPKI	0.2426	0.351	0.69
metric ITLB 4K MPKI	0.2310	0.341	0.67
metric ITLB 2M_4M MPKI	0.0116	0.009	1.18

C.6.4 Visualization of Benefits

C.6.4.1 Precise Events

Intel PMU has Precise Event-Based Sampling (PEBS) which reports precise information, such as instruction address of cache misses. On the Intel® Xeon® Platinum 8180 (based on Skylake Server microarchitecture), the PEBS events support additional front-end events which are hardest to locate in the source code. Two of them are for ITLB misses as shown in Table C-7.

Table C-7. Precise Front-end Events for ITLB Misses

Event	Description
FRONTEND_RETIRED.ITLB_MISS (1st level)	Retired instructions following a true ITLB miss.
FRONTEND_RETIRED.STLB_MISS (2nd level)	Retired instructions following an ITLB and STLB miss (2nd level).

C.6.4.2 Visualizing Precise ITLB Miss

We can use Linux `perf` to record the `frontend_retired.itlb_miss` event and visualize the events with FlameScope, an Open Source tool from Netflix*. FlameScope is a visualization tool for exploring time ranges heatmaps and FlameGraphs. FlameScope starts by visualizing the input data as an interactive subsecond-offset heat map.

```

$ perf record -o /tmp/webtooling.node12.14.1.callgraph.itlb_miss.orig.out.b -b -e
frontend_retired.itlb_miss -- /home/dslo/ssuresh1/node-v12.14.1/node.orig --perf-
basic-prof dist/cli.js
[ perf record: Woken up 8 times to write data ]
[ perf record: Captured and wrote 1.944 MB
/tmp/webtooling.node12.14.1.callgraph.itlb_miss.orig.out.b (1539 samples) ]

$ perf script -i /tmp/webtooling.node12.14.1.callgraph.itlb_miss.orig.out --header >
webtooling.node12.14.1.itlb_miss.orig
    
```

Figure C-8. Using Perf Record with -e frontend_retired.itlb_miss to Determine ITLB Misses and Running Perf Script to Obtain Data for Importing into FlameScope

The output of perf script can be imported into FlameScope and we can visualize the ITLB misses. We can see that some portions of the workload have much more ITLB misses than others. When we compare Figure C-9 and Figure C-10 we can see that the heatmap is much sparser for the ITLB misses when we are using large pages in Node.js.

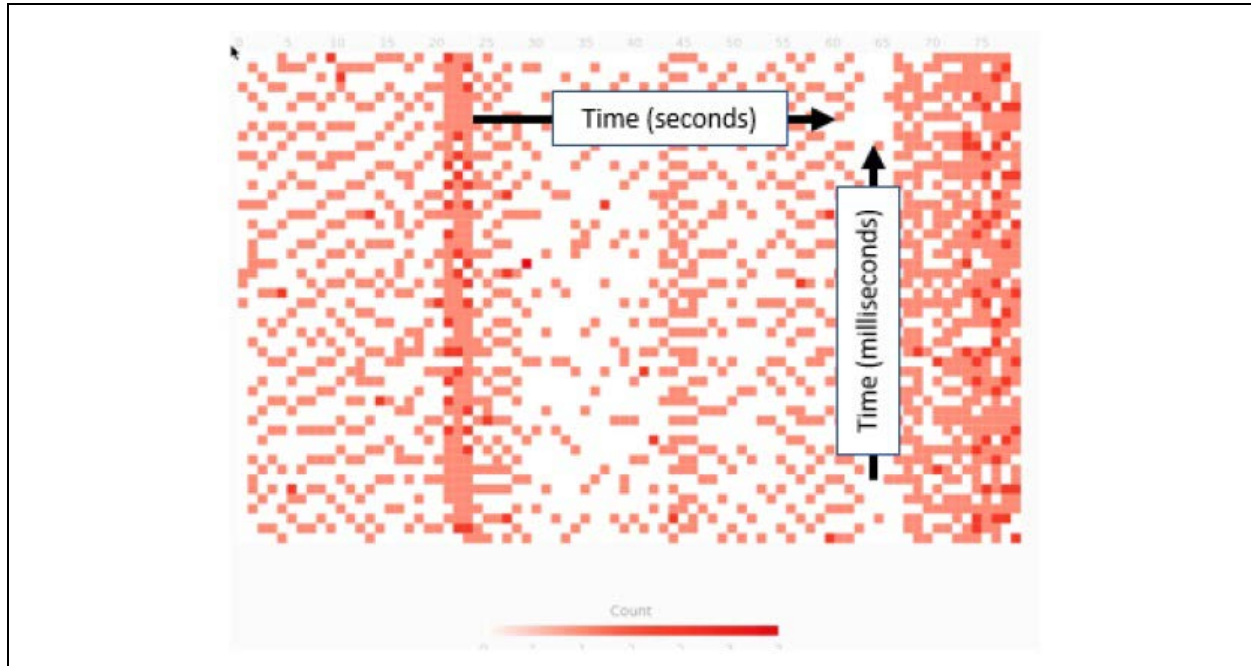

Figure C-9. Using FlameScope to Visualize the ITLB Misses Heatmap from the WebTooling Workload

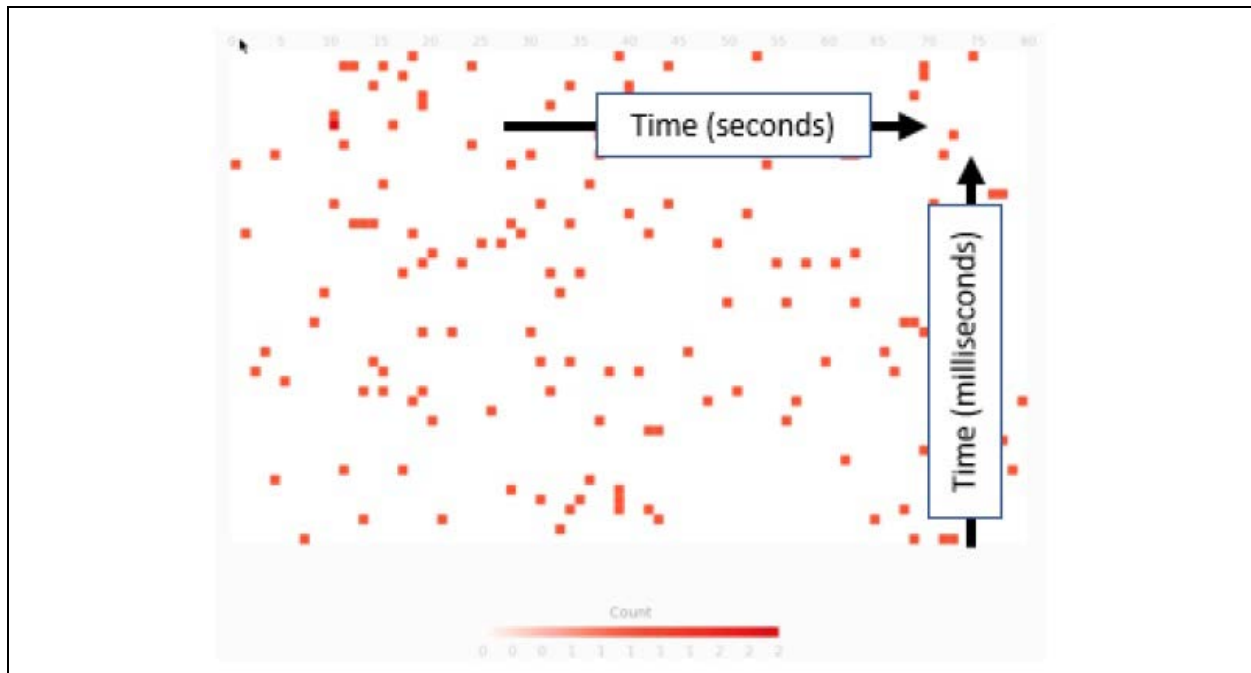

Figure C-10. Using FlameScope to Visualize the ITLB Misses Heatmap from the WebTooling Workload when Run with Large Pages

We also visualize the ITLB miss counts for the v8 “Built-in” functions by extracting the ITLB misses associated with the “Built-in” function from the `perf script` output. We plot the graph with the virtual address of the “Built-in” functions on y-axis and time on the x-axis (Figure C-11 and Figure C-12). Similar to FlameScope graphs, ITLB misses are sparser when we are using large pages in Node.js.

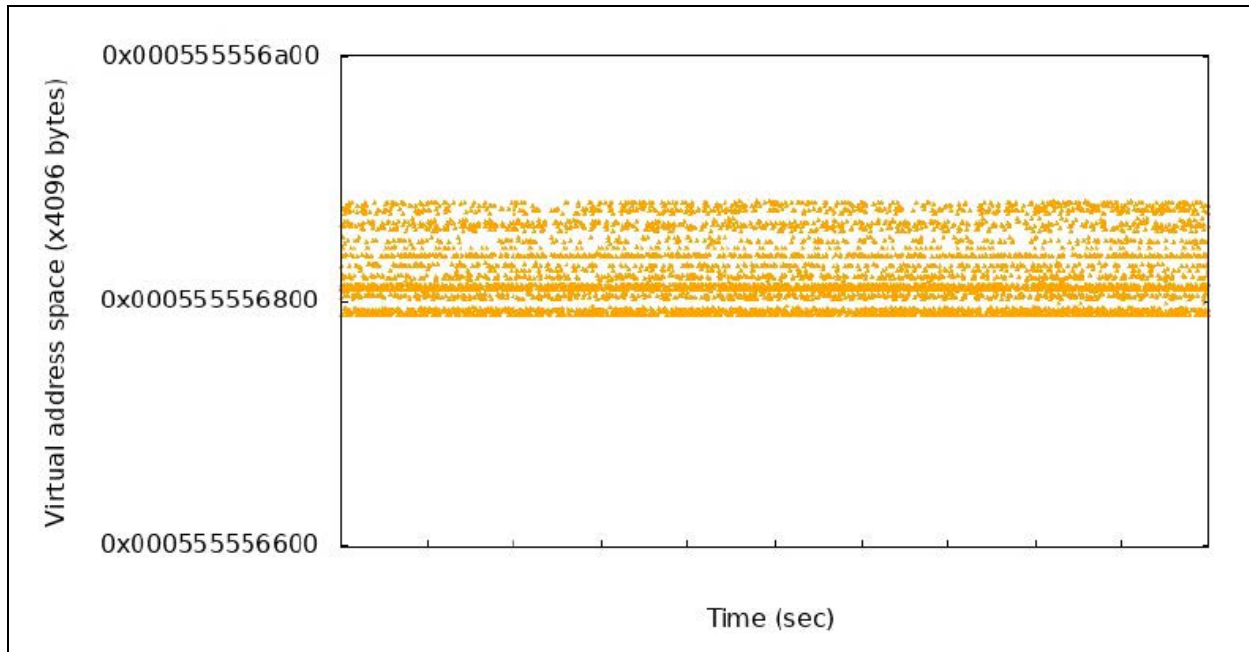

Figure C-11. Visualizing ITLB Miss Trends for “Built-in” Functions from the Ghost.js Workload

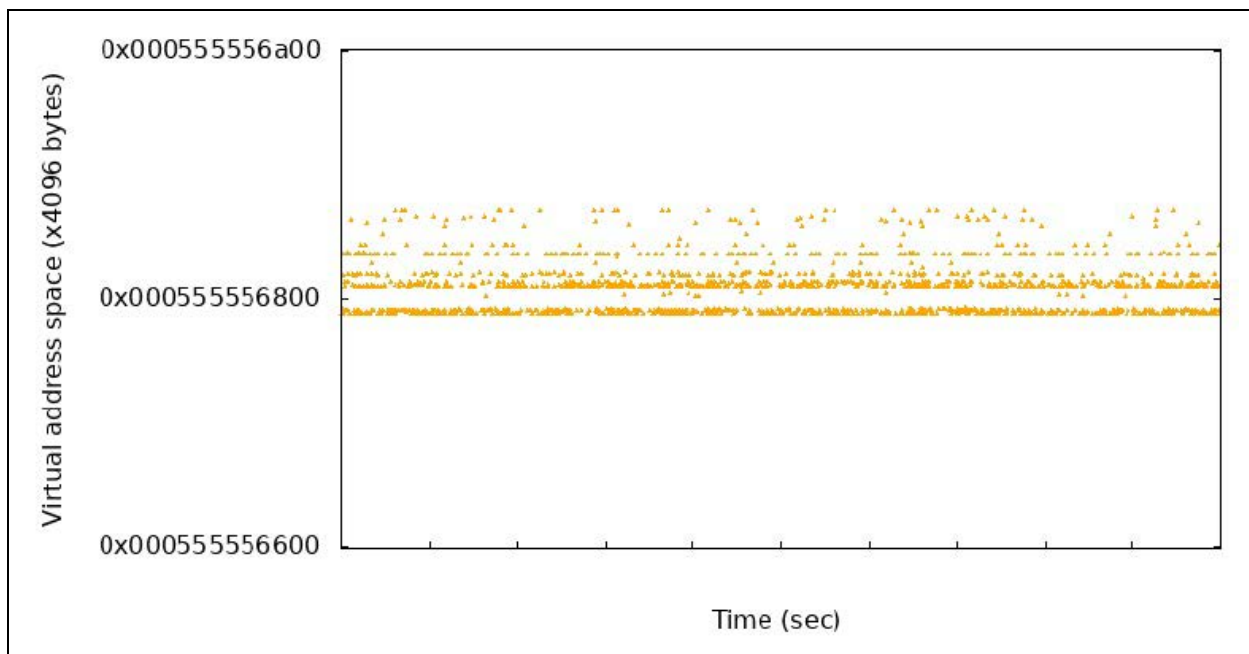

Figure C-12. Visualizing ITLB Miss Trends for “Built-in” Functions from the Ghost.js Workload When Run With Large Pages

C.7 SUMMARY

This runtime optimization blueprint described the problem that runtimes have with high ITLB miss stalls, and discussed how to diagnose the problem, as well as techniques and a reference implementation to solve the problem. A case study showed the benefits of integrating the solution into a new runtime. The three examples in the case study demonstrated that the use of 2M pages has the potential to improve ITLB Miss Stalls by 43%, ITLB Walks by 45%, and ITLB MPKI by 46%.

C.8 TEST CONFIGURATION DETAILS

Test configuration details are provided in the tables below.

Table C-8. System Details

System Info	DSLOHost011
Manufacturer	Intel Corporation
Product Name	S2600WFT
BIOS Version	SE5C620.86B.0X.01.0115.012820180604
OS	Ubuntu 18.04.3 LTS
Kernel	4.15.0-58-generic
Microcode	0x200005e

Table C-9. Processor Information

Model Name	Intel® Xeon® Platinum 8180 CPU @ 2.50GHz
Sockets	2
Hyper-Threading Enabled	Yes
Total CPU(s)	112
NUMA Nodes	2
NUMA cpulist	0-27,56-83 :: 28-55,84-111
L1d Cache	32K
L1i Cache	32K
L2 Cache	1024K
L3 Cache	39424K
Prefetchers Enabled	DCU HW, DCU IP, L2 HW, L2 Adj.
Turbo Enabled	True
Power & Perf Policy	Balanced
CPU Freq Driver	intel_pstate
CPU Freq Governor	powersave
Current CPU Freq MHz	1000

Table C-9. Processor Information (Contd.)

AVX2 Available	True
AVX512 Available	True
AVX512 Test	Passed
PPIN (CPU0)	c6aa1d2bcba4d86

Table C-10. Kernel Vulnerability Status

Vulnerabilities	DSLOHost011
CVE-2017-5753	OK (Mitigation: usercopy/swapgs barriers and __user pointer sanitization)
CVE-2017-5715	OK (Full retpoline + IBPB are mitigating the vulnerability)
CVE-2017-5754	OK (Mitigation: PTI)
CVE-2018-3640	OK (your CPU microcode mitigates the vulnerability)
CVE-2018-3639	OK (Mitigation: Speculative Store Bypass disabled via prctl and seccomp)
CVE-2018-3615	OK (your CPU vendor reported your CPU model as not vulnerable)
CVE-2018-3620	OK (Mitigation: PTE Inversion)
CVE-2018-3646	OK (this system is not running a hypervisor)
CVE-2018-12126	OK (Mitigation: Clear CPU buffers; SMT vulnerable)
CVE-2018-12130	OK (Mitigation: Clear CPU buffers; SMT vulnerable)
CVE-2018-12127	OK (Mitigation: Clear CPU buffers; SMT vulnerable)
CVE-2019-11091	OK (Mitigation: Clear CPU buffers; SMT vulnerable)

C.9 ADDITIONAL REFERENCES

In addition to the references cited in this appendix, the following references were used:

Ahmad Yasin, Intel Corporation. (2014). A Top-Down method for performance analysis and counters architecture. In IEEE International Symposium on Performance Analysis of Systems and Software, ISPASS , (pp. 35-44).

Performance Monitoring Event List. Retrieved from 01.org: <https://download.01.org/perfmon/SKX/>.

Panchenko, M. (2017). Building Binary Optimizer with LLVM. Retrieved from LLVM.ORG: https://llvm.org/devmtg/2016-03/Presentations/BOLT_EuroLLVM_2016.pdf.

Panchenko, M., Auler, R., Nell, B., Ottoni, & Guilherme. (n.d.). BOLT: A Practical Binary Optimizer for Datacenters and Beyond.

APPENDIX D

INSTRUCTION LATENCY AND THROUGHPUT

NOTE

Some recent processors have latency and throughput information posted here:
<https://software.intel.com/en-us/articles/intel-sdm#optimization>

This appendix contains tables showing the latency and throughput are associated with commonly used instructions¹. The instruction timing data varies across processors family/models. It contains the following sections:

- **Appendix D.1, “Overview”** — Provides an overview of issues related to instruction selection and scheduling.
- **Appendix D.2, “Definitions”** — Presents definitions.
- **Appendix D.3, “Latency and Throughput”** — Lists instruction throughput, latency associated with commonly-used instructions.

D.1 OVERVIEW

This appendix provides information to assembly language programmers and compiler writers. The information aids in the selection of instruction sequences (to minimize chain latency) and in the arrangement of instructions (assists in hardware processing). The performance impact of applying the information has been shown to be on the order of several percent. This is for applications not dominated by other performance factors, such as:

- Cache miss latencies.
- Bus bandwidth.
- I/O bandwidth.

Instruction selection and scheduling matters when the programmer has already addressed the performance issues discussed in Chapter 2:

- Observe store forwarding restrictions.
- Avoid cache line and memory order buffer splits.
- Do not inhibit branch prediction.
- Minimize the use of `xchg` instructions on memory locations.

While several items on the above list involve selecting the right instruction, this appendix focuses on the following issues. These are listed in priority order, though which item contributes most to performance varies by application:

- Maximize the flow of μ ops into the execution core. Instructions which consist of more than four μ ops require additional steps from microcode ROM. Instructions with longer micro-op flows incur a delay in the front end and reduce the supply of micro-ops to the execution core.

In Pentium 4 and Intel Xeon processors, transfers to microcode ROM often reduce how efficiently μ ops can be packed into the trace cache. Where possible, it is advisable to select instructions with four or fewer μ ops. For example, a 32-bit integer multiply with a memory operand fits in the trace cache without going to microcode, while a 16-bit integer multiply to memory does not.

1. Although instruction latency may be useful in some limited situations (e.g., a tight loop with a dependency chain that exposes instruction latency), software optimization on super-scalar, out-of-order microarchitecture, in general, will benefit much more on increasing the effective throughput of the larger-scale code path. Coding techniques that rely on instruction latency alone to influence the scheduling of instruction is likely to be sub-optimal as such coding technique is likely to interfere with the out-of-order machine or restrict the amount of instruction-level parallelism.

- Avoid resource conflicts. Interleaving instructions so that they don't compete for the same port or execution unit can increase throughput. For example, alternate PADDQ and PMULUDQ (each has a throughput of one issue per two clock cycles). When interleaved, they can achieve an effective throughput of one instruction per cycle because they use the same port but different execution units. Selecting instructions with fast throughput also helps to preserve issue port bandwidth, hide latency and allows for higher software performance.
- Minimize the latency of dependency chains that are on the critical path. For example, an operation to shift left by two bits executes faster when encoded as two adds than when it is encoded as a shift. If latency is not an issue, the shift results in a denser byte encoding.

In addition to the general and specific rules, coding guidelines and the instruction data provided in this manual, you can take advantage of the software performance analysis and tuning toolset available at <http://developer.intel.com/software/products/index.htm>. The tools include the Intel VTune Performance Analyzer, with its performance-monitoring capabilities.

D.2 DEFINITIONS

The data is listed in several tables. The tables contain the following:

- **Instruction Name** — The assembly mnemonic of each instruction.
- **Latency** — The number of clock cycles that are required for the execution core to complete the execution of all of the μ ops that form an instruction.
- **Throughput** — The number of clock cycles required to wait before the issue ports are free to accept the same instruction again. For many instructions, the throughput of an instruction can be significantly less than its latency.
- The case of RDRAND instruction latency and throughput is an exception to the definitions above, because the hardware facility that executes the RDRAND instruction resides in the uncore and is shared by all processor cores and logical processors in a physical package. The software observable latency and throughput using the sequence of "rdrand followby jnc" in a single-thread scenario can be as low as ~ 100 cycles. In third generation Intel Core processors based on Ivy Bridge microarchitecture, the total bandwidth to deliver random numbers via RDRAND by the uncore is about 500 MBytes/sec. Within the same processor core microarchitecture and different uncore implementations, RDRAND latency/throughput can vary across Intel Core and Intel Xeon processors.

D.3 LATENCY AND THROUGHPUT

This section presents the latency and throughput information for commonly-used instructions including: MMX technology, Streaming SIMD Extensions, subsequent generations of SIMD instruction extensions, and most of the frequently used general-purpose integer and x87 floating-point instructions.

Due to the complexity of dynamic execution and out-of-order nature of the execution core, the instruction latency data may not be sufficient to accurately predict realistic performance of actual code sequences based on adding instruction latency data.

- Instruction latency data is useful when tuning a dependency chain. However, dependency chains limit the out-of-order core's ability to execute micro-ops in parallel. Instruction throughput data are useful when tuning parallel code unencumbered by dependency chains.
- Numeric data in the tables is:
 - Approximate and subject to change in future implementations of the microarchitecture.
 - Not meant to be used as reference for instruction-level performance benchmarks. Comparison of instruction-level performance of microprocessors that are based on different microarchitectures is a complex subject and requires information that is beyond the scope of this manual.

Comparisons of latency and throughput data between different microarchitectures can be misleading.

Appendix D.3.1 provides latency and throughput data for the register-to-register instruction type. Appendix D.3.3 discusses how to adjust latency and throughput specifications for the register-to-memory and memory-to-register instructions.

In some cases, the latency or throughput figures given are just one half of a clock. This occurs only for the double-speed ALUs.

D.3.1 Latency and Throughput with Register Operands

Instruction latency and throughput data are presented in Table D-4 through Table D-18. Tables include AESNI, SSE4.2, SSE4.1, Supplemental Streaming SIMD Extension 3, Streaming SIMD Extension 3, Streaming SIMD Extension 2, Streaming SIMD Extension, MMX technology and most common Intel 64 and IA-32 instructions. Instruction latency and throughput for different processor microarchitectures are in separate columns.

Processor instruction timing data is implementation specific; it can vary between model encodings within the same family encoding (e.g. model = 3 vs model < 2). Separate sets of instruction latency and throughput are shown in the columns for CPUID signature 0xF2n and 0xF3n. The column represented by 0xF3n also applies to Intel processors with CPUID signature 0xF4n and 0xF6n. The notation 0xF2n represents the hex value of the lower 12 bits of the EAX register reported by CPUID instruction with input value of EAX = 1; 'F' indicates the family encoding value is 15, '2' indicates the model encoding is 2, 'n' indicates it applies to any value in the stepping encoding.

Intel Core Solo and Intel Core Duo processors are represented by 06_0EH. Processors based on 65 nm Intel Core microarchitecture are represented by 06_0FH. Processors based on Enhanced Intel Core microarchitecture are represented by 06_17H and 06_1DH. CPUID family/Model signatures of processors based on Nehalem microarchitecture are represented by 06_1AH, 06_1EH, 06_1FH, and 06_2EH. Processors based on Westmere microarchitecture are represented by 06_25H, 06_2CH and 06_2FH. Processors based on Sandy Bridge microarchitecture are represented by 06_2AH, 06_2DH. Processors based on Ivy Bridge microarchitecture are represented by 06_3AH, 06_3EH. Processors based on Haswell microarchitecture are represented by 06_3CH, 06_45H and 06_46H.

Table D-1. CPUID Signature Values of Of Recent Intel Microarchitectures

DisplayFamily_DisplayModel	Recent Intel Microarchitectures
06_4EH, 06_5EH	Skylake microarchitecture
06_3DH, 06_47H, 06_56H	Broadwell microarchitecture
06_3CH, 06_45H, 06_46H, 06_3FH	Haswell microarchitecture
06_3AH, 06_3EH	Ivy Bridge microarchitecture
06_2AH, 06_2DH	Sandy Bridge microarchitecture
06_25H, 06_2CH, 06_2FH	Intel microarchitecture Westmere
06_1AH, 06_1EH, 06_1FH, 06_2EH	Intel microarchitecture Nehalem
06_17H, 06_1DH	Enhanced Intel Core microarchitecture
06_0FH	Intel Core microarchitecture

Instruction latency varies by microarchitectures. Table D-2 lists SIMD extensions introduction in recent microarchitectures. Each microarchitecture may be associated with more than one signature value given by the CPUID's "display_family" and "display_model". Not all instruction set extensions are enabled in all processors associated with a particular family/model designation. To determine whether a given instruction set extension is supported, software must use the appropriate CPUID feature flag as described in *Intel® 64 and IA-32 Architectures Software Developer's Manual, Volume 2A*.

Table D-2. Instruction Extensions Introduction by Microarchitectures (CPUID Signature)

SIMD Instruction Extensions	DisplayFamily_DisplayModel							
	06_4EH, 06_5EH	06_3DH, 06_47H, 06_56H	06_3CH, 06_45H, 06_46H, 06_3FH	06_3AH, 06_3EH	06_2AH, 06_2DH	06_25H, 06_2CH, 06_2FH	06_1AH, 06_1EH, 06_1FH, 06_2EH	06_17H, 06_1DH
CLFLUSHOPT	Yes	No	No	No	No	No	No	No
ADX, RDSEED	Yes	Yes	No	No	No	No	No	No
AVX2, FMA, BMI1, BMI2	Yes	Yes	Yes	No	No	No	No	No
F16C, RDRAND, RWFSGSBASE	Yes	Yes	Yes	Yes	No	No	No	No
AVX	Yes	Yes	Yes	Yes	Yes	No	No	No
AESNI, PCLMULQDQ	Yes	Yes	Yes	Yes	Yes	Yes	No	No
SSE4.2, POPCNT	Yes	Yes	Yes	Yes	Yes	Yes	Yes	No
SSE4.1	Yes	Yes	Yes	Yes	Yes	Yes	Yes	Yes
SSSE3	Yes	Yes	Yes	Yes	Yes	Yes	Yes	Yes
SSE3	Yes	Yes	Yes	Yes	Yes	Yes	Yes	Yes
SSE2	Yes	Yes	Yes	Yes	Yes	Yes	Yes	Yes
SSE	Yes	Yes	Yes	Yes	Yes	Yes	Yes	Yes
MMX	Yes	Yes	Yes	Yes	Yes	Yes	Yes	Yes

Table D-3. BMI1, BMI2 and General Purpose Instructions

Instruction	Latency ¹		Throughput	
	06_4E, 06_5E	06_3D, 06_47, 06_56	06_4E, 06_5E	06_3D, 06_47, 06_56
ADCX	1	1	1	1
ADOX	1	1	1	1
RESEED	Similar to RDRAND	Similar to RDRAND	Similar to RDRAND	Similar to RDRAND

Table D-4. 256-bit AVX2 Instructions

Instruction	Latency ¹			Throughput		
	06_4E, 06_5E	06_3D, 06_47, 06_56	06_3C, 06_45, 06_46, 06_3F	06_4E, 06_5E	06_3D, 06_47, 06_56	06_3C, 06_45, 06_46, 06_3F
VEEXTRACT1128 xmm1, ymm2, imm	1	1	1	1	1	1
VMPSADBW	4	6	6	2	2	2
VPACKUSDW/SSWB	1	1	1	1	1	1
VPADDB/D/W/Q	1	1	1	0.33	0.5	0.5
VPADDSB	1	1	1	0.5	0.5	0.5
VPADDUSB	1	1	1	0.5	0.5	0.5
VPALIGNR	1	1	1	1	1	1
VPAVGB	1	1	1	0.5	0.5	0.5
VPBLEND	1	1	1	0.33	0.33	0.33
VPBLENDW	1	1	1	1	1	1
VPBLENDVB	1	2	2	1	2	2
VPBROADCASTB/D/SS/SD	3	3	3	1	1	1
VPCMPEQB/W/D	1	1	1	0.5	0.5	0.5
VPCMPEQQ	1	1	1	0.5	0.5	0.5
VPCMPGTQ	3	5	5	1	1	1
VPHADDW/D/SW	3	3	3	2	2	2
VINSERT1128 ymm1, ymm2, xmm, imm	3	3	3	1	1	1
VPMADDWD	5 ^b	5	5	0.5	1	1
VPMADDUBSW	5 ^b	5	5	0.5	1	1
VPMAXSD	1	1	1	0.5	0.5	0.5
VPMAXUD	1	1	1	0.5	0.5	0.5
VPMOVSX	3	3	3	1	1	1
VPMOVZX	3	3	3	1	1	1
VPMULDQ/UDQ	5 ^b	5	5	0.5	1	1
VPMULHRWSW	5 ^b	5	5	0.5	1	1
VPMULHW/LW	5 ^b	5	5	0.5	1	1
VPMULLD	10 ^b	10	10	1	2	2
VPOR/VPXOR	1	1	1	0.33	0.33	0.33
VPSADBW	3	5	5	1	1	1
VPSHUFB	1	1	1	1	1	1
VPSHUFD	1	1	1	1	1	1
VPSHUFLW/HW	1	1	1	1	1	1
VPSIGNB/D/W/Q	1	1	1	0.5	0.5	0.5
VPERMD/PS	3	3	3	1	1	1
VPSLLVD/Q	2	2	2	0.5	2	2

Table D-4. 256-bit AVX2 Instructions (Contd.)

Instruction	Latency ¹			Throughput		
	06_4E, 06_5E	06_3D, 06_47, 06_56	06_3C, 06_45, 06_46, 06_3F	06_4E, 06_5E	06_3D, 06_47, 06_56	06_3C, 06_45, 06_46, 06_3F
VPSRAVD	2	2	2	0.5	2	2
VPSRAD/W ymm1, ymm2, imm8	1	1	1	1	1	1
VPSLLDQ ymm1, ymm2, imm8	1	1	1	1	1	1
VPSLLQ/D/W ymm1, ymm2, imm8	1	1	1	1	1	1
VPSLLQ/D/W ymm, ymm, ymm	4	4	4	1	1	1
VPUNPCKHBW/WD/DQ/QDQ	1	1	1	1	1	1
VPUNPCKLBW/WD/DQ/QDQ	1	1	1	1	1	1
ALL VFMA	4	5	5	0.5	0.5	0.5
VPMASKMOVD/Q mem, ymm ^d , ymm				1	2	2
VPMASKMOVD/Q NUL, msk_0, ymm				>200 ^e	2	2
VPMASKMOVD/Q ymm, ymm ^d , mem	11	8	8	1	2	2
VPMASKMOVD/Q ymm, msk_0, [base+index] ^f	>200	~200	~200	>200	~200	~200

b: includes 1-cycle bubble due to bypass.

c: includes two 1-cycle bubbles due to bypass

d: MASKMOV instruction timing measured with L1 reference and mask register selecting at least 1 or more elements.

e: MASKMOV store instruction with a mask value selecting 0 elements and illegal address (NUL or non-NUL) incurs delay due to assist.

f: MASKMOV Load instruction with a mask value selecting 0 elements and certain addressing forms incur delay due to assist.

Table D-5. Gather Timing Data from L1D*

Instruction	Latency ¹			Throughput		
	06_4E, 06_5E	06_3D, 06_47, 06_56	06_3C/45/ 46/3F	06_4E, 06_5E	06_3D, 06_47, 06_56	06_3C/45/ 46/3F
VPGATHERDD/PS xmm, [vi128], xmm	~20	~17	~14	~4	~5	~7
VPGATHERQQ/PD xmm, [vi128], xmm	~18	~15	~12	~3	~4	~5
VPGATHERDD/PS ymm, [vi256], ymm	~22	~19	~20	~5	~6	~10
VPGATHERQQ/PD ymm, [vi256], ymm	~20	~16	~15	~4	~5	~7

* Gather Instructions fetch data elements via memory references. The timing data shown applies to memory references that reside within the L1 data cache and all mask elements selected

Table D-6. BMI1, BMI2 and General Purpose Instructions

Instruction	Latency ¹			Throughput		
	06_4E, 06_5E	06_3D, 06_47, 06_56	06_3C/45 /46/3F	06_4E, 06_5E	06_3D, 06_47, 06_56	06_3C/45 /46/3F
DisplayFamily_DisplayModel						
ANDN	1	1	1	0.5	0.5	0.5
BEXTR	2	2	2	0.5	0.5	0.5
BLSI/BLSMSK/BLSR	1	1	1	0.5	0.5	0.5
BZHI	1	1	1	0.5	0.5	0.5
MULX r64, r64, r64	4	4	4	1	1	1
PDEP/PEXT r64, r64, r64	3	3	3	1	1	1
RORX r64, r64, r64	1	1	1	0.5	0.5	0.5
SALX/SARX/SHLX r64, r64, r64	1	1	1	0.5	0.5	0.5
LZCNT/TZCNT	3	3	3	1	1	1

Table D-7. F16C,RDRAND Instructions

Instruction	Latency ¹				Throughput			
	06_4E, 06_5E	06_3D, 06_47, 06_56	06_3C/ 45/46/ 3F	06_3A/ 3E	06_4E, 06_5E	06_3D, 06_47, 06_56	06_3C/ 45/46/ 3F	06_3A/ 3E
DisplayFamily_DisplayModel								
RDRAND* r64	Varies	Varies	Varies	<200	<300	~250	~250	<200
VCVTPH2PS ymm1, xmm2	7	6	6	7	1	1	1	1
VCVTPH2PS xmm1, xmm2	5	4	4	6	1	1	1	1
VCVTPS2PH ymm1, xmm2, imm	7	6	6	10	1	1	1	1
VCVTPS2PH xmm1, xmm2, imm	5	4	4	9	1	1	1	1

* See Section D.2

Table D-8. 256-bit AVX Instructions

Instruction	Latency ¹				Throughput			
	06_4E, 06_5E	06_3D/ 47/56	06_3C/4 5/46/3F	06_3A /3E	06_4E, 06_5E	06_3D/ 47/56	06_3C/4 5/46/3F	06_3A /3E
DisplayFamily_DisplayModel								
VADDPD/PS ymm1, ymm2, ymm3	4	3	3	3	0.5	1	1	1
VADDSUBPD/PS ymm1, ymm2, ymm3	4	3	3	3	0.5	1	1	1
VANDNPD/PS ymm1, ymm2, ymm3	1	1	1	1	0.33	1	1	1
VANDPD/PS ymm1, ymm2, ymm3	1	1	1	1	0.33	1	1	1
VBLENDPD/PS ymm1, ymm2, ymm3, imm	1	1	1	1	0.33	0.33	0.33	0.5
VBLENDVPD/PS ymm1, ymm2, ymm3, ymm	1	2	2	1	1	2	2	1
VCMPPD/PS ymm1, ymm2, ymm3	4	3	3	3	0.5	1	1	1

Table D-8. 256-bit AVX Instructions (Contd.)

Instruction	Latency ¹				Throughput			
	06_4E, 06_5E	06_3D/ 47/56	06_3C/4 5/46/3F	06_3A /3E	06_4E, 06_5E	06_3D/ 47/56	06_3C/4 5/46/3F	06_3A /3E
DisplayFamily_DisplayModel								
VCVTDQ2PD ymm1, ymm2	7	6	6	4	1	1	1	1
VCVTDQ2PS ymm1, ymm2	4	3	3	3	0.5	1	1	1
VCVT(T)PD2DQ ymm1, ymm2	7	6	6	4	1	1	1	1
VCVTPD2PS ymm1, ymm2	7	6	6	4	1	1	1	1
VCVT(T)PS2DQ ymm1, ymm2	4	3	3	3	1	1	1	1
VCVTPS2PD ymm1, xmm2	7	4	4	2	1	1	1	1
VDIVPD ymm1, ymm2, ymm3	14	16-23	25-35	27-35	8	16	27	28
VDIVPS ymm1, ymm2, ymm3	11	13-17	17-21	18-21	5	10	13	14
VDPPS ymm1, ymm2, ymm3	13	12	14	12	1.5	2	2	2
VEXTRACTF128 xmm1, ymm2, imm	3	3	3	3	1	1	1	1
VINSERTF128 ymm1, xmm2, imm	3	3	3	3	1	1	1	1
VMAXPD/PS ymm1, ymm2, ymm3	4	3	3	3	0.5	1	1	1
VMINPD/PS ymm1, ymm2, ymm3	4	3	3	3	0.5	1	1	1
VMOVAPD/PS ymm1, ymm2	1	1	1	1	0.25	0.5	0.5	1
VMOVDDUP ymm1, ymm2	1	1	1	1	1	1	1	1
VMOVDQA/U ymm1, ymm2	1	1	1	1	0.25	0.25	0.25	0.5
VMOVMSKPD/PS ymm1, ymm2	2	2	2	1	1	1	1	1
VMOVQ xmm1, xmm2	1	1	1	1	0.33	0.33	0.33	0.33
VMOVD/Q xmm1, r32/r64	2	1	1	1	1	1	1	1
VMOVD/Q r32/r64, xmm	2	1	1	1	1	1	1	1
VMOVNTDQ/PS/PD					1	1	1	1
VMOVSHDUP ymm1, ymm2	1	1	1	1	1	1	1	1
VMOVSLDUP ymm1, ymm2	1	1	1	1	1	1	1	1
VMOVUPD/PS ymm1, ymm2	1	1	1	1	0.25	0.5	0.5	1
VMULPD/PS ymm1, ymm2, ymm3	4	3	5	5	0.5	0.5	0.5	1
VORPD/PS ymm1, ymm2, ymm3	1	1	1	1	0.33	1	1	1
VPERM2F128 ymm1, ymm2, ymm3, imm	3	3	3	2	1	1	1	1
VPERMILPD/PS ymm1, ymm2, ymm3	1	1	1	1	1	1	1	1
VRCPPS ymm1, ymm2	4	7	7	7	1	2	2	2
VROUNDPD/PS ymm1, ymm2, imm	8	6	6	3	1	2	2	1
VRSQRTPS ymm1, ymm2	4	7	7	7	1	2	2	2
VSHUFPD/PS ymm1, ymm2, ymm3, imm	1	1	1	1	1	1	1	1
VSQRTPD ymm1, ymm2	<18	19-35	19-35	19-35	<12	16-27	16-27	28
VSQRTPS ymm1, ymm2	12	18-21	18-21	18-21	<6	13	13	14
VSUBPD/PS ymm1, ymm2, imm	4	3	3	3	0.5	1	1	1

Table D-8. 256-bit AVX Instructions (Contd.)

Instruction	Latency ¹				Throughput			
	06_4E, 06_5E	06_3D/ 47/56	06_3C/4 5/46/3F	06_3A /3E	06_4E, 06_5E	06_3D/ 47/56	06_3C/4 5/46/3F	06_3A /3E
DisplayFamily_DisplayModel								
VTESTPS ymm1, ymm2	3	2	2	2	1	1	1	1
VUNPCKHPD/PS ymm1, ymm2, ymm3	1	1	1	1	1	1	1	1
VUNPCKLPD/PS ymm1, ymm2, ymm3	1	1	1	1	1	1	1	1
VXORPD/PS ymm1, ymm2, ymm3	1	1	1	1	0.33	1	1	1
VZEROUPPER	0	0	0	0	1	1	1	1
VZEROALL					12	8	8	9
VEXTRACTPS reg, xmm2, imm	3	2	2	2	1	1	1	1
VINSERTPS xmm1, xmm2, reg, imm	1	1	1	1	1	1	1	1
VMASKMOVPD/PS mem ^a , ymm, ymm					1	2	2	2
VMASKMOVPD/PS NUL, msk_0, ymm					>200 ^b	2	2	2
VMASKMOVPD/PS ymm, ymm ^a , mem	11	8	8	9	1	2	2	2
VMASKMOVPD/PS ymm, msk_0, [base+index] ^c	>200	~200	~200	~200	>200	~200	~200	~200

Latency and Throughput data for CPUID signature 06_3AH are generally the same as those of 06_2AH, only those that differ from 06_2AH are shown in the 06_3AH column.

a: MASKMOV instruction timing measured with L1 reference and mask register selecting at least 1 or more elements.

b: MASKMOV store instruction with a mask value selecting 0 elements and illegal address (NUL or non-NUL) incurs delay due to assist.

c: MASKMOV Load instruction with a mask value selecting 0 elements and certain addressing forms incur delay due to assist.

Latency of VEX.128 encoded AVX instructions should refer to corresponding legacy 128-bit instructions.

Table D-9. AESNI and PCLMULQDQ Instructions

Instruction	Latency ¹				Throughput			
	06_4E, 06_5E	06_3D/ 47/56	06_3C/4 5/46/3F	06_3A /3E	06_4E, 06_5E	06_3D/ 47/56	06_3C/4 5/46/3F	06_3A /3E
DisplayFamily_DisplayModel								
AESDEC/AESDECLAST xmm1, xmm2	4	7	7	8	1	1	1	1
AESENC/AESENCLAST xmm1, xmm2	4	7	7	8	1	1	1	1
AESIMC xmm1, xmm2	8	14	14	14	2	2	2	2
AESKEYGENASSIST xmm1, xmm2, imm	12	10	10	10	12	8	8	8
PCLMULQDQ xmm1, xmm2, imm	7 ^b	5	7	14	1	1	2	8

b: includes 1-cycle bubble due to bypass.

Table D-10. SSE4.2 Instructions

Instruction	Latency ¹				Throughput			
	06_4E, 06_5E	06_3D /47/56	06_3C /45/46 /3F	06_3A /3E/2A /2D	06_4E, 06_5E	06_3D /47/56	06_3C/ 45/46/ 3F	06_3A /3E/2A /2D
DisplayFamily_DisplayModel								
CRC32 r32, r32	3	3	3	3	1	1	1	1
PCMPESTRI xmm1, xmm2, imm	15	10	10	11	5	4	4	4
PCMPESTRM xmm1, xmm2, imm	10	10	10	11	6	5	5	4
PCMPISTRI xmm1, xmm2, imm	15	10	10	11	3	3	3	3
PCMPISTRM xmm1, xmm2, imm	15	11	11	11	3	3	3	3
PCMPGTQ xmm1, xmm2	3	5	5	5	0.33	1	1	1
POPCNT r32, r32	3	3	3	3	1	1	1	1
POPCNT r64, r64	3	3	3	3	1	1	1	1

Table D-11. SSE4.1 Instructions

Instruction	Latency ¹				Throughput			
	06_4E, 06_5E	06_3D /47/56	06_3C/ 45/46/ 3F	06_3A /3E/2A /2D	06_4E, 06_5E	06_3D/ 47/56	06_3C/ 45/46/ 3F	06_3A /3E/2A /2D
DisplayFamily_DisplayModel								
BLENDDP/S xmm1, xmm2, imm	1	1	1	1	0.33	0.33	0.33	0.5
BLENDVPD/S xmm1, xmm2	1	2	2	2	1	2	2	1
DPPD xmm1, xmm2	9	7	9	9	1	1	1	1
DPPS xmm1, xmm2	13	12	14	13	2	2	2	2
EXTRACTPS xmm1, xmm2, imm	3	2	2	2	1	1	1	1
INSERTPS xmm1, xmm2, imm	1	1	1	1	1	1	1	1
MPSADBW xmm1, xmm2, imm	4	6	6	6	2	2	2	1
PACKUSDW xmm1, xmm2	1	1	1	1	1	1	1	0.5
PBLENVB xmm1, xmm2	2	2	2	2	2	2	2	1
PBLENDW xmm1, xmm2, imm	1	1	1	1	1	1	1	0.5
PCMPEQQ xmm1, xmm2	1	1	1	1	0.5	0.5	0.5	0.5
PEXTRB/W/D reg, xmm1, imm	3	3	3	3	1	1	1	1
PHMINPOSUW xmm1, xmm2	4	5	5	5	1	1	1	1
PINSRB/W/D xmm1, reg, imm	2	2	2	2	1	1	1	1
PMASB/SD xmm1, xmm2	1	1	1	1	0.5	0.5	0.5	0.5
PMAXUW/UD xmm1, xmm2	1	1	1	1	0.5	0.5	0.5	0.5
PMINSB/SD xmm1, xmm2	1	1	1	1	0.5	0.5	0.5	0.5
PMINUW/UD xmm1, xmm2	1	1	1	1	0.5	0.5	0.5	0.5
PMOVSXBD/BW/BQ xmm1, xmm2	1	1	1	1	1	1	1	0.5
PMOVSXWD/WQ/DQ xmm1, xmm2	1	1	1	1	1	1	1	0.5

Table D-11. SSE4.1 Instructions (Contd.)

Instruction	Latency ¹				Throughput			
	06_4E, 06_5E	06_3D /47/56	06_3C/ 45/46/ 3F	06_3A /3E/2A /2D	06_4E, 06_5E	06_3D/ 47/56	06_3C/ 45/46/ 3F	06_3A /3E/2A /2D
DisplayFamily_DisplayModel								
PMOVZXBD/BW/BQ xmm1, xmm2	1	1	1	1	1	1	1	0.5
PMOVZXWD/WQ/DQ xmm1, xmm2	1	1	1	1	1	1	1	0.5
PMULDQ xmm1, xmm2	5 ^b	5	5	5	0.5	1	1	1
PMULLD xmm1, xmm2	10 ^c	10	10	5	2	2	2	1
PTEST xmm1, xmm2	3	2	2	2	1	1	1	1
ROUNDPD/PS xmm1, xmm2, imm	6	6	6	3	2	2	2	1
ROUNDSD/SS xmm1, xmm2, imm	6	6	6	3	2	2	2	1

b: includes 1-cycle bubble due to bypass

c: includes two 1-cycle bubbles due to bypass

Table D-12. Supplemental Streaming SIMD Extension 3 Instructions

Instruction	Latency ¹				Throughput			
	06_4E, 06_5E	06_3D/ 47/56	06_3C/ 45/46/ 3F	06_3A/ 3E/2A/ 2D	06_4E, 06_5E	06_3D/ 47/56	06_3C/ 45/46/ 3F	06_3A/ 3E/2A/ 2D
DisplayFamily_DisplayModel								
PALIGNR xmm1, xmm2, imm	1	1	1	1	1	1	1	0.5
PHADD xmm1, xmm2	3	3	3	3	2	2	2	1.5
PHADDW xmm1, xmm2	3	3	3	3	2	2	2	1.5
PHADDSW xmm1, xmm2	3	3	3	3	2	2	2	1.5
PHSUBD xmm1, xmm2	3	3	3	3	2	2	2	1.5
PHSUBW xmm1, xmm2	3	3	3	3	2	2	2	1.5
PHSUBSW xmm1, xmm2	3	3	3	3	2	2	2	1.5
PMADDUBSW xmm1, xmm2	5 ^b	5	5	5	0.5	1	1	1
PMULHRSW xmm1, xmm2	5 ^b	5	5	5	0.5	1	1	1
PSHUFB xmm1, xmm2	1	1	1	1	1	1	1	0.5
PSIGNB/D/W xmm1, xmm2	1	1	1	1	0.5	0.5	0.5	0.5
PABSB/D/W xmm1, xmm2	1	1	1	1	0.5	0.5	0.5	0.5

b: includes 1-cycle bubble due to bypass

Table D-13. Streaming SIMD Extension 3 SIMD Floating-point Instructions

Instruction	Latency ¹				Throughput			
	06_4E,06_5E	06_3D/47/56	06_3C/45/46/3F	06_3A/3E/2A/2D	06_4E,06_5E	06_3D/47/56	06_3C/45/46/3F	06_3A/3E/2A/2D
ADDSDUP/ADDSDUPS	4	3	3	3	0.5	1	1	1
HADDPD xmm1, xmm2	6	5	5	5	2	2	2	2
HADDPS xmm1, xmm2	6	5	5	5	2	2	2	2
HSUBPD xmm1, xmm2	6	5	5	5	2	2	2	2
HSUBPS xmm1, xmm2	6	5	5	5	2	2	2	2
MOVDDUP xmm1, xmm2	1	1	1	1	1	1	1	1
MOVSHDUP xmm1, xmm2	1	1	1	1	1	1	1	1
MOVSLDUP xmm1, xmm2	1	1	1	1	1	1	1	1

Table D-14. Streaming SIMD Extension 2 128-bit Integer Instructions

Instruction	Latency ¹				Throughput			
	06_4E,06_5E	06_3D/47/56	06_3C/45/46/3F	06_3A/3E/2A/2D	06_4E,06_5E	06_3D/47/56	06_3C/45/46/3F	06_3A/3E/2A/2D
CPUID								
CVTTPS2DQ xmm, xmm	3	3	3	3	1	1	1	1
CVTTPS2DQ xmm, xmm	3	3	3	3	1	1	1	1
MASKMOVDQU xmm, xmm					7	6	6	6
MOVD xmm, r64/r32	2	1	1	1	1	1	1	1
MOVD r64/r32, xmm	2	1	1	1	1	1	1	1
MOVDQA xmm, xmm	1	1	1	1	0.25	0.33	0.33	0.5
MOVDQU xmm, xmm	1	1	1	1	0.25	0.33	0.33	0.5
MOVQ xmm, xmm	1	1	1	1	0.33	0.33	0.33	0.33
PACKSSWB/PACKSSDW/ PACKUSWB xmm, xmm	1	1	1	1	1	1	1	0.5
PADB/PADDW/PADDD xmm, xmm	1	1	1	1	0.33	0.5	0.5	0.5
PADDSB/PADDSW/ PADDUSB/PADDUSW xmm, xmm	1	1	1	1	0.5	0.5	0.5	0.5
PADDQ/PSUBQ ³ xmm, xmm	1	1	1	1	0.33	0.5	0.5	0.5
PAND xmm, xmm	1	1	1	1	0.33	0.33	0.33	0.33
PANDN xmm, xmm	1	1	1	1	0.33	0.33	0.33	0.33
PAVGB/PAVGW xmm, xmm	1	1	1	1	0.5	0.5	0.5	0.5
PCMPEQB/PCMPEQD/ PCMPEQW xmm, xmm	1	1	1	1	0.5	0.5	0.5	0.5
PCMPGTB/PCMPGTD/PCMPGTW xmm, xmm	1	1	1	1	0.5	0.5	0.5	0.5
PEXTRW r32, xmm, imm8	3	3	3	3	1	1	1	1

Table D-14. Streaming SIMD Extension 2 128-bit Integer Instructions (Contd.)

Instruction	Latency ¹				Throughput			
	06_4E, 06_5E	06_3D/4 7/56	06_3C/4 5/46/3F	06_3A/3 E/2A/2D	06_4E, 06_5E	06_3D/4 7/56	06_3C/4 5/46/3F	06_3A/3 E/2A/2D
PINSRW xmm, r32, imm8	2	2	2	2	2	2	2	1
PMADDWD xmm, xmm	5 ^b	5	5	5	0.5	1	1	1
PMAX xmm, xmm	1	1	1	1	0.5	0.5	0.5	0.5
PMIN xmm, xmm	1	1	1	1	0.5	0.5	0.5	0.5
PMOVMASK ³ r32, xmm	2	2	2	2	1	1	1	1
PMULHUW/PMULHW/ PMULLW xmm, xmm	5 ^b	5	5	5	0.5	1	1	1
PMULUDQ xmm, xmm	5 ^b	5	5	5	0.5	1	1	1
POR xmm, xmm	1	1	1	1	0.33	0.33	0.33	0.33
PSADBW xmm, xmm	3	5	5	5	1	1	1	1
PSHUFD xmm, xmm, imm8	1	1	1	1	1	1	1	0.5
PSHUFW xmm, xmm, imm8	1	1	1	1	1	1	1	0.5
PSHUFLW xmm, xmm, imm8	1	1	1	1	1	1	1	0.5
PSLLDQ xmm, imm8	1	1	1	1	1	1	1	0.5
PSLLW/PSLLD/PSLLQ xmm, imm8	1	1	1	1	1	1	1	1
PSLL/PSRL xmm, xmm	2	2	2	2	1	1	1	1
PSRAW/PSRAD xmm, imm8	1	1	1	1	1	1	1	1
PSRAW/PSRAD xmm, xmm	2	2	2	2	1	1	1	1
PSRLDQ xmm, imm8	1	1	1	1	1	1	1	0.5
PSRLW/PSRLD/PSRLQ xmm, imm8	1	1	1	1	1	1	1	1
PSUBB/PSUBW/PSUBD xmm, xmm	1	1	1	1	0.33	0.5	0.5	0.5
PSUBSB/PSUBSW/PSUBUSB /PSUBUSW xmm, xmm	1	1	1	1	0.5	0.5	0.5	0.5
PUNPCKHBW/PUNPCKHWD/ PUNPCKHDQ xmm, xmm	1	1	1	1	1	1	1	0.5
PUNPCKHQDQ xmm, xmm	1	1	1	1	1	1	1	0.5
PUNPCKLBW/PUNPCKLWD/ PUNPCKLDQ xmm, xmm	1	1	1	1	1	1	1	0.5
PUNPCKLQDQ xmm, xmm	1	1	1	1	1	1	1	0.5
PXOR xmm, xmm	1	1	1	1	0.33	0.33	0.33	0.33

b: includes 1-cycle bubble due to bypass

Table D-15. Streaming SIMD Extension 2 Double-precision Floating-point Instructions

Instruction	Latency ¹				Throughput			
	06_4E, 06_5E	06_3D/4 7/56	06_3C/4 5/46/3F	06_2A/2 D(06_3A/ 3E)	06_4E, 06_5E	06_3D/4 7/56	06_3C/4 5/46/3F	06_2A/2 D(06_3A/ 3E)
ADDPD xmm, xmm	4	3	3	3	0.5	1	1	1
ADDSD xmm, xmm	4	3	3	3	0.5	1	1	1
ANDNPD xmm, xmm	1	1	1	1	0.33	1	1	1
ANDPD xmm, xmm	1	1	1	1	0.33	1	1	1
CMPPD xmm, xmm, imm8	4	3	3	3	0.5	1	1	1
CMPSD xmm, xmm, imm8	4	3	3	3	0.5	1	1	1
COMISD xmm, xmm	2	2	2	2	1	1	1	1
CVTDQ2PD xmm, xmm	5	4	4	4	1	1	1	1
CVTDQ2PS xmm, xmm	4	3	3	3	1	1	1	1
CVTPD2DQ xmm, xmm	5	4	4	4	1	1	1	1
CVTPD2PS xmm, xmm	5	4	4	4	1	1	1	1
CVT[T]PS2DQ xmm, xmm	4	3	3	3	1	1	1	1
CVTPS2PD xmm, xmm	5	2	2	2	1	1	1	1
CVT[T]SD2SI r64/r32, xmm	6	4	4	5	1	1	1	1
CVTSD2SS xmm, xmm	5	4	4	4	1	1	1	1
CVTSI2SD xmm, r64/r32	5	3	3	4	1	1	1	1
CVTSS2SD xmm, xmm	5	2	2	2	1	1	1	1
CVTTPD2DQ xmm, xmm	5	4	4	4	1	1	1	1
CVTTSD2SI r32, xmm	6	4	4	5	1	1	1	1
DIVPD xmm, xmm ¹	14	<14	14-20	16-22 (15-20)	4	8	13	22(14)
DIVSD xmm, xmm	14	<14	14-20	16-22 (15-20)	4	5	13	22(14)
MAXPD xmm, xmm	4	3	3	3	0.5	1	1	1
MAXSD xmm, xmm	4	3	3	3	0.5	1	1	1
MINPD xmm, xmm	4	3	3	3	0.5	1	1	1
MINSD xmm, xmm	4	3	3	3	0.5	1	1	1
MOVAPD xmm, xmm	1	1	1	1	0.33	0.5	0.5	1
MOVMSKPD r64/r32, xmm	2	2	2	2	1	1	1	1
MOVSD xmm, xmm	1	1	1	1	1	1	1	1
MOVUPD xmm, xmm	1	1	1	1	0.33	0.5	0.5	1
MULPD xmm, xmm	3	5	5	5	0.5	0.5	0.5	1
MULSD xmm, xmm	3	5	5	5	0.5	0.5	0.5	1
ORPD xmm, xmm	1	1	1	1	0.33	1	1	1
SHUFPD xmm, xmm, imm8	1	1	1	1	1	1	1	1
SQRTPD xmm, xmm ²	18	20	20	22(21)	6	13	13	22(14)
SQRTSD xmm, xmm	18	20	20	22(21)	6	7	13	22(14)
SUBPD xmm, xmm	4	3	3	3	0.5	1	1	1

Table D-15. Streaming SIMD Extension 2 Double-precision Floating-point Instructions (Contd.)

Instruction	Latency ¹				Throughput			
	06_4E, 06_5E	06_3D/4 7/56	06_3C/4 5/46/3F	06_2A/2 D(06_3A/ 3E)	06_4E, 06_5E	06_3D/4 7/56	06_3C/4 5/46/3F	06_2A/2 D(06_3A/ 3E)
SUBSD xmm, xmm	4	3	3	3	0.5	1	1	1
UCOMISD xmm, xmm	2	2	2	2	1	1	1	1
UNPCKHPD xmm, xmm	1	1	1	1	1	1	1	1
UNPCKLPD xmm, xmm	1	1	1	1	1	1	1	1
XORPD ³ xmm, xmm	1	1	1	1	0.33	1	1	1

NOTES:

1. The latency and throughput of DIVPD/DIVSD can vary with input values. For certain values, hardware can complete quickly, throughput may be as low as ~ 6 cycles. Similarly, latency for certain input values may be as low as less than 10 cycles.
2. The latency throughput of SQRTPD/SQRTSD can vary with input value. For certain values, hardware can complete quickly, throughput may be as low as ~ 6 cycles. Similarly, latency for certain input values may be as low as less than 10 cycles.

Table D-16. Streaming SIMD Extension Single-precision Floating-point Instructions

Instruction	Latency ¹				Throughput			
	06_4E, 06_5E	06_3D/4 7/56	06_3C/4 5/46/3F	06_2A/2 D(06_3A/ 3E)	06_4E, 06_5E	06_3D/4 7/56	06_3C/4 5/46/3F	06_2A/2 D(06_3A/ 3E)
CPUID								
ADDPS xmm, xmm	4	3	3	3	0.5	1	1	1
ADDSS xmm, xmm	4	3	3	3	0.5	1	1	1
ANDNPS xmm, xmm	1	1	1	1	0.33	1	1	1
ANDPS xmm, xmm	1	1	1	1	0.33	1	1	1
CMPPS xmm, xmm	4	3	3	3	0.5	1	1	1
CMPSS xmm, xmm	4	3	3	3	0.5	1	1	1
COMISS xmm, xmm	2	2	2	2	1	1	1	1
CVTSI2SS xmm, r32	6	4	4	5	1	1	1	1
CVTSS2SI r32, xmm	6	4	4	5	1	1	1	1
CVT[T]SS2SI r64, xmm	6	4	4	5	1	1	1	1
CVTTSS2SI r32, xmm	6	4	4	5	1	1	1	1
DIVPS xmm, xmm ¹	11	<11	<13	10-14	3	4	6	14(6)
DIVSS xmm, xmm	11	<11	<13	10-14	3	2.5	6	14(6)
MAXPS xmm, xmm	4	3	3	3	0.5	1	1	1
MAXSS xmm, xmm	4	3	3	3	0.5	1	1	1
MINPS xmm, xmm	4	3	3	3	0.5	1	1	1
MINSS xmm, xmm	4	3	3	3	0.5	1	1	1
MOVAPS xmm, xmm	1	1	1	1	0.25	0.5	0.5	1
MOVHLPs xmm, xmm	1	1	1	1	1	1	1	1
MOVLHPS xmm, xmm	1	1	1	1	1	1	1	1
MOVMSKPS r64/r32, xmm	2	2	2	2	1	1	1	1

Table D-16. Streaming SIMD Extension Single-precision Floating-point Instructions (Contd.)

Instruction	Latency ¹				Throughput			
	06_4E, 06_5E	06_3D/4 7/56	06_3C/4 5/46/3F	06_2A/2 D(06_3A/ 3E)	06_4E, 06_5E	06_3D/4 7/56	06_3C/4 5/46/3F	06_2A/2 D(06_3A/ 3E)
CPUID								
MOVSS xmm, xmm	1	1	1	1	1	1	1	1
MOVUPS xmm, xmm	1	1	1	1	0.25	0.5	0.5	1
MULPS xmm, xmm	4	3	5	5	0.5	0.5	0.5	1
MULSS xmm, xmm	4	3	5	5	0.5	0.5	0.5	1
ORPS xmm, xmm	1	1	1	1	0.33	1	1	1
RCPSS xmm, xmm	4	5	5	5	1	1	1	1
RCPSS xmm, xmm	4	5	5	5	1	1	1	1
RSQRTPS xmm, xmm	4	5	5	5	1	1	1	1
RSQRTSS xmm, xmm	4	5	5	5	1	1	1	1
SHUFPS xmm, xmm, imm8	1	1	1	1	1	1	1	1
SQRTPS xmm, xmm ²	13	13	13	14	3	7	7	14(7)
SQRTSS xmm, xmm	13	13	13	14	3	4	7	14(7)
SUBPS xmm, xmm	4	3	3	3	0.5	1	1	1
SUBSS xmm, xmm	4	3	3	3	0.5	1	1	1
UCOMISS xmm, xmm	2	2	2	2	1	1	1	1
UNPCKHPS xmm, xmm	1	1	1	1	1	1	1	1
UNPCKLPS xmm, xmm	1	1	1	1	1	1	1	1
XORPS xmm, xmm	1	1	1	1	1	1	1	1
LFENCE ³					6	5	5	4
MFENCE ³					~40	~35	~35	~35
SFENCE ³					7	6	6	5
STMXCSR ³					1	1	1	1
FXSAVE ³					~90	~71	~75	~78

NOTES:

1. The latency and throughput of DIVPS/DIVSS can vary with input values. For certain values, hardware can complete quickly, throughput may be as low as ~ 6 cycles. Similarly, latency for certain input values may be as low as less than 10 cycles.
2. The latency and throughput of SQRTPS/SQRTSS can vary with input values. For certain values, hardware can complete quickly, throughput may be as low as ~ 6 cycles. Similarly, latency for certain input values may be as low as less than 10 cycles
3. The throughputs of FXSAVE/LFENCE/MFENCE/SFENCE/STMXCSR are measured with the destination in L1 Data Cache.

Table D-17. General Purpose Instructions

Instruction	Latency ¹				Throughput			
	06_4E,06_5E	06_3D/47/56	06_3C/45/46/3F	06_3A,06_3E	06_4E,06_5E	06_3D/47/56	06_3C/45/46/3F	06_3A,06_3E
ADC/SBB reg, reg	1	2	2	2	0.5	1	1	1
ADC/SBB reg, imm	1	2	2	2	0.5	1	1	1
ADD/SUB	1	1	1	1	0.25	0.25	0.25	0.33
AND/OR/XOR	1	1	1	1	0.25	0.25	0.25	0.33
BSF/BSR	3	3	3	3	1	1	1	1
BSWAP	2	2	2	2	0.5	0.5	0.5	1
BT	1	1	1	1	0.5	0.5	0.5	0.5
BTC/BTR/BTS	1	1	1	1	0.5	0.5	0.5	0.5
CBW/CWDE/CDQE	1	1	1	1	1	1	1	1
CDQ	1	1	1	1	1	1	1	1
CQO	1	1	1	1	0.5	0.5	0.5	0.5
CLC					0.25	0.33	0.33	0.33
CMC					0.25	0.33	0.33	0.33
STC					0.25	0.33	0.33	0.33
CLFLUSH ¹²					~2 to 50	~3 to 50	~3 to 50	~5 to 50
CLFLUSHOPT ¹³					~2to 10	NA	NA	NA
CMOVE/CMOVcc	1	1	2	2	0.5	0.5	0.5	0.5
CMOVBE/NBE/A/NA	2	2	3	3	1	1	1	1
CMP/TEST	1	1	1	1	0.25	0.25	0.25	0.33
CPUID (EAX = 0)					~100	~100	~100	~95
CPUID (EAX != 0)					>200	>200	>200	>200
CMPXCHG r64, r64	5	5	5	5	5	5	5	5
CMPXCHG8B m64	15	8	8	8	15	8	8	8
CMPXCHG16B m128	19	10	10	10	19	10	10	10
Lock CMPXCHG8B m64	22	19	19	24	22	19	19	24
Lock CMPXCHG16B m128	32	28	28	29	32	28	28	29
DEC/INC	1	2	2	2	0.25	0.25	0.25	0.33
IMUL r64, r64	3	3	3	3	1	1	1	1
IMUL r64 ¹⁰	4, 5	3, 4	3, 4	3, 4	1	1	1	1
IMUL r32	5	4	4	4	1	1	1	1
IDIV r64 (RDX!= 0) ⁸					~85-100	~85-100	~85-100	~85-100
IDIV r32 ⁹					~20-26	~20-26	~20-26	~19-25
LEA	1	1	1	1	0.5	0.5	0.5	0.5
LEA [base+index]disp	3	3	3	3	1	1	1	1
MOVS/BS/MOVSW	1	1	1	1	0.25	0.25	0.25	0.33
MOVZ/BS/MOVZW	1	1	1	1	0.25	0.25	0.25	0.33
DIV r64 (RDX!= 0) ⁸					~80-95	~80-95	~80-95	~80-95
DIV r32 ⁹					~20-26	~20-26	~20-26	~19-25

Table D-17. General Purpose Instructions (Contd.)

Instruction	Latency ¹				Throughput			
	06_4E,06_5E	06_3D/47/56	06_3C/45/46/3F	06_3A,06_3E	06_4E,06_5E	06_3D/47/56	06_3C/45/46/3F	06_3A,06_3E
MUL r64 ¹⁰	4, 5	3, 4	3, 4	3, 4	1	1	1	1
NEG/NOT	1	2	2	2	0.25	0.25	0.25	0.33
PAUSE					~140	~10	~10	~10
RCL/RCR reg, 1	2	2	2	2	2	1.5	1.5	1.5
RCL/RCR	6	6	6	6	6	6	6	6
RDTSC					~13	~10	~10	~20
RDTSCP					~20	~30	~30	~30
ROL/ROR reg 1	1 (2 flg)	1 (2 flg)	1 (2 flg)	1 (2 flg)	1	1	1	1
ROL/ROR reg imm	1	1	1	1	0.5	0.5	0.5	0.5
ROL/ROR reg, cl	2	2	2	2	1.5	1.5	1.5	1.5
LAHF/SAHF	3	2	2	2				
SAL/SAR/SHL/SHR reg, imm	1	1	1	1	0.5	0.5	0.5	0.5
SAL/SAR/SHL/SHR reg, cl	1.5	1.5	1.5	1.5	1.5	1.5	1.5	1.5
SETBE	2	2	2	2	1	1	1	1
SETE	1	1	1	1	0.5	0.5	0.5	0.5
SHLD/RD reg, reg, cl	6	4	4	2 (4 flg)	1.5	1	1	1.5
SHLD/RD reg, reg, imm	3	3	3	1	0.5	0.5	0.5	0.5
XSAVE ¹¹					~98	~100	~100	~100
XSAVEOPT ¹¹					~86	~90	~90	~90
XADD	2	2	2	2	1	1	1	1
XCHG reg, reg	1	1	1	2	1	1	1	1
XCHG reg, mem	22	19	19	19	22	19	19	19

D.3.2 Table Footnotes

The following footnotes refer to all tables in this appendix.

1. Latency information for many instructions that are complex (> 4 μ ops) are estimates based on conservative (worst-case) estimates. Actual performance of these instructions by the out-of-order core execution unit can range from somewhat faster to significantly faster than the latency data shown in these tables.
2. Latency and Throughput of transcendental instructions can vary substantially in a dynamic execution environment. Only an approximate value or a range of values are given for these instructions.
3. It may be possible to construct repetitive calls to some Intel 64 and IA-32 instructions in code sequences to achieve latency that is one or two clock cycles faster than the more realistic number listed in this table.
4. The FXCH instruction has 0 latency in code sequences. However, it is limited to an issue rate of one instruction per clock cycle.
5. The load constant instructions, FINCSTP, and FDECSTP have 0 latency in code sequences.
6. Selection of conditional jump instructions should be based on the recommendation of Section 3.4.1, "Branch Prediction Optimization," to improve the predictability of branches. When branches are predicted successfully, the latency of jcc is effectively zero.

7. RCL/RCR with shift count of 1 are optimized. Using RCL/RCR with shift count other than 1 will be executed more slowly. This applies to the Pentium 4 and Intel Xeon processors.
8. The throughput of "DIV/IDIV r64" varies with the number of significant digits in the input RDX:RAX. The throughput is significantly higher if RDX input is 0, similar to those of "DIV/IDIV r32". If RDX is not zero, the throughput is significantly lower, as shown in the range. The throughput decreases (increasing numerical value in cycles) with increasing number of significant bits in the input RDX:RAX (relative to the number of significant bits of the divisor) or the output quotient. The latency of "DIV/IDIV r64" also varies with the significant bits of input values. For a given set of input values, the latency is about the same as the throughput in cycles.
9. The throughput of "DIV/IDIV r32" varies with the number of significant digits in the input EDX:EAX and/or of the quotient of the division for a given size of significant bits in the divisor r32. The throughput decreases (increasing numerical value in cycles) with increasing number of significant bits in the input EDX:EAX or the output quotient. The latency of "DIV/IDIV r32" also varies with the significant bits of the input values. For a given set of input values, the latency is about the same as the throughput in cycles.
10. The latency of MUL r64 into 128-bit result has two sets of numbers, the read-to-use latency of the low 64-bit result (RAX) is smaller. The latency of the high 64-bit of the 128 bit result (RDX) is larger.
11. The throughputs of XSAVE and XSAVEOPT are measured with the destination in L1 Data Cache and includes the YMM states.
12. CLFLUSH throughput is representative from clean cache lines for a range of buffer sizes. CLFLUSH throughput can decrease significantly by factors including: (a) the number of back-to-back CLFLUSH being executed, (b) flushing modified cache lines incurs additional cost than cache lines in other coherent state. See Section 9.4.6.
13. CLFLUSHOPT throughput is representative from clean cache lines for a range of buffer sizes. CLFLUSHOPT throughput can decrease by factors including: (a) flushing modified cache lines incurs additional cost than cache lines in other coherent state, (b) the number of cache lines back-to-back. See Section 9.4.7.

D.3.3 Instructions with Memory Operands

The latency of an Instruction with memory operand can vary greatly due to a number of factors, including data locality in the memory/cache hierarchy and characteristics that are unique to each microarchitecture. Generally, software can approach tuning for locality and instruction selection independently. Thus Table D-4 through Table D-18 can be used for the purpose of instruction selection. Latency and throughput of data movement in the cache/memory hierarchy can be dealt with independent of instruction latency and throughput. Load-to-use Latency of the cache hierarchy can be found in Chapter 2.

D.3.3.1 Software Observable Latency of Memory References

When measuring latency of memory references of individual instructions, many factors can influence the observed latency exposure. Aside from access patterns, cache locality, effect of the hardware prefetchers, different microarchitectures may expose variability such register domains of the destination or memory addressing form with respect to the instruction encoding.

The table below gives a few selected sampling of the variability of L1D cache hit latency that software may observe using pointer-chasing constructs, due to memory reference encoding details, on recent Intel microarchitectures.

Table D-18. Pointer-Chasing Variability of Software Measurable Latency of L1 Data Cache Latency

Pointer Chase Construct	L1D latency Observation
MOV rax, [rax]	4
MOV rax, disp32[rax] , disp32 < 2048	4
MOV rax, [rcx+rax]	5
MOV rax, disp32[rcx+rax] , disp32 < 2048	5

APPENDIX E EARLIER GENERATIONS OF INTEL® 64 AND IA-32 PROCESSOR ARCHITECTURES

E.1 HASWELL MICROARCHITECTURE

The Haswell microarchitecture builds on the successes of the Sandy Bridge and Ivy Bridge microarchitectures. The basic pipeline functionality of the Haswell microarchitecture is depicted in Figure E-1. In general, most of the features described in Section E.1.1 - Section E.1.4 also apply to the Broadwell microarchitecture. Enhancements of the Broadwell microarchitecture are summarized in Section E.1.7.

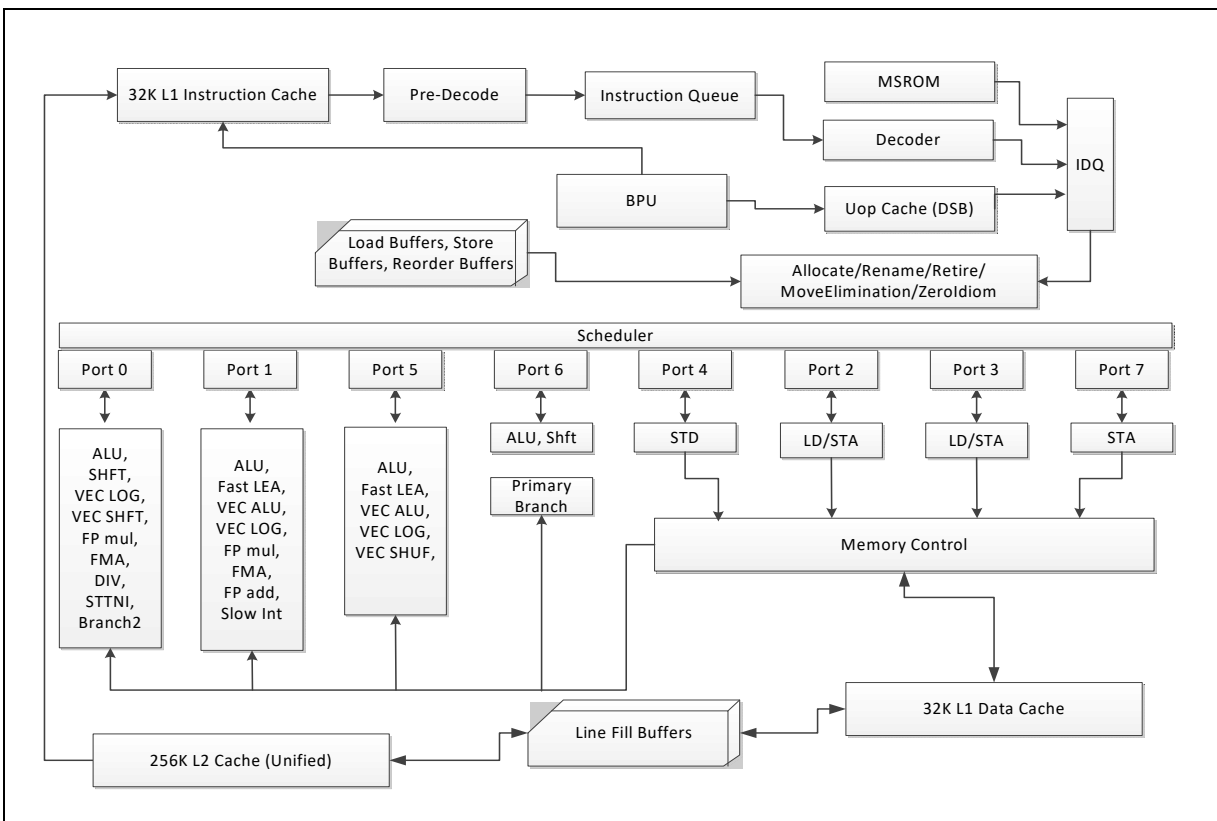

Figure E-1. CPU Core Pipeline Functionality of the Haswell Microarchitecture

The Haswell microarchitecture offers the following innovative features:

- Support for Intel Advanced Vector Extensions 2 (Intel AVX2), FMA.
- Support for general-purpose, new instructions to accelerate integer numeric encryption.
- Support for Intel® Transactional Synchronization Extensions (Intel® TSX).
- Each core can dispatch up to 8 micro-ops per cycle.
- 256-bit data path for memory operation, FMA, AVX floating-point and AVX2 integer execution units.
- Improved L1D and L2 cache bandwidth.
- Two FMA execution pipelines.
- Four arithmetic logical units (ALUs).

- Three store address ports.
- Two branch execution units.
- Advanced power management features for IA processor core and uncore sub-systems.
- Support for optional fourth level cache.

The microarchitecture supports flexible integration of multiple processor cores with a shared uncore sub-system consisting of a number of components including a ring interconnect to multiple slices of L3 (an off-die L4 is optional), processor graphics, integrated memory controller, interconnect fabrics, etc. An example of the system integration view of four CPU cores with uncore components is illustrated in Figure E-2.

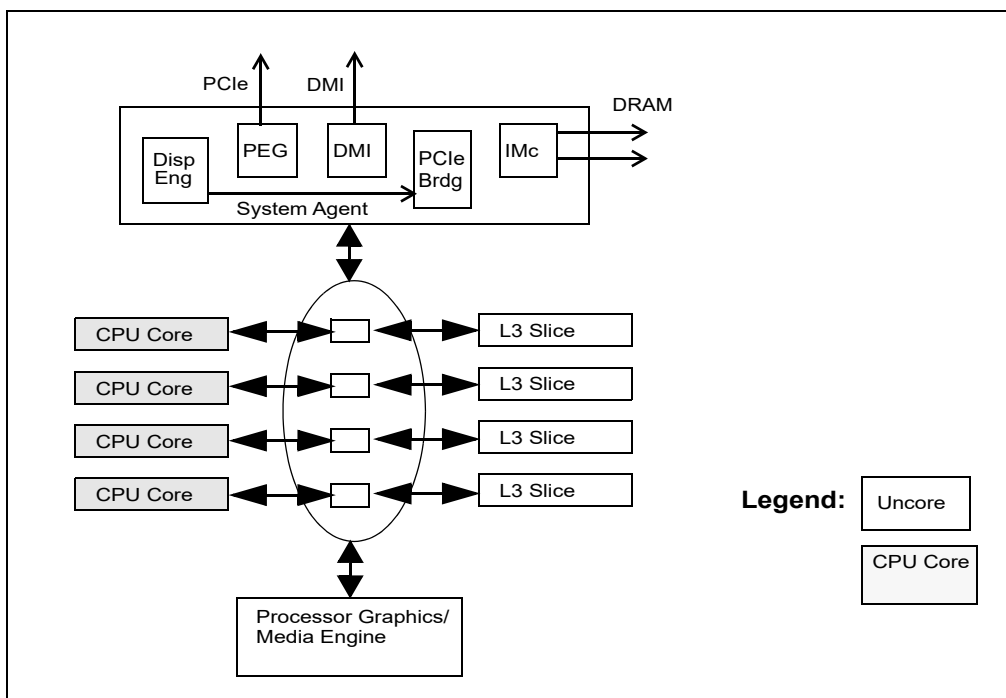

Figure E-2. Four Core System Integration of the Haswell Microarchitecture

E.1.1 The Front End

The front end of Haswell microarchitecture builds on that of the Sandy Bridge and Ivy Bridge microarchitectures, see Section E.2.2 and Section E.2.7. Additional enhancements in the front end include:

- The uop cache (or decoded ICache) is partitioned equally between two logical processors.
- The instruction decoders will alternate between each active logical processor. If one sibling logical processor is idle, the active logical processor will use the decoders continuously.
- The LSD in the micro-op queue (or IDQ) can detect small loops up to 56 micro-ops. The 56-entry micro-op queue is shared by two logical processors if Hyper-Threading Technology is active (Sandy Bridge microarchitecture provides duplicated 28-entry micro-op queue in each core).

E.1.2 The Out-of-Order Engine

The key components and significant improvements to the out-of-order engine are summarized below:

Renamer: The Renamer moves micro-ops from the micro-op queue to bind to the dispatch ports in the Scheduler with execution resources. Zero-idiom, one-idiom and zero-latency register move operations are performed by the Renamer to free up the Scheduler and execution core for improved performance.

Scheduler: The Scheduler controls the dispatch of micro-ops onto the dispatch ports. There are eight dispatch ports to support the out-of-order execution core. Four of the eight ports provided execution resources for computational operations. The other 4 ports support memory operations of up to two 256-bit load and one 256-bit store operation in a cycle.

Execution Core: The scheduler can dispatch up to eight micro-ops every cycle, one on each port. Of the four ports providing computational resources, each provides an ALU, two of these execution pipes provided dedicated FMA units. With the exception of division/square-root, STTNI/AESNI units, most floating-point and integer SIMD execution units are 256-bit wide. The four dispatch ports servicing memory operations consist with two dual-use ports for load and store-address operation. Plus a dedicated 3rd store-address port and one dedicated store-data port. All memory ports can handle 256-bit memory micro-ops. Peak floating-point throughput, at 32 single-precision operations per cycle and 16 double-precision operations per cycle using FMA, is twice that of Sandy Bridge microarchitecture.

The out-of-order engine can handle 192 uops in flight compared to 168 in Sandy Bridge microarchitecture.

E.1.3 Execution Engine

Table E-1 summarizes which operations can be dispatched on which port.

Table E-1. Dispatch Port and Execution Stacks of the Haswell Microarchitecture

Port 0	Port 1	Port 2, 3	Port 4	Port 5	Port 6	Port 7
ALU, Shift	ALU, Fast LEA, BM	Load_Addr, Store_addr	Store_data	ALU, Fast LEA, BM	ALU, Shift, JEU	Store_addr, Simple_AGU
SIMD_Log, SIMD_misc, SIMD_Shifts	SIMD_ALU, SIMD_Log			SIMD_ALU, SIMD_Log,		
FMA/FP_mul, Divide	FMA/FP_mul, FP_add			Shuffle		
2nd_Jeu	slow_int,			FP mov, AES		

Table E-2 lists execution units and common representative instructions that rely on these units. Table E-2 also includes some instructions that are available only on processors based on the Broadwell microarchitecture.

Table E-2. Haswell Microarchitecture Execution Units and Representative Instructions

Execution Unit	# of Ports	Instructions
ALU	4	add, and, cmp, or, test, xor, movzx, movsx, mov, (v)movdqu, (v)movdqa
SHFT	2	sal, shl, rol, adc, sarx, (adcx, adox) ¹ etc.
Slow Int	1	mul, imul, bsr, rcl, shld, mulx, pdep, etc.
BM	2	andn, bextr, blsi, blmsk, bzhi, etc
SIMD Log	3	(v)pand, (v)por, (v)pxor, (v)movq, (v)movq, (v)blendp*, vpblendd
SIMD_Shft	1	(v)psl*, (v)psr*
SIMD ALU	2	(v)padd*, (v)psign, (v)pabs, (v)pavgb, (v)pcmpeq*, (v)pmax, (v)pcmpgt*
Shuffle	1	(v)shufp*, vperm*, (v)pack*, (v)unpck*, (v)punpck*, (v)pshuf*, (v)pslldq, (v)alignr, (v)pmovzx*, vbroadcast*, (v)pslldq, (v)pblendw
SIMD Misc	1	(v)pmul*, (v)pmadd*, STTNI, (v)pclmulqdq, (v)psadw, (v)pcmpgtq, vpsllvd, (v)bendv*, (v)plendw,
FP Add	1	(v)addp*, (v)cmpp*, (v)max*, (v)min*,
FP Mov	1	(v)movap*, (v)movup*, (v)movsd/ss, (v)movd gpr, (v)andp*, (v)orcp*
DIVIDE	1	divp*, divs*, vdiv*, sqrt*, vsqrt*, rcp*, vrcp*, rsqrt*, idiv

NOTES:

1. Only available in processors based on the Broadwell microarchitecture and support CPUID ADX feature flag.

The reservation station (RS) is expanded to 60 entries deep (compared to 54 entries in Sandy Bridge microarchitecture). It can dispatch up to eight micro-ops in one cycle if the micro-ops are ready to execute. The RS dispatch a micro-op through an issue port to a specific execution cluster, arranged in several stacks to handle specific data types or granularity of data.

When a source of a micro-op executed in one stack comes from a micro-op executed in another stack, a delay can occur. The delay occurs also for transitions between Intel SSE integer and Intel SSE floating-point operations. In some of the cases the data transition is done using a micro-op that is added to the instruction flow. Table E-25 describes how data, written back after execution, can bypass to micro-op execution in the following cycles.

Table E-3. Bypass Delay Between Producer and Consumer Micro-ops (cycles)

From/To	INT	SSE-INT/ AVX-INT	SSE-FP/ AVX-FP_LOW	X87/ AVX-FP_High
INT		<ul style="list-style-type: none"> micro-op (port 5) micro-op (port 6) + 1 cycle 	<ul style="list-style-type: none"> micro-op (port 5) micro-op (port 6) + 1 cycle 	micro-op (port 5) + 3 cycle delay
SSE-INT/ AVX-INT	micro-op (port 1)		1 cycle delay	
SSE-FP/ AVX-FP_LOW	micro-op (port 1)	1 cycle delay		micro-op (port 5) + 1 cycle delay
X87/ AVX-FP_High	micro-op (port 1) + 3 cycle delay		micro-op (port 5) + 1 cycle delay	
Load		1 cycle delay	1 cycle delay	2 cycle delay

E.1.4 Cache and Memory Subsystem

The cache hierarchy is similar to prior generations, including an instruction cache, a first-level data cache and a second-level unified cache in each core, and a 3rd-level unified cache with size dependent on specific product configuration. The 3rd-level cache is organized as multiple cache slices, the size of each slice may depend on product configurations, connected by a ring interconnect. The exact details of the cache topology is reported by CPUID leaf 4. The 3rd level cache resides in the “uncore” sub-system that is shared by all the processor cores. In some product configurations, a fourth level cache is also supported. Table E-23 provides more details of the cache hierarchy.

Table E-4. Cache Parameters of the Haswell Microarchitecture

Level	Capacity / Associativity	Line Size (bytes)	Fastest Latency ¹	Throughput (clocks)	Peak Bandwidth (bytes/cyc)	Update Policy
First Level Data	32 KB/ 8	64	4 cycle	0.5 ²	64 (Load) + 32 (Store)	Writeback
Instruction	32 KB/8	64	N/A	N/A	N/A	N/A
Second Level	256KB/8	64	11 cycle	Varies	64	Writeback
Third Level (Shared L3)	Varies	64	~ ³⁴	Varies		Writeback

NOTES:

1. Software-visible latency will vary depending on access patterns and other factors. L3 latency can vary due to clock ratios between the processor core and uncore.
2. First level data cache supports two load micro-ops each cycle; each micro-op can fetch up to 32-bytes of data.

The TLB hierarchy consists of dedicated level one TLB for instruction cache, TLB for L1D, plus unified TLB for L2.

Table E-5. TLB Parameters of the Haswell Microarchitecture

Level	Page Size	Entries	Associativity	Partition
Instruction	4KB	128	4 ways	dynamic
Instruction	2MB/4MB	8 per thread		fixed
First Level Data	4KB	64	4	fixed
First Level Data	2MB/4MB	32	4	fixed
First Level Data	1GB	4	4	fixed
Second Level	Shared by 4KB and 2/4MB pages	1024	8	fixed

E.1.4.1 Load and Store Operation Enhancements

The L1 data cache can handle two 256-bit load and one 256-bit store operations each cycle. The unified L2 can service one cache line (64 bytes) each cycle. Additionally, there are 72 load buffers and 42 store buffers available to support micro-ops execution in-flight.

E.1.5 Unlamination

Some micro-fused instructions cannot be allocated as a single uop, and therefore they break into two uops in the micro-op queue. The process of breaking a fused instruction into its uops is called unlamination.

Unlamination will take place if the number of fused instruction sources is greater than three.

Instruction sources in the context of unlamination are considered to be one of the following: memory address base, memory address index, source register, destination register (including flags), or a source and destination register.

A memory operand in the context of unlamination can have up to two sources. A memory address in the x86 instruction set is constructed from: $\text{base} + \text{index} * \text{scale} + \text{displacement}$.

Only a base and an index are counted as instruction sources. Notice that if an index exists, the base is counted as a source even if it's not present.

In addition, source and destination registers are counted as two sources; this is also true in the case where the source and destination register are the same.

The following table shows examples of micro-fused instructions and details of unlamination.

Table E-6. Components of the Front End

Instruction Example	Source	Destination	Source and Destination	Index	Base	Number of Sources ¹	Unlaminated
mulss xmm1, [4*rax+100]	-	-	xmm1	rax	0	3	no
vmulss xmm1, xmm1, [rax +100]	xmm1	xmm1	-	-	rax	3	no
vmulss xmm1, xmm1, [4*rax+100]	xmm1	xmm1	-	rax	0	4	yes
cmp rax, [rbx+4*rax+4]	rax	flags	-	rax	rbx	4	yes
cmp rax, [rbx+4]	rax	flags	-	-	rbx	3	no

NOTES:

1. Recommendation: to avoid unlamination, keep the number of micro-fused instruction sources under 4.

E.1.6 Haswell-E Microarchitecture

Intel processors based on the Haswell-E microarchitecture comprises the same processor cores as described in the Haswell microarchitecture, but provides more advanced uncore and integrated I/O capabilities. Processors based on the Haswell-E microarchitecture support platforms with multiple sockets.

The Haswell-E microarchitecture supports versatile processor architectures and platform configurations for scalability and high performance. Some of capabilities provided by the uncore and integrated I/O sub-system of the Haswell-E microarchitecture include:

- Support for multiple Intel QPI interconnects in multi-socket configurations.
- Up to two integrated memory controllers per physical processor.
- Up to 40 lanes of PCI Express* 3.0 links per physical processor.
- Up to 18 processor cores connected by two ring interconnects to the L3 in each physical processor.

An example of a possible 12-core processor implementation using the Haswell-E microarchitecture is illustrated in Figure E-3. The capabilities of the uncore and integrated I/O sub-system vary across the processor family implementing the Haswell-E microarchitecture. For details, please consult the data sheets of respective Intel Xeon E5 v3 processors.

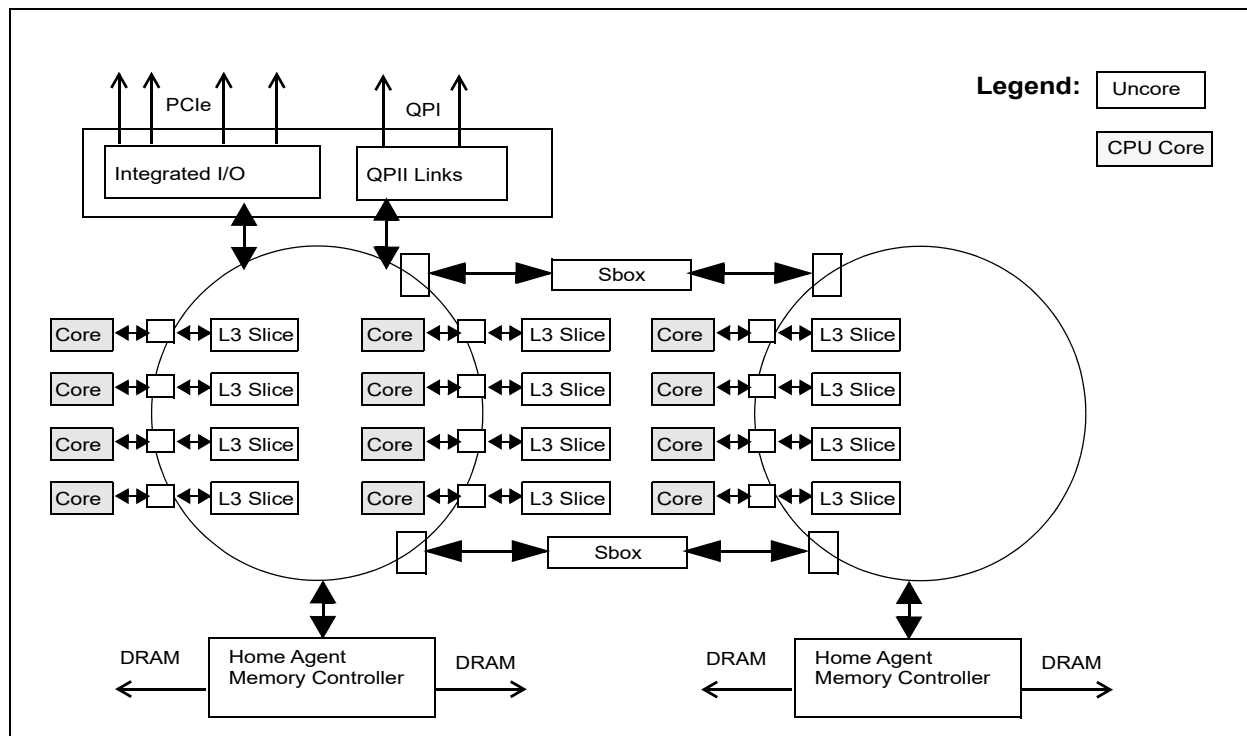

Figure E-3. An Example of the Haswell-E Microarchitecture Supporting 12 Processor Cores

E.1.7 Broadwell Microarchitecture

Intel Core M processors are based on the Broadwell microarchitecture. The Broadwell microarchitecture builds from the Haswell microarchitecture and provides several enhancements. This section covers enhanced features of the Broadwell microarchitecture.

- Floating-point multiply instruction latency is improved from 5 cycles in prior generation to 3 cycle in the Broadwell microarchitecture. This applies to AVX, SSE and FP instruction sets.
- The throughput of gather instructions has been improved significantly, see Table D-5.
- The PCLMULQDQ instruction implementation is a single uop in the Broadwell microarchitecture with improved latency and throughput.

The TLB hierarchy consists of dedicated level one TLB for instruction cache, TLB for L1D, plus unified TLB for L2.

Table E-7. TLB Parameters of the Broadwell Microarchitecture

Level	Page Size	Entries	Associativity	Partition
Instruction	4KB	128	4 ways	dynamic
Instruction	2MB/4MB	8 per thread		fixed
First Level Data	4KB	64	4	fixed
First Level Data	2MB/4MB	32	4	fixed
First Level Data	1GB	4	4	fixed
Second Level	Shared by 4KB and 2MB pages	1536	6	fixed
Second Level	1GB pages	16	4	fixed

E.2 SANDY BRIDGE MICROARCHITECTURE

Sandy Bridge microarchitecture builds on the successes of Intel® Core™ microarchitecture and Nehalem microarchitecture. It offers the following innovative features:

- Intel Advanced Vector Extensions (Intel AVX)
 - 256-bit floating-point instruction set extensions to the 128-bit Intel Streaming SIMD Extensions, providing up to 2X performance benefits relative to 128-bit code.
 - Non-destructive destination encoding offers more flexible coding techniques.
 - Supports flexible migration and co-existence between 256-bit AVX code, 128-bit AVX code and legacy 128-bit SSE code.
- Enhanced front end and execution engine
 - New decoded ICache component that improves front end bandwidth and reduces branch misprediction penalty.
 - Advanced branch prediction.
 - Additional macro-fusion support.
 - Larger dynamic execution window.
 - Multi-precision integer arithmetic enhancements (ADC/SBB, MUL/IMUL).
 - LEA bandwidth improvement.
 - Reduction of general execution stalls (read ports, writeback conflicts, bypass latency, partial stalls).
 - Fast floating-point exception handling.
 - XSAVE/XRSTORE performance improvements and XSAVEOPT new instruction.
- Cache hierarchy improvements for wider data path
 - Doubling of bandwidth enabled by two symmetric ports for memory operation.
 - Simultaneous handling of more in-flight loads and stores enabled by increased buffers.
 - Internal bandwidth of two loads and one store each cycle.
 - Improved prefetching.
 - High bandwidth low latency LLC architecture.
 - High bandwidth ring architecture of on-die interconnect.
- System-on-a-chip support

- Integrated graphics and media engine in second generation Intel Core processors.
- Integrated PCIE controller.
- Integrated memory controller.
- Next generation Intel Turbo Boost Technology
 - Leverage TDP headroom to boost performance of CPU cores and integrated graphic unit.

E.2.1 Sandy Bridge Microarchitecture Pipeline Overview

Figure E-4 depicts the pipeline and major components of a processor core that's based on Sandy Bridge microarchitecture. The pipeline consists of:

- An in-order issue front end that fetches instructions and decodes them into micro-ops (micro-operations). The front end feeds the next pipeline stages with a continuous stream of micro-ops from the most likely path that the program will execute.
- An out-of-order, superscalar execution engine that dispatches up to six micro-ops to execution, per cycle. The allocate/rename block reorders micro-ops to "dataflow" order so they can execute as soon as their sources are ready and execution resources are available.
- An in-order retirement unit that ensures that the results of execution of the micro-ops, including any exceptions they may have encountered, are visible according to the original program order.

The flow of an instruction in the pipeline can be summarized in the following progression:

1. The Branch Prediction Unit chooses the next block of code to execute from the program. The processor searches for the code in the following resources, in this order:
 - a. Decoded ICache.
 - b. Instruction Cache, via activating the legacy decode pipeline.
 - c. L2 cache, last level cache (LLC) and memory, as necessary.

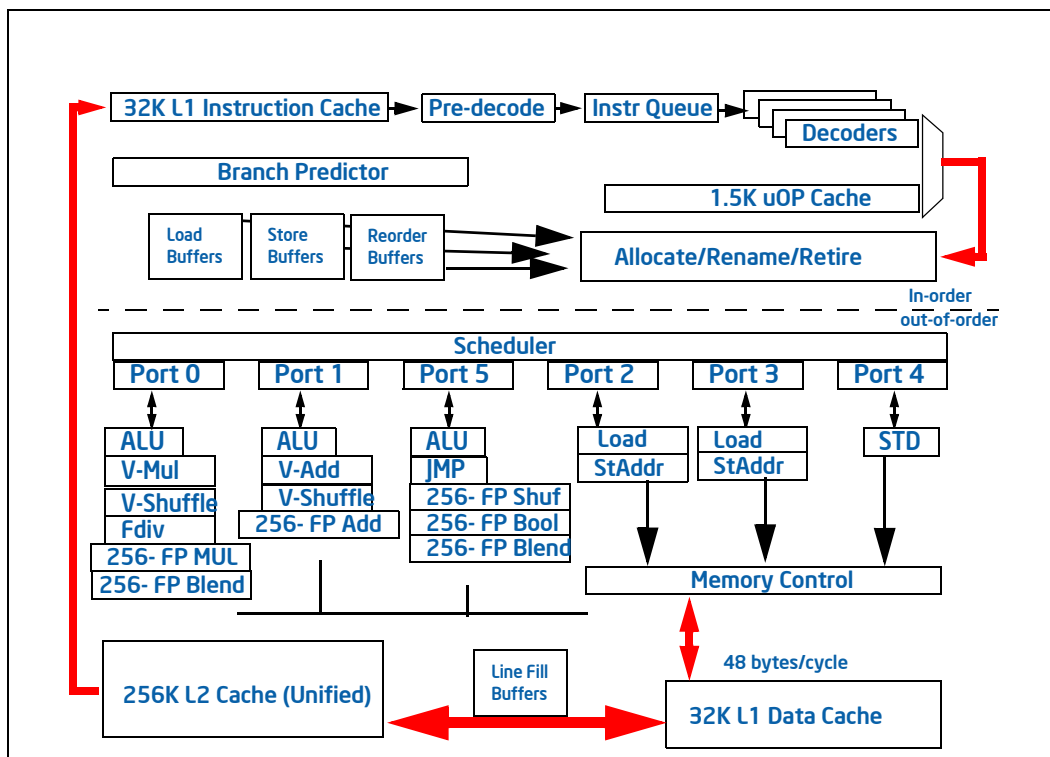

Figure E-4. Sandy Bridge Microarchitecture Pipeline Functionality

2. The micro-ops corresponding to this code are sent to the Rename/retirement block. They enter into the scheduler in program order, but execute and are de-allocated from the scheduler according to data-flow order. For simultaneously ready micro-ops, FIFO ordering is nearly always maintained.
Micro-op execution is executed using execution resources arranged in three stacks. The execution units in each stack are associated with the data type of the instruction.
Branch mispredictions are signaled at branch execution. It re-steers the front end which delivers micro-ops from the correct path. The processor can overlap work preceding the branch misprediction with work from the following corrected path.
3. Memory operations are managed and reordered to achieve parallelism and maximum performance. Misses to the L1 data cache go to the L2 cache. The data cache is non-blocking and can handle multiple simultaneous misses.
4. Exceptions (Faults, Traps) are signaled at retirement (or attempted retirement) of the faulting instruction.

Each processor core based on Sandy Bridge microarchitecture can support two logical processor if Intel Hyper-Threading Technology is enabled.

E.2.2 The Front End

This section describes the key characteristics of the front end. Table E-8 lists the components of the front end, their functions, and the problems they address.

Table E-8. Components of the Front End of Sandy Bridge Microarchitecture

Component	Functions	Performance Challenges
Instruction Cache	32-Kbyte backing store of instruction bytes	Fast access to hot code instruction bytes
Legacy Decode Pipeline	Decode instructions to micro-ops, delivered to the micro-op queue and the Decoded ICache.	Provides the same decode latency and bandwidth as prior Intel processors. Decoded ICache warm-up
Decoded ICache	Provide stream of micro-ops to the micro-op queue.	Provides higher micro-op bandwidth at lower latency and lower power than the legacy decode pipeline
MSROM	Complex instruction micro-op flow store, accessible from both Legacy Decode Pipeline and Decoded ICache	
Branch Prediction Unit (BPU)	Determine next block of code to be executed and drive lookup of Decoded ICache and legacy decode pipelines.	Improves performance and energy efficiency through reduced branch mispredictions.
Micro-op queue	Queues micro-ops from the Decoded ICache and the legacy decode pipeline.	Hide front end bubbles; provide execution micro-ops at a constant rate.

E.2.2.1 Legacy Decode Pipeline

The Legacy Decode Pipeline comprises the instruction translation lookaside buffer (ITLB), the instruction cache (ICache), instruction predecode, and instruction decode units.

Instruction Cache and ITLB

An instruction fetch is a 16-byte aligned lookup through the ITLB and into the instruction cache. The instruction cache can deliver every cycle 16 bytes to the instruction pre-decoder. Table E-8 compares the ICache and ITLB with prior generation.

Table E-9. ICache and ITLB of Sandy Bridge Microarchitecture

Component	Sandy Bridge Microarchitecture	Nehalem Microarchitecture
ICache Size	32-Kbyte	32-Kbyte
ICache Ways	8	4
ITLB 4K page entries	128	128
ITLB large page (2M or 4M) entries	8	7

Upon ITLB miss there is a lookup to the Second level TLB (STLB) that is common to the DTLB and the ITLB. The penalty of an ITLB miss and a STLB hit is seven cycles.

Instruction PreDecode

The predecode unit accepts the 16 bytes from the instruction cache and determines the length of the instructions.

The following length changing prefixes (LCPs) imply instruction length that is different from the default length of instructions. Therefore they cause an additional penalty of three cycles per LCP during length decoding. Previous processors incur a six-cycle penalty for each 16-byte chunk that has one or more LCPs in it. Since usually there is no more than one LCP in a 16-byte chunk, in most cases, Sandy Bridge microarchitecture introduces an improvement over previous processors.

- Operand Size Override (66H) preceding an instruction with a word/double immediate data. This prefix might appear when the code uses 16 bit data types, unicode processing, and image processing.
- Address Size Override (67H) preceding an instruction with a modr/m in real, big real, 16-bit protected or 32-bit protected modes. This prefix may appear in boot code sequences.
- The REX prefix (4xh) in the Intel® 64 instruction set can change the size of two classes of instructions: MOV offset and MOV immediate. Despite this capability, it does not cause an LCP penalty and hence is not considered an LCP.

Instruction Decode

There are four decoding units that decode instruction into micro-ops. The first can decode all IA-32 and Intel 64 instructions up to four micro-ops in size. The remaining three decoding units handle single-micro-op instructions. All four decoding units support the common cases of single micro-op flows including micro-fusion and macro-fusion.

Micro-ops emitted by the decoders are directed to the micro-op queue and to the Decoded ICache. Instructions longer than four micro-ops generate their micro-ops from the MSR0M. The MSR0M bandwidth is four micro-ops per cycle. Instructions whose micro-ops come from the MSR0M can start from either the legacy decode pipeline or from the Decoded ICache.

MicroFusion

Micro-fusion fuses multiple micro-ops from the same instruction into a single complex micro-op. The complex micro-op is dispatched in the out-of-order execution core as many times as it would if it were not micro-fused.

Micro-fusion enables you to use memory-to-register operations, also known as the complex instruction set computer (CISC) instruction set, to express the actual program operation without worrying about a loss of decode bandwidth. Micro-fusion improves instruction bandwidth delivered from decode to retirement and saves power.

Coding an instruction sequence by using single-uop instructions will increase the code size, which can decrease fetch bandwidth from the legacy pipeline.

The following are examples of micro-fused micro-ops that can be handled by all decoders.

- All stores to memory, including store immediate. Stores execute internally as two separate functions, store-address and store-data.

- All instructions that combine load and computation operations (load+op), for example:
 - ADDPS XMM9, QWORD PTR [RSP+40]
 - FADD DOUBLE PTR [RDI+RSI*8]
 - XOR RAX, QWORD PTR [RBP+32]
- All instructions of the form "load and jump," for example:
 - JMP [RDI+200]
 - RET
- CMP and TEST with immediate operand and memory

An instruction with RIP relative addressing is not micro-fused in the following cases:

- An additional immediate is needed, for example:
 - CMP [RIP+400], 27
 - MOV [RIP+3000], 142
- The instruction is a control flow instruction with an indirect target specified using RIP-relative addressing, for example:
 - JMP [RIP+5000000]

In these cases, an instruction that can not be micro-fused will require decoder 0 to issue two micro-ops, resulting in a slight loss of decode bandwidth.

In 64-bit code, the usage of RIP Relative addressing is common for global data. Since there is no micro-fusion in these cases, performance may be reduced when porting 32-bit code to 64-bit code.

Macro-Fusion

Macro-fusion merges two instructions into a single micro-op. In Intel Core microarchitecture, this hardware optimization is limited to specific conditions specific to the first and second of the macro-fusable instruction pair.

- The first instruction of the macro-fused pair modifies the flags. The following instructions can be macro-fused:
 - In Nehalem microarchitecture: CMP, TEST.
 - In Sandy Bridge microarchitecture: CMP, TEST, ADD, SUB, AND, INC, DEC
 - These instructions can fuse if
 - The first source / destination operand is a register.
 - The second source operand (if exists) is one of: immediate, register, or non RIP-relative memory.
- The second instruction of the macro-fusable pair is a conditional branch. Table 3-1 describes, for each instruction, what branches it can fuse with.

Macro fusion does not happen if the first instruction ends on byte 63 of a cache line, and the second instruction is a conditional branch that starts at byte 0 of the next cache line.

Since these pairs are common in many types of applications, macro-fusion improves performance even on non-recompiled binaries.

Each macro-fused instruction executes with a single dispatch. This reduces latency and frees execution resources. You also gain increased rename and retire bandwidth, increased virtual storage, and power savings from representing more work in fewer bits.

E.2.2.2 Decoded ICache

The Decoded ICache is essentially an accelerator of the legacy decode pipeline. By storing decoded instructions, the Decoded ICache enables the following features:

- Reduced latency on branch mispredictions.

- Increased micro-op delivery bandwidth to the out-of-order engine.
- Reduced front end power consumption.

The Decoded ICache caches the output of the instruction decoder. The next time the micro-ops are consumed for execution the decoded micro-ops are taken from the Decoded ICache. This enables skipping the fetch and decode stages for these micro-ops and reduces power and latency of the Front End. The Decoded ICache provides average hit rates of above 80% of the micro-ops; furthermore, "hot spots" typically have hit rates close to 100%.

Typical integer programs average less than four bytes per instruction, and the front end is able to race ahead of the back end, filling in a large window for the scheduler to find instruction level parallelism. However, for high performance code with a basic block consisting of many instructions, for example, Intel SSE media algorithms or excessively unrolled loops, the 16 instruction bytes per cycle is occasionally a limitation. The 32-byte orientation of the Decoded ICache helps such code to avoid this limitation.

The Decoded ICache automatically improves performance of programs with temporal and spatial locality. However, to fully utilize the Decoded ICache potential, you might need to understand its internal organization.

The Decoded ICache consists of 32 sets. Each set contains eight Ways. Each Way can hold up to six micro-ops. The Decoded ICache can ideally hold up to 1536 micro-ops.

The following are some of the rules how the Decoded ICache is filled with micro-ops:

- All micro-ops in a Way represent instructions which are statically contiguous in the code and have their EIPs within the same aligned 32-byte region.
- Up to three Ways may be dedicated to the same 32-byte aligned chunk, allowing a total of 18 micro-ops to be cached per 32-byte region of the original IA program.
- A multi micro-op instruction cannot be split across Ways.
- Up to two branches are allowed per Way.
- An instruction which turns on the MSR0M consumes an entire Way.
- A non-conditional branch is the last micro-op in a Way.
- Micro-fused micro-ops (load+op and stores) are kept as one micro-op.
- A pair of macro-fused instructions is kept as one micro-op.
- Instructions with 64-bit immediate require two slots to hold the immediate.

When micro-ops cannot be stored in the Decoded ICache due to these restrictions, they are delivered from the legacy decode pipeline. Once micro-ops are delivered from the legacy pipeline, fetching micro-ops from the Decoded ICache can resume only after the next branch micro-op. Frequent switches can incur a penalty.

The Decoded ICache is virtually included in the Instruction cache and ITLB. That is, any instruction with micro-ops in the Decoded ICache has its original instruction bytes present in the instruction cache. Instruction cache evictions must also be evicted from the Decoded ICache, which evicts only the necessary lines.

There are cases where the entire Decoded ICache is flushed. One reason for this can be an ITLB entry eviction. Other reasons are not usually visible to the application programmer, as they occur when important controls are changed, for example, mapping in CR3, or feature and mode enabling in CR0 and CR4. There are also cases where the Decoded ICache is disabled, for instance, when the CS base address is NOT set to zero.

E.2.2.3 Branch Prediction

Branch prediction predicts the branch target and enables the processor to begin executing instructions long before the branch true execution path is known. All branches utilize the branch prediction unit (BPU) for prediction. This unit predicts the target address not only based on the EIP of the branch but also based on the execution path through which execution reached this EIP. The BPU can efficiently predict the following branch types:

- Conditional branches.

- Direct calls and jumps.
- Indirect calls and jumps.
- Returns.

E.2.2.4 Micro-op Queue and the Loop Stream Detector (LSD)

The micro-op queue decouples the front end and the out-of order engine. It stays between the micro-op generation and the renamer as shown in Figure E-4. This queue helps to hide bubbles which are introduced between the various sources of micro-ops in the front end and ensures that four micro-ops are delivered for execution, each cycle.

The micro-op queue provides post-decode functionality for certain instructions types. In particular, loads combined with computational operations and all stores, when used with indexed addressing, are represented as a single micro-op in the decoder or Decoded ICache. In the micro-op queue they are fragmented into two micro-ops through a process called un-lamination, one does the load and the other does the operation. A typical example is the following "load plus operation" instruction:

```
ADD          RAX, [RBP+RSI]; rax := rax + LD( RBP+RSI )
```

Similarly, the following store instruction has three register sources and is broken into "generate store address" and "generate store data" sub-components.

```
MOV          [ESP+ECX*4+12345678], AL
```

The additional micro-ops generated by unlamination use the rename and retirement bandwidth. However, it has an overall power benefit. For code that is dominated by indexed addressing (as often happens with array processing), recoding algorithms to use base (or base+displacement) addressing can sometimes improve performance by keeping the load plus operation and store instructions fused.

The Loop Stream Detector (LSD)

The Loop Stream Detector was introduced in Intel® Core microarchitectures. The LSD detects small loops that fit in the micro-op queue and locks them down. The loop streams from the micro-op queue, with no more fetching, decoding, or reading micro-ops from any of the caches, until a branch mis-prediction inevitably ends it.

The loops with the following attributes qualify for LSD/micro-op queue replay:

- Up to eight chunk fetches of 32-instruction-bytes.
- Up to 28 micro-ops (~28 instructions).
- All micro-ops are also resident in the Decoded ICache.
- Can contain no more than eight taken branches and none of them can be a CALL or RET.
- Cannot have mismatched stack operations. For example, more PUSH than POP instructions.

Many calculation-intensive loops, searches and software string moves match these characteristics.

Use the loop cache functionality opportunistically. For high performance code, loop unrolling is generally preferable for performance even when it overflows the LSD capability.

E.2.3 The Out-of-Order Engine

The Out-of-Order engine provides improved performance over prior generations with excellent power characteristics. It detects dependency chains and sends them to execution out-of-order while maintaining the correct data flow. When a dependency chain is waiting for a resource, such as a second-level data cache line, it sends micro-ops from another chain to the execution core. This increases the overall rate of instructions executed per cycle (IPC).

The out-of-order engine consists of two blocks, shown in Figure E-4: Core Functional Diagram, the Rename/retirement block, and the Scheduler.

The Out-of-Order engine contains the following major components:

Renamer. The Renamer component moves micro-ops from the front end to the execution core. It eliminates false dependencies among micro-ops, thereby enabling out-of-order execution of micro-ops.

Scheduler. The Scheduler component queues micro-ops until all source operands are ready. Schedules and dispatches ready micro-ops to the available execution units in as close to a first in first out (FIFO) order as possible.

Retirement. The Retirement component retires instructions and micro-ops in order and handles faults and exceptions.

E.2.3.1 Renamer

The Renamer is the bridge between the in-order part in Figure E-4, and the dataflow world of the Scheduler. It moves up to four micro-ops every cycle from the micro-op queue to the out-of-order engine.

Although the renamer can send up to 4 micro-ops (unfused, micro-fused, or macro-fused) per cycle, this is equivalent to the issue port can dispatch six micro-ops per cycle. In this process, the out-of-order core carries out the following steps:

- Renames architectural sources and destinations of the micro-ops to micro-architectural sources and destinations.
- Allocates resources to the micro-ops. For example, load or store buffers.
- Binds the micro-op to an appropriate dispatch port.

Some micro-ops can execute to completion during rename and are removed from the pipeline at that point, effectively costing no execution bandwidth. These include:

- Zero idioms (dependency breaking idioms).
- NOP.
- VZEROUPPER.
- FXCHG.

The renamer can allocate two branches each cycle, compared to one branch each cycle in the previous microarchitecture. This can eliminate some bubbles in execution.

Micro-fused load and store operations that use an index register are decomposed to two micro-ops, hence consume two out of the four slots the Renamer can use every cycle.

Dependency Breaking Idioms

Instruction parallelism can be improved by using common instructions to clear register contents to zero. The renamer can detect them on the zero evaluation of the destination register.

Use one of these dependency breaking idioms to clear a register when possible.

- XOR REG,REG
- SUB REG,REG
- PXOR/VPXOR XMMREG,XMMREG
- PSUBB/W/D/Q XMMREG,XMMREG
- VPSUBB/W/D/Q XMMREG,XMMREG
- XORPS/PD XMMREG,XMMREG
- VXORPS/PD YMMREG, YMMREG

Since zero idioms are detected and removed by the renamer, they have no execution latency.

There is another dependency breaking idiom - the "ones idiom".

- CMPEQ XMM1, XMM1; "ones idiom" set all elements to all "ones"

In this case, the micro-op must execute, however, since it is known that regardless of the input data the output data is always "all ones" the micro-op dependency upon its sources does not exist as with the zero idiom and it can execute as soon as it finds a free execution port.

E.2.3.2 Scheduler

The scheduler controls the dispatch of micro-ops onto their execution ports. In order to do this, it must identify which micro-ops are ready and where its sources come from: a register file entry, or a bypass directly from an execution unit. Depending on the availability of dispatch ports and writeback buses, and the priority of ready micro-ops, the scheduler selects which micro-ops are dispatched every cycle.

E.2.4 The Execution Core

The execution core is superscalar and can process instructions out of order. The execution core optimizes overall performance by handling the most common operations efficiently, while minimizing potential delays.

The out-of-order execution core improves execution unit organization over prior generation in the following ways:

- Reduction in read port stalls.
- Reduction in writeback conflicts and delays.
- Reduction in power.
- Reduction of SIMD FP assists dealing with denormal inputs and underflow outputs.

Some high precision FP algorithms need to operate with FTZ=0 and DAZ=0, i.e. permitting underflow intermediate results and denormal inputs to achieve higher numerical precision at the expense of reduced performance on prior generation microarchitectures due to SIMD FP assists. The reduction of SIMD FP assists in Sandy Bridge microarchitecture applies to the following SSE instructions (and AVX variants): ADDPD/ADDPS, MULPD/MULPS, DIVPD/DIVPS, and CVTPD2PS.

The out-of-order core consist of three execution stacks, where each stack encapsulates a certain type of data. The execution core contains the following execution stacks:

- General purpose integer.
- SIMD integer and floating-point.
- X87.

The execution core also contains connections to and from the cache hierarchy. The loaded data is fetched from the caches and written back into one of the stacks.

The scheduler can dispatch up to six micro-ops every cycle, one on each port. The following table summarizes which operations can be dispatched on which port.

Table E-10. Dispatch Port and Execution Stacks

	Port 0	Port 1	Port 2	Port 3	Port 4	Port 5
Integer	ALU, Shift	ALU, Fast LEA, Slow LEA, MUL	Load_Addr, Store_addr	Load_Addr Store_addr	Store_data	ALU, Shift, Branch, Fast LEA
SSE-Int, AVX-Int, MMX	Mul, Shift, STTNI, Int-Div, 128b-Mov	ALU, Shuf, Blend, 128b- Mov			Store_data	ALU, Shuf, Shift, Blend, 128b-Mov
SSE-FP, AVX-FP_low	Mul, Div, Blend, 256b-Mov	Add, CVT			Store_data	Shuf, Blend, 256b-Mov
X87, AVX-FP_High	Mul, Div, Blend, 256b-Mov	Add, CVT			Store_data	Shuf, Blend, 256b-Mov

After execution, the data is written back on a writeback bus corresponding to the dispatch port and the data type of the result. Micro-ops that are dispatched on the same port but have different latencies may need the write back bus at the same cycle. In these cases the execution of one of the micro-ops is delayed until the writeback bus is available. For example, MULPS (five cycles) and BLENDPS (one cycle) may collide if both are ready for execution on port 0: first the MULPS and four cycles later the BLENDPS. Sandy Bridge microarchitecture eliminates such collisions as long as the micro-ops write the results to different stacks. For example, integer ADD (one cycle) can be dispatched four cycles after MULPS (five cycles) since the integer ADD uses the integer stack while the MULPS uses the FP stack.

When a source of a micro-op executed in one stack comes from a micro-op executed in another stack, a one- or two-cycle delay can occur. The delay occurs also for transitions between Intel SSE integer and Intel SSE floating-point operations. In some of the cases the data transition is done using a micro-op that is added to the instruction flow. The following table describes how data, written back after execution, can bypass to micro-op execution in the following cycles.

Table E-11. Execution Core Writeback Latency (cycles)

	Integer	SSE-Int, AVX-Int, MMX	SSE-FP, AVX-FP_low	X87, AVX-FP_High
Integer	0	micro-op (port 0)	micro-op (port 0)	micro-op (port 0) + 1 cycle
SSE-Int, AVX-Int, MMX	micro-op (port 5) or micro-op (port 5) +1 cycle	0	1 cycle delay	0
SSE-FP, AVX-FP_low	micro-op (port 5) or micro-op (port 5) +1 cycle	1 cycle delay	0	micro-op (port 5) +1 cycle
X87, AVX-FP_High	micro-op (port 5) +1 cycle	0	micro-op (port 5) +1 cycle	0
Load	0	1 cycle delay	1 cycle delay	2 cycle delay

E.2.5 Cache Hierarchy

The cache hierarchy contains a first level instruction cache, a first level data cache (L1 DCache) and a second level (L2) cache, in each core. The L1D cache may be shared by two logical processors if the processor support Intel HyperThreading Technology. The L2 cache is shared by instructions and data. All cores in a physical processor package connect to a shared last level cache (LLC) via a ring connection.

The caches use the services of the Instruction Translation Lookaside Buffer (ITLB), Data Translation Lookaside Buffer (DTLB) and Shared Translation Lookaside Buffer (STLB) to translate linear addresses to physical address. Data coherency in all cache levels is maintained using the MESI protocol. For more information, see the Intel® 64 IA-32 Architectures Software Developer's Manual, Volume 3. Cache hierarchy details can be obtained at run-time using the CPUID instruction. see the *Intel® 64 and IA-32 Architectures Software Developer's Manual, Volume 2A*.

Table E-12. Cache Parameters

Level	Capacity	Associativity (ways)	Line Size (bytes)	Write Update Policy	Inclusive
L1 Data	32 KB	8	64	Writeback	-
Instruction	32 KB	8	N/A	N/A	-
L2 (Unified)	256 KB	8	64	Writeback	No
Third Level (LLC)	Varies, query CPUID leaf 4	Varies with cache size	64	Writeback	Yes

E.2.5.1 Load and Store Operation Overview

This section provides an overview of the load and store operations.

Loads

When an instruction reads data from a memory location that has write-back (WB) type, the processor looks for it in the caches and memory. Table E-13 shows the access lookup order and best case latency. The actual latency can vary depending on the cache queue occupancy, LLC ring occupancy, memory components, and their parameters.

Table E-13. Lookup Order and Load Latency

Level	Latency (cycles)	Bandwidth (per core per cycle)
L1 Data	4 ¹	2 x 16 bytes
L2 (Unified)	12	1 x 32 bytes
Third Level (LLC)	26-31 ²	1 x 32 bytes
L2 and L1 DCache in other cores if applicable	43- clean hit; 60 - dirty hit	

NOTES:

1. Subject to execution core bypass restriction shown in Table E-11.
2. Latency of L3 varies with product segment and sku. The values apply to second generation Intel Core processor families.

The LLC is inclusive of all cache levels above it - data contained in the core caches must also reside in the LLC. Each cache line in the LLC holds an indication of the cores that may have this line in their L2 and L1 caches. If there is an indication in the LLC that other cores may hold the line of interest and its state might have to modify, there is a lookup into the L1 DCache and L2 of these cores too. The lookup is called "clean" if it does not require fetching data from the other core caches. The lookup is called "dirty" if modified data has to be fetched from the other core caches and transferred to the loading core.

The latencies shown above are the best-case scenarios. Sometimes a modified cache line has to be evicted to make space for a new cache line. The modified cache line is evicted in parallel to bringing the new data and does not require additional latency. However, when data is written back to memory, the eviction uses cache bandwidth and possibly memory bandwidth as well. Therefore, when multiple cache misses require the eviction of modified lines within a short time, there is an overall degradation in cache response time. Memory access latencies vary based on occupancy of the memory controller queues, DRAM configuration, DDR parameters, and DDR paging behavior (if the requested page is a page-hit, page-miss or page-empty).

Stores

When an instruction writes data to a memory location that has a write back memory type, the processor first ensures that it has the line containing this memory location in its L1 DCache, in Exclusive or Modified MESI state. If the cache line is not there, in the right state, the processor fetches it from the next levels

of the memory hierarchy using a Read for Ownership request. The processor looks for the cache line in the following locations, in the specified order:

1. L1 DCache
2. L2
3. Last Level Cache
4. L2 and L1 DCache in other cores, if applicable
5. Memory

Once the cache line is in the L1 DCache, the new data is written to it, and the line is marked as Modified.

Reading for ownership and storing the data happens after instruction retirement and follows the order of store instruction retirement. Therefore, the store latency usually does not affect the store instruction itself. However, several sequential stores that miss the L1 DCache may have cumulative latency that can affect performance. As long as the store does not complete, its entry remains occupied in the store buffer. When the store buffer becomes full, new micro-ops cannot enter the execution pipe and execution might stall.

E.2.5.2 L1 DCache

The L1 DCache is the first level data cache. It manages all load and store requests from all types through its internal data structures. The L1 DCache:

- Enables loads and stores to issue speculatively and out of order.
- Ensures that retired loads and stores have the correct data upon retirement.
- Ensures that loads and stores follow the memory ordering rules of the IA-32 and Intel 64 instruction set architecture.

Table E-14. L1 Data Cache Components

Component	Sandy Bridge Microarchitecture	Nehalem Microarchitecture
Data Cache Unit (DCU)	32KB, 8 ways	32KB, 8 ways
Load buffers	64 entries	48 entries
Store buffers	36 entries	32 entries
Line fill buffers (LFB)	10 entries	10 entries

The DCU is organized as 32 KBytes, eight-way set associative. Cache line size is 64-bytes arranged in eight banks.

Internally, accesses are up to 16 bytes, with 256-bit Intel AVX instructions utilizing two 16-byte accesses. Two load operations and one store operation can be handled each cycle.

The L1 DCache maintains requests which cannot be serviced immediately to completion. Some reasons for requests that are delayed: cache misses, unaligned access that splits across cache lines, data not ready to be forwarded from a preceding store, loads experiencing bank collisions, and load block due to cache line replacement.

The L1 DCache can maintain up to 64 load micro-ops from allocation until retirement. It can maintain up to 36 store operations from allocation until the store value is committed to the cache, or written to the line fill buffers (LFB) in the case of non-temporal stores.

The L1 DCache can handle multiple outstanding cache misses and continue to service incoming stores and loads. Up to 10 requests of missing cache lines can be managed simultaneously using the LFB.

The L1 DCache is a write-back write-allocate cache. Stores that hit in the DCU do not update the lower levels of the memory hierarchy. Stores that miss the DCU allocate a cache line.

Loads

The L1 DCache architecture can service two loads per cycle, each of which can be up to 16 bytes. Up to 32 loads can be maintained at different stages of progress, from their allocation in the out of order engine until the loaded value is returned to the execution core.

Loads can:

- Read data before preceding stores when the load address and store address ranges are known not to conflict.
- Be carried out speculatively, before preceding branches are resolved.
- Take cache misses out of order and in an overlapped manner.

Loads cannot:

- Speculatively take any sort of fault or trap.
- Speculatively access uncacheable memory.

The common load latency is five cycles. When using a simple addressing mode, base plus offset that is smaller than 2048, the load latency can be four cycles. This technique is especially useful for pointer-chasing code. However, overall latency varies depending on the target register data type due to stack bypass. See Section E.2.4 for more information.

The following table lists overall load latencies. These latencies assume the common case of flat segment, that is, segment base address is zero. If segment base is not zero, load latency increases.

Table E-15. Effect of Addressing Modes on Load Latency

Data Type/Addressing Mode	Base + Offset > 2048; Base + Index [+ Offset]	Base + Offset < 2048
Integer	5	4
MMX, SSE, 128-bit AVX	6	5
X87	7	6
256-bit AVX	7	7

Stores

Stores to memory are executed in two phases:

- Execution phase. Fills the store buffers with linear and physical address and data. Once store address and data are known, the store data can be forwarded to the following load operations that need it.
- Completion phase. After the store retires, the L1 DCache moves its data from the store buffers to the DCU, up to 16 bytes per cycle.

Address Translation

The DTLB can perform three linear to physical address translations every cycle, two for load addresses and one for a store address. If the address is missing in the DTLB, the processor looks for it in the STLB, which holds data and instruction address translations. The penalty of a DTLB miss that hits the STLB is seven cycles. Large page support include 1G byte pages, in addition to 4K and 2M/4M pages.

The DTLB and STLB are four way set associative. The following table specifies the number of entries in the DTLB and STLB.

Table E-16. DTLB and STLB Parameters

TLB	Page Size	Entries
DTLB	4KB	64
	2MB/4MB	32
	1GB	4
STLB	4KB	512

Store Forwarding

If a load follows a store and reloads the data that the store writes to memory, the data can forward directly from the store operation to the load. This process, called store to load forwarding, saves cycles by enabling the load to obtain the data directly from the store operation instead of through memory. You can take advantage of store forwarding to quickly move complex structures without losing the ability to forward the subfields. The memory control unit can handle store forwarding situations with less restrictions compared to previous micro-architectures.

The following rules must be met to enable store to load forwarding:

- The store must be the last store to that address, prior to the load.
- The store must contain all data being loaded.
- The load is from a write-back memory type and neither the load nor the store are non-temporal accesses.

Stores cannot forward to loads in the following cases:

- Four byte and eight byte loads that cross eight byte boundary, relative to the preceding 16- or 32-byte store.
- Any load that crosses a 16-byte boundary of a 32-byte store.

Table E-17 to Table E-20 detail the store to load forwarding behavior. For a given store size, all the loads that may overlap are shown and specified by 'F'. Forwarding from 32 byte store is similar to forwarding from each of the 16 byte halves of the store. Cases that cannot forward are shown as 'N'.

Table E-17. Store Forwarding Conditions (1 and 2 byte stores)

Store Size	Load Size	Load Alignment															
		0	1	2	3	4	5	6	7	8	9	10	11	12	13	14	15
1	1	F															
2	1	F	F														
	2	F	N														

Table E-18. Store Forwarding Conditions (4-16 byte stores)

Store Size	Load Size	Load Alignment															
		0	1	2	3	4	5	6	7	8	9	10	11	12	13	14	15
4	1	F	F	F	F												
	2	F	F	F	N												
	4	F	N	N	N												
8	1	F	F	F	F	F	F	F	F								
	2	F	F	F	F	F	F	F	N								
	4	F	F	F	F	F	N	N	N								
	8	F	N	N	N	N	N	N	N								
16	1	F	F	F	F	F	F	F	F	F	F	F	F	F	F	F	F
	2	F	F	F	F	F	F	F	F	F	F	F	F	F	F	F	N
	4	F	F	F	F	F	N	N	N	F	F	F	F	F	N	N	N
	8	F	N	N	N	N	N	N	N	F	N	N	N	N	N	N	N
	16	F	N	N	N	N	N	N	N	N	N	N	N	N	N	N	N

Table E-19. 32-byte Store Forwarding Conditions (0-15 byte alignment)

Store Size	Load Size	Load Alignment															
		0	1	2	3	4	5	6	7	8	9	10	11	12	13	14	15
32	1	F	F	F	F	F	F	F	F	F	F	F	F	F	F	F	F
	2	F	F	F	F	F	F	F	F	F	F	F	F	F	F	F	N
	4	F	F	F	F	F	N	N	N	F	F	F	F	F	N	N	N
	8	F	N	N	N	N	N	N	N	F	N	N	N	N	N	N	N
	16	F	N	N	N	N	N	N	N	N	N	N	N	N	N	N	N
	32	F	N	N	N	N	N	N	N	N	N	N	N	N	N	N	N

Table E-20. 32-byte Store Forwarding Conditions (16-31 byte alignment)

Store Size	Load Size	Load Alignment															
		16	17	18	19	20	21	22	23	24	25	26	27	28	29	30	31
32	1	F	F	F	F	F	F	F	F	F	F	F	F	F	F	F	F
	2	F	F	F	F	F	F	F	F	F	F	F	F	F	F	F	N
	4	F	F	F	F	F	N	N	N	F	F	F	F	F	N	N	N
	8	F	N	N	N	N	N	N	N	F	N	N	N	N	N	N	N
	16	F	N	N	N	N	N	N	N	N	N	N	N	N	N	N	N
	32	N	N	N	N	N	N	N	N	N	N	N	N	N	N	N	N

Memory Disambiguation

A load operation may depend on a preceding store. Many microarchitectures block loads until all preceding store addresses are known. The memory disambiguator predicts which loads will not depend on any previous stores whose addresses aren't yet known. When the disambiguator predicts that a load does not have such a dependency, the load takes its data from an earlier store to the same address. This hides the load latency. Eventually, the prediction is verified. If the load did indeed depend on a store whose address was unknown at the time the load executed, this conflict is detected and the load and all succeeding instructions are re-executed.

The following loads are not disambiguated. The execution of these loads is stalled until addresses of all previous stores are known.

- Loads that cross the 16-byte aligned boundary, other than 32-byte loads.
- 32-byte Intel AVX loads that are not 32-byte aligned.

Bank Conflict

Since 16-byte loads can cover up to three banks, and two loads can happen every cycle, it is possible that six of the eight banks may be accessed per cycle, for loads. A bank conflict happens when two load accesses need the same bank (their address has the same 2-4 bit value) in different sets, at the same time. When a bank conflict occurs, one of the load accesses is recycled internally.

In many cases two loads access exactly the same bank in the same cache line, as may happen when popping operands off the stack, or any sequential accesses. In these cases, conflict does not occur and the loads are serviced simultaneously.

E.2.5.3 Ring Interconnect and Last Level Cache

The system-on-a-chip design provides a high bandwidth bi-directional ring bus to connect between the IA cores and various sub-systems in the uncore. In the second generation Intel Core processor 2xxx series, the uncore subsystem include a system agent, the graphics unit (GT) and the last level cache (LLC).

The LLC consists of multiple cache slices. The number of slices is equal to the number of IA cores. Each slice has logic portion and data array portion. The logic portion handles data coherency, memory ordering, access to the data array portion, LLC misses and writeback to memory, and more. The data array portion stores cache lines. Each slice contains a full cache port that can supply 32 bytes/cycle.

The physical addresses of data kept in the LLC data arrays are distributed among the cache slices by a hash function, such that addresses are uniformly distributed. The data array in a cache block may have 4/8/12/16 ways corresponding to 0.5M/1M/1.5M/2M block size. However, due to the address distribution among the cache blocks from the software point of view, this does not appear as a normal N-way cache.

From the processor cores and the GT view, the LLC act as one shared cache with multiple ports and bandwidth that scales with the number of cores. The LLC hit latency, ranging between 26-31 cycles, depends on the core location relative to the LLC block, and how far the request needs to travel on the ring.

The number of cache-slices increases with the number of cores, therefore the ring and LLC are not likely to be a bandwidth limiter to core operation.

The GT sits on the same ring interconnect, and uses the LLC for its data operations as well. In this respect it is very similar to an IA core. Therefore, high bandwidth graphic applications using cache bandwidth and significant cache footprint, can interfere, to some extent, with core operations.

All the traffic that cannot be satisfied by the LLC, such as LLC misses, dirty line writeback, non-cacheable operations, and MMIO/IO operations, still travels through the cache-slice logic portion and the ring, to the system agent.

In the Intel Xeon Processor E5 Family, the uncore subsystem does not include the graphics unit (GT). Instead, the uncore subsystem contains many more components, including an LLC with larger capacity and snooping capabilities to support multiple processors, Intel® QuickPath Interconnect interfaces that can support multi-socket platforms, power management control hardware, and a system agent capable of supporting high-bandwidth traffic from memory and I/O devices.

In the Intel Xeon processor E5 2xxx or 4xxx families, the LLC capacity generally scales with the number of processor cores with 2.5 MBytes per core.

E.2.5.4 Data Prefetching

Data can be speculatively loaded to the L1 DCache using software prefetching, hardware prefetching, or any combination of the two.

You can use the four Streaming SIMD Extensions (SSE) prefetch instructions to enable software-controlled prefetching. These instructions are hints to bring a cache line of data into the desired levels of the cache hierarchy. The software-controlled prefetch is intended for prefetching data, but not for prefetching code.

The rest of this section describes the various hardware prefetching mechanisms provided by Sandy Bridge microarchitecture and their improvement over previous processors. The goal of the prefetchers is to automatically predict which data the program is about to consume. If this data is not close-by to the execution core or inner cache, the prefetchers bring it from the next levels of cache hierarchy and memory. Prefetching has the following effects:

- Improves performance if data is arranged sequentially in the order used in the program.
- May cause slight performance degradation due to bandwidth issues, if access patterns are sparse instead of local.
- On rare occasions, if the algorithm's working set is tuned to occupy most of the cache and unneeded prefetches evict lines required by the program, hardware prefetcher may cause severe performance degradation due to cache capacity of L1.

Data Prefetch to L1 Data Cache

Data prefetching is triggered by load operations when the following conditions are met:

- Load is from writeback memory type.
- The prefetched data is within the same 4K byte page as the load instruction that triggered it.
- No fence is in progress in the pipeline.
- Not many other load misses are in progress.
- There is not a continuous stream of stores.

Two hardware prefetchers load data to the L1 DCache:

- **Data cache unit (DCU) prefetcher.** This prefetcher, also known as the streaming prefetcher, is triggered by an ascending access to very recently loaded data. The processor assumes that this access is part of a streaming algorithm and automatically fetches the next line.
- **Instruction pointer (IP)-based stride prefetcher.** This prefetcher keeps track of individual load instructions. If a load instruction is detected to have a regular stride, then a prefetch is sent to the next address which is the sum of the current address and the stride. This prefetcher can prefetch forward or backward and can detect strides of up to 2K bytes.

Data Prefetch to the L2 and Last Level Cache

The following two hardware prefetchers fetched data from memory to the L2 cache and last level cache:

Spatial Prefetcher: This prefetcher strives to complete every cache line fetched to the L2 cache with the pair line that completes it to a 128-byte aligned chunk.

Streamer: This prefetcher monitors read requests from the L1 cache for ascending and descending sequences of addresses. Monitored read requests include L1 DCache requests initiated by load and store operations and by the hardware prefetchers, and L1 ICache requests for code fetch. When a forward or backward stream of requests is detected, the anticipated cache lines are prefetched. Prefetched cache lines must be in the same 4K page.

The streamer and spatial prefetcher prefetch the data to the last level cache. Typically data is brought also to the L2 unless the L2 cache is heavily loaded with missing demand requests.

Enhancement to the streamer includes the following features:

- The streamer may issue two prefetch requests on every L2 lookup. The streamer can run up to 20 lines ahead of the load request.
- Adjusts dynamically to the number of outstanding requests per core. If there are not many outstanding requests, the streamer prefetches further ahead. If there are many outstanding requests it prefetches to the LLC only and less far ahead.
- When cache lines are far ahead, it prefetches to the last level cache only and not to the L2. This method avoids replacement of useful cache lines in the L2 cache.
- Detects and maintains up to 32 streams of data accesses. For each 4K byte page, you can maintain one forward and one backward stream can be maintained.

E.2.6 System Agent

The system agent implemented in the second generation Intel Core processor family contains the following components:

- An arbiter that handles all accesses from the ring domain and from I/O (PCIe* and DMI) and routes the accesses to the right place.
- PCIe controllers connect to external PCIe devices. The PCIe controllers have different configuration possibilities that varies with product segment specifics: x16+x4, x8+x8+x4, x8+x4+x4+x4.
- DMI controller connects to the PCH chipset.
- Integrated display engine, Flexible Display Interconnect, and Display Port, for the internal graphic operations.
- Memory controller.

All main memory traffic is routed from the arbiter to the memory controller. The memory controller in the second generation Intel Core processor 2xxx series support two channels of DDR, with data rates of 1066MHz, 1333MHz and 1600MHz, and 8 bytes per cycle, depending on the unit type, system configuration and DRAMs. Addresses are distributed between memory channels based on a local hash function that attempts to balance the load between the channels in order to achieve maximum bandwidth and minimum hotspot collisions.

For best performance, populate both channels with equal amounts of memory, preferably the exact same types of DIMMs. In addition, using more ranks for the same amount of memory, results in somewhat better memory bandwidth, since more DRAM pages can be open simultaneously. For best performance, populate the system with the highest supported speed DRAM (1333MHz or 1600MHz data rates, depending on the max supported frequency) with the best DRAM timings.

The two channels have separate resources and handle memory requests independently. The memory controller contains a high-performance out-of-order scheduler that attempts to maximize memory bandwidth while minimizing latency. Each memory channel contains a 32 cache-line write-data-buffer. Writes to the memory controller are considered completed when they are written to the write-data-buffer. The write-data-buffer is flushed out to main memory at a later time, not impacting write latency.

Partial writes are not handled efficiently on the memory controller and may result in read-modify-write operations on the DDR channel if the partial-writes do not complete a full cache-line in time. Software should avoid creating partial write transactions whenever possible and consider alternative, such as buffering the partial writes into full cache line writes.

The memory controller also supports high-priority isochronous requests (such as USB isochronous, and Display isochronous requests). High bandwidth of memory requests from the integrated display engine takes up some of the memory bandwidth and impacts core access latency to some degree.

E.2.7 Ivy Bridge Microarchitecture

3rd generation Intel Core processors are based on Ivy Bridge microarchitecture. Most of the features described in Section E.2.1 - Section E.2.6 also apply to Ivy Bridge microarchitecture. This section covers feature differences in microarchitecture that can affect coding and performance.

Support for new instructions enabling include:

- Numeric conversion to and from half-precision floating-point values.
- Hardware-based random number generator compliant to NIST SP 800-90A.
- Reading and writing to FS/GS base registers in any ring to improve user-mode threading support.

For details about using the hardware based random number generator instruction RDRAND, please refer to the article available from Intel Software Network at <https://software.intel.com/en-us/articles/intel-digital-random-number-generator-drng-software-implementation-guide/>.

A small number of microarchitectural enhancements that can be beneficial to software:

- **Hardware prefetch enhancement:** A next-page prefetcher (NPP) is added in Ivy Bridge microarchitecture. The NPP is triggered by sequential accesses to cache lines approaching the page boundary, either upwards or downwards.
- **Zero-latency register move operation:** A subset of register-to-register MOV instructions are executed at the front end, conserving scheduling and execution resource in the out-of-order engine.
- **Front end enhancement:** In Sandy Bridge microarchitecture, the micro-op queue is statically partitioned to provide 28 entries for each logical processor, irrespective of software executing in single thread or multiple threads. If one logical processor is not active in Ivy Bridge microarchitecture, then a single thread executing on that processor core can use the 56 entries in the micro-op queue. In this case, the LSD can handle larger loop structure that would require more than 28 entries.
- The latency and throughput of some instructions have been improved over those of Sandy Bridge microarchitecture. For example, 256-bit packed floating-point divide and square root operations are faster; ROL and ROR instructions are also improved.

E.3 INTEL® CORE™ MICROARCHITECTURE AND ENHANCED INTEL® CORE™ MICROARCHITECTURE

Intel Core microarchitecture introduces the following features that enable high performance and power-efficient performance for single-threaded as well as multi-threaded workloads:

- **Intel® Wide Dynamic Execution** enables each processor core to fetch, dispatch, execute with high bandwidths and retire up to four instructions per cycle. Features include:
 - Fourteen-stage efficient pipeline.
 - Three arithmetic logical units.
 - Four decoders to decode up to five instruction per cycle.
 - Macro-fusion and micro-fusion to improve front end throughput.
 - Peak issue rate of dispatching up to six micro-ops per cycle.
 - Peak retirement bandwidth of up to four micro-ops per cycle.
 - Advanced branch prediction.
 - Stack pointer tracker to improve efficiency of executing function/procedure entries and exits.
- **Intel® Advanced Smart Cache** delivers higher bandwidth from the second level cache to the core, optimal performance and flexibility for single-threaded and multi-threaded applications. Features include:
 - Optimized for multicore and single-threaded execution environments.
 - 256 bit internal data path to improve bandwidth from L2 to first-level data cache.

- Unified, shared second-level cache of 4 Mbyte, 16 way (or 2 MByte, 8 way).
- **Intel® Smart Memory Access** prefetches data from memory in response to data access patterns and reduces cache-miss exposure of out-of-order execution. Features include:
 - Hardware prefetchers to reduce effective latency of second-level cache misses.
 - Hardware prefetchers to reduce effective latency of first-level data cache misses.
 - Memory disambiguation to improve efficiency of speculative execution engine.
- **Intel® Advanced Digital Media Boost** improves most 128-bit SIMD instructions with single-cycle throughput and floating-point operations. Features include:
 - Single-cycle throughput of most 128-bit SIMD instructions (except 128-bit shuffle, pack, unpack operations)
 - Up to eight floating-point operations per cycle
 - Three issue ports available to dispatching SIMD instructions for execution.

The Enhanced Intel Core microarchitecture supports all of the features of Intel Core microarchitecture and provides a comprehensive set of enhancements.

- **Intel® Wide Dynamic Execution** includes several enhancements:
 - A radix-16 divider replacing previous radix-4 based divider to speedup long-latency operations such as divisions and square roots.
 - Improved system primitives to speedup long-latency operations such as RDTSC, STI, CLI, and VM exit transitions.
- **Intel® Advanced Smart Cache** provides up to 6 MBytes of second-level cache shared between two processor cores (quad-core processors have up to 12 MBytes of L2); up to 24 way/set associativity.
- **Intel® Smart Memory Access** supports high-speed system bus up 1600 MHz and provides more efficient handling of memory operations such as split cache line load and store-to-load forwarding situations.
- **Intel® Advanced Digital Media Boost** provides 128-bit shuffler unit to speedup shuffle, pack, unpack operations; adds support for 47 SSE4.1 instructions.

In the sub-sections of 2.1.x, most of the descriptions on Intel Core microarchitecture also applies to Enhanced Intel Core microarchitecture. Differences between them are note explicitly.

E.3.1 Intel® Core™ Microarchitecture Pipeline Overview

The pipeline of the Intel Core microarchitecture contains:

- An in-order issue front end that fetches instruction streams from memory, with four instruction decoders to supply decoded instruction (micro-ops) to the out-of-order execution core.
- An out-of-order superscalar execution core that can issue up to six micro-ops per cycle (see Table E-22) and reorder micro-ops to execute as soon as sources are ready and execution resources are available.
- An in-order retirement unit that ensures the results of execution of micro-ops are processed and architectural states are updated according to the original program order.

Intel Core 2 Extreme processor X6800, Intel Core 2 Duo processors and Intel Xeon processor 3000, 5100 series implement two processor cores based on the Intel Core microarchitecture. Intel Core 2 Extreme quad-core processor, Intel Core 2 Quad processors and Intel Xeon processor 3200 series, 5300 series implement four processor cores. Each physical package of these quad-core processors contains two processor dies, each die containing two processor cores. The functionality of the subsystems in each core are depicted in Figure E-5.

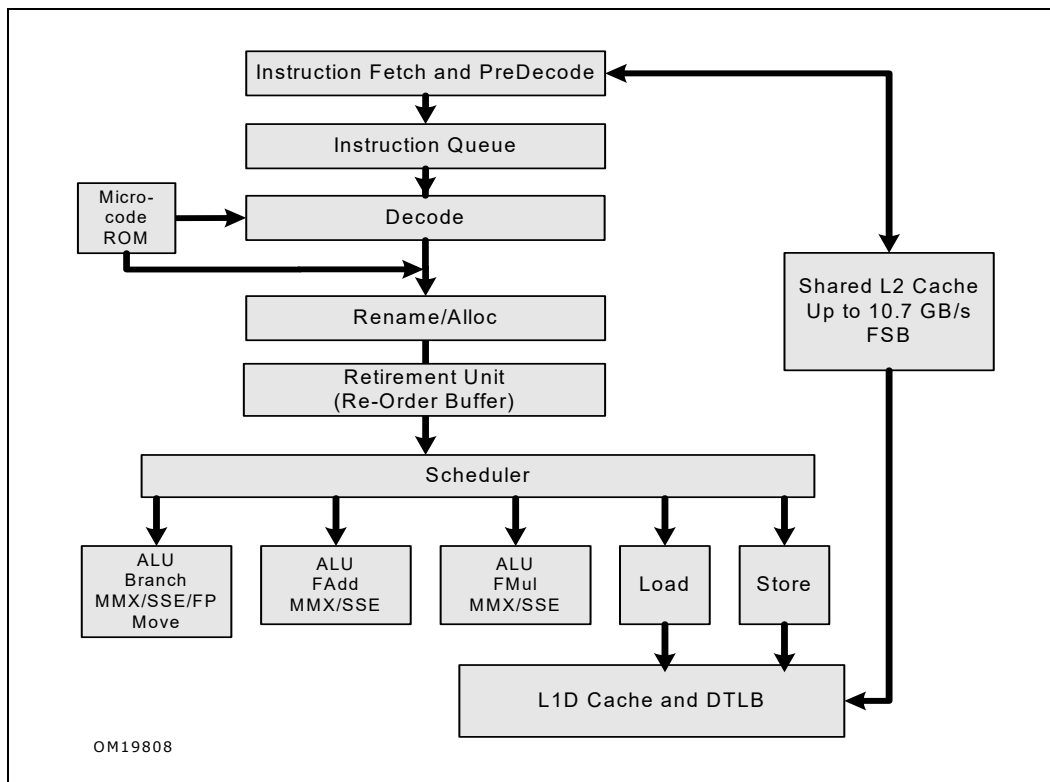

Figure E-5. Intel Core Microarchitecture Pipeline Functionality

E.3.2 Front End

The front ends needs to supply decoded instructions (micro-ops) and sustain the stream to a six-issue wide out-of-order engine. The components of the front end, their functions, and the performance challenges to microarchitectural design are described in Table E-21.

Table E-21. Components of the Front End

Component	Functions	Performance Challenges
Branch Prediction Unit (BPU)	<ul style="list-style-type: none"> Helps the instruction fetch unit fetch the most likely instruction to be executed by predicting the various branch types: conditional, indirect, direct, call, and return. Uses dedicated hardware for each type. 	<ul style="list-style-type: none"> Enables speculative execution. Improves speculative execution efficiency by reducing the amount of code in the “non-architected path”¹ to be fetched into the pipeline.
Instruction Fetch Unit	<ul style="list-style-type: none"> Prefetches instructions that are likely to be executed Caches frequently-used instructions Predecodes and buffers instructions, maintaining a constant bandwidth despite irregularities in the instruction stream 	<ul style="list-style-type: none"> Variable length instruction format causes unevenness (bubbles) in decode bandwidth. Taken branches and misaligned targets causes disruptions in the overall bandwidth delivered by the fetch unit.

Table E-21. Components of the Front End (Contd.)

Component	Functions	Performance Challenges
Instruction Queue and Decode Unit	<ul style="list-style-type: none"> Decodes up to four instructions, or up to five with macro-fusion Stack pointer tracker algorithm for efficient procedure entry and exit Implements the Macro-Fusion feature, providing higher performance and efficiency The Instruction Queue is also used as a loop cache, enabling some loops to be executed with both higher bandwidth and lower power 	<ul style="list-style-type: none"> Varying amounts of work per instruction requires expansion into variable numbers of micro-ops. Prefix adds a dimension of decoding complexity. Length Changing Prefix (LCP) can cause front end bubbles.

NOTES:

- Code paths that the processor thought it should execute but then found out it should go in another path and therefore reverted from its initial intention.

E.3.2.1 Branch Prediction Unit

Branch prediction enables the processor to begin executing instructions long before the branch outcome is decided. All branches utilize the BPU for prediction. The BPU contains the following features:

- 16-entry Return Stack Buffer (RSB). It enables the BPU to accurately predict RET instructions.
- Front end queuing of BPU lookups. The BPU makes branch predictions for 32 bytes at a time, twice the width of the fetch engine. This enables taken branches to be predicted with no penalty.

Even though this BPU mechanism generally eliminates the penalty for taken branches, software should still regard taken branches as consuming more resources than do not-taken branches.

The BPU makes the following types of predictions:

- Direct Calls and Jumps. Targets are read as a target array, without regarding the taken or not-taken prediction.
- Indirect Calls and Jumps. These may either be predicted as having a monotonic target or as having targets that vary in accordance with recent program behavior.
- Conditional branches. Predicts the branch target and whether or not the branch will be taken.

For information about optimizing software for the BPU, see Section 3.4, “Optimizing the Front End.”

E.3.2.2 Instruction Fetch Unit

The instruction fetch unit comprises the instruction translation lookaside buffer (ITLB), an instruction prefetcher, the instruction cache and the predecode logic of the instruction queue (IQ).

Instruction Cache and ITLB

An instruction fetch is a 16-byte aligned lookup through the ITLB into the instruction cache and instruction prefetch buffers. A hit in the instruction cache causes 16 bytes to be delivered to the instruction predecoder. Typical programs average slightly less than 4 bytes per instruction, depending on the code being executed. Since most instructions can be decoded by all decoders, an entire fetch can often be consumed by the decoders in one cycle.

A misaligned target reduces the number of instruction bytes by the amount of offset into the 16 byte fetch quantity. A taken branch reduces the number of instruction bytes delivered to the decoders since the bytes after the taken branch are not decoded. Branches are taken approximately every 10 instructions in typical integer code, which translates into a “partial” instruction fetch every 3 or 4 cycles.

Due to stalls in the rest of the machine, front end starvation does not usually cause performance degradation. For extremely fast code with larger instructions (such as SSE2 integer media kernels), it may be beneficial to use targeted alignment to prevent instruction starvation.

Instruction PreDecode

The predecode unit accepts the sixteen bytes from the instruction cache or prefetch buffers and carries out the following tasks:

- Determine the length of the instructions.
- Decode all prefixes associated with instructions.
- Mark various properties of instructions for the decoders (for example, “is branch.”).

The predecode unit can write up to six instructions per cycle into the instruction queue. If a fetch contains more than six instructions, the predecoder continues to decode up to six instructions per cycle until all instructions in the fetch are written to the instruction queue. Subsequent fetches can only enter predecoding after the current fetch completes.

For a fetch of seven instructions, the predecoder decodes the first six in one cycle, and then only one in the next cycle. This process would support decoding 3.5 instructions per cycle. Even if the instruction per cycle (IPC) rate is not fully optimized, it is higher than the performance seen in most applications. In general, software usually does not have to take any extra measures to prevent instruction starvation.

The following instruction prefixes cause problems during length decoding. These prefixes can dynamically change the length of instructions and are known as length changing prefixes (LCPs):

- Operand Size Override (66H) preceding an instruction with a word immediate data.
- Address Size Override (67H) preceding an instruction with a mod R/M in real, 16-bit protected or 32-bit protected modes.

When the predecoder encounters an LCP in the fetch line, it must use a slower length decoding algorithm. With the slower length decoding algorithm, the predecoder decodes the fetch in 6 cycles, instead of the usual 1 cycle.

Normal queuing within the processor pipeline usually cannot hide LCP penalties.

The REX prefix (4xh) in the Intel 64 architecture instruction set can change the size of two classes of instruction: MOV offset and MOV immediate. Nevertheless, it does not cause an LCP penalty and hence is not considered an LCP.

E.3.2.3 Instruction Queue (IQ)

The instruction queue is 18 instructions deep. It sits between the instruction predecode unit and the instruction decoders. It sends up to five instructions per cycle, and supports one macro-fusion per cycle. It also serves as a loop cache for loops smaller than 18 instructions. The loop cache operates as described below.

A Loop Stream Detector (LSD) resides in the BPU. The LSD attempts to detect loops which are candidates for streaming from the instruction queue (IQ). When such a loop is detected, the instruction bytes are locked down and the loop is allowed to stream from the IQ until a misprediction ends it. When the loop plays back from the IQ, it provides higher bandwidth at reduced power (since much of the rest of the front end pipeline is shut off).

The LSD provides the following benefits:

- No loss of bandwidth due to taken branches.
- No loss of bandwidth due to misaligned instructions.
- No LCP penalties, as the pre-decode stage has already been passed.
- Reduced front end power consumption, because the instruction cache, BPU and predecode unit can be idle.

Software should use the loop cache functionality opportunistically. Loop unrolling and other code optimizations may make the loop too big to fit into the LSD. For high performance code, loop unrolling is generally preferable for performance even when it overflows the loop cache capability.

E.3.2.4 Instruction Decode

The Intel Core microarchitecture contains four instruction decoders. The first, Decoder 0, can decode Intel 64 and IA-32 instructions up to 4 micro-ops in size. Three other decoders handle single micro-op instructions. The microsequencer can provide up to 3 micro-ops per cycle, and helps decode instructions larger than 4 micro-ops.

All decoders support the common cases of single micro-op flows, including: micro-fusion, stack pointer tracking and macro-fusion. Thus, the three simple decoders are not limited to decoding single micro-op instructions. Packing instructions into a 4-1-1-1 template is not necessary and not recommended.

Macro-fusion merges two instructions into a single micro-op. Intel Core microarchitecture is capable of one macro-fusion per cycle in 32-bit operation (including compatibility sub-mode of the Intel 64 architecture), but not in 64-bit mode because code that uses longer instructions (length in bytes) more often is less likely to take advantage of hardware support for macro-fusion.

E.3.2.5 Stack Pointer Tracker

The Intel 64 and IA-32 architectures have several commonly used instructions for parameter passing and procedure entry and exit: PUSH, POP, CALL, LEAVE and RET. These instructions implicitly update the stack pointer register (RSP), maintaining a combined control and parameter stack without software intervention. These instructions are typically implemented by several micro-ops in previous microarchitectures.

The Stack Pointer Tracker moves all these implicit RSP updates to logic contained in the decoders themselves. The feature provides the following benefits:

- Improves decode bandwidth, as PUSH, POP and RET are single micro-op instructions in Intel Core microarchitecture.
- Conserves execution bandwidth as the RSP updates do not compete for execution resources.
- Improves parallelism in the out of order execution engine as the implicit serial dependencies between micro-ops are removed.
- Improves power efficiency as the RSP updates are carried out on small, dedicated hardware.

E.3.2.6 Micro-fusion

Micro-fusion fuses multiple micro-ops from the same instruction into a single complex micro-op. The complex micro-op is dispatched in the out-of-order execution core. Micro-fusion provides the following performance advantages:

- Improves instruction bandwidth delivered from decode to retirement.
- Reduces power consumption as the complex micro-op represents more work in a smaller format (in terms of bit density), reducing overall “bit-toggling” in the machine for a given amount of work and virtually increasing the amount of storage in the out-of-order execution engine.

Many instructions provide register flavors and memory flavors. The flavor involving a memory operand will decode into a longer flow of micro-ops than the register version. Micro-fusion enables software to use memory to register operations to express the actual program behavior without worrying about a loss of decode bandwidth.

E.3.3 Execution Core

The execution core of the Intel Core microarchitecture is superscalar and can process instructions out of order. When a dependency chain causes the machine to wait for a resource (such as a second-level data

cache line), the execution core executes other instructions. This increases the overall rate of instructions executed per cycle (IPC).

The execution core contains the following three major components:

- **Renamer** — Moves micro-ops from the front end to the execution core. Architectural registers are renamed to a larger set of microarchitectural registers. Renaming eliminates false dependencies known as read-after-read and write-after-read hazards.
- **Reorder buffer (ROB)** — Holds micro-ops in various stages of completion, buffers completed micro-ops, updates the architectural state in order, and manages ordering of exceptions. The ROB has 96 entries to handle instructions in flight.
- **Reservation station (RS)** — Queues micro-ops until all source operands are ready, schedules and dispatches ready micro-ops to the available execution units. The RS has 32 entries.

The initial stages of the out of order core move the micro-ops from the front end to the ROB and RS. In this process, the out of order core carries out the following steps:

- Allocates resources to micro-ops (for example: these resources could be load or store buffers).
- Binds the micro-op to an appropriate issue port.
- Renames sources and destinations of micro-ops, enabling out of order execution.
- Provides data to the micro-op when the data is either an immediate value or a register value that has already been calculated.

The following list describes various types of common operations and how the core executes them efficiently:

- **Micro-ops with single-cycle latency** — Most micro-ops with single-cycle latency can be executed by multiple execution units, enabling multiple streams of dependent operations to be executed quickly.
- **Frequently-used μ ops with longer latency** — These micro-ops have pipelined execution units so that multiple micro-ops of these types may be executing in different parts of the pipeline simultaneously.
- **Operations with data-dependent latencies** — Some operations, such as division, have data dependent latencies. Integer division parses the operands to perform the calculation only on significant portions of the operands, thereby speeding up common cases of dividing by small numbers.
- **Floating-point operations with fixed latency for operands that meet certain restrictions** — Operands that do not fit these restrictions are considered exceptional cases and are executed with higher latency and reduced throughput. The lower-throughput cases do not affect latency and throughput for more common cases.
- **Memory operands with variable latency, even in the case of an L1 cache hit** — Loads that are not known to be safe from forwarding may wait until a store-address is resolved before executing. The memory order buffer (MOB) accepts and processes all memory operations. See Section E.3.4 for more information about the MOB.

E.3.3.1 Issue Ports and Execution Units

The scheduler can dispatch up to six micro-ops per cycle through the issue ports. The issue ports of Intel Core microarchitecture and Enhanced Intel Core microarchitecture are depicted in Table E-22, the former is denoted by its CPUID signature of DisplayFamily_DisplayModel value of 06_0FH, the latter denoted by the corresponding signature value of 06_17H. The table provides latency and throughput data of common integer and floating-point (FP) operations for each issue port in cycles.

Table E-22. Issue Ports of Intel Core Microarchitecture and Enhanced Intel Core Microarchitecture

Executable operations	Latency, Throughput		Comment ¹
	Signature = 06_0FH	Signature = 06_17H	
Integer ALU	1, 1	1, 1	Includes 64-bit mode integer MUL; Issue port 0; Writeback port 0;
Integer SIMD ALU	1, 1	1, 1	
FP/SIMD/SSE2 Move and Logic	1, 1	1, 1	
Single-precision (SP) FP MUL	4, 1	4, 1	Issue port 0; Writeback port 0
Double-precision FP MUL	5, 1	5, 1	
FP MUL (X87)	5, 2	5, 2	Issue port 0; Writeback port 0 FP shuffle does not handle QW shuffle.
FP Shuffle	1, 1	1, 1	
DIV/SQRT			
Integer ALU	1, 1	1, 1	Excludes 64-bit mode integer MUL; Issue port 1; Writeback port 1;
Integer SIMD ALU	1, 1	1, 1	
FP/SIMD/SSE2 Move and Logic	1, 1	1, 1	
FP ADD	3, 1	3, 1	Issue port 1; Writeback port 1;
QW Shuffle	1, 1 ²	1, 1 ³	
Integer loads	3, 1	3, 1	Issue port 2; Writeback port 2;
FP loads	4, 1	4, 1	
Store address ⁴	3, 1	3, 1	Issue port 3;
Store data ⁵			Issue Port 4;
Integer ALU	1, 1	1, 1	Issue port 5; Writeback port 5;
Integer SIMD ALU	1, 1	1, 1	
FP/SIMD/SSE2 Move and Logic	1, 1	1, 1	
QW shuffles	1, 1 ²	1, 1 ³	Issue port 5; Writeback port 5;
128-bit Shuffle/Pack/Unpack	2-4, 2-4 ⁶	1-3, 1 ⁷	

NOTES:

- Mixing operations of different latencies that use the same port can result in writeback bus conflicts; this can reduce overall throughput.
- 128-bit instructions executes with longer latency and reduced throughput.
- Uses 128-bit shuffle unit in port 5.
- Prepares the store forwarding and store retirement logic with the address of the data being stored.
- Prepares the store forwarding and store retirement logic with the data being stored.
- Varies with instructions; 128-bit instructions are executed using QW shuffle units.
- Varies with instructions, 128-bit shuffle unit replaces QW shuffle units in Intel Core microarchitecture.

In each cycle, the RS can dispatch up to six micro-ops. Each cycle, up to 4 results may be written back to the RS and ROB, to be used as early as the next cycle by the RS. This high execution bandwidth enables execution bursts to keep up with the functional expansion of the micro-fused micro-ops that are decoded and retired.

The execution core contains the following three execution stacks:

- SIMD integer.
- Regular integer.
- x87/SIMD floating-point.

The execution core also contains connections to and from the memory cluster. See Figure E-6.

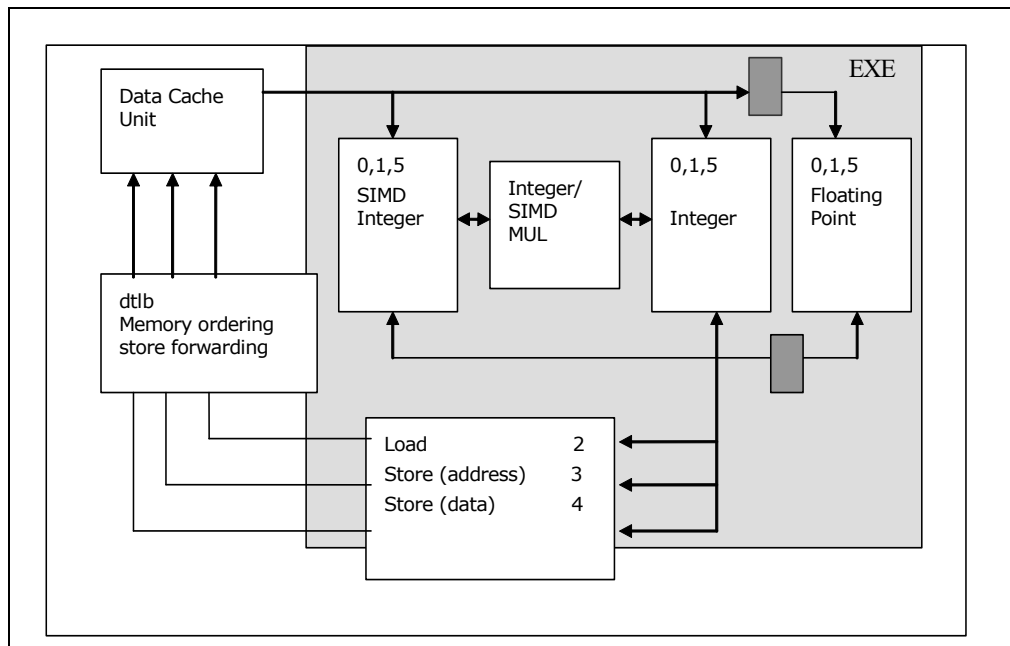

Figure E-6. Execution Core of Intel Core Microarchitecture

Notice that the two dark squares inside the execution block (in grey color) and appear in the path connecting the integer and SIMD integer stacks to the floating-point stack. This delay shows up as an extra cycle called a bypass delay. Data from the L1 cache has one extra cycle of latency to the floating-point unit. The dark-colored squares in Figure E-6 represent the extra cycle of latency.

E.3.4 Intel® Advanced Memory Access

The Intel Core microarchitecture contains an instruction cache and a first-level data cache in each core. The two cores share a 2 or 4-MByte L2 cache. All caches are writeback and non-inclusive. Each core contains:

- **L1 data cache, known as the data cache unit (DCU)** — The DCU can handle multiple outstanding cache misses and continue to service incoming stores and loads. It supports maintaining cache coherency. The DCU has the following specifications:
 - 32-KBytes size.
 - 8-way set associative.
 - 64-bytes line size.
- **Data translation lookaside buffer (DTLB)** — The DTLB in Intel Core microarchitecture implements two levels of hierarchy. Each level of the DTLB have multiple entries and can support either 4-KByte pages or large pages. The entries of the inner level (DTLB0) is used for loads. The entries in the outer level (DTLB1) support store operations and loads that missed DTLB0. All entries are 4-way associative. Here is a list of entries in each DTLB:
 - DTLB1 for large pages: 32 entries.
 - DTLB1 for 4-KByte pages: 256 entries.
 - DTLB0 for large pages: 16 entries.
 - DTLB0 for 4-KByte pages: 16 entries.

An DTLB0 miss and DTLB1 hit causes a penalty of 2 cycles. Software only pays this penalty if the DTLB0 is used in some dispatch cases. The delays associated with a miss to the DTLB1 and PMH are largely non-blocking due to the design of Intel Smart Memory Access.

- **Page miss handler (PMH)**
- **A memory ordering buffer (MOB)** — Which:
 - Enables loads and stores to issue speculatively and out of order.
 - Ensures retired loads and stores have the correct data upon retirement.
 - Ensures loads and stores follow memory ordering rules of the Intel 64 and IA-32 architectures.

The memory cluster of the Intel Core microarchitecture uses the following to speed up memory operations:

- 128-bit load and store operations.
- Data prefetching to L1 caches.
- Data prefetch logic for prefetching to the L2 cache.
- Store forwarding.
- Memory disambiguation.
- 8 fill buffer entries.
- 20 store buffer entries.
- Out of order execution of memory operations.
- Pipelined read-for-ownership operation (RFO).

For information on optimizing software for the memory cluster, see Section 3.6, “Optimizing Memory Accesses.”

E.3.4.1 Loads and Stores

The Intel Core microarchitecture can execute up to one 128-bit load and up to one 128-bit store per cycle, each to different memory locations. The microarchitecture enables execution of memory operations out of order with respect to other instructions and with respect to other memory operations.

Loads can:

- Issue before preceding stores when the load address and store address are known not to conflict.
- Be carried out speculatively, before preceding branches are resolved.
- Take cache misses out of order and in an overlapped manner.
- Issue before preceding stores, speculating that the store is not going to be to a conflicting address.

Loads cannot:

- Speculatively take any sort of fault or trap.
- Speculatively access the uncacheable memory type.

Faulting or uncacheable loads are detected and wait until retirement, when they update the programmer visible state. x87 and floating-point SIMD loads add 1 additional clock latency.

Stores to memory are executed in two phases:

- **Execution phase** — Prepares the store buffers with address and data for store forwarding. Consumes dispatch ports, which are ports 3 and 4.
- **Completion phase** — The store is retired to programmer-visible memory. It may compete for cache banks with executing loads. Store retirement is maintained as a background task by the memory order buffer, moving the data from the store buffers to the L1 cache.

E.3.4.2 Data Prefetch to L1 caches

Intel Core microarchitecture provides two hardware prefetchers to speed up data accessed by a program by prefetching to the L1 data cache:

- **Data cache unit (DCU) prefetcher** — This prefetcher, also known as the streaming prefetcher, is triggered by an ascending access to very recently loaded data. The processor assumes that this access is part of a streaming algorithm and automatically fetches the next line.
- **Instruction pointer (IP)- based strided prefetcher** — This prefetcher keeps track of individual load instructions. If a load instruction is detected to have a regular stride, then a prefetch is sent to the next address which is the sum of the current address and the stride. This prefetcher can prefetch forward or backward and can detect strides of up to half of a 4KB-page, or 2 KBytes.

Data prefetching works on loads only when the following conditions are met:

- Load is from writeback memory type.
- Prefetch request is within the page boundary of 4 Kbytes.
- No fence or lock is in progress in the pipeline.
- Not many other load misses are in progress.
- The bus is not very busy.
- There is not a continuous stream of stores.

DCU Prefetching has the following effects:

- Improves performance if data in large structures is arranged sequentially in the order used in the program.
- May cause slight performance degradation due to bandwidth issues if access patterns are sparse instead of local.
- On rare occasions, if the algorithm's working set is tuned to occupy most of the cache and unneeded prefetches evict lines required by the program, hardware prefetcher may cause severe performance degradation due to cache capacity of L1.

In contrast to hardware prefetchers relying on hardware to anticipate data traffic, software prefetch instructions relies on the programmer to anticipate cache miss traffic, software prefetch act as hints to bring a cache line of data into the desired levels of the cache hierarchy. The software-controlled prefetch is intended for prefetching data, but not for prefetching code.

E.3.4.3 Data Prefetch Logic

Data prefetch logic (DPL) prefetches data to the second-level (L2) cache based on past request patterns of the DCU from the L2. The DPL maintains two independent arrays to store addresses from the DCU: one for upstreams (12 entries) and one for down streams (4 entries). The DPL tracks accesses to one 4K byte page in each entry. If an accessed page is not in any of these arrays, then an array entry is allocated.

The DPL monitors DCU reads for incremental sequences of requests, known as streams. Once the DPL detects the second access of a stream, it prefetches the next cache line. For example, when the DCU requests the cache lines A and A+1, the DPL assumes the DCU will need cache line A+2 in the near future. If the DCU then reads A+2, the DPL prefetches cache line A+3. The DPL works similarly for "downward" loops.

The Intel Pentium M processor introduced DPL. The Intel Core microarchitecture added the following features to DPL:

- The DPL can detect more complicated streams, such as when the stream skips cache lines. DPL may issue 2 prefetch requests on every L2 lookup. The DPL in the Intel Core microarchitecture can run up to 8 lines ahead from the load request.
- DPL in the Intel Core microarchitecture adjusts dynamically to bus bandwidth and the number of requests. DPL prefetches far ahead if the bus is not busy, and less far ahead if the bus is busy.
- DPL adjusts to various applications and system configurations.

Entries for each core in a multi-core processor are handled separately.

E.3.4.4 Store Forwarding

If a load follows a store and reloads the data that the store writes to memory, the Intel Core microarchitecture can forward the data directly from the store to the load. This process, called store to load forwarding, saves cycles by enabling the load to obtain the data directly from the store operation instead of through memory.

The following rules must be met for store to load forwarding to occur:

- The store must be the last store to that address prior to the load.
- The store must be equal or greater in size than the size of data being loaded.
- The load cannot cross a cache line boundary.
- The load cannot cross an 8-Byte boundary.
- The load must be aligned to the start of the store address, except for the following exceptions:
 - An aligned 64-bit store may forward either of its 32-bit halves.
 - An aligned 128-bit store may forward any of its 32-bit quarters.
 - An aligned 128-bit store may forward either of its 64-bit halves.

Software can use the exceptions to the last rule to move complex structures without losing the ability to forward the subfields.

In Enhanced Intel Core microarchitecture, the alignment restrictions to permit store forwarding to proceed have been relaxed. Enhanced Intel Core microarchitecture permits store-forwarding to proceed in several situations that the succeeding load is not aligned to the preceding store. Figure E-7 shows six situations (in gradient-filled background) of store-forwarding that are permitted in Enhanced Intel Core microarchitecture but not in Intel Core microarchitecture. The cases with backward slash background depicts store-forwarding that can proceed in both Intel Core microarchitecture and Enhanced Intel Core microarchitecture.

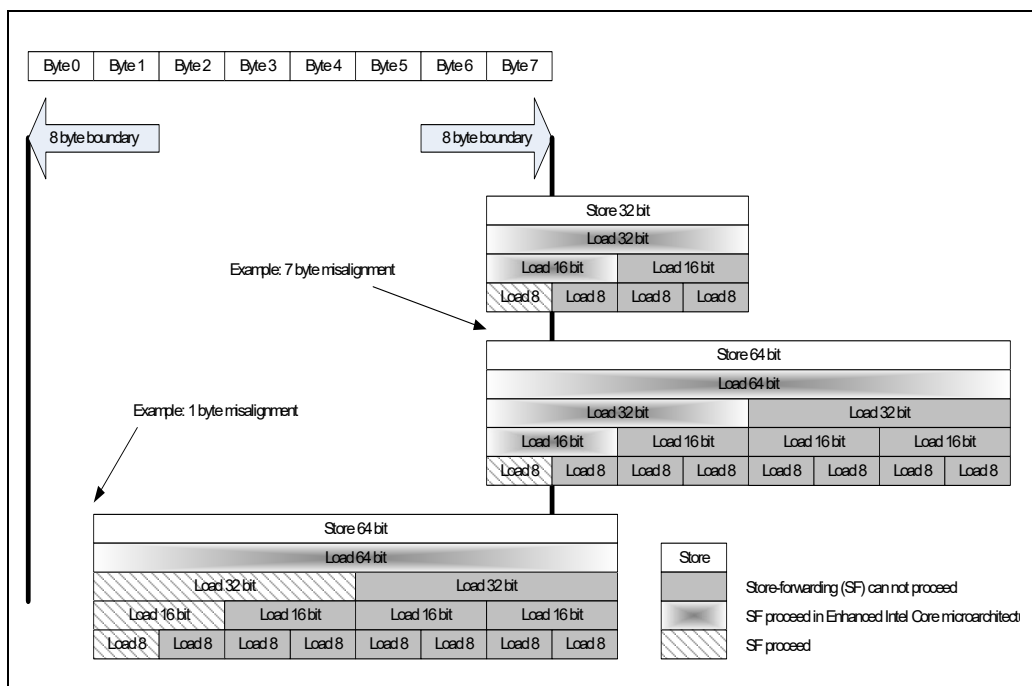

Figure E-7. Store-Forwarding Enhancements in Enhanced Intel Core Microarchitecture

E.3.4.5 Memory Disambiguation

Refer to the “Memory Disambiguation” details in Section E.2.5.2, “L1 DCache”.

E.3.5 Intel® Advanced Smart Cache

The Intel Core microarchitecture optimized a number of features for two processor cores on a single die. The two cores share a second-level cache and a bus interface unit, collectively known as Intel Advanced Smart Cache. This section describes the components of Intel Advanced Smart Cache. Figure E-8 illustrates the architecture of the Intel Advanced Smart Cache.

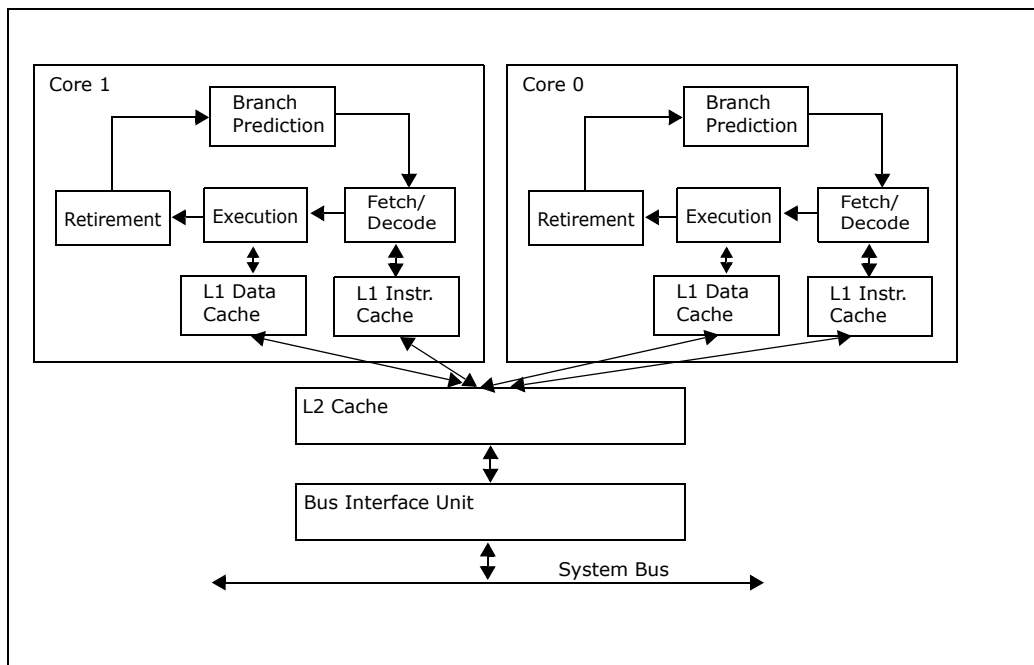

Figure E-8. Intel Advanced Smart Cache Architecture

Table E-23 details the parameters of caches in the Intel Core microarchitecture. For information on enumerating the cache hierarchy identification using the deterministic cache parameter leaf of CPUID instruction, see the *Intel® 64 and IA-32 Architectures Software Developer’s Manual, Volume 2A*.

Table E-23. Cache Parameters of Processors based on Intel Core Microarchitecture

Level	Capacity	Associativity (ways)	Line Size (bytes)	Access Latency (clocks)	Access Throughput (clocks)	Write Update Policy
First Level	32 KB	8	64	3	1	Writeback
Instruction	32 KB	8	N/A	N/A	N/A	N/A
Second Level (Shared L2) ¹	2, 4 MB	8 or 16	64	14 ²	2	Writeback
Second Level (Shared L2) ³	3, 6 MB	12 or 24	64	15 ²	2	Writeback
Third Level ⁴	8, 12, 16 MB	16	64	~110	12	Writeback

NOTES:

1. Intel Core microarchitecture (CUID signature DisplayFamily = 06H, DisplayModel = 0FH).
2. Software-visible latency will vary depending on access patterns and other factors.
3. Enhanced Intel Core microarchitecture (CUID signature DisplayFamily = 06H, DisplayModel = 17H or 1DH).
4. Enhanced Intel Core microarchitecture (CUID signature DisplayFamily = 06H, DisplayModel = 1DH).

E.3.5.1 Loads

When an instruction reads data from a memory location that has write-back (WB) type, the processor looks for the cache line that contains this data in the caches and memory in the following order:

1. DCU of the initiating core.
2. DCU of the other core and second-level cache.
3. System memory.

The cache line is taken from the DCU of the other core only if it is modified, ignoring the cache line availability or state in the L2 cache.

Table E-24 shows the characteristics of fetching the first four bytes of different localities from the memory cluster. The latency column provides an estimate of access latency. However, the actual latency can vary depending on the load of cache, memory components, and their parameters.

Table E-24. Characteristics of Load and Store Operations in Intel Core Microarchitecture

Data Locality	Load		Store	
	Latency	Throughput	Latency	Throughput
DCU	3	1	2	1
DCU of the other core in modified state	14 + 5.5 bus cycles	14 + 5.5 bus cycles	14 + 5.5 bus cycles	
2nd-level cache	14	3	14	3
Memory	14 + 5.5 bus cycles + memory	Depends on bus read protocol	14 + 5.5 bus cycles + memory	Depends on bus write protocol

Sometimes a modified cache line has to be evicted to make space for a new cache line. The modified cache line is evicted in parallel to bringing the new data and does not require additional latency. However, when data is written back to memory, the eviction uses cache bandwidth and possibly bus bandwidth as well. Therefore, when multiple cache misses require the eviction of modified lines within a short time, there is an overall degradation in cache response time.

E.3.5.2 Stores

When an instruction writes data to a memory location that has WB memory type, the processor first ensures that the line is in Exclusive or Modified state in its own DCU. The processor looks for the cache line in the following locations, in the specified order:

1. DCU of initiating core.
2. DCU of the other core and L2 cache.
3. System memory.

The cache line is taken from the DCU of the other core only if it is modified, ignoring the cache line availability or state in the L2 cache. After reading for ownership is completed, the data is written to the first-level data cache and the line is marked as modified.

Reading for ownership and storing the data happens after instruction retirement and follows the order of retirement. Therefore, the store latency does not effect the store instruction itself. However, several

sequential stores may have cumulative latency that can affect performance. Table E-24 presents store latencies depending on the initial cache line location.

E.4 NEHALEM MICROARCHITECTURE

Nehalem microarchitecture provides the foundation for many innovative features of Intel Core i7 processors and Intel Xeon processor 3400, 5500, and 7500 series. It builds on the success of 45 nm enhanced Intel Core microarchitecture and provides the following feature enhancements:

- **Enhanced processor core**
 - Improved branch prediction and recovery from misprediction.
 - Enhanced loop streaming to improve front end performance and reduce power consumption.
 - Deeper buffering in out-of-order engine to extract parallelism.
 - Enhanced execution units to provide acceleration in CRC, string/text processing and data shuffling.
- **Hyper-Threading Technology**
 - Provides two hardware threads (logical processors) per core.
 - Takes advantage of 4-wide execution engine, large L3, and massive memory bandwidth.
- **Smart Memory Access**
 - Integrated memory controller provides low-latency access to system memory and scalable memory bandwidth.
 - New cache hierarchy organization with shared, inclusive L3 to reduce snoop traffic.
 - Two level TLBs and increased TLB size.
 - Fast unaligned memory access.
- **Dedicated Power management Innovations**
 - Integrated microcontroller with optimized embedded firmware to manage power consumption.
 - Embedded real-time sensors for temperature, current, and power.
 - Integrated power gate to turn off/on per-core power consumption.
 - Versatility to reduce power consumption of memory, link subsystems.

Westmere microarchitecture is a 32 nm version of Nehalem microarchitecture. All of the features of latter also apply to the former.

E.4.1 Microarchitecture Pipeline

Nehalem microarchitecture continues the four-wide microarchitecture pipeline pioneered by the 65nm Intel Core microarchitecture. Figure E-9 illustrates the basic components of the pipeline of Nehalem microarchitecture as implemented in Intel Core i7 processor, only two of the four cores are sketched in the Figure E-9 pipeline diagram.

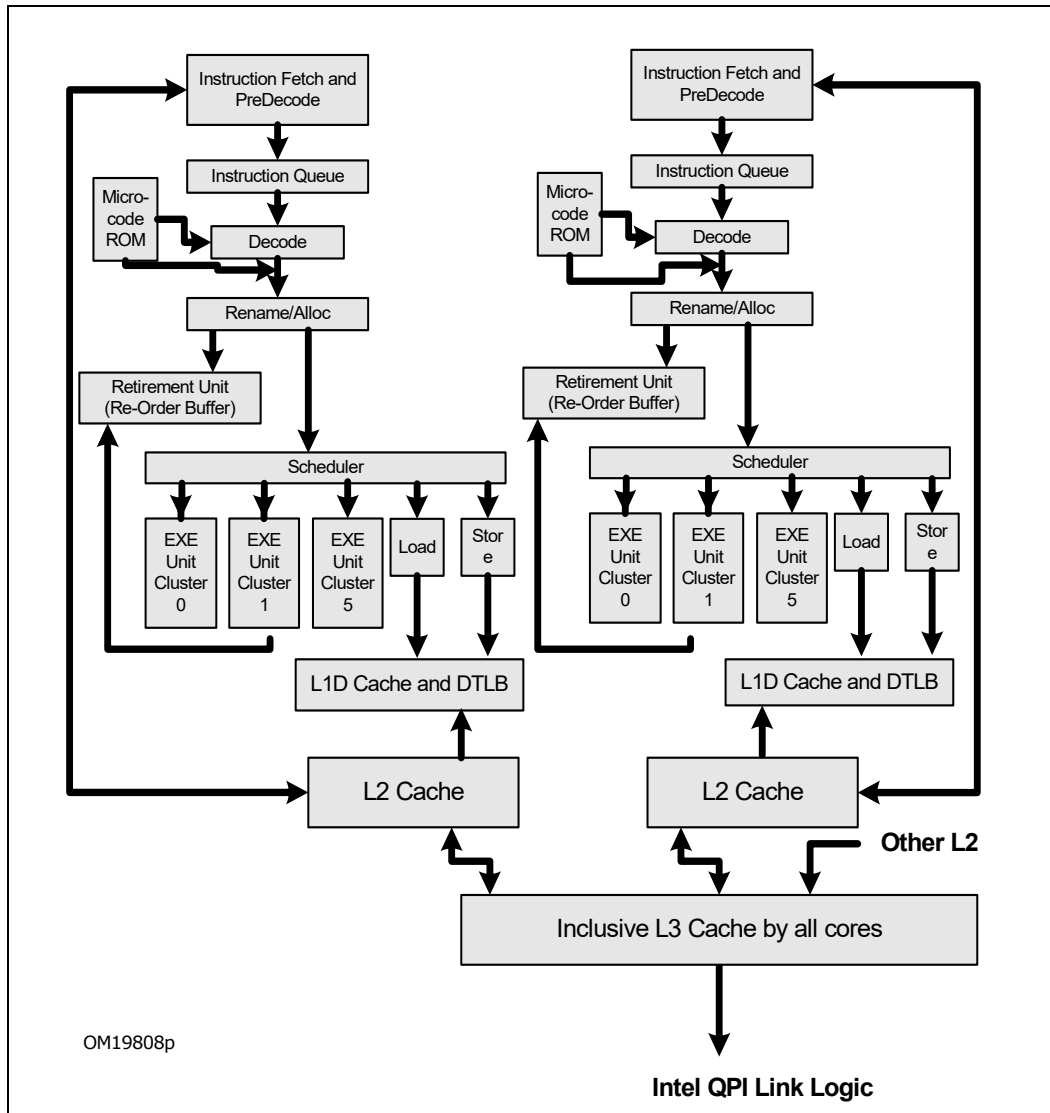

Figure E-9. Nehalem Microarchitecture Pipeline Functionality

The length of the pipeline in Nehalem microarchitecture is two cycles longer than its predecessor in the 45 nm Intel Core 2 processor family, as measured by branch misprediction delay. The front end can decode up to 4 instructions in one cycle and supports two hardware threads by decoding the instruction streams between two logical processors in alternate cycles. The front end includes enhancement in branch handling, loop detection, MSR/MSR-MP throughput, etc. These are discussed in subsequent sections.

The scheduler (or reservation station) can dispatch up to six micro-ops in one cycle through six issue ports (five issue ports are shown in Figure E-9; store operation involves separate ports for store address and store data but is depicted as one in the diagram).

The out-of-order engine has many execution units that are arranged in three execution clusters shown in Figure E-9. It can retire four micro-ops in one cycle, same as its predecessor.

E.4.2 Front End Overview

Figure E-10 depicts the key components of the front end of the microarchitecture. The instruction fetch unit (IFU) can fetch up to 16 bytes of aligned instruction bytes each cycle from the instruction cache to the instruction length decoder (ILD). The instruction queue (IQ) buffers the ILD-processed instructions and can deliver up to four instructions in one cycle to the instruction decoder.

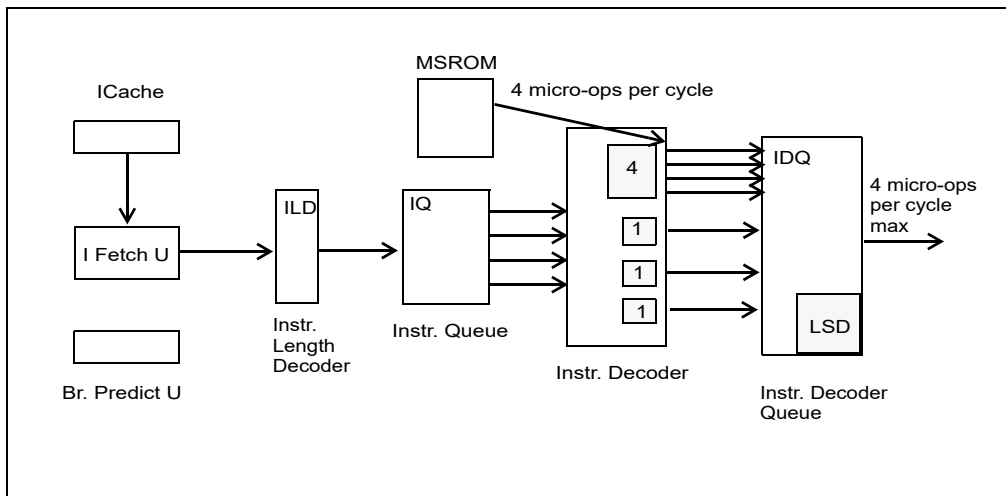

Figure E-10. Front End of Nehalem Microarchitecture

The instruction decoder has three decoder units that can decode one simple instruction per cycle per unit. The other decoder unit can decode one instruction every cycle, either simple instruction or complex instruction made up of several micro-ops. Instructions made up of more than four micro-ops are delivered from the MSROM. Up to four micro-ops can be delivered each cycle to the instruction decoder queue (IDQ).

The loop stream detector is located inside the IDQ to improve power consumption and front end efficiency for loops with a short sequence of instructions.

The instruction decoder supports micro-fusion to improve front end throughput, increase the effective size of queues in the scheduler and re-order buffer (ROB). The rules for micro-fusion are similar to those of Intel Core microarchitecture.

The instruction queue also supports macro-fusion to combine adjacent instructions into one micro-ops where possible. In previous generations of Intel Core microarchitecture, macro-fusion support for CMP/Jcc sequence is limited to the CF and ZF flag, and macro-fusion is not supported in 64-bit mode.

In Nehalem microarchitecture, macro-fusion is supported in 64-bit mode, and the following instruction sequences are supported:

- CMP or TEST can be fused when comparing (unchanged):
 - REG-REG. For example: `CMP EAX,ECX; JZ label`
 - REG-IMM. For example: `CMP EAX,0x80; JZ label`
 - REG-MEM. For example: `CMP EAX,[ECX]; JZ label`
 - MEM-REG. For example: `CMP [EAX],ECX; JZ label`
- TEST can fused with all conditional jumps (unchanged).

- CMP can be fused with the following conditional jumps. These conditional jumps check carry flag (CF) or zero flag (ZF). The list of macro-fusion-capable conditional jumps are (unchanged):

JA or JNBE
 JAE or JNB or JNC
 JE or JZ
 JNA or JBE
 JNAE or JC or JB
 JNE or JNZ

- CMP can be fused with the following conditional jumps in Nehalem microarchitecture (this is an enhancement):

JL or JNGE
 JGE or JNL
 JLE or JNG
 JG or JNLE

The hardware improves branch handling in several ways. Branch target buffer has increased to increase the accuracy of branch predictions. Renaming is supported with return stack buffer to reduce mispredictions of return instructions in the code. Furthermore, hardware enhancement improves the handling of branch misprediction by expediting resource reclamation so that the front end would not be waiting to decode instructions in an architected code path (the code path in which instructions will reach retirement) while resources were allocated to executing mispredicted code path. Instead, new micro-ops stream can start forward progress as soon as the front end decodes the instructions in the architected code path.

E.4.3 Execution Engine

The IDQ (Figure E-10) delivers micro-op stream to the allocation/rename stage (Figure E-9) of the pipeline. The out-of-order engine supports up to 128 micro-ops in flight. Each micro-op must be allocated with the following resources: an entry in the re-order buffer (ROB), an entry in the reservation station (RS), and a load/store buffer if a memory access is required.

The allocator also renames the register file entry of each micro-op in flight. The input data associated with a micro-op are generally either read from the ROB or from the retired register file.

The RS is expanded to 36 entry deep (compared to 32 entries in previous generation). It can dispatch up to six micro-ops in one cycle if the micro-ops are ready to execute. The RS dispatch a micro-op through an issue port to a specific execution cluster, each cluster may contain a collection of integer/FP/SIMD execution units.

The result from the execution unit executing a micro-op is written back to the register file, or forwarded through a bypass network to a micro-op in-flight that needs the result. Nehalem microarchitecture can support write back throughput of one register file write per cycle per port. The bypass network consists of three domains of integer/FP/SIMD. Forwarding the result within the same bypass domain from a producer micro-op to a consumer micro is done efficiently in hardware without delay. Forwarding the result across different bypass domains may be subject to additional bypass delays. The bypass delays may be visible to software in addition to the latency and throughput characteristics of individual execution units. The bypass delays between a producer micro-op and a consumer micro-op across different bypass domains are shown in Table E-25.

Table E-25. Bypass Delay Between Producer and Consumer Micro-ops (cycles)

	FP	Integer	SIMD
FP	0	2	2
Integer	2	0	1
SIMD	2	1	0

E.4.3.1 Issue Ports and Execution Units

Table E-26 summarizes the key characteristics of the issue ports and the execution unit latency/throughputs for common operations in the microarchitecture.

Table E-26. Issue Ports of Nehalem Microarchitecture

Port	Executable operations	Latency	Throughput	Domain	Comment
Port 0	Integer ALU	1	1	Integer	
	Integer Shift	1	1		
Port 0	Integer SIMD ALU	1	1	SIMD	
	Integer SIMD Shuffle	1	1		
Port 0	Single-precision (SP) FP MUL	4	1	FP	
	Double-precision FP MUL	5	1		
	FP MUL (X87)	5	1		
	FP/SIMD/SSE2 Move and Logic	1	1		
	FP Shuffle	1	1		
	DIV/SQRT	1	1		
Port 1	Integer ALU	1	1	Integer	
	Integer LEA	1	1		
	Integer Mul	3	1		
Port 1	Integer SIMD MUL	1	1	SIMD	
	Integer SIMD Shift	1	1		
	PSAD	3	1		
	StringCompare				
Port 1	FP ADD	3	1	FP	
Port 2	Integer loads	4	1	Integer	
Port 3	Store address	5	1	Integer	
Port 4	Store data			Integer	
Port 5	Integer ALU	1	1	Integer	
	Integer Shift	1	1		
	Jmp	1	1		
Port 5	Integer SIMD ALU	1	1	SIMD	
	Integer SIMD Shuffle	1	1		

Table E-26. Issue Ports of Nehalem Microarchitecture (Contd.)

Port	Executable operations	Latency	Throughput	Domain	Comment
Port 5	FP/SIMD/SSE2 Move and Logic	1	1	FP	

E.4.4 Cache and Memory Subsystem

Nehalem microarchitecture contains an instruction cache, a first-level data cache and a second-level unified cache in each core (see Figure E-9). Each physical processor may contain several processor cores and a shared collection of sub-systems that are referred to as “uncore”. Specifically in Intel Core i7 processor, the uncore provides a unified third-level cache shared by all cores in the physical processor, Intel QuickPath Interconnect links and associated logic. The L1 and L2 caches are writeback and non-inclusive.

The shared L3 cache is writeback and inclusive, such that a cache line that exists in either L1 data cache, L1 instruction cache, unified L2 cache also exists in L3. The L3 is designed to use the inclusive nature to minimize snoop traffic between processor cores. Table E-27 lists characteristics of the cache hierarchy. The latency of L3 access may vary as a function of the frequency ratio between the processor and the uncore sub-system.

Table E-27. Cache Parameters of Intel Core i7 Processors

Level	Capacity	Associativity (ways)	Line Size (bytes)	Access Latency (clocks)	Access Throughput (clocks)	Write Update Policy
First Level Data	32 KB	8	64	4	1	Writeback
Instruction	32 KB	4	N/A	N/A	N/A	N/A
Second Level	256KB	8	64	10 ¹	Varies	Writeback
Third Level (Shared L3) ²	8MB	16	64	35-40+ ²	Varies	Writeback

NOTES:

1. Software-visible latency will vary depending on access patterns and other factors.
2. Minimal L3 latency is 35 cycles if the frequency ratio between core and uncore is unity.

Nehalem microarchitecture implements two levels of translation lookaside buffer (TLB). The first level consists of separate TLBs for data and code. DTLB0 handles address translation for data accesses, it provides 64 entries to support 4KB pages and 32 entries for large pages. The ITLB provides 64 entries (per thread) for 4KB pages and 7 entries (per thread) for large pages.

The second level TLB (STLB) handles both code and data accesses for 4KB pages. It support 4KB page translation operation that missed DTLB0 or ITLB. All entries are 4-way associative. Here is a list of entries in each DTLB:

- STLB for 4-KByte pages: 512 entries (services both data and instruction look-ups).
- DTLB0 for large pages: 32 entries.
- DTLB0 for 4-KByte pages: 64 entries.

An DTLB0 miss and STLB hit causes a penalty of 7cycles. Software only pays this penalty if the DTLB0 is used in some dispatch cases. The delays associated with a miss to the STLB and PMH are largely non-blocking.

E.4.5 Load and Store Operation Enhancements

The memory cluster of Nehalem microarchitecture provides the following enhancements to speed up memory operations:

- Peak issue rate of one 128-bit load and one 128-bit store operation per cycle.
- Deeper buffers for load and store operations: 48 load buffers, 32 store buffers and 10 fill buffers.
- Fast unaligned memory access and robust handling of memory alignment hazards.
- Improved store-forwarding for aligned and non-aligned scenarios.
- Store forwarding for most address alignments.

E.4.5.1 Efficient Handling of Alignment Hazards

The cache and memory subsystems handles a significant percentage of instructions in every workload. Different address alignment scenarios will produce varying performance impact for memory and cache operations. For example, 1-cycle throughput of L1 (see Table E-28) generally applies to naturally-aligned loads from L1 cache. But using unaligned load instructions (e.g. MOVUPS, MOVUPD, MOVDQU, etc.) to access data from L1 will experience varying amount of delays depending on specific microarchitectures and alignment scenarios.

Table E-28. Performance Impact of Address Alignments of MOVDQU from L1

Throughput (cycle)	Intel Core i7 Processor	45 nm Intel Core Microarchitecture	65 nm Intel Core Microarchitecture
Alignment Scenario	06_1AH	06_17H	06_0FH
16B aligned	1	2	2
Not-16B aligned, not cache split	1	~2	~2
Split cache line boundary	~4.5	~20	~20

Table E-28 lists approximate throughput of issuing MOVDQU instructions with different address alignment scenarios to load data from the L1 cache. If a 16-byte load spans across cache line boundary, previous microarchitecture generations will experience significant software-visible delays.

Nehalem microarchitecture provides hardware enhancements to reduce the delays of handling different address alignment scenarios including cache line splits.

E.4.5.2 Store Forwarding Enhancement

When a load follows a store and reloads the data that the store writes to memory, the microarchitecture can forward the data directly from the store to the load in many cases. This situation, called store to load forwarding, saves several cycles by enabling the load to obtain the data directly from the store operation instead of through the memory system.

Several general rules must be met for store to load forwarding to proceed without delay:

- The store must be the last store to that address prior to the load.
- The store must be equal or greater in size than the size of data being loaded.
- The load data must be completely contained in the preceding store.

Specific address alignment and data sizes between the store and load operations will determine whether a store-forward situation may proceed with data forwarding or experience a delay via the cache/memory sub-system. The 45 nm Enhanced Intel Core microarchitecture offers more flexible address alignment and data sizes requirement than previous microarchitectures. Nehalem microarchitecture offers additional enhancement with allowing more situations to forward data expeditiously.

The store-forwarding situations for with respect to store operations of 16 bytes are illustrated in Figure E-11.



Figure E-11. Store-Forwarding Scenarios of 16-Byte Store Operations

Nehalem microarchitecture allows store-to-load forwarding to proceed regardless of store address alignment (The white space in the diagram does not correspond to an applicable store-to-load scenario). Figure E-12 illustrates situations for store operation of 8 bytes or less.

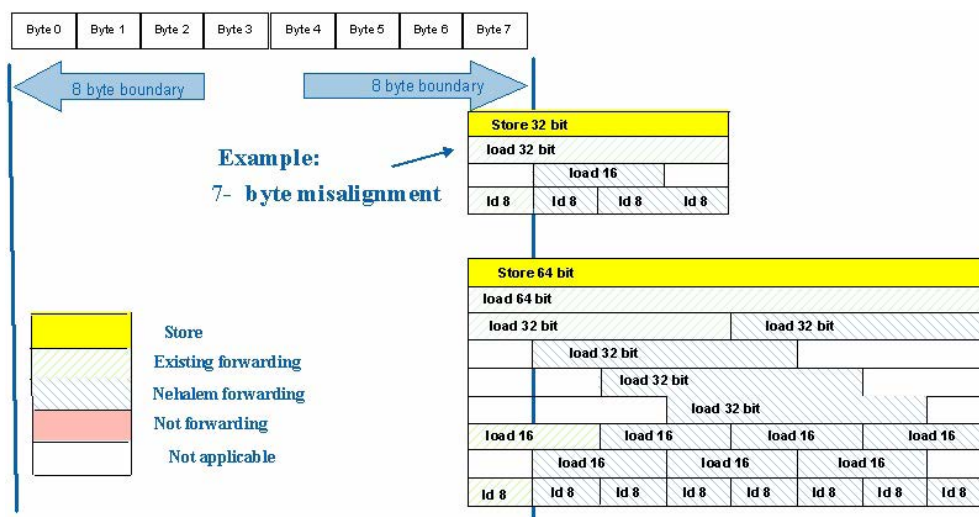

Figure E-12. Store-Forwarding Enhancement in Nehalem Microarchitecture

E.4.6 REP String Enhancement

REP prefix in conjunction with MOVSB/STOSB instruction and a count value in ECX are frequently used to implement library functions such as memcpy()/memset(). These are referred to as "REP string" instructions. Each iteration of these instructions can copy/write constant a value in byte/word/dword/qword granularity. The performance characteristics of using REP string can be attributed to two components: startup overhead and data transfer throughput.

The two components of performance characteristics of REP String varies further depending on granularity, alignment, and/or count values. Generally, MOVSB is used to handle very small chunks of data. Therefore, processor implementation of REP MOVSB is optimized to handle ECX < 4. Using REP MOVSB with ECX > 3 will achieve low data throughput due to not only byte-granular data transfer but also additional startup overhead. The latency for MOVSB, is 9 cycles if ECX < 4; otherwise REP MOVSB with ECX > 9 have a 50-cycle startup cost.

For REP string of larger granularity data transfer, as ECX value increases, the startup overhead of REP String exhibit step-wise increase:

- Short string (ECX ≤ 12): the latency of REP MOVSW/MOVSD/MOVSQ is about 20 cycles.
- Fast string (ECX ≥ 76: excluding REP MOVSB): the processor implementation provides hardware optimization by moving as many pieces of data in 16 bytes as possible. The latency of REP string latency will vary if one of the 16-byte data transfer spans across cache line boundary:
 - Split-free: the latency consists of a startup cost of about 40 cycles and each 64 bytes of data adds 4 cycles.
 - Cache splits: the latency consists of a startup cost of about 35 cycles and each 64 bytes of data adds 6 cycles.
- Intermediate string lengths: the latency of REP MOVSW/MOVSD/MOVSQ has a startup cost of about 15 cycles plus one cycle for each iteration of the data movement in word/dword/qword.

Nehalem microarchitecture improves the performance of REP strings significantly over previous microarchitectures in several ways:

- Startup overhead have been reduced in most cases relative to previous microarchitecture.
- Data transfer throughput are improved over previous generation.

- In order for REP string to operate in “fast string” mode, previous microarchitectures requires address alignment. In Nehalem microarchitecture, REP string can operate in “fast string” mode even if the address is not aligned to 16 bytes.

E.4.7 Enhancements for System Software

In addition to microarchitectural enhancements that can benefit both application-level and system-level software, Nehalem microarchitecture enhances several operations that primarily benefit system software.

Lock primitives: Synchronization primitives using the Lock prefix (e.g. XCHG, CMPXCHG8B) executes with significantly reduced latency than previous microarchitectures.

VMM overhead improvements: VMX transitions between a Virtual Machine (VM) and its supervisor (the VMM) can take thousands of cycle each time on previous microarchitectures. The latency of VMX transitions has been reduced in processors based on Nehalem microarchitecture.

E.4.8 Efficiency Enhancements for Power Consumption

Nehalem microarchitecture is not only designed for high performance and power-efficient performance under wide range of loading situations, it also features enhancement for low power consumption while the system idles. Nehalem microarchitecture supports processor-specific C6 states, which have the lowest leakage power consumption that OS can manage through ACPI and OS power management mechanisms.

E.4.9 Hyper-Threading Technology Support in Nehalem Microarchitecture

Nehalem microarchitecture supports Hyper-Threading Technology (HT). Its implementation of HT provides two logical processors sharing most execution/cache resources in each core. The HT implementation in Nehalem microarchitecture differs from previous generations of HT implementations using Intel NetBurst microarchitecture in several areas:

- Nehalem microarchitecture provides four-wide execution engine, more functional execution units coupled to three issue ports capable of issuing computational operations.
- Nehalem microarchitecture supports integrated memory controller that can provide peak memory bandwidth of up to 25.6 GB/sec in Intel Core i7 processor.
- Deeper buffering and enhanced resource sharing/partition policies:
 - Replicated resource for HT operation: register state, renamed return stack buffer, large-page ITLB.
 - Partitioned resources for HT operation: load buffers, store buffers, re-order buffers, small-page ITLB are statically allocated between two logical processors.
 - Competitively-shared resource during HT operation: the reservation station, cache hierarchy, fill buffers, both DTLB0 and STLB.
 - Alternating during HT operation: front end operation generally alternates between two logical processors to ensure fairness.
 - HT unaware resources: execution units.

APPENDIX F

EARLIER GENERATIONS OF INTEL ATOM[®] MICROARCHITECTURE AND SOFTWARE OPTIMIZATION

F.1 OVERVIEW

45 nm Intel Atom processors introduced Intel Atom microarchitecture. The same microarchitecture also used in 32 nm Intel Atom processors. This chapter covers a brief overview the Intel Atom microarchitecture, and specific coding techniques for software whose primary targets are processors based on the Intel Atom microarchitecture. The key features of Intel Atom processors to support low power consumption and efficient performance include:

- Enhanced Intel SpeedStep[®] Technology enables operating system (OS) to program a processor to transition to lower frequency and/or voltage levels while executing a workload.
- Support deep power down technology to reduces static power consumption by turning off power to cache and other sub-systems in the processor.
- Intel Hyper-Threading Technology providing two logical processor for multi-tasking and multi-threading workloads.
- Support Single-instruction multiple-data extensions up to SSE3 and SSSE3.
- Support for Intel 64 and IA-32 architecture.

The Intel Atom microarchitecture is designed to support the general performance requirements of modern workloads within the power-consumption envelop of small form-factor and/or thermally-constrained environments.

F.2 INTEL ATOM[®] MICROARCHITECTURE

Intel Atom microarchitecture achieves efficient performance and low power operation with a two-issue wide, in-order pipeline that support Hyper-Threading Technology. The in-order pipeline differs from out-of-order pipelines by treating an IA-32 instruction with a memory operand as a single pipeline operation instead of multiple micro-operations.

The basic block diagram of the Intel Atom microarchitecture pipeline is shown in Figure F-1.

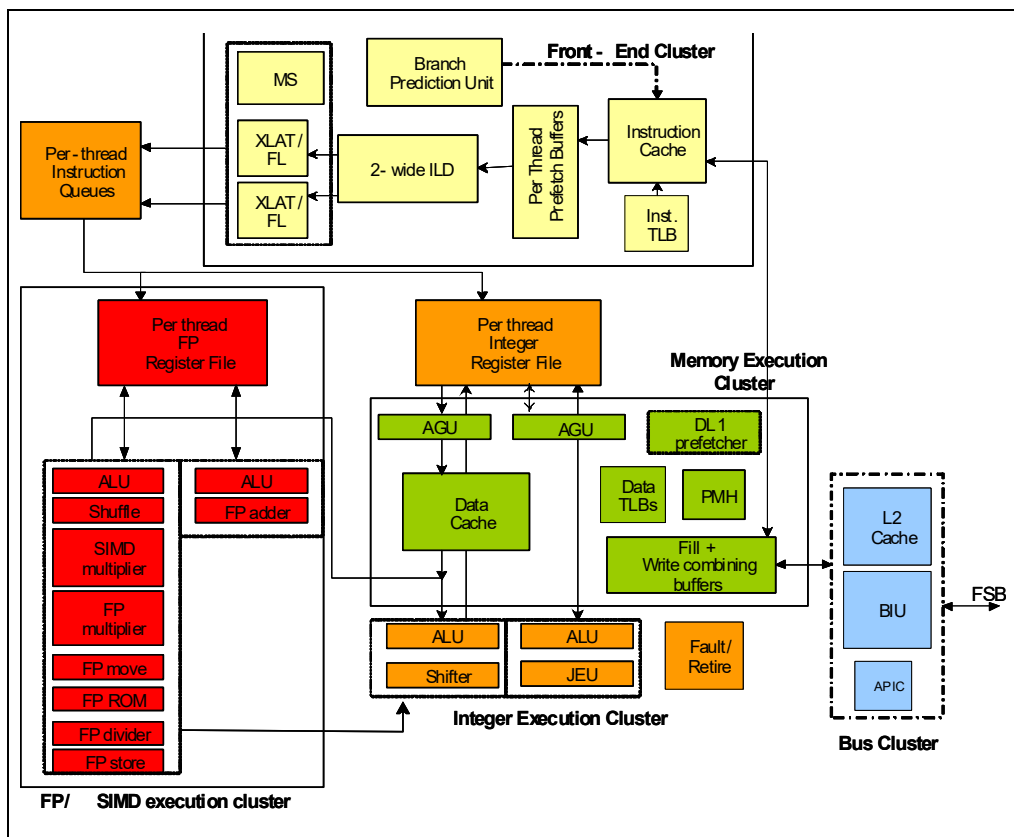

Figure F-1. Intel Atom® Microarchitecture Pipeline

The front end features a power-optimized pipeline, including:

- 32KB, 8-way set associative, first-level instruction cache.
- Branch prediction units and ITLB.
- Two instruction decoders, each can decode up to one instruction per cycle.

The front end can deliver up to two instructions per cycle to the instruction queue for scheduling. The scheduler can issue up to two instructions per cycle to the integer or SIMD/FP execution clusters via two issue ports.

Each of the two issue ports can dispatch an instruction per cycle to the integer cluster or the SIMD/FP cluster to execute. The port-bindings of the integer and SIMD/FP clusters have the following features:

- Integer execution cluster:
 - Port 0: ALU0, Shift/Rotate unit, Load/Store.
 - Port 1: ALU1, Bit processing unit, jump unite and LEA.
 - Effective "load-to-use" latency of 0 cycle.
- SIMD/FP execution cluster:
 - Port 0: SIMD ALU, Shuffle unit, SIMD/FP multiply unit, Divide unit, (support IMUL, IDIV).
 - Port 1: SIMD ALU, FP Adder.
 - The two SIMD ALUs and the shuffle unit in the SIMD/FP cluster are 128-bit wide, but 64-bit integer SIMD computation is restricted to port 0 only.
 - FP adder can execute ADDPS/SUBPS in 128-bit data path, data path for other FP add operations are 64-bit wide.

- Safe Instruction Recognition algorithm for FP/SIMD execution allow younger, short-latency integer instruction to execute without being blocked by older FP/SIMD instruction that might cause exception.
- FP multiply pipe also supports memory loads.
- FP ADD instructions with memory load reference can use both ports to dispatch.

The memory execution sub-system (MEU) can support 48-bit linear address for Intel 64 Architecture, either 32-bit or 36-bit physical addressing modes. The MEU provides:

- 24KB first level data cache.
- Hardware prefetching for L1 data cache.
- Two levels of DTLB for 4KByte and larger paging structure.
- Hardware pagewalker to service DTLB and ITLB misses.
- Two address generation units (port 0 supports loads and stores, port 1 supports LEA and stack operations).
- Store-forwarding support for integer operations.
- 8 write combining buffers.

The bus logic sub-system provides:

- 512KB, 8-way set associative, unified L2 cache.
- Hardware prefetching for L2 and interface logic to the front side bus.

F.2.1 Hyper-Threading Technology Support in Intel Atom® Microarchitecture

The instruction queue is statically partitioned for scheduling instruction execution from two threads. The scheduler is able to pick one instruction from either thread and dispatch to either of port 0 or port 1 for execution. The hardware makes selection choice on fetching/decoding/dispatching instructions between two threads based on criteria of fairness as well as each thread's readiness to make forward progress.

F.3 CODING RECOMMENDATIONS FOR INTEL ATOM® MICROARCHITECTURE

Instruction scheduling heuristics and coding techniques that apply to out-of-order microarchitectures may not deliver optimal performance on an in-order microarchitecture. Likewise instruction scheduling heuristics and coding techniques for an in-order pipeline like Intel Atom microarchitecture may not achieve optimal performance on out-of-order microarchitectures. This section covers specific coding recommendations for software whose primary deployment targets are processors based on Intel Atom microarchitecture.

F.3.1 Optimization for Front End of Intel Atom® Microarchitecture

The two decoders in the front end of Intel Atom microarchitecture can handle most instructions in the Intel 64 and IA-32 architecture. Some instructions dealing with complicated operations require the use of an MSROM in the front end. Instructions that go through the two decoders generally can be decoded by either decoder unit of the front end in most cases. Instructions that must use the MSROM or conditions that cause the front end to re-arrange decoder assignments will experience a delay in the front end.

Software can use specific performance monitoring events to detect instruction sequences and/or conditions that cause front end to re-arrange decoder assignment.

Assembly/Compiler Coding Rule 1. (MH impact, ML generality) For Intel Atom processors, minimize the presence of complex instructions requiring MSROM to take advantage the optimal decode bandwidth provided by the two decode units.

Using the performance monitoring events "MACRO_INSTS.NON_CISC_DECODED" and "MACRO_INSTS.CISC_DECODED" can be used to evaluate the percentage instructions in a workload that required MSROM.

Assembly/Compiler Coding Rule 2. (M impact, H generality) For Intel Atom processors, keeping the instruction working set footprint small will help the front end to take advantage the optimal decode bandwidth provided by the two decode units.

Assembly/Compiler Coding Rule 3. (MH impact, ML generality) For Intel Atom processors, avoiding back-to-back X87 instructions will help the front end to take advantage the optimal decode bandwidth provided by the two decode units.

Using the performance monitoring events "DECODE_RESTRICTION" can count the number of occurrences in a workload that encountered delays causing reduction of decode throughput.

In general the front end restrictions are not typical a performance limiter until the retired "cycle per instruction" becomes less than unity (maximum theoretical retirement throughput corresponds to CPI of 0.5). To reach CPI below unity, it is important to generate instruction sequences that go through the front end as instruction pairs decodes in parallel by the two decoders. After the front end, the scheduler and execution hardware do not need to dispatch the decode pairings through port 0 and port 1 in the same order.

The decoders cannot decode past a jump instruction, so jumps should be paired as the second instruction in a decoder-optimized pairing. The front end can only handle one X87 instruction per cycle, and only decoder unit 0 can request a transfer to use MSROM. Instructions that are longer than 8 bytes or having more than three prefixes will results in a MSROM transfer, experiencing two cycles of delay in the front end.

Instruction lengths and alignment can impact decode throughput. The prefetching buffers inside the front end imposes a throughput limit that if the number of bytes being decoded in any 7-cycle window exceeds 48 bytes, the front end will experience a delay to wait for a buffer. Additionally, every time an instruction pair crosses 16 byte boundary, it requires the front end buffer to be held on for at least one more cycle. So instruction alignment crossing 16 byte boundary is highly problematic.

Instruction alignment can be improved using a combination of an ignore prefix and an instruction.

Example F-1. Instruction Pairing and Alignment to Optimize Decode Throughput on Intel Atom® Microarchitecture

Address	Instruction Bytes	Disassembly
7FFFFDF0	0F594301	mulps xmm0, [ebx+ 01h]
7FFFFDF4	8341FFFF	add dword ptr [ecx-01h], -1
7FFFFDF8	83C2FF	add edx, , -1
7FFFFDFB	64	; FS prefix override is ignored, improves code alignment
7FFFFDFC	F20f58E4	add xmm4, xmm4
7FFFFE00	0F594B11	mulps xmm1, [ebx+ 11h]
7FFFFE04	8369EFFF	sub dword ptr [ecx- 11h], -1
7FFFFE08	83EAFB	sub edx, -1
7FFFFE0B	64	; FS prefix override is ignored, improves code alignment
7FFFFE0C	F20F58ED	addsd xmm5, xmm5
7FFFFE10	0F595301	mulps xmm2, [ebx +1]

Example F-1. Instruction Pairing and Alignment to Optimize Decode Throughput on Intel Atom® Microarchitecture

Address	Instruction Bytes	Disassembly
7FFFFFFE14	8341DFFF	add dword ptr [ecx-21H], -1
7FFFFFFE18	83C2FF	add edx, -1
7FFFFFFE1B	64	; FS prefix override is ignored, improves code alignment
7FFFFFFE1C	F20F58F6	addssd xmm6, xmm6
7FFFFFFE20	0F595B11	mulps xmm3, [ebx+ 11h]
7FFFFFFE24	8369CFFF	sub dword ptr [ecx- 31h], -1
7FFFFFFE28	83EAFB	sub edx, -1

When a small loop contains some long-latency operation inside, loop unrolling may be considered as a technique to find adjacent instruction that could be paired with the long-latency instruction to enable that adjacent instruction to make forward progress. However, loop unrolling must also be evaluated on its impact to increased code size and pressure to the branch target buffer.

The performance monitoring event "BACLEARs" can provide a means to evaluate whether loop unrolling is helping or hurting front end performance. Another event "ICACHE_MISSES" can help evaluate if loop unrolling is increasing the instruction footprint.

Branch predictors in Intel Atom processor do not distinguish different branch types. Sometimes mixing different branch types can cause confusion in the branch prediction hardware.

The performance monitoring event "BR_MISSP_TYPE_RETIRED" can provide a means to evaluate branch prediction issues due to branch types.

F.3.2 Optimizing the Execution Core

This section covers several items that can help software use the two-issue-wide execution core to make forward progress with two instructions more frequently.

F.3.2.1 Integer Instruction Selection

In an in-order machine, instruction selection and pairing can have an impact on the machine's ability to discover instruction-level-parallelism for instructions that have data ready to execute. Some examples are:

- **EFLAG:** The consumer instruction of any EFLAG flag bit can not be issued in the same cycle as the producer instruction of the EFLAG register. For example, ADD could modify the carry bit, so it is a producer; JC (or ADC) reads the carry bit and is a consumer.
 - Conditional jumps are able to issue in the following cycle after the consumer.
 - A consumer instruction of other EFLAG bits must wait one cycle to issue after the producer (two cycle delay).

Assembly/Compiler Coding Rule 4. (M impact, H generality) For Intel Atom processors, place a MOV instruction between a flag producer instruction and a flag consumer instruction that would have incurred a two-cycle delay. This will prevent partial flag dependency.

- **Long-latency Integer Instructions:** They will block shorter latency instruction on the same thread from issuing (required by program order). Additionally, they will also block shorter-latency instruction on both threads for one cycle to resolve writeback resource.
- **Common Destination:** Two instructions that produce results to the same destination can not issue in the same cycle.

- **Expensive Instructions:** Some instructions have special requirements and become expensive in consuming hardware resources for an extended period during execution. It may be delayed in execution until it is the oldest in the instruction queue; it may delay the issuing of other younger instructions. Examples of these include FDIV, instructions requiring execution units from both ports, etc.

F.3.2.2 Address Generation

The hardware optimizes the general case of instruction ready to execute must have data ready, and address generation precedes data being ready. If address generation encounters a dependency that needs data from another instruction, this dependency in address generation will incur a delay of 3 cycles.

The address generation unit (AGU) may be used directly in three situations that affect execution throughput of the two-wide machine. The situations are:

- **Implicit ESP updates:** When the ESP register is not used as the destination of an instruction (explicit ESP updates), an implicit ESP update will occur with instructions like PUSH, POP, CALL, RETURN. Mixing explicit ESP updates and implicit ESP updates will also lead to dependency between address generation and data execution.
- **LEA:** The LEA instruction uses the AGU instead of the ALU. If one of the source register of LEA must come from an execution unit. This dependency will also cause a 3 cycle delay. Thus, LEA should not be used in the technique of adding two values and produce the result in a third register. LEA should be used for address computation.
- **Integer-FP/SIMD transfer:** Instructions that transfer integer data to the FP/SIMD side of the machine also uses AGU. Examples of these instructions include MOVD, PINSRW. If one of the source register of these instructions depends on the result of an execution unit, this dependency will also cause a delay of 3 cycles.

Example F-2. Alternative to Prevent AGU and Execution Unit Dependency

```

a) Three cycle delay when using LEA in ternary operations
   mov eax, 0x01
   lea eax, 0x8000[eax+ebp]; values in eax comes from execution of previous instruction
   ; 3 cycle delay due to lea and execution dependency

b) Dependency handled in execution, avoiding AGU and execution dependency
   mov eax, 0x01
   add eax, 0x8000
   add eax, ebp

```

Assembly/Compiler Coding Rule 5. (MH impact, H generality) For Intel Atom processors, LEA should be used for address manipulation; but software should avoid the following situations which creates dependencies from ALU to AGU: an ALU instruction (instead of LEA) for address manipulation or ESP updates; a LEA for ternary addition or non-destructive writes which do not feed address generation. Alternatively, hoist producer instruction more than 3 cycles above the consumer instruction that uses the AGU.

F.3.2.3 Integer Multiply

Integer multiply instruction takes several cycles to execute. They are pipelined such that an integer multiply instruction and another long-latency instruction can make forward progress in the execution phase. However, integer multiply instructions will block other single-cycle integer instructions from issuing due to requirement of program order.

Assembly/Compiler Coding Rule 6. (M impact, M generality) For Intel Atom processors, sequence an independent FP or integer multiply after an integer multiply instruction to take advantage of pipelined IMUL execution.

Example F-3. Pipeling Instruction Execution in Integer Computation

```

a) Multi-cycle Imul instruction can block 1-cycle integer instruction
   imul eax, eax
   add ecx, ecx ; 1 cycle int instruction blocked by imul for 4 cycles
   imul ebx, ebx ; instruction blocked by in-order issue

b) Back-to-back issue of independent imul are pipelined
   imul eax, eax
   imul ebx, ebx ; 2nd imul can issue 1 cycle later
   add ecx, ecx ; 1 cycle int instruction blocked by imul

```

F.3.2.4 Integer Shift Instructions

Integer shift instructions that encodes shift count in the immediate byte have one-cycle latency. In contrast, shift instructions using shift count in the ECX register may need to wait for the register count are updated. Thus shift instruction using register count has 3-cycle latency.

Assembly/Compiler Coding Rule 7. (M impact, M generality) For Intel Atom processors, hoist the producer instruction for the implicit register count of an integer shift instruction before the shift instruction by at least two cycles.

F.3.2.5 Partial Register Access

Although partial register access does not cause additional delay, the in-order hardware tracks dependency on the full register. Thus 8-bit registers like AL and AH are not treated as independent registers. Additionally some instructions like LEA, vanilla loads, and pop are slower when the input is smaller than 4 bytes.

Assembly/Compiler Coding Rule 8. (M impact, MH generality) For Intel Atom processors, LEA, simple loads and POP are slower if the input is smaller than 4 bytes.

F.3.2.6 FP/SIMD Instruction Selection

Table F-1 summarizes the characteristics of various execution units in Intel Atom microarchitecture that are likely used most frequently by software.

Table F-1. Instruction Latency/Throughput Summary of Intel Atom® Microarchitecture

Instruction Category	Latency (cycles)	Throughput	# of Execution Unit
SIMD Integer ALU			
128-bit ALU/logical/move	1	1	2
64-bit ALU/logical/move	1	1	2
SIMD Integer Shift			
128-bit	1	1	1
64-bit	1	1	1

Table F-1. Instruction Latency/Throughput Summary of Intel Atom® Microarchitecture (Contd.)

Instruction Category	Latency (cycles)	Throughput	# of Execution Unit
SIMD Shuffle			
128-bit	1	1	1
64-bit	1	1	1
SIMD Integer Multiply			
128-bit	5	2	1
64-bit	4	1	1
FP Adder			
X87 Ops (FADD)	5	1	1
Scalar SIMD (addsd, addss)	5	1	1
Packed single (addps)	5	1	1
Packed double (addpd)	6	5	1
FP Multiplier			
X87 Ops (FMUL)	5	2	1
Scalar single (mulss)	4	1	1
Scalar double (mulsd)	5	2	1
Packed single (mulps)	5	2	1
Packed double (mulpd)	9	9	1
IMUL			
IMUL r32, r/m32	5	1	1
IMUL r12, r/m16	6	1	1

SIMD/FP instruction selection generally should favor shorter latency first, then favor faster throughput alternatives whenever possible. Note that packed double-precision instructions are not pipelined, using two scalar double-precision instead can achieve higher performance in the execution cluster.

Assembly/Compiler Coding Rule 9. (MH impact, H generality) For Intel Atom processors, prefer SIMD instructions operating on XMM register over X87 instructions using FP stack. Use Packed single-precision instructions where possible. Replace packed double-precision instruction with scalar double-precision instructions.

Assembly/Compiler Coding Rule 10. (M impact, ML generality) For Intel Atom processors, library software performing sophisticated math operations like transcendental functions should use SIMD instructions operating on XMM register instead of native X87 instructions.

Assembly/Compiler Coding Rule 11. (M impact, M generality) For Intel Atom processors, enable DAZ and FTZ whenever possible.

Several performance monitoring events may be useful for SIMD/FP instruction selection tuning: "SIMD_INST_RETIRED.{PACKED_SINGLE, SCALAR_SINGLE, PACKED_DOUBLE, SCALAR_DOUBLE}" can be used to determine the instruction selection in the program. "FP_ASSIST" and "SIR" can be used to see if floating exceptions (or false alarms) are impacting program performance.

The latency and throughput of divide instructions vary with input values and data size. Intel Atom microarchitecture implements a radix-2 based divider unit. So, divide/sqrt latency will be significantly longer than other FP operations. The issue throughput rate of divide/sqrt will be correspondingly lower.

The divide unit is shared between two logical processors, so software should consider all alternatives to using the divide instructions.

Assembly/Compiler Coding Rule 12. (H impact, L generality) For Intel Atom processors, use divide instruction only when it is absolutely necessary, and pay attention to use the smallest data size operand.

The performance monitoring events "DIV" and "CYCLES_DIV_BUSY" can be used to see if the divides are a bottleneck in the program.

FP operations generally have longer latency than integer instructions. Writeback of results from FP operation generally occur later in the pipe stages than integer pipeline. Consequently, if an instruction has dependency on the result of some FP operation, there will be a two-cycle delay. Examples of these type of instructions are FP-to-integer conversions CVTxx2xx, MOVD from XMM to general purpose registers.

In situations where software needs to do computation with consecutive groups 4 single-precision data elements, PALIGNR+MOVAPS is preferred over MOVUPS. Loading 4 data elements with unconstrained array index k , such as MOVUPS xmm1, _pArray[k], where the memory address _pArray is aligned on 16-byte boundary, will periodically causing cache line split, incurring a 14-cycle delay.

The optimal approach is for each k that is not a multiple of 4, round down k to multiples of 4 with $j = 4*(k/4)$, do a MOVAPS MOVAPS xmm1, _pArray[j] and MOVAPS xmm1, _pArray[j+4], and use PALIGNR to splice together the four data elements needed for computation.

Assembly/Compiler Coding Rule 13. (MH impact, M generality) For Intel Atom processors, prefer a sequence MOVAPS+PALIGN over MOVUPS. Similarly, MOVDQA+PALIGNR is preferred over MOVDQU.

F.3.3 Optimizing Memory Access

This section covers several items that can help software optimize the performance of the memory subsystem.

Memory access to system memory or cache access that encounter certain hazards can cause the memory access to become an expensive operation, blocking short-latency instructions to issue even when they have data ready to execute.

The performance monitoring events "REISSUE" can be used to assess the impact of re-issued memory instructions in the program.

F.3.3.1 Store Forwarding

In a few limited situations, Intel Atom microarchitecture can forward data from a preceding store operation to a subsequent load instruction. The situations are:

- Store-forwarding is supported only in the integer pipeline, and does not apply to FP nor SIMD data. Furthermore, the following conditions must be met:
 - a. The store and load operations must be of the same size and to the same address.
 - b. Data size larger than 8 bytes do not forward from a store operation.
- When data forwarding proceeds, data is forwarded base on the least significant 12 bits of the address. So software must avoid the address aliasing situation of storing to an address and then loading from another address that aliases in the lowest 12-bits with the store address.

F.3.3.2 First-level Data Cache

Intel Atom microarchitecture handles each 64-byte cache line of the first-level data cache in 16 4-byte chunks. This implementation characteristic has a performance impact to data alignment and some data access patterns.

Assembly/Compiler Coding Rule 14. (MH impact, H generality) For Intel Atom processors, ensure data are aligned in memory to its natural size. For example, 4-byte data should be aligned to 4-byte boundary, etc. Additionally, smaller access (less than 4 bytes) within a chunk may experience delay if they touch different bytes.

F.3.3.3 Segment Base

In Intel Atom microarchitecture, the address generation unit assumes that the segment base will be 0 by default. Non-zero segment base will cause load and store operations to experience a delay.

- If the segment base isn't aligned to a cache line boundary, the max throughput of memory operations is reduced to one every 9 cycles.

If the segment base is non-zero but cache line aligned the penalty varies by segment base.

- DS will have a max throughput of one every two cycles.
- FS, and GS will have a max throughput of one every two cycles. However, FS and GS are anticipated to be used only with non-zero bases and therefore have a max throughput of one every two cycles even if the segment base is zero.
- ES:
 - If used as the implicit segment base for the destination of string operation, will have a max throughput of one every two cycles for non-zero but cacheline aligned bases.
 - Otherwise, only do one operation every nine cycles.
- CS and SS will always have a max throughput of one every nine cycles if its segment base is non-zero but cache line aligned.

Assembly/Compiler Coding Rule 15. (H impact, ML generality) For Intel Atom processors, use segments with base set to 0 whenever possible; avoid non-zero segment base address that is not aligned to cache line boundary at all cost.

Assembly/Compiler Coding Rule 16. (H impact, L generality) For Intel Atom processors, when using non-zero segment bases, Use DS, FS, GS; string operation should use implicit ES.

Assembly/Compiler Coding Rule 17. (M impact, ML generality) For Intel Atom processors, favor using ES, DS, SS over FS, GS with zero segment base.

F.3.3.4 String Moves

Using MOVSB/STOSB instruction and REP prefix on Intel Atom processor should recognize the following items:

- For small count values, using REP prefix is less efficient than not using REP prefix. This is because the hardware does not have small REP count optimization.
- For small count values, using REP prefix is less efficient than not using REP prefix. This is because the hardware does not have small REP count optimization.
- For large count values, using REP prefix will be less efficient than using 16-byte SIMD instructions.
- Incrementing address in loop iterations should favor LEA instruction over explicit ADD instruction.
- If data footprint is such that memory operation is accessing L2, use of software prefetch to bring data to L1 can avoid memory operation from being re-issued.
- If string/memory operation is accessing system memory, using non-temporal hints of streaming store instructions can avoid cache pollution.

Example F-4. Memory Copy of 64-byte

```

T1:  prefetcht0 [eax+edx+0x80] ; prefetch ahead by two iterations
      movdqa  xmm0, [eax+ edx] ; load data from source (in L1 by prefetch)
      movdqa  xmm1, [eax+ edx+0x10]
      movdqa  xmm2, [eax+ edx+0x20]
      movdqa  xmm3, [eax+ edx+0x30]
      movdqa  [ebx+ edx], xmm0; store data to destination
      movdqa  [ebx+ edx+0x10], xmm1
      movdqa  [ebx+ edx+0x30], xmm2
      movdqa  [ebx+ edx+0x30], xmm3
      lea    edx, 0x40 ; use LEA to adjust offset address for next iteration
      dec    ecx
      jnz    T1

```

F.3.3.5 Parameter Passing

Due to the limited situations of load-to-store forwarding support in Intel Atom microarchitecture, parameter passing via the stack places restrictions on optimal usage by the callee function. For example, “bool” and “char” data usually are pushed onto the stack as 32-bit data, a callee function that reads “bool” or “char” data off the stack will face store-forwarding delay and causing the memory operation to be re-issued.

Compiler should recognize this limitation and generate prolog for callee function to read 32-bit data instead of smaller sizes.

Assembly/Compiler Coding Rule 18. (MH impact, M generality) For Intel Atom processors, “bool” and “char” value should be passed onto and read off the stack as 32-bit data.

F.3.3.6 Function Calls

In Intel Atom microarchitecture, using PUSH/POP instructions to manage stack space and address adjustment between function calls/returns will be more optimal than using ENTER/LEAVE alternatives. This is because PUSH/POP will not need MSROM flows and stack pointer address update is done at AGU.

When a callee function need to return to the caller, the callee could issue POP instruction to restore data and restore the stack pointer from the EBP.

Assembly/Compiler Coding Rule 19. (MH impact, M generality) For Intel Atom processors, favor register form of PUSH/POP and avoid using LEAVE; Use LEA to adjust ESP instead of ADD/SUB.

F.3.3.7 Optimization of Multiply/Add Dependent Chains

Computations of dependent multiply and add operations can illustrate the usage of several coding techniques to optimize for the front end and in-order execution pipeline of the Intel Atom microarchitecture.

Example F-5a shows a code sequence that may be used on out-of-order microarchitectures. This sequence is far from optimal on Intel Atom microarchitecture. The full latency of multiply and add operations are exposed and it is not very successful at taking advantage of the two-issue pipeline.

Example F-5b shows an improved code sequence that takes advantage of the two-issue in-order pipeline of Intel Atom microarchitecture. Because the dependency between multiply and add operations are present, the exposure of latency are only partially covered.

Example F-5. Examples of Dependent Multiply and Add Computation

a) Instruction sequence that encounters stalls

; accumulator xmm2 initialized

```
Top:  movaps xmm0, [esi] ; vector stored in 16-byte aligned memory
      movaps xmm1, [edi] ; vector stored in 16-byte aligned memory
      mulps xmm0, xmm1
      addps xmm2, xmm0 ; dependency and branch exposes latency of mul and add
      add esi, 16 ;
      add edi, 16
      sub ecx, 1
      jnz top
```

b) Improved instruction sequence to increase execution throughput

; accumulator xmm4 initialized

```
Top:  movaps xmm0, [esi] ; vector stored in 16-byte aligned memory
      lea esi, [esi+16] ; can schedule in parallel with load
      mulps xmm0, [edi] ;
      lea edi, [edi+16] ; can schedule in parallel with multiply
      addps xmm4, xmm0 ; latency exposures partially covered by independent instructions
      dec ecx ;
      jnz top
```

c) Improving instruction sequence further by unrolling and interleaving

; accumulator xmm0, xmm1, xmm2, xmm3 initialized

```
Top:  movaps xmm0, [esi] ; vector stored in 16-byte aligned memory
      lea esi, [esi+16] ; can schedule in parallel with load
      mulps xmm0, [edi] ;
      lea edi, [edi+16] ; can schedule in parallel with multiply
      addps xmm5, xmm1 ; dependent multiply hoisted by unrolling and interleaving
      movaps xmm1, [esi] ; vector stored in 16-byte aligned memory
      lea esi, [esi+16] ; can schedule in parallel with load
      mulps xmm1, [edi] ;
      lea edi, [edi+16] ; can schedule in parallel with multiply
      addps xmm6, xmm2 ; dependent multiply hoisted by unrolling and interleaving
                                     (continue)

      movaps xmm2, [esi] ; vector stored in 16-byte aligned memory
      lea esi, [esi+16] ; can schedule in parallel with load
      mulps xmm2, [edi] ;
      lea edi, [edi+16] ; can schedule in parallel with multiply
      addps xmm7, xmm3 ; dependent multiply hoisted by unrolling and interleaving
      movaps xmm3, [esi] ; vector stored in 16-byte aligned memory
      lea esi, [esi+16] ; can schedule in parallel with load
      mulps xmm3, [edi] ;
      lea edi, [edi+16] ; can schedule in parallel with multiply
      addps xmm4, xmm0 ; dependent multiply hoisted by unrolling and interleaving
      sub ecx, 4;
      jnz top
      ; sum up accumulators xmm0, xmm1, xmm2, xmm3 to reduce dependency inside the loop
```

Example F-5c illustrates a technique that increases instruction-level parallelism and further reduces latency exposures of the multiply and add operations. By unrolling four times, each ADDPS instruction can be hoisted far from its dependent producer instruction MULPS. Using an interleaving technique, non-dependent ADDPS and MULPS can be placed in close proximity. Because the hardware that executes MULPS and ADDPS is pipelined, the associated latency can be covered much more effectively by this technique relative to Example F-5b.

F.3.3.8 Position Independent Code

Position independent code often needs to obtain the value of the instruction pointer. Example F-5a show one technique to put the value of IP into the ECX register by issuing a CALL without a matching RET. Example F-5b show an alternative technique to put the value of IP into the ECX register using a matched pair of CALL/RET.

Example F-6. Instruction Pointer Query Techniques

<p>a) Using call without return to obtain IP</p> <pre> call _label; return address pushed is the IP of next instruction _label: pop ECX; IP of this instruction is now put into ECX </pre>
<p>b) Using matched call/ret pair</p> <pre> call _lblcx; ... ; ECX now contains IP of this instruction ... _labelcx mov ecx, [esp]; ret </pre>

F.4 INSTRUCTION LATENCY

This section lists the port-binding and latency information of Intel Atom microarchitecture. The port-binding information for each instruction may show one of 3 situations:

- 'Single digit' - the specific port that must be issued.
- (0, 1) - either port 0 or port 1.
- 'B' - both ports are required.

In the "Instruction" column:

- If different operand syntax of the same instruction have the same port-binding and latency, operand syntax is omitted.
- When different operand syntax may produce different latency or port binding, the operand syntax is listed; but instruction syntax of different operand sizes may be compacted and abbreviated with a footnote.

Instruction that required decoder assistance from MSROM are marked in the "Comment" column (should be used minimally if more decode-efficient alternatives are available).

Table F-2. Intel Atom® Microarchitecture Instructions Latency Data

Instruction	Ports	Latency	Throughput
DisplayFamily_DisplayModel	06_1CH, 06_26H, 06_27H	06_1CH, 06_26H, 06_27H	06_1CH, 06_26H, 06_27H
ADD/AND/CMP/OR/SUB/XOR/TEST ¹ (E)AX/AL, imm;	(0, 1)	1	0.5
ADD/AND/CMP/OR/SUB/XOR ² mem, lmm8; ADD/AND/CMP/OR/SUB/XOR/TEST ⁴ mem, imm; TEST m8, imm8	0	1	1
ADD/AND/CMP/OR/SUB/XOR/TEST ² mem, reg; ADD/AND/CMP/OR/SUB/XOR ² reg, mem;	0	1	1
ADD/AND/CMP/OR/SUB/XOR ² reg, lmm8; ADD/AND/CMP/OR/SUB/XOR ⁴ reg, imm	(0, 1)	1	0.5
ADDPD/ADDSUBPD/MAXPD/MAXPS/MINPD/MINPS/SUBPD xmm, mem	B	7	6
ADDPD/ADDSUBPD/MAXPD/MAXPS/MINPD/MINPS/SUBPD xmm, xmm	B	6	5
ADDPS/ADDS/ADDSS/ADDSUBPS/SUBPS/SUBSD/SUBSS xmm, mem	B	5	1
ADDPS/ADDS/ADDSS/ADDSUBPS/SUBPS/SUBSD/SUBSS xmm, xmm	1	5	1
ANDNPD/ANDNPS/ANDPD/ANDPS/ORPD/ORPS/XORPD/XORPS xmm, mem	0	1	1
ANDNPD/ANDNPS/ANDPD/ANDPS/ORPD/ORPS/XORPD/XORPS xmm, xmm	(0, 1)	1	1
BSF/BSR r16, m16	B	17	16
BSF/BSR ³ reg, mem	B	16	15
BSF/BSR ⁴ reg, reg	B	16	15
BT m16, imm8; BT ³ mem, imm8	(0, 1)	2; 1	1
BT m16, r16; BT ³ mem, reg	B	10, 9	8
BT ⁴ reg, imm8; BT ⁴ reg, reg	1	1	1
BTC m16, imm8; BTC ³ mem, imm8	B	3; 2	2
BTC/BTR/BTS m16; r16	B	12	11
BTC/BTR/BTS ³ mem, reg	B	11	10
BTC/BTR/BTS ⁴ reg, imm8; BTC/BTR/BTS ⁴ reg, reg	1	1	1
CALL mem	(0, 1)	2	2
CALL reg; CALL rel16; CALL rel32	B	1	1
CMOV ⁴ reg, mem; MOV ¹ (E)AX/AL, MOFFS; MOV ² mem, imm	0	1	1
CMOV ⁴ reg, reg; MOV ² reg, imm; MOV ² reg, reg; ; SETcc r8	(0, 1)	1	0.5
CMPPD/CMPPS xmm, mem, imm; CVTTPS2DQ xmm, mem	B	7	6
CMPPD/CMPPS xmm, xmm, imm; CVTTPS2DQ xmm, xmm	B	6	5
CMPSD/CMPS xmm, mem, imm	B	5	1
CMPSD/CMPS xmm, xmm, imm	1	5	1
(U)COMISD/(U)COMISS xmm, mem;	B	10	9
(U)COMISD/(U)COMISS xmm, xmm;	B	9	8
CVTDQ2PD/CVTPD2DQ/CVTPD2PS xmm, mem	B	8	7
CVTDQ2PD/CVTPD2DQ/CVTPD2PS xmm, xmm	B	7	6
CVTDQ2PS/CVTSD2SS/CVTSI2SS/CVTSS2SD xmm, mem	B	7	6

Table F-2. Intel Atom® Microarchitecture Instructions Latency Data (Contd.)

Instruction	Ports	Latency	Throughput
DisplayFamily_DisplayModel	06_1CH, 06_26H, 06_27H	06_1CH, 06_26H, 06_27H	06_1CH, 06_26H, 06_27H
CVTDQ2PS/CVTSD2SS/CVTSS2SD xmm, xmm	B	6	5
CVT(T)PD2PI mm, mem; CVTPI2PD xmm, mem	B	8	7
CVT(T)PD2PI mm, xmm; CVTPI2PD xmm, mm	B	7	6
CVTPI2PS/CVTSI2SD xmm, mem;	B	5	4
CVTPI2PS xmm, mm;	1	5	1
CVTPS2DQ xmm, mem;	B	7	6
CVTPS2DQ xmm, xmm;	B	6	5
CVT(T)PS2PI mm, mem;	B	5	5
CVT(T)PS2PI mm, xmm;	1	5	1
CVT(T)SD2SI ³ reg, mem; CVT(T)SS2SI r32, mem	B	9	8
CVT(T)SD2SI ³ reg, xmm; CVT(T)SS2SI r32, xmm	B	8	7
CVTSI2SD xmm, r32; CVTSI2SS xmm, r32	B	7; 6	5
CVTSI2SD xmm, r64; CVTSI2SS xmm, r64	B	6; 7	5
CVT(T)SS2SI r64, mem; RCPPS xmm, mem	B	10	9
CVT(T)SS2SI r64, xmm; RCPPS xmm, xmm	B	9	8
CVTTPD2DQ xmm, mem	B	8	7
CVTTPD2DQ xmm, xmm	B	7	6
DEC/INC ² mem; MASKMOVQ; MOVAPD/MOVAPS mem, xmm	0	1	1
DEC/INC ² reg; FLD ST; FST/FSTP ST; MOVDQ2Q mm, xmm	(0, 1)	1	0.5
DIVPD; DIVPS	B	125; 70	124; 69
DIVSD; DIVSS	B	62; 34	61; 33
EMMS; LDMXCSR	B	5	4
FABS/FCHS/FXCH; MOVQ2DQ xmm, mm; MOVSX/MOVZX r16, r16	(0, 1)	1	0.5
FADD/FSUB/FSUBR ³ mem	B	5	4
FADD/FADDP/FSUB/FSUBP/FSUBR/FSUBRP ST;	1	5	1
FCMOV	B	6	5
FCOM/FCOMP ³ mem	B	1	1
FCOM/FCOMP/FCOMPP/FUCOM/FUCOMP ST; FTST	1	1	1
FCOMI/FCOMIP/FUCOMI/FUCOMIP ST	B	9	8
FDIV/FSQRT ³ mem; FDIV/FSQRT ST	0	25-65	24-64
FIADD/FIMUL ⁵ mem	B	11	10
FICOM/FICOMP mem	B	7	6
FILD ⁴ mem	B	5	4
FLD ³ mem; FXAM; MOVAPD/MOVAPS/MOVD xmm, mem	0	1	1
FLDCW	B	5	4
FMUL/FMULP ST; FMUL ³ mem	0	5	1

Table F-2. Intel Atom® Microarchitecture Instructions Latency Data (Contd.)

Instruction	Ports	Latency	Throughput
DisplayFamily_DisplayModel	06_1CH, 06_26H, 06_27H	06_1CH, 06_26H, 06_27H	06_1CH, 06_26H, 06_27H
FNSTSW AX; FNSTSW m16	B	10; 14	9; 13
FST/FSTP ³ mem	B	2	1
HADDPD/HADDPs/HSUBPD/HSUBPS xmm, mem	B	9	8
HADDPD/HADDPs/HSUBPD/HSUBPS xmm, xmm	B	8	7
IDIV r/m8; IDIV r/m16; IDIV r/m32; IDIV r/m64;	B	33;42;57;1 97	32;41;56;19 6
IMUL/MUL ⁶ EAX/AL, mem; IMUL/MUL AX, m16	B	7; 8	6; 7
IMUL/MUL ⁷ AX/AL, reg; IMUL/MUL EAX, r32	B	7; 6	6; 5
IMUL m16, imm8/imm16; IMUL r16, m16	B	7;	6
IMUL r/m32, imm8/imm32; IMUL r32, r/m32	0	5	1
IMUL r/m64, imm8/imm32;	B	14	13
IMUL r16, r16; IMUL r16, imm8/imm16	B	6	5
IMUL r64, r/m64; IMUL/MUL RAX, r/m64	B	11; 12	10; 11
JCC ¹ ; JMP ⁴ reg; JMP ¹	1	1	1
JCXZ; JECXZ; JRCXZ	B	4	1
JMP mem ⁴ ;	B	2	1
LDDQU; MOVDQU/MOVUPD/MOVUPS xmm, mem;	B	3	2
LEA r16, mem; MASKMOVDQU; SETcc m8	(0, 1)	2	1
LEA, reg, mem	1	1	1
LEAVE;	B	2;	2
MAXSD/MAXSS/MINSD/MINSS xmm, mem	B	5	1
MAXSD/MAXSS/MINSD/MINSS xmm, xmm	1	5	1
MOV ² MOFFS, (E)AX/AL; MOV ² reg, mem; MOV ² mem, reg	0	1	1
MOVD mem ³ , mm; MOVD xmm, reg ³ ; MOVD mm, mem ³	0	1	1
MOVD reg ³ , mm; MOVD reg ³ , xmm; PMOVMASK reg ³ , mm	0	3	1
MOVDQA/MOVQ xmm, mem; MOVDQA/MOVD mem, xmm;	0	1	1
MOVDQA/MOVDQU/MOVUPD xmm, xmm; MOVQ mm, mm	(0, 1)	1	0.5
MOVDQU/MOVUPD/MOVUPS mem, xmm;	B	2	2
MOVHLPs; MOVLHPS; MOVHPD/MOVHPS/MOVLPD/MOVLPS	0	1	1
MOVMSKPD/MOVSKPS/PMOVMASKB reg ³ , xmm	0	3	1
MOVNTI ³ mem, reg; MOVNTPD/MOVNTPS; MOVNTQ	0	1	1
MOVQ mem, mm; MOVQ mm, mem; MOVDDUP	0	1	1
MOVSD/MOVSS xmm, xmm; MOVSD ⁵ reg, reg	(0, 1)	1	0.5
MOVSD/MOVSS xmm, mem; PALIGNR	0	1	1
MOVSD/MOVSS mem, xmm; PINSRW	0	1	1
MOVSHDUP/MOVSXDUP xmm, mem	0	1	1

Table F-2. Intel Atom® Microarchitecture Instructions Latency Data (Contd.)

Instruction	Ports	Latency	Throughput
DisplayFamily_DisplayModel	06_1CH, 06_26H, 06_27H	06_1CH, 06_26H, 06_27H	06_1CH, 06_26H, 06_27H
MOVSHDUP/MOVSLDUP/MOVUPS xmm, xmm	(0, 1)	1	0.5
MOVZX/MOVBZX r16, m8; MOVZX/MOVBZX r16, r8	0	3; 2	1
MOVZX/MOVBZX reg ³ , r/m8; MOVZX/MOVBZX reg ³ , r/m16	0	1	1
MOVSD ⁵ reg, mem; MOVSD r64, r/m32	0	1	1
MULPS/MULSD xmm, mem; MULSS xmm, mem;	0	5; 4	2
MULPS/MULSD xmm, xmm; MULSS xmm, xmm	0	5; 4	2
MULPD	B	5; 4	2
NEG/NOT ² mem; PREFETCHNTA; PREFETCHTx	0	10	9
NEG/NOT ² reg; NOP	(0, 1)	1	0.5
PABSB/D/W mm, mem; PABSB/D/W xmm, mem	0	1	1
PABSB/D/W mm, mm; PABSB/D/W xmm, xmm	(0, 1)	1	0.5
PACKSSDW/WB mm, mem; PACKSSDW/WB xmm, mem	0	1	1
PACKSSDW/WB mm, mm; PACKSSDW/WB xmm, xmm	0	1	1
PACKUSWB mm, mem; PACKUSWB xmm, mem	0	1	1
PACKUSWB mm, mm; PACKUSWB xmm, xmm	0	1	1
PADDB/D/W/Q mm, mem; PADDB/D/W/Q xmm, mem	0	1	1
PADDB/D/W/Q mm, mm; PADDB/D/W/Q xmm, xmm	(0, 1)	1	0.5
PADDSB/W mm, mem; PADDSB/W xmm, mem	0	1	1
PADDSB/W mm, mm; PADDSB/W xmm, xmm	(0, 1)	1	0.5
PADDUSB/W mm, mem; PADDUSB/W xmm, mem	0	1	1
PADDUSB/W mm, mm; PADDUSB/W xmm, xmm	(0, 1)	1	0.5
PAND/PANDN/POR/PXOR mm, mem; PAND/PANDN/POR/PXOR xmm, mem	0	1	1
PAND/PANDN/POR/PXOR mm, mm; PAND/PANDN/POR/PXOR xmm, xmm	(0, 1)	1	0.5
PAVGB/W mm, mem; PAVGB/W xmm, mem	0	1	1
PAVGB/W mm, mm; PAVGB/W xmm, xmm	(0, 1)	1	0.5
PCMPEQB/D/W mm, mem; PCMPEQB/D/W xmm, mem	0	1	1
PCMPEQB/D/W mm, mm; PCMPEQB/D/W xmm, xmm	(0, 1)	1	0.5
PCMPGTB/D/W mm, mem; PCMPGTB/D/W xmm, mem	0	1	1
PCMPGTB/D/W mm, mm; PCMPGTB/D/W xmm, xmm	(0, 1)	1	0.5
PEXTRW;	B	4	1
PHADDD/PHSUBD mm, mem; PHADDD/PHSUBD xmm, mem	B	4	3
PHADDD/PHSUBD mm, mm; PHADDD/PHSUBD xmm, xmm	B	3	2
PHADDW/PHADDSW mm, mem; PHADDW/PHADDSW xmm, mem	B	6; 8	5; 7
PHADDW/PHADDSW mm, mm; PHADDW/PHADDSW xmm, xmm	B	5; 7	M
PHSUBW/PHSUBSW mm, mem; PHSUBW/PHSUBSW xmm, mem	B	6; 8	M
PHSUBW/PHSUBSW mm, mm; PHSUBW/PHSUBSW xmm, xmm	B	5; 7	M

Table F-2. Intel Atom® Microarchitecture Instructions Latency Data (Contd.)

Instruction	Ports	Latency	Throughput
DisplayFamily_DisplayModel	06_1CH, 06_26H, 06_27H	06_1CH, 06_26H, 06_27H	06_1CH, 06_26H, 06_27H
PMADDUBSW/PMADDWD/PMULHRSW/PSADBw mm, mm; PMADDUBSW/PMADDWD/PMULHRSW/PSADBw mm, mem	0	4	1
PMADDUBSW/PMADDWD/PMULHRSW/PSADBw xmm, xmm; PMADDUBSW/PMADDWD/PMULHRSW/PSADBw xmm, mem	0	5	1
PMAxSw/UB mm, mem; PMAxSw/UB xmm, mem	0	1	1
PMAxSw/UB mm, mm; PMAxSw/UB xmm, xmm	(0, 1)	1	0.5
PMINSw/UB mm, mem; PMINSw/UB xmm, mem	0	1	1
PMINSw/UB mm, mm; PMINSw/UB xmm, xmm	(0, 1)	1	0.5
PMULHUW/PMULHW/PMULLW/PMULUDQ mm, mm; PMULHUW/PMULHW/PMULLW/PMULUDQ mm, mem	0	4	1
PMULHUW/PMULHW/PMULLW/PMULUDQ xmm, xmm; PMULHUW/PMULHW/PMULLW/PMULUDQ xmm, mem	0	5	1
POP mem ⁵ ; PSLLD/Q/W mm, mem; PSLLD/Q/W xmm, mem	B	3	2
POP r16; PUSH mem ⁴ ; PSLLD/Q/W mm, mm; PSLLD/Q/W xmm, xmm	B	2	1
POP reg ³ ; PUSH reg ⁴ ; PUSH imm	B	1	1
POPA ; POPAD	B	9	8
PSHUFb mm, mem; PSHUFD; PSHUFHW; PSHUFLW; PSHUFW	0	1	1
PSHUFb mm, mm; PSLLD/Q/W mm, imm; PSLLD/Q/W xmm, imm	0	1	1
PSHUFb xmm, mem	B	5	4
PSHUFb xmm, xmm	B	4	3
PSIGNB/D/W mm, mem; PSIGNB/D/W xmm, mem	0	1	1
PSIGNB/D/W mm, mm; PSIGNB/D/W xmm, xmm	(0, 1)	1	0.5
PSRAD/W mm, imm; PSRAD/W xmm, imm;	0	1	1
PSRLD/Q/W mm, mem; PSRLD/Q/W xmm, mem	B	3	2
PSRLD/Q/W mm, mm; PSRLD/Q/W xmm, xmm	B	2	1
PSRLD/Q/W mm, imm; PSRLD/Q/W xmm, imm;	0	1	1
PSLLDQ/PSRLDQ xmm, imm; SHUFPD/SHUFPS	0	1	1
PSUBB/D/W/Q mm, mem; PSUBB/D/W/Q xmm, mem	0	1	1
PSUBB/D/W/Q mm, mm; PSUBB/D/W/Q xmm, xmm	(0, 1)	1	0.5
PSUBSB/W mm, mem; PSUBSB/W xmm, mem	0	1	1
PSUBSB/W mm, mm; PSUBSB/W xmm, xmm	(0, 1)	1	0.5
PSUBUSB/W mm, mem; PSUBUSB/W xmm, mem	0	1	1
PSUBUSB/W mm, mm; PSUBUSB/W xmm, xmm	(0, 1)	1	0.5
PUNPCKHBW/DQ/WD; PUNPCKLBW/DQ/WD	0	1	1
PUNPCKHQDQ; PUNPCKLQDQ	0	1	1
PUSHA ; PUSHAD	B	8	7
RCL mem ² , 1; RCL reg ² , 1	0	1	1

Table F-2. Intel Atom® Microarchitecture Instructions Latency Data (Contd.)

Instruction	Ports	Latency	Throughput
DisplayFamily_DisplayModel	06_1CH, 06_26H, 06_27H	06_1CH, 06_26H, 06_27H	06_1CH, 06_26H, 06_27H
RCL m8, CL; RCL m16, CL; RCL mem ³ , CL;	B	18;16; 14	17;15;13
RCL m8, imm; RCL m16, imm; RCL mem ³ , imm;	B	18; 17; 14	17;16;13
RCL r8, CL; RCL r16, CL; RCL reg ³ , CL;	B	17; 16; 14	16;15;14
RCL r8, imm; RCL r16, imm; RCL reg ³ , imm;	B	18;16; 14	17;15;13
RCPSS	0	4	1
RCR mem ² , 1; RCR reg ² , 1	B	7; 5	6;4
RCR m8, CL; RCR m16, CL; RCR mem ³ , CL;	B	15; 13; 12	14;12;11
RCR m8, imm; RCR m16, imm; RCR mem ³ , imm;	B	16;;14; 12	15;13;11
RCR r8, CL; RCR r16, CL; RCR reg ³ , CL;	B	14; 13; 12	13;12;11
RCR r8, imm; RCR r16, imm; RCR reg ³ , imm;	B	15, 14, 12	14;13;11
RET imm16	B	1	1
RET (far)	B	79	
ROL; ROR; SAL; SAR; SHL; SHR	0	1	1
SETcc		1	1
SHLD ⁸ mem, reg, imm; SHLD r64, r64, imm; SHLD m64, r64, CL	B	11	10
SHLD m32, r32; SHLD r32, r32	B	4; 2	3; 1
SHLD m16, r16, CL; SHLD r16, r16, imm; SHLD r64, r64, CL	B	10	9
SHLD r16, r16, CL; SHRD m64, r64; SHRD r64, r64, imm	B	9	8
SHRD m32, r32; SHRD r32, r32	B	4; 2	3; 1
SHRD m16, r16; SHRD r16, r16	B	6	5
SHRD r64, r64, CL	B	8	7
STMXCSR	B	15	14
TEST ² reg, reg; TEST ⁴ reg, imm	(0, 1)	1	0.5
UNPCKHPD; UNPCKHPS; UNPCKLPD, UNPCKLPS	0	1	1

Notes on operand size (osize) and address size (asize):

1. osize = 8, 16, 32 or asize = 8, 16, 32
2. osize = 8, 16, 32, 64
3. osize = 32, 64
4. osize = 16, 32, 64 or asize = 16, 32, 64
5. osize = 16, 32
6. osize = 8, 32
7. osize = 8, 16
8. osize = 16, 64

F.5 SILVERMONT MICROARCHITECTURE

The Intel Atom processor E3000 and C2000 Series are based on the Silvermont microarchitecture. The Silvermont microarchitecture spans a wide range of computing devices from tablets, phones, and PCs to microservers. In addition to support for Intel 64 and IA-32 architecture, major enhancements of the Silvermont microarchitecture include:

- Out-of-order execution for integer instructions and de-coupled ordering between non-integer and memory instructions. In contrast, the 45nm and 32nm Intel Atom microarchitecture (see Appendix F) was strictly in-order with limited ability to exploit available instruction-level parallelism.
- Non-blocking memory instructions allowing multiple (8) outstanding misses. In previous generation processors, problems in a single memory instruction (for example, a cache miss) caused all subsequent instructions to stall until the problem was resolved. The new microarchitecture allows up to 8 unique outstanding references.
- Modular system design with two cores sharing an L2 cache connected to a new integrated memory controller using a point-to-point interface instead of the Front Side Bus.
- Instruction set enhancements to include SSE 4.1, SSE 4.2, AESNI and PCLMULQDQ.

The block diagram for the Silvermont microarchitecture is depicted in Figure F-1. While the memory and execute clusters were significantly redesigned for improved single thread performance, the primary focus is still a highly efficient design in a small form factor power envelope. Each pipeline is accompanied with a dedicated scheduling queue called a reservation station. While floating-point and memory instructions schedule from their respective queues in program order, integer execution instructions schedule from their respective queues out of order.

Integer instructions can be scheduled from their queues out of order in contrast to in-order execution in previous generations. Out of order scheduling allows these instructions to tolerate stalls caused by unavailable (re)sources. Memory instructions must generate their addresses (AGEN) in-order and schedule from the scheduling queue in-order but they may complete out-of-order.

Non-integer instructions (including SIMD integer, SIMD floating-point, and x87 floating-point) also schedule from their respective scheduling queue in program order. However, these separate scheduling queues allow their execution to be decoupled from instructions in other scheduling queues.

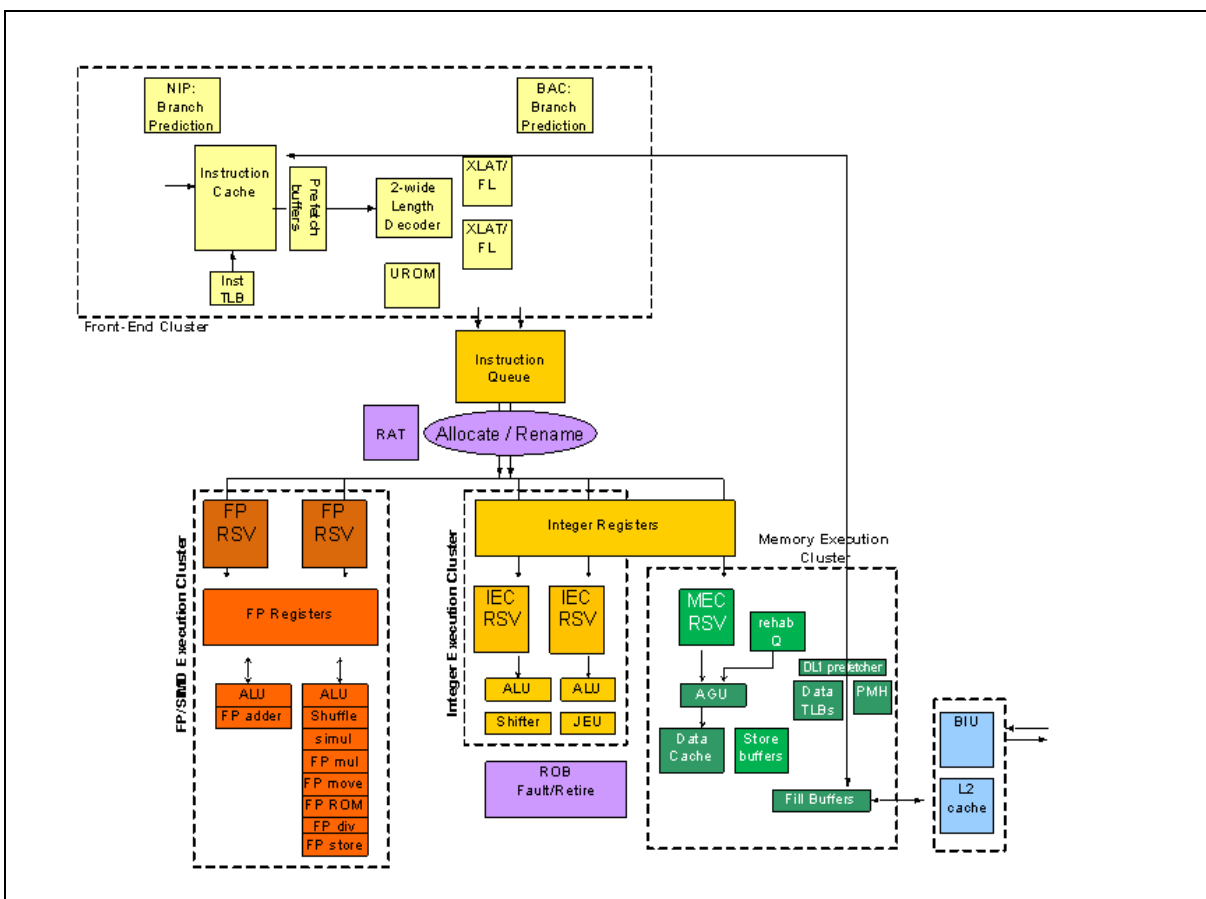

Figure F-2. Silvermont Microarchitecture Pipeline

The design of the microarchitecture takes into account maximizing platform performance of multiple form factors (e.g. phones, tablets, to micro-servers) and minimizing the power and area cost due to out of order scheduling (i.e. maximizing performance/power/cost efficiency). Intel Hyper-Threading Technology is not supported in favor of a multi-core architecture with a shared L2 cache. The rest of this section will cover some of the cluster-level features in more detail.

The front end cluster (FEC), shown in yellow in Figure F-1, features a power optimized 2-wide decode pipeline. FEC is responsible for fetching and decoding instructions from instruction memory. FEC utilizes predecode hints from the icache to avoid costly on-the-fly instruction length determination. The front end contains a Branch Target Buffer (BTB), plus advanced branch predictor hardware.

The front end is connected to the execution units through the Allocation, Renaming and Retirement (ARR) cluster (lavender color in Figure F-1). ARR receives uops from the FEC and is responsible for resource checks. The Register Alias Table (RAT) renames the logical registers to the physical registers. The Reorder Buffer (ROB) puts the operations back into program order and completes (retires) them. It also stops execution at interrupts, exceptions and assists and runs program control over microcode.

Scheduling in the Silvermont microarchitecture is distributed, so after renaming, uops are sent to various clusters (IEC: integer execution cluster; MEC: memory execution cluster; FPC: floating-point cluster) for scheduling (shown as RSV for FP, IEC, and MEC in Figure F-1).

There are 2 sets of reservation stations for FPC and IEC (one for each port) and a single set of reservation stations for MEC. Each reservation station is responsible for receiving up to 2 ops from the ARR cluster in a cycle and selecting one ready op for dispatching to execution as soon as the op becomes ready.

To support the distributed reservation station concept, load-op and load-op-store macro-instructions requiring integer execution must be split into a memory sub-op that is sent to the MEC and resides in the memory reservation station and an integer execution sub-op that is sent to the integer reservation station. The IEC schedulers pick the oldest ready instruction from each of its RSVs while the MEC and the FPC schedulers only look at the oldest instruction in their respective RSVs. Even though the MEC and FPC clusters employ in-order schedulers, a younger instruction from a particular FPC RSV can execute before an older instruction in the other FPC RSV for example (or the IEC or MEC RSVs).

Each execution port has specific functional units available. Table F-3 shows the mapping of functional units to ports for IEC (the orange units in Figure F-1), MEC (the green units in Figure F-1), and the FPC (the red units in Figure F-1). Compared to the previous Intel Atom microarchitecture, the Silvermont microarchitecture adds an integer multiply unit (IMUL) in IEC.

Table F-3. Function Unit Mapping of the Silvermont Microarchitecture

Cluster	Port 0	Port 1
IEC	ALU0, Shift/Rotate Unit, LEA with no index	ALU1, Bit processing unit, Jump unit, IMUL, POPCNT, CRC32, LEA ¹
FPC	SIMD ALU, SIMD shift/Shuffle unit, SIMD FP mul/div/cvt unit, STTNI/AESNI/PCLMULQDQ unit, RCP/RSQRT unit, F2I convert unit	SIMD ALU, SIMD FPadd unit, F2I convert unit
MEC	Load/Store	

NOTES:

1. LEAs with valid index and displacement are split into multiple UOPs and use both ports. LEAs with valid index execute on port 1.

The Memory Execution Cluster (MEC) (shown in green in Figure F-1) can support both 32-bit and 36-bit physical addressing modes. The Silvermont microarchitecture has a 2 level Data TLB hierarchy with support for both large (2MB or 4MB) and small page structures. A small micro TLB (referred to as uTLB) is backed up by a larger 2nd level TLB (referred to as DTLB). A hardware page walker services misses from both the Instruction and Data TLBs.

The MEC also owns the MEC RSV, which is responsible for scheduling of all loads and stores. Load and store instructions go through addresses generation phase in program order to avoid on-the-fly memory ordering later in the pipeline. Therefore, an unknown address will stall younger memory instructions. Memory operations that incur problems (e.g. uTLB misses, unavailable resources, etc.) are put in a separate queue called the RehabQ. This allows younger instructions (that do not incur problems) to continue execution rather than stalling all younger instructions. The problematic instruction is later reissued from the RehabQ when the problem is resolved. Note that load misses are not considered problematic as the Silvermont microarchitecture features a non-blocking data cache that can sustain 8 outstanding misses.

The Bus Cluster (BIU) includes the second-level cache (L2) and is responsible for all communication with components outside the processor core. The L2 cache supports up to 1MB with an optimized latency less than the previous Intel Atom microarchitecture. The Front-Side Bus from earlier Intel Atom processors has been replaced by an intra-die interconnect (IDI) fabric connecting to a newly optimized memory controller. The BIU also houses the L2 data prefetcher.

The new core level multi-processing (or CMP) system configuration features two processor cores making requests to a single BIU, which will handle the multiplexing between cores. This basic CMP module can be replicated to create a quad-core configuration, or one core chopped off to create a single-core configuration.

F.5.1 Integer Pipeline

Load pipeline stages are no longer inlined with the rest of the integer pipeline. As a result, non-load ops can reach execute faster, and the branch misprediction penalty is effectively 3 cycles less compared to earlier Intel Atom processors. Front end pipe stages are the same as earlier Intel Atom processors (3 cycles for fetch, 3 cycles for decode). ARR pipestages perform out-of-order allocation and register renaming, split the uop into parts if necessary, and send them to the distributed reservation stations. RSV stage is where the distributed reservation station performs its scheduling. The execution pipelines are very similar to earlier Intel Atom processors. When all parts of a uop are marked as finished, the ROB handles final completion in-order.

F.5.2 Floating-Point Pipeline

Compared to the INT pipeline, the FP pipeline is longer. The execution stages can vary between one and five depending on the instruction. Like other Intel microarchitectures, the Silvermont microarchitecture needs to limit the number of FP assists (when certain floating-point operations cannot be handled natively by the execution pipeline, and must be performed by microcode) to the bare minimum to achieve high performance. To do this the processor should be run with exceptions masked and the DAZ (denormal as zero) and FTZ (flush to zero) flags set whenever possible.

As mentioned, while each FPC RSV schedules instructions in-order, the RSVs can get out of order with respect to each other.

F.6 GOLDMONT MICROARCHITECTURE

The Goldmont microarchitecture builds on the success of the Silvermont microarchitecture (see Section F.5), and provides the following enhancements:

- An out-of-order execution engine with a 3-wide superscalar pipeline. Specifically:
 - The decoder can decode 3 instructions per cycle.
 - The microcode sequencer can send 3 uops per cycle for allocation into the reservation stations.
 - Retirement supports a peak rate of 3 per cycle.
- Enhancement in branch prediction which de-couples the fetch pipeline from the instruction decoder.
- Larger out-of-order execution window and buffers that enable deeper out-of-order execution across integer, FP/SIMD, and memory instruction types.
- Fully out-of-order memory execution and disambiguation. The Goldmont microarchitecture can execute one load and one store per cycle (compared to one load or one store per cycle in the Silvermont microarchitecture). The memory execution pipeline also includes a second level TLB enhancement with 512 entries for 4KB pages.
- Integer execution cluster in the Goldmont microarchitecture provides three pipelines and can execute up to three simple integer ALU operations per cycle.
- SIMD integer and floating-point instructions execute in a 128-bit wide engine. Throughput and latency of many instructions have improved, including PSHUFB with 1-cycle throughput (versus 5 cycles for Silvermont microarchitecture) and many other SIMD instructions with doubled throughput; see Table F-19 for details.
- Throughput and latency of instructions for accelerating encryption/description (AES) and carry-less multiplication (PCLMULQDQ) have been improved significantly in the Goldmont microarchitecture.
- The Goldmont microarchitecture provides new instructions with hardware accelerated secure hashing algorithm, SHA1 and SHA256.
- The Goldmont microarchitecture also adds support for the RDSEED instruction for random number generation meeting the NIST SP800-90C standard.
- PAUSE instruction latency is optimized to enable better power efficiency.

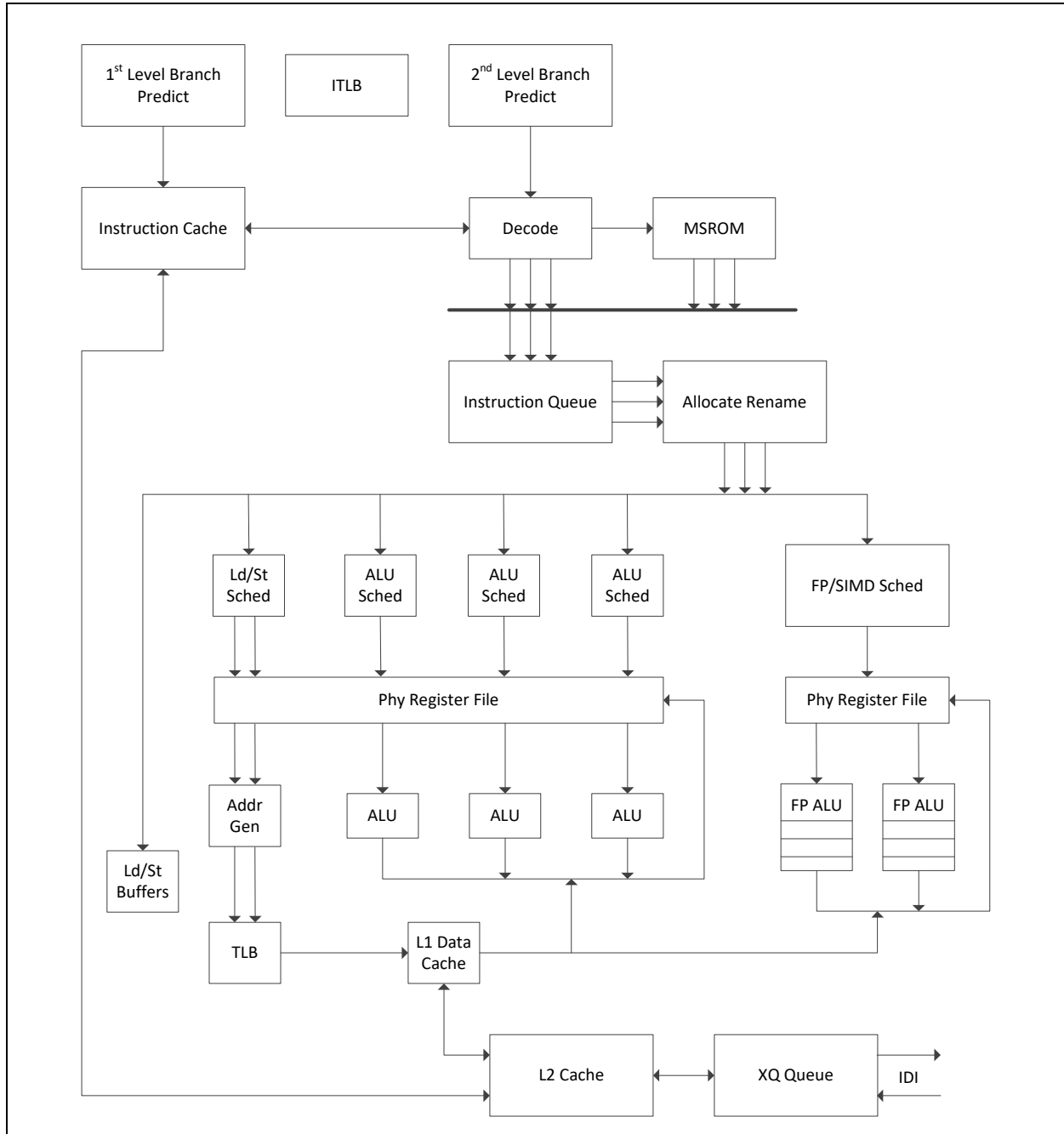

Figure F-3. CPU Core Pipeline Functionality of the Goldmont Microarchitecture

The front end cluster (FEC) of the Goldmont microarchitecture provides a number of enhancements over the FEC of the Silvermont microarchitecture. The enhancements are summarized in Table F-4.

Table F-4. Comparison of Front End Cluster Features

Feature	Goldmont Microarchitecture	Silvermont Microarchitecture
Number of Decoders	3	2
Max Throughput of Decoders	20 Bytes per cycle	16 Bytes per cycle
Fetch and Icache Pipeline	Decoupled	Coupled
ITLB	48 entries, large page support	48 entries
Branch Mispredict Penalty	12 cycles	10 cycles
L2 Predecode Cache	16K	NA

The FEC is connected to the execution units through the Allocation, Renaming and Retirement (ARR) cluster. Scheduling of uops is handled with distributed reservation stations across different clusters (IEC, FPC, MEC). Each cluster has its own reservations for receiving multiple uops from the ARR. Table F-5 compares the out-of-order scheduling characteristics between the Goldmont microarchitecture and Silvermont microarchitecture.

Table F-5. Comparison of Distributed Reservation Stations on Scheduling Uops

Cluster	Goldmont Microarchitecture	Silvermont Microarchitecture
IEC Reservation	3x distributed for each port	2x distributed for each port
	Out-of-order within each IEC RSV and between IEC, across FPC, MEC	Out-of-order within each IEC RSV and between IEC, across FPC, MEC
FPC Reservation	1x unified to ports 0, 1	2x distributed for each port
	Out-of-order within FPC RSV and across IEC, MEC	In order within each FPC RSV; out-of-order between FPC, across IEC, MEC
MEC Reservation	1x unified to ports 0, 1	1x to port 0
	Out-of-order within MEC RSV and across IEC, FPC	In order within each MEC RSV; out-of-order across IEC, FPC

An instruction that references memory and requires integer/FP resources will have the memory uop sent to the MEC cluster and the integer/FP uop sent to the IEC/FPC cluster. Then out-of-order execution can commence according to the heuristic described in Table F-5 and when resources are available. Table F-6 shows the mapping of execution units across each port for respective clusters.

Table F-6. Function Unit Mapping of the Goldmont Microarchitecture

Cluster	Port 0	Port 1	Port 2
IEC	ALU0, Shift/Rotate, LEA with no index, F2I, converts/cmp, store_data	ALU1, Bit processing, JEU, IMUL, IDIV,POPCNT, CRC32, LEA, I2F, store_data	ALU2, LEA ¹ , I2F, flag_merge
FPC	SIMD ALU, SIMD shift/Shuffle, SIMD mul, STTNI/AESNI/PCLMULQDQ/SHA ; FP_mul, Converts, F2I convert	SIMD ALU, SIMD shuffle, FP_add, F2I compare	
MEC	Load_addr	Store_addr	

NOTES:

1. LEAs without index can execute on port 0, 1, or 2. LEA with valid index and displacement are split into multiple UOPs and use both port 1 and 2. LEAs with valid index execute on port 1.

The MEC owns the MEC RSV and is responsible for scheduling all load and stores via ports 0 and 1. Load and store instructions can go through the address generation phase in order or out-of-order. When out-of-order address generation scheduling is available, memory execution pipeline is de-coupled from the address generation pipeline using the load buffers and store buffers.

With out-of-order execution, situations where loads can pass an unknown store may cause memory order issues if the load eventually depended on the unknown store and would require a pipeline flush when the store address is known. The Goldmont microarchitecture keeps track of and minimizes such potentially problematic load executions.

Memory operations that experienced problems (for example, uTLB misses and unavailable resources) go back to load or store buffer for re-execution. This allows younger instructions (that do not incur problems) to continue execution rather than stalling all younger instructions. The problematic instruction is later re-issued (in some cases, re-issued at retirement) from the load/store buffer when the problem is resolved. Note that load misses are considered problematic as the data cache is non-blocking and can sustain multiple outstanding misses using write-combining buffers (WCB).

Table F-7. Comparison of MEC Resources

MEC Resource	Goldmont Microarchitecture	Silvermont Microarchitecture
L1 Data Cache	24KB	24 KB
uTLB	32 entries	32 entries
DTLB (4KB page)	512 entries	128 entries
DTLB (2M/4M page)	32 entries	16 entries
Load-use Latency	3 cycles	3 cycles
Pipeline	1x load + 1x store	1x share by load/store
AGEN	Out-of-order	In order
WCBs	8	8
Addressing	39-bit physical, 48-bit linear	36-bit physical, 48-bit linear

F.7 GOLDMONT PLUS MICROARCHITECTURE

The Goldmont Plus microarchitecture builds on the success of the Goldmont microarchitecture (see Section F.6), and provides the following enhancements:

- Widen previous generation Intel Atom processor back-end pipeline to 4-wide allocation to 4-wide retire, while maintaining 3-wide fetch and decode pipeline.
- Enhanced branch prediction unit.
- 64KB shared second level pre-decode cache (16KB in Goldmont microarchitecture).
- Larger reservation station and ROB entries to support large out-of-order window.
- Wider integer execution unit. New dedicated JEU port with support for faster branch redirection.
- Radix-1024 floating point divider for fast scalar/packed single, double and extended precision floating point divides.
- Improved AES-NI instruction latency and throughput.
- Larger load and store buffers. Improved store-to-load forwarding latency store data from register.
- Shared instruction and data second level TLB. Paging Cache Enhancements (PxE/ePxE caches).
- Modular system design with four cores sharing up to 4MB L2 cache.

- Support for Read Processor ID (RDP) new instruction.

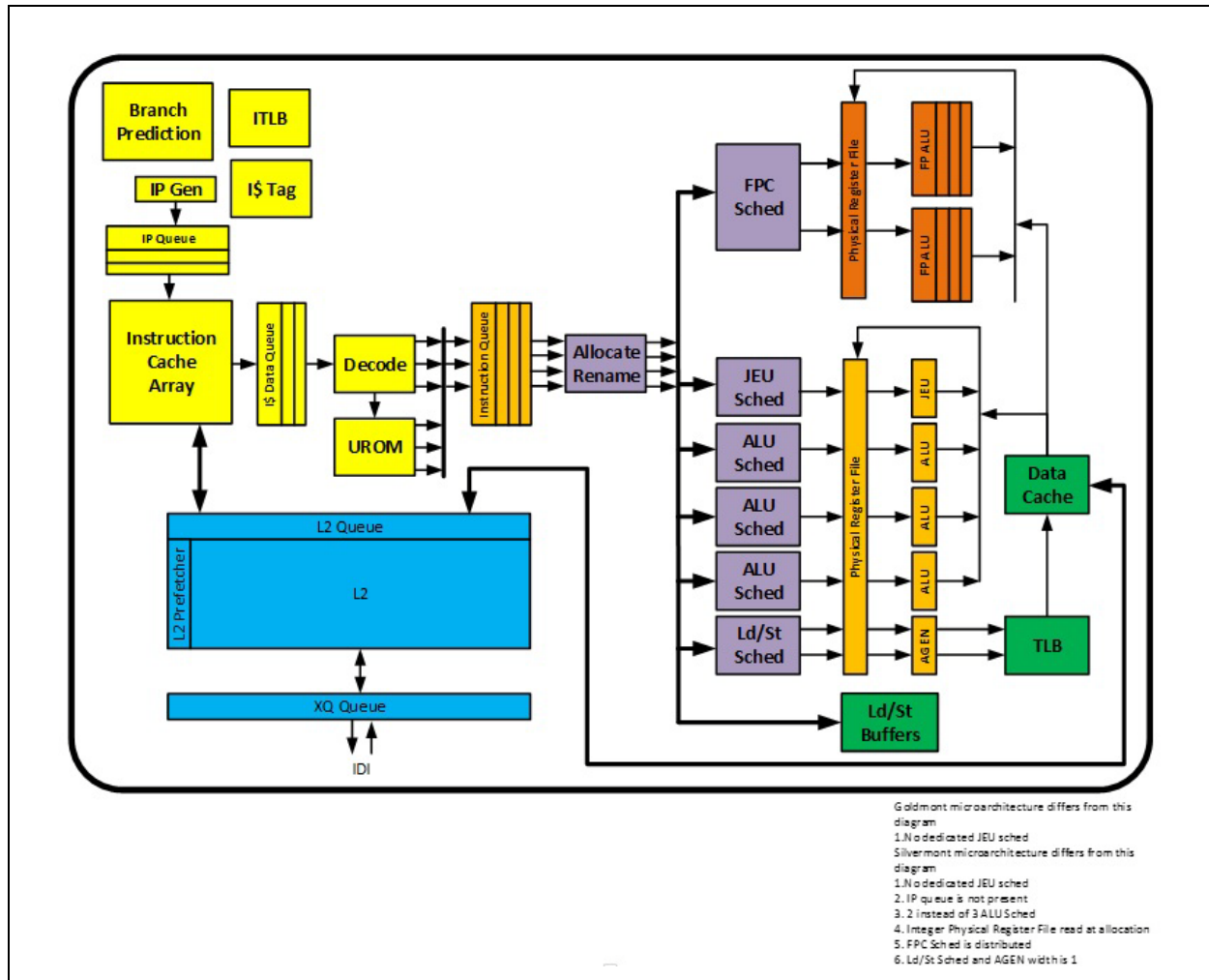

Figure F-4. CPU Core Pipeline Functionality of the Goldmont Plus Microarchitecture

The front end cluster (FEC) of the Goldmont Plus microarchitecture provides a number of enhancements over the FEC of the Goldmont microarchitecture. The enhancements are summarized in Table F-8.

Table F-8. Comparison of Front End Cluster Features

Feature	Goldmont Plus Microarchitecture	Goldmont Microarchitecture
Number of Decoders	3	3
Max. Throughput Decoders	20 Bytes per cycle	20 Bytes per cycle
Fetch and Icache Pipeline	Decoupled	Decoupled
ITLB	48 entries, large page support	48 entries, large page support
2nd Level ITLB	Shared with DTLB	
Branch Mispredict Penalty	13 cycles (12 cycles for certain Jcc)	12 cycles
L2 Predecode Cache	64K	16K

The FEC is connected to the execution units through the Allocation, Renaming and Retirement (ARR) cluster. Scheduling of uops is handled with distributed reservation stations across different clusters (IEC, FPC, MEC). Each cluster has its own reservations for receiving multiple uops from the ARR. Table F-9 compares the out-of-order scheduling characteristics between the Goldmont Plus microarchitecture and Goldmont microarchitecture.

Table F-9. Comparison of Distributed Reservation Stations on Scheduling Uops

Cluster	Goldmont Plus Microarchitecture	Goldmont Microarchitecture
IEC Reservation	4x distributed for each port	3x distributed for each port
	Out-of-order within each IEC RSV and between IEC, across FPC, MEC	Out-of-order within each IEC RSV and between IEC, across FPC, MEC
FPC Reservation	1x unified to ports 0, 1	1x unified to ports 0, 1
	Out-of-order within FPC RSV and across IEC, MEC	Out-of-order within FPC RSV and across IEC, MEC
MEC Reservation	1x unified to ports 0, 1	1x unified to ports 0, 1
	Out-of-order within MEC RSV and across IEC, FPC	Out-of-order within MEC RSV and across IEC, FPC

An instruction that references memory and requires integer/FP resources will have the memory uop sent to the MEC cluster and the integer/FP uop sent to the IEC/FPC cluster. Then out-of-order execution can commence according to the heuristic described in Table F-9 when resources are available. Table F-10 shows the mapping of execution units across each port for respective clusters.

Table F-10. Function Unit Mapping of the Goldmont Plus Microarchitecture

Cluster	Port 0	Port 1	Port 2	Port 3
IEC	ALU0, Shift/Rotate, LEA with no index, F2I, converts/cmp, store_data	ALU1, Bit processing, IMUL, IDIV,POPCNT, CRC32, LEA, I2F, store_data	ALU2, LEA ¹ , I2F, flag_merge	JEU
FPC	SIMD ALU, SIMD shift/Shuffle, SIMD mul, STTNI/AESNI/PCLMULQDQ/SHA ; FP_mul, Converts, F2I convert	SIMD ALU, SIMD shuffle, FP_add, F2I compare		
MEC	Load_addr	Store_addr		

NOTES:

1. LEAs without index can execute on port 0, 1, or 2. LEA with a valid index and displacement are split into multiple UOPs and use both port 1 and 2. LEAs with a valid index execute on port 1.

The MEC owns the MEC RSV and is responsible for scheduling all load and stores via ports 0 and 1. Load and store instructions can go through the address generation phase in order or out-of-order. When out-of-order address generation scheduling is available, memory execution pipeline is de-coupled from the address generation pipeline using the load buffers and store buffers.

With out-of-order execution, situations where loads can pass an unknown store may cause memory order issues if the load eventually depended on the unknown store and would require a pipeline flush when the store address is known. The Goldmont Plus microarchitecture keeps track of and minimizes such potentially problematic load executions.

Memory operations that experienced problems (for example, uTLB misses and unavailable resources) go back to the load or store buffer for re-execution. This allows younger instructions (that do not incur problems) to continue execution rather than stalling all younger instructions. The problematic instruction is later re-issued from the load/store buffer when the problem is resolved. Note that load misses are considered problematic as the data cache is non-blocking and can sustain multiple outstanding misses using write-combining buffers (WCB).

Goldmont Plus microarchitecture includes secondary level TLB changes to support both data and instruction side translations (Goldmont microarchitecture secondary level TLB only supports data).

F.8 CODING RECOMMENDATIONS

Most of the general coding recommendations described in Chapter 3, “General Optimization Guidelines” also apply to the Intel Atom microarchitectures. The rest of this chapter describes techniques that supplement the general recommendations and are specific to the Intel Atom microarchitectures.

F.8.1 Optimizing The Front End

F.8.1.1 Instruction Decoder

Some IA instructions that perform complex tasks require a lookup in the microcode sequencer ROM (MSROM) to decode them into a multiple uop flow. To determine which instructions require an MSROM lookup, see the instruction latency/bandwidth table in Section F.9.

Fewer instructions require MSROM lookup in the Goldmont Plus and Goldmont microarchitecture than in the Silvermont microarchitecture, though the Silvermont microarchitecture also improved significantly over prior generations in this area; Section F.9 provides more details. It is advisable to avoid ucode flows where possible. Table F-11 provides alternate non-MSROM instruction sequences that can replace an instruction that decodes from MSROM.

Table F-11. Alternatives to MSROM Instructions

Instruction from MSROM	Recommendation for Silvermont	Recommendation for Goldmont Plus and Goldmont
CALL m16/m32/m64	Load + CALL reg	Load + CALL reg
PUSH m16/m32/m64	Load + PUSH reg	Use as is (non MSROM)
LEAVE	No recommended replacement	Use as is (non MSROM)
FLD/FST/FSTP m80fp	No recommended replacement	Use as is (non MSROM)
FCOM+FNSTSW	FCOMI	FCOMI
(I)MUL r/m16 (Result DX:AX)	Use (I)MUL r16, r/m16 if extended precision not required, or (I)MUL r32, r/m32	Use (I)MUL r16, r/m16 if extended precision not required, or (I)MUL r32, r/m32
(I)MUL r/m32 (Result EDX:EAX)	Use (I)MUL r32, r/m32 if extended precision not required, or (I)MUL r64, r/m64	Use as is (non MSROM)
(I)MUL r/m64 (Result RDX:RAX)	Use (I)MUL r64, r/m64 if extended precision not required	Use as is (non MSROM)
PEXTRB/D/Q	No recommended replacement	Use as is (non MSROM)
PMULLD	No recommended replacement	Use as is (non MSROM)

Tuning Suggestion 1. Use the perfmon counter `MS_DECODED.MS_ENTRY` to find the number of instructions that need the MSROM (the count will include any assist or fault that occurred).

Assembly/Compiler Coding Rule 1. (M impact, M generality) Try to keep the I-footprint small to get the best reuse of the predecode bits.

Avoid I-cache aliasing/thrashing since the *incorrect* predecode bits result in reduction of decode throughput in one instruction every 3 cycles.

Tuning Suggestion 2. Use the perfmon counter `DECODE_RESTRICTION.PREDECODE_WRONG` to count the number of times that a decode restriction reduced instruction decode throughput because predecoded bits are incorrect.

F.8.1.2 Front End High IPC Considerations

In general front end restrictions are not typically a performance limiter until you reach higher (>1) Instructions Per Cycle (IPC) levels.

The decode restrictions that must be followed to get full decode bandwidth per cycle through the decoders include:

- MSROM instructions should be avoided if possible. A good example is the memory form of CALL near indirect. It will often be better to perform a load into a register and then perform the register version of CALL.
- The total length of the instruction bytes that can be decoded each cycle varies by microarchitecture.
 - Silvermont microarchitecture: up to 16 bytes per cycle with instruction not more than 8 bytes in length. For an instruction length exceeding 8 bytes, only one instruction per cycle is decoded on decoder 0.
 - Goldmont and later microarchitecture: up to 20 bytes per cycle depending on alignment (for example, if the first instruction of three consecutive instructions is aligned on 4-Byte boundary and the 3 instruction sequence meets decode restrictions. For an instruction length exceeding 8 bytes, it is not restricted to decoder 0 or one per cycle.
- An instruction with multiple prefixes can restrict decode throughput. The restriction is on the length of bytes combining prefixes and escape bytes. There is a 3 cycle penalty when the escape/prefix count exceeds the following limits as specified per microarchitectures.
 - Silvermont microarchitecture: the limit is 3 bytes.
 - Goldmont and later microarchitecture: the limit is 4 bytes. Thus, SSE4 or AES instruction that accesses one of the upper 8 registers do not incur a penalty.
 - Only decoder 0 can decode an instruction exceeding the limit of prefix/escape byte restriction on the Silvermont and Goldmont microarchitectures.
- The maximum number of branches that can be decoded each cycle is 1 for the Silvermont microarchitecture and 2 for the Goldmont microarchitecture. Prevent a re-steer penalty by avoiding back-to-back conditional branches.

Unlike the previous generation, the Silvermont and later microarchitectures can decode two x87 instructions in the same cycle without incurring a 2-cycle penalty. Branch decoder restrictions are also relaxed. In earlier Intel Atom processors, decoding past a conditional or indirect branch in decoder 0 resulted in a 2-cycle penalty.

The Silvermont microarchitecture can decode past conditional and indirect branch instructions in decoder 0. However, if the next instruction (on decoder 1) is also a branch, there is a 3-cycle penalty for the second branch instruction.

The Goldmont and later microarchitecture can decode one predicted not-taken branches in decoder 0 or decoder 1, plus another branch in decoder 2 without the 3-cycle re-steer penalty. However, if there are two predicted not-taken branches at decoder 0 and 1, the second branch at decoder 1 will incur a 3-cycle penalty.

For a branch target that is a predicted taken conditional branch or unconditional branch, it is decoded with a one cycle bubble across all generations of Intel Atom processors.

Assembly/Compiler Coding Rule 2. (MH impact, H generality) Minimize the use of instructions that have the following characteristics to achieve more than one instruction per cycle throughput: (i) using the MSROM, (ii) exceeding the limit of escape/prefix bytes, (iii) more than 8 bytes long, or (iv) have back to back branches.

For example, an instruction with 3 bytes of prefix/escape and accessing the lower 8 registers can decode normally in the Silvermont, Goldmont and later microarchitectures. For instance:

```
PCLMULQDQ 66 0F 3A 44 C7 01 pclmulq dq xmm0, xmm7, 0x1
```

To access any of the upper 8 XMM registers, XMM8-15, an additional byte with REX prefix is necessary. Consequently, it will decode normally in the Goldmont and later microarchitecture, but incur a decode penalty in the Silvermont microarchitecture. For instance:

```
PCLMULQDQ 66 41 0F 3A 44 C0 01 pclmulq dq xmm0, xmm8, 0x1
```

(Note the REX byte 41, in between the 66 and the 0F 3A.)

The 3-cycle penalty applies whenever the combined prefix/escape bytes exceed the decode restriction limit. Also, it forces the instruction to be decoded on decoder 0. Additionally, when decoding an instruction exceeding the prefix/escape length limit, not on decoder 0, there is an extra delay to re-steer to decoder 0 (for a total of a 6 cycle penalty for the decoder). Therefore, when hand writing high performance assembly, be aware of these cases. It would be beneficial to pre-align these cases to decoder 0 if they occur infrequently using a taken branch target or MS entry point as a decoder 0 alignment vehicle. NOP insertion should be used only as a last resort as NOP instructions consume resources in other parts of the pipeline. Similar alignment is necessary for MS entry points which suffer the additional 3 cycle penalty if they align originally to decoder 1. The penalty associated with a prefix/escape length limit and re-steer apply to both Silvermont, Goldmont and later microarchitectures.

Table F-12 compares decoder capabilities between microarchitectures.

Table F-12. Comparison of Decoder Capabilities

	Goldmont Plus and Goldmont Microarchitecture	Silvermont Microarchitecture
Width	3	2
Max Throughput	20 bytes per cycle (1st instr. aligned to 4B boundary and decoder 1 and 2 restrictions)	16 bytes per cycle (1st instr. <= 8 bytes)
Prefix/Escape Limit	4 bytes	3 bytes
Branch	2	1

F.8.1.3 Branching Across 4GB Boundary

Another important performance consideration from a front end standpoint is branch prediction. For 64-bit applications, branch prediction performance can be negatively impacted when the target of a branch is more than 4GB away from the branch. This is more likely to happen when the application is split into shared libraries. Newer glibc versions can put the shared libraries into the first 2GB to avoid this problem (since 2.23). The environment variable LD_PREFER_MAP_32BIT_EXEC=1 has to be set. Developers can build statically to improve the locality in their code. Building with LTO should further improve performance.

F.8.1.4 Loop Unrolling and Loop Stream Detector

The Silvermont and later microarchitectures include a Loop Stream Detector (LSD) that provides the back end with uops that are already decoded. This provides performance and power benefits. When the LSD is engaged, front end decode restrictions, such as number of prefix/escape bytes and instruction length, no longer apply.

One way to reduce the overhead of loop maintenance code and increase the amount of independent work in a loop is software loop unrolling. Unfortunately care must be taken on where it is utilized because loop unrolling has both positive and negative performance effects. The negative performance effects are caused by the increased code size and increased BTB and register pressure. Furthermore, loop unrolling can increase the loop size beyond the limits of the LSD. The LSD loop size limit varies with microarchitecture; it is 27 for the Goldmont and later microarchitecture with a three-wide decoder, and 28 for the Silvermont microarchitecture. Care must be taken to keep the loop size under the LSD limit.

User/Source Coding Rule 1. (M impact, M generality) *Keep per-iteration instruction count below 28 when considering loop unrolling technique on short loops with high iteration count.*

Tuning Suggestion 3. *Use the BACLEARS.ANY perfmon counter to see if the loop unrolling is causing too much pressure. Use the ICACHE.MISSES perfmon counter to see if loop unrolling is having an excessive negative effect on the instruction footprint.*

F.8.1.5 Mixing Code and Data

Intel Atom processors perform best when code and data are on different pages. Software should avoid sharing code and data in the same page to avoid false SMC conditions. This recommendation applies to all page sizes.

F.8.2 Optimizing The Execution Core

F.8.2.1 Scheduling

The Silvermont microarchitecture is less sensitive to instruction ordering than its predecessors due to the introduction of out-of-order execution for integer instructions. FP instructions have their own reservation stations but still execute in order with respect to each other. Memory instructions also issue in order but with the addition of the Rehab Queue, they can complete out of order and memory system delays are no longer blocking.

The Goldmont and later microarchitecture features fully out-of-order execution across the IEC, FPC, and MEC pipelines, and is supported by enhancements ranging from 3 ports for IEC, 128-bit data path of FPC units, dedicated load address and store address pipelines.

Tuning Suggestion 4. *Use the perfmon counter UOPS_NOT_DELIVERED.ANY (NO_ALLOC_CYCLE.ANY on Silvermont microarchitecture) as an indicator of performance bottlenecks in the back end. This includes delays in the memory system and execution delays.*

F.8.2.2 Address Generation

The Silvermont microarchitecture eliminated address generation limitations in previous generations. As such, using LEA or ADD instructions to generate addresses are equally effective on the Silvermont and later microarchitectures.

The rule of thumb for ADDs and LEAs is that it is justified to use LEA with a valid index and/or displacement for non-destructive destination purposes (especially useful for stack offset cases), or to use a SCALE. Otherwise, ADD(s) are preferable.

F.8.2.3 FP Multiply-Accumulate-Store Execution

With Goldmont and later microarchitectures, a unified FPC reservation station eliminates the performance issue that can happen in the Silvermont microarchitecture due to intra-port dependence of in-order scheduling of FPC uops. The paragraphs below and Example F-7 illustrate the problem.

FP arithmetic instructions executing on different ports can execute out-of-order with respect to each other in the Silvermont microarchitecture. As a result, in unrolled loops with multiplication results feeding into add instructions which in turn produce results for store instructions, grouping the store instructions at the end of the loop will improve performance. This allows it to overlap the execution of the multiplies and the adds. Consider the example shown in Example F-7.

Example F-7. Unrolled Loop Executes In-Order Due to Multiply-Store Port Conflict

Instruction	1	2	3	4	5	6	7	8	9	10	11	12	13	14	15	16	17	18
mulps, xmm1, xmm1	E	E	E	E	E													
	X	X	X	X	X													
	1	2	3	4	5													
addps xmm1, xmm1						E	E	E										
						X	X	X										
						1	2	3										
movaps mem, xmm1									E									
									X									
									1									
mulps, xmm2, xmm2										E	E	E	E	E				
										X	X	X	X	X				
										1	2	3	4	5				
addps xmm2, xmm2															E	E	E	
															X	X	X	
															1	2	3	
movaps mem, xmm2																		E
																		X
																		1

Due to the data dependence, the add instructions cannot start executing until the corresponding multiply instruction is executed. Because multiplies and stores use the same port, they have to execute in program order. This means the second multiply instruction cannot start execution even though it is independent from the first multiply and add instructions. If you group the store instructions together at the end of the loop as shown below, the second multiply instruction can execute in parallel with the first multiply instruction (note the 1 cycle bubble when multiplies are overlapped).

Example F-8. Grouping Store Instructions Eliminates Bubbles and Improves IPC

Instruction	1	2	3	4	5	6	7	8	9	10	11
mulps, xmm1, xmm1	EX1	EX2	EX3	EX4	EX5						
addps xmm1, xmm1						EX1	EX2	EX3			
mulps, xmm2, xmm2		bubble	EX1	EX2	EX3	EX4	EX5				
addps xmm2, xmm2								EX1	EX2	EX3	
movaps mem, xmm1									EX1		
movaps mem, xmm2											EX1

F.8.2.4 Integer Multiply Execution

The Silvermont and later microarchitectures have a dedicated integer multiplier to accelerate commonly-used forms of integer multiply flows. Table F-13 shows the latency and instruction forms of mul/imul instructions that are accelerated and not using MSROM.

Table F-13. Integer Multiply Operation Latency

Integer Multiply Operations	Output	Goldmont Plus and Goldmont Latency	Silvermont Latency
imul/mul r/m8	16	4 ^u	5 ^u
imul/mul r/m16	32	4 ^u	5 ^u
imul/mul r/32	64	3	4 ^u
imul/mul r/m64	128	5	7 ^u
imul/mul r16, r/m16; r16, r/m16, imm	16	4 ^u	4 ^u
imul/mul r32, r/m32; r32, r/m32, imm	32	3	3
imul/mul r64, r/m64; r64, r/m64, imm8	64	5	5

u: ucode flow from MSROM

The multiply forms with microcode flows should be avoided.

F.8.2.5 Zeroing Idioms

XOR / PXOR / XORPS / XORPD instructions are commonly used to force register values to zero when the source and the destination register are the same (e.g. XOR eax, eax).

This method of zeroing is preferred by compilers instead of the equivalent MOV eax, 0x0 instructions as the MOV encoding is larger than the XOR in code bytes.

The Silvermont and later microarchitectures have special hardware support to recognize these cases and mark both the sources as valid in the architectural register file. This helps the XOR execute faster since any value XORed with itself will accomplish the necessary zeroing.

The logic will also support PXOR, XORPS, and XORPD idioms.

In Silvermont microarchitecture, zero-idiom, a 64-bit general purpose operand using REX.W, will experience delay. However, zero-idiom is supported with XMM8-XMM15 or the upper 8 general purpose registers without REX.W. To clear r8, it is sufficient to use XOR r8d, r8d.

Goldmont and later microarchitecture supports these zero-idioms for 64-bit operands.

F.8.2.6 NOP Idioms

NOP instruction is often used for padding or alignment purposes. The Goldmont and later microarchitecture has hardware support for NOP handling by marking the NOP as completed without allocating it into the reservation station. This saves execution resources and bandwidth. Retirement resource is still needed for the eliminated NOP.

F.8.2.7 Move Elimination and ESP Folding

Move elimination is supported in Goldmont and later microarchitecture. When move elimination is in effect, these instructions can execute with higher throughput in addition to 0 cycle latency. Specifically, 32-bit and 64-bit operand size of MOV, and MOVAPS/MOVAPD/MOVDQA/MOVDQU/MOVUPS/MOVUPD with XMM are supported and have throughput of 0.33 cycle if move elimination is in effect. MOVZX and MOVZX do not support move elimination.

Stack operation using PUSH/POP/CALL/RET is more efficient with the Goldmont and later microarchitecture than with the Silvermont microarchitecture. Computing the stack pointer address does

not consume allocation and execution resources in the Goldmont and later microarchitecture. Additionally, throughput of PUSH/POP is increased from 1 to 3 per cycle.

F.8.2.8 Stack Manipulation Instruction

The memory forms of indirect CALL m16/m32/m64 are decoded into a uop flow from MSROM. Indirect CALL with target specified in a register can avoid the delays. Thus, loading the target address to a register, followed by an indirect CALL via register operand is recommended.

In the Goldmont and later microarchitecture, PUSH m16/m32/m64 do not require MSROM to decode. The same is also true with the LEAVE instruction.

In the Silvermont microarchitecture, PUSH m16/m32/m64 and LEAVE require MSROM to decode.

F.8.2.9 Flags usage

Many instructions have an implicit data result that is captured in a flags register. These results can be consumed by a variety of instructions such as conditional moves (cmovs), branches and even a variety of logic/arithmetic operations (such as rcl). The most common instructions used in computing branch conditions are compare instructions (CMP). Branches dependent on the CMP instruction can execute in the next cycle. The same is true for branch instructions dependent on ADD or SUB instructions.

INC and DEC instructions require an additional uop to merge the flags as they are partial flag writers. As a result, a branch instruction depending on an INC or a DEC instruction incurs a 1 cycle penalty.

Note that this penalty only applies to branches that are directly dependent on the INC or DEC instruction.

Assembly/Compiler Coding Rule 3. (M impact, M generality) Use CMP/ADD/SUB instructions to compute branch conditions instead of INC/DEC instructions whenever possible.

F.8.2.10 SIMD Floating-Point and X87 Instructions

In the Silvermont microarchitecture, only a subset of the SIMD FP execution units are implemented with a 128-bit wide data path. In Goldmont and later microarchitecture, SIMD FP units are implemented with a 128-bit data path. In general, packed SIMD instructions complete with one cycle less in latency and twice the throughput in the Goldmont and later microarchitecture, compared to the Silvermont microarchitecture.

In particular, MULPD latency is accelerated from 7 to 4 cycles, with 4-fold throughput from every 4 cycles to 1 per cycle.

Latency and throughput of X87 extended precision load and store, FLD m80fp, and FST/FSTP m80fp are also improved in the Goldmont and later microarchitecture. See Table F-19 for more details.

In the Goldmont Plus microarchitecture, Floating point divider is upgraded to radix-1024 based design. Floating point divide and square root latency and bandwidth are significantly improved. See Table 15-14 for more details.

F.8.2.11 SIMD Integer Instructions

In the Silvermont microarchitecture, a relatively small subset of the SIMD integer instructions can execute with throughput of two instructions per cycle. In the Goldmont and later microarchitecture, many more SIMD integer instructions can complete at a rate of two instructions per cycle.

Latency and/or throughput improvements in the Goldmont and later microarchitecture include other SIMD integer instructions that execute only one port. For example, PMULLD has an 11 cycle latency and throughput of one every 11 cycles in the Silvermont microarchitecture. It has 5 cycle latency and throughput of one every 2 cycles in the Goldmont and later microarchitectures.

In general, SIMD integer multiply hardware is significantly faster (4 cycle latency) and higher throughput (1 cycle throughput) than in the Silvermont microarchitecture. Additionally, PADDQ/PSUBQ has 2 cycle latency and throughput of every 2 cycles, compared to 4 cycle latency and throughput every 4 cycles in the Silvermont microarchitecture. PSHUFB has 1 cycle latency and throughput in the Goldmont and later

microarchitectures, compared to 5 cycle latency and throughput of every 5 cycles. See Table F-19 for more details.

F.8.2.12 Vectorization Considerations

In the Silvermont microarchitecture, opportunity for profitable vectorization may be limited by the availability of high-throughput implementation SIMD execution units or SIMD instructions that require MSROM to decode into longer flows.

The Goldmont and later microarchitectures allows compiler, as well as direct programming, to profit from vectorization due to improvement in latency and throughput across a wide variety of SIMD instructions.

Assembly/Compiler Coding Rule 4. (M impact, M generality) *Avoid MSROM instructions for code vectorization.*

F.8.2.13 Other SIMD Instructions

The Silvermont microarchitecture supports AESNI and PCLMULQDQ to accelerate performance of various cryptographic algorithms like AES and AES-GCM for block encryption/decryption.

In the Goldmont and later microarchitectures, the execution hardware is improved from execution latency, throughput to decode throughput. For example, PCLMULQDQ has latency of 6 cycles with throughput of every 4 cycles in the Goldmont microarchitecture, compared to 10 cycle latency and throughput of every 10 cycles in the Silvermont microarchitecture.

Additionally, the Goldmont and later microarchitecture supports SHANI to accelerate the performance of secure hashing algorithms like SHA1 and SHA256. More details about the secure hashing algorithms and SHANI can be found at

<https://software.intel.com/en-us/articles/intel-sha-extensions>.

Examples and reference implementation of using the Intel SHA extensions can be found at:

<https://software.intel.com/en-us/articles/intel-sha-extensions-implementations>.

F.8.2.14 Instruction Selection

Table F-14 summarizes the latency for floating-point and SIMD integer operations in the Silvermont microarchitecture. The throughput column is expressed in number of cycles per instruction that execution can complete with all available execution units employed (for example, 4 indicates the same instruction can complete execution every 4 cycles; 0.33 indicates 3 identical instructions can complete execution each cycle).

Table F-14. Floating-Point and SIMD Integer Latency

	Goldmont Plus		Goldmont		Silvermont	
	Latency	Through put	Latency	Through put	Latency	Through put
SIMD integer ALU						
128-bit ALU/logical/move	1	0.5	1	0.5	1	0.5
64-bit ALU/logical/move	1	0.5	1	0.5	1	0.5
SIMD integer shift						
128-bit	1	0.5	1	0.5	1	1
64-bit	1	0.5	1	0.5	1	1
SIMD shuffle						
128-bit	1	0.5	1	0.5	1	1
64-bit	1	0.5	1	0.5	1	1
SIMD integer multiplier						
128-bit	4	1	4	1	5	2
64-bit	4	1	4	1	4	1
FP Adder						
x87 (fadd)	3	1	3	1	3	1
scalar (addsd, addss)	3	1	3	1	3	1
packed (addpd, addps)	3	1	3	1	4	2
FP Multiplier						
x87 (fmul)	5	2	5	2	5	2
scalar single-precision (mulss)	4	1	4	1	4	1
scalar double-precision (mulsd)	4	1	4	1	5	2
packed single-precision (mulps)	4	1	4	1	5	2
packed double-precision (mulpd)	4	1	4	1	7	4
Converts						
CVTDQ2PD, CVTDQ2PS, CVTPD2DQ, CVTPD2PI, CVTPD2PS, CVTPI2PD, CVTPS2DQ, CVTPS2PD, CVTTPD2DQ, CVTPD2PI, CVTPS2DQ	4	1	4	1	5	2
CVTPI2PS, CVTPS2PI, CVTSD2SI, CVTSD2SS, CVTSI2SD, CVTSI2SS, CVTSS2SD, CVTSS2SI, CVTTPS2PI, CVTTSD2SI, CVTTSS2SI	4	1	4	1	4	1

Table F-14. Floating-Point and SIMD Integer Latency (Contd.)

	Goldmont Plus		Goldmont		Silvermont	
	Latency	Throughput	Latency	Throughput	Latency	Throughput
FP Divider						
x87 fdiv (extended-precision)	15	11	39	39	39	39
x87 fdiv (double-precision)	14	10	34	34	34	34
x87 fdiv (single-precision)	11	7	19	19	19	19
scalar single-precision (divss)	11	7	19	18	19	17
scalar double-precision (divsd)	14	10	34	33	34	32
packed single-precision (divps)	16	12	36	35	39	39
packed double-precision (divpd)	22	18	66	65	69	69

Note that scalar SSE single precision multiples are one cycle faster than most FP operations. From inspection of the table you can also see that packed SSE doubles have a slightly larger latency and smaller throughput compared to their scalar counterparts.

Assembly/Compiler Coding Rule 5. (M impact, M generality) Favor SSE floating-point instructions over x87 floating point instructions.

Assembly/Compiler Coding Rule 6. (MH impact, M generality) Run with exceptions masked and the DAZ and FTZ flags set (whenever possible).

Tuning Suggestion 5. Use the perfmon counters MACHINE_CLEAR.SFP_ASSIST to see if floating exceptions are impacting program performance.

F.8.2.15 Integer Division

In Silvermont microarchitecture, integer division requires microcode flows that are relatively long and slow. Its latency can vary profoundly on the input value and data sizes. In Goldmont and later microarchitecture, there is hardware enhancement for short-precision forms of DIV/IDIV without using MSROM. DIV/IDIV forms needing higher precision do use MSROM, but are also accelerated from the hardware enhancement. Table F-15 and Table 6-16 show the latency range for divide instructions, and the instructions that require MSROM are noted with the superscript 'u'.

Table F-15. Unsigned Integer Division Operation Latency

	Dividend	Divisor	Quotient	Remainder	Silvermont ^u	Goldmont Plus/Goldmont
DIV r8	AX	r8	AL	AH	25	11-12
DIV r16	DX:AX	r16	AX	DX	26-30	12-17 ^u
DIV r32	EDX:EAX	r32	EAX	EDX	26-38	12-25 ^u
DIV r64	RDX:RAX	r64	RAX	RDX	38-123	12-41 ^u

Table 6-16. Signed Integer Division Operation Latency

	Dividend	Divisor	Quotient	Remainder	Silvermont ^u	Goldmont Plus/Goldmont
IDIV r8	AX	r8	AL	AH	34	11-12
IDIV r16	DX:AX	r16	AX	DX	35-40	12-17 ^u
IDIV r32	EDX:EAX	r32	EAX	EDX	35-47	12-25 ^u
IDIV r64	RDX:RAX	r64	RAX	RDX	49-135	12-41 ^u

User/Source Coding Rule 2. (M impact, L generality) Use divides only when really needed and take care to use the correct data size and sign so that you get the most efficient execution.

Tuning Suggestion 6. Use the perfmon counter `CYCLES_DIV_BUSY.ANY` to see if the divides are a bottleneck in the program.

If one needs unaligned groups of packed singles where the whole array is aligned, the use of `PALIGNR` is recommend over `MOVUPS`. For instance, load `A[x+y+3:x+y]` where `x` and `y` are loop variables; it is better to calculate `x+y`, round down to a multiple of 4 and use a `MOVAPS` and `PALIGNR` to get the elements (rather than a `MOVUPS` at `x+y`). While this may look longer, the integer operations can execute in parallel to FP ones. This will also avoid the periodic `MOVUPS` that splits a line at the cost of approximately 6 cycles.

User/Source Coding Rule 3. (M impact, M generality) Use `PALIGNR` when stepping through packed single elements

F.8.2.16 Integer Shift

When using an integer shift instruction with shift count in a register (i.e., `CL`), there is a one cycle bubble for scheduling if the count register is produced by the preceding instruction in the execution pipeline. Thus, the instruction producing the shift count should be hoisted whenever possible.

Additionally, double shift instructions (`SHLD/SHRD`) operating on 64-bit input data require long MSROM flows. In the Silvermont microarchitecture, `SHRD` with a 32-bit destination register and immediate shift count is decoded from the MSROM but the corresponding `SHLD` is not. In the Goldmont and later microarchitecture, `SHLD/SHRD` with 32-bit destination register and immediate shift count are not decoded from the MSROM. `SHLD/SHRD` with 32-bit destination memory operand or with `CL` shift count are decoded from the MSROM on both Silvermont and Goldmont.

F.8.2.17 Pause Instruction

In the Goldmont and later microarchitecture, the latency of the `PAUSE` instruction is similar to that of the Skylake microarchitecture to achieve better power saving with thread synchronization primitives.

F.8.3 Optimizing Memory Accesses

F.8.3.1 Reduce Unaligned Memory Access with `PALIGNR`

When working with single-precision FP or dword data arrays, loading 4 consecutive elements often encounter memory accesses that are not 16-Byte aligned. For example, a nested loop iteration with an array using two iterating indices, `'i', 'j'` in `A[i + j]`. When loading 16 bytes from memory using `"i+j"` as the effective index that increments by 1 in an inner loop, unaligned access will occur 3 of 4 accesses.

These unaligned memory access can be avoided. Assuming the base of the array is 16-Bytes aligned, loading 16 bytes should be done with an effective index that is a multiple of 4, followed by `PALIGNR` with two consecutive 16-byte chunks already loaded in XMM, with the `imm8` constant derived from `4*remainder of the original "i+j"`.

Assembly/Compiler Coding Rule 7. (M impact, M generality) Use `PALIGNR` when stepping through packed single-precision FP or dword elements.

F.8.3.2 Minimize Memory Execution Issues

In the Goldmont and later microarchitecture, fully out-of-order execution in the MEC allows loads to pass older stores which have not yet resolved their address. If the load did depend on the older store, the hardware detects this situation and the load and subsequent operations need to be re-executed. The programmer can use a performance counter event to assess and locate the cause of such re-execution.

In the Silvermont microarchitecture, its RehabQ needs to deal with several types of execution problems in the MEC. The issues include: load blocks, load/store splits, locks, TLB misses, unknown addresses, and too many stores. *The perfmon counter's REHABQ* in the Silvermont microarchitecture can be used to assess problems specific to the Silvermont microarchitecture.

Tuning Suggestion 7. Use the perfmon counters `MACHINE_CLEAR.DISAMBIGUATION` to assess the impact of loads passing older unknown stores on application performance with the Goldmont microarchitecture and its descendants.

F.8.3.3 Store Forwarding

Forwarding is significantly improved in the Silvermont and later microarchitectures compared to prior generations. A store instruction will forward its data to a receiving load instruction if the following are true:

- The forwarding store and the receiving load start at the same address.
- The receiving load is smaller than or equal to the forwarding store in terms of width.
- The forwarding store or the receiving load do not incur cache line splits.

Table F-17 and Table F-18 illustrate various situations of successful forwarding versus situations where preceding stores cannot be forwarded.

Table F-17. Store Forwarding Conditions (1 and 2 Byte Stores)

		Load Alignment															
Store Size	Load Size	0	1	2	3	4	5	6	7	8	9	10	11	12	13	14	15
1	1	F															
2	1	F	N														
	2	F	N														

Table F-18. Store Forwarding Conditions (4-16 Byte Stores)

		Load Alignment															
Store Size	Load Size	0	1	2	3	4	5	6	7	8	9	10	11	12	13	14	15
4	1	F	N	F	N												
	2	F	N	F	N												
	4	F	N	N	N												

Table F-18. Store Forwarding Conditions (4-16 Byte Stores)

		Load Alignment															
8	1	F	N	N	N	N	N	N	N	N							
	2	F	N	N	N	N	N	N	N								
	4	F	N	N	N	N	N	N	N								
	8	F	N	N	N	N	N	N	N								
16	1	F	N	N	N	N	N	N	N	N	N	N	N	N	N	N	N
	2	F	N	N	N	N	N	N	N	N	N	N	N	N	N	N	N
	4	F	N	N	N	N	N	N	N	N	N	N	N	N	N	N	N
	8	F	N	N	N	N	N	N	N	N	N	N	N	N	N	N	N
	16	F	N	N	N	N	N	N	N	N	N	N	N	N	N	N	N

If one (or more) of these conditions is not satisfied, the load is blocked and put into the RehabQ to reissue again.

To eliminate/avoid store forwarding problems, use the guidelines below (in order of preference):

- Use registers instead of memory.
- Hoist the store as early as possible (stores happen later in the pipeline than loads, so the store needs to be hoisted many instructions earlier than the load).

The cost of a successful forwarding varies with microarchitectures. The cost is 3 cycles in the Silvermont microarchitecture (that is, if the store executes at cycle n , the load will execute at cycle $n+3$). The cost is 4 cycles in the Goldmont microarchitecture. Intel Goldmont Plus microarchitecture optimizes certain store data from register operation to reduce store to load forwarding latency to 3 cycle.

F.8.3.4 PrefetchW Instruction

The Silvermont and later microarchitectures support the PrefetchW instruction (0f 0d /1). This instruction is a hint to the hardware to prefetch the specified line into the cache with a read-for-ownership request. This can allow later stores to that line to complete faster than they would if the line was not prefetched or was prefetched with a different instruction. All prefetch instructions may cause performance loss if misused. Care should be used to ensure that prefetch instructions, including PrefetchW, actually improve performance. The instruction opcode 0f 0d /0 continues to be a NOP. It does not prefetch the indicated line.

F.8.3.5 Cache Line Splits and Alignment

Cache line splits cause load and store instructions to operate at reduced bandwidth. As a result, they should be avoided where possible.

Tuning Suggestion 8. Use the `REHABQ.ST_SPLIT` and `REHABQ.LD_SPLIT` perfmon counters to locate splits, and to count the number of split operations.

While aligned accesses are preferred, the Silvermont microarchitecture has hardware support for unaligned references. As such, `MOVUPS/MOVUPD/MOVDQU` instructions are all single UOP instructions in contrast to previous generation Intel Atom processors.

F.8.3.6 Segment Base

For simplicity, the AGU in the Silvermont microarchitecture assumes that the segment base will be zero. However, while studies have shown that this is overwhelmingly true, there are times when a non-zero segment base (NZB) must be used. When using NZBs, keep the segment base cache line (0x40) aligned if at all possible. NZB address generation involves a 1 cycle penalty in the Silvermont microarchitecture. In Goldmont and later microarchitecture, NZB address generation can maintain one per cycle.

F.8.3.7 Copy and String Copy

Compilers typically provide libraries with memcpy/memset routines that provide good performance while managing code size and alignment issues.

Memcpy and memset operation can be accomplished using REP MOVSB/STOS instructions with length of operation decomposed for optimized byte/dword granular operations and alignment considerations. This usually provides a decent copy/set solution for the general case. The REP MOVSB/STOS instructions have a fixed overhead. REP STOS should be able to cope with line splits for long strings; but REP MOVSB cannot due to the complexity of the possible alignment matches between source and destination.

For specific copy/set needs, macro code sequence using SIMD instruction can provide modest gains (on the order of a dozen clocks or so), depending on the alignment, buffer length, and cache residency of the buffers. Large memory copies with cache line splits are a notable exception to this rule, where careful macrocode might avoid the cache lines splits and substantially improve on REP MOV.

Processors based on the Silvermont microarchitecture support the Enhanced REP MOVSB and STOSB operation feature. REP string operations using MOVSB and STOSB can provide the smallest code size with both flexible and high performance REP string operations for software in common situations like memory copy and set operations. Processors that provide enhanced MOVSB/STOSB operations are enumerated by the CPUID feature flag: CPUID:(EAX=7H, ECX=0H):EBX.[bit 9] = 1.

Software wishing to have a simple default string copy or store routine that will work well on a range of implementations (including future implementations) should consider using REP MOVSB or REP STOSB on implementations that support Enhanced REP MOVSB and STOSB. Although these instructions may not be as fast on a specific implementation as a more specialized copy/store routine, such specialized routines may not perform as well on future processors and may not take advantage of future enhancements. REP MOVSB and REP STOSB will continue to perform reasonably well on future processors.

F.9 INSTRUCTION LATENCY AND THROUGHPUT

This section lists the throughput and latency information of recent microarchitectures for Intel Atom processor generations. Instructions that require decoder assistance from MSROM are marked in the "Comment" column (instructions marked with 'Y' should be used minimally if more decode-efficient alternatives are available). Throughput and latency values for various instructions are grouped by the respective microarchitecture according to its CPUID DisplayFamily_DisplayModel. When a large number of DisplayModels of the same DisplayFamily have the same time timing characteristics, the DisplayFamily may be listed only once.

The microarchitectures and corresponding DisplayFamily_DisplayModel signature covered in this section are:

- Goldmont Plus microarchitecture: 06_7AH. Note that if Goldmont Plus microarchitecture differs from Goldmont in value, this will be indicated by the addition of "(GLP)" next to the value in the table below.
- Goldmont microarchitecture: 06_5CH, 06_5FH.
- Silvermont or Airmont microarchitecture: 06_37H, 06_4AH, 06_4CH, 06_4DH, 06_5AH, 06_5DH

Table F-19. Instructions Latency and Throughput Recent Microarchitectures for Intel Atom® Processors

Instruction	Throughput		Latency		MSROM	
	06_5CH, 5FH, 7AH	06_37H, 4AH,4CH ,4DH,5A H,5DH	06_5CH, 5FH, 7AH	06_37H, 4AH,4CH, 4DH,5AH, 5DH	06_5CH ,5FH, 7AH	06_37H, 4AH,4C H,4DH,5 AH,5DH
ADC/SBB r32, imm8	1	2	2	2	N	N
ADC/SBB r32, r32	1	2	2	2	N	N
ADC/SBB r64, r64	1	2	2	2	N	N

Table F-19. Instructions Latency and Throughput Recent Microarchitectures for Intel Atom® Processors (Contd.)

Instruction	Throughput		Latency		MSROM	
	06_5CH, 5FH, 7AH	06_37H, 4AH,4CH ,4DH,5A H,5DH	06_5CH, 5FH, 7AH	06_37H, 4AH,4CH, 4DH,5AH, 5DH	06_5CH ,5FH, 7AH	06_37H, 4AH,4C H,4DH,5 AH,5DH
ADD/AND/CMP/OR/SUB/XOR/TEST r32, r32	0.33	0.5	1	1	N	N
ADD/AND/CMP/OR/SUB/XOR/TEST r64, r64	0.33	0.5	1	1	N	N
ADDPD/ADDSUBPD/MAXPD/MINPD/SUBPD xmm, xmm	1	2	3	4	N	N
ADDP/ADDSD/ADDSS/ADDSUBPS/SUBPS/SUBSD/SUBSS	1	1	3	3	N	N
MAXPS/MAXSD/MAXSS/MINPS/MINSD/MINSS xmm, xmm	1	1	3	3	N	N
ANDNPD/ANDNPS/ANDPD/ANDPS/ORPD/ORPS/XORPD/XORPS	0.5	0.5	1	1	N	N
AESDEC/AESDECLAST/AEENC/AEENCLAST	2 1 (GLP)	5	6 4 (GLP)	8	N	Y
AESIMC/AESKEYGEN	2 1 (GLP)	5	5 4 (GLP)	8	N	Y
BLENDPD/BLENDPS xmm, xmm, imm8	0.5	1	1	1	N	N
BLENDVPD/BLENDVPS xmm, xmm	4	4	4	4	Y	Y
BSF/BSR r32, r32	8	10	10	10	Y	Y
BSWAP r32	1	1	1	1	N	N
BT/BTC/BTR/BTS r32, r32	1	1	1	1	N	N
CBW	4	4	4	4	Y	Y
CDQ/CLC/CMC	1	1	1	1	N	N
CMOVB r32; r32	1	1	2	2	N	N
CMPPD xmm, xmm, imm	1	2	3	4	N	N
CMPSD/CMPPS/CMPSS xmm, xmm, imm	1	1	3	3	N	N
CMPXCHG r32, r32	5	6	5	6	Y	Y
CMPXCHG r64, r64	5	6	5	6	Y	Y
(U)COMISD/(U)COMISS xmm, xmm;	1	1	4	4	N	N
CPUID	58	60	58	60	Y	Y
CRC32 r32, r32	1	1	3	3	N	N
CRC32 r64, r64	1	1	3	3	N	N
CVTDQ2PD/CVTDQ2PS/CVTPD2DQ/CVTPD2PS xmm, xmm	1	2	4	5	N	N
CVT(T)PD2PI/CVT(T)PI2PD	1	2	4	5	N	N
CVT(T)PS2DQ/CVTPS2PD xmm, xmm;	1	2	4	5	N	N
CVT(T)SD2SS/CVTSS2SD xmm, xmm	1	1	4	4	N	N
CVTSI2SD/SS xmm, r32	1	1	7	6	N	N
CVTSD2SI/SS2SI r32, xmm	1	1	4	4	N	N
DEC/INC r32	1	1	1	1	N	N

Table F-19. Instructions Latency and Throughput Recent Microarchitectures for Intel Atom® Processors (Contd.)

Instruction	Throughput		Latency		MSROM	
	06_5CH, 5FH, 7AH	06_37H, 4AH,4CH ,4DH,5A H,5DH	06_5CH, 5FH, 7AH	06_37H, 4AH,4CH, 4DH,5AH, 5DH	06_5CH ,5FH, 7AH	06_37H, 4AH,4C H,4DH,5 AH,5DH
DIV r8	11-12	25	11-12	25	N	Y
DIV r16	12-17	26-30	12-17	26-30	Y	Y
DIV r32	12-25	26-38	12-25	26-38	Y	Y
DIV r64	12-41	38-123	12-41	38-123	Y	Y
DIVPD ¹	12, 65 18 (GLP)	27-69	13, 66 22 (GLP)	27-69	N	Y
DIVPS ¹	12, 35 12 (GLP)	27-39	13, 36 16 (GLP)	27-39	N	Y
DIVSD ¹	12, 33 10 (GLP)	11-32	13, 34 14 (GLP)	13-34	N	N
DIVSS ¹	12, 18 7 (GLP)	11-17	13, 19 11 (GLP)	13-19	N	N
DPPD xmm, xmm, imm	5	8	8	12	Y	Y
DPPS xmm, xmm, imm	11	12	14	15	Y	Y
EMMS	23	10	23	10	Y	Y
EXTRACTPS	1	4	4	5	N	Y
F2XM1	87	88	87	88	Y	Y
FABS/FCBS	0.5	1	1	1	N	N
FCOM	1	1	4	4	N	N
FADD/FSUB	1	1	3	3	N	N
FCOS	154	168	154	168	Y	Y
FDECSTP/FINCSTP	0.5	0.5	1	1	N	N
FDIV	39 11 (EP GLP)	39	39 15 (EP GLP)	39	N	N
FLDZ	280	277	280	277	Y	Y
FMUL	2	2	5	5	N	N
FPATAN/FYL2X/FYL2XP1	303	296	303	296	Y	Y
FPTAN/FSINCOS	287	281	287	281	Y	Y
FRNDINT	41	25	41	25	Y	Y
FSCALE	32	74	32	74	Y	Y
FSIN	140	150	140	150	Y	Y
FSQRT	40	40	40	40	N	N
HADDPD/HSUBPD xmm, xmm	5	5	5	6	Y	Y
HADDPS/HSUBPS xmm, xmm	6	6	6	6	Y	Y
IDIV r8	11-12	34	11-12	34	N	Y
IDIV r16	12-17	35-40	12-17	35-40	Y	Y

Table F-19. Instructions Latency and Throughput Recent Microarchitectures for Intel Atom® Processors (Contd.)

Instruction	Throughput		Latency		MSROM	
	06_5CH, 5FH, 7AH	06_37H, 4AH,4CH ,4DH,5A H,5DH	06_5CH, 5FH, 7AH	06_37H, 4AH,4CH, 4DH,5AH, 5DH	06_5CH ,5FH, 7AH	06_37H, 4AH,4C H,4DH,5 AH,5DH
IDIV r32	12-25	35-47	12-25	35-47	Y	Y
IDIV r64	12-41	49-135	12-41	49-135	Y	Y
IMUL r32, r32 (single dest)	1	1	3	3	N	N
IMUL r32 (dual dest)	2	5	3 (4, EDX)	4	N	Y
IMUL r64, r64 (single dest)	2	2	5	5	N	N
IMUL r64 (dual dest)	2	4	5 (6,RDX)	5 (7,RDX)	N	Y
INSERTPS	0.5	1	1	1	N	N
MASKMOVDQU	4	5	4	5	Y	Y
MOVAPD/MOVAPS/MOVDQA/MOVDQU/MOVUPD/MOVUPS xmm, xmm;	0.33 ² /0.5	0.5	0/1	1	N	N
MOVD r32, xmm; MOVQ r64, xmm	1	1	4	4	N	N
MOVD xmm, r32 ; MOVQ xmm, r64	1	1	4	3	N	N
MOVDDUP/MOVHLPs/MOVLHPS/MOVSHDUP/MOVS LDUP	0.5	1	1	1	N	N
MOVDQ2Q/MOVQ/MOVQ2DQ	0.5	0.5	1	1	N	N
MOVSD/MOVSS xmm, xmm;	0.5	0.5	1	1	N	N
MPSADBW	4	5	5	7	Y	Y
MULPD	1	4	4	7	N	N
MULPS; MULSD	1	2	4	5	N	N
MULSS	1	1	4	4	N	N
NEG/NOT r32	0.33	0.5	1	1	N	N
PACKSSDW/WB xmm, xmm; PACKUSWB xmm, xmm	0.5	1	1	1	N	N
PABSB/D/W xmm, xmm	0.5	0.5	1	1	N	N
PADDB/D/W xmm, xmm; PSUBB/D/W xmm, xmm	0.5	0.5	1	1	N	N
PADDQ/PSUBQ/PCMPEQQ xmm, xmm	1	4	2	4	N	Y
PADDSB/W; PADDUSB/W; PSUBSB/W; PSUBUSB/W	0.5	0.5	1	1	N	N
PALIGNR xmm, xmm	0.5	1	1	1	N	N
PAND/PANDN/POR/PXOR xmm, xmm	0.5	0.5	1	1	N	N
PAVGB/W xmm, xmm	0.5	0.5	1	1	N	N
PBLENDW xmm, xmm, imm	0.5	0.5	1	1	N	N
PBLENDVB xmm, xmm	4	4	4	4	Y	Y
PCLMULQDQ xmm, xmm, imm	4	10	6	10	Y	Y
PCMPEQB/D/W xmm, xmm	0.5	0.5	1	1	N	N
PCMPSTRM xmm, xmm, imm	13	21	19(C)/ 26(F) ³	21(C)/ 28(F)	Y	Y
PCMPSTRM xmm, xmm, imm	14	17	15(X)/ 25(F) ¹	17(X)/ 24(F)	Y	Y

Table F-19. Instructions Latency and Throughput Recent Microarchitectures for Intel Atom® Processors (Contd.)

Instruction	Throughput		Latency		MSROM	
	06_5CH, 5FH, 7AH	06_37H, 4AH,4CH ,4DH,5A H,5DH	06_5CH, 5FH, 7AH	06_37H, 4AH,4CH, 4DH,5AH, 5DH	06_5CH ,5FH, 7AH	06_37H, 4AH,4C H,4DH,5 AH,5DH
PCMPGTB/D/W xmm, xmm	0.5	0.5	1	1	N	N
PCMPGTQ/PHMINPOSUW xmm, xmm	2	2	5	5	N	N
PCMPISTRI xmm, xmm, imm	8	17	14(C)/ 21(F) ¹	17(C)/ 24(F)	Y	Y
PCMPISTRM xmm, xmm, imm	7	13	10(X)/ 20(F) ¹	13(X)/ 20(F)	Y	Y
PEXTRB/WD r32, xmm, imm	1	4	4	5	N	Y
PINSRB/WD xmm, r32, imm	1	1	4	3	N	N
PHADD/PHSUBD xmm, xmm	4	6	4	6	Y	Y
PHADDW/PHADDSW xmm, xmm	6	9	6	9	Y	Y
PHSUBW/PHSUBSW xmm, xmm	6	9	6	9	Y	Y
PMADDUBSW/PMADDWD/PMULHRSW/PSADBW xmm, xmm	1	2	4	5	N	N
PMAXSB/W/D xmm, xmm; PMAXUB/W/D xmm, xmm	0.5	0.5	1	1	N	N
PMINSB/W/D xmm, xmm; PMINUB/W/D xmm, xmm	0.5	0.5	1	1	N	N
PMOVMSKB r32, xmm	1	1	4	4	N	N
PMOVSXBW/BD/BQ/WD/WQ/DQ xmm, xmm	0.5	1	1	1	N	N
PMOVZXBW/BD/BQ/WD/WQ/DQ xmm, xmm	0.5	1	1	1	N	N
PMULDQ/PMULUDQ xmm, xmm	1	2	4	5	N	N
PMULHUW/PMULHW/PMULLW xmm, xmm	1	2	4	5	N	N
PMULLD xmm, xmm	2	11	5	11	N	Y
POPCNT r32, r32	1	1	3	3	N	N
POPCNT r64, r64	1	1	3	3	N	N
PSHUFB xmm, xmm	1	5	1	5	N	Y
PSHUFD xmm, mem, imm	0.5	1	1	1	N	N
PSHUFBW; PSHUFLW; PSHUFW	0.5	1	1	1	N	N
PSIGNB/D/W xmm, xmm	0.5	1	1	1	N	N
PSLLDQ/PSRLDQ xmm, imm; SHUFPD/SHUFPS	0.5	1	1	1	N	N
PSLLD/Q/W xmm, xmm	1	2	2	2	N	N
PSRAD/W xmm, imm;	0.5	1	1	1	N	N
PSRAD/W xmm, xmm;	1	2	2	2	N	N
PSRLD/Q/W xmm, imm;	0.5	1	1	1	N	N
PSRLD/Q/W xmm, xmm	1	2	2	2	N	N
PTEST xmm, xmm	1	1	4	4	N	N
PUNPCKHBW/DQ/WD; PUNPCKLBW/DQ/WD	0.5	1	1	1	N	N
PUNPCKHQDQ; PUNPCKLQDQ	0.5	1	1	1	N	N

Table F-19. Instructions Latency and Throughput Recent Microarchitectures for Intel Atom® Processors (Contd.)

Instruction	Throughput		Latency		MSROM	
	06_5CH, 5FH, 7AH	06_37H, 4AH,4CH ,4DH,5A H,5DH	06_5CH, 5FH, 7AH	06_37H, 4AH,4CH, 4DH,5AH, 5DH	06_5CH ,5FH, 7AH	06_37H, 4AH,4C H,4DH,5 AH,5DH
RCPSS/RSQRTPS	6	8	9	9	Y	Y
RCPSS/RSQRTSS	1	1	4	4	N	N
RDTSC	20	30	20	30	Y	Y
ROUNDPD/PS	1	2	4	5	N	N
ROUNDSD/SS	1	1	4	4	N	N
ROL; ROR; SAL; SAR; SHL; SHR (count in CL)	1	1	1 (2 for CL source)	1 (2 for CL source)	N	N
ROL; ROR; SAL; SAR; SHL; SHR (count in imm8)	1	1	1	1	N	N
SAHF	1	1	1	1	N	N
SHLD r32, r32, imm	2	2	2	2	N	N
SHRD r32, r32, imm	2	4	2	4	N	Y
SHLD/SHRD r64, r64, imm	12	10	12	10	Y	Y
SHLD/SHRD r64, r64, CL	14	10	14	10	Y	Y
SHLD/SHRD r32, r32, CL	4	4	4	4	Y	Y
SHUFPD/SHUFPS xmm, xmm, imm	0.5	1	1	1	N	N
SQRTPD	67 26 (GLP)	70	68 30 (GLP)	71	N	Y
SQRTPS	37 14 (GLP)	40	38 18 (GLP)	41	N	Y
SQRTSD	34 14 (GLP)	35	35 18 (GLP)	35	N	Y
SQRTSS	19 8 (GLP)	20	20 12 (GLP)	20	N	Y
TEST r32, r32	0.33	0.5	1	1	N	N
UNPCKHPD; UNPCKHPS; UNPCKLPD, UNPCKLPS	0.5	1	1	1	N	N
XADD r32, r32	2	5	4	5	Y	Y
XCHG r32, r32	2	5	4	5	Y	Y
XCHG r64, r64	2	5	4	5	Y	Y
SHA1MSG1/SHA1MSG2/SHA1NEXTE	1	NA	3	NA	N	NA
SHA1RND4 xmm, xmm, imm	2	NA	5	NA	N	NA
SHA256MSG1/SHA256MSG2	1	NA	3	NA	N	NA
SHA256RND2	4	NA	7	NA	N	NA

NOTES:

1. DIVPD/DIVPS/DIVSD/DIVSS list early-exit value first and common-case value second. Early-exit case applies to a special input value such as QNAN. Common case applies to normal numeric values.
2. Throughput is 0.33 cycles if move elimination is effect, otherwise 0.5 cycle.
3. Latency values are for ECX/EFLAGS/XMM0 dependency: (C/F/X)

Numerics

64-bit mode

- arithmetic, 13-5
- coding guidelines, 13-1
- compiler settings, A-2
- CVTSI2SD instruction, 13-6
- CVTSI2SS instruction, 13-6
- default operand size, 13-1
- legacy instructions, 13-1
- multiplication notes, 13-2
- register usage, 13-1, 13-5
- REX prefix, 13-1
- sign-extension, 13-4
- software prefetch, 13-6

A

- absolute difference of signed numbers, 6-16
- absolute difference of unsigned numbers, 6-15
- absolute value, 6-16
- active power, 17-1
- ADDSUBPD instruction, 7-11
- ADDSUBPS instruction, 7-11, 7-13
- algorithm to avoid changing the rounding mode, 3-68
- alignment
 - arrays, 3-49
 - code, 3-8
 - stack, 3-51
 - structures, 3-49
- Amdahl's law, 11-1
- AoS format, 5-22
- application performance tools, A-1
- arrays
 - aligning, 3-49
- automatic vectorization, 5-16

B

- battery life
 - guidelines for extending, 17-6
 - mobile optimization, 17-1
 - OS APIs, 17-7
 - quality trade-offs, 17-6
- branch prediction
 - choosing types, 3-8
 - code examples, 3-5
 - eliminating branches, 3-4
 - optimizing, 3-4
 - unrolling loops, 3-10

C

- C4-state, 17-4
- cache management
 - blocking techniques, 9-19
 - cache level, 9-3
 - CLFLUSH instruction, 9-9
 - coding guidelines, 8-3, 8-5, 8-10, 8-14, 8-16, 8-17, 8-18, 8-20, 8-21, 8-22, 8-23, 8-25, 9-1, 15-2, 18-3
 - CPUID instruction, 3-3, 9-30
 - function leaf, 3-3
 - optimizing, 9-1
 - simple memory copy, 9-27
 - video decoder, 9-26
 - video encoder, 9-26
 - See also: optimizing cache utilization
- CD/DVD, 17-7
- changing the rounding mode, 3-67

- classes (C/C++), 5-15
- CLFLUSH instruction, 9-9
- clipping to an arbitrary signed range, 6-19
- clipping to an arbitrary unsigned range, 6-21
- coding techniques, 5-12, 11-16
 - 64-bit guidelines, 13-1
 - absolute difference of signed numbers, 6-16
 - absolute difference of unsigned numbers, 6-15
 - absolute value, 6-16
 - clipping to an arbitrary signed range, 6-19
 - clipping to an arbitrary unsigned range, 6-21
 - conserving power, 17-7
 - data in segment, 3-52
 - generating constants, 6-14
 - interleaved pack with saturation, 6-6
 - interleaved pack without saturation, 6-7
 - latency and throughput, D-1
 - methodologies, 5-13
 - non-interleaved unpack, 6-8
 - optimization options, A-2
 - rules, 3-3
 - signed unpack, 6-5
 - simplified clip to arbitrary signed range, 6-20
 - sleep transitions, 17-8
 - suggestions, 3-3
 - tuning hints, 3-3
 - unsigned unpack, 6-5
 - See also: floating-point code
- coherent requests, 9-7
- command-line options
 - inline expansion of library functions, A-3
 - vectorizer switch, A-3
- comparing register values, 3-25, 3-26
- compatibility mode, 13-1
- compiler intrinsics
 - _mm_load, 9-26
 - _mm_prefetch, 9-26
 - _mm_stream, 9-26
- compilers
 - documentation, 1-4
 - general recommendations, 3-2
 - plug-ins, A-2
 - supported alignment options, 5-19
 - See also: Intel C++ Compiler & Intel Fortran Compiler
- computation
 - intensive code, 5-12
- converting 64-bit to 128-bit SIMD integers, 6-33
- converting code to MMX technology, 5-10
- CPUID instruction
 - cache parameters, 9-30
 - function leaf, 9-30
 - function leaf 4, 3-3
 - Intel compilers, 3-2
 - MMX support, 5-2
 - SSE support, 5-2
 - SSE2 support, 5-2
 - SSE3 support, 5-3
 - SSSE3 support, 5-3, 5-4
 - strategy for use, 3-2
- C-states, 17-1, 17-3
- CVTSI2SD instruction, 13-6
- CVTSI2SS instruction, 13-6
- CVTTPS2PI instruction, 7-10
- CVTTSS2SI instruction, 7-10

D

- data

INDEX

- access pattern of array, 3-50
- aligning arrays, 3-49
- aligning structures, 3-49
- alignment, 5-17
- arrangement, 7-2
- code segment and, 3-52
- deswizzling, 7-7
- swizzling, 7-5
- swizzling using intrinsics, 7-6

deeper sleep, 17-4

denormals-are-zero (DAZ), 7-10

deterministic cache parameters

- cache sharing, 9-30, 9-31
- multicore, 9-32
- overview, 9-30
- prefetch stride, 9-32

domain decomposition, 11-4

Dynamic execution, E-40

E

- eliminating branches, 3-6, 17-14

EMMS instruction, 6-2, 6-3

- guidelines for using, 6-2

Enhanced Intel SpeedStep Technology

- description of, 17-8
- multicore processors, 17-10
- usage scenario, 17-1

extract word instruction, 6-9

F

fencing operations, 9-5

- LFENCE instruction, 9-8
- MFENCE instruction, 9-9

FIST instruction, 3-67

FLDCW instruction, 3-67

floating-point code

- arithmetic precision options, A-3
- data arrangement, 7-2
- data deswizzling, 7-7
- data swizzling using intrinsics, 7-6
- guidelines for optimizing, 3-64
- horizontal ADD, 7-8
- improving parallelism, 3-69
- memory access stall information, 3-47
- operations, integer operands, 3-69
- optimizing, 3-64
- planning considerations, 7-1, 8-1
- rules and suggestions, 7-1, 8-1
- scalar code, 7-2
- transcendental functions, 3-69
- unrolling loops, 3-10
- vertical versus horizontal computation, 7-3

See also: coding techniques

flush-to-zero (FTZ), 7-10

front end

- branching ratios, B-65
- characterizing mispredictions, B-66
- loop unrolling, 11-21
- optimization, 3-4

functional decomposition, 11-4

FXCH instruction, 3-69, 7-2

G

- generating constants, 6-14

GetActivePwrScheme, 17-7

GetSystemPowerStatus, 17-7

H

HADDPD instruction, 7-11

HADDPD instruction, 7-11, 7-14

hardware multithreading

- support for, 3-3

hardware prefetch

- cache blocking techniques, 9-23
- latency reduction, 9-13
- memory optimization, 9-12
- operation, 9-12

horizontal computations, 7-8

hotspots

- definition of, 5-12
- identifying, 5-12
- VTune analyzer, 5-12

HSUBPD instruction, 7-11

HSUBPS instruction, 7-11, 7-14

Hyper-Threading Technology

- avoid excessive software prefetches, 11-17
- bus optimization, 11-9
- cache blocking technique, 11-19
- conserve bus command bandwidth, 11-17
- eliminate 64-K-aliased data accesses, 11-21
- excessive loop unrolling, 11-21
- front-end optimization, 11-21
- full write transactions, 11-18
- functional decomposition, 11-4
- improve effective latency of cache misses, 11-18
- memory optimization, 11-19
- minimize data sharing between physical processors, 11-19
- multitasking environment, 11-2
- optimization, 11-1
- optimization guidelines, 11-8
- optimization with spin-locks, 11-13
- overview, 2-34
- parallel programming models, 11-4
- pipeline, 2-36
- placement of shared synchronization variable, 11-15
- prevent false-sharing of data, 11-14
- processor resources, 2-35
- shared execution resources, 11-25
- shared-memory optimization, 11-19
- synchronization for longer periods, 11-13
- synchronization for short periods, 11-11
- system bus optimization, 11-16
- thread sync practices, 11-8
- thread synchronization, 11-10
- tools for creating multithreaded applications, 11-7

I

IA32_PERFVSELx MSR, B-64

increasing bandwidth

- memory fills, 6-29
- video fills, 6-29

Indefinite

- description of, 2-42, 2-43

indirect branch, 3-8

inline assembly, 6-3

inline expansion library functions option, A-3

inlined-asm, 5-14

insert word instruction, 6-10

instruction latency/throughput

- overview, D-1

instruction scheduling, 3-52

Intel 64 and IA-32 processors, 2-1

Intel Advanced Digital Media Boost, E-27

Intel Advanced Memory Access, E-34

Intel Advanced Smart Cache, E-26, E-38

Intel Core Duo processors

- 128-bit integers, 6-33
- packed FP performance, 7-14
- performance events, B-59
- SIMD support, 5-1

- special programming models, 11-4
- static prediction, 3-6
- Intel Core microarchitecture, E-26
 - advanced smart cache, E-38
 - branch prediction unit, E-29
 - event ratios, B-64
 - execution core, E-31
 - execution units, E-32
 - issue ports, E-32
 - front end, E-28
 - instruction decode, E-31
 - instruction fetch unit, E-29
 - instruction queue, E-30
 - advanced memory access, E-34
 - micro-fusion, E-31
 - pipeline overview, E-9, E-27
 - special programming models, 11-4
 - stack pointer tracker, E-31
 - static prediction, 3-7
- Intel Core Solo processors
 - 128-bit SIMD integers, 6-33
 - performance events, B-59
 - SIMD support, 5-1
 - static prediction, 3-6
- Intel C++ Compiler, 3-1
 - 64-bit mode settings, A-2
 - description, A-1
 - IA-32 settings, A-2
 - multithreading support, A-3
 - OpenMP, A-3
 - optimization settings, A-2
 - related Information, 1-4
- Intel Debugger
 - description, A-1
- Intel developer link, 1-4
- Intel Enhanced Deeper Sleep
 - C-state numbers, 17-3
 - enabling, 17-9
 - multiple-cores, 17-12
- Intel Fortran Compiler
 - description, A-1
 - multithreading support, A-3
 - OpenMP, A-3
 - optimization settings, A-2
 - related information, 1-4
- Intel Integrated Performance Primitives
 - for Linux, A-5
 - for Windows, A-5
- Intel Math Kernel Library for Linux, A-5
- Intel Math Kernel Library for Windows, A-5
- Intel Mobile Platform SDK, 17-7
- Intel NetBurst microarchitecture
 - introduction, 2-34, E-8
- Intel Performance Libraries
 - benefits, A-5
 - optimizations, A-5
- Intel performance libraries
 - description, A-1
- Intel Performance Tools, 3-1
- Intel Smart Memory Access, E-27
- Intel Thread Checker
 - example output, A-5, A-7, A-8
- Intel Threading Tools, A-7
- Intel VTune Amplifier
 - related information, 1-4
- Intel VTune Performance Analyzer
 - code coach, 5-12
 - coverage, 3-2
- Intel Wide Dynamic Execution, E-26, E-27, E-40
- interleaved pack with saturation, 6-6
- interleaved pack without saturation, 6-7
- interprocedural optimization, A-3

- introduction
 - chapter summaries, 1-1
 - optimization features, 2-1
 - processors covered, 1-1
 - references, 1-4
- IPO. See interprocedural optimization

L

- large load stalls, 3-47
- latency, 9-2, 9-14
- legacy mode, 13-1
- LFENCE instruction, 9-8
- links to web data, 1-4
- load instructions and prefetch, 9-4
- loading-storing to-from same DRAM page, 6-29
- loop
 - blocking, 5-24
 - unrolling, 9-17, A-3

M

- MASKMOVDQU instruction, 9-5
- memory bank conflicts, 9-2
- memory optimizations
 - loading-storing to-from same DRAM page, 6-29
 - overview, 6-27
 - partial memory accesses, 6-28, 6-30
 - performance, 5-20
 - reference instructions, 3-24
 - using aligned stores, 6-30
 - using prefetch, 9-12
- MFENCE instruction, 9-9
- misaligned data access, 5-17
- misalignment in the FIR filter, 5-18
- mobile computing
 - ACPI standard, 17-1, 17-3
 - active power, 17-1
 - battery life, 17-1, 17-6, 17-7
 - C4-state, 17-4
 - CD/DVD, WLAN, WiFi, 17-7
 - C-states, 17-1, 17-3
 - deep sleep transitions, 17-8
 - deeper sleep, 17-4, 17-9
 - Intel Mobile Platform SDK, 17-7
 - OS APIs, 17-7
 - OS changes processor frequency, 17-2
 - OS synchronization APIs, 17-7
 - overview, 17-1, F-1
 - performance options, 17-6
 - platform optimizations, 17-7
 - P-states, 17-1
 - Speedstep technology, 17-8
 - spin-loops, 17-7
 - state transitions, 17-2
 - static power, 17-1
 - WM_POWERBROADCAST message, 17-8
- MOVAPD instruction, 7-2
- MOVAPS instruction, 7-2
- MOVDDUP instruction, 7-11
- move byte mask to integer, 6-12
- MOVHPS instruction, 7-8
- MOVLHPS instruction, 7-8
- MOVNTDQ instruction, 9-5
- MOVNTI instruction, 9-5
- MOVNTPD instruction, 9-5
- MOVNTPS instruction, 9-5
- MOVNTQ instruction, 9-5
- MOVQ instruction, 6-29
- MOVSHDUP instruction, 7-11, 7-13
- MOVSLDUP instruction, 7-11, 7-13
- MOVUPD instruction, 7-2

INDEX

MOVUPS instruction, 7-2
multicore processors
 architecture, 2-1
 C-state considerations, 17-11
 energy considerations, 17-10
 SpeedStep technology, 17-10
 thread migration, 17-10
multiprocessor systems
 dual-core processors, 11-1
 HT Technology, 11-1
 optimization techniques, 11-1
 See also: multithreading & Hyper-Threading Technology
multithreading
 Amdahl's law, 11-1
 application tools, 11-7
 bus optimization, 11-9
 compiler support, A-3
 dual-core technology, 3-3
 environment description, 11-1
 guidelines, 11-8
 hardware support, 3-3
 HT technology, 3-3
 Intel Core microarchitecture, 11-4
 parallel & sequential tasks, 11-1
 programming models, 11-3
 shared execution resources, 11-25
 specialized models, 11-4
 thread sync practices, 11-8
 See Hyper-Threading Technology

N

Newton-Raphson iteration, 7-1
non-coherent requests, 9-7
non-interleaved unpack, 6-8
non-temporal stores, 9-6, 9-25
NOP, 3-27

O

OpenMP compiler directives, 11-7, A-3
optimization
 branch prediction, 3-4
 branch type selection, 3-8
 eliminating branches, 3-4
 features, 2-1
 general techniques, 3-1
 static prediction, 3-6
 unrolling loops, 3-10
optimizing cache utilization
 cache management, 9-26
 examples, 9-8
 non-temporal store instructions, 9-5, 9-8
 prefetch and load, 9-5
 prefetch instructions, 9-3
 prefetching, 9-3
 SFENCE instruction, 9-8, 9-9
 streaming, non-temporal stores, 9-5
 See also: cache management
OS APIs, 17-7

P

pack instructions, 6-6
packed average byte or word), 6-22
packed multiply high unsigned, 6-21
packed shuffle word, 6-12
packed signed integer word maximum, 6-21
packed sum of absolute differences, 6-22
parallelism, 5-12, 11-4
partial memory accesses, 6-28
PAUSE instruction, 11-8

PAVGB instruction, 6-22
PAVGW instruction, 6-22
PeekMessage(), 17-7
Pentium 4 processors
 static prediction, 3-6
Pentium M processors
 static prediction, 3-6
performance models
 Amdahl's law, 11-1
 multithreading, 11-1
 parallelism, 11-1
 usage, 11-1
performance monitoring events
 analysis techniques, B-60
 Bus_Not_In_Use, B-60
 Bus_Snoops, B-60
 DCU_Snoop_to_Share, B-60
 drill-down techniques, B-60
 event ratios, B-64
 Intel Core Duo processors, B-59
 Intel Core Solo processors, B-59
 Intel Netburst architecture, B-1
 Intel Xeon processors, B-1
 L1_Pref_Req, B-60
 L2_No_Request_Cycles, B-60
 L2_Reject_Cycles, B-60
 Pentium 4 processor, B-1
 performance counter, B-59
 ratio interpretation, B-59
 See also: clock ticks
 Serial_Execution_Cycles, B-60
 Unhalted_Core_Cycles, B-60
 Unhalted_Ref_Cycles, B-60
performance tools, 3-1
PEXTRW instruction, 6-9
PGO. See profile-guided optimization
PINSRW instruction, 6-10
PMINSW instruction, 6-21
PMINUB instruction, 6-21
PMOVMASKB instruction, 6-12
PMULHUW instruction, 6-21
predictable memory access patterns, 9-3
prefetch
 64-bit mode, 13-6
 coding guidelines, 9-1
 concatenation, 9-17
 deterministic cache parameters, 9-30
 hardware mechanism, 9-2
 characteristics, 9-12
 latency, 9-13
 how instructions designed, 9-3
 innermost loops, 9-3
 instruction considerations
 cache block techniques, 9-19
 checklist, 9-15
 concatenation, 9-16
 hint mechanism, 9-2
 minimizing number, 9-17
 scheduling distance, 9-16
 single-pass execution, 9-1, 9-24
 spread with computations, 9-19
 strip-mining, 9-21
 summary of, 9-2
 instruction variants, 9-3
 latency hiding/reduction, 9-14
 load instructions, 9-4
 memory access patterns, 9-3
 memory optimization with, 9-12
 minimizing number of, 9-17
 scheduling distance, 9-2, 9-16
 software data, 9-2
 spreading, 9-19

- when introduced, 9-1
- PREFETCHNTA instruction, 9-21
 - usage guideline, 9-2
- PREFETCHTO instruction, 9-21
 - usage guideline, 9-2
- producer-consumer model, 11-4
- profile-guided optimization, A-4
- PSADBW instruction, 6-22
- PSHUF instruction, 6-12
- P-states, 17-1

Q

- Qparallel, 11-8

R

- ratios, B-64
 - branching and front end, B-65
- references, 1-4
- releases of, 2-39

S

- sampling
 - event-based, A-6
- scheduling distance (PSD), 9-16
- Self-modifying code, 3-52
- SFENCE instruction, 9-8
- SHUFPS instruction, 7-3
- signed unpack, 6-5
- SIMD
 - auto-vectorization, 5-16
 - cache instructions, 9-1
 - classes, 5-15
 - coding techniques, 5-12
 - data alignment for 128-bits, 5-19
 - data alignment for MMX, 5-18
 - data and stack alignment, 5-17
 - example computation, 2-37
 - history, 2-37
 - identifying hotspots, 5-12
 - instruction selection, 5-26
 - loop blocking, 5-24
 - memory utilization, 5-20
 - MMX technology support, 5-2
 - padding to align data, 5-17
 - parallelism, 5-12
 - SSE support, 5-2
 - SSE2 support, 5-2
 - SSE3 support, 5-3
 - SSE3 support, 5-3, 5-4
 - stack alignment for 128-bits, 5-18
 - strip-mining, 5-23
 - using arrays, 5-17
 - vectorization, 5-12
 - VTune capabilities, 5-12
- SIMD floating-point instructions
 - data arrangement, 7-2
 - data deswizzling, 7-7
 - data swizzling, 7-5
 - different microarchitectures, 7-11
 - general rules, 7-1
 - horizontal ADD, 7-8
 - Intel Core Duo processors, 7-14
 - Intel Core Solo processors, 7-14
 - planning considerations, 7-1, 8-1
 - reciprocal instructions, 7-1
 - scalar code, 7-2
 - SSE3 complex math, 7-12
 - SSE3 FP programming, 7-11
 - using

- ADDSUBPS, 7-13
- CVTTSS2PI, 7-10
- CVTTSS2SI, 7-10
- FXCH, 7-2
- HADDPS, 7-14
- HSUBPS, 7-14
- MOVAPD, 7-2
- MOVAPS, 7-2
- MOVHLPS, 7-8
- MOVLHPS, 7-8
- MOVSHDUP, 7-13
- MOVSLDUP, 7-13
- MOVUPD, 7-2
- MOVUPS, 7-2
- SHUFPS, 7-3

- vertical vs horizontal computation, 7-3
- with x87 FP instructions, 7-2

- SIMD technology, 2-39

- SIMD-integer instructions

- 64-bits to 128-bits, 6-33
- data alignment, 6-3
- data movement techniques, 6-5
- extract word, 6-9
- integer intensive, 6-1
- memory optimizations, 6-27
- move byte mask to integer, 6-12
- optimization by architecture, 6-33
- packed average byte or word, 6-22
- packed multiply high unsigned, 6-21
- packed shuffle word, 6-12
- packed signed integer word maximum, 6-21
- packed sum of absolute differences, 6-22
- rules, 6-1
- signed unpack, 6-5
- unsigned unpack, 6-5
- using

- EMMS, 6-2
- MOVDQ, 6-29
- MOVQ2DQ, 6-14
- PABSW, 6-16
- PACKSSDQ, 6-6
- PADDQ, 6-23
- PALIGNR, 6-4
- PAVGB, 6-22
- PAVGW, 6-22
- PEXTRW, 6-9
- PINSRW, 6-10
- PMADDWD, 6-22
- PMAXSW, 6-21
- PMAXUB, 6-21
- PMINSW, 6-21
- PMINUB, 6-21
- PMOVMASK, 6-12
- PMULHUW, 6-21
- PMULHW, 6-21
- PMULUDQ, 6-21
- PSADBW, 6-22
- PSHUF, 6-12
- PSHUFB, 6-17, 6-18
- PSHUFLW, 6-13
- PSLLDQ, 6-23
- PSRLDQ, 6-23
- PSUBQ, 6-23
- PUNPCHQDQ, 6-14
- PUNPCKLQDQ, 6-14

- simplified 3D geometry pipeline, 9-14

- simplified clipping to an arbitrary signed range, 6-20

- single vs multi-pass execution, 9-24

- sleep transitions, 17-8

- SoA format, 5-22

- software write-combining, 9-25

- spin-loops, 17-7

INDEX

- related information, 1-4
- SSE, 2-39
- SSE2, 2-39
- SSE3, 2-40
- SSSE3, 2-40, 2-41
- stack
 - alignment 128-bit SIMD, 5-18
 - alignment stack, 3-51
 - dynamic alignment, 3-51
- state transitions, 17-2
- static power, 17-1
- static prediction, 3-6
- streaming stores, 9-5
 - coherent requests, 9-7
 - improving performance, 9-6
 - non-coherent requests, 9-7
- strip-mining, 5-23, 5-24, 9-21, 9-22
 - prefetch considerations, 9-23
- structures
 - aligning, 3-49
- system bus optimization, 11-16

T

- time-consuming innermost loops, 9-3
- transaction lookaside buffer, 9-27
- transcendental functions, 3-69

U

- unpack instructions, 6-8
- unrolling loops
 - benefits of, 3-10
 - code examples, 3-11
- unsigned unpack, 6-5
- using MMX code for copy, shuffling, 7-8

V

- vector class library, 5-16
- vectorized code
 - auto generation, A-4
 - automatic vectorization, 5-16
 - high-level examples, A-4
 - parallelism, 5-12
 - SIMD architecture, 5-12
 - switch options, A-3
- vertical vs horizontal computation, 7-3

W

- WaitForSingleObject(), 17-7
- WaitMessage(), 17-7
- weakly ordered stores, 9-5
- WiFi, 17-7
- WLAN, 17-7
- write-combining
 - buffer, 9-26
 - memory, 9-26
 - semantics, 9-6

X

- XCHG EAX,EAX, support for, 3-27
- XFEATURE_ENALBED_MASK, 5-5
- XRSTOR, 5-5
- XSAVE, 5-5, 5-8, 5-9

Z

- , A-1

CHAPTER 1 INTRODUCTION

1.1	TUNING YOUR APPLICATION	1-1
1.2	ABOUT THIS MANUAL	1-1
1.3	RELATED INFORMATION	1-4

CHAPTER 2 INTEL® 64 AND IA-32 PROCESSOR ARCHITECTURES

2.1	SAPPHIRE RAPIDS ARCHITECTURE	2-1
2.1.1	Intel® 4th generation Intel® Xeon® Scalable Family of Processors	2-1
2.2	ALDER LAKE PERFORMANCE HYBRID ARCHITECTURE	2-2
2.2.1	12th Generation Intel® Core™ Processors Supporting Performance Hybrid Architecture	2-2
2.2.2	Hybrid Scheduling	2-2
2.2.2.1	Intel® Thread Director	2-2
2.2.2.2	Scheduling with Intel Hyper-Threading Technology Enabled on Processors Supporting x86 Hybrid Architecture	2-6
2.2.2.3	Scheduling with a Multi-E-Core Module	2-6
2.2.2.4	Scheduling Background Threads on x86 Hybrid Architecture	2-6
2.2.3	Recommendations for Application Developers	2-6
2.3	GOLDEN COVE MICROARCHITECTURE	2-7
2.3.1	Golden Cove Microarchitecture Overview	2-8
2.3.1.1	The Front End	2-9
2.3.1.2	The Out-of-Order and Execution Engines	2-9
2.3.1.3	Cache Subsystem and Memory Subsystem	2-12
2.3.1.4	Avoiding Destination False Dependency	2-12
2.4	ICE LAKE CLIENT MICROARCHITECTURE	2-14
2.4.1	Ice Lake Client Microarchitecture Overview	2-14
2.4.1.1	The Front End	2-15
2.4.1.2	The Out of Order and Execution Engines	2-15
2.4.1.3	Cache and Memory Subsystem	2-17
	Paired Stores	2-18
2.4.1.4	New Instructions	2-19
2.4.1.5	Ice Lake Client Microarchitecture Power Management	2-20
2.5	SKYLAKE SERVER MICROARCHITECTURE	2-21
2.5.1	Skylake Server Microarchitecture Cache	2-22
2.5.1.1	Larger Mid-Level Cache	2-22
2.5.1.2	Non-Inclusive Last Level Cache	2-22
2.5.1.3	Skylake Server Microarchitecture Cache Recommendations	2-23
2.5.2	Non-Temporal Stores on Skylake Server Microarchitecture	2-24
2.5.3	Skylake Server Power Management	2-25
2.6	SKYLAKE CLIENT MICROARCHITECTURE	2-28
2.6.1	The Front End	2-29
2.6.2	The Out-of-Order Execution Engine	2-29
2.6.3	Cache and Memory Subsystem	2-31
2.6.4	Pause Latency in Skylake Client Microarchitecture	2-32
2.7	INTEL® HYPER-THREADING TECHNOLOGY	2-34
2.7.1	Processor Resources and HT Technology	2-35
2.7.1.1	Replicated Resources	2-36
2.7.1.2	Partitioned Resources	2-36
2.7.1.3	Shared Resources	2-36
2.7.2	Microarchitecture Pipeline and HT Technology	2-36
2.7.3	Execution Core	2-37
2.7.4	Retirement	2-37
2.8	SIMD TECHNOLOGY	2-37
2.9	SUMMARY OF SIMD TECHNOLOGIES AND APPLICATION LEVEL EXTENSIONS	2-39
2.9.1	MMX™ Technology	2-39
2.9.2	Streaming SIMD Extensions	2-39
2.9.3	Streaming SIMD Extensions 2	2-39
2.9.4	Streaming SIMD Extensions 3	2-40
2.9.5	Supplemental Streaming SIMD Extensions 3	2-40
2.9.6	SSE4.1	2-40
2.9.7	SSE4.2	2-41
2.9.8	AESNI and PCLMULQDQ	2-41

2.9.9	Intel® Advanced Vector Extensions	2-41
2.9.10	Half-Precision Floating-Point Conversion (F16C)	2-42
2.9.11	RDRAND	2-42
2.9.12	Fused-Multiply-ADD (FMA) Extensions	2-42
2.9.13	Intel AVX2	2-42
2.9.14	General-Purpose Bit-Processing Instructions	2-42
2.9.15	Intel® Transactional Synchronization Extensions	2-42
2.9.16	RDSEED	2-43
2.9.17	ADCX and ADOX Instructions	2-43

CHAPTER 3

GENERAL OPTIMIZATION GUIDELINES

3.1	PERFORMANCE TOOLS	3-1
3.1.1	Intel® C++ and Fortran Compilers	3-1
3.1.2	General Compiler Recommendations	3-2
3.1.3	VTune™ Performance Analyzer	3-2
3.2	PROCESSOR PERSPECTIVES	3-2
3.2.1	CPUID Dispatch Strategy and Compatible Code Strategy	3-2
3.2.2	Transparent Cache-Parameter Strategy	3-3
3.2.3	Threading Strategy and Hardware Multithreading Support	3-3
3.3	CODING RULES, SUGGESTIONS AND TUNING HINTS	3-3
3.4	OPTIMIZING THE FRONT END	3-4
3.4.1	Branch Prediction Optimization	3-4
3.4.1.1	Eliminating Branches	3-4
3.4.1.2	Static Prediction	3-6
3.4.1.3	Inlining, Calls and Returns	3-7
3.4.1.4	Code Alignment	3-8
3.4.1.5	Branch Type Selection	3-8
3.4.1.6	Loop Unrolling	3-10
3.4.2	Fetch and Decode Optimization	3-11
3.4.2.1	Optimizing for Micro-fusion	3-11
3.4.2.2	Optimizing for Macrofusion	3-12
3.4.2.3	Length-Changing Prefixes (LCP)	3-16
3.4.2.4	Optimizing the Loop Stream Detector (LSD)	3-17
3.4.2.5	Optimization for Decoded ICache	3-18
3.4.2.6	Other Decoding Guidelines	3-19
3.5	OPTIMIZING THE EXECUTION CORE	3-19
3.5.1	Instruction Selection	3-20
3.5.1.1	Integer Divide	3-20
3.5.1.2	Using LEA	3-21
3.5.1.3	ADC and SBB in Sandy Bridge Microarchitecture	3-22
3.5.1.4	Bitwise Rotation	3-23
3.5.1.5	Variable Bit Count Rotation and Shift	3-24
3.5.1.6	Address Calculations	3-24
3.5.1.7	Clearing Registers and Dependency Breaking Idioms	3-25
3.5.1.8	Compares	3-26
3.5.1.9	Using NOPs	3-27
3.5.1.10	Mixing SIMD Data Types	3-28
3.5.1.11	Spill Scheduling	3-28
3.5.1.12	Zero-Latency MOV Instructions	3-28
3.5.2	Avoiding Stalls in Execution Core	3-30
3.5.2.1	Writeback Bus Conflicts	3-30
3.5.2.2	Bypass between Execution Domains	3-31
3.5.2.3	Partial Register Stalls	3-31
3.5.2.4	Partial XMM Register Stalls	3-32
3.5.2.5	Partial Flag Register Stalls	3-33
3.5.2.6	Floating-Point/SIMD Operands	3-34
3.5.3	Vectorization	3-34
3.5.4	Optimization of Partially Vectorizable Code	3-35
3.5.4.1	Alternate Packing Techniques	3-37
3.5.4.2	Simplifying Result Passing	3-37
3.5.4.3	Stack Optimization	3-38
3.5.4.4	Tuning Considerations	3-38
3.6	OPTIMIZING MEMORY ACCESSES	3-40

3.6.1	Load and Store Execution Bandwidth	3-40
3.6.1.1	Making Use of Load Bandwidth in Sandy Bridge Microarchitecture	3-40
3.6.1.2	L1D Cache Latency in Sandy Bridge Microarchitecture	3-41
3.6.1.3	Handling L1D Cache Bank Conflict	3-42
3.6.2	Minimize Register Spills	3-43
3.6.3	Enhance Speculative Execution and Memory Disambiguation	3-44
3.6.4	Store Forwarding	3-45
3.6.4.1	Store-to-Load-Forwarding Restriction on Size and Alignment	3-46
3.6.4.2	Store-forwarding Restriction on Data Availability	3-48
3.6.5	Data Layout Optimizations	3-49
3.6.6	Stack Alignment	3-51
3.6.7	Capacity Limits and Aliasing in Caches	3-52
3.6.8	Mixing Code and Data	3-52
3.6.8.1	Self-modifying Code	3-52
3.6.8.2	Position Independent Code	3-53
3.6.9	Write Combining	3-53
3.6.10	Locality Enhancement	3-54
3.6.11	Non-Temporal Store Bus Traffic	3-55
3.7	PREFETCHING	3-56
3.7.1	Hardware Instruction Fetching and Software Prefetching	3-56
3.7.2	Hardware Prefetching for First-Level Data Cache	3-56
3.7.3	Hardware Prefetching for Second-Level Cache	3-58
3.7.4	Cacheability Instructions	3-59
3.7.5	REP Prefix and Data Movement	3-59
3.7.6	Enhanced REP MOVSB and STOSB Operation	3-61
3.7.6.1	Fast Short REP MOVSB	3-61
3.7.6.2	Memcpy Considerations	3-61
3.7.6.3	Memmove Considerations	3-63
3.7.6.4	Memset Considerations	3-63
3.8	REP STRING OPERATIONS	3-63
3.8.1	Fast Zero Length REP MOVSB	3-64
3.8.2	Fast Short REP STOSB	3-64
3.8.3	Fast Short REP CMPSB and SCASB	3-64
3.9	FLOATING-POINT CONSIDERATIONS	3-64
3.9.1	Guidelines for Optimizing Floating-point Code	3-64
3.9.2	Floating-point Modes and Exceptions	3-65
3.9.2.1	Floating-point Exceptions	3-65
3.9.2.2	Dealing with floating-point exceptions in x87 FPU code	3-66
3.9.2.3	Floating-point Exceptions in SSE/SSE2/SSE3 Code	3-66
3.9.3	Floating-point Modes	3-66
3.9.3.1	Rounding Mode	3-67
3.9.3.2	Precision	3-68
3.9.4	x87 vs. Scalar SIMD Floating-point Trade-offs	3-69
3.9.4.1	Scalar SSE/SSE2	3-69
3.9.4.2	Transcendental Functions	3-69
3.10	MAXIMIZING PCIE PERFORMANCE	3-70
3.10.1	Optimizing PCIe Performance for Accesses Toward Coherent Memory and Toward MMIO Regions (P2P)	3-70
3.11	SCALABILITY WITH CONTENTED LINE ACCESS IN INTEL® 4TH GENERATION INTEL® XEON® SCALABLE PROCESSORS	3-71
3.11.1	Why it Happens	3-71
3.11.2	How to Detect it	3-71
3.11.3	How to Fix it	3-72
3.11.4	Case Study: SysBench/MariaDB Metric CHA % Cycles Fast Asserted	3-73
3.11.5	Instruction Sequence Slowdowns	3-74
3.11.5.1	Why it Happens	3-74
3.11.5.2	How to Detect it	3-74
3.11.5.3	How to Fix it	3-74
3.11.6	Misprediction for Branches >2GB	3-75
3.11.6.1	Why it Happens	3-75
3.11.6.2	How to Detect it	3-75
3.11.6.3	How to Fix it	3-76
3.12	OPTIMIZING COMMUNICATION WITH PCI DEVICES ON INTEL® 4TH GENERATION INTEL® XEON® SCALABLE PROCESSORS	3-77
3.12.1	Signaling Devices with Direct Move	3-77
3.12.1.1	MOVDIR64B – Additional considerations	3-77

3.12.1.2	Streaming Data	3-78
3.13	SYNCHRONIZATION	3-78
3.13.1	User-Level Monitor, User-Level MWAIT, and TPAUSE	3-78
3.13.1.1	Checking for User-Level Monitor, MWAIT, and TPAUSE support	3-78
3.13.1.2	User-Level Monitor, User-Level MWAIT, and TPAUSE Operations	3-78
3.13.1.3	Recommended usage	3-79

CHAPTER 4

INTEL ATOM® PROCESSOR ARCHITECTURES

4.1	GRACEMONT MICROARCHITECTURE	4-1
4.1.1	Gracemont Microarchitecture Overview	4-1
4.1.2	Predict and Fetch	4-2
4.1.3	Dynamic Load Balancing	4-4
4.1.4	Decode and the On-Demand Instruction Length Decoder	4-4
4.1.5	Allocation and Retirement	4-5
4.1.6	The Out-of-Order and Execution Engines	4-5
4.1.7	Cache and Memory Subsystem	4-7
4.1.8	Intel® AVX and Intel® AVX2 Instruction Support	4-8
4.1.8.1	256-bit Permute Operations	4-8
4.1.8.2	256-bit Broadcast with 128-bit Memory Operand	4-8
4.1.8.3	256-bit Insertion, Up-Conversion Instructions with 128-bit Memory Operand	4-8
4.1.8.4	256-bit Variable Blend Instructions	4-9
4.1.8.5	256-bit Vector TEST Instructions	4-9
4.1.8.6	GATHER Instructions	4-9
4.1.8.7	Masked Load and Store Instructions	4-9
4.1.8.8	ADX Instructions	4-9
4.1.8.9	BMI1, BMI2, and LZCNT Instructions	4-10
4.2	TREMONT MICROARCHITECTURE	4-10
4.2.1	Tremont Microarchitecture Overview	4-10
4.2.2	The Front End	4-11
4.2.3	The Out of Order and Execution Engines	4-12
4.2.4	Cache and Memory Subsystem	4-13
4.2.5	New Instructions	4-13
4.2.6	Tremont Microarchitecture Power Management	4-14

CHAPTER 5

CODING FOR SIMD ARCHITECTURES

5.1	CHECKING FOR PROCESSOR SUPPORT OF SIMD TECHNOLOGIES	5-1
5.1.1	Checking for MMX Technology Support	5-2
5.1.2	Checking for Streaming SIMD Extensions Support	5-2
5.1.3	Checking for Streaming SIMD Extensions 2 Support	5-2
5.1.4	Checking for Streaming SIMD Extensions 3 Support	5-3
5.1.5	Checking for Supplemental Streaming SIMD Extensions 3 Support	5-3
5.1.6	Checking for SSE4.1 Support	5-4
5.1.7	Checking for SSE4.2 Support	5-4
5.1.8	DetectiON of PCLMULQDQ and AESNI Instructions	5-4
5.1.9	Detection of AVX Instructions	5-5
5.1.10	Detection of VEX-Encoded AES and VPCLMULQDQ	5-7
5.1.11	Detection of F16C Instructions	5-7
5.1.12	Detection of FMA	5-8
5.1.13	Detection of AVX2	5-9
5.2	CONSIDERATIONS FOR CODE CONVERSION TO SIMD PROGRAMMING	5-10
5.2.1	Identifying Hot Spots	5-12
5.2.2	Determine If Code Benefits by Conversion to SIMD Execution	5-12
5.3	CODING TECHNIQUES	5-12
5.3.1	Coding Methodologies	5-13
5.3.1.1	Assembly	5-14
5.3.1.2	Intrinsics	5-14
5.3.1.3	Classes	5-15
5.3.1.4	Automatic Vectorization	5-16
5.4	STACK AND DATA ALIGNMENT	5-17
5.4.1	Alignment and Contiguity of Data Access Patterns	5-17

5.4.1.1	Using Padding to Align Data	5-17
5.4.1.2	Using Arrays to Make Data Contiguous.....	5-17
5.4.2	Stack Alignment For 128-bit SIMD Technologies.....	5-18
5.4.3	Data Alignment for MMX Technology	5-18
5.4.4	Data Alignment for 128-bit data.....	5-19
5.4.4.1	Compiler-Supported Alignment	5-19
5.5	IMPROVING MEMORY UTILIZATION	5-20
5.5.1	Data Structure Layout	5-20
5.5.2	Strip-Mining	5-23
5.5.3	Loop Blocking.....	5-24
5.6	INSTRUCTION SELECTION	5-26
5.7	TUNING THE FINAL APPLICATION.....	5-27

CHAPTER 6

OPTIMIZING FOR SIMD INTEGER APPLICATIONS

6.1	GENERAL RULES ON SIMD INTEGER CODE	6-1
6.2	USING SIMD INTEGER WITH X87 FLOATING-POINT.....	6-2
6.2.1	Using the EMMS Instruction	6-2
6.2.2	Guidelines for Using EMMS Instruction	6-2
6.3	DATA ALIGNMENT	6-3
6.4	DATA MOVEMENT CODING TECHNIQUES	6-5
6.4.1	Unsigned Unpack	6-5
6.4.2	Signed Unpack.....	6-5
6.4.3	Interleaved Pack with Saturation	6-6
6.4.4	Interleaved Pack without Saturation.....	6-7
6.4.5	Non-Interleaved Unpack.....	6-8
6.4.6	Extract Data Element	6-9
6.4.7	Insert Data Element.....	6-10
6.4.8	Non-Unit Stride Data Movement.....	6-11
6.4.9	Move Byte Mask to Integer.....	6-12
6.4.10	Packed Shuffle Word for 64-bit Registers	6-12
6.4.11	Packed Shuffle Word for 128-bit Registers.....	6-13
6.4.12	Shuffle Bytes.....	6-13
6.4.13	Conditional Data Movement	6-14
6.4.14	Unpacking/interleaving 64-bit Data in 128-bit Registers	6-14
6.4.15	Data Movement	6-14
6.4.16	Conversion Instructions	6-14
6.5	GENERATING CONSTANTS.....	6-14
6.6	BUILDING BLOCKS	6-15
6.6.1	Absolute Difference of Unsigned Numbers	6-15
6.6.2	Absolute Difference of Signed Numbers.....	6-16
6.6.3	Absolute Value	6-16
6.6.4	Pixel Format Conversion	6-17
6.6.5	Endian Conversion	6-18
6.6.6	Clipping to an Arbitrary Range [High, Low]	6-19
6.6.6.1	Highly Efficient Clipping	6-19
6.6.6.2	Clipping to an Arbitrary Unsigned Range [High, Low].....	6-21
6.6.7	Packed Max/Min of Byte, Word and Dword	6-21
6.6.8	Packed Multiply Integers	6-21
6.6.9	Packed Sum of Absolute Differences.....	6-22
6.6.10	MPSADBW and PHMINPOSUW	6-22
6.6.11	Packed Average (Byte/Word).....	6-22
6.6.12	Complex Multiply by a Constant.....	6-22
6.6.13	Packed 64-bit Add/Subtract	6-23
6.6.14	128-bit Shifts	6-23
6.6.15	PTEST and Conditional Branch	6-23
6.6.16	Vectorization of Heterogeneous Computations across Loop Iterations.....	6-24
6.6.17	Vectorization of Control Flows in Nested Loops	6-25
6.7	MEMORY OPTIMIZATIONS	6-27
6.7.1	Partial Memory Accesses.....	6-28
6.7.2	Increasing Bandwidth of Memory Fills and Video Fills	6-29
6.7.2.1	Increasing Memory Bandwidth Using the MOVDQ Instruction.....	6-29
6.7.2.2	Increasing Memory Bandwidth by Loading and Storing to and from the Same DRAM Page.....	6-29
6.7.2.3	Increasing UC and WC Store Bandwidth by Using Aligned Stores.....	6-30

6.7.3	Reverse Memory Copy	6-30
6.8	CONVERTING FROM 64-BIT TO 128-BIT SIMD INTEGERS	6-33
6.8.1	SIMD Optimizations and Microarchitectures	6-33
6.8.1.1	Packed SSE2 Integer versus MMX Instructions	6-33
6.8.1.2	Work-around for False Dependency Issue	6-34
6.9	TUNING PARTIALLY VECTORIZABLE CODE	6-34
6.10	PARALLEL MODE AES ENCRYPTION AND DECRYPTION	6-37
6.10.1	AES Counter Mode of Operation	6-37
6.10.2	AES Key Expansion Alternative	6-45
6.10.3	Enhancement in Haswell Microarchitecture	6-47
6.10.3.1	AES and Multi-Buffer Cryptographic Throughput	6-47
6.10.3.2	PCLMULQDQ Improvement	6-47
6.11	LIGHT-WEIGHT DECOMPRESSION AND DATABASE PROCESSING	6-47
6.11.1	Reduced Dynamic Range Datasets	6-48
6.11.2	Compression and Decompression Using SIMD Instructions	6-48

CHAPTER 7

OPTIMIZING FOR SIMD FLOATING-POINT APPLICATIONS

7.1	GENERAL RULES FOR SIMD FLOATING-POINT CODE	7-1
7.2	PLANNING CONSIDERATIONS	7-1
7.3	USING SIMD FLOATING-POINT WITH X87 FLOATING-POINT	7-2
7.4	SCALAR FLOATING-POINT CODE	7-2
7.5	DATA ALIGNMENT	7-2
7.5.1	Data Arrangement	7-2
7.5.1.1	Vertical versus Horizontal Computation	7-3
7.5.1.2	Data Swizzling	7-5
7.5.1.3	Data Deswizzling	7-7
7.5.1.4	Horizontal ADD Using SSE	7-8
7.5.2	Use of CVTTSS2PI/CVTTSS2SI Instructions	7-10
7.5.3	Flush-to-Zero and Denormals-are-Zero Modes	7-10
7.6	SIMD OPTIMIZATIONS AND MICROARCHITECTURES	7-11
7.6.1	SIMD Floating-point Programming Using SSE3	7-11
7.6.1.1	SSE3 and Complex Arithmetics	7-12
7.6.1.2	Packed Floating-Point Performance in Intel Core Duo Processor	7-14
7.6.2	Dot Product and Horizontal SIMD Instructions	7-14
7.6.3	Vector Normalization	7-16
7.6.4	Using Horizontal SIMD Instruction Sets and Data Layout	7-18
7.6.4.1	SOA and Vector Matrix Multiplication	7-20

CHAPTER 8

INT8 DEEP LEARNING INFERENCE

8.1	INTRODUCING INT8 AS DATA TYPE FOR DEEP LEARNING INFERENCE	8-1
8.2	INTRODUCING INTEL® DL BOOST	8-1
8.2.1	Multiply and Add Unsigned and Signed Bytes (VPDPBUSD Instruction)	8-2
8.2.2	Multiply and Add Signed Word Integers (VPDPWSSD Instruction)	8-4
8.3	GENERAL OPTIMIZATIONS	8-4
8.3.1	Memory Layout	8-4
8.3.2	Quantization	8-4
8.3.2.1	Quantization of Weights	8-5
8.3.2.2	Quantization of Activations	8-5
8.3.2.3	Quantizing Negative Activations	8-6
8.3.3	Multicore Considerations	8-6
8.3.3.1	Large Batch (Throughput Workload)	8-6
8.3.3.2	Small Batch (Throughput at Latency Workload)	8-6
8.3.3.3	NUMA	8-6
8.4	CNNS	8-7
8.4.1	Convolutional Layers	8-7
8.4.1.1	Direct Convolution	8-7
	Memory Layout	8-7
	Matrix Multiplication	8-9
	Blocking	8-9
	Direct Convolution Example	8-10

8.4.1.2	Convolutional Layers with Low OFM Count	8-13
8.4.2	Post Convolution	8-15
8.4.2.1	Fused Quantization/Dequantization	8-15
8.4.2.2	ReLu	8-16
8.4.2.3	EltWise	8-17
8.4.2.4	Pooling	8-17
8.4.2.5	Pixel Shuffler	8-19
8.5	LSTM NETWORKS	8-21
8.5.1	Fused LSTM Embedding	8-21
8.5.2	Fused post GEMM	8-21
8.5.3	Dynamic Batch Size	8-24
8.5.4	NMT Example: Beam Search Decoder Get Top K	8-24

CHAPTER 9

OPTIMIZING CACHE USAGE

9.1	GENERAL PREFETCH CODING GUIDELINES	9-1
9.2	PREFETCH AND CACHEABILITY INSTRUCTIONS	9-2
9.3	PREFETCH	9-2
9.3.1	Software Data Prefetch	9-2
9.3.2	Prefetch Instructions	9-3
9.3.3	Prefetch and Load Instructions	9-4
9.4	CACHEABILITY CONTROL	9-5
9.4.1	The Non-temporal Store Instructions	9-5
9.4.1.1	Fencing	9-5
9.4.1.2	Streaming Non-temporal Stores	9-6
9.4.1.3	Memory Type and Non-temporal Stores	9-6
9.4.1.4	Write-Combining	9-6
9.4.2	Streaming Store Usage Models	9-7
9.4.2.1	Coherent Requests	9-7
9.4.2.2	Non-coherent requests	9-7
9.4.3	Streaming Store Instruction Descriptions	9-7
9.4.4	The Streaming Load Instruction	9-8
9.4.5	FENCE Instructions	9-8
9.4.5.1	SFENCE Instruction	9-8
9.4.5.2	LFENCE Instruction	9-8
9.4.5.3	MFENCE Instruction	9-9
9.4.6	CLFLUSH Instruction	9-9
9.4.7	CLFLUSHOPT Instruction	9-10
9.5	MEMORY OPTIMIZATION USING PREFETCH	9-12
9.5.1	Software-Controlled Prefetch	9-12
9.5.2	Hardware Prefetch	9-12
9.5.3	Example of Effective Latency Reduction with Hardware Prefetch	9-13
9.5.4	Example of Latency Hiding with S/W Prefetch Instruction	9-14
9.5.5	Software Prefetching Usage Checklist	9-15
9.5.6	Software Prefetch Scheduling Distance	9-16
9.5.7	Software Prefetch Concatenation	9-16
9.5.8	Minimize Number of Software Prefetches	9-17
9.5.9	Mix Software Prefetch with Computation Instructions	9-19
9.5.10	Software Prefetch and Cache Blocking Techniques	9-19
9.5.11	Hardware Prefetching and Cache Blocking Techniques	9-23
9.5.12	Single-pass versus Multi-pass Execution	9-24
9.6	MEMORY OPTIMIZATION USING NON-TEMPORAL STORES	9-25
9.6.1	Non-temporal Stores and Software Write-Combining	9-25
9.6.2	Cache Management	9-26
9.6.2.1	Video Encoder	9-26
9.6.2.2	Video Decoder	9-26
9.6.2.3	Conclusions from Video Encoder and Decoder Implementation	9-27
9.6.2.4	Optimizing Memory Copy Routines	9-27
9.6.2.5	Using the 8-byte Streaming Stores and Software Prefetch	9-28
9.6.2.6	Using 16-byte Streaming Stores and Hardware Prefetch	9-29
9.6.2.7	Performance Comparisons of Memory Copy Routines	9-30
9.6.3	Deterministic Cache Parameters	9-30
9.6.3.1	Cache Sharing Using Deterministic Cache Parameters	9-31
9.6.3.2	Cache Sharing in Single-Core or Multicore	9-32

9.6.3.3	Determine Prefetch Stride	9-32
---------	---------------------------------	------

CHAPTER 10 SUB-NUMA CLUSTERING

10.1	SUB-NUMA CLUSTERING	10-1
10.2	COMPARISON WITH CLUSTER-ON-DIE	10-1
10.3	SNC USAGE	10-2
10.3.1	How to Check NUMA Configuration	10-2
10.3.2	MPI Optimizations for SNC	10-7
10.3.3	SNC Performance Comparison	10-8

CHAPTER 11 MULTICORE AND HYPER-THREADING TECHNOLOGY

11.1	PERFORMANCE AND USAGE MODELS	11-1
11.1.1	Multithreading	11-1
11.1.2	Multitasking Environment	11-2
11.2	PROGRAMMING MODELS AND MULTITHREADING	11-3
11.2.1	Parallel Programming Models	11-4
11.2.1.1	Domain Decomposition	11-4
11.2.2	Functional Decomposition	11-4
11.2.3	Specialized Programming Models	11-4
11.2.3.1	Producer-Consumer Threading Models	11-5
11.2.4	Tools for Creating Multithreaded Applications	11-7
11.2.4.1	Programming with OpenMP Directives	11-8
11.2.4.2	Automatic Parallelization of Code	11-8
11.2.4.3	Supporting Development Tools	11-8
11.3	OPTIMIZATION GUIDELINES	11-8
11.3.1	Key Practices of Thread Synchronization	11-8
11.3.2	Key Practices of System Bus Optimization	11-9
11.3.3	Key Practices of Memory Optimization	11-9
11.3.4	Key Practices of Execution Resource Optimization	11-9
11.3.5	Generality and Performance Impact	11-10
11.4	THREAD SYNCHRONIZATION	11-10
11.4.1	Choice of Synchronization Primitives	11-10
11.4.2	Synchronization for Short Periods	11-11
11.4.3	Optimization with Spin-Locks	11-13
11.4.4	Synchronization for Longer Periods	11-13
11.4.4.1	Avoid Coding Pitfalls in Thread Synchronization	11-14
11.4.5	Prevent Sharing of Modified Data and False-Sharing	11-14
11.4.6	Placement of Shared Synchronization Variable	11-15
11.5	SYSTEM BUS OPTIMIZATION	11-16
11.5.1	Conserve Bus Bandwidth	11-17
11.5.2	Understand the Bus and Cache Interactions	11-17
11.5.3	Avoid Excessive Software Prefetches	11-17
11.5.4	Improve Effective Latency of Cache Misses	11-18
11.5.5	Use Full Write Transactions to Achieve Higher Data Rate	11-18
11.6	MEMORY OPTIMIZATION	11-19
11.6.1	Cache Blocking Technique	11-19
11.6.2	Shared-Memory Optimization	11-19
11.6.2.1	Minimize Sharing of Data between Physical Processors	11-19
11.6.2.2	Batched Producer-Consumer Model	11-20
11.6.3	Eliminate 64-KByte Aliased Data Accesses	11-21
11.7	FRONT END OPTIMIZATION	11-21
11.7.1	Avoid Excessive Loop Unrolling	11-21
11.8	AFFINITIES AND MANAGING SHARED PLATFORM RESOURCES	11-22
11.8.1	Topology Enumeration of Shared Resources	11-23
11.8.2	Non-Uniform Memory Access	11-23
11.9	OPTIMIZATION OF OTHER SHARED RESOURCES	11-25
11.9.1	Expanded Opportunity for HT Optimization	11-25

CHAPTER 12**INTEL® OPTANE™ DC PERSISTENT MEMORY**

12.1	MEMORY MODE AND APP-DIRECT MODE	12-1
12.1.1	Memory Mode	12-1
12.1.2	App Direct Mode	12-1
12.1.3	Selecting a Mode	12-2
12.2	DEVICE CHARACTERISTICS OF INTEL® OPTANE™ DC PERSISTENT MEMORY MODULE ..	12-3
12.2.1	Intel® Optane™ DC Persistent Memory Module Latency	12-4
12.2.2	Read vs. Write Bandwidth	12-4
12.2.3	Number of Threads for Optimal Bandwidth	12-5
12.3	PLATFORM IMPLICATIONS OF HANDLING A SECOND TYPE OF MEMORY	12-8
12.3.1	Multi-Processor Cache Coherence	12-8
12.3.2	Shared Queues in the Memory Hierarchy	12-9
12.4	IMPLEMENTING PERSISTENCE FOR MEMORY	12-9
12.5	POWER CONSUMPTION	12-10
12.5.1	Read-Write Equivalence	12-10
12.5.2	Spatial and Temporal Locality	12-12

CHAPTER 13**64-BIT MODE CODING GUIDELINES**

13.1	INTRODUCTION	13-1
13.2	CODING RULES AFFECTING 64-BIT MODE	13-1
13.2.1	Use Legacy 32-Bit Instructions When Data Size Is 32 Bits	13-1
13.2.2	Use Extra Registers to Reduce Register Pressure	13-1
13.2.3	Effective Use of 64-Bit by 64-Bit Multiplication	13-2
13.2.4	Replace 128-bit Integer Division with 128-bit Multiplication	13-2
13.2.5	Sign Extension to Full 64-Bits	13-4
13.3	ALTERNATE CODING RULES FOR 64-BIT MODE	13-5
13.3.1	Use 64-Bit Registers Instead of Two 32-Bit Registers for 64-Bit Arithmetic Result	13-5
13.3.2	Using Software Prefetch	13-6

CHAPTER 14**SSE4.2 AND SIMD PROGRAMMING FOR TEXT-PROCESSING/LEXING/PARSING**

14.1	SSE4.2 STRING AND TEXT INSTRUCTIONS	14-1
14.1.1	CRC32	14-4
14.2	USING SSE4.2 STRING AND TEXT INSTRUCTIONS	14-5
14.2.1	Unaligned Memory Access and Buffer Size Management	14-5
14.2.2	Unaligned Memory Access and String Library	14-6
14.3	SSE4.2 APPLICATION CODING GUIDELINE AND EXAMPLES	14-6
14.3.1	Null Character Identification (Strlen equivalent)	14-6
14.3.2	White-Space-Like Character Identification	14-9
14.3.3	Substring Searches	14-11
14.3.4	String Token Extraction and Case Handling	14-18
14.3.5	Unicode Processing and PCMPxSTRy	14-22
14.3.6	Replacement String Library Function Using SSE4.2	14-26
14.4	SSE4.2 ENABLED NUMERICAL AND LEXICAL COMPUTATION	14-28
14.5	NUMERICAL DATA CONVERSION TO ASCII FORMAT	14-34
14.5.1	Large Integer Numeric Computation	14-48
14.5.1.1	MULX Instruction and Large Integer Numeric Computation	14-48

CHAPTER 15**OPTIMIZATIONS FOR INTEL® AVX, FMA AND AVX2**

15.1	INTEL® AVX INTRINSICS CODING	15-2
15.1.1	Intel® AVX Assembly Coding	15-4
15.2	NON-DESTRUCTIVE SOURCE (NDS)	15-6
15.3	MIXING AVX CODE WITH SSE CODE	15-7
15.3.1	Mixing Intel® AVX and Intel SSE in Function Calls	15-9
15.4	128-BIT LANE OPERATION AND AVX	15-10
15.4.1	Programming With the Lane Concept	15-11
15.4.2	Strided Load Technique	15-11

15.4.3	The Register Overlap Technique	15-14
15.5	DATA GATHER AND SCATTER	15-15
15.5.1	Data Gather	15-15
15.5.2	Data Scatter	15-17
15.6	DATA ALIGNMENT FOR INTEL® AVX	15-19
15.6.1	Align Data to 32 Bytes	15-19
15.6.2	Consider 16-Byte Memory Access when Memory is Unaligned	15-20
15.6.3	Prefer Aligned Stores Over Aligned Loads	15-22
15.7	L1D CACHE LINE REPLACEMENTS	15-22
15.8	4K ALIASING	15-23
15.9	CONDITIONAL SIMD PACKED LOADS AND STORES	15-23
15.9.1	Conditional Loops	15-24
15.10	MIXING INTEGER AND FLOATING-POINT CODE	15-26
15.11	HANDLING PORT 5 PRESSURE	15-29
15.11.1	Replace Shuffles with Blends	15-29
15.11.2	Design Algorithm With Fewer Shuffles	15-31
15.11.3	Perform Basic Shuffles on Load Ports	15-34
15.12	DIVIDE AND SQUARE ROOT OPERATIONS	15-35
15.12.1	Single-Precision Divide	15-37
15.12.2	Single-Precision Reciprocal Square Root	15-38
15.12.3	Single-Precision Square Root	15-40
15.13	OPTIMIZATION OF ARRAY SUB SUM EXAMPLE	15-42
15.14	HALF-PRECISION FLOATING-POINT CONVERSIONS	15-44
15.14.1	Packed Single-Precision to Half-Precision Conversion	15-45
15.14.2	Packed Half-Precision to Single-Precision Conversion	15-46
15.14.3	Locality Consideration for using Half-Precision FP to Conserve Bandwidth	15-46
15.15	FUSED MULTIPLY-ADD (FMA) INSTRUCTIONS GUIDELINES	15-47
15.15.1	Optimizing Throughput with FMA and Floating-Point Add/MUL	15-48
15.15.2	Optimizing Throughput with Vector Shifts	15-50
15.16	AVX2 OPTIMIZATION GUIDELINES	15-51
15.16.1	Multi-Buffering and AVX2	15-55
15.16.2	Modular Multiplication and AVX2	15-55
15.16.3	Data Movement Considerations	15-56
15.16.3.1	SIMD Heuristics to implement Memcpy()	15-56
15.16.3.2	Memcpy() Implementation Using Enhanced REP MOVSB	15-57
15.16.3.3	Memset() Implementation Considerations	15-57
15.16.3.4	Hoisting Memcpy/Memset Ahead of Consuming Code	15-58
15.16.3.5	256-bit Fetch versus Two 128-bit Fetches	15-59
15.16.3.6	Mixing MULX and AVX2 Instructions	15-59
15.16.4	Considerations for Gather Instructions	15-65
15.16.4.1	Strided Loads	15-68
15.16.4.2	Adjacent Loads	15-69
15.16.5	AVX2 Conversion Remedy to MMX Instruction Throughput Limitation	15-71

CHAPTER 16 INTEL® TSX RECOMMENDATIONS

16.1	INTRODUCTION	16-1
16.1.1	Optimization Outline	16-2
16.2	APPLICATION-LEVEL TUNING AND OPTIMIZATIONS	16-2
16.2.1	Existing TSX-enabled Locking Libraries	16-3
16.2.1.1	Libraries allowing lock elision for unmodified programs	16-3
16.2.1.2	Libraries requiring program modifications	16-3
16.2.2	Initial Checks	16-3
16.2.3	Run and Profile the Application	16-3
16.2.4	Minimize Transactional Aborts	16-4
16.2.4.1	Transactional Aborts due to Data Conflicts	16-5
16.2.4.2	Transactional Aborts due to Limited Transactional Resources	16-6
16.2.4.3	Lock Elision Specific Transactional Aborts	16-7
16.2.4.4	HLE Specific Transactional Aborts	16-7
16.2.4.5	Miscellaneous Transactional Aborts	16-8
16.2.5	Using Transactional-Only Code Paths	16-9
16.2.6	Dealing with Transactional Regions or Paths that Abort at a High Rate	16-9
16.2.6.1	Transitioning to Non-Elided Execution without Aborting	16-9
16.2.6.2	Forcing an Early Abort	16-10

16.2.6.3	Not Eliding Selected Locks.....	16-10
16.3	DEVELOPING AN INTEL TSX ENABLED SYNCHRONIZATION LIBRARY.....	16-10
16.3.1	Adding HLE Prefixes	16-10
16.3.2	Elision Friendly Critical Section Locks.....	16-10
16.3.3	Using HLE or RTM for Lock Elision	16-11
16.3.4	An example wrapper for lock elision using RTM.....	16-11
16.3.5	Guidelines for the RTM fallback handler	16-12
16.3.6	Implementing Elision-Friendly Locks using Intel® TSX.....	16-13
16.3.6.1	Implementing a Simple Spinlock using HLE.....	16-13
16.3.6.2	Implementing Reader-Writer Locks using Intel TSX	16-15
16.3.6.3	Implementing Ticket Locks using Intel® TSX	16-15
16.3.6.4	Implementing Queue-Based Locks using Intel® TSX	16-15
16.3.7	Eliding Application-Specific Meta-Locks using Intel® TSX.....	16-16
16.3.8	Avoiding Persistent Non-Elided Execution.....	16-17
16.3.9	Reading the Value of an Elided Lock in RTM-based libraries	16-19
16.3.10	Intermixing HLE and RTM	16-19
16.4	USING THE PERFORMANCE MONITORING SUPPORT FOR INTEL® TSX	16-20
16.4.1	Measuring Transactional Success	16-21
16.4.2	Finding locks to elide and verifying all locks are elided.....	16-21
16.4.3	Sampling Transactional Aborts	16-21
16.4.4	Classifying Aborts using a Profiling Tool.....	16-21
16.4.5	XABORT Arguments for RTM fallback handlers	16-22
16.4.6	Call Graphs for Transactional Aborts.....	16-23
16.4.7	Last Branch Records and Transactional Aborts	16-23
16.4.8	Profiling and Testing Intel TSX Software using the Intel® SDE	16-23
16.4.9	HLE Specific Performance Monitoring Events.....	16-24
16.4.10	Computing Useful Metrics for Intel® TSX	16-25
16.5	PERFORMANCE GUIDELINES	16-25
16.6	DEBUGGING GUIDELINES	16-26
16.7	COMMON INTRINSICS FOR INTEL® TSX	16-26
16.7.1	RTM C Intrinsics	16-26
16.7.1.1	Emulated RTM intrinsics on older gcc compatible compilers.....	16-27
16.7.2	HLE Intrinsics on gcc and Other Linux Compatible Compilers.....	16-28
16.7.2.1	Generating HLE intrinsics with gcc4.8.....	16-28
16.7.2.2	C++11 atomic support	16-29
16.7.2.3	Emulating HLE intrinsics with older gcc-compatible compilers.....	16-29
16.7.3	HLE intrinsics on Windows C/C++ compilers	16-29

CHAPTER 17 POWER OPTIMIZATION FOR MOBILE USAGES

17.1	OVERVIEW	17-1
17.2	MOBILE USAGE SCENARIOS.....	17-1
17.2.1	Intelligent Energy Efficient Software	17-2
17.3	ACPI C-STATES	17-3
17.3.1	Processor-Specific C4 and Deep C4 States	17-4
17.3.2	Processor-Specific Deep C-States and Intel® Turbo Boost Technology.....	17-4
17.3.3	Processor-Specific Deep C-States for Sandy Bridge Microarchitecture	17-5
17.3.4	Intel® Turbo Boost Technology 2.0	17-6
17.4	GUIDELINES FOR EXTENDING BATTERY LIFE	17-6
17.4.1	Adjust Performance to Meet Quality of Features	17-6
17.4.2	Reducing Amount of Work.....	17-7
17.4.3	Platform-Level Optimizations.....	17-7
17.4.4	Handling Sleep State Transitions	17-8
17.4.5	Using Enhanced Intel SpeedStep® Technology	17-8
17.4.6	Enabling Intel® Enhanced Deeper Sleep.....	17-9
17.4.7	Multicore Considerations	17-10
17.4.7.1	Enhanced Intel SpeedStep® Technology	17-10
17.4.7.2	Thread Migration Considerations	17-10
17.4.7.3	Multicore Considerations for C-States.....	17-11
17.5	TUNING SOFTWARE FOR INTELLIGENT POWER CONSUMPTION	17-12
17.5.1	Reduction of Active Cycles	17-12
17.5.1.1	Multi-threading to reduce Active Cycles.....	17-12
17.5.1.2	Vectorization.....	17-13
17.5.2	PAUSE and Sleep(0) Loop Optimization.....	17-14

17.5.3	Spin-Wait Loops	17-15
17.5.4	Using Event Driven Service Instead of Polling in Code	17-15
17.5.5	Reducing Interrupt Rate	17-15
17.5.6	Reducing Privileged Time	17-15
17.5.7	Setting Context Awareness in the Code	17-16
17.5.8	Saving Energy by Optimizing for Performance	17-17
17.6	PROCESSOR SPECIFIC POWER MANAGEMENT OPTIMIZATION FOR SYSTEM SOFTWARE	17-17
17.6.1	Power Management Recommendation of Processor-Specific Inactive State Configurations	17-17
17.6.1.1	Balancing Power Management and Responsiveness of Inactive To Active State Transitions	17-19

CHAPTER 18

SOFTWARE OPTIMIZATION FOR INTEL® AVX-512 INSTRUCTIONS

18.1	BASIC INTEL® AVX-512 VS. INTEL® AVX2 CODING	18-2
18.1.1	Intrinsic Coding	18-2
18.1.2	Assembly Coding	18-4
18.2	MASKING	18-6
18.2.1	Masking Example	18-7
18.2.2	Masking Cost	18-11
18.2.3	Masking vs. Blending	18-11
18.2.4	Nested Conditions / Mask Aggregation	18-13
18.2.5	Memory Masking Microarchitecture Improvements	18-14
18.2.6	Peeling and Remainder Masking	18-15
18.3	FORWARDING AND UNMASKED OPERATIONS	18-16
18.4	FORWARDING AND MEMORY MASKING	18-17
18.5	DATA COMPRESS	18-17
18.5.1	Data Compress Example	18-18
18.6	DATA EXPAND	18-22
18.6.1	Data Expand Example	18-23
18.7	TERNARY LOGIC	18-25
18.7.1	Ternary Logic Example 1	18-25
18.7.2	Ternary Logic Example 2	18-27
18.8	NEW SHUFFLE INSTRUCTIONS	18-28
18.8.1	Two Source Permute Example	18-29
18.9	BROADCAST	18-32
18.9.1	Embedded Broadcast	18-32
18.9.2	Broadcast Executed on Load Ports	18-32
18.10	EMBEDDED ROUNDING	18-33
18.10.1	Static Rounding Mode	18-33
18.11	SCATTER INSTRUCTION	18-35
18.11.1	Data Scatter Example	18-35
18.12	STATIC ROUNDING MODES, SUPPRESS-ALL-EXCEPTIONS (SAE)	18-38
18.13	QWORD INSTRUCTION SUPPORT	18-38
18.13.1	QUADWORD Support in Arithmetic Instructions	18-39
18.13.2	QUADWORD Support in Convert Instructions	18-42
18.13.3	QUADWORD Support for Convert with Truncation Instructions	18-43
18.14	VECTOR LENGTH ORTHOGONALITY	18-43
18.15	INTEL® AVX-512 INSTRUCTIONS FOR TRANSCENDENTAL SUPPORT	18-43
18.15.1	VRCPL14, VRSQRT14 - Software Sequences for 1/x, x/y, sqrt(x)	18-43
18.15.1.1	Application Examples	18-43
18.15.2	VGETMANT VGETEXP - Vector Get Mantissa and Vector Get Exponent	18-44
18.15.2.1	Application Examples	18-44
18.15.3	VRNDSCALE - Vector Round Scale	18-44
18.15.3.1	Application Examples	18-44
18.15.4	VREDUCE - Vector Reduce	18-45
18.15.4.1	Application Examples	18-45
18.15.5	VSCALEF - Vector Scale	18-45
18.15.5.1	Application Examples	18-45
18.15.6	VFPCLASS - Vector Floating Point Class	18-46
18.15.6.1	Application Examples	18-46
18.15.7	VPERM, VPERM12, VPERM22 - Small Table Lookup Implementation	18-46
18.15.7.1	Application Examples	18-46
18.16	CONFLICT DETECTION	18-46
18.16.1	Vectorization with Conflict Detection	18-47
18.16.2	Sparse Dot Product with VPCONFLICT	18-51

18.17	INTEL® AVX-512 VECTOR BYTE MANIPULATION INSTRUCTIONS (VBMI).....	18-53
18.17.1	Permute Packet Bytes Elements Across Lanes (VPERMB).....	18-54
18.17.2	Two-Source Byte Permute Across Lanes (VPERMI2B, VPERMT2B).....	18-55
18.17.3	Select Packed Unaligned Bytes from Quadword Sources (VPMULTISHIFTQB).....	18-58
18.18	FMA LATENCY.....	18-60
18.19	MIXING INTEL® AVX EXTENSIONS OR INTEL® AVX-512 EXTENSIONS WITH INTEL® STREAMING SIMD EXTENSIONS (INTEL® SSE) CODE.....	18-61
18.20	MIXING ZMM VECTOR CODE WITH XMM/YMM.....	18-62
18.21	SERVERS WITH A SINGLE FMA UNIT.....	18-63
18.22	GATHER/SCATTER TO SHUFFLE (G2S/STS).....	18-68
18.22.1	Gather to Shuffle in Strided Loads.....	18-68
18.22.2	Scatter to Shuffle in Strided Stores.....	18-69
18.22.3	Gather to Shuffle in Adjacent Loads.....	18-70
18.23	DATA ALIGNMENT.....	18-71
18.23.1	Align Data to 64 Bytes.....	18-71
18.24	DYNAMIC MEMORY ALLOCATION AND MEMORY ALIGNMENT.....	18-73
18.25	DIVISION AND SQUARE ROOT OPERATIONS.....	18-73
18.25.1	Divide and Square Root Approximation Methods.....	18-74
18.25.2	Divide and Square Root Performance.....	18-75
18.25.3	Approximation Latencies.....	18-75
18.25.4	Code Snippets.....	18-78
18.26	CLDEMOTE.....	18-84
18.26.1	Producer-Consumer Communication in Software.....	18-84
18.27	TIPS ON COMPILER USAGE.....	18-85

CHAPTER 19

INTEL® ADVANCED VECTOR EXTENSIONS 512 - FP16 INSTRUCTION SET FOR INTEL® XEON® PROCESSORS

19.1	INTRODUCTION.....	19-1
19.1.1	Terminology.....	19-1
19.2	OVERVIEW.....	19-2
19.3	FP16 NUMERIC INSTRUCTIONS.....	19-3
19.3.1	Data Type Support.....	19-3
19.3.2	Overview of Intrinsics.....	19-4
19.3.3	Fundamental Complex-Valued Support.....	19-5
19.3.4	Using Intel® AVX-512 Bit Masks for Real-Valued Operations.....	19-6
19.3.5	Using Intel® AVX-512 Bit Masks for Complex-Valued Operations.....	19-7
19.4	NUMERICS.....	19-9
19.4.1	Introduction to FP16 Number Format.....	19-10
19.4.2	Observations on Representing Numbers in FP16 Format.....	19-10
19.4.3	Numeric Accuracy Guarantees.....	19-12
19.4.4	Handling Denormal Values.....	19-13
19.4.5	Embedded Rounding.....	19-13
19.4.6	Legacy FP16 Data Type Conversion.....	19-14
19.4.7	FP16 Conversions to and from Other Data Types.....	19-14
19.4.8	Approximation Instructions and Their Uses.....	19-15
19.4.8.1	Approximate Reciprocal.....	19-15
19.4.8.2	Approximate Division.....	19-15
19.4.8.3	Approximate Reciprocal Square Root.....	19-16
19.4.9	Approximate Square Root.....	19-17
19.5	USING EXISTING INTEL® AVX-512 INSTRUCTIONS TO AUGMENT FP16 SUPPORT.....	19-17
19.5.1	Using Existing Instructions to Extend Intel® AVX-512 FP16 Intrinsics.....	19-17
19.5.2	Common Convenience Intrinsics.....	19-18
19.5.3	Using Integer Comparisons for Fast Floating-Point Comparison.....	19-18
19.6	MATH LIBRARY SUPPORT.....	19-19

CHAPTER 20

INTEL® ADVANCED MATRIX EXTENSIONS (INTEL® AMX)

20.1	DETECTING INTEL® AMX SUPPORT.....	20-2
20.2	INTEL® AMX MICROARCHITECTURE OVERVIEW.....	20-2
20.2.1	Intel AMX Frequencies.....	20-2
20.3	INTEL® AMX INSTRUCTIONS THROUGHPUT AND LATENCY.....	20-3

20.4	DATA STRUCTURE ALIGNMENT	20-3
20.5	GEMMS / CONVOLUTIONS	20-4
20.5.1	Notation	20-4
20.5.2	Tiles in the Intel® AMX Architecture	20-4
	TileLoad and TileStore Instructions	20-5
20.5.3	B Matrix Layout	20-6
20.5.4	Straightforward GEMM Implementation	20-8
20.5.5	Optimizations	20-10
20.5.5.1	Minimizing Tile Loads	20-10
	Location of the K Loop: Outside of the M_ACC and N_ACC Loops	20-10
	Pre-loading Innermost Loop Tiles	20-10
	2D Accumulator Array vs. 1D Accumulator Array	20-11
20.5.5.2	Software Pipelining of Tile Loads and Stores	20-12
20.5.5.3	Optimized GEMM Implementation	20-12
	Variable Input Dimensions	20-15
20.5.5.4	Direct Convolution with Intel® AMX	20-15
	Activations Layout	20-15
	Weights Layout	20-16
20.5.5.5	Convolution - Matrix-like Multiplications and Summations Equivalence	20-17
20.5.5.6	Optimized Convolution Implementation	20-19
	Location of the KH, KW Loops	20-21
20.6	CACHE BLOCKING	20-21
20.6.1	Optimized Convolution Implementation with Cache Blocking	20-21
	Intel AMX-Specific Considerations	20-23
20.7	MINI-BATCHING IN LARGE BATCH INFERENCE	20-24
20.8	NON-TEMPORAL TILE LOADS	20-25
	Priority Inversion Scenarios with Temporal Loads	20-25
	Scenario 1:	20-25
	Scenario 2:	20-26
	Solution to Priority Inversions: Non-temporal Loads	20-27
20.9	USING LARGE TILES IN SMALL CONVOLUTIONS TO MAXIMIZE DATA REUSE	20-27
20.10	HANDLING INCONVENIENTLY SIZED ACTIVATIONS	20-28
20.11	POST-CONVOLUTION OPTIMIZATIONS	20-29
20.11.1	Post-convolution Fusion	20-29
20.11.2	Intel® AMX and Intel® AVX-512 Interleaving (SW Pipelining)	20-32
20.11.3	AVOIDING THE H/W OVERHEAD OF PORT 5 FREQUENT OPEN/CLOSE OPERATIONS	20-34
20.11.4	Post-Conv Multiple OFM Accumulation and Efficient Down-Conversion	20-35
20.12	INPUT AND OUTPUT BUFFERS REUSE (AKA DOUBLE BUFFERING)	20-37
20.13	SOFTWARE PREFETCHES	20-38
20.13.1	Software Prefetch for Convolution and GEMM Layers	20-38
20.13.1.1	The Prefetch Strategy	20-38
20.13.1.2	Prefetch Distance	20-39
20.13.1.3	To Prefetch A or Prefetch B?	20-39
20.13.1.4	To Prefetch or not to Prefetch C?	20-40
20.13.2	Software Prefetch for Embedding Layer	20-40
20.14	STORE TO LOAD FORWARDING	20-40
20.15	MATRIX TRANSPOSE	20-41
20.15.1	Flat-to-Flat Transpose of BF16 Data	20-41
20.15.2	VNNI-to-VNNI Transpose	20-46
20.15.3	Flat-to-VNNI Transpose	20-48
20.15.4	Flat-to-VNNI Re-layout	20-52
20.16	MULTI-THREADING CONSIDERATIONS	20-53
20.16.1	Thread Affinity	20-53
20.16.2	Hyper-Threading	20-53
20.16.3	Work Partitioning Between Cores	20-53
20.16.3.1	Partitioning over M	20-54
20.16.3.2	Partitioning over N	20-54
20.16.3.3	Partitioning over K	20-55
20.16.3.4	Memory Bandwidth Implications of Work Partitioning over Multiple Dimensions	20-55
20.16.4	Recommendation System Example	20-56
20.17	SPARSITY OPTIMIZATIONS FOR INTEL® AMX	20-58
20.18	TILECONFIG/TILERELEASE, CORE C-STATE, AND COMPILER ABI	20-60
20.18.1	ABI	20-60

20.18.2	Intrinsics	20-60
20.18.3	User Interface	20-61
20.18.4	Example	20-63
20.18.5	Compilation Option	20-65
20.19	INTEL® AMX STATE MANAGEMENT	20-66
20.19.1	Extended Feature Disable (XFD)	20-67
20.19.2	Alternate Signal Handler Stack in Linux Operating System	20-67
20.20	USING INTEL® AMX TO EMULATE HIGHER PRECISION GEMMS	20-67

CHAPTER 21

CRYPTOGRAPHY & FINITE FIELD ARITHMETIC ENHANCEMENTS

21.1	VECTOR AES	21-1
21.2	VPCLMULQDQ	21-2
21.3	GALOIS FIELD NEW INSTRUCTIONS	21-2
21.4	INTEGER FUSED MULTIPLY ACCUMULATE OPERATIONS (AVX512_IFMA - VPMADD52)	21-3

CHAPTER 22

INTEL® QUICKASSIST TECHNOLOGY

22.1	SOFTWARE DESIGN GUIDELINES	22-1
22.1.1	Polling vs. Interrupts (If Supported)	22-1
22.1.1.1	Interrupt Mode	22-1
22.1.1.2	Polling Mode	22-2
22.1.1.3	Recommendations	22-3
22.1.2	Use of Data Plane (DP) API vs. Traditional API	22-3
22.1.2.1	Batch Submission of Requests Using the Data Plane API	22-3
22.1.3	Synchronous (sync) vs. Asynchronous (async)	22-3
22.1.4	Buffer Lists	22-4
22.1.5	Maximum Number of Concurrent Requests	22-4
22.1.6	Symmetric Crypto Partial Operations	22-5
22.1.7	Reusing Sessions in QAT Environment	22-5
22.1.8	Maximizing QAT Device Utilization	22-5
22.1.9	Best Known Method (BKM) for Avoiding Performance Bottlenecks	22-5
22.1.10	Avoid Data Copies By Using SVM and ATS	22-6
22.1.11	Avoid Page Faults When Using SVM	22-6

CHAPTER 23

KNIGHTS LANDING MICROARCHITECTURE AND SOFTWARE OPTIMIZATION

23.1	KNIGHTS LANDING MICROARCHITECTURE	23-2
23.1.1	Front End	23-3
23.1.2	Out-of-Order Engine	23-3
23.1.3	UnTile	23-6
23.2	INTEL® AVX-512 CODING RECOMMENDATIONS FOR KNIGHTS LANDING MICROARCHITECTURE	23-7
23.2.1	Using Gather and Scatter Instructions	23-8
23.2.2	Using Enhanced Reciprocal Instructions	23-8
23.2.3	Using AVX-512CD Instructions	23-9
23.2.4	Using Intel® Hyper-Threading Technology	23-9
23.2.5	Front End Considerations	23-9
23.2.5.1	Instruction Decoder	23-10
23.2.5.2	Branching Indirectly Across a 4GB Boundary	23-10
23.2.6	Integer Execution Considerations	23-10
23.2.6.1	Flags usage	23-10
23.2.6.2	Integer Division	23-11
23.2.7	Optimizing FP and Vector Execution	23-11
23.2.7.1	Instruction Selection Considerations	23-11
23.2.7.2	Porting Intrinsics from Previous Generation	23-13
23.2.7.3	Vectorization Trade-Off Estimation	23-13
23.2.8	Memory Optimization	23-16
23.2.8.1	Data Alignment	23-16
23.2.8.2	Hardware Prefetcher	23-17
23.2.8.3	Software Prefetch	23-17
23.2.8.4	Memory Execution Cluster	23-17

23.2.8.5	Store Forwarding	23-18
23.2.8.6	Way, Set Conflicts	23-18
23.2.8.7	Streaming Store Versus Regular Store	23-19
23.2.8.8	Compiler Switches and Directives	23-19
23.2.8.9	Direct Mapped MCDRAM Cache	23-19

APPENDIX A APPLICATION PERFORMANCE TOOLS

A.1	COMPILERS	A-2
A.1.1	Recommended Optimization Settings for Intel® 64 and IA-32 Processors	A-2
A.1.2	Vectorization and Loop Optimization	A-3
A.1.2.1	Multithreading with OpenMP*	A-3
A.1.2.2	Automatic Multithreading	A-3
A.1.3	Inline Expansion of Library Functions (/Oi, /Oi-)	A-3
A.1.4	Interprocedural and Profile-Guided Optimizations	A-3
A.1.4.1	Interprocedural Optimization (IPO)	A-3
A.1.4.2	Profile-Guided Optimization (PGO)	A-4
A.1.5	Intel® Cilk™ Plus	A-4
A.2	PERFORMANCE LIBRARIES	A-4
A.2.1	Intel® Integrated Performance Primitives (Intel® IPP)	A-5
A.2.2	Intel® Math Kernel Library (Intel® MKL)	A-5
A.2.3	Intel® Threading Building Blocks (Intel® TBB)	A-5
A.2.4	Benefits Summary	A-5
A.3	PERFORMANCE PROFILERS	A-5
A.3.1	Intel® VTune™ Amplifier XE	A-6
A.3.1.1	Hardware Event-Based Sampling Analysis	A-6
A.3.1.2	Algorithm Analysis	A-6
A.3.1.3	Platform Analysis	A-6
A.4	THREAD AND MEMORY CHECKERS	A-6
A.4.1	Intel® Inspector	A-7
A.5	VECTORIZATION ASSISTANT	A-7
A.5.1	Intel® Advisor	A-7
A.6	CLUSTER TOOLS	A-7
A.6.1	Intel® Trace Analyzer and Collector	A-7
A.6.1.1	MPI Performance Snapshot	A-7
A.6.2	Intel® MPI Library	A-7
A.6.3	Intel® MPI Benchmarks	A-8
A.7	INTEL® ACADEMIC COMMUNITY	A-8

APPENDIX B USING PERFORMANCE MONITORING EVENTS

B.1	TOP-DOWN ANALYSIS METHOD	B-1
B.1.1	Top-Level	B-2
B.1.2	Frontend Bound	B-4
B.1.3	Backend Bound	B-4
B.1.4	Memory Bound	B-4
B.1.5	Core Bound	B-5
B.1.6	Bad Speculation	B-5
B.1.7	Retiring	B-6
B.1.8	Golden Cove Microarchitecture	B-6
B.1.9	Ice Lake Microarchitecture	B-6
B.1.10	Optane Persistent Memory	B-6
B.1.11	Skylake Microarchitecture	B-6
B.1.11.1	TMA Use Case 1	B-7
B.1.11.2	TMA Use Case 2	B-7
B.2	PERFORMANCE MONITORING AND MICROARCHITECTURE	B-8
B.3	INTEL® XEON® PROCESSOR 5500 SERIES	B-14
B.4	PERFORMANCE ANALYSIS TECHNIQUES FOR INTEL® XEON® PROCESSOR 5500 SERIES	B-15
B.4.1	Cycle Accounting and Uop Flow Analysis	B-16
B.4.1.1	Cycle Drill Down and Branch Mispredictions	B-17
B.4.1.2	Basic Block Drill Down	B-20
B.4.2	Stall Cycle Decomposition and Core Memory Accesses	B-21

B.4.2.1	Measuring Costs of Microarchitectural Conditions	B-21
B.4.3	Core PMU Precise Events	B-22
B.4.3.1	Precise Memory Access Events	B-23
B.4.3.2	Load Latency Event	B-24
B.4.3.3	Precise Execution Events	B-26
B.4.3.4	Last Branch Record (LBR)	B-27
B.4.3.5	Measuring Per-Core Bandwidth	B-31
B.4.3.6	Miscellaneous L1 and L2 Events for Cache Misses	B-32
B.4.3.7	TLB Misses	B-32
B.4.3.8	L1 Data Cache	B-33
B.4.4	Frontend Monitoring Events	B-33
B.4.4.1	Branch Mispredictions	B-33
B.4.4.2	Frontend Code Generation Metrics	B-33
B.4.5	Uncore Performance Monitoring Events	B-34
B.4.5.1	Global Queue Occupancy	B-34
B.4.5.2	Global Queue Port Events	B-36
B.4.5.3	Global Queue Snoop Events	B-36
B.4.5.4	L3 Events	B-37
B.4.6	Intel QuickPath Interconnect Home Logic (QHL)	B-37
B.4.7	Measuring Bandwidth From the Uncore	B-42
B.5	PERFORMANCE TUNING TECHNIQUES FOR SANDY BRIDGE MICROARCHITECTURE ...	B-43
B.5.1	Correlating Performance Bottleneck to Source Location	B-43
B.5.2	Hierarchical Top-Down Performance Characterization Methodology and Locating Performance Bottlenecks	B-44
B.5.2.1	Back End Bound Characterization	B-45
B.5.2.2	Core Bound Characterization	B-45
B.5.2.3	Memory Bound Characterization	B-46
B.5.3	Back End Stalls	B-47
B.5.4	Memory Sub-System Stalls	B-48
B.5.4.1	Accounting for Load Latency	B-48
B.5.4.2	Cache-line Replacement Analysis	B-50
B.5.4.3	Lock Contention Analysis	B-50
B.5.4.4	Other Memory Access Issues	B-51
B.5.5	Execution Stalls	B-53
B.5.5.1	Longer Instruction Latencies	B-53
B.5.5.2	Assists	B-53
B.5.6	Bad Speculation	B-54
B.5.6.1	Branch Mispredicts	B-54
B.5.7	Frontend Stalls	B-54
B.5.7.1	Understanding the Micro-op Delivery Rate	B-54
B.5.7.2	Understanding the Sources of the Micro-op Queue	B-56
B.5.7.3	The Decoded ICache	B-57
B.5.7.4	Issues in the Legacy Decode Pipeline	B-58
B.5.7.5	Instruction Cache	B-58
B.6	USING PERFORMANCE EVENTS OF INTEL® CORE™ SOLO AND INTEL® CORE™ DUO PROCESSORS	B-59
B.6.1	Understanding the Results in a Performance Counter	B-59
B.6.2	Ratio Interpretation	B-59
B.6.3	Notes on Selected Events	B-60
B.7	DRILL-DOWN TECHNIQUES FOR PERFORMANCE ANALYSIS	B-60
B.7.1	Cycle Composition at Issue Port	B-62
B.7.2	Cycle Composition of OOO Execution	B-62
B.7.3	Drill-Down on Performance Stalls	B-63
B.8	EVENT RATIOS FOR INTEL CORE MICROARCHITECTURE	B-64
B.8.1	Clocks Per Instructions Retired Ratio (CPI)	B-64
B.8.2	Front End Ratios	B-65
B.8.2.1	Code Locality	B-65
B.8.2.2	Branching and Front End	B-65
B.8.2.3	Stack Pointer Tracker	B-65
B.8.2.4	Macro-fusion	B-66
B.8.2.5	Length Changing Prefix (LCP) Stalls	B-66
B.8.2.6	Self Modifying Code Detection	B-66
B.8.3	Branch Prediction Ratios	B-66
B.8.3.1	Branch Mispredictions	B-66
B.8.3.2	Virtual Tables and Indirect Calls	B-66
B.8.3.3	Mispredicted Returns	B-67

B.8.4	Execution Ratios	B-67
B.8.4.1	Resource Stalls	B-67
B.8.4.2	ROB Read Port Stalls	B-67
B.8.4.3	Partial Register Stalls	B-67
B.8.4.4	Partial Flag Stalls	B-67
B.8.4.5	Bypass Between Execution Domains	B-67
B.8.4.6	Floating-Point Performance Ratios	B-68
B.8.5	Memory Sub-System - Access Conflicts Ratios	B-68
B.8.5.1	Loads Blocked by the L1 Data Cache	B-68
B.8.5.2	4K Aliasing and Store Forwarding Block Detection	B-68
B.8.5.3	Load Block by Preceding Stores	B-68
B.8.5.4	Memory Disambiguation	B-69
B.8.5.5	Load Operation Address Translation	B-69
B.8.6	Memory Sub-System - Cache Misses Ratios	B-69
B.8.6.1	Locating Cache Misses in the Code	B-69
B.8.6.2	L1 Data Cache Misses	B-69
B.8.6.3	L2 Cache Misses	B-69
B.8.7	Memory Sub-system - Prefetching	B-70
B.8.7.1	L1 Data Prefetching	B-70
B.8.7.2	L2 Hardware Prefetching	B-70
B.8.7.3	Software Prefetching	B-70
B.8.8	Memory Sub-system - TLB Miss Ratios	B-70
B.8.9	Memory Sub-system - Core Interaction	B-71
B.8.9.1	Modified Data Sharing	B-71
B.8.9.2	Fast Synchronization Penalty	B-71
B.8.9.3	Simultaneous Extensive Stores and Load Misses	B-71
B.8.10	Memory Sub-system - Bus Characterization	B-71
B.8.10.1	Bus Utilization	B-71
B.8.10.2	Modified Cache Lines Eviction	B-72

APPENDIX C

RUNTIME PERFORMANCE OPTIMIZATION BLUEPRINT: INTEL® ARCHITECTURE OPTIMIZATION WITH LARGE CODE PAGES

C.1	OVERVIEW	C-1
C.1.1	ITLBs and Stalls	C-2
C.1.2	Large Pages	C-3
C.2	DIAGNOSING THE PROBLEM	C-3
C.2.1	ITLB Misses	C-3
C.2.2	Measuring the ITLB Miss Stall	C-5
C.2.3	Source of ITLB Misses	C-6
C.3	SOLUTION	C-6
C.3.1	Linux* and Large Pages	C-6
C.3.2	Large Pages for .text	C-7
C.3.3	Reference Code	C-7
C.3.4	Large Pages for the Heap	C-8
C.4	SOLUTION INTEGRATION	C-9
C.4.1	V8 Integration with the Reference Implementation	C-9
C.4.2	JAVA JVM Integration with the Reference Implementation	C-9
C.5	LIMITATIONS	C-10
C.6	CASE STUDY	C-10
C.6.1	Ghost.js Workload	C-11
C.6.2	Web Tooling Workload	C-11
C.6.2.1	Node Version	C-11
C.6.2.2	Web Tooling	C-11
C.6.2.3	Comparing Clear Linux* OS and Ubuntu*	C-11
C.6.3	MediaWiki Workload	C-12
C.6.4	Visualization of Benefits	C-13
C.6.4.1	Precise Events	C-13
C.6.4.2	Visualizing Precise ITLB Miss	C-13
C.7	SUMMARY	C-16
C.8	TEST CONFIGURATION DETAILS	C-16
C.9	ADDITIONAL REFERENCES	C-17

APPENDIX D INSTRUCTION LATENCY AND THROUGHPUT

D.1	OVERVIEW	D-1
D.2	DEFINITIONS	D-2
D.3	LATENCY AND THROUGHPUT	D-2
D.3.1	Latency and Throughput with Register Operands	D-3
D.3.2	Table Footnotes	D-18
D.3.3	Instructions with Memory Operands	D-19
D.3.3.1	Software Observable Latency of Memory References	D-19

APPENDIX E EARLIER GENERATIONS OF INTEL® 64 AND IA-32 PROCESSOR ARCHITECTURES

E.1	HASWELL MICROARCHITECTURE	E-1
E.1.1	The Front End	E-2
E.1.2	The Out-of-Order Engine	E-2
E.1.3	Execution Engine	E-3
E.1.4	Cache and Memory Subsystem	E-5
E.1.4.1	Load and Store Operation Enhancements	E-6
E.1.5	Unlamination	E-6
E.1.6	Haswell-E Microarchitecture	E-7
E.1.7	Broadwell Microarchitecture	E-7
E.2	SANDY BRIDGE MICROARCHITECTURE	E-8
E.2.1	Sandy Bridge Microarchitecture Pipeline Overview	E-9
E.2.2	The Front End	E-10
E.2.2.1	Legacy Decode Pipeline	E-10
E.2.2.2	Decoded ICache	E-12
E.2.2.3	Branch Prediction	E-13
E.2.2.4	Micro-op Queue and the Loop Stream Detector (LSD)	E-14
E.2.3	The Out-of-Order Engine	E-14
E.2.3.1	Renamer	E-15
E.2.3.2	Scheduler	E-16
E.2.4	The Execution Core	E-16
E.2.5	Cache Hierarchy	E-17
E.2.5.1	Load and Store Operation Overview	E-18
E.2.5.2	L1 DCache	E-19
E.2.5.3	Ring Interconnect and Last Level Cache	E-23
E.2.5.4	Data Prefetching	E-24
E.2.6	System Agent	E-25
E.2.7	Ivy Bridge Microarchitecture	E-26
E.3	INTEL® CORE™ MICROARCHITECTURE AND ENHANCED INTEL® CORE™ MICROARCHITECTURE	E-26
E.3.1	Intel® Core™ Microarchitecture Pipeline Overview	E-27
E.3.2	Front End	E-28
E.3.2.1	Branch Prediction Unit	E-29
E.3.2.2	Instruction Fetch Unit	E-29
E.3.2.3	Instruction Queue (IQ)	E-30
E.3.2.4	Instruction Decode	E-31
E.3.2.5	Stack Pointer Tracker	E-31
E.3.2.6	Micro-fusion	E-31
E.3.3	Execution Core	E-31
E.3.3.1	Issue Ports and Execution Units	E-32
E.3.4	Intel® Advanced Memory Access	E-34
E.3.4.1	Loads and Stores	E-35
E.3.4.2	Data Prefetch to L1 caches	E-36
E.3.4.3	Data Prefetch Logic	E-36
E.3.4.4	Store Forwarding	E-37
E.3.4.5	Memory Disambiguation	E-38
E.3.5	Intel® Advanced Smart Cache	E-38
E.3.5.1	Loads	E-39
E.3.5.2	Stores	E-39
E.4	NEHALEM MICROARCHITECTURE	E-40
E.4.1	Microarchitecture Pipeline	E-40
E.4.2	Front End Overview	E-42

E.4.3	Execution Engine	E-43
E.4.3.1	Issue Ports and Execution Units	E-44
E.4.4	Cache and Memory Subsystem	E-45
E.4.5	Load and Store Operation Enhancements	E-46
E.4.5.1	Efficient Handling of Alignment Hazards	E-46
E.4.5.2	Store Forwarding Enhancement	E-46
E.4.6	REP String Enhancement	E-48
E.4.7	Enhancements for System Software	E-49
E.4.8	Efficiency Enhancements for Power Consumption	E-49
E.4.9	Hyper-Threading Technology Support in Nehalem Microarchitecture	E-49

APPENDIX F EARLIER GENERATIONS OF INTEL ATOM® MICROARCHITECTURE AND SOFTWARE OPTIMIZATION

F.1	OVERVIEW	F-1
F.2	INTEL ATOM® MICROARCHITECTURE	F-1
F.2.1	Hyper-Threading Technology Support in Intel Atom® Microarchitecture	F-3
F.3	CODING RECOMMENDATIONS FOR INTEL ATOM® MICROARCHITECTURE	F-3
F.3.1	Optimization for Front End of Intel Atom® Microarchitecture	F-3
F.3.2	Optimizing the Execution Core	F-5
F.3.2.1	Integer Instruction Selection	F-5
F.3.2.2	Address Generation	F-6
F.3.2.3	Integer Multiply	F-6
F.3.2.4	Integer Shift Instructions	F-7
F.3.2.5	Partial Register Access	F-7
F.3.2.6	FP/SIMD Instruction Selection	F-7
F.3.3	Optimizing Memory Access	F-9
F.3.3.1	Store Forwarding	F-9
F.3.3.2	First-level Data Cache	F-9
F.3.3.3	Segment Base	F-10
F.3.3.4	String Moves	F-10
F.3.3.5	Parameter Passing	F-11
F.3.3.6	Function Calls	F-11
F.3.3.7	Optimization of Multiply/Add Dependent Chains	F-11
F.3.3.8	Position Independent Code	F-13
F.4	INSTRUCTION LATENCY	F-13
F.5	SILVERMONT MICROARCHITECTURE	F-19
F.5.1	Integer Pipeline	F-22
F.5.2	Floating-Point Pipeline	F-22
F.6	GOLDMONT MICROARCHITECTURE	F-23
F.7	GOLDMONT PLUS MICROARCHITECTURE	F-26
F.8	CODING RECOMMENDATIONS	F-29
F.8.1	Optimizing The Front End	F-29
F.8.1.1	Instruction Decoder	F-29
F.8.1.2	Front End High IPC Considerations	F-30
F.8.1.3	Branching Across 4GB Boundary	F-31
F.8.1.4	Loop Unrolling and Loop Stream Detector	F-31
F.8.1.5	Mixing Code and Data	F-32
F.8.2	Optimizing The Execution Core	F-32
F.8.2.1	Scheduling	F-32
F.8.2.2	Address Generation	F-32
F.8.2.3	FP Multiply-Accumulate-Store Execution	F-32
F.8.2.4	Integer Multiply Execution	F-33
F.8.2.5	Zeroing Idioms	F-34
F.8.2.6	NOP Idioms	F-34
F.8.2.7	Move Elimination and ESP Folding	F-34
F.8.2.8	Stack Manipulation Instruction	F-35
F.8.2.9	Flags usage	F-35
F.8.2.10	SIMD Floating-Point and X87 Instructions	F-35
F.8.2.11	SIMD Integer Instructions	F-35
F.8.2.12	Vectorization Considerations	F-36
F.8.2.13	Other SIMD Instructions	F-36
F.8.2.14	Instruction Selection	F-36

F.8.2.15	Integer Division.....	F-38
F.8.2.16	Integer Shift.....	F-39
F.8.2.17	Pause Instruction.....	F-39
F.8.3	Optimizing Memory Accesses.....	F-39
F.8.3.1	Reduce Unaligned Memory Access with PALIGNR.....	F-39
F.8.3.2	Minimize Memory Execution Issues.....	F-40
F.8.3.3	Store Forwarding.....	F-40
F.8.3.4	PrefetchW Instruction.....	F-41
F.8.3.5	Cache Line Splits and Alignment.....	F-41
F.8.3.6	Segment Base.....	F-41
F.8.3.7	Copy and String Copy.....	F-42
F.9	INSTRUCTION LATENCY AND THROUGHPUT.....	F-42

Example 2-1.	Class 0 Pseudo-code Snippet	2-4
Example 2-2.	Class 1 Pseudo-code Snippet	2-4
Example 2-3.	Class 2 Pseudo-code Snippet	2-5
Example 2-4.	Class 3 Pseudo-code Snippet	2-5
Example 2-5.	Breaking False Dependency through Zero Idiom	2-13
Example 2-6.	Considering Stores	2-19
Example 2-7.	Rearranging Code to Achieve Store Pairing	2-19
Example 2-8.	Dynamic Pause Loop Example	2-33
Example 2-9.	Contented Locks with Increasing Back-off Example	2-34
Example 3-1.	Assembly Code with an Unpredictable Branch	3-5
Example 3-2.	Code Optimization to Eliminate Branches	3-5
Example 3-3.	Eliminating Branch with CMOV Instruction	3-6
Example 3-4.	Static Branch Prediction Algorithm	3-6
Example 3-5.	Static Taken Prediction	3-7
Example 3-6.	Static Not-Taken Prediction	3-7
Example 3-7.	Indirect Branch With Two Favored Targets	3-9
Example 3-8.	A Peeling Technique to Reduce Indirect Branch Misprediction	3-10
Example 3-9.	Loop Unrolling	3-11
Example 3-10.	Macrofusion, Unsigned Iteration Count	3-14
Example 3-11.	Macrofusion, If Statement	3-14
Example 3-12.	Macrofusion, Signed Variable	3-15
Example 3-13.	Macrofusion, Signed Comparison	3-15
Example 3-14.	Additional Macrofusion Benefit in Sandy Bridge Microarchitecture	3-16
Example 3-15.	Avoiding False LCP Delays with 0xF7 Group Instructions	3-17
Example 3-16.	Independent Two-Operand LEA Example	3-21
Example 3-17.	Alternative to Three-Operand LEA	3-22
Example 3-18.	Examples of 512-bit Additions	3-23
Example 3-19.	Clearing Register to Break Dependency While Negating Array Elements	3-26
Example 3-20.	Spill Scheduling Code	3-28
Example 3-21.	Zero-Latency MOV Instructions	3-29
Example 3-22.	Byte-Granular Data Computation Technique	3-29
Example 3-23.	Re-ordering Sequence to Improve Effectiveness of Zero-Latency MOV Instructions	3-30
Example 3-24.	Avoiding Partial Register Stalls in Integer Code	3-32
Example 3-25.	Avoiding Partial Register Stalls in SIMD Code	3-33
Example 3-26.	Avoiding Partial Flag Register Stalls	3-33
Example 3-27.	Partial Flag Register Accesses in Sandy Bridge Microarchitecture	3-34
Example 3-28.	Reference Code Template for Partially Vectorizable Program	3-36
Example 3-29.	Three Alternate Packing Methods for Avoiding Store Forwarding Difficulty	3-37
Example 3-30.	Using Four Registers to Reduce Memory Spills and Simplify Result Passing	3-37
Example 3-31.	Stack Optimization Technique to Simplify Parameter Passing	3-38
Example 3-32.	Base Line Code Sequence to Estimate Loop Overhead	3-39
Example 3-33.	Optimizing for Load Port Bandwidth in Sandy Bridge Microarchitecture	3-41
Example 3-34.	Index versus Pointers in Pointer-Chasing Code	3-42
Example 3-35.	Example of Bank Conflicts in L1D Cache and Remedy	3-43
Example 3-36.	Using XMM Register in Lieu of Memory for Register Spills	3-44
Example 3-37.	Loads Blocked by Stores of Unknown Address	3-45
Example 3-38.	Situations Showing Small Loads After Large Store	3-46
Example 3-39.	Non-forwarding Example of Large Load After Small Store	3-46
Example 3-40.	A Non-forwarding Situation in Compiler Generated Code	3-47
Example 3-41.	Two Ways to Avoid Non-forwarding Situation in Example 3-40	3-47
Example 3-42.	Large and Small Load Stalls	3-47
Example 3-43.	Loop-carried Dependence Chain	3-49
Example 3-44.	Rearranging a Data Structure	3-49
Example 3-45.	Decomposing an Array	3-50
Example 3-46.	Examples of Dynamical Stack Alignment	3-51
Example 3-47.	Instruction Pointer Query Techniques	3-53
Example 3-48.	Using Non-temporal Stores and 64-byte Bus Write Transactions	3-55
Example 3-49.	On-temporal Stores and Partial Bus Write Transactions	3-55
Example 3-50.	Using DCU Hardware Prefetch	3-56

Example 3-51.	Avoid Causing DCU Hardware Prefetch to Fetch Un-needed Lines	3-57
Example 3-52.	Technique For Using L1 Hardware Prefetch	3-58
Example 3-53.	REP STOSD with Arbitrary Count Size and 4-Byte-Aligned Destination	3-60
Example 3-54.	Algorithm to Avoid Changing Rounding Mode	3-68
Example 3-55.	Locking Algorithm for Sapphire Rapids	3-72
Example 3-56.	Fixed Instruction Sequence with Improved Performance on Sapphire Rapids	3-75
Example 3-57.	WordPress/PHP Case Study: with and without 2GB Fix for Branch Misprediction	3-76
Example 3-58.	Identification of WAITPKG with CPUID	3-78
Example 3-59.	Code Snippet in an Asynchronous Example	3-80
Example 5-1.	Identification of MMX Technology with CPUID	5-2
Example 5-2.	Identification of SSE with CPUID	5-2
Example 5-3.	Identification of SSE2 with cpuid	5-3
Example 5-4.	Identification of SSE3 with CPUID	5-3
Example 5-5.	Identification of SSSE3 with cpuid	5-3
Example 5-6.	Identification of SSE4.1 with cpuid	5-4
Example 5-7.	Identification of SSE4.2 with cpuid	5-4
Example 5-8.	Detection of AESNI Instructions	5-5
Example 5-9.	Detection of PCLMULQDQ Instruction	5-5
Example 5-10.	Detection of AVX Instruction	5-6
Example 5-11.	Detection of VEX-Encoded AESNI Instructions	5-7
Example 5-12.	Detection of VEX-Encoded AESNI Instructions	5-7
Example 5-13.	Simple Four-Iteration Loop	5-14
Example 5-14.	Streaming SIMD Extensions Using Inlined Assembly Encoding	5-14
Example 5-15.	Simple Four-Iteration Loop Coded with Intrinsics	5-15
Example 5-16.	C++ Code Using the Vector Classes	5-16
Example 5-17.	Automatic Vectorization for a Simple Loop	5-16
Example 5-18.	C Algorithm for 64-bit Data Alignment	5-18
Example 5-19.	AoS Data Structure	5-21
Example 5-20.	SoA Data Structure	5-21
Example 5-21.	AoS and SoA Code Samples	5-21
Example 5-22.	Hybrid SoA Data Structure	5-22
Example 5-23.	Pseudo-code Before Strip Mining	5-23
Example 5-24.	Strip Mined Code	5-24
Example 5-25.	Loop Blocking	5-24
Example 5-26.	Emulation of Conditional Moves	5-26
Example 6-1.	Resetting Register Between <code>__m64</code> and FP Data Types Code	6-3
Example 6-2.	FIR Processing Example in C language Code	6-4
Example 6-3.	SSE2 and SSSE3 Implementation of FIR Processing Code	6-4
Example 6-4.	Zero Extend 16-bit Values into 32 Bits Using Unsigned Unpack Instructions Code	6-5
Example 6-5.	Signed Unpack Code	6-5
Example 6-6.	Interleaved Pack with Saturation Code	6-7
Example 6-7.	Interleaved Pack without Saturation Code	6-7
Example 6-8.	Unpacking Two Packed-word Sources in Non-interleaved Way Code	6-9
Example 6-9.	PEXTRW Instruction Code	6-10
Example 6-10.	PINSRW Instruction Code	6-10
Example 6-11.	Repeated PINSRW Instruction Code	6-11
Example 6-12.	Non-Unit Stride Load/Store Using SSE4.1 Instructions	6-11
Example 6-13.	Scatter and Gather Operations Using SSE4.1 Instructions	6-11
Example 6-14.	PMOVMASKB Instruction Code	6-12
Example 6-15.	Broadcast a Word Across XMM, Using 2 SSE2 Instructions	6-13
Example 6-16.	Swap/Reverse words in an XMM, Using 3 SSE2 Instructions	6-13
Example 6-17.	Generating Constants	6-15
Example 6-18.	Absolute Difference of Two Unsigned Numbers	6-15
Example 6-19.	Absolute Difference of Signed Numbers	6-16
Example 6-20.	Computing Absolute Value	6-16
Example 6-21.	Basic C Implementation of RGBA to BGRA Conversion	6-17
Example 6-22.	Color Pixel Format Conversion Using SSE2	6-17
Example 6-23.	Color Pixel Format Conversion Using SSSE3	6-18
Example 6-24.	Big-Endian to Little-Endian Conversion	6-19

Example 6-25.	Clipping to a Signed Range of Words [High, Low]	6-20
Example 6-26.	Clipping to an Arbitrary Signed Range [High, Low]	6-20
Example 6-27.	Simplified Clipping to an Arbitrary Signed Range	6-20
Example 6-28.	Clipping to an Arbitrary Unsigned Range [High, Low]	6-21
Example 6-29.	Complex Multiply by a Constant	6-23
Example 6-30.	Using PTEST to Separate Vectorizable and non-Vectorizable Loop Iterations	6-24
Example 6-31.	Using Variable BLEND to Vectorize Heterogeneous Loops	6-24
Example 6-32.	Baseline C Code for Mandelbrot Set Map Evaluation	6-25
Example 6-33.	Vectorized Mandelbrot Set Map Evaluation Using SSE4.1 Intrinsics	6-26
Example 6-34.	A Large Load after a Series of Small Stores (Penalty)	6-28
Example 6-35.	Accessing Data Without Delay	6-28
Example 6-36.	A Series of Small Loads After a Large Store	6-28
Example 6-37.	Eliminating Delay for a Series of Small Loads after a Large Store	6-29
Example 6-38.	Un-optimized Reverse Memory Copy in C	6-30
Example 6-39.	Using PSHUFB to Reverse Byte Ordering 16 Bytes at a Time	6-32
Example 6-40.	PMOVSX/PMOVZX Work-around to Avoid False Dependency	6-34
Example 6-41.	Table Look-up Operations in C Code	6-34
Example 6-42.	Shift Techniques on Non-Vectorizable Table Look-up	6-35
Example 6-43.	PEXTRD Techniques on Non-Vectorizable Table Look-up	6-36
Example 6-44.	Pseudo-Code Flow of AES Counter Mode Operation	6-37
Example 6-45.	AES128-CTR Implementation with Eight Block in Parallel	6-38
Example 6-46.	AES128 Key Expansion	6-45
Example 6-47.	Compress 32-bit Integers into 5-bit Buckets	6-48
Example 6-48.	Decompression of a Stream of 5-bit Integers into 32-bit Elements	6-50
Example 7-1.	Pseudocode for Horizontal (xyz, AoS) Computation	7-4
Example 7-2.	Pseudocode for Vertical (xxxx, yyyy, zzzz, SoA) Computation	7-5
Example 7-3.	Swizzling Data Using SHUFPS, MOVLHPS, MOVHLPS	7-5
Example 7-4.	Swizzling Data Using UNPCKxxx Instructions	7-6
Example 7-5.	Deswizzling Single-Precision SIMD Data	7-7
Example 7-6.	Deswizzling Data Using SIMD Integer Instructions	7-8
Example 7-7.	Horizontal Add Using MOVHLPS/MOVLHPS	7-9
Example 7-8.	Horizontal Add Using Intrinsics with MOVHLPS/MOVLHPS	7-10
Example 7-9.	Multiplication of Two Pairs of Single-Precision Complex Number	7-12
Example 7-10.	Division of Two Pairs of Single-Precision Complex Numbers	7-12
Example 7-11.	Double-Precision Complex Multiplication of Two Pairs	7-13
Example 7-12.	Double-Precision Complex Multiplication Using Scalar SSE2	7-13
Example 7-13.	Dot Product of Vector Length 4 Using SSE/SSE2	7-14
Example 7-14.	Dot Product of Vector Length 4 Using SSE3	7-15
Example 7-15.	Dot Product of Vector Length 4 Using SSE4.1	7-15
Example 7-16.	Unrolled Implementation of Four Dot Products	7-15
Example 7-17.	Normalization of an Array of Vectors	7-16
Example 7-18.	Normalize (x, y, z) Components of an Array of Vectors Using SSE2	7-17
Example 7-19.	Normalize (x, y, z) Components of an Array of Vectors Using SSE4.1	7-18
Example 7-20.	Data Organization in Memory for AOS Vector-Matrix Multiplication	7-19
Example 7-21.	AOS Vector-Matrix Multiplication with HADDPS	7-19
Example 7-22.	AOS Vector-Matrix Multiplication with DPPS	7-20
Example 7-23.	Data Organization in Memory for SOA Vector-Matrix Multiplication	7-21
Example 7-24.	Vector-Matrix Multiplication with Native SOA Data Layout	7-22
Example 8-1.	VPDPBUSD Implementation	8-3
Example 8-2.	Quantization of Activations	8-5
Example 8-3.	Direct Convolution	8-10
Example 8-4.	Convolution for Layers with Low OFM Count	8-14
Example 8-5.	Basic PostConv	8-16
Example 8-6.	Uint8 Residual Input	8-17
Example 8-7.	8x8 Average Pooling with Stride 1 of 8x8 Layers	8-18
Example 8-8.	Unfused Vectorized Pooling	8-18
Example 8-9.	Caffe Scalar Code for Pixel Shuffler	8-20
Example 8-10.	Computing Output Offset for Fused Pixel Shuffler	8-21
Example 8-11.	Sigmoid Approximation with Minimax Polynomials	8-22

Example 8-12.	Sigmoid Approximation with scalef	8-23
Example 8-13.	Pseudocode for Finding Top K	8-25
Example 9-1.	Pseudo-code Using CLFLUSH	9-9
Example 9-2.	Flushing Cache Lines Using CLFLUSH or CLFLUSHOPT	9-12
Example 9-3.	Populating an Array for Circular Pointer Chasing with Constant Stride	9-13
Example 9-4.	Prefetch Scheduling Distance	9-16
Example 9-5.	Using Prefetch Concatenation	9-17
Example 9-6.	Concatenation and Unrolling the Last Iteration of Inner Loop	9-17
Example 9-8.	Data Access of a 3D Geometry Engine with Strip-mining	9-22
Example 9-7.	Data Access of a 3D Geometry Engine without Strip-mining	9-22
Example 9-9.	Using HW Prefetch to Improve Read-Once Memory Traffic	9-23
Example 9-10.	Basic Algorithm of a Simple Memory Copy	9-27
Example 9-11.	A Memory Copy Routine Using Software Prefetch	9-28
Example 9-12.	Memory Copy Using Hardware Prefetch and Bus Segmentation	9-29
Example 11-1.	Serial Execution of Producer and Consumer Work Items	11-5
Example 11-2.	Basic Structure of Implementing Producer Consumer Threads	11-6
Example 11-3.	Thread Function for an Interlaced Producer Consumer Model	11-7
Example 11-4.	Spin-wait Loop and PAUSE Instructions	11-12
Example 11-5.	Coding Pitfall using Spin Wait Loop	11-14
Example 11-6.	Placement of Synchronization and Regular Variables	11-15
Example 11-7.	Declaring Synchronization Variables without Sharing a Cache Line	11-16
Example 11-8.	Batched Implementation of the Producer Consumer Threads	11-20
Example 11-9.	Parallel Memory Initialization Technique Using OpenMP and NUMA	11-24
Example 13-1.	Compute 64-bit Quotient and Remainder with 64-bit Divisor	13-3
Example 13-2.	Quotient and Remainder of 128-bit Dividend with 64-bit Divisor	13-4
Example 14-1.	A Hash Function Examples	14-4
Example 14-2.	Hash Function Using CRC32	14-4
Example 14-3.	Strlen() Using General-Purpose Instructions	14-6
Example 14-4.	Sub-optimal PCMPISTRI Implementation of EOS handling	14-8
Example 14-5.	Strlen() Using PCMPISTRI without Loop-Carry Dependency	14-8
Example 14-6.	WordCnt() Using C and Byte-Scanning Technique	14-9
Example 14-7.	WordCnt() Using PCMPISTRM	14-10
Example 14-8.	KMP Substring Search in C	14-12
Example 14-9.	Brute-Force Substring Search Using PCMPISTRI Intrinsic	14-13
Example 14-10.	Substring Search Using PCMPISTRI and KMP Overlap Table	14-15
Example 14-11.	I Equivalent Strtok_s() Using PCMPISTRI Intrinsic	14-19
Example 14-12.	I Equivalent Strupr() Using PCMPISTRM Intrinsic	14-21
Example 14-13.	UTF16 VerStrlen() Using C and Table Lookup Technique	14-22
Example 14-14.	Assembly Listings of UTF16 VerStrlen() Using PCMPISTRI	14-23
Example 14-15.	Intrinsic Listings of UTF16 VerStrlen() Using PCMPISTRI	14-25
Example 14-16.	Replacement String Library Strcmp Using SSE4.2	14-27
Example 14-17.	High-level flow of Character Subset Validation for String Conversion	14-29
Example 14-18.	Intrinsic Listings of atol() Replacement Using PCMPISTRI	14-29
Example 14-19.	Auxiliary Routines and Data Constants Used in sse4i_atol() listing	14-31
Example 14-20.	Conversion of 64-bit Integer to ASCII	14-34
Example 14-21.	Conversion of 64-bit Integer to ASCII without Integer Division	14-35
Example 14-22.	Conversion of 64-bit Integer to ASCII Using SSE4	14-37
Example 14-23.	Conversion of 64-bit Integer to Wide Character String Using SSE4	14-43
Example 14-24.	MULX and Carry Chain in Large Integer Numeric	14-48
Example 14-25.	Building-block Macro Used in Binary Decimal Floating-point Operations	14-49
Example 15-1.	Cartesian Coordinate Transformation with Intrinsics	15-3
Example 15-2.	Cartesian Coordinate Transformation with Assembly	15-4
Example 15-3.	Direct Polynomial Calculation	15-6
Example 15-4.	Function Calls and AVX/SSE transitions	15-10
Example 15-5.	AoS to SoA Conversion of Complex Numbers in C Code	15-12
Example 15-6.	Aos to SoA Conversion of Complex Numbers Using AVX	15-13
Example 15-7.	Register Overlap Method for Median of 3 Numbers	15-15
Example 15-8.	Data Gather - AVX versus Scalar Code	15-17
Example 15-9.	Scatter Operation Using AVX	15-18

Example 15-10.	SAXPY using Intel AVX	15-20
Example 15-11.	Using 16-Byte Memory Operations for Unaligned 32-Byte Memory Operation	15-21
Example 15-12.	SAXPY Implementations for Unaligned Data Addresses	15-21
Example 15-13.	Loop with Conditional Expression	15-25
Example 15-14.	Handling Loop Conditional with VMASKMOV	15-25
Example 15-15.	Three-Tap Filter in C Code	15-26
Example 15-16.	Three-Tap Filter with 128-bit Mixed Integer and FP SIMD	15-26
Example 15-17.	256-bit AVX Three-Tap Filter Code with VSHUFPS	15-27
Example 15-18.	Three-Tap Filter Code with Mixed 256-bit AVX and 128-bit AVX Code	15-28
Example 15-19.	8x8 Matrix Transpose - Replace Shuffles with Blends	15-30
Example 15-20.	8x8 Matrix Transpose Using VINSERTPS	15-33
Example 15-21.	Port 5 versus Load Port Shuffles	15-35
Example 15-22.	Divide Using DIVPS for 24-bit Accuracy	15-37
Example 15-23.	Divide Using RCPPS 11-bit Approximation	15-38
Example 15-24.	Divide Using RCPPS and Newton-Raphson Iteration	15-38
Example 15-25.	Reciprocal Square Root Using DIVPS+SQRTPS for 24-bit Accuracy	15-39
Example 15-26.	Reciprocal Square Root Using RSQRTPS 11-bit Approximation	15-39
Example 15-27.	Reciprocal Square Root Using RSQRTPS and Newton-Raphson Iteration	15-40
Example 15-28.	Square Root Using SQRTPS for 24-bit Accuracy	15-41
Example 15-29.	Square Root Using RSQRTPS 11-bit Approximation	15-41
Example 15-30.	Square Root Using RSQRTPS and One Taylor Series Expansion	15-42
Example 15-31.	Array Sub Sums Algorithm	15-44
Example 15-32.	Single-Precision to Half-Precision Conversion	15-45
Example 15-33.	Half-Precision to Single-Precision Conversion	15-46
Example 15-34.	Performance Comparison of Median3 using Half-Precision vs. Single-Precision	15-47
Example 15-35.	FP Mul/FP Add Versus FMA	15-48
Example 15-36.	Unrolling to Hide Dependent FP Add Latency	15-49
Example 15-37.	FP Mul/FP Add Versus FMA	15-50
Example 15-38.	Macros for Separable KLT Intra-block Transformation Using AVX2	15-51
Example 15-39.	Separable KLT Intra-block Transformation Using AVX2	15-53
Example 15-40.	Macros for Parallel Moduli/Remainder Calculation	15-59
Example 15-41.	Signed 64-bit Integer Conversion Utility	15-60
Example 15-42.	Unsigned 63-bit Integer Conversion Utility	15-61
Example 15-43.	Access Patterns Favoring Non-VGATHER Techniques	15-65
Example 15-44.	Access Patterns Likely to Favor VGATHER Techniques	15-66
Example 15-45.	Software AVX Sequence Equivalent to Full-Mask VPGATHERD	15-67
Example 15-46.	AOS to SOA Transformation Alternatives	15-69
Example 15-47.	Non-Strided AOS to SOA	15-70
Example 15-48.	Conversion to Throughput-Reduced MMX sequence to AVX2 Alternative	15-72
Example 16-1.	Reduce Data Conflict with Conditional Updates	16-6
Example 16-2.	Transition from Non-Elided Execution without Aborting	16-10
Example 16-3.	Exemplary Wrapper Using RTM for Lock/Unlock Primitives	16-12
Example 16-4.	Spin Lock Example Using HLE in GCC 4.8 and Later	16-14
Example 16-5.	Spin Lock Example Using HLE in Intel and Microsoft Compiler Intrinsic	16-14
Example 16-6.	A Meta Lock Example	16-16
Example 16-7.	A Meta Lock Example Using RTM	16-17
Example 16-8.	HLE-enabled Lock-Acquire/ Lock-Release Sequence	16-18
Example 16-9.	A Spin Wait Example Using HLE	16-19
Example 16-10.	A Conceptual Example of Intermixed HLE and RTM	16-20
Example 16-11.	Emulated RTM intrinsic for Older GCC compilers	16-27
Example 16-12.	C++ Example of HLE Intrinsic	16-29
Example 16-13.	Emulated HLE Intrinsic with Older GCC compiler	16-29
Example 16-14.	HLE Intrinsic Supported by Intel and Microsoft Compilers	16-30
Example 17-1.	Unoptimized Sleep Loop	17-14
Example 17-2.	Power Consumption Friendly Sleep Loop Using PAUSE	17-14
Example 18-1.	Cartesian Coordinate System Rotation with Intrinsics	18-3
Example 18-2.	Cartesian Coordinate System Rotation with Assembly	18-5
Example 18-3.	Masking with Intrinsics	18-9
Example 18-4.	Masking with Assembly	18-9

Example 18-5.	Masking Example	18-11
Example 18-6.	Masking vs. Blending Example 1	18-12
Example 18-7.	Masking vs. Blending Example 2	18-13
Example 18-8.	Multiple Condition Execution	18-14
Example 18-9.	Peeling and Remainder Masking	18-15
Example 18-10.	Comparing Intel® AVX-512 Data Compress with Other Alternatives	18-19
Example 18-11.	Comparing Intel® AVX-512 Data Expand Operation with Other Alternatives	18-24
Example 18-12.	Comparing Ternary Logic to Other Alternatives	18-26
Example 18-13.	Matrix Transpose Alternatives	18-31
Example 18-14.	Broadcast Executed on Load Ports Alternatives	18-32
Example 18-15.	16-bit Broadcast Executed on Port 5	18-33
Example 18-16.	Embedded vs Non-embedded Rounding	18-34
Example 18-17.	Scatter	18-36
Example 18-18.	QWORD Example, Intel® AVX2 vs. Intel® AVX-512	18-39
Example 18-19.	Scatter Implementation Alternatives	18-50
Example 18-20.	Scalar vs. Vector Update Using AVX-512CD	18-53
Example 18-21.	Improvement with VPERMB Implementation	18-55
Example 18-22.	Improvement with VPERMI2B Implementation	18-57
Example 18-23.	Improvement with VPMULTISHIFTQB Implementation	18-59
Example 18-24.	256-bit Code vs. 256-bit Code Mixed with 512-bit Code	18-63
Example 18-25.	Identifying One or Two FMA Units in a Processor Based on Skylake Microarchitecture	18-64
Example 18-26.	Gather to Shuffle in Strided Loads Example	18-68
Example 18-27.	Gather to Shuffle in Strided Stores Example	18-69
Example 18-28.	Gather to Shuffle in Adjacent Loads Example	18-71
Example 18-29.	Data Alignment	18-72
Example 18-30.	Vectorized 32-bit Float Division	18-78
Example 18-31.	Reciprocal Square Root	18-79
Example 18-32.	Square Root	18-80
Example 18-33.	Dividing Packed Doubles	18-81
Example 18-34.	Reciprocal Square Root of Doubles	18-82
Example 18-35.	Square Root of Packed Doubles	18-83
Example 19-1.	Function for Converting from a Complex-Valued Mask To a Real-Valued Mask by Duplicating Adjacent Bits	19-8
Example 19-2.	Function for Converting from a Real-Valued Mask to a Complex-Valued Mask By AND-Combining Adjacent Bits	19-9
Example 19-3.	Function for Converting from a Real-Valued Mask To a Complex-Valued Mask By OR-Combining Adjacent Bits	19-9
Example 19-4.	Function to Implement the 16-Bit Compress Operation on FP16 Vector Elements	19-17
Example 19-5.	Function That Performs Fast Floating-Point Minimum Using Integer Instructions	19-19
Example 20-1.	Pseudo-code for the Tilezero, TileLoad, and TileStore Instructions	20-6
Example 20-2.	B Matrix Re-layout Procedure	20-6
Example 20-3.	Common Defines	20-8
Example 20-4.	Reference GEMM Implementation	20-9
Example 20-5.	K-dimension Loop as Innermost Loop—A highly inefficient approach	20-10
Example 20-6.	Innermost Loop Tile Pre-loading	20-11
Example 20-7.	Switched Order of M_ACC and N_ACC Loops	20-11
Example 20-8.	Optimized GEMM implementation	20-12
Example 20-9.	Dimension of matrices, data types and tile sizes	20-13
Example 20-10.	Optimized GEMM Assembly Language Implementation	20-14
Example 20-11.	Activations Layout Procedure	20-15
Example 20-12.	Weights Re-Layout Procedure	20-16
Example 20-13.	Common Defines for Convolution	20-19
Example 20-14.	Optimized direct convolution implementation	20-20
Example 20-15.	Additional Defines for Convolution with Cache Blocking	20-21
Example 20-16.	Optimized Convolution Implementation with Cache Blocking	20-22
Example 20-17.	Optimized Convolution Implementation with Cache Blocking	20-30
Example 20-18.	Example of a Short GEMM Fused and Pipelined with Quantization and ReLU	20-32
Example 20-19.	The conversion code for two blocks of sixteen cache lines of 32-bit floats converted to a single block of sixteen cache lines of 16-bit bfloats	20-36

Example 20-20.	Using Unsigned Saturation	20-37
Example 20-21.	Prefetching Rows to the DCU	20-40
Example 20-22.	BF16 Matrix Transpose (32x8 to 8x32)	20-42
Example 20-23.	BF16 VNNI to VNNI Transpose (8x8 to 2x32)	20-47
Example 20-24.	BF16 Flat to VNNI Transpose (16x8 to 4x32)	20-50
Example 20-25.	BF16 Flat-to-VNNI Re-Layout	20-52
Example 20-26.	GEMM Parallelized with omp Parallel for with Collapse	20-56
Example 20-27.	Byte Decompression code with Intel® AVX-512 Intrinsics	20-58
Example 20-28.	The Parameter m, n, k Identifies the Shape of the Tile	20-60
Example 20-29.	Intel® AMX Intrinsics header file	20-61
Example 20-30.	Intel® AMX Intrinsics usage	20-64
Example 20-31.	Compiler-generated assembly-level code out of example 20-30 Intrinsics code	20-65
Example 20-32.	Compiler-generated assembly-level code where tile register save/restore is optimized away	20-66
Example 21-1.	Legacy Intel® AES-NI vs. Vector AES	21-1
Example 21-2.	SM4 GFNI Encryption Round Example	21-3
Example 23-1.	Gather Comparison Between AVX-512F and AVX2	23-8
Example 23-2.	Gather Comparison Between AVX-512F and Previous Generation Equivalent	23-8
Example 23-3.	Using VRCP28SS for 32-bit Floating-Point Division	23-9
Example 23-4.	Replace VCOMIS* with VCOMPSS/KORTEST	23-11
Example 23-5.	Using Software Sequence for Horizontal Reduction	23-12
Example 23-6.	Optimized Inner Loop of DGEMM for Knights Landing Microarchitecture	23-13
Example 23-7.	Ordering of Memory Instruction for MEC	23-18
Example F-1.	Instruction Pairing and Alignment to Optimize Decode Throughput on Intel Atom® Microarchitecture	F-4
Example F-2.	Alternative to Prevent AGU and Execution Unit Dependency	F-6
Example F-3.	Pipelining Instruction Execution in Integer Computation	F-7
Example F-4.	Memory Copy of 64-byte	F-11
Example F-5.	Examples of Dependent Multiply and Add Computation	F-12
Example F-6.	Instruction Pointer Query Techniques	F-13
Example F-7.	Unrolled Loop Executes In-Order Due to Multiply-Store Port Conflict	F-33
Example F-8.	Grouping Store Instructions Eliminates Bubbles and Improves IPC	F-33

Figure 2-1.	Processor Core Pipeline Functionality of the Golden Cove Microarchitecture	2-8
Figure 2-2.	Processor Front End of the Golden Cove Microarchitecture	2-9
Figure 2-3.	Processor Core Pipeline Functionality of the Ice Lake Client Microarchitecture	2-14
Figure 2-4.	Processor Core Pipeline Functionality of the Skylake Server Microarchitecture.	2-22
Figure 2-5.	Broadwell Microarchitecture and Skylake Server Microarchitecture Cache Structures.	2-24
Figure 2-6.	Mixed Workloads	2-26
Figure 2-7.	LINPACK Performance	2-27
Figure 2-8.	CPU Core Pipeline Functionality of the Skylake Client Microarchitecture	2-28
Figure 2-9.	Hyper-Threading Technology on an SMP	2-35
Figure 2-10.	Typical SIMD Operations	2-37
Figure 2-11.	SIMD Instruction Register Usage	2-38
Figure 3-1.	Generic Program Flow of Partially Vectorized Code	3-35
Figure 3-2.	Memcpy Performance Comparison for Lengths up to 2KB.	3-62
Figure 3-3.	MariaDB - CHA % Cycles Fast Asserted.	3-73
Figure 3-4.	Identifying >2GB Branches.	3-75
Figure 4-1.	Processor Core Pipeline Functionality of the Gracemont Microarchitecture.	4-2
Figure 4-2.	Front-End Pipeline Functionality of the Gracemont Microarchitecture.	4-3
Figure 4-3.	Execution Pipeline Functionality of the Gracemont Microarchitecture.	4-6
Figure 4-4.	Processor Core Pipeline Functionality of the Tremont Microarchitecture.	4-11
Figure 5-1.	General Procedural Flow of Application Detection of AVX.	5-6
Figure 5-2.	General Procedural Flow of Application Detection of Float-16.	5-8
Figure 5-3.	Converting to Streaming SIMD Extensions Chart.	5-11
Figure 5-4.	Hand-Coded Assembly and High-Level Compiler Performance Trade-offs	5-13
Figure 5-5.	Loop Blocking Access Pattern	5-26
Figure 6-1.	PACKSSDW mm, mm/mm64 Instruction	6-6
Figure 6-2.	Interleaved Pack with Saturation.	6-7
Figure 6-3.	Result of Non-Interleaved Unpack Low in MMO.	6-8
Figure 6-4.	Result of Non-Interleaved Unpack High in MM1.	6-8
Figure 6-5.	PEXTRW Instruction	6-9
Figure 6-6.	PINSRW Instruction	6-10
Figure 6-7.	PMOVSMB Instruction	6-12
Figure 6-8.	Data Alignment of Loads and Stores in Reverse Memory Copy	6-31
Figure 6-9.	A Technique to Avoid Cacheline Split Loads in Reverse Memory Copy Using Two Aligned Loads	6-32
Figure 7-1.	Homogeneous Operation on Parallel Data Elements	7-3
Figure 7-2.	Horizontal Computation Model	7-3
Figure 7-3.	Dot Product Operation	7-4
Figure 7-4.	Horizontal Add Using MOVHLPS/MOVLHPS.	7-9
Figure 7-5.	Asymmetric Arithmetic Operation of the SSE3 Instruction	7-11
Figure 7-6.	Horizontal Arithmetic Operation of the SSE3 Instruction HADDPD.	7-11
Figure 8-1.	Matrix Layout, Inputs and Outputs.	8-7
Figure 8-2.	Transformed Weights.	8-8
Figure 8-3.	Convolution Operation	8-8
Figure 8-4.	Matrix Multiplications and Summations	8-8
Figure 8-5.	3-Tier Flexible 2D Blocking.	8-9
Figure 8-6.	3-Tier Flexible 2D Blocking Loops	8-10
Figure 8-7.	Standard vs Optimized vs. Low OFM Optimized Data Layouts	8-13
Figure 8-8.	Dynamic Batch Size.	8-24
Figure 8-9.	Find Top 16 Values in Some Input	8-24
Figure 9-1.	CLFLUSHOPT versus CLFLUSH In SkyLake Microarchitecture.	9-11
Figure 9-2.	Effective Latency Reduction as a Function of Access Stride.	9-14
Figure 9-3.	Memory Access Latency and Execution Without Prefetch.	9-14
Figure 9-4.	Memory Access Latency and Execution With Prefetch	9-15
Figure 9-5.	Prefetch and Loop Unrolling	9-18
Figure 9-6.	Memory Access Latency and Execution With Prefetch	9-18
Figure 9-7.	Spread Prefetch Instructions	9-19
Figure 9-8.	Cache Blocking - Temporally Adjacent and Non-adjacent Passes	9-20
Figure 9-9.	Examples of Prefetch and Strip-mining for Temporally Adjacent and Non-Adjacent Passes	9-21
Figure 9-10.	Single-Pass Vs. Multi-Pass 3D Geometry Engines	9-25

Figure 10-1.	Example of SNC Configuration	10-1
Figure 10-2.	NUMA Disabled	10-5
Figure 10-3.	SNC Off	10-6
Figure 10-4.	SNC On	10-7
Figure 10-5.	Domain Example with One MPI Process Per Domain	10-8
Figure 11-1.	Amdahl's Law and MP Speed-up	11-2
Figure 11-2.	Single-threaded Execution of Producer-consumer Threading Model	11-5
Figure 11-3.	Execution of Producer-consumer Threading Model on a Multicore Processor	11-5
Figure 11-4.	Interlaced Variation of the Producer Consumer Model	11-6
Figure 11-5.	Batched Approach of Producer Consumer Model	11-20
Figure 12-1.	In App Direct Mode, Data on the Intel® Optane™ DC Persistent Memory Module is Accessed Directly with Loads and Stores	12-2
Figure 12-2.	Decision Flow for Determining When to Use Intel® Optane™ DC Persistent Memory Module vs. DRAM	12-3
Figure 12-3.	Loaded Latency Curves for One Intel® Optane™ DC Persistent Memory Module DIMM: Sequential Traffic (Left) and Random Traffic (Right)	12-5
Figure 12-4.	Number of Threads vs. Bandwidth	12-6
Figure 12-5.	Combining with Two Cores	12-6
Figure 12-6.	Combining with Four Cores	12-7
Figure 12-7.	Combining with Eight Cores	12-8
Figure 12-8.	PMDK vs. MSYNC Flushing Times	12-9
Figure 12-9.	Bandwidth vs. Power Consumption	12-10
Figure 12-10.	Read-Write Equivalence for Intel® Optane™ DC Persistent Memory Module DIMMs within Different Power Budgets	12-11
Figure 12-11.	Bandwidth Available to Software when There is No Locality at 256B Granularity	12-12
Figure 14-1.	SSE4.2 String/Text Instruction Immediate Operand Control	14-2
Figure 14-2.	Retrace Inefficiency of Byte-Granular, Brute-Force Search	14-12
Figure 14-3.	SSE4.2 Speedup of SubString Searches	14-18
Figure 14-4.	Compute Four Remainders of Unsigned Short Integer in Parallel	14-37
Figure 15-1.	AVX-SSE Transitions in the Broadwell, and Prior Generation Microarchitectures	15-8
Figure 15-2.	AVX-SSE Transitions in the Skylake Microarchitecture	15-8
Figure 15-3.	4x4 Image Block Transformation	15-51
Figure 15-4.	Throughput Comparison of Gather Instructions	15-67
Figure 15-5.	Comparison of HW GATHER Versus Software Sequence in Skylake Microarchitecture	15-68
Figure 17-1.	Performance History and State Transitions	17-2
Figure 17-2.	Active Time Versus Halted Time of a Processor	17-3
Figure 17-3.	Application of C-states to Idle Time	17-4
Figure 17-4.	Profiles of Coarse Task Scheduling and Power Consumption	17-9
Figure 17-5.	Thread Migration in a Multicore Processor	17-11
Figure 17-6.	Progression to Deeper Sleep	17-11
Figure 17-7.	Energy Saving due to Performance Optimization	17-13
Figure 17-8.	Energy Saving due to Vectorization	17-13
Figure 17-9.	Energy Saving Comparison of Synchronization Primitives	17-16
Figure 17-10.	Power Saving Comparison of Power-Source-Aware Frame Rate Configurations	17-17
Figure 18-1.	Intel® AVX-512 Extensions Supported by Skylake Server Microarchitecture and Knights Landing Microarchitecture	18-1
Figure 18-2.	Cartesian Rotation	18-2
Figure 18-3.	Data Forwarding Cases	18-16
Figure 18-4.	Data Compress Operation	18-18
Figure 18-5.	Data Expand Operation	18-23
Figure 18-6.	Ternary Logic Example 1 Truth Table	18-25
Figure 18-7.	Ternary Logic Example 2 Truth Table	18-28
Figure 18-8.	VPERMI2PS Instruction Operation	18-29
Figure 18-9.	VSCATTERDPD Instruction Operation	18-35
Figure 18-10.	VPCONFLICTD Instruction Execution	18-48
Figure 18-11.	VPCONFLICTD Merging Process	18-49
Figure 18-12.	VPCONFLICTD Permute Control	18-49
Figure 18-13.	VPCONFLICTD ZMM2 Result	18-51

Figure 18-14.	Sparse Vector Example	18-51
Figure 18-15.	VPERMB Instruction Operation	18-54
Figure 18-16.	VPERMI2B Instruction Operation	18-55
Figure 18-17.	VPERMT2B Instruction Operation	18-56
Figure 18-18.	VPMULTISHIFTQB Instruction Operation	18-58
Figure 18-19.	Fast Bypass When All Sources Come from FMA Unit	18-61
Figure 18-20.	Mixing Intel AVX Instructions or Intel AVX-512 Instructions with Intel SSE Instructions	18-62
Figure 19-1.	Layout of a 128-Bit Register Representing Four Complex FP16 (CFP16) Values	19-4
Figure 19-2.	Illustration of a Zero-Masked FP16 Add On Two 128-Bit Vectors	19-6
Figure 19-3.	Illustration of a Masked Complex Multiplication	19-7
Figure 19-4.	Illustration of Using a Real-Valued FP16 Vector Operation for Implementing a Masked Complex Addition	19-7
Figure 19-5.	Comparison Operation Between Two Complex-Valued Vectors. The mask bits are generated using a real-valued comparison, then adjacent bits combined using AND	19-8
Figure 19-6.	Bit Layout of Three Types of Floating-Point Formats	19-10
Figure 19-7.	Landmark Numbers on the Real-Valued FP16 Axis	19-11
Figure 19-8.	Heat-map Showing Relative ULP Error for Different Combinations of Divisor and Dividend Value Ranges	19-16
Figure 20-1.	Matrix Notation	20-4
Figure 20-2.	Intel® AMX Multiplication with Max-sized int8 Tiles	20-5
Figure 20-3.	Re-layout of 64x16 int8 B Matrix	20-7
Figure 20-4.	Re-layout of 32x16 bfloat16 B Matrix	20-7
Figure 20-5.	Activations layout	20-16
Figure 20-6.	Weights Re-Layout	20-17
Figure 20-7.	Convolution - Matrix Multiplication and Summation Equivalence	20-17
Figure 20-8.	Matrix-Like Multiplications Part of a Convolution	20-18
Figure 20-9.	Batching Execution Using Six Layers with Four Instances Per Thread	20-24
Figure 20-10.	An Example of a Convolution Elements interacting with weight element kh,kw=0,0 are highlighted	20-27
Figure 20-11.	An Example of a Convolution with Large Tiles. Elements going into each tile are highlighted differently	20-28
Figure 20-12.	Please provide Figure Description	20-34
Figure 20-13.	A Conversion Flow of 32-bit Integers to 8-bit Integers	20-36
Figure 20-14.	Trivial Deep Learning Topology with Naive Buffer Allocation	20-37
Figure 20-15.	Minimal Memory Footprint Buffer Allocation Scheme for the Trivial Deep Learning Topology	20-38
Figure 20-16.	Loading 32 Quarter-Cache Lines into 8 ZMM Registers	20-45
Figure 20-17.	The Implementation of loading eight quarter-cache lines into two ZMM registers	20-48
Figure 20-18.	Flat-to-VNNI transpose of WORDS is equivalent to Flat-to-Flat transpose of DWORDs	20-48
Figure 20-19.	BF16 Flat-to-VNNI Transpose	20-51
Figure 20-20.	GEMM Data Partitioning Between Three Cores in a Layer Partitioned by the M Dimension	20-54
Figure 20-21.	GEMM Data Partitioning Between Three Cores in a Layer Partitioned by the N-Dimension	20-54
Figure 20-22.	GEMM Data Partitioning Between Three Cores in a Layer Partitioned by the K Dimension	20-55
Figure 20-23.	A recommendation system multi-threading model	20-57
Figure 20-24.	Data Expand Operation	20-59
Figure 23-1.	Tile-Mesh Topology of the Knights Landing Microarchitecture	23-1
Figure 23-2.	Processor Core Pipeline Functionality of the Knights Landing Microarchitecture	23-2
Figure B-1.	General TMA Hierarchy for Out-of-Order Microarchitectures	B-2
Figure B-2.	TMA's Top Level Drill Down Flowchart	B-3
Figure B-3.	TMA Hierarchy and Precise Events in Skylake	B-8
Figure B-4.	System Topology Supported by Intel® Xeon® Processor 5500 Series	B-15
Figure B-5.	PMU Specific Event Logic Within the Pipeline	B-17
Figure B-6.	LBR Records and Basic Blocks	B-28
Figure B-7.	Using LBR Records to Rectify Skewed Sample Distribution	B-28
Figure B-8.	RdData Request after LLC Miss to Local Home (Clean Rsp)	B-39
Figure B-9.	RdData Request after LLC Miss to Remote Home (Clean Rsp)	B-39
Figure B-11.	RdData Request after LLC Miss to Local Home (Hitm Response)	B-40
Figure B-10.	RdData Request after LLC Miss to Remote Home (Hitm Response)	B-40

Figure B-12.	RdData Request after LLC Miss to Local Home (Hit Response)	B-41
Figure B-13.	RdInvOwn Request after LLC Miss to Remote Home (Clean Res)	B-41
Figure B-15.	RdInvOwn Request after LLC Miss to Local Home (Hit Res)	B-42
Figure B-14.	RdInvOwn Request after LLC Miss to Remote Home (Hitm Res)	B-42
Figure B-16.	Performance Events Drill-Down and Software Tuning Feedback Loop	B-61
Figure C-1.	ITLB Miss Stalls in Language Runtimes on Intel® Xeon® 8180 Processor	C-1
Figure C-2.	ITLB and ITLB 4K MPKI Across Runtime Workloads	C-4
Figure C-3.	measure-perf-metric.sh Tool Usage for Process ID 69772 for 30 Seconds	C-5
Figure C-4.	Using measure-perf-metric.sh with -r to Determine Where TLB Misses are Coming From	C-6
Figure C-5.	Commands for Checking Linux* Distribution for THP	C-7
Figure C-6.	API Calls Provided by the Intel Reference Implementation	C-8
Figure C-7.	perf Output Will Not Have the Proper Symbols After Large Page Mapping	C-10
Figure C-8.	Using Perf Record with -e frontend_retired.itlb_miss to Determine ITLB Misses and Running Perf Script to Obtain Data for Importing into FlameScope	C-13
Figure C-9.	Using FlameScope to Visualize the ITLB Misses Heatmap from the WebTooling Workload	C-14
Figure C-10.	Using FlameScope to Visualize the ITLB Misses Heatmap from the WebTooling Workload when Run with Large Pages	C-14
Figure C-11.	Visualizing ITLB Miss Trends for "Built-in" Functions from the Ghost.js Workload	C-15
Figure C-12.	Visualizing ITLB Miss Trends for "Built-in" Functions from the Ghost.js Workload When Run With Large Pages	C-15
Figure E-1.	CPU Core Pipeline Functionality of the Haswell Microarchitecture	E-1
Figure E-2.	Four Core System Integration of the Haswell Microarchitecture	E-2
Figure E-3.	An Example of the Haswell-E Microarchitecture Supporting 12 Processor Cores	E-7
Figure E-4.	Sandy Bridge Microarchitecture Pipeline Functionality	E-9
Figure E-5.	Intel Core Microarchitecture Pipeline Functionality	E-28
Figure E-6.	Execution Core of Intel Core Microarchitecture	E-34
Figure E-7.	Store-Forwarding Enhancements in Enhanced Intel Core Microarchitecture	E-37
Figure E-8.	Intel Advanced Smart Cache Architecture	E-38
Figure E-9.	Nehalem Microarchitecture Pipeline Functionality	E-41
Figure E-10.	Front End of Nehalem Microarchitecture	E-42
Figure E-11.	Store-Forwarding Scenarios of 16-Byte Store Operations	E-47
Figure E-12.	Store-Forwarding Enhancement in Nehalem Microarchitecture	E-48
Figure F-1.	Intel Atom® Microarchitecture Pipeline	F-2
Figure F-2.	Silvermont Microarchitecture Pipeline	F-20
Figure F-3.	CPU Core Pipeline Functionality of the Goldmont Microarchitecture	F-24
Figure F-4.	CPU Core Pipeline Functionality of the Goldmont Plus Microarchitecture	F-27

TABLES

Table 2-2.	Golden Cove Microarchitecture Execution Units and Representative Instructions	2-10
Table 2-1.	Dispatch Port and Execution Stacks of the Golden Cove Microarchitecture	2-10
Table 2-3.	Bypass Delay Between Producer and Consumer Micro-ops	2-11
Table 2-4.	Dispatch Port and Execution Stacks of the Ice Lake Client Microarchitecture	2-16
Table 2-5.	Ice Lake Client Microarchitecture Execution Units and Representative Instructions	2-16
Table 2-6.	Bypass Delay Between Producer and Consumer Micro-ops	2-17
Table 2-7.	Cache Parameters of the Ice Lake Client Microarchitecture	2-18
Table 2-8.	TLB Parameters of the Ice Lake Client Microarchitecture	2-18
Table 2-9.	Cache Comparison Between Skylake Microarchitecture and Broadwell Microarchitecture	2-23
Table 2-10.	Maximum Intel® Turbo Boost Technology Core Frequency Levels	2-25
Table 2-11.	Dispatch Port and Execution Stacks of the Skylake Client Microarchitecture	2-30
Table 2-12.	Skylake Client Microarchitecture Execution Units and Representative Instructions	2-30
Table 2-13.	Bypass Delay Between Producer and Consumer Micro-ops	2-31
Table 2-14.	Cache Parameters of the Skylake Client Microarchitecture	2-32
Table 2-15.	TLB Parameters of the Skylake Client Microarchitecture	2-32
Table 3-1.	Macro-Fusible Instructions in Sandy Bridge Microarchitecture	3-13
Table 3-2.	Macro-Fusible Instructions in Haswell Microarchitecture	3-13
Table 3-3.	Recommended Multi-Byte Sequence of NOP Instruction	3-27
Table 3-4.	Store Forwarding Restrictions of Processors Based on Intel Core Microarchitecture	3-48
Table 3-5.	Relative Performance of Memcpy() Using Enhanced REP MOVSB and STOSB Vs. 128-bit AVX	3-62
Table 3-6.	Effect of Address Misalignment on Memcpy() Performance	3-63
Table 3-7.	Intel Processor CPU RP Device IDs for Processors Optimizing PCIe Performance	3-71
Table 3-8.	Samples: 365K of events 'anon group[cpu/mem-loads-aux/,cpu/mem-loads,ldat=128/pp]', Event count (a--r0x): 67900852	3-72
Table 3-9.	Instruction Sequence Mixing VEX and Legacy on Sapphire Rapids and ICX	3-74
Table 4-1.	Paging Cache Parameters of the Gracemont Microarchitecture	4-7
Table 4-2.	Dispatch Port and Execution Stacks of the Tremont Microarchitecture	4-12
Table 4-3.	Cache Parameters of the Tremont Microarchitecture	4-13
Table 6-1.	PSHUF Encoding	6-13
Table 7-1.	SoA Form of Representing Vertices Data	7-4
Table 9-1.	Implementation Details of Prefetch Hint Instructions	9-4
Table 9-2.	Software Prefetching Considerations into Strip-mining Code	9-23
Table 9-3.	Deterministic Cache Parameters Leaf	9-31
Table 11-1.	Properties of Synchronization Objects	11-11
Table 11-2.	Design-Time Resource Management Choices	11-22
Table 11-3.	Microarchitectural Resources Comparisons of HT Implementations	11-25
Table 12-1.	Latencies for Accessing Intel® Optane™ DC Persistent Memory Modules	12-4
Table 12-2.	Bandwidths per DIMM for Intel® Optane™ DC Persistent Memory Modules and DRAM	12-4
Table 14-1.	SSE4.2 String/Text Instructions Compare Operation on N-elements	14-2
Table 14-2.	SSE4.2 String/Text Instructions Unary Transformation on IntRes1	14-3
Table 14-3.	SSE4.2 String/Text Instructions Output Selection Imm[6]	14-3
Table 14-4.	SSE4.2 String/Text Instructions Element-Pair Comparison Definition	14-3
Table 14-5.	SSE4.2 String/Text Instructions Eflags Behavior	14-3
Table 15-1.	Features between 256-bit AVX, 128-bit AVX and Legacy SSE Extensions	15-2
Table 15-2.	State Transitions of Mixing AVX and SSE Code	15-9
Table 15-3.	Approximate Magnitude of AVX-SSE Transition Penalties in Different Microarchitectures	15-9
Table 15-4.	Effect of VZEROUPPER with Inter-Function Calls Between AVX and SSE Code	15-10
Table 15-5.	Comparison of Numeric Alternatives of Selected Linear Algebra in Skylake Microarchitecture ..	15-36
Table 15-6.	Single-Precision Divide and Square Root Alternatives	15-36
Table 15-7.	Comparison of AOS to SOA with Strided Access Pattern	15-69
Table 15-8.	Comparison of Indexed AOS to SOA Transformation	15-71
Table 16-1.	RTM Abort Status Definition	16-23
Table 17-1.	ACPI C-State Type Mappings to Processor Specific C-State for Mobile Processors Based on Nehalem Microarchitecture17-5	
Table 17-2.	ACPI C-State Type Mappings to Processor Specific C-State of Sandy Bridge Microarchitecture ..	17-5
Table 17-3.	C-State Total Processor Exit Latency for Client Systems (Core+ Package Exit Latency) with Slow VR17-18	

Table 17-4.	C-State Total Processor Exit Latency for Client Systems (Core+ Package Exit Latency) with Fast VR	17-18
Table 17-5.	C-State Core-Only Exit Latency for Client Systems with Slow VR.....	17-19
Table 17-6.	POWER_CTL MSR in Processors Based on Sandy Bridge Microarchitecture	17-19
Table 18-1.	Cache Comparison Between Skylake Server Microarchitecture and Broadwell Microarchitecture.....	18-14
Table 18-2.	Static Rounding Mode Functions.....	18-34
Table 18-3.	Vector Quadword Extensions.....	18-42
Table 18-4.	Scalar Quadword Extensions	18-42
Table 18-5.	Vector Quadword Extensions.....	18-43
Table 18-6.	Scalar Quadword Extensions	18-43
Table 18-7.	FMA Unit Latency.....	18-61
Table 18-8.	Data Alignment Effects on SAXPY Performance vs. Speedup Value.....	18-72
Table 18-9.	Skylake Microarchitecture Recommendations for DIV/SQRT Based Operations (Single Precision)	18-74
Table 18-10.	Skylake Microarchitecture Recommendations for DIV/SQRT Based Operations (Double Precision).....	18-74
Table 18-11.	256-bit Intel AVX2 Divide and Square Root Instruction Performance	18-75
Table 18-12.	512-bit Intel AVX-512 Divide and Square Root Instruction Performance.....	18-75
Table 18-13.	Latency/Throughput of Different Methods of Computing Divide and Square Root on Skylake Microarchitecture for Different Vector Widths, on Single Precision	18-76
Table 18-14.	Latency/Throughput of Different Methods of Computing Divide and Square Root on Skylake Microarchitecture for Different Vector Widths, on Double Precision.....	18-77
Table 19-1.	Terminology.....	19-1
Table 19-2.	Supported FP16 Data Types	19-3
Table 19-3.	Example Intrinsic Names	19-4
Table 19-4.	Conjugation Instructions	19-5
Table 19-5.	Useful or Interesting FP16 Numbers.....	19-11
Table 19-6.	Conjugation Instructions	19-13
Table 19-7.	Conjugation Instructions	19-18
Table 20-1.	Related Links.....	20-1
Table 20-2.	Intel® AMX Instruction Throughput and Latency	20-3
Table 20-3.	Five loops in the Example 20-4 Code Listing.....	20-25
Table 20-4.	Accessed Data Sizes	20-25
Table 20-5.	Accessed Data Sizes	20-26
Table 20-6.	20-26
Table 20-7.	Simple partition of work between three threads.....	20-56
Table 20-8.	Optimized partition of work between three threads	20-56
Table 23-1.	Integer Pipeline Characteristics of the Knights Landing Microarchitecture.....	23-4
Table 23-2.	Vector Pipeline Characteristics of the Knights Landing Microarchitecture	23-5
Table 23-3.	Characteristics of Caching Resources	23-6
Table 23-4.	Alternatives to MSROM Instructions	23-10
Table 23-5.	Cycle Cost Building Blocks for Vectorization Estimate for Knights Landing Microarchitecture... ..	23-14
Table A-1.	Recommended Processor Optimization Options.....	A-2
Table B-1.	Performance Monitoring Taxonomy	B-9
Table B-2.	Cycle Accounting and Micro-ops Flow Recipe.....	B-16
Table B-3.	CMask/Inv/Edge/Thread Granularity of Events for Micro-op Flow	B-17
Table B-4.	Cycle Accounting of Wasted Work Due to Misprediction	B-18
Table B-5.	Cycle Accounting of Instruction Starvation.....	B-19
Table B-6.	CMask/Inv/Edge/Thread Granularity of Events for Micro-op Flow	B-20
Table B-7.	Approximate Latency of L2 Misses of Intel Xeon Processor 5500.....	B-22
Table B-8.	Load Latency Event Programming	B-25
Table B-9.	Data Source Encoding for Load Latency PEBS Record.....	B-25
Table B-10.	Core PMU Events to Drill Down L2 Misses	B-29
Table B-11.	Core PMU Events for Super Queue Operation.....	B-30
Table B-12.	Core PMU Event to Drill Down OFFCore Responses	B-30
Table B-13.	OFFCORE_RSP_0 MSR Programming.....	B-30
Table B-14.	Common Request and Response Types for OFFCORE_RSP_0 MSR.....	B-31
Table B-15.	Uncore PMU Events for Occupancy Cycles.....	B-36

Table B-16.	Common QHL Opcode Matching Facility Programming	B-38
Table C-1.	Core TLB Structure Size and Organization Across Multiple Intel Product Generations	C-2
Table C-2.	Calculating ITLB Miss Stall for Ghost.js	C-3
Table C-3.	ITLB MPKI and Executable Sizes Across Various Workloads	C-5
Table C-4.	Key Metrics for Ghost.js With and Without Large Pages	C-11
Table C-5.	Key Metrics for Web Tooling across Clear Linux and Ubuntu 18.04	C-12
Table C-6.	Key Metrics for Mediawiki Workload on HHVM	C-12
Table C-7.	Precise Front-end Events for ITLB Misses	C-13
Table C-8.	System Details	C-16
Table C-9.	Processor Information	C-16
Table C-10.	Kernel Vulnerability Status	C-17
Table D-1.	CPUID Signature Values of Of Recent Intel Microarchitectures	D-3
Table D-2.	Instruction Extensions Introduction by Microarchitectures (CPUID Signature)	D-4
Table D-3.	BMI1, BMI2 and General Purpose Instructions	D-4
Table D-4.	256-bit AVX2 Instructions	D-5
Table D-5.	Gather Timing Data from L1D*	D-6
Table D-6.	BMI1, BMI2 and General Purpose Instructions	D-7
Table D-7.	F16C,RDRAND Instructions	D-7
Table D-8.	256-bit AVX Instructions	D-7
Table D-9.	AESNI and PCLMULQDQ Instructions	D-9
Table D-10.	SSE4.2 Instructions	D-10
Table D-11.	SSE4.1 Instructions	D-10
Table D-12.	Supplemental Streaming SIMD Extension 3 Instructions	D-11
Table D-13.	Streaming SIMD Extension 3 SIMD Floating-point Instructions	D-12
Table D-14.	Streaming SIMD Extension 2 128-bit Integer Instructions	D-12
Table D-15.	Streaming SIMD Extension 2 Double-precision Floating-point Instructions	D-14
Table D-16.	Streaming SIMD Extension Single-precision Floating-point Instructions	D-15
Table D-17.	General Purpose Instructions	D-17
Table D-18.	Pointer-Chasing Variability of Software Measurable Latency of L1 Data Cache Latency	D-20
Table E-1.	Dispatch Port and Execution Stacks of the Haswell Microarchitecture	E-3
Table E-2.	Haswell Microarchitecture Execution Units and Representative Instructions	E-4
Table E-3.	Bypass Delay Between Producer and Consumer Micro-ops (cycles)	E-5
Table E-4.	Cache Parameters of the Haswell Microarchitecture	E-5
Table E-5.	TLB Parameters of the Haswell Microarchitecture	E-6
Table E-6.	Components of the Front End	E-6
Table E-7.	TLB Parameters of the Broadwell Microarchitecture	E-8
Table E-8.	Components of the Front End of Sandy Bridge Microarchitecture	E-10
Table E-9.	ICache and ITLB of Sandy Bridge Microarchitecture	E-11
Table E-10.	Dispatch Port and Execution Stacks	E-16
Table E-11.	Execution Core Writeback Latency (cycles)	E-17
Table E-12.	Cache Parameters	E-18
Table E-13.	Lookup Order and Load Latency	E-18
Table E-14.	L1 Data Cache Components	E-19
Table E-15.	Effect of Addressing Modes on Load Latency	E-20
Table E-16.	DTLB and STLB Parameters	E-21
Table E-17.	Store Forwarding Conditions (1 and 2 byte stores)	E-21
Table E-18.	Store Forwarding Conditions (4-16 byte stores)	E-22
Table E-19.	32-byte Store Forwarding Conditions (0-15 byte alignment)	E-22
Table E-20.	32-byte Store Forwarding Conditions (16-31 byte alignment)	E-22
Table E-21.	Components of the Front End	E-28
Table E-22.	Issue Ports of Intel Core Microarchitecture and Enhanced Intel Core Microarchitecture	E-33
Table E-23.	Cache Parameters of Processors based on Intel Core Microarchitecture	E-38
Table E-24.	Characteristics of Load and Store Operations in Intel Core Microarchitecture	E-39
Table E-25.	Bypass Delay Between Producer and Consumer Micro-ops (cycles)	E-44
Table E-26.	Issue Ports of Nehalem Microarchitecture	E-44
Table E-27.	Cache Parameters of Intel Core i7 Processors	E-45
Table E-28.	Performance Impact of Address Alignments of MOVDQU from L1	E-46
Table F-1.	Instruction Latency/Throughput Summary of Intel Atom® Microarchitecture	F-7
Table F-2.	Intel Atom® Microarchitecture Instructions Latency Data	F-14

Table F-3.	Function Unit Mapping of the Silvermont Microarchitecture	F-21
Table F-5.	Comparison of Distributed Reservation Stations on Scheduling Uops	F-25
Table F-6.	Function Unit Mapping of the Goldmont Microarchitecture	F-25
Table F-4.	Comparison of Front End Cluster Features	F-25
Table F-7.	Comparison of MEC Resources	F-26
Table F-8.	Comparison of Front End Cluster Features	F-27
Table F-9.	Comparison of Distributed Reservation Stations on Scheduling Uops	F-28
Table F-10.	Function Unit Mapping of the Goldmont Plus Microarchitecture	F-28
Table F-11.	Alternatives to MSROM Instructions	F-29
Table F-12.	Comparison of Decoder Capabilities	F-31
Table F-13.	Integer Multiply Operation Latency	F-34
Table F-14.	Floating-Point and SIMD Integer Latency	F-37
Table F-15.	Unsigned Integer Division Operation Latency	F-38
Table F-16.	Signed Integer Division Operation Latency	F-39
Table F-17.	Store Forwarding Conditions (1 and 2 Byte Stores)	F-40
Table F-18.	Store Forwarding Conditions (4-16 Byte Stores)	F-40
Table F-19.	Instructions Latency and Throughput Recent Microarchitectures for Intel Atom® Processors ...	F-42

- User/Source Coding Rule 1. (M impact, L generality)** If an indirect branch has two or more common taken targets and at least one of those targets is correlated with branch history leading up to the branch, then convert the indirect branch to a tree where one or more indirect branches are preceded by conditional branches to those targets. Apply this “peeling” procedure to the common target of an indirect branch that correlates to branch history3-9
- User/Source Coding Rule 2. (H impact, M generality)** Use the smallest possible floating-point or SIMD data type, to enable more parallelism with the use of a (longer) SIMD vector. For example, use single precision instead of double precision where possible 3-35
- User/Source Coding Rule 3. (M impact, ML generality)** Arrange the nesting of loops so that the innermost nesting level is free of inter-iteration dependencies. Especially avoid the case where the store of data in an earlier iteration happens lexically after the load of that data in a future iteration, something which is called a lexically backward dependence 3-35
- User/Source Coding Rule 4. (M impact, ML generality)** Avoid the use of conditional branches inside loops and consider using SSE instructions to eliminate branches 3-35
- User/Source Coding Rule 5. (M impact, ML generality)** Keep induction (loop) variable expressions simple 3-35
- User/Source Coding Rule 6. (H impact, M generality)** Pad data structures defined in the source code so that every data element is aligned to a natural operand size address boundary 3-51
- User/Source Coding Rule 7. (M impact, L generality)** Beware of false sharing within a cache line (64 bytes) 3-53
- User/Source Coding Rule 8. (H impact, ML generality)** Consider using a special memory allocation library with address offset capability to avoid aliasing. 3-54
- User/Source Coding Rule 9. (M impact, M generality)** When padding variable declarations to avoid aliasing, the greatest benefit comes from avoiding aliasing on second-level cache lines, suggesting an offset of 128 bytes or more 3-54
- User/Source Coding Rule 10. (H impact, H generality)** Optimization techniques such as blocking, loop interchange, loop skewing, and packing are best done by the compiler. Optimize data structures either to fit in one-half of the first-level cache or in the second-level cache; turn on loop optimizations in the compiler to enhance locality for nested loops 3-57
- User/Source Coding Rule 11. (M impact, ML generality)** If there is a blend of reads and writes on the bus, changing the code to separate these bus transactions into read phases and write phases can help performance 3-58
- User/Source Coding Rule 12. (H impact, H generality)** To achieve effective amortization of bus latency, software should favor data access patterns that result in higher concentrations of cache miss patterns, with cache miss strides that are significantly smaller than half the hardware prefetch trigger threshold 3-58
- User/Source Coding Rule 13. (M impact, M generality)** Enable the compiler’s use of SSE, SSE2, AVX, AVX2, and possibly more advanced SIMD instruction sets (AVX-512) with appropriate switches. Favor scalar SIMD code generation to replace x87 code generation 3-67
- User/Source Coding Rule 14. (H impact, ML generality)** Make sure your application stays in range to avoid denormal values, underflows 3-67
- User/Source Coding Rule 15. (M impact, ML generality)** Usually, math libraries take advantage of the transcendental instructions (for example, FSIN) when evaluating elementary functions. If there is no critical need to evaluate the transcendental functions using the extended precision of 80 bits, applications should consider an alternate, software-based approach, such as a look-up-table-based algorithm using interpolation techniques. It is possible to improve transcendental performance with

these techniques by choosing the desired numeric precision and the size of the look-up table, and by taking advantage of the parallelism of the SSE and the SSE2 instructions. 3-68

User/Source Coding Rule 16. (H impact, ML generality) Denormalized floating-point constants should be avoided as much as possible 3-68

User/Source Coding Rule 17. If CLFLUSHOPT is available, use CLFLUSHOPT over CLFLUSH and use SFENCE to guard CLFLUSHOPT to ensure write order is globally observed. If CLUSHOPT is not available, consider flushing large buffers with CLFLUSH in smaller chunks of less than 4KB. 8-11

User/Source Coding Rule 18. (M impact, H generality) Insert the PAUSE instruction in fast spin loops and keep the number of loop repetitions to a minimum to improve overall system performance. 10-12

User/Source Coding Rule 19. (M impact, L generality) Replace a spin lock that may be acquired by multiple threads with pipelined locks such that no more than two threads have write accesses to one lock. If only one thread needs to write to a variable shared by two threads, there is no need to use a lock. 10-13

User/Source Coding Rule 20. (H impact, M generality) Use a thread-blocking API in a long idle loop to free up the processor 10-13

User/Source Coding Rule 21. (H impact, M generality) Beware of false sharing within a cache line or within a sector. Allocate critical data or locks separately using alignment granularity not smaller than the “false-sharing threshold” 10-15

User/Source Coding Rule 22. (M impact, ML generality) Place each synchronization variable alone, separated by 128 bytes or in a separate cache line. 10-16

User/Source Coding Rule 23. (H impact, L generality) Do not place any spin lock variable to span a cache line boundary 10-16

User/Source Coding Rule 24. (M impact, H generality) Improve data and code locality to conserve bus command bandwidth. 10-17

User/Source Coding Rule 25. (M impact, L generality) Avoid excessive use of software prefetch instructions and allow automatic hardware prefetcher to work. Excessive use of software prefetches can significantly and unnecessarily increase bus utilization if used inappropriately. 10-18

User/Source Coding Rule 26. (M impact, M generality) Consider using overlapping multiple back-to-back memory reads to improve effective cache miss latencies. 10-18

User/Source Coding Rule 27. (M impact, M generality) Consider adjusting the sequencing of memory references such that the distribution of distances of successive cache misses of the last level cache peaks towards 64 bytes. 10-18

User/Source Coding Rule 28. (M impact, M generality) Use full write transactions to achieve higher data throughput. 10-18

User/Source Coding Rule 29. (H impact, H generality) Use cache blocking to improve locality of data access. Target one quarter to one half of the cache size when targeting Intel processors supporting HT Technology or target a block size that allow all the logical processors serviced by a cache to share that cache simultaneously. 10-19

User/Source Coding Rule 30. (H impact, M generality) Minimize the sharing of data between threads that execute on different bus agents sharing a common bus. The situation of a platform consisting of multiple bus domains should also minimize data sharing across bus domains 10-20

User/Source Coding Rule 31. (H impact, H generality) Minimize data access patterns that are offset by multiples of 64 KBytes in each thread. 10-21

User/Source Coding Rule 32. (M impact, L generality) Avoid excessive loop unrolling to ensure the LSD is operating efficiently 10-22

User/Source Coding Rule 33. Factor in precision and rounding characteristics of FMA instructions when replacing multiply/add operations executing non-FMA instructions. 14-48

User/Source Coding Rule 34. Factor in result-dependency, latency of FP add vs. FMA instructions when replacing FP add operations with FMA instructions 14-48

User/Source Coding Rule 35. Consider using unrolling technique for loops containing back-to-back dependent FMA, FP Add or Vector MUL operations, The unrolling factor can be chosen by considering

the latency of the critical instruction of the dependency chain and the number of pipes available to execute that instruction 14-50

User/Source Coding Rule 36. When using RTM for implementing lock elision, always test for lock inside the transactional region. 15-11

User/Source Coding Rule 37. RTM abort handlers must provide a valid tested non transactional fallback path. 15-13

- Assembler/Compiler Coding Rule 1. (MH impact, M generality)** Arrange code to make basic blocks contiguous and eliminate unnecessary branches.....3-5
- Assembler/Compiler Coding Rule 2. (M impact, ML generality)** Use the SETCC and CMOV instructions to eliminate unpredictable conditional branches where possible. Do not do this for predictable branches. Do not use these instructions to eliminate all unpredictable conditional branches (because using these instructions will incur execution overhead due to the requirement for executing both paths of a conditional branch). In addition, converting a conditional branch to SETCC or CMOV trades off control flow dependence for data dependence and restricts the capability of the out-of-order engine. When tuning, note that all Intel 64 and IA-32 processors usually have very high branch prediction rates. Consistently mispredicted branches are generally rare. Use these instructions only if the increase in computation time is less than the expected cost of a mispredicted branch.3-5
- Assembler/Compiler Coding Rule 3. (M impact, H generality)** Arrange code to be consistent with the static branch prediction algorithm: make the fall-through code following a conditional branch be the likely target for a branch with a forward target, and make the fall-through code following a conditional branch be the unlikely target for a branch with a backward target.3-6
- Assembler/Compiler Coding Rule 4. (MH impact, MH generality)** Near calls must be matched with near returns, and far calls must be matched with far returns. Pushing the return address on the stack and jumping to the routine to be called is not recommended since it creates a mismatch in calls and returns.3-7
- Assembler/Compiler Coding Rule 5. (MH impact, MH generality)** Selectively inline a function if doing so decreases code size or if the function is small and the call site is frequently executed.3-8
- Assembler/Compiler Coding Rule 6. (ML impact, ML generality)** If there are more than 16 nested calls and returns in rapid succession; consider transforming the program with inline to reduce the call depth.3-8
- Assembler/Compiler Coding Rule 7. (ML impact, ML generality)** Favor inlining small functions that contain branches with poor prediction rates. If a branch misprediction results in a RETURN being prematurely predicted as taken, a performance penalty may be incurred.3-8
- Assembler/Compiler Coding Rule 8. (L impact, L generality)** If the last statement in a function is a call to another function, consider converting the call to a jump. This will save the call/return overhead as well as an entry in the return stack buffer.3-8
- Assembler/Compiler Coding Rule 9. (M impact, L generality)** Do not put more than four branches in a 16-byte chunk.3-8
- Assembler/Compiler Coding Rule 10. (M impact, L generality)** Do not put more than two end loop branches in a 16-byte chunk.3-8
- Assembler/Compiler Coding Rule 11. (M impact, H generality)** When executing code from the Decoded Icache, direct branches that are mostly taken should have all their instruction bytes in a 64B cache line and nearer the end of that cache line. Their targets should be at or near the beginning of a 64B cache line.3-8
- Assembler/Compiler Coding Rule 12. (M impact, H generality)** If the body of a conditional is not likely to be executed, it should be placed in another part of the program. If it is highly unlikely to be executed and code locality is an issue, it should be placed on a different code page.3-8
- Assembler/Compiler Coding Rule 13. (M impact, L generality)** When indirect branches are present, try to put the most likely target of an indirect branch immediately following the indirect branch. Alternatively, if indirect branches are common but they cannot be predicted by branch prediction hardware, then follow the indirect branch with a UD2 instruction, which will stop the processor from decoding down the fall-through path.3-8
- Assembler/Compiler Coding Rule 14. (H impact, M generality)** Unroll small loops until the overhead of the branch and induction variable accounts (generally) for less than 10% of the execution time of the loop.3-11
- Assembler/Compiler Coding Rule 15. (M impact, M generality)** Unroll loops that are frequently executed and have a predictable number of iterations to reduce the number of iterations to 16 or fewer. Do this unless it increases code size so that the working set no longer fits in the instruction

- cache. If the loop body contains more than one conditional branch, then unroll so that the number of iterations is 16/(# conditional branches). 3-11
- Assembler/Compiler Coding Rule 16. (ML impact, M generality)** For improving fetch/decode throughput, Give preference to memory flavor of an instruction over the register-only flavor of the same instruction, if such instruction can benefit from micro-fusion..... 3-11
- Assembler/Compiler Coding Rule 17. (M impact, ML generality)** Employ macrofusion where possible using instruction pairs that support macrofusion. Prefer TEST over CMP if possible. Use unsigned variables and unsigned jumps when possible. Try to logically verify that a variable is non-negative at the time of comparison. Avoid CMP or TEST of MEM-IMM flavor when possible. However, do not add other instructions to avoid using the MEM-IMM flavor. 3-14
- Assembler/Compiler Coding Rule 18. (M impact, ML generality)** Software can enable macro fusion when it can be logically determined that a variable is non-negative at the time of comparison; use TEST appropriately to enable macrofusion when comparing a variable with 0. 3-15
- Assembler/Compiler Coding Rule 19. (MH impact, MH generality)** Favor generating code using imm8 or imm32 values instead of imm16 values. 3-16
- Assembler/Compiler Coding Rule 20. (M impact, ML generality)** Ensure instructions using 0xF7 opcode byte does not start at offset 14 of a fetch line; and avoid using these instruction to operate on 16-bit data, upcast short data to 32 bits. 3-17
- Assembler/Compiler Coding Rule 21. (MH impact, MH generality)** Break up a loop body with a long sequence of instructions into loops of shorter instruction blocks of no more than the size of the LSD..... 3-18
- Assembler/Compiler Coding Rule 22. (M impact, M generality)** Avoid putting explicit references to ESP in a sequence of stack operations (POP, PUSH, CALL, RET). 3-19
- Assembler/Compiler Coding Rule 23. (ML impact, L generality)** Use simple instructions that are less than eight bytes in length. 3-19
- Assembler/Compiler Coding Rule 24. (M impact, MH generality)** Avoid using prefixes to change the size of immediate and displacement. 3-19
- Assembler/Compiler Coding Rule 25. (M impact, H generality)** Favor single-micro-operation instructions. Also favor instruction with shorter latencies. 3-20
- Assembler/Compiler Coding Rule 26. (M impact, L generality)** Avoid prefixes, especially multiple non-0F-prefixed opcodes..... 3-20
- Assembler/Compiler Coding Rule 27. (M impact, L generality)** Do not use many segment registers. 3-20
- Assembler/Compiler Coding Rule 28. (M impact, M generality)** Avoid using complex instructions (for example, enter, leave, or loop) that have more than four μ ops and require multiple cycles to decode. Use sequences of simple instructions instead. 3-20
- Assembler/Compiler Coding Rule 29. (MH impact, M generality)** Use push/pop to manage stack space and address adjustments between function calls/returns instead of enter/leave. Using enter instruction with non-zero immediates can experience significant delays in the pipeline in addition to misprediction..... 3-20
- Assembler/Compiler Coding Rule 30. (ML impact, L generality)** If an LEA instruction using the scaled index is on the critical path, a sequence with ADDs may be better..... 3-22
- Assembler/Compiler Coding Rule 31. (ML impact, L generality)** Avoid ROTATE by register or ROTATE by immediate instructions. If possible, replace with a ROTATE by 1 instruction. 3-24
- Assembler/Compiler Coding Rule 32. (M impact, ML generality)** Use dependency-breaking-idiom instructions to set a register to 0, or to break a false dependence chain resulting from re-use of registers. In contexts where the condition codes must be preserved, move 0 into the register instead. This requires more code space than using XOR and SUB, but avoids setting the condition codes.3-25
- Assembler/Compiler Coding Rule 33. (M impact, MH generality)** Break dependences on portions of registers between instructions by operating on 32-bit registers instead of partial registers. For moves, this can be accomplished with 32-bit moves or by using MOVZX. 3-26
- Assembler/Compiler Coding Rule 34. (M impact, M generality)** Try to use zero extension or operate on 32-bit operands instead of using moves with sign extension..... 3-26

- Assembler/Compiler Coding Rule 35. (ML impact, L generality)** Avoid placing instructions that use 32-bit immediates which cannot be encoded as sign-extended 16-bit immediates near each other. Try to schedule μ ops that have no immediate immediately before or after μ ops with 32-bit immediates. 3-26
- Assembler/Compiler Coding Rule 36. (ML impact, M generality)** Use the TEST instruction instead of AND when the result of the logical AND is not used. This saves μ ops in execution. Use a TEST of a register with itself instead of a CMP of the register to zero, this saves the need to encode the zero and saves encoding space. Avoid comparing a constant to a memory operand. It is preferable to load the memory operand and compare the constant to a register. 3-27
- Assembler/Compiler Coding Rule 37. (ML impact, M generality)** Eliminate unnecessary compare with zero instructions by using the appropriate conditional jump instruction when the flags are already set by a preceding arithmetic instruction. If necessary, use a TEST instruction instead of a compare. Be certain that any code transformations made do not introduce problems with overflow. 3-27
- Assembler/Compiler Coding Rule 38. (H impact, MH generality)** For small loops, placing loop invariants in memory is better than spilling loop-carried dependencies. 3-28
- Assembler/Compiler Coding Rule 39. (M impact, ML generality)** Avoid introducing dependences with partial floating-point register writes, e.g. from the MOVSD XMMREG1, XMMREG2 instruction. Use the MOVAPD XMMREG1, XMMREG2 instruction instead. 3-35
- Assembler/Compiler Coding Rule 40. (H impact, M generality)** Pass parameters in registers instead of on the stack where possible. Passing arguments on the stack requires a store followed by a reload. While this sequence is optimized in hardware by providing the value to the load directly from the memory order buffer without the need to access the data cache if permitted by store-forwarding restrictions, floating-point values incur a significant latency in forwarding. Passing floating-point arguments in (preferably XMM) registers should save this long latency operation. 3-46
- Assembler/Compiler Coding Rule 41. (H impact, M generality)** A load that forwards from a store must have the same address start point and therefore the same alignment as the store data. 3-48
- Assembler/Compiler Coding Rule 42. (H impact, M generality)** The data of a load which is forwarded from a store must be completely contained within the store data. 3-48
- Assembler/Compiler Coding Rule 43. (H impact, ML generality)** If it is necessary to extract a non-aligned portion of stored data, read out the smallest aligned portion that completely contains the data and shift/mask the data as necessary. This is better than incurring the penalties of a failed store-forward. 3-48
- Assembler/Compiler Coding Rule 44. (MH impact, ML generality)** Avoid several small loads after large stores to the same area of memory by using a single large read and register copies as needed. 3-48
- Assembler/Compiler Coding Rule 45. (H impact, MH generality)** Where it is possible to do so without incurring other penalties, prioritize the allocation of variables to registers, as in register allocation and for parameter passing, to minimize the likelihood and impact of store-forwarding problems. Try not to store-forward data generated from a long latency instruction - for example, MUL or DIV. Avoid store-forwarding data for variables with the shortest store-load distance. Avoid store-forwarding data for variables with many and/or long dependence chains, and especially avoid including a store forward on a loop-carried dependence chain. 3-51
- Assembler/Compiler Coding Rule 46. (M impact, MH generality)** Calculate store addresses as early as possible to avoid having stores block loads. 3-51
- Assembler/Compiler Coding Rule 47. (H impact, M generality)** Try to arrange data structures such that they permit sequential access. 3-53
- Assembler/Compiler Coding Rule 48. (H impact, M generality)** Make sure that the stack is aligned at the largest multi-byte granular data type boundary matching the register width. 3-53
- Assembler/Compiler Coding Rule 49. (H impact, M generality)** Avoid having a store followed by a non-dependent load with addresses that differ by a multiple of 4 KBytes. Also, lay out data or order computation to avoid having cache lines that have linear addresses that are a multiple of 64 KBytes apart in the same working set. Avoid having more than 4 cache lines that are some multiple of 2

KBytes apart in the same first-level cache working set, and avoid having more than 8 cache lines that are some multiple of 4 KBytes apart in the same first-level cache working set.	3-54
Assembler/Compiler Coding Rule 50. (M impact, L generality) If (hopefully read-only) data must occur on the same page as code, avoid placing it immediately after an indirect jump. For example, follow an indirect jump with its mostly likely target, and place the data after an unconditional branch.	3-55
Assembler/Compiler Coding Rule 51. (H impact, L generality) Always put code and data on separate pages. Avoid self-modifying code wherever possible. If code is to be modified, try to do it all at once and make sure the code that performs the modifications and the code being modified are on separate 4-KByte pages or on separate aligned 1-KByte subpages.	3-55
Assembler/Compiler Coding Rule 52. (H impact, L generality) If an inner loop writes to more than four arrays (four distinct cache lines), apply loop fission to break up the body of the loop such that only four arrays are being written to in each iteration of each of the resulting loops.	3-56
Assembler/Compiler Coding Rule 53. (H impact, M generality) Minimize changes to bits 8-12 of the floating-point control word. Changes for more than two values (each value being a combination of the following bits: precision, rounding and infinity control, and the rest of bits in FCW) leads to delays that are on the order of the pipeline depth.....	3-70
Assembler/Compiler Coding Rule 54. (H impact, L generality) Minimize the number of changes to the rounding mode. Do not use changes in the rounding mode to implement the floor and ceiling functions if this involves a total of more than two values of the set of rounding, precision, and infinity bits.	3-71
Assembler/Compiler Coding Rule 55. (H impact, L generality) Minimize the number of changes to the precision mode.....	3-72
Assembler/Compiler Coding Rule 56. (M impact, M generality) Use Streaming SIMD Extensions 2 or Streaming SIMD Extensions unless you need an x87 feature. Most SSE2 arithmetic operations have shorter latency than their X87 counterpart and they eliminate the overhead associated with the management of the X87 register stack.....	3-72
Assembler/Compiler Coding Rule 57. (H impact, M generality) Use the 32-bit versions of instructions in 64-bit mode to reduce code size unless the 64-bit version is necessary to access 64-bit data or additional registers.	12-1
Assembler/Compiler Coding Rule 58. (M impact, MH generality) When they are needed to reduce register pressure, use the 8 extra general purpose registers for integer code and 8 extra XMM registers for floating-point or SIMD code.	12-2
Assembler/Compiler Coding Rule 59. (ML impact, M generality) Prefer 64-bit by 64-bit integer multiplication that produces 64-bit results over multiplication that produces 128-bit results.	12-2
Assembler/Compiler Coding Rule 60. (ML impact, M generality) Stagger accessing the high 64-bit result of a 128-bit multiplication after accessing the low 64-bit results.	12-2
Assembler/Compiler Coding Rule 61. (ML impact, M generality) Use the 64-bit versions of multiply for 32-bit integer multiplies that require a 64 bit result.	12-6
Assembler/Compiler Coding Rule 62. (ML impact, M generality) Use the 64-bit versions of add for 64-bit adds.....	12-6
Assembler/Compiler Coding Rule 63. (L impact, L generality) If software prefetch instructions are necessary, use the prefetch instructions provided by SSE.	12-6
Assembler/Compiler Coding Rule 64. (H impact, H generality) Whenever a 256-bit AVX code block and 128-bit SSE code block might execute in sequence, use the VZERoupper instruction to facilitate a transition to a "Clean" state for the next block to execute from.	14-10
Assembler/Compiler Coding Rule 65. (H impact, H generality) Add VZERoupper instruction after 256-bit AVX instructions are executed and before any function call that might execute SSE code. Add VZERoupper at the end of any function that uses 256-bit AVX instructions.	14-10
Assembler/Compiler Coding Rule 66. (H impact, M generality) Align data to 32-byte boundary when possible. Prefer store alignment over load alignment.	14-20
Assembler/Compiler Coding Rule 67. (M impact, H generality) Align data to 32-byte boundary when possible. If it is not possible to align both loads and stores, then prefer store alignment over load alignment.....	14-22

Assembler/Compiler Coding Rule 68. (M impact, M generality) Use Blend instructions in lieu of shuffle instruction in AVX whenever possible..... 14-32

- Tuning Suggestion 1.** In rare cases, a performance problem may be caused by executing data on a code page as instructions. This is very likely to happen when execution is following an indirect branch that is not resident in the trace cache. If this is clearly causing a performance problem, try moving the data elsewhere, or inserting an illegal opcode or a `pause` instruction immediately after the indirect branch. Note that the latter two alternatives may degrade performance in some circumstances. 3-55
- Tuning Suggestion 2.** Optimize single threaded code to maximize execution throughput first. 10-25
- Tuning Suggestion 3.** Employ efficient threading model, leverage available tools (such as Intel Threading Building Block, Intel Thread Checker, Intel Thread Profiler) to achieve optimal processor scaling with respect to the number of physical processors or processor cores. 10-25
- Tuning Suggestion 4.** Use a profiling tool to identify the transactional aborts that contribute most to any performance loss. 15-4
- Tuning Suggestion 5.** Add padding to put the two conflicting variables in separate cache line. 15-5
- Tuning Suggestion 6.** Reorganize the data structure to minimize false sharing whenever possible. 15-5
- Tuning Suggestion 7.** Global statistics may also be sampled rather than being updated for every operation. 15-5
- Tuning Suggestion 8.** Avoid unnecessary statistics in critical sections. 15-5
- Tuning Suggestion 9.** Consider maintaining statistics in critical sections on a per-thread basis. 15-5
- Tuning Suggestion 10.** Transactional regions during program startup may observe a higher abort rate than during steady state. 15-9
- Tuning Suggestion 11.** Operating system services may cause infrequent transactional aborts due to background activity. 15-9
- Tuning Suggestion 12.** Keep any transactional only code paths simple and inlined. 15-9
- Tuning Suggestion 13.** Minimize code paths that are only executed transactionally. 15-9
- Tuning Suggestion 14.** Don't use an RTM wrapper if the lock variable is not readable in the wrapper. 15-11
- Tuning Suggestion 15.** When RTM is used for lock elision, forward progress is easily ensured by acquiring the lock. 15-12
- Tuning Suggestion 16.** Lock Busy retries should wait for the lock to become free again. 15-13
- Tuning Suggestion 17.** For Read/Write locks elide the complete lock operation, not the building block locks. 15-15
- Tuning Suggestion 18.** Use RTM to elide ticket locks. 15-15
- Tuning Suggestion 19.** Use an RTM wrapper for locks that implement queuing as part of the initial atomic operation. 15-16
- Tuning Suggestion 20.** For meta-locking elide the full outer lock, not the building block locks. 15-17
- Tuning Suggestion 21.** Always include a `pause` instruction in the wait loop of a HLE spinlock. 15-19
- Tuning Suggestion 22.** The aborts with the highest cost should be examined first. 15-22
- Tuning Suggestion 23.** The TX Abort Information has additional information about the transactional abort. 15-22
- Tuning Suggestion 24.** Instruction aborts should be analyzed early, but only when they are costly and happen after program startup. 15-22
- Tuning Suggestion 25.** For data conflicts or capacity aborts, concentrate on the whole critical section, not just the instruction address reported at the time of the abort. 15-22
- Tuning Suggestion 26.** The profiler should support displaying the ReturnIP with callgraph for non-Instruction abort events, but display the EventingRIP for instruction abort events. 15-22
- Tuning Suggestion 27.** The PEBS TX Abort Information bits should be all displayed by the profiling tool. 15-22
- Tuning Suggestion 28.** The profiling tool should display the abort code to the user for RTM aborts. 15-23
- Tuning Suggestion 29.** The profiler should have options to display ReturnIP and EventingIP. 15-23

- Tuning Suggestion 30.** The stack callgraph is always associated with the ReturnIP and may appear noncontiguous with the EventingIP. 15-23
- Tuning Suggestion 31.** To see function calls inside the transactional region use LBRs or SDE. 15-23
- Tuning Suggestion 32.** The PEBS profiling handler should support sampling LBRs on abort and report them to the user. 15-23
- Tuning Suggestion 33.** Intel TSX is designed for critical sections and thus the latency profiles of the XBEGIN/XEND instructions and XACQUIRE/XRELEASE prefixes are intended to match the LOCK prefixed instructions. These instructions should not be expected to have the latency of a regular load operation. 15-25

(MH impact, ML generality) For Intel Atom processors, minimize the presence of complex instructions requiring MSROM to take advantage the optimal decode bandwidth provided by the two decode units. 4

(M impact, H generality) For Intel Atom processors, keeping the instruction working set footprint small will help the front end to take advantage the optimal decode bandwidth provided by the two decode units. 4

(MH impact, ML generality) For Intel Atom processors, avoiding back-to-back X87 instructions will help the front end to take advantage the optimal decode bandwidth provided by the two decode units. 4

(M impact, H generality) For Intel Atom processors, place a MOV instruction between a flag producer instruction and a flag consumer instruction that would have incurred a two-cycle delay. This will prevent partial flag dependency. 5

(MH impact, H generality) For Intel Atom processors, LEA should be used for address manipulation; but software should avoid the following situations which creates dependencies from ALU to AGU: an ALU instruction (instead of LEA) for address manipulation or ESP updates; a LEA for ternary addition or non-destructive writes which do not feed address generation. Alternatively, hoist producer instruction more than 3 cycles above the consumer instruction that uses the AGU. 6

(M impact, M generality) For Intel Atom processors, sequence an independent FP or integer multiply after an integer multiply instruction to take advantage of pipelined IMUL execution. 7

(M impact, M generality) For Intel Atom processors, hoist the producer instruction for the implicit register count of an integer shift instruction before the shift instruction by at least two cycles. 7

(M impact, MH generality) For Intel Atom processors, LEA, simple loads and POP are slower if the input is smaller than 4 bytes. 7

(MH impact, H generality) For Intel Atom processors, prefer SIMD instructions operating on XMM register over X87 instructions using FP stack. Use Packed single-precision instructions where possible. Replace packed double-precision instruction with scalar double-precision instructions. 8

(M impact, ML generality) For Intel Atom processors, library software performing sophisticated math operations like transcendental functions should use SIMD instructions operating on XMM register instead of native X87 instructions. 8

(M impact, M generality) For Intel Atom processors, enable DAZ and FTZ whenever possible. 8

(H impact, L generality) For Intel Atom processors, use divide instruction only when it is absolutely necessary, and pay attention to use the smallest data size operand. 9

(MH impact, M generality) For Intel Atom processors, prefer a sequence MOVAPS+PALIGN over MOVUPS. Similarly, MOVDQA+PALIGNR is preferred over MOVDQU. 9

(MH impact, H generality) For Intel Atom processors, ensure data are aligned in memory to its natural size. For example, 4-byte data should be aligned to 4-byte boundary, etc. Additionally, smaller access (less than 4 bytes) within a chunk may experience delay if they touch different bytes. 10

(H impact, ML generality) For Intel Atom processors, use segments with base set to 0 whenever possible; avoid non-zero segment base address that is not aligned to cache line boundary at all cost. 10

(H impact, L generality) For Intel Atom processors, when using non-zero segment bases, Use DS, FS, GS; string operation should use implicit ES. 10

(M impact, ML generality) For Intel Atom processors, favor using ES, DS, SS over FS, GS with

zero segment base. 10

(MH impact, M generality) For Intel Atom processors, “bool” and “char” value should be passed onto and read off the stack as 32-bit data. 11

(MH impact, M generality) For Intel Atom processors, favor register form of PUSH/POP and avoid using LEAVE; Use LEA to adjust ESP instead of ADD/SUB. 11