



StrongARM** SA-110 Microprocessor

Brief Datasheet

Product Features

The StrongARM** SA-110 Microprocessor (SA-110), the first member of the StrongARM** family of high-performance, low-power microprocessors, is optimized for meeting embedded consumer application and portable application requirements. Offering power-saving features, low cost, and high performance and price/performance, the SA-110 is a solution for high-bandwidth network switching, intelligent office machines, storage systems, and internet appliances, as well as digital cameras, bar-code scanners, and other emerging consumer applications. In addition, to delivering performance requirements in a low-power design, the SA-110 offers compatibility with existing ARM** development tools and operating systems.

- High performance
 - 115 Dhrystone 2.1 MIPS @ 100 MHz
 - 185 Dhrystone 2.1 MIPS @ 160 MHz
 - 192 Dhrystone 2.1 MIPS @ 166 MHz
 - 230 Dhrystone 2.1 MIPS @ 200 MHz
 - 268 Dhrystone 2.1 MIPS @ 233 MHz
- Low power (normal mode)
 - 130 mW @ 1.65 V/100 MHz
 - 170 mW @ 1.65 V/160 MHz
 - 230 mW @ 2.0 V/166 MHz
 - 330 mW @ 2.0 V/200 MHz
 - 420 mW @ 2.0 V/233 MHz
- Internal phase-locked loop (PLL)
 - 3.68- or 3.56-MHz oscillator
- Power-management features
 - Idle (power-down) mode
 - Sleep (power-down) mode
- Big and little endian operating modes
- 144-pin thin quad flat pack (TQFP)
- 32-way set-associative caches
 - 16 Kbyte instruction cache
 - 16 Kbyte write-back data cache
- 32-entry MMUs
 - Maps 4 Kbyte, 64 Kbyte, or 1 Mbyte
- Write buffer
 - 8-entry, 16 bytes each
- Memory bus
 - Asynchronous or synchronous
 - 0-33 MHz @ 100 MHz
 - 0-53 MHz @ 160 MHz
 - 0-53 MHz @ 166 MHz
 - 0-66 MHz @ 200 MHz
 - 0-66 MHz @ 233 MHz
- 3.3-V I/O interface



Information in this document is provided in connection with Intel products. No license, express or implied, by estoppel or otherwise, to any intellectual property rights is granted by this document. Except as provided in Intel's Terms and Conditions of Sale for such products, Intel assumes no liability whatsoever, and Intel disclaims any express or implied warranty, relating to sale and/or use of Intel products including liability or warranties relating to fitness for a particular purpose, merchantability, or infringement of any patent, copyright or other intellectual property right. Intel products are not intended for use in medical, life saving, or life sustaining applications.

Intel may make changes to specifications and product descriptions at any time, without notice.

Contact your local Intel sales office or your distributor to obtain the latest specifications and before placing your product order.

Copies of documents which have an ordering number and are referenced in this document, or other Intel literature may be obtained by calling 1-800-548-4725 or by visiting Intel's website at <http://www.intel.com>.

Copyright © Intel Corporation, 1998

*Third-party brands and names are the property of their respective owners.

**ARM and StrongARM are trademarks of Advanced RISC Machines, Ltd.

Benefits

- Price/performance offers a solution for any consumer product that demands high performance within a tight cost budget.
- Complete suite of software and hardware tools speeds time to market.
- High performance allows DSP function (for example, V.34 bis Softmodem*) to be implemented in software, thus reducing system cost.
- Compatibility with ARM** and the availability of key third-party development tools (real-time operating systems) reduces design efforts and cost.
- Range of core logic companion chips available expands application possibilities.

Applications

- Embedded control applications
 - Internetworking: routers, bridges, LAN switches
 - Office automation: printers, scanners, copiers
 - Telecommunication: PBX, cellular base station
 - Storage peripherals: drive and RAID controllers
 - PC add-ins: intelligent I/O cards, LAN/WAN
- Network appliances
 - Internet terminals (PCs)
 - Network computers
 - Digital set-top devices
 - Internet television
 - Video kiosks
 - Web phone
 - Video phone
- Portable products
 - Digital cameras
 - Organizers
 - Bar-code scanners

Operating Systems

- Apple Computer, Inc.
- Microware
- Psion
- Sun Microsystems
- Wind River
- — Newton OS*
- — OS-9*
- — EPOC32*
- — JavaOS*
- — VxWorks*

Description

The SA-110 is a general-purpose, 32-bit RISC microprocessor with a 16 Kbyte instruction cache (Icache); a 16 Kbyte write-back data cache (Dcache); a write buffer; and a memory-management unit (MMU) combined in a single component. The five-stage pipeline distributes tasks evenly over time to remove bottlenecks, ensuring high throughput for the core logic. The SA-110 on-chip MMU supports a conventional two-level page-table structure, with a number of extensions. These features result in a high instruction throughput and real-time response for a small and cost-effective microprocessor.

Microarchitecture

The SA-110 is a high-performance implementation of Advanced RISC Machines, Ltd.'s ARM^{**} Version 4 architecture specification. Figure 1 shows a block diagram of the SA-110.

Figure 1. Block Diagram of the SA-110

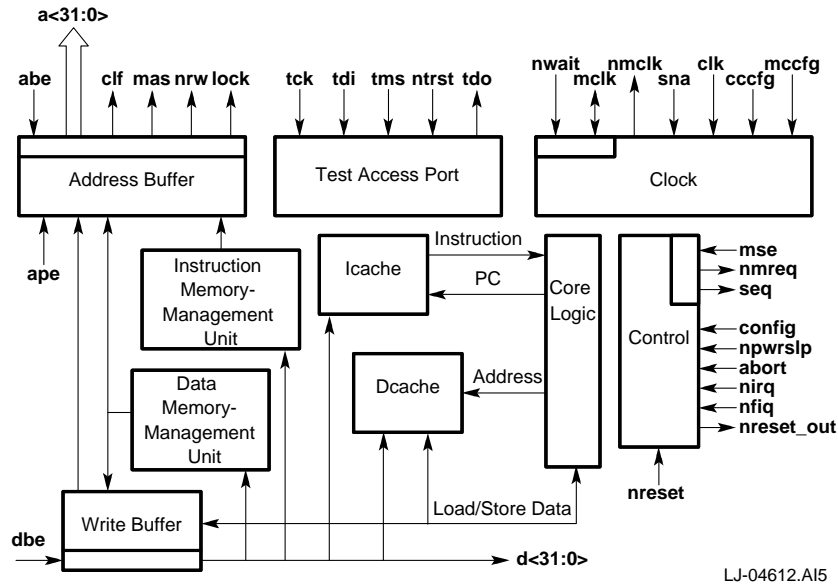

Bus Interface Logic

The bus interface logic, consisting of the control logic and the address register, controls the bus interface and unplanned events such as interrupts, resets, and aborts. The bus interface logic can also enable or disable wrapping of read transactions and merging of write transactions.

The bus interface can be configured to run synchronously or asynchronously to the core logic. In synchronous mode, the bus interface clock speed is the core clock rate divided by a programmable integer value from 2 to 9 (maximum of 66 MHz).

Write Buffer

The SA-110 has an 8-entry write buffer with each entry able to contain 1 byte to 16 bytes. The write buffer can be enabled or disabled by software. The write buffer is further controlled by a bit in the MMU page tables; so the MMU must be enabled before the write buffer can be used. Software can cause the write buffer to be flushed.

Core Logic

The core logic fetches and executes instructions by using a five-stage pipeline. The five stages are: fetch, decode, arithmetic logic unit (ALU), cache, and write-back. This pipeline arrangement, using the on-chip ALU, distributes tasks evenly in time and, therefore, contributes to the high performance of the core logic.

The ARM** architecture supports 30 general-purpose registers, one program counter, and six status registers. There are 16 general-purpose registers (including the PC register) and one or two status registers visible at any one time. The processor operating mode determines which registers are visible.

The core logic executes the ARM** instruction set, which supports straight-forward assembly language code programming. It does not depend upon sophisticated compilers to manage complicated instruction interdependence. The instruction set has eight instruction classes:

- Two instruction classes use the on-chip ALU, barrel shifter, and multiplier to perform high-speed operations on the data in a bank of 16 logical (31 physical) 32-bit registers.
- Three instruction classes control data transfer between memory and the registers. The classes are optimized for flexible addressing, rapid context switching, and swapping data.
- Two instruction classes control execution flow and execution privilege level.
- One instruction class accesses the privileged state of the SA-110.

The core logic implements 32-bit virtual addresses and 32-bit physical addresses. A 12-bit multiplier with early termination performs multiplication. The number of cycles needed to perform a multiplication operation depends on the magnitude of the operands, as shown in Table 1.

Table 1. Core Logic Multiplication Functions

Multiplication Operation (Signed or Unsigned)	Result Size	Operation Duration
32 x 32	32 bits	2–4 cycles
32 x 32 + 32	32 bits	2–4 cycles
32 x 32	64 bits	3–5 cycles
32 x 32 + 64	64 bits	3–5 cycles

Memory-Management Units

The SA-110 has two MMUs: instruction (IMMU) and data (DMMU). Separate translation look-aside buffers (TLBs) are implemented for the instruction and data streams. The TLBs each have 32 entries that can each map a segment, a large page, or a small page. The TLB entry replacement algorithm is round robin. The data TLB supports both the flush-all and the flush-single-entry function, while the instruction TLB supports only the flush-all function. Memory-management exceptions preserve the base address registers, eliminating the need for “fix-up” code.

Cache

The SA-110 has a 16 Kbyte, 32-way, set-associative Icache with 32-byte blocks and a 16 Kbyte, 32-way, set-associative, write-back Dcache with 32-byte blocks.

Instruction Cache

The Icache supports the flush-all-entry function, and the replacement algorithm is round-robin within a set. The Icache can be enabled or disabled independent of the memory-management function. When memory management is disabled, the Icache control logic considers all memory to be cacheable.

Data Cache

The write-back Dcache supports the flush-all-entry, flush-entry, and copyback-entry functions. The copyback-all function is not provided in hardware but can be provided by software. The Dcache entries are allocated with read transactions and the entry replacement logic uses a round-robin algorithm.

Clocks

The SA-110 receives a 3.68-MHz clock from a crystal-based clock generator. The SA-110 uses an internal PLL to multiply the frequency by a variable multiplier to produce a high-speed clock. The high-speed clock is then divided internally by a configurable ratio to provide a system clock for synchronous operation. The 3.68-MHz oscillator and PLL run constantly in normal and idle mode.

Boundary-Scan Test Logic

The SA-110 boundary-scan interface provides for driving and sampling of all the external pins of the device except **npwrslp**, irrespective of the core logic state. This ability permits testing of:

- SA-110 electrical connections to the circuit board.
- Integrity of connections between devices having a similar interface on the circuit board.

Signal Lines

Figure 2 shows the signal connects to and from the SA-110. The signals are arranged within functional groups.

Figure 2. Functional Group Signal Lines

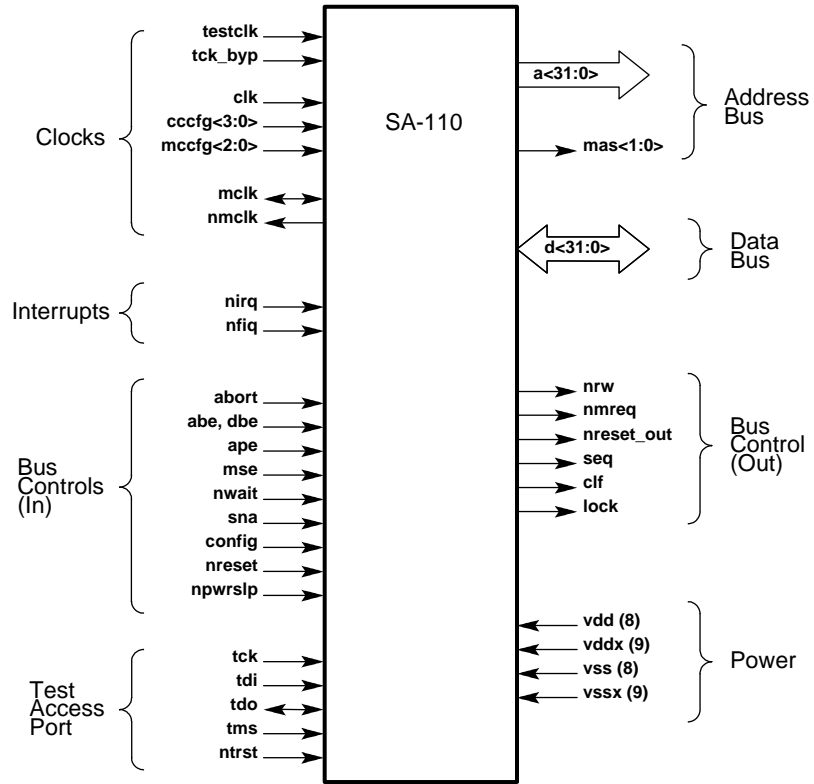

LJ-04613.AI5

Table 2. SA-110 Characteristics

	110 MHz	160 MHz	166 MHz	200 MHz	233 MHz
Performance	115 Dhrystone 2.1 MIPS	185 Dhrystone 2.1 MIPS	192 Dhrystone 2.1 MIPS	230 Dhrystone 2.1 MIPS	268 Dhrystone 2.1 MIPS
Core power supply	Vss = 0.0 V dc Vdd = 1.65 V dc \pm 10%	Vss = 0.0 V dc Vdd = 1.65 V dc \pm 10%	Vss = 0.0 V dc Vdd = 2.0 V dc \pm 10%	Vss = 0.0 V dc Vdd = 2.0 V dc \pm 10%	Vss = 0.0 V dc Vdd = 2.0 V dc \pm 10%
I/O power supply	Vssx = 0.0 V dc Vddx = 3.3 V dc \pm 10%	Vssx = 0.0 V dc Vddx = 3.3 V dc \pm 10%	Vssx = 0.0 V dc Vddx = 3.3 V dc \pm 10%	Vss = 0.0 V dc Vdd = 3.3 V dc \pm 10%	Vss = 0.0 V dc Vdd = 3.3 V dc \pm 10%
Power dissipation	Maximum = <450 mW Typical = <110 mW	Maximum = <900 mW Typical = <136 mW	Maximum = <450 mW	Maximum = <900 mW	Maximum = <1000 mW
Modes	Sleep current = 50 μ A Idle power = <20 mW	Sleep current = 50 μ A Idle power = <20 mW	—	—	—
Operating temperature	Tj = 100°C (212°F)	Tj = 100°C (212°F)	Tj = 100°C (212°F)	Tj = 100°C (212°F)	Tj = 100°C (212°F)
Storage temperature	-40°C to +125°C (-40°F to +257°F)	-40°C to +125°C (-40°F to +257°F)	-40°C to +125°C (-40°F to +257°F)	-40°C to +125°C (-40°F to +257°F)	-40°C to +125°C (-40°F to +257°F)
Packaging	144-pin TQFP	144-pin TQFP	144-pin TQFP	144-pin TQFP	144-pin TQFP
Process technology	.35 μ m, 3-layer metal	.35 μ m, 3-layer metal	.35 μ m, 3-layer metal	.35 μ m, 3-layer metal	.35 μ m, 3-layer metal
Transistor count	2.1 million	2.1 million	2.1 million	2.1 million	2.1 million
Order number	21281-BA	21281-AA	21281-DA	21281-CA	21281-EA

Support, Products, and Documentation

If you need technical support, a *Product Catalog*, or help deciding which documentation best meets your needs, visit the Intel World Wide Web Internet site:

<http://www.intel.com>

Copies of documents that have an ordering number and are referenced in this document, or other Intel literature may be obtained by calling **1-800-332-2717** or by visiting Intel's website for developers at:

<http://developer.intel.com>

You can also contact the Intel Massachusetts Information Line or the Intel Massachusetts Customer Technology Center. Please use the following information lines for support:

For documentation and general information:	
Intel Massachusetts Information Line	
United States:	1-800-332-2717
Outside United States:	1-303-675-2148
Electronic mail address:	techdoc@intel.com
For technical support:	
Intel Massachusetts Customer Technology Center	
Phone (U.S. and international):	1-978-568-7474
Fax:	1-978-568-6698
Electronic mail address:	techsup@intel.com

