



80960JA/JF/JD/JT 3.3 V Embedded 32-Bit Microprocessor

Preliminary Datasheet

Product Features

- Pin/Code Compatible with all 80960Jx Processors
- High-Performance Embedded Architecture
 - One Instruction/Clock Execution
 - Core Clock Rate is:
 - 80960JA/JF 1x the Bus Clock
 - 80960JD 2x the Bus Clock
 - 80960JT 3x the Bus Clock
 - Load/Store Programming Model
 - Sixteen 32-Bit Global Registers
 - Sixteen 32-Bit Local Registers (8 sets)
 - Nine Addressing Modes
 - User/Supervisor Protection Model
- Two-Way Set Associative Instruction Cache
 - 80960JA - 2 Kbyte
 - 80960JF/JD - 4 Kbyte
 - 80960JT - 16 Kbyte
 - Programmable Cache-Locking Mechanism
- Direct Mapped Data Cache
 - 80960JA - 1 Kbyte
 - 80960JF/JD - 2 Kbyte
 - 80960JT - 4 Kbyte
 - Write Through Operation
- On-Chip Stack Frame Cache
 - Seven Register Sets Can Be Saved
 - Automatic Allocation on Call/Return
 - 0-7 Frames Reserved for High-Priority Interrupts
- On-Chip Data RAM
 - 1 Kbyte Critical Variable Storage
 - Single-Cycle Access
- 3.3 V Supply Voltage
 - 5 V Tolerant Inputs
 - TTL Compatible Outputs
- High Bandwidth Burst Bus
 - 32-Bit Multiplexed Address/Data
 - Programmable Memory Configuration
 - Selectable 8-, 16-, 32-Bit Bus Widths
 - Supports Unaligned Accesses
 - Big or Little Endian Byte Ordering
- High-Speed Interrupt Controller
 - 31 Programmable Priorities
 - Eight Maskable Pins plus NMI#
 - Up to 240 Vectors in Expanded Mode
- Two On-Chip Timers
 - Independent 32-Bit Counting
 - Clock Prescaling by 1, 2, 4 or 8
 - Internal Interrupt Sources
- Halt Mode for Low Power
- IEEE 1149.1 (JTAG) Boundary Scan Compatibility
- Packages
 - 132-Lead Pin Grid Array (PGA)
 - 132-Lead Plastic Quad Flat Pack (PQFP)
 - 196-Ball Mini Plastic Ball Grid Array (MPBGA)

Notice: This document contains preliminary information on new products in production. The specifications are subject to change without notice. Verify with your local Intel sales office that you have the latest datasheet before finalizing a design.



Information in this document is provided in connection with Intel products. No license, express or implied, by estoppel or otherwise, to any intellectual property rights is granted by this document. Except as provided in Intel's Terms and Conditions of Sale for such products, Intel assumes no liability whatsoever, and Intel disclaims any express or implied warranty, relating to sale and/or use of Intel products including liability or warranties relating to fitness for a particular purpose, merchantability, or infringement of any patent, copyright or other intellectual property right. Intel products are not intended for use in medical, life saving, or life sustaining applications.

Intel may make changes to specifications and product descriptions at any time, without notice.

Designers must not rely on the absence or characteristics of any features or instructions marked "reserved" or "undefined." Intel reserves these for future definition and shall have no responsibility whatsoever for conflicts or incompatibilities arising from future changes to them.

The 80960JA/JF/JD/JT 3.3 V microprocessors may contain design defects or errors known as errata which may cause the products to deviate from published specifications. Current characterized errata are available on request.

Contact your local Intel sales office or your distributor to obtain the latest specifications and before placing your product order.

Copies of documents which have an ordering number and are referenced in this document, or other Intel literature may be obtained by calling 1-800-548-4725 or by visiting Intel's website at <http://www.intel.com>.

Copyright © Intel Corporation, 1998

*Third-party brands and names are the property of their respective owners.

Contents

1.0	Introduction	7
2.0	80960Jx Overview	8
2.1	80960 Processor Core	10
2.2	Burst Bus	10
2.3	Timer Unit	11
2.4	Priority Interrupt Controller	11
2.5	Instruction Set Summary	11
2.6	Faults and Debugging	12
2.7	Low Power Operation	12
2.8	Test Features	12
2.9	Memory-Mapped Control Registers	12
2.10	Data Types and Memory Addressing Modes	13
3.0	Packaging Information: 80960Jx 3.3 V Processors	15
3.1	Pin Descriptions	16
3.1.1	Functional Pin Definitions	16
3.1.2	80960Jx 132-Lead PGA Pinout	22
3.1.3	80960Jx 132-Lead PQFP Pinout	26
3.1.4	80960Jx 196-Ball MPBGA Pinout	29
3.2	Package Thermal Specifications	34
3.3	Thermal Management Accessories	38
3.3.1	Heatsinks	38
4.0	Electrical Specifications: 80960Jx 3.3 V Processors	39
4.1	Absolute Maximum Ratings	39
4.2	Operating Conditions	39
4.3	Connection Recommendations	40
4.4	VCC5 Pin Requirements (VDIFF)	40
4.5	VCCPLL Pin Requirements	41
4.6	DC Specifications	42
4.7	AC Specifications	44
4.7.1	AC Test Conditions and Derating Curves	47
4.7.2	AC Timing Waveforms	53
5.0	Bus Functional Waveforms	59
5.1	Basic Bus States	69
5.2	Boundary-Scan Register	70
6.0	Device Identification: 80960Jx 3.3 V Processors	76
7.0	Revision History	80

Figures

1	80960Jx Microprocessor Package Options.....	7
2	80960Jx Block Diagram	9
3	132-Lead Pin Grid Array Top View - Pins Facing Down	22
4	132-Lead Pin Grid Array Bottom View - Pins Facing Up.....	23
5	132-Lead PQFP - Top View	26
6	196-Ball Mini Plastic Ball Grid Array Top View - Balls Facing Down	29
7	196-Ball Mini Plastic Ball Grid Array Bottom View - Balls Facing Up.....	30
8	VCC5 Current-Limiting Resistor.....	40
9	VCCPLL Lowpass Filter.....	41
10	AC Test Load	47
11	Output Delay or Hold vs. Load Capacitance – 80960JT Processor (3.3 V Signals).....	47
12	Output Delay or Hold vs. Load Capacitance – 80960JT Processor (5 V Signals).....	47
13	Output Delay or Hold vs. Load Capacitance – 80960JA/JF/JD Processors	48
14	T _{LX} vs. AD Bus Load Capacitance – 80960JT Processor (3.3 V Signals).....	48
15	T _{LX} vs. AD Bus Load Capacitance – 80960JT Processor (5 V Signals).....	49
16	T _{LX} vs. AD Bus Load Capacitance – 80960JA/JF/JD Processors	49
17	80960JA/JF I _{CC} Active (Power Supply) vs. Frequency.....	50
18	80960JA/JF I _{CC} Active (Thermal) vs. Frequency.....	50
19	80960JD I _{CC} Active (Power Supply) vs. Frequency.....	51
20	80960JD I _{CC} Active (Thermal) vs. Frequency.....	51
21	80960JT I _{CC} Active (Power Supply) vs. Frequency	52
22	80960JT I _{CC} Active (Thermal) vs. Frequency	52
23	CLKIN Waveform	53
24	T _{OV1} Output Delay Waveform	53
25	T _{OF} Output Float Waveform.....	54
26	T _{IS1} and T _{IH1} Input Setup and Hold Waveform.....	54
27	T _{IS2} and T _{IH2} Input Setup and Hold Waveform.....	54
28	T _{IS3} and T _{IH3} Input Setup and Hold Waveform.....	55
29	T _{IS4} and T _{IH4} Input Setup and Hold Waveform.....	55
30	T _{LX} , T _{LXL} and T _{LXA} Relative Timings Waveform.....	56
31	DT/R# and DEN# Timings Waveform	56
32	TCK Waveform.....	57
33	T _{BIS1} and T _{BSIH1} Input Setup and Hold Waveforms	57
34	T _{BISOV1} and T _{BSOF1} Output Delay and Output Float Waveform.....	57
35	T _{BISOV2} and T _{BSOF2} Output Delay and Output Float Waveform.....	58
36	T _{BIS2} and T _{BSIH2} Input Setup and Hold Waveform	58
37	Non-Burst Read and Write Transactions Without Wait States, 32-Bit Bus	59
38	Burst Read and Write Transactions Without Wait States, 32-Bit Bus	60
39	Burst Write Transactions With 2,1,1,1 Wait States, 32-Bit Bus.....	61
40	Burst Read and Write Transactions Without Wait States, 8-Bit Bus	62
41	Burst Read and Write Transactions With 1, 0 Wait States and Extra Tr State on Read, 16-Bit Bus.....	63
42	Double Word Read Bus Request, Misaligned One Byte From Quad Word Boundary, 32-Bit Bus, Little Endian	64
43	HOLD/HOLDA Waveform For Bus Arbitration	65
44	Cold Reset Waveform	66
45	Warm Reset Waveform.....	67

46	Entering the ONCE State	68
47	Bus States with Arbitration	70
48	Summary of Aligned and Unaligned Accesses (32-Bit Bus)	74
49	Summary of Aligned and Unaligned Accesses (32-Bit Bus)	75
50	80960JT Device Identification Register	76
51	80960JD Device Identification Register	77
52	80960JA/JF Device Identification Register	78

Tables

1	80960Jx Instruction Set	14
2	Pin Description Nomenclature	16
3	Pin Description — External Bus Signals	17
4	Pin Description — Processor Control Signals, Test Signals and Power	20
5	Pin Description — Interrupt Unit Signals	21
6	132-Lead PGA Pinout — In Signal Order	24
7	132-Lead PGA Pinout — In Pin Order	25
8	132-Lead PQFP Pinout — In Signal Order	27
9	132-Lead PQFP Pinout — In Pin Order	28
10	196-Ball MPBGA Pinout — In Signal Order	31
11	196-Ball MPBGA Pinout — In Pin Order	32
12	132-Lead PGA Package Thermal Characteristics	35
13	196-Ball MPBGA Package Thermal Characteristics	35
14	132-Lead PQFP Package Thermal Characteristics	36
15	Maximum T_A at Various Airflows in °C (80960JT)	36
16	Maximum T_A at Various Airflows in °C (80960JD)	37
17	Maximum T_A at Various Airflows in °C (80960JA/JF)	37
18	Absolute Maximum Ratings	39
19	80960Jx Operating Conditions	39
20	V _{DIFF} Parameters	41
21	80960Jx DC Characteristics	42
22	80960Jx I_{CC} Characteristics	42
23	80960Jx AC Characteristics	44
24	Note Definitions for Table 23, 80960Jx AC Characteristics	46
25	Boundary-Scan Register Bit Order	71
26	Natural Boundaries for Load and Store Accesses	72
27	Summary of Byte Load and Store Accesses	72
28	Summary of Short Word Load and Store Accesses	72
29	Summary of n-Word Load and Store Accesses (n = 1, 2, 3, 4)	73
30	80960Jx Device Type and Stepping Reference	76
31	Fields of 80960JT Device ID	77
32	80960JT Device ID Model Types	77
33	Fields of 80960JD Device ID	78
34	80960JD Device ID Model Types	78
35	Fields of 80960JA/JF Device ID	79
36	80960JA/JF Device ID Model Types	79
37	Data Sheet Revision History	80

1.0 Introduction

This document contains information for the 80960Jx microprocessor, including electrical characteristics and package pinout information. Detailed functional descriptions — other than parametric performance — are published in the *i960[®] Jx Microprocessor Developer's Manual* (272483).

Figure 1. 80960Jx Microprocessor Package Options

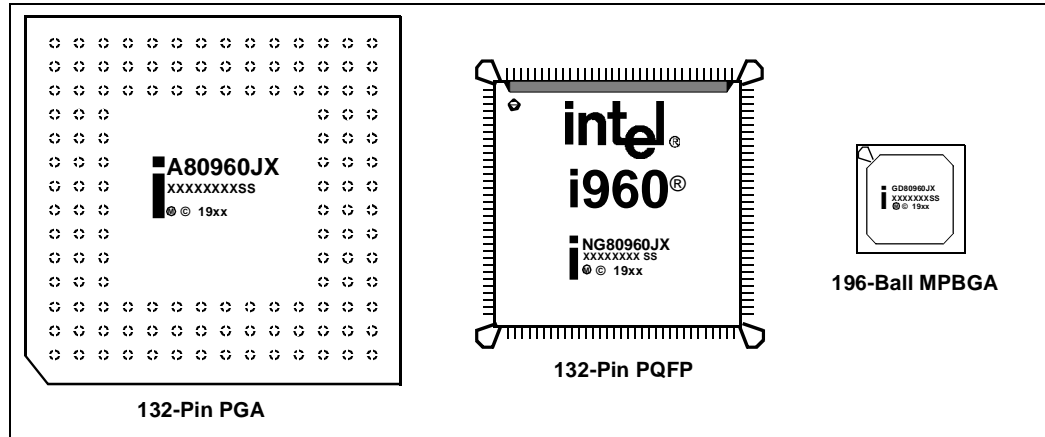

Throughout this data sheet, references to “80960Jx” indicate features that apply to all of the following:

- 80960JA — 3.3 V (5 V Tolerant), 2 Kbyte instruction cache, 1 Kbyte data cache
- 80960JF — 3.3 V (5 V Tolerant), 4 Kbyte instruction cache, 2 Kbyte data cache
- 80960JD — 3.3 V (5 V Tolerant), 4 Kbyte instruction cache, 2 Kbyte data cache and clock doubling
- 80960JT — 3.3 V (5 V Tolerant), 16 Kbyte instruction cache, 4 Kbyte data cache and clock tripling

2.0 80960Jx Overview

The 80960Jx offers high performance to cost-sensitive 32-bit embedded applications. The 80960Jx is object code compatible with the 80960 Core Architecture and is capable of sustained execution at the rate of one instruction per clock. This processor's features include generous instruction cache, data cache and data RAM. It also boasts a fast interrupt mechanism and dual-programmable timer units.

The 80960Jx's clock multiplication operates the processor core at two or three times the bus clock rate to improve execution performance without increasing the complexity of board designs.

Memory subsystems for cost-sensitive embedded applications often impose substantial wait state penalties. The 80960Jx integrates considerable storage resources on-chip to decouple CPU execution from the external bus.

The 80960Jx rapidly allocates and deallocates local register sets during context switches. The processor needs to flush a register set to the stack only when it saves more than seven sets to its local register cache.

A 32-bit multiplexed burst bus provides a high-speed interface to system memory and I/O. A full complement of control signals simplifies the connection of the 80960Jx to external components. The user programs physical and logical memory attributes through memory-mapped control registers (MMRs) — an extension not found on the i960 Kx, Sx or Cx processors. Physical and logical configuration registers enable the processor to operate with all combinations of bus width and data object alignment. The processor supports a homogeneous byte ordering model.

This processor integrates two important peripherals: a timer unit, and an interrupt controller. These and other hardware resources are programmed through memory-mapped control registers, an extension to the familiar 80960 architecture.

The timer unit (TU) offers two independent 32-bit timers for use as real-time system clocks and general-purpose system timing. These operate in either single-shot or auto-reload mode and can generate interrupts.

The interrupt controller unit (ICU) provides a flexible, low-latency means for requesting interrupts. The ICU provides full programmability of up to 240 interrupt sources into 31 priority levels. The ICU takes advantage of a cached priority table and optional routine caching to minimize interrupt latency. Clock doubling reduces interrupt latency by 40% compared to the 80960JA/JF, and clock tripling reduces interrupt latency by 20% compared to the 80960JD. Local registers may be dedicated to high-priority interrupts to further reduce latency. Acting independently from the core, the ICU compares the priorities of posted interrupts with the current process priority, off-loading this task from the core. The ICU also supports the integrated timer interrupts.

The 80960Jx features a Halt mode designed to support applications where low power consumption is critical. The **halt** instruction shuts down instruction execution, resulting in a power savings of up to 90 percent.

The 80960Jx's testability features, including ONCE (On-Circuit Emulation) mode and Boundary Scan (JTAG), provide a powerful environment for design debug and fault diagnosis.

The *Solutions960*[®] program features a wide variety of development tools which support the i960 processor family. Many of these tools are developed by partner companies; some are developed by Intel, such as profile-driven optimizing compilers. For more information on these products, contact your local Intel representative.

Figure 2. 80960Jx Block Diagram

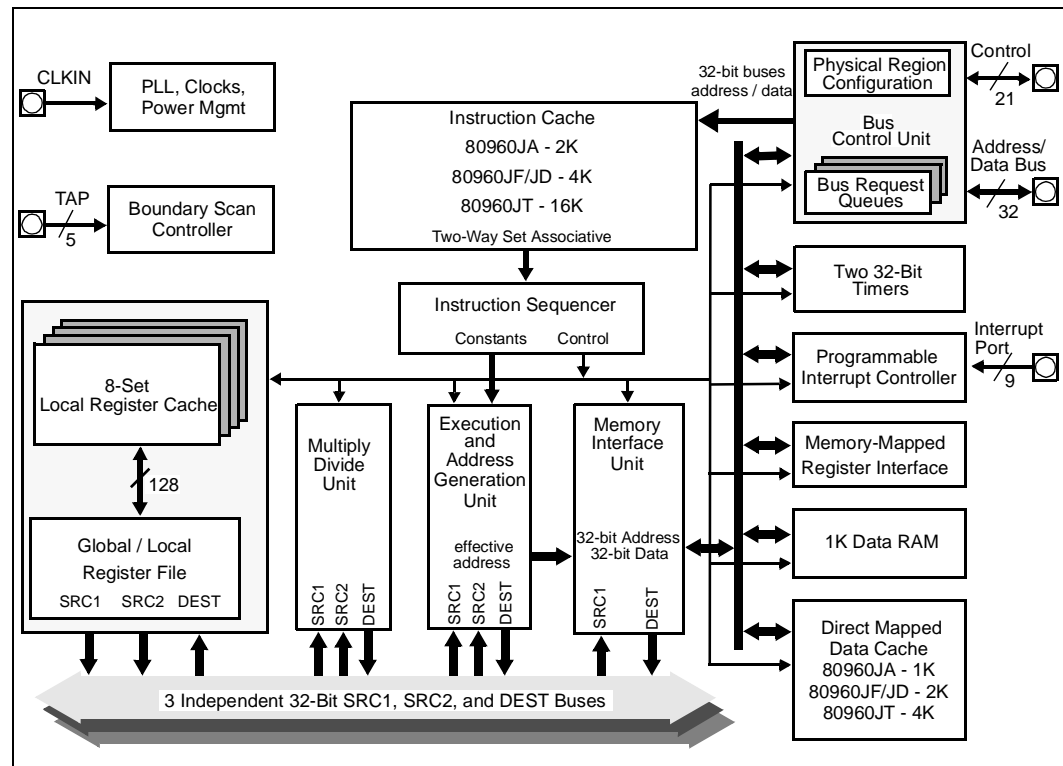

2.1 80960 Processor Core

The 80960Jx family is a scalar implementation of the 80960 Core Architecture. Intel designed this processor core as a very high performance device that is also cost-effective. Factors that contribute to the core's performance include:

- Core operates at the bus speed with the 80960JA/JF
- Core operates at two or three times the bus speed with the 80960JD and 80960JT respectively
- Single-clock execution of most instructions
- Independent Multiply/Divide Unit
- Efficient instruction pipeline minimizes pipeline break latency
- Register and resource scoreboarding allow overlapped instruction execution
- 128-bit register bus speeds local register caching
- Two-way set associative, integrated instruction cache
- Direct-mapped, integrated data cache
- 1 Kbyte integrated data RAM delivers zero wait state program data

2.2 Burst Bus

A 32-bit high-performance Bus Controller Unit (BCU) interfaces the 80960Jx to external memory and peripherals. The BCU fetches instructions and transfers data at the rate of up to four 32-bit words per six clock cycles. The external address/data bus is multiplexed.

Users may configure the 80960Jx's bus controller to match an application's fundamental memory organization. Physical bus width is register-programmed for up to eight regions. Byte ordering and data caching are programmed through a group of logical memory templates and a defaults register.

The BCU's features include:

- Multiplexed external bus to minimize pin count
- 32-, 16- and 8-bit bus widths to simplify I/O interfaces
- External ready control for address-to-data, data-to-data and data-to-next-address wait state types
- Support for big or little endian byte ordering to facilitate the porting of existing program code
- Unaligned bus accesses performed transparently
- Three-deep load/store queue to decouple the bus from the core

Upon reset, the 80960Jx conducts an internal self-test. Then, before executing its first instruction, it performs an external bus confidence test by performing a checksum on the first words of the initialization boot record (IBR).

The user may examine the contents of the caches by executing special cache control instructions.

2.3 Timer Unit

The timer unit (TU) contains two independent 32-bit timers that are capable of counting at several clock rates and generating interrupts. Each is programmed by use of the TU registers. These memory-mapped registers are addressable on 32-bit boundaries. The timers have a single-shot mode and auto-reload capabilities for continuous operation. Each timer has an independent interrupt request to the 80960Jx's interrupt controller. The TU can generate a fault when unauthorized writes from user mode are detected. Clock prescaling is supported.

2.4 Priority Interrupt Controller

A programmable interrupt controller manages up to 240 external sources through an 8-bit external interrupt port. Alternatively, the interrupt inputs may be configured for individual edge- or level-triggered inputs. The interrupt unit (IU) also accepts interrupts from the two on-chip timer channels and a single Non-Maskable Interrupt (NMI#) pin. Interrupts are serviced according to their priority levels relative to the current process priority.

Low interrupt latency is critical to many embedded applications. As part of its highly flexible interrupt mechanism, the 80960Jx exploits several techniques to minimize latency:

- Interrupt vectors and interrupt handler routines can be reserved on-chip
- Register frames for high-priority interrupt handlers can be cached on-chip
- The interrupt stack can be placed in cacheable memory space
- Interrupt microcode executes at two or three times the bus frequency for the 80960JD and 80960JT respectively

2.5 Instruction Set Summary

The 80960Jx adds several new instructions to the i960 core architecture. The new instructions are:

- Conditional Move
- Conditional Add
- Conditional Subtract
- Byte Swap
- Halt
- Cache Control
- Interrupt Control

Table 1 identifies the instructions that the 80960Jx supports. Refer to the *i960® Jx Microprocessor Developer's Manual (272483)* for a detailed description of each instruction.

2.6 Faults and Debugging

The 80960Jx employs a comprehensive fault model. The processor responds to faults by making implicit calls to a fault handling routine. Specific information collected for each fault allows the fault handler to diagnose exceptions and recover appropriately.

The processor also has built-in debug capabilities. In software, the 80960Jx may be configured to detect as many as seven different trace event types. Alternatively, **mark** and **fmark** instructions can generate trace events explicitly in the instruction stream. Hardware breakpoint registers are also available to trap on execution and data addresses.

2.7 Low Power Operation

Intel fabricates the 80960Jx using an advanced sub-micron manufacturing process. The processor's sub-micron topology provides the circuit density for optimal cache size and high operating speeds while dissipating modest power. The processor also uses dynamic power management to turn off clocks to unused circuits.

Users may program the 80960Jx to enter Halt mode for maximum power savings. In Halt mode, the processor core stops completely while the integrated peripherals continue to function, reducing overall power requirements up to 90 percent. Processor execution resumes from internally or externally generated interrupts.

2.8 Test Features

The 80960Jx incorporates numerous features which enhance the user's ability to test both the processor and the system to which it is attached. These features include ONCE (On-Circuit Emulation) mode and Boundary Scan (JTAG).

The 80960Jx provides testability features compatible with IEEE Standard Test Access Port and Boundary Scan Architecture (IEEE Std. 1149.1).

One of the boundary scan instructions, **HIGHZ**, forces the processor to float all its output pins (ONCE mode). ONCE mode can also be initiated at reset without using the boundary scan mechanism.

ONCE mode is useful for board-level testing. This feature allows a mounted 80960Jx to electrically "remove" itself from a circuit board. This allows for system-level testing where a remote tester — such as an in-circuit emulator — can exercise the processor system.

The provided test logic does not interfere with component or circuit board behavior and ensures that components function correctly, connections between various components are correct, and various components interact correctly on the printed circuit board.

The JTAG Boundary Scan feature is an attractive alternative to conventional "bed-of-nails" testing. It can examine connections which might otherwise be inaccessible to a test system.

2.9 Memory-Mapped Control Registers

The 80960Jx, though compliant with i960 series processor core, has the added advantage of memory-mapped, internal control registers not found on the i960 Kx, Sx or Cx processors. These give software the interface to easily read and modify internal control registers.

Each of these registers is accessed as a memory-mapped, 32-bit register. Access is accomplished through regular memory-format instructions. The processor ensures that these accesses do not generate external bus cycles.

2.10 Data Types and Memory Addressing Modes

As with all i960 family processors, the 80960Jx instruction set supports several data types and formats:

- Bit
- Bit fields
- Integer (8-, 16-, 32-, 64-bit)
- Ordinal (8-, 16-, 32-, 64-bit unsigned integers)
- Triple word (96 bits)
- Quad word (128 bits)

The 80960Jx provides a full set of addressing modes for C and assembly programming:

- Two Absolute modes
- Five Register Indirect modes
- Index with displacement
- IP with displacement

Table 1. 80960Jx Instruction Set

Data Movement	Arithmetic	Logical	Bit, Bit Field and Byte
Load Store Move *Conditional Select Load Address	Add Subtract Multiply Divide Remainder Modulo Shift Extended Shift Extended Multiply Extended Divide Add with Carry Subtract with Carry *Conditional Add *Conditional Subtract Rotate	And Not And And Not Or Exclusive Or Not Or Or Not Nor Exclusive Nor Not Nand	Set Bit Clear Bit Not Bit Alter Bit Scan For Bit Span Over Bit Extract Modify Scan Byte for Equal *Byte Swap
Comparison	Branch	Call/Return	Fault
Compare Conditional Compare Compare and Increment Compare and Decrement Test Condition Code Check Bit	Unconditional Branch Conditional Branch Compare and Branch	Call Call Extended Call System Return Branch and Link	Conditional Fault Synchronize Faults
Debug	Processor Management	Atomic	
Modify Trace Controls Mark Force Mark	Flush Local Registers Modify Arithmetic Controls Modify Process Controls *Halt System Control *Cache Control *Interrupt Control	Atomic Add Atomic Modify	

Asterisk (*) denotes new 80960Jx instructions unavailable on 80960CA/CF, 80960KA/KB and 80960SA/SB implementations.

3.0 Packaging Information: 80960Jx 3.3 V Processors

The 80960Jx is offered with four speeds and three package types. The 132-pin Pin Grid Array (PGA) device is specified for operation at $V_{CC} = 3.3 \text{ V} \pm 0.15 \text{ V}$ over a case temperature range of 0° to 100°C :

- A80960JT-100 (100 MHz core, 33 MHz bus)
- A80960JD-66 (66 MHz core, 33 MHz bus)
- A80960JD-50 (50 MHz core, 25 MHz bus)
- A80960JD-40 (40 MHz core, 20 MHz bus)
- A80960JD-33 (33 MHz core, 16 MHz bus)
- A80960JA/JF-33 (33 MHz)
- A80960JA/JF-25 (25 MHz)
- A80960JA/JF-16 (16 MHz)

The 132-pin Plastic Quad Flatpack (PQFP) devices are specified for operation at $V_{CC} = 3.3 \text{ V} \pm 0.15 \text{ V}$ over a case temperature range of 0° to 100°C :

- NG80960JT-100 (100 MHz core, 33 MHz bus)
- NG80960JD-66 (66 MHz core, 33 MHz bus)
- NG80960JD-50 (50 MHz core, 25 MHz bus)
- NG80960JD-40 (40 MHz core, 20 MHz bus)
- NG80960JD-33 (33 MHz core, 16 MHz bus)
- NG80960JA/JF-33 (33 MHz)
- NG80960JA/JF-25 (25 MHz)
- NG80960JA/JF-16 (16 MHz)

An extended temperature 132-pin Plastic Quad Flatpack (PQFP) device is specified for operation at $V_{CC} = 3.3 \text{ V} \pm 0.15 \text{ V}$ over a case temperature range of -40° to 100°C :

- TG80960JA-25 (25 MHz)

The 196-ball Mini Plastic Ball Grid Array (MPBGA) device is specified for operation at $V_{CC} = 3.3 \text{ V} \pm 0.15 \text{ V}$ over a case temperature range of 0° to 100°C :

- GD80960JT-100 (100 MHz core, 33 MHz bus)
- GD80960JD-50 (50 MHz core, 25 MHz bus)
- GD80960JD-40 (40 MHz core, 20 MHz bus)
- GD80960JD-33 (33 MHz core, 16 MHz bus)
- GD80960JA/JF-33 (33 MHz)
- GD80960JA/JF-25 (25 MHz)
- GD80960JA/JF-16 (16 MHz)

For package specifications and information, refer to Intel's *Packaging Handbook* (240800).

3.1 Pin Descriptions

This section describes the pins for the 80960Jx in the 132-pin ceramic Pin Grid Array (PGA) package, 132-lead Plastic Quad Flatpack Package (PQFP) and 196-ball Mini Plastic Ball Grid Array (MPBGA).

Section 3.1.1, “Functional Pin Definitions”, describes pin function; Section 3.1.2, “80960Jx 132-Lead PGA Pinout”, Section 3.1.3, “80960Jx 132-Lead PQFP Pinout” and Section 3.1.4, “80960Jx 196-Ball MPBGA Pinout”, define the signal and pin locations for the supported package types.

3.1.1 Functional Pin Definitions

Table 2 presents the legend for interpreting the pin descriptions which follow. Pins associated with the bus interface are described in Table 3. Pins associated with basic control and test functions are described in Table 4. Pins associated with the Interrupt Unit are described in Table 5.

Table 2. Pin Description Nomenclature

Symbol	Description
I	Input pin only.
O	Output pin only.
I/O	Pin can be either an input or output.
–	Pin must be connected as described.
S	Synchronous. Inputs must meet setup and hold times relative to CLKIN for proper operation. S(E) Edge sensitive input S(L) Level sensitive input
A (...)	Asynchronous. Inputs may be asynchronous relative to CLKIN. A(E) Edge sensitive input A(L) Level sensitive input
R (...)	While the processor's RESET# pin is asserted, the pin: R(1) is driven to V_{CC} R(0) is driven to V_{SS} R(Q) is a valid output R(X) is driven to unknown state R(H) is pulled up to V_{CC}
H (...)	While the processor is in the hold state, the pin: H(1) is driven to V_{CC} H(0) is driven to V_{SS} H(Q) Maintains previous state or continues to be a valid output H(Z) Floats
P (...)	While the processor is halted, the pin: P(1) is driven to V_{CC} P(0) is driven to V_{SS} P(Q) Maintains previous state or continues to be a valid output

Table 3. Pin Description — External Bus Signals (Sheet 1 of 4)

NAME	TYPE	DESCRIPTION															
AD[31:0]	I/O S(L) R(X) H(Z) P(Q)	<p>ADDRESS / DATA BUS carries 32-bit physical addresses and 8-, 16- or 32-bit data to and from memory. During an address (T_a) cycle, bits 31:2 contain a physical word address (bits 0-1 indicate SIZE; see below). During a data (T_d) cycle, read or write data is present on one or more contiguous bytes, comprising AD[31:24], AD[23:16], AD[15:8] and AD[7:0]. During write operations, unused pins are driven to determinate values.</p> <p>SIZE, which comprises bits 0-1 of the AD lines during a T_a cycle, specifies the number of data transfers during the bus transaction.</p> <table border="1"> <thead> <tr> <th>AD1</th> <th>AD0</th> <th>Bus Transfers</th> </tr> </thead> <tbody> <tr> <td>0</td> <td>0</td> <td>1 Transfer</td> </tr> <tr> <td>0</td> <td>1</td> <td>2 Transfers</td> </tr> <tr> <td>1</td> <td>0</td> <td>3 Transfers</td> </tr> <tr> <td>1</td> <td>1</td> <td>4 Transfers</td> </tr> </tbody> </table> <p>When the processor enters Halt mode, if the previous bus operation was a:</p> <ul style="list-style-type: none"> write — AD[31:2] are driven with the last data value on the AD bus. read — AD[31:4] are driven with the last address value on the AD bus; AD[3:2] are driven with the value of A[3:2] from the last data cycle. <p>Typically, AD[1:0] reflect the SIZE information of the last bus transaction (either instruction fetch or load/store) that was executed before entering Halt mode.</p>	AD1	AD0	Bus Transfers	0	0	1 Transfer	0	1	2 Transfers	1	0	3 Transfers	1	1	4 Transfers
AD1	AD0	Bus Transfers															
0	0	1 Transfer															
0	1	2 Transfers															
1	0	3 Transfers															
1	1	4 Transfers															
ALE	O R(0) H(Z) P(0)	ADDRESS LATCH ENABLE indicates the transfer of a physical address. ALE is asserted during a T_a cycle and deasserted before the beginning of the T_d state. It is active HIGH and floats to a high impedance state during a hold cycle (T_h).															
ALE#	O R(1) H(Z) P(1)	ADDRESS LATCH ENABLE indicates the transfer of a physical address. ALE# is the inverted version of ALE. This signal gives the 80960Jx a high degree of compatibility with existing 80960Kx systems.															
ADS#	O R(1) H(Z) P(1)	ADDRESS STROBE indicates a valid address and the start of a new bus access. The processor asserts ADS# for the entire T_a cycle. External bus control logic typically samples ADS# at the end of the cycle.															
A[3:2]	O R(X) H(Z) P(Q)	<p>ADDRESS[3:2] comprise a partial demultiplexed address bus.</p> <p><i>32-bit memory accesses:</i> the processor asserts address bits A[3:2] during T_a. The partial word address increments with each assertion of RDYRCV# during a burst.</p> <p><i>16-bit memory accesses:</i> the processor asserts address bits A[3:1] during T_a with A1 driven on the BE1# pin. The partial short word address increments with each assertion of RDYRCV# during a burst.</p> <p><i>8-bit memory accesses:</i> the processor asserts address bits A[3:0] during T_a, with A[1:0] driven on BE[1:0]#. The partial byte address increments with each assertion of RDYRCV# during a burst.</p>															

Table 3. Pin Description — External Bus Signals (Sheet 2 of 4)

NAME	TYPE	DESCRIPTION												
BE[3:0]#	<p>○</p> <p>R(1) H(Z) P(1)</p>	<p>BYTE ENABLES select which of up to four data bytes on the bus participate in the current bus access. Byte enable encoding is dependent on the bus width of the memory region accessed:</p> <p><i>32-bit bus:</i> BE3# enables data on AD[31:24] BE2# enables data on AD[23:16] BE1# enables data on AD[15:8] BE0# enables data on AD[7:0]</p> <p><i>16-bit bus:</i> BE3# becomes Byte High Enable (enables data on AD[15:8]) BE2# is not used (state is high) BE1# becomes Address Bit 1 (A1) BE0# becomes Byte Low Enable (enables data on AD[7:0])</p> <p><i>8-bit bus:</i> BE3# is not used (state is high) BE2# is not used (state is high) BE1# becomes Address Bit 1 (A1) BE0# becomes Address Bit 0 (A0)</p> <p>The processor asserts byte enables, byte high enable and byte low enable during T_a. Since unaligned bus requests are split into separate bus transactions, these signals do not toggle during a burst. They remain active through the last T_d cycle.</p> <p>For accesses to 8- and 16-bit memory, the processor asserts the address bits in conjunction with A[3:2] described above.</p>												
WIDTH/ HLTD[1:0]	<p>○</p> <p>R(0) H(Z) P(1)</p>	<p>WIDTH/HALTED signals denote the physical memory attributes for a bus transaction:</p> <p>WIDTH/HLTD1WIDTH/HLTD0</p> <table border="0"> <tr> <td>0</td> <td>0</td> <td>8 Bits Wide</td> </tr> <tr> <td>0</td> <td>1</td> <td>16 Bits Wide</td> </tr> <tr> <td>1</td> <td>0</td> <td>32 Bits Wide</td> </tr> <tr> <td>1</td> <td>1</td> <td>Processor Halted</td> </tr> </table> <p>The processor floats the WIDTH/HLTD pins whenever it relinquishes the bus in response to a HOLD request, regardless of prior operating state.</p>	0	0	8 Bits Wide	0	1	16 Bits Wide	1	0	32 Bits Wide	1	1	Processor Halted
0	0	8 Bits Wide												
0	1	16 Bits Wide												
1	0	32 Bits Wide												
1	1	Processor Halted												
D/C#	<p>○</p> <p>R(X) H(Z) P(Q)</p>	<p>DATA/CODE indicates that a bus access is a data access (1) or an instruction access (0). D/C# has the same timing as W/R#.</p> <p>0 = instruction access 1 = data access</p>												
W/R#	<p>○</p> <p>R(0) H(Z) P(Q)</p>	<p>WRITE/READ specifies, during a T_a cycle, whether the operation is a write (1) or read (0). It is latched on-chip and remains valid during T_d cycles.</p> <p>0 = read 1 = write</p>												
DT/R#	<p>○</p> <p>R(0) H(Z) P(Q)</p>	<p>DATA TRANSMIT / RECEIVE indicates the direction of data transfer to and from the address/data bus. It is low during T_a and T_w/T_d cycles for a read; it is high during T_a and T_w/T_d cycles for a write. DT/R# never changes state when DEN# is asserted.</p> <p>0 = receive 1 = transmit</p>												

Table 3. Pin Description — External Bus Signals (Sheet 3 of 4)

NAME	TYPE	DESCRIPTION
DEN#	O R(1) H(Z) P(1)	<p>DATA ENABLE indicates data transfer cycles during a bus access. DEN# is asserted at the start of the first data cycle in a bus access and deasserted at the end of the last data cycle. DEN# is used with DT/R# to provide control for data transceivers connected to the data bus.</p> <p>0 = data cycle 1 = not data cycle</p>
BLAST#	O R(1) H(Z) P(1)	<p>BURST LAST indicates the last transfer in a bus access. BLAST# is asserted in the last data transfer of burst and non-burst accesses. BLAST# remains active as long as wait states are inserted via the RDYRCV# pin. BLAST# becomes inactive after the final data transfer in a bus cycle.</p> <p>0 = last data transfer 1 = not last data transfer</p>
RDYRCV#	I S(L)	<p>READY/RECOVER indicates that data on AD lines can be sampled or removed. If RDYRCV# is not asserted during a T_d cycle, the T_d cycle is extended to the next cycle by inserting a wait state (T_w).</p> <p>0 = sample data 1 = don't sample data</p> <p>The RDYRCV# pin has another function during the recovery (T_r) state. The processor continues to insert additional recovery states until it samples the pin HIGH. This function gives slow external devices more time to float their buffers before the processor begins to drive address again.</p> <p>0 = insert wait states 1 = recovery complete</p>
LOCK#/ ONCE#	I/O S(L) R(H) H(Z) P(1)	<p>BUS LOCK indicates that an atomic read-modify-write operation is in progress. The LOCK# output is asserted in the first clock of an atomic operation and deasserted in the last data transfer of the sequence. The processor does not grant HOLDA while it is asserting LOCK#. This prevents external agents from accessing memory involved in semaphore operations.</p> <p>0 = Atomic read-modify-write in progress 1 = Atomic read-modify-write not in progress</p> <p>ONCE MODE: The processor samples the ONCE# input during reset. If it is asserted LOW at the end of reset, the processor enters ONCE mode. In ONCE mode, the processor stops all clocks and floats all output pins. The pin has a weak internal pullup which is active during reset to ensure normal operation when the pin is left unconnected.</p> <p>0 = ONCE mode enabled 1 = ONCE mode not enabled</p>
HOLD	I S(L)	<p>HOLD: A request from an external bus master to acquire the bus. When the processor receives HOLD and grants bus control to another master, it asserts HOLDA, floats the address/data and control lines and enters the T_h state. When HOLD is deasserted, the processor deasserts HOLDA and enters either the T_i or T_a state, resuming control of the address/data and control lines.</p> <p>0 = no hold request 1 = hold request</p>
HOLDA	O R(Q) H(1) P(Q)	<p>HOLD ACKNOWLEDGE indicates to an external bus master that the processor has relinquished control of the bus. The processor can grant HOLD requests and enter the T_h state during reset and while halted as well as during regular operation.</p> <p>0 = hold not acknowledged 1 = hold acknowledged</p>

Table 3. Pin Description — External Bus Signals (Sheet 4 of 4)

NAME	TYPE	DESCRIPTION
BSTAT	<p>O</p> <p>R(0)</p> <p>H(Q)</p> <p>P(0)</p>	<p>BUS STATUS indicates that the processor may soon stall unless it has sufficient access to the bus; see <i>i960[®] Jx Microprocessor User's Guide (272483)</i>. Arbitration logic can examine this signal to determine when an external bus master should acquire/relinquish the bus.</p> <p>0 = no potential stall 1 = potential stall</p>

Table 4. Pin Description — Processor Control Signals, Test Signals and Power (Sheet 1 of 2)

NAME	TYPE	DESCRIPTION
CLKIN	I	CLOCK INPUT provides the processor's fundamental time base; both the processor core and the external bus run at the CLKIN rate. All input and output timings are specified relative to a rising CLKIN edge.
RESET#	<p>I</p> <p>A(L)</p>	<p>RESET initializes the processor and clears its internal logic. During reset, the processor places the address/data bus and control output pins in their idle (inactive) states.</p> <p>During reset, the input pins are ignored with the exception of LOCK#/ONCE#, STEST and HOLD.</p> <p>The RESET# pin has an internal synchronizer. To ensure predictable processor initialization during power up, RESET# must be asserted a minimum of 10,000 CLKIN cycles with V_{CC} and CLKIN stable. On a warm reset, RESET# should be asserted for a minimum of 15 cycles.</p>
STEST	<p>I</p> <p>S(L)</p>	<p>SELF TEST enables or disables the processor's internal self-test feature at initialization. STEST is examined at the end of reset. When STEST is asserted, the processor performs its internal self-test and the external bus confidence test. When STEST is deasserted, the processor performs only the external bus confidence test.</p> <p>0 = self test disabled 1 = self test enabled</p>
FAIL#	<p>O</p> <p>R(0)</p> <p>H(Q)</p> <p>P(1)</p>	<p>FAIL indicates a failure of the processor's built-in self-test performed during initialization. FAIL# is asserted immediately upon reset and toggles during self-test to indicate the status of individual tests:</p> <ul style="list-style-type: none"> When self-test passes, the processor deasserts FAIL# and begins operation from user code. When self-test fails, the processor asserts FAIL# and then stops executing. <p>0 = self test failed 1 = self test passed</p>
TCK	I	TEST CLOCK is a CPU input which provides the clocking function for IEEE 1149.1 Boundary Scan Testing (JTAG). State information and data are clocked into the processor on the rising edge; data is clocked out of the processor on the falling edge.
TDI	<p>I</p> <p>S(L)</p>	TEST DATA INPUT is the serial input pin for JTAG. TDI is sampled on the rising edge of TCK, during the SHIFT-IR and SHIFT-DR states of the Test Access Port.
TDO	<p>O</p> <p>R(Q)</p> <p>H(Q)</p> <p>P(Q)</p>	TEST DATA OUTPUT is the serial output pin for JTAG. TDO is driven on the falling edge of TCK during the SHIFT-IR and SHIFT-DR states of the Test Access Port. At other times, TDO floats. TDO does not float during ONCE mode.
TRST#	<p>I</p> <p>A(L)</p>	TEST RESET asynchronously resets the Test Access Port (TAP) controller function of IEEE 1149.1 Boundary Scan testing (JTAG). When using the Boundary Scan feature, connect a pull-down resistor between this pin and V_{SS} . If TAP is not used, this pin must be connected to V_{SS} ; however, no resistor is required. See Section 4.3, "Connection Recommendations" on page 40.

Table 4. Pin Description — Processor Control Signals, Test Signals and Power (Sheet 2 of 2)

NAME	TYPE	DESCRIPTION
TMS	I S(L)	TEST MODE SELECT is sampled at the rising edge of TCK to select the operation of the test logic for IEEE 1149.1 Boundary Scan testing.
V _{CC}	–	POWER pins intended for external connection to a V _{CC} board plane.
VCCPLL	–	PLL POWER is a separate V _{CC} supply pin for the phase lock loop clock generator. It is intended for external connection to the V _{CC} board plane. In noisy environments, add a simple bypass filter circuit to reduce noise-induced clock jitter and its effects on timing relationships.
VCC5	–	5 V REFERENCE VOLTAGE input is the reference voltage for the 5 V-tolerant I/O buffers. This signal should be connected to +5 V for use with inputs which exceed 3.3 V. If all inputs are from 3.3 V components, this pin should be connected to 3.3 V.
V _{SS}	–	GROUND pins intended for external connection to a V _{SS} board plane.
NC	–	NO CONNECT pins. Do not make any system connections to these pins.

Table 5. Pin Description — Interrupt Unit Signals

NAME	TYPE	DESCRIPTION
XINT[7:0]#	I A(E/L)	<p>EXTERNAL INTERRUPT pins are used to request interrupt service. The XINT[7:0]# pins can be configured in three modes:</p> <p>Dedicated Mode: Each pin is assigned a dedicated interrupt level. Dedicated inputs can be programmed to be level (low) or edge (falling) sensitive.</p> <p>Expanded Mode: All eight pins act as a vectored interrupt source. The interrupt pins are level sensitive in this mode.</p> <p>Mixed Mode: The XINT[7:5]# pins act as dedicated sources and the XINT[4:0]# pins act as the five most significant bits of a vectored source. The least significant bits of the vectored source are set to 010₂ internally.</p> <p>Unused external interrupt pins should be connected to V_{CC}.</p>
NMI#	I A(E)	<p>NON-MASKABLE INTERRUPT causes a non-maskable interrupt event to occur. NMI# is the highest priority interrupt source and is falling edge-triggered. If NMI# is unused, it should be connected to V_{CC}.</p>

3.1.2 80960Jx 132-Lead PGA Pinout

Figure 3. 132-Lead Pin Grid Array Top View - Pins Facing Down

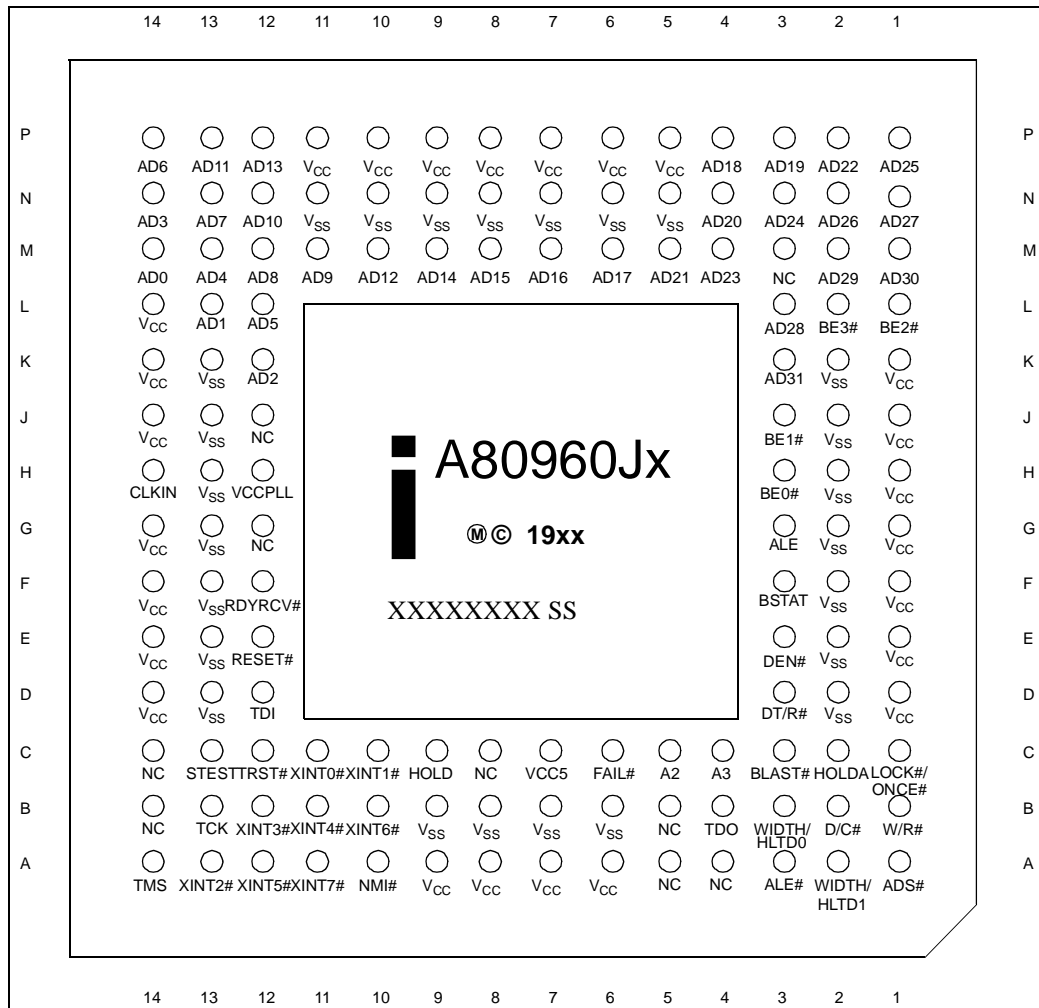

Figure 4. 132-Lead Pin Grid Array Bottom View - Pins Facing Up

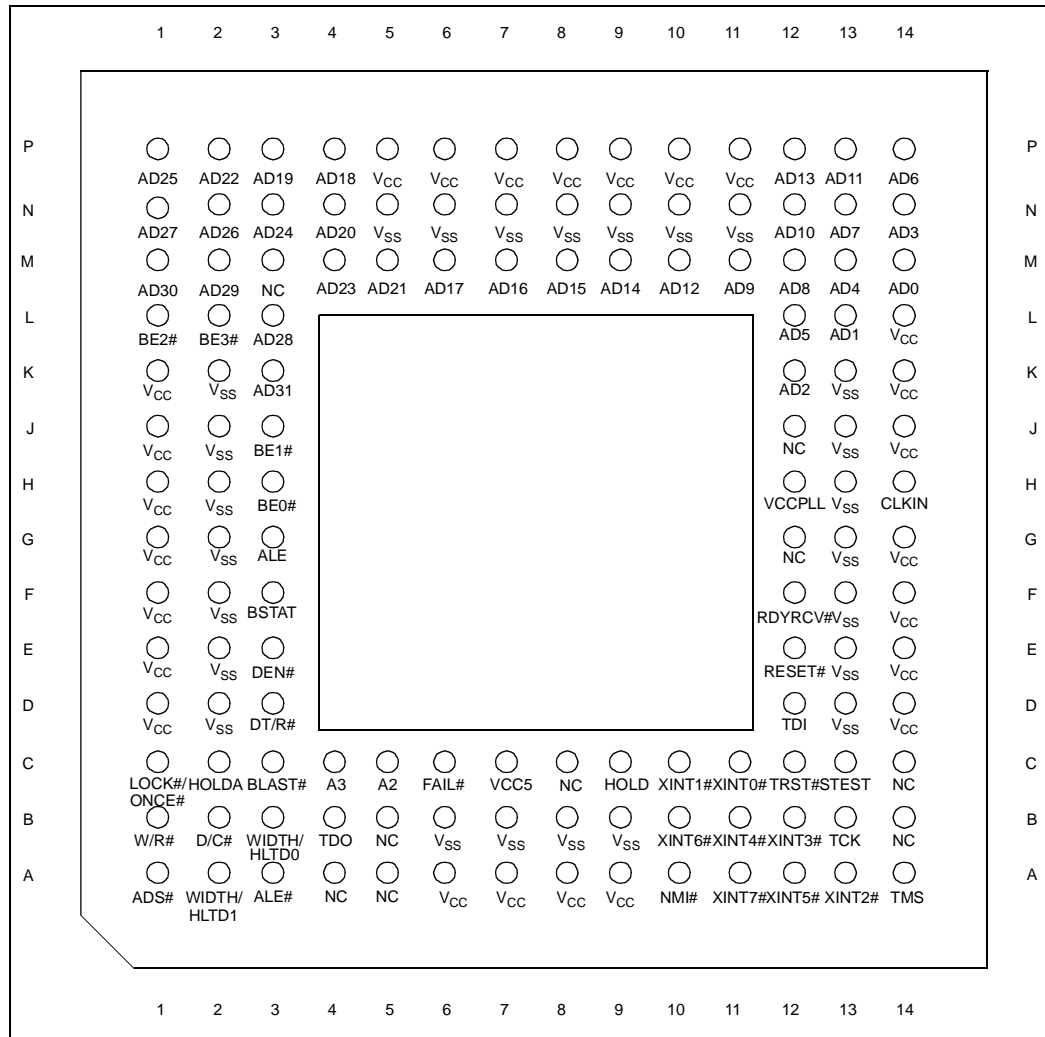

Table 6. 132-Lead PGA Pinout — In Signal Order

Signal	Pin	Signal	Pin	Signal	Pin	Signal	Pin
A2	C5	AD31	K3	TDO	B4	V _{SS}	B9
A3	C4	ADS#	A1	TMS	A14	V _{SS}	D2
AD0	M14	ALE	G3	TRST#	C12	V _{SS}	D13
AD1	L13	ALE#	A3	V _{CC}	A6	V _{SS}	E2
AD2	K12	BE0#	H3	V _{CC}	A7	V _{SS}	E13
AD3	N14	BE1#	J3	V _{CC}	A8	V _{SS}	F2
AD4	M13	BE2#	L1	V _{CC}	A9	V _{SS}	F13
AD5	L12	BE3#	L2	V _{CC}	D1	V _{SS}	G2
AD6	P14	BLAST#	C3	V _{CC}	D14	V _{SS}	G13
AD7	N13	BSTAT	F3	V _{CC}	E1	V _{SS}	H2
AD8	M12	CLKIN	H14	V _{CC}	E14	V _{SS}	H13
AD9	M11	D/C#	B2	V _{CC}	F1	V _{SS}	J2
AD10	N12	DEN#	E3	V _{CC}	F14	V _{SS}	J13
AD11	P13	DT/R#	D3	V _{CC}	G1	V _{SS}	K2
AD12	M10	FAIL#	C6	V _{CC}	G14	V _{SS}	K13
AD13	P12	HOLD	C9	V _{CC}	H1	V _{SS}	N5
AD14	M9	HOLDA	C2	V _{CC}	J1	V _{SS}	N6
AD15	M8	LOCK#/ONCE#	C1	V _{CC}	J14	V _{SS}	N7
AD16	M7	NC	A4	V _{CC}	K1	V _{SS}	N8
AD17	M6	NC	A5	V _{CC}	K14	V _{SS}	N9
AD18	P4	NC	B5	V _{CC}	L14	V _{SS}	N10
AD19	P3	NC	B14	V _{CC}	P5	V _{SS}	N11
AD20	N4	NC	C8	V _{CC}	P6	W/R#	B1
AD21	M5	NC	C14	V _{CC}	P7	WIDTH/HLTD0	B3
AD22	P2	NC	G12	V _{CC}	P8	WIDTH/HLTD1	A2
AD23	M4	NC	J12	V _{CC}	P9	XINT0#	C11
AD24	N3	NC	M3	V _{CC}	P10	XINT1#	C10
AD25	P1	NMI#	A10	V _{CC}	P11	XINT2#	A13
AD26	N2	RDYRCV#	F12	VCCPLL	H12	XINT3#	B12
AD27	N1	RESET#	E12	VCC5	C7	XINT4#	B11
AD28	L3	STEST	C13	V _{SS}	B6	XINT5#	A12
AD29	M2	TCK	B13	V _{SS}	B7	XINT6#	B10
AD30	M1	TDI	D12	V _{SS}	B8	XINT7#	A11

NOTE: Do not connect any external logic to pins marked NC (no connect pins).

Table 7. 132-Lead PGA Pinout — In Pin Order

Pin	Signal	Pin	Signal	Pin	Signal	Pin	Signal
A1	ADS#	C6	FAIL#	H1	V _{CC}	M10	AD12
A2	WIDTH/HLTD1	C7	VCC5	H2	V _{SS}	M11	AD9
A3	ALE#	C8	NC	H3	BE0#	M12	AD8
A4	NC	C9	HOLD	H12	VCCPLL	M13	AD4
A5	NC	C10	XINT1#	H13	V _{SS}	M14	AD0
A6	V _{CC}	C11	XINT0#	H14	CLKIN	N1	AD27
A7	V _{CC}	C12	TRST#	J1	V _{CC}	N2	AD26
A8	V _{CC}	C13	STEST	J2	V _{SS}	N3	AD24
A9	V _{CC}	C14	NC	J3	BE1#	N4	AD20
A10	NMI#	D1	V _{CC}	J12	NC	N5	V _{SS}
A11	XINT7#	D2	V _{SS}	J13	V _{SS}	N6	V _{SS}
A12	XINT5#	D3	DT/R#	J14	V _{CC}	N7	V _{SS}
A13	XINT2#	D12	TDI	K1	V _{CC}	N8	V _{SS}
A14	TMS	D13	V _{SS}	K2	V _{SS}	N9	V _{SS}
B1	W/R#	D14	V _{CC}	K3	AD31	N10	V _{SS}
B2	D/C#	E1	V _{CC}	K12	AD2	N11	V _{SS}
B3	WIDTH/HLTD0	E2	V _{SS}	K13	V _{SS}	N12	AD10
B4	TDO	E3	DEN#	K14	V _{CC}	N13	AD7
B5	NC	E12	RESET#	L1	BE2#	N14	AD3
B6	V _{SS}	E13	V _{SS}	L2	BE3#	P1	AD25
B7	V _{SS}	E14	V _{CC}	L3	AD28	P2	AD22
B8	V _{SS}	F1	V _{CC}	L12	AD5	P3	AD19
B9	V _{SS}	F2	V _{SS}	L13	AD1	P4	AD18
B10	XINT6#	F3	BSTAT	L14	V _{CC}	P5	V _{CC}
B11	XINT4#	F12	RDYRCV#	M1	AD30	P6	V _{CC}
B12	XINT3#	F13	V _{SS}	M2	AD29	P7	V _{CC}
B13	TCK	F14	V _{CC}	M3	NC	P8	V _{CC}
B14	NC	G1	V _{CC}	M4	AD23	P9	V _{CC}
C1	LOCK#/ONCE#	G2	V _{SS}	M5	AD21	P10	V _{CC}
C2	HOLDA	G3	ALE	M6	AD17	P11	V _{CC}
C3	BLAST#	G12	NC	M7	AD16	P12	AD13
C4	A3	G13	V _{SS}	M8	AD15	P13	AD11
C5	A2	G14	V _{CC}	M9	AD14	P14	AD6

NOTE: Do not connect any external logic to pins marked NC (no connect pins).

3.1.3 80960Jx 132-Lead PQFP Pinout

Figure 5. 132-Lead PQFP - Top View

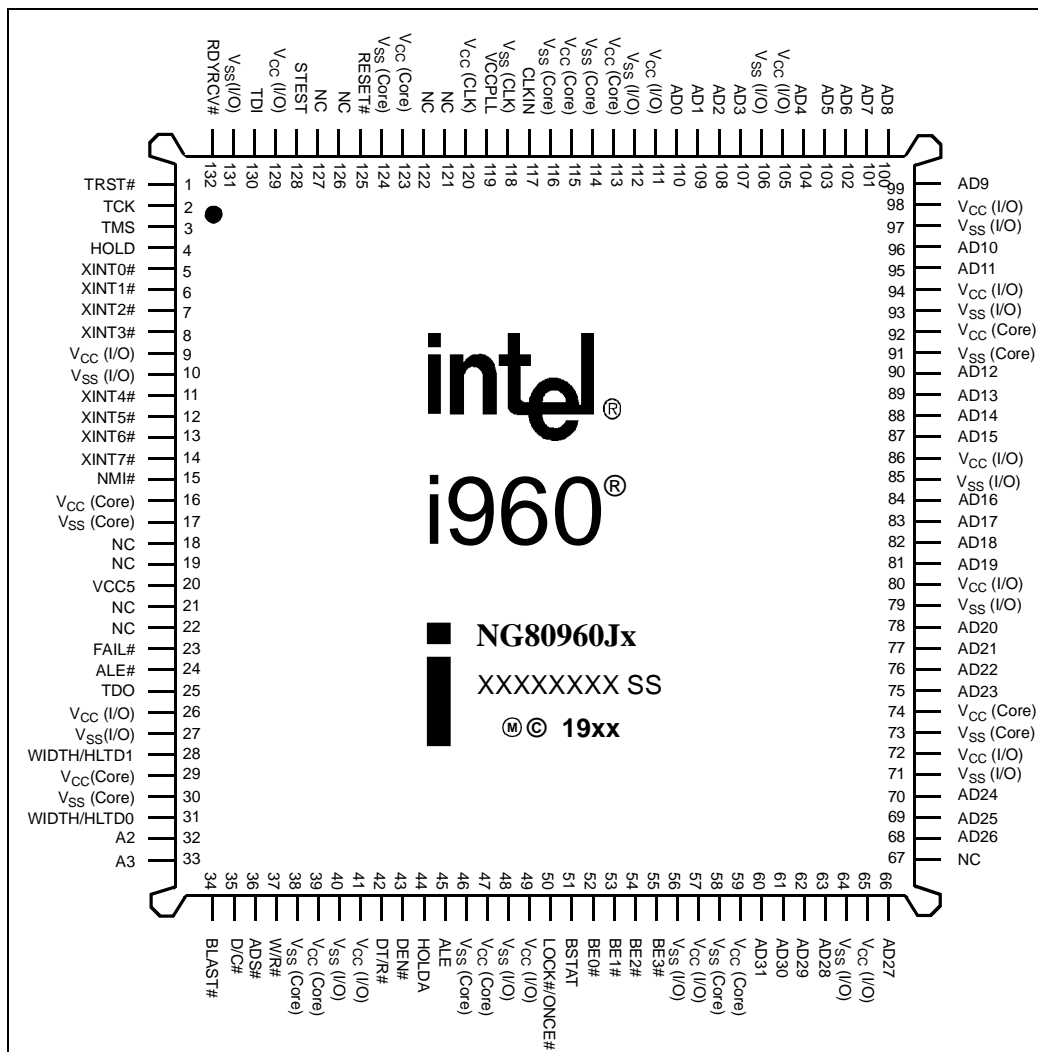

Table 8. 132-Lead PQFP Pinout — In Signal Order

Signal	Pin	Signal	Pin	Signal	Pin	Signal	Pin
AD31	60	ALE#	24	V _{CC} (Core)	47	V _{SS} (Core)	124
AD30	61	ADS#	36	V _{CC} (Core)	59	V _{SS} (I/O)	10
AD29	62	A3	33	V _{CC} (Core)	74	V _{SS} (I/O)	27
AD28	63	A2	32	V _{CC} (Core)	92	V _{SS} (I/O)	40
AD27	66	BE3#	55	V _{CC} (Core)	113	V _{SS} (I/O)	48
AD26	68	BE2#	54	V _{CC} (Core)	115	V _{SS} (I/O)	56
AD25	69	BE1#	53	V _{CC} (Core)	123	V _{SS} (I/O)	64
AD24	70	BE0#	52	V _{CC} (I/O)	9	V _{SS} (I/O)	71
AD23	75	WIDTH/HLTD1	28	V _{CC} (I/O)	26	V _{SS} (I/O)	79
AD22	76	WIDTH/HLTD0	31	V _{CC} (I/O)	41	V _{SS} (I/O)	85
AD21	77	D/C#	35	V _{CC} (I/O)	49	V _{SS} (I/O)	93
AD20	78	W/R#	37	V _{CC} (I/O)	57	V _{SS} (I/O)	97
AD19	81	DT/R#	42	V _{CC} (I/O)	65	V _{SS} (I/O)	106
AD18	82	DEN#	43	V _{CC} (I/O)	72	V _{SS} (I/O)	112
AD17	83	BLAST#	34	V _{CC} (I/O)	80	V _{SS} (I/O)	131
AD16	84	RDYRCV#	132	V _{CC} (I/O)	86	NC	18
AD15	87	LOCK#/ONCE#	50	V _{CC} (I/O)	94	NC	19
AD14	88	HOLD	4	V _{CC} (I/O)	98	NC	21
AD13	89	HOLDA	44	V _{CC} (I/O)	105	NC	22
AD12	90	BSTAT	51	V _{CC} (I/O)	111	NC	67
AD11	95	CLKIN	117	V _{CC} (I/O)	129	NC	121
AD10	96	RESET#	125	V _{CC} PLL	119	NC	122
AD9	99	STEST	128	V _{CC} 5	20	NC	126
AD8	100	FAIL#	23	V _{SS} (CLK)	118	NC	127
AD7	101	TCK	2	V _{SS} (Core)	17	XINT7#	14
AD6	102	TDI	130	V _{SS} (Core)	30	XINT6#	13
AD5	103	TDO	25	V _{SS} (Core)	38	XINT5#	12
AD4	104	TRST#	1	V _{SS} (Core)	46	XINT4#	11
AD3	107	TMS	3	V _{SS} (Core)	58	XINT3#	8
AD2	108	V _{CC} (CLK)	120	V _{SS} (Core)	73	XINT2#	7
AD1	109	V _{CC} (Core)	16	V _{SS} (Core)	91	XINT1#	6
AD0	110	V _{CC} (Core)	29	V _{SS} (Core)	114	XINT0#	5
ALE	45	V _{CC} (Core)	39	V _{SS} (Core)	116	NMI#	15

NOTE: Do not connect any external logic to pins marked NC (no connect pins).

Table 9. 132-Lead PQFP Pinout — In Pin Order

Pin	Signal	Pin	Signal	Pin	Signal	Pin	Signal
1	TRST#	34	BLAST#	67	NC	100	AD8
2	TCK	35	D/C#	68	AD26	101	AD7
3	TMS	36	ADS#	69	AD25	102	AD6
4	HOLD	37	W/R#	70	AD24	103	AD5
5	XINT0#	38	V _{SS} (Core)	71	V _{SS} (I/O)	104	AD4
6	XINT1#	39	V _{CC} (Core)	72	V _{CC} (I/O)	105	V _{CC} (I/O)
7	XINT2#	40	V _{SS} (I/O)	73	V _{SS} (Core)	106	V _{SS} (I/O)
8	XINT3#	41	V _{CC} (I/O)	74	V _{CC} (Core)	107	AD3
9	V _{CC} (I/O)	42	DT/R#	75	AD23	108	AD2
10	V _{SS} (I/O)	43	DEN#	76	AD22	109	AD1
11	XINT4#	44	HOLDA	77	AD21	110	AD0
12	XINT5#	45	ALE	78	AD20	111	V _{CC} (I/O)
13	XINT6#	46	V _{SS} (Core)	79	V _{SS} (I/O)	112	V _{SS} (I/O)
14	XINT7#	47	V _{CC} (Core)	80	V _{CC} (I/O)	113	V _{CC} (Core)
15	NMI#	48	V _{SS} (I/O)	81	AD19	114	V _{SS} (Core)
16	V _{CC} (Core)	49	V _{CC} (I/O)	82	AD18	115	V _{CC} (Core)
17	V _{SS} (Core)	50	LOCK#/ONCE#	83	AD17	116	V _{SS} (Core)
18	NC	51	BSTAT	84	AD16	117	CLKIN
19	NC	52	BE0#	85	V _{SS} (I/O)	118	V _{SS} (CLK)
20	VCC5	53	BE1#	86	V _{CC} (I/O)	119	VCCPLL
21	NC	54	BE2#	87	AD15	120	V _{CC} (CLK)
22	NC	55	BE3#	88	AD14	121	NC
23	FAIL#	56	V _{SS} (I/O)	89	AD13	122	NC
24	ALE#	57	V _{CC} (I/O)	90	AD12	123	V _{CC} (Core)
25	TDO	58	V _{SS} (Core)	91	V _{SS} (Core)	124	V _{SS} (Core)
26	V _{CC} (I/O)	59	V _{CC} (Core)	92	V _{CC} (Core)	125	RESET#
27	V _{SS} (I/O)	60	AD31	93	V _{SS} (I/O)	126	NC
28	WIDTH/HLTD1	61	AD30	94	V _{CC} (I/O)	127	NC
29	V _{CC} (Core)	62	AD29	95	AD11	128	STEST
30	V _{SS} (Core)	63	AD28	96	AD10	129	V _{CC} (I/O)
31	WIDTH/HLTD0	64	V _{SS} (I/O)	97	V _{SS} (I/O)	130	TDI
32	A2	65	V _{CC} (I/O)	98	V _{CC} (I/O)	131	V _{SS} (I/O)
33	A3	66	AD27	99	AD9	132	RDYRCV#

NOTE: Do not connect any external logic to pins marked NC (no connect pins).

3.1.4 80960Jx 196-Ball MPBGA Pinout

Figure 6. 196-Ball Mini Plastic Ball Grid Array Top View - Balls Facing Down

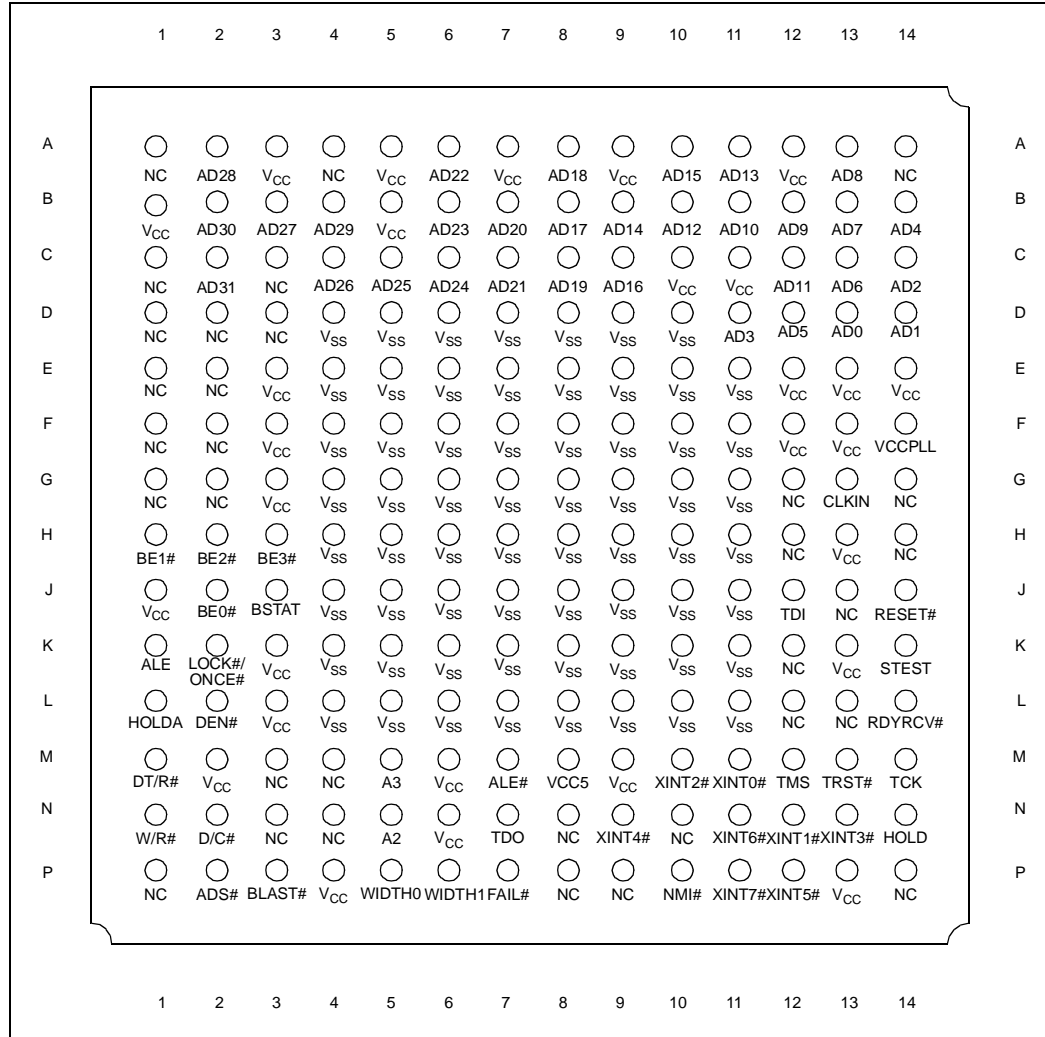

Figure 7. 196-Ball Mini Plastic Ball Grid Array Bottom View - Balls Facing Up

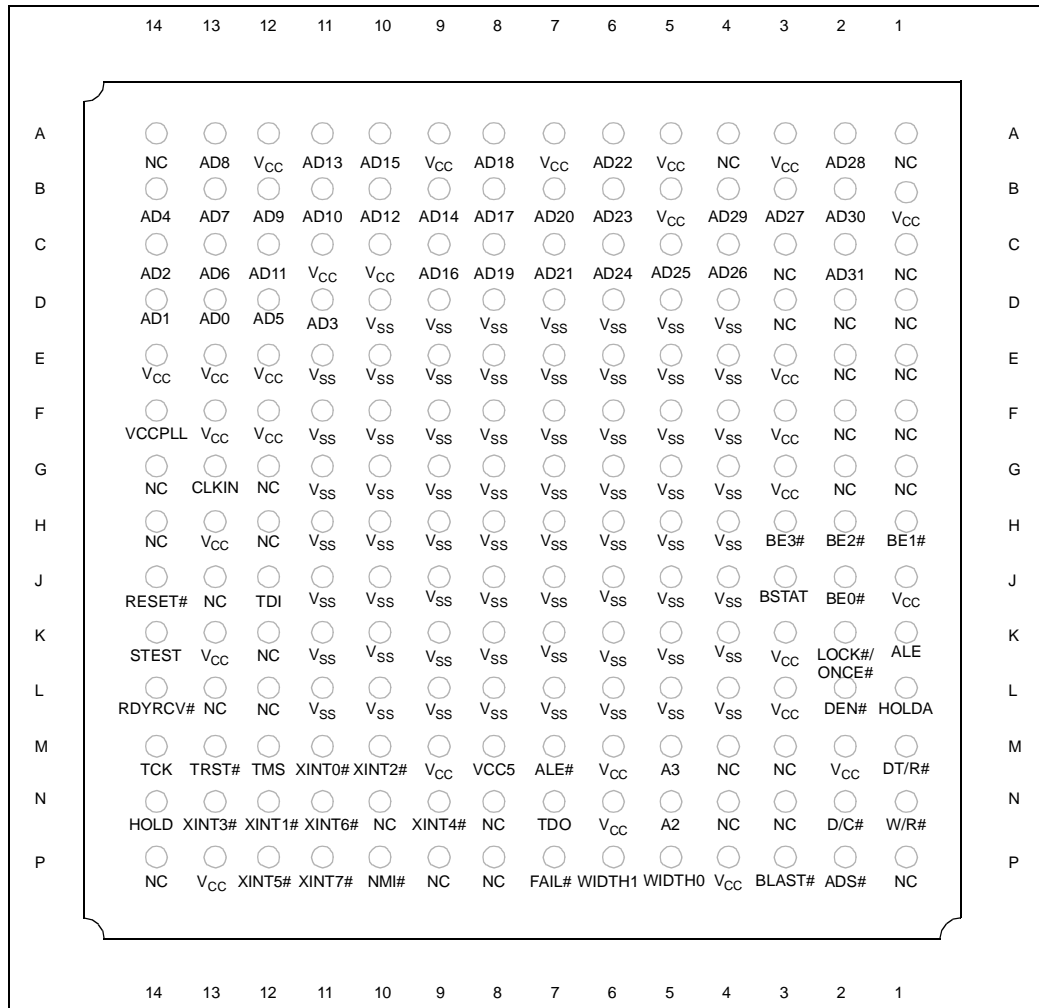

Table 10. 196-Ball MPBGA Pinout — In Signal Order (Sheet 1 of 2)

Signal	Pin	Signal	Pin	Signal	Pin	Signal	Pin
A2	N5	BE0#	J2	NC	M4	V _{CC}	J1
A3	M5	BE1#	H1	NC	N3	V _{CC}	K3
AD0	D13	BE2#	H2	NC	N4	V _{CC}	K13
AD1	D14	BE3#	H3	NC	N8	V _{CC}	L3
AD2	C14	BLAST#	P3	NC	N10	V _{CC}	M2
AD3	D11	BSTAT	J3	NC	P1	V _{CC}	M6
AD4	B14	CLKIN	G13	NC	P8	V _{CC}	M9
AD5	D12	DEN#	L2	NC	P9	V _{CC}	N6
AD6	C13	D/C#	N2	NC	P14	V _{CC}	P4
AD7	B13	DT/R#	M1	NMI#	P10	V _{CC}	P13
AD8	A13	FAIL#	P7	RDYRCV#	L14	V _{CC} PLL	F14
AD9	B12	HOLD	N14	RESET#	J14	V _{SS}	D4
AD10	B11	HOLDA	L1	STEST	K14	V _{SS}	D5
AD11	C12	LOCK#/ONCE#	K2	TCK	M14	V _{SS}	D6
AD12	B10	NC	A1	TDI	J12	V _{SS}	D7
AD13	A11	NC	A4	TDO	N7	V _{SS}	D8
AD14	B9	NC	A14	TMS	M12	V _{SS}	D9
AD15	A10	NC	C1	TRST#	M13	V _{SS}	D10
AD16	C9	NC	C3	V _{CC} 5	M8	V _{SS}	E4
AD17	B8	NC	D1	V _{CC}	A3	V _{SS}	E5
AD18	A8	NC	D2	V _{CC}	A5	V _{SS}	E6
AD19	C8	NC	D3	V _{CC}	A7	V _{SS}	E7
AD20	B7	NC	E1	V _{CC}	A9	V _{SS}	E8
AD21	C7	NC	E2	V _{CC}	A12	V _{SS}	E9
AD22	A6	NC	F1	V _{CC}	B1	V _{SS}	E10
AD23	B6	NC	F2	V _{CC}	B5	V _{SS}	E11
AD24	C6	NC	G1	V _{CC}	C10	V _{SS}	F4
AD25	C5	NC	G2	V _{CC}	C11	V _{SS}	F5
AD26	C4	NC	G12	V _{CC}	E3	V _{SS}	F6
AD27	B3	NC	G14	V _{CC}	E12	V _{SS}	F7
AD28	A2	NC	H12	V _{CC}	E13	V _{SS}	F8
AD29	B4	NC	H14	V _{CC}	E14	V _{SS}	F9
AD30	B2	NC	J13	V _{CC}	F3	V _{SS}	F10
AD31	C2	NC	K12	V _{CC}	F12	V _{SS}	F11
ADS#	P2	NC	L12	V _{CC}	F13	V _{SS}	G4
ALE	K1	NC	L13	V _{CC}	G3	V _{SS}	G5

NOTE: Do not connect any external logic to pins marked NC (no connect pins).

Table 10. 196-Ball MPBGA Pinout — In Signal Order (Sheet 2 of 2)

Signal	Pin	Signal	Pin	Signal	Pin	Signal	Pin
ALE#	M7	NC	M3	V _{CC}	H13	V _{SS}	G6
V _{SS}	G7	V _{SS}	H11	V _{SS}	K7	V _{SS}	L11
V _{SS}	G8	V _{SS}	J4	V _{SS}	K8	WIDTH0	P5
V _{SS}	G9	V _{SS}	J5	V _{SS}	K9	WIDTH1	P6
V _{SS}	G10	V _{SS}	J6	V _{SS}	K10	W/R#	N1
V _{SS}	G11	V _{SS}	J7	V _{SS}	K11	XINT0#	M11
V _{SS}	H4	V _{SS}	J8	V _{SS}	L5	XINT1#	N12
V _{SS}	H5	V _{SS}	J9	V _{SS}	L6	XINT2#	M10
V _{SS}	H6	V _{SS}	J10	V _{SS}	L7	XINT3#	N13
V _{SS}	H7	V _{SS}	J11	V _{SS}	L8	XINT4#	N9
V _{SS}	H8	V _{SS}	K4	V _{SS}	L9	XINT5#	P12
V _{SS}	H9	V _{SS}	K5	V _{SS}	L10	XINT6#	N11
V _{SS}	H10	V _{SS}	K6	V _{SS}	L4	XINT7#	P11

NOTE: Do not connect any external logic to pins marked NC (no connect pins).

Table 11. 196-Ball MPBGA Pinout — In Pin Order (Sheet 1 of 2)

Pin	Signal	Pin	Signal	Pin	Signal	Pin	Signal
A1	NC	C11	V _{CC}	F7	V _{SS}	J3	BSTAT
A2	AD28	C12	AD11	F8	V _{SS}	J4	V _{SS}
A3	V _{CC}	C13	AD6	F9	V _{SS}	J5	V _{SS}
A4	NC	C14	AD2	F10	V _{SS}	J6	V _{SS}
A5	V _{CC}	D1	NC	F11	V _{SS}	J7	V _{SS}
A6	AD22	D2	NC	F12	V _{CC}	J8	V _{SS}
A7	V _{CC}	D3	NC	F13	V _{CC}	J9	V _{SS}
A8	AD18	D4	V _{SS}	F14	VCCPLL	J10	V _{SS}
A9	V _{CC}	D5	V _{SS}	G1	NC	J11	V _{SS}
A10	AD15	D6	V _{SS}	G2	NC	J12	TDI
A11	AD13	D7	V _{SS}	G3	V _{CC}	J13	NC
A12	V _{CC}	D8	V _{SS}	G4	V _{SS}	J14	RESET#
A13	AD8	D9	V _{SS}	G5	V _{SS}	K1	ALE
A14	NC	D10	V _{SS}	G6	V _{SS}	K2	LOCK#/ONCE#
B1	V _{CC}	D11	AD3	G7	V _{SS}	K3	V _{CC}
B2	AD30	D12	AD5	G8	V _{SS}	K4	V _{SS}
B3	AD27	D13	AD0	G9	V _{SS}	K5	V _{SS}
B4	AD29	D14	AD1	G10	V _{SS}	K6	V _{SS}
B5	V _{CC}	E1	NC	G11	V _{SS}	K7	V _{SS}

NOTE: Do not connect any external logic to pins marked NC (no connect pins).

Table 11. 196-Ball MPBGA Pinout — In Pin Order (Sheet 2 of 2)

Pin	Signal	Pin	Signal	Pin	Signal	Pin	Signal
B6	AD23	E2	NC	G12	NC	K8	V _{SS}
B7	AD20	E3	V _{CC}	G13	CLKIN	K9	V _{SS}
B8	AD17	E4	V _{SS}	G14	NC	K10	V _{SS}
B9	AD14	E5	V _{SS}	H1	BE1#	K11	V _{SS}
B10	AD12	E6	V _{SS}	H2	BE2#	K12	NC
B11	AD10	E7	V _{SS}	H3	BE3#	K13	V _{CC}
B12	AD9	E8	V _{SS}	H4	V _{SS}	K14	STEST
B13	AD7	E9	V _{SS}	H5	V _{SS}	L1	HOLDA
B14	AD4	E10	V _{SS}	H6	V _{SS}	L2	DEN#
C1	NC	E11	V _{SS}	H7	V _{SS}	L3	V _{CC}
C2	AD31	E12	V _{CC}	H8	V _{SS}	L4	V _{SS}
C3	NC	E13	V _{CC}	H9	V _{SS}	L5	V _{SS}
C4	AD26	E14	V _{CC}	H10	V _{SS}	L6	V _{SS}
C5	AD25	F1	NC	H11	V _{SS}	L7	V _{SS}
C6	AD24	F2	NC	H12	NC	L8	V _{SS}
C7	AD21	F3	V _{CC}	H13	V _{CC}	L9	V _{SS}
C8	AD19	F4	V _{SS}	H14	NC	L10	V _{SS}
C9	AD16	F5	V _{SS}	J1	V _{CC}	L11	V _{SS}
C10	V _{CC}	F6	V _{SS}	J2	BE0#	L12	NC
L13	NC	M10	XINT2#	N7	TDO	P4	V _{CC}
L14	RDYRCV#	M11	XINT0#	N8	NC	P5	WIDTH0
M1	DT/R#	M12	TMS	N9	XINT4#	P6	WIDTH1
M2	V _{CC}	M13	TRST#	N10	NC#	P7	FAIL#
M3	NC	M14	TCK	N11	XINT6#	P8	NC
M4	NC	N1	W/R#	N12	XINT1#	P9	NC
M5	A3	N2	D/C#	N13	XINT3#	P10	NMI#
M6	V _{CC}	N3	NC	N14	HOLD	P11	XINT7#
M7	ALE#	N4	NC	P1	NC	P12	XINT5#
M8	VCC5	N5	A2	P2	ADS#	P13	V _{CC}
M9	V _{CC}	N6	V _{CC}	P3	BLAST#	P14	NC

NOTE: Do not connect any external logic to pins marked NC (no connect pins).

3.2 Package Thermal Specifications

The 80960Jx is specified for operation when T_C (case temperature) is within the range of 0°C to 100°C for PGA, MPBGA and PQFP packages. An extended temperature device is also available in a PQFP package with T_C -40°C to 100°C. Case temperature may be measured in any environment to determine whether the 80960Jx is within its specified operating range. The case temperature should be measured at the center of the top surface, opposite the pins.

θ_{CA} is the thermal resistance from case to ambient. Use the following equation to calculate T_A , the maximum ambient temperature to conform to a particular case temperature:

$$T_A = T_C - P (\theta_{CA})$$

Junction temperature (T_J) is commonly used in reliability calculations. T_J can be calculated from θ_{JC} (thermal resistance from junction to case) using the following equation:

$$T_J = T_C + P (\theta_{JC})$$

Similarly, if T_A is known, the corresponding case temperature (T_C) can be calculated as follows:

$$T_C = T_A + P (\theta_{CA})$$

Compute P by multiplying I_{CC} from Table 22, “80960Jx ICC Characteristics,” and V_{CC} . Values for θ_{JC} and θ_{CA} are given in Table 12 for the PGA package, Table 13 for the MPBGA package, and Table 14 for the PQFP package. For high speed operation, the processor’s θ_{JA} may be significantly reduced by adding a heatsink and/or by increasing airflow.

Tables 15, 16, and 17 show the maximum ambient temperature (T_A) permitted without exceeding T_C for the PGA, MPBGA, and PQFP packages. The values are based on typical I_{CC} and V_{CC} of +3.3 V, with a T_{CASE} of +100°C.

Table 12. 132-Lead PGA Package Thermal Characteristics

Thermal Resistance — °C/Watt						
Parameter	Airflow — ft./min (m/sec)					
	0 (0)	200 (1.01)	400 (2.03)	600 (3.04)	800 (4.06)	1000 (5.08)
θ_{JC} (Junction-to-Case)	0.7	0.7	0.7	0.7	0.7	0.7
θ_{CA} (Case-to-Ambient) (No Heatsink)	25	19	14	12	11	10
θ_{CA} (Case-to-Ambient) (Omnidirectional Heatsink)	15	9	6	5	4	4
θ_{CA} (Case-to-Ambient) (Unidirectional Heatsink)	16	8	6	5	4	4

NOTES:

1. This table applies to a PGA device plugged into a socket or soldered directly into a board.
2. $\theta_{JA} = \theta_{JC} + \theta_{CA}$
3. $\theta_{J-CAP} = 5.6^{\circ}\text{C/W}$ (approximate) (no heatsink)
4. $\theta_{J-PIN} = 6.4^{\circ}\text{C/W}$ (inner pins) (approximate) (no heatsink)
5. $\theta_{J-PIN} = 6.2^{\circ}\text{C/W}$ (outer pins) (approximate) (no heatsink)
6. $\theta_{J-CAP} = 3^{\circ}\text{C/W}$ (approximate) (with heatsink)
7. $\theta_{J-PIN} = 3.3^{\circ}\text{C/W}$ (inner pins) (approximate) (with heatsink)
8. $\theta_{J-PIN} = 3.3^{\circ}\text{C/W}$ (outer pins) (approximate) (with heatsink)

Table 13. 196-Ball MPBGA Package Thermal Characteristics

Thermal Resistance — °C/Watt						
Parameter	Airflow — ft./min (m/sec)					
	0 (0)	200 (1.01)	400 (2.03)	600 (3.04)	800 (4.06)	1000 (5.08)
θ_{JC} (Junction-to-Case)	TBD	TBD	TBD	TBD	TBD	TBD
θ_{CA} (Case-to-Ambient) (No Heatsink)	TBD	TBD	TBD	TBD	TBD	TBD
θ_{CA} (Case-to-Ambient) (Omnidirectional Heatsink)	TBD	TBD	TBD	TBD	TBD	TBD
θ_{CA} (Case-to-Ambient) (Unidirectional Heatsink)	TBD	TBD	TBD	TBD	TBD	TBD

TBD

Table 14. 132-Lead PQFP Package Thermal Characteristics

Thermal Resistance — °C/Watt							
Parameter	Airflow — ft./min (m/sec)						
	0 (0)	50 (0.25)	100 (0.50)	200 (1.01)	400 (2.03)	600 (3.04)	800 (4.06)
θ_{JC} (Junction-to-Case)	4.1	4.3	4.3	4.3	4.3	4.7	4.9
θ_{CA} (Case-to-Ambient -No Heatsink)	23	19	18	16	14	11	9

NOTES:

1. This table applies to a PQFP device soldered directly into board.
2. $\theta_{JA} = \theta_{JC} + \theta_{CA}$
3. $\theta_{JL} = 13^{\circ}\text{C/W}$ (approx.)
4. $\theta_{JB} = 13.5^{\circ}\text{C/W}$ (approx.)

Table 15. Maximum T_A at Various Airflows in °C (80960JT)

		f_{CLKIN} (MHz)	Airflow-ft/min (m/sec)					
			0 (0)	200 (1.01)	400 (2.03)	600 (3.04)	800 (4.06)	1000 (5.07)
PQFP Package	T_A without Heatsink	33	62	73	76	81	85	88
	T_A with Omnidirectional Heatsink ¹	33	75	85	90	92	93	93
PGA Package	T_A with Unidirectional Heatsink ²	33	73	86	90	92	93	93
MPBGA Package	T_A without Heatsink	33	TBD	TBD	TBD	TBD	TBD	TBD

NOTES:

1. 0.248" high omnidirectional heatsink (Al alloy 6061, 41 mil fin width, 124 mil center-to-center fin spacing).
2. 0.250" high unidirectional heatsink (Al alloy 6061, 50 mil fin width, 146 mil center-to-center fin spacing).

Table 16. Maximum T_A at Various Airflows in °C (80960JD)

		f_{CLKIN} (MHz)	Airflow-ft/min (m/sec)					
			0 (0)	200 (1.01)	400 (2.03)	600 (3.04)	800 (4.06)	1000 (5.07)
PQFP Package	T_A without Heatsink	33	61	73	76	81	85	86
		25	70	79	82	86	88	90
		20	75	82	85	88	90	91
		16.67	79	86	87	90	92	93
PGA Package	T_A without Heatsink	33	58	68	76	80	81	83
		25	68	75	82	84	86	87
		20	73	79	85	87	88	89
		16.67	78	83	87	89	90	91
	T_A with Omnidirectional Heatsink ¹	33	75	85	90	92	93	93
		25	81	88	92	94	95	95
		20	84	90	93	95	96	96
		16.67	87	92	95	96	96	96
	T_A with Unidirectional Heatsink ²	33	73	86	90	92	93	93
		25	79	90	92	94	95	96
		20	82	91	93	95	96	96
		16.67	86	93	95	96	96	96
MPBGA Package	T_A without Heatsink	25	TBD	TBD	TBD	TBD	TBD	TBD
		20	TBD	TBD	TBD	TBD	TBD	TBD
		16.67	TBD	TBD	TBD	TBD	TBD	TBD

NOTES:

- 0.248" high omnidirectional heatsink (Al alloy 6061, 41 mil fin width, 124 mil center-to-center fin spacing).
- 0.250" high unidirectional heatsink (Al alloy 6061, 50 mil fin width, 146 mil center-to-center fin spacing).

Table 17. Maximum T_A at Various Airflows in °C (80960JA/JF)

		f_{CLKIN} (MHz)	Airflow-ft/min (m/sec)					
			0 (0)	200 (1.01)	400 (2.03)	600 (3.04)	800 (4.06)	1000 (5.07)
PQFP Package	For NG80960JA/JF T_A without Heatsink	33	79	86	87	90	92	93
		25	84	89	90	92	94	94
		16	89	92	93	95	96	96
PGA Package	T_A without Heatsink	25	84	89	90	92	94	94
		33	78	83	87	89	90	91
		25	83	87	90	92	92	93
	T_A with Omnidirectional Heatsink ¹	16	88	91	93	94	95	95
		33	87	92	95	96	96	96
		25	90	94	96	97	97	97
	T_A with Unidirectional Heatsink ²	16	93	96	97	98	98	98
		33	86	93	95	96	96	96
		25	89	94	96	97	97	97
MPBGA Package	T_A without Heatsink	16	92	96	97	98	98	98
		33	TBD	TBD	TBD	TBD	TBD	TBD
		25	TBD	TBD	TBD	TBD	TBD	TBD
		16	TBD	TBD	TBD	TBD	TBD	

NOTES:

- 0.248" high omnidirectional heatsink (Al alloy 6061, 41 mil fin width, 124 mil center-to-center fin spacing).
- 0.250" high unidirectional heatsink (Al alloy 6061, 50 mil fin width, 146 mil center-to-center fin spacing).

3.3 Thermal Management Accessories

The following is a list of suggested sources for 80960Jx thermal solutions. This is neither an endorsement or a warranty of the performance of any of the listed products and/or companies.

3.3.1 Heatsinks

1. Thermalloy, Inc.
2021 West Valley View Lane
Dallas, TX 75234-8993
(972) 243-4321
2. Wakefield Engineering
60 Audubon Road
Wakefield, MA 01880
(617) 245-5900
3. Aavid Thermal Technologies, Inc.
One Kool Path
Laconia, NH 03247-0400
(603) 528-3400

4.0 Electrical Specifications: 80960Jx 3.3 V Processors

4.1 Absolute Maximum Ratings

This document contains information on products in the sampling and initial production phases of development. It is valid for the devices indicated in the revision history. The specifications within this data sheet are subject to change without notice. Verify with your local Intel sales office that you have the latest datasheet before finalizing a design.

Warning: Stressing the device beyond the “Absolute Maximum Ratings” may cause permanent damage. These are stress ratings only.

Table 18. Absolute Maximum Ratings

Parameter	Maximum Rating
Storage Temperature	-65°C to +150°C
Case Temperature Under Bias	-65°C to +110°C
Supply Voltage wrt. V_{SS}	-0.5 V to + 4.6 V
Voltage on VCC5 wrt. V_{SS}	-0.5 V to + 6.5 V
Voltage on Other Pins wrt. V_{SS}	-0.5 V to $V_{CC} + 0.5$ V

4.2 Operating Conditions

Warning: Operation beyond the “Operating Conditions” is not recommended and extended exposure beyond the “Operating Conditions” may affect device reliability.

Table 19 indicates the operating conditions for the 80960Jx.

Table 19. 80960Jx Operating Conditions

Symbol	Parameter	Min	Max	Units	Notes
V_{CC}	Supply Voltage	3.15	3.45	V	
VCC5	Input Protection Bias	3.15	5.5	V	(1)
f_{CLKIN}	Input Clock Frequency				
	80960JT-100	15	33.3	MHz	
	80960JD-66	12	33.3		
	80960JD-50	12	25		
	80960JD-40	12	20		
	80960JD-33	12	16.67		
	80960JA/JF-33	12	33.3		
	80960JA/JF-25	12	25		
80960JA/JF-16	12	16			
T_C	Operating Case Temperature			°C	
	PGA, MPBGA, and PQFP	0	100		
	Extended temp PQFP (TG80960JA-25)	-40	100		

NOTE:

- See Section 4.4, “VCC5 Pin Requirements (VDIFF)” on page 40.

4.3 Connection Recommendations

For clean on-chip power distribution, V_{CC} and V_{SS} pins separately feed the device's functional units. Power and ground connections must be made to all 80960Jx power and ground pins. On the circuit board, every V_{CC} pin should connect to a power plane and every V_{SS} pin should connect to a ground plane. Place liberal decoupling capacitance near the 80960Jx, since the processor can cause transient power surges.

Pay special attention to the Test Reset (TRST#) pin. It is essential that the JTAG Boundary Scan Test Access Port (TAP) controller initializes to a known state whether it will be used or not. If the JTAG Boundary Scan function will be used, connect a pull-down resistor between the TRST# pin and V_{SS} . If the JTAG Boundary Scan function will not be used (even for board-level testing), connect the TRST# pin to V_{SS} .

Do not connect the TDI, TDO, and TCK pins if the TAP Controller will not be used.

Note: Pins identified as NC must not be connected in the system.

4.4 VCC5 Pin Requirements (VDIFF)

In 3.3 V only systems where the 80960Jx input pins are driven from 3.3 V logic, connect the VCC5 pin directly to the 3.3 V V_{CC} plane.

In mixed voltage systems where the processor is powered by 3.3 V and interfaces with 5 V components, VCC5 must be connected to 5 V. This allows proper 5 V tolerant buffer operation, and prevents damage to the input pins. The voltage differential between the 80960Jx VCC5 pin and its 3.3 V V_{CC} pins must not exceed 2.25 V. If this requirement is not met, current flow through the pin may exceed the value at which the processor is damaged. Instances when the voltage can exceed 2.25 V is during power up or power down, where one source reaches its level faster than the other, briefly causing an excess voltage differential. Another instance is during steady-state operation, where the differential voltage of the regulator (provided a regulator is used) cannot be maintained within 2.25 V. Two methods are possible to prevent this from happening:

- Use a regulator that is designed to prevent the voltage differential from exceeding 2.25 V, or,
- As shown in Figure 8, place a 100 Ω resistor in series with the VCC5 pin to limit the current through VCC5.

Figure 8. VCC5 Current-Limiting Resistor

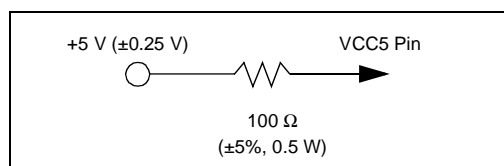

If the regulator cannot prevent the 2.25 V differential, the addition of the resistor is a simple and reliable method for limiting current. The resistor can also prevent damage in the case of a power failure, where the 5 V supply remains on and the 3.3 V supply goes to zero.

Table 20. VDIF Parameters

Symbol	Parameter	Min	Max	Units	Notes
VDIFF	VCC5-V _{CC} Difference		2.25	V	VCC5 input should not exceed V _{CC} by more than 2.25 V during power-up and power-down, or during steady-state operation.

4.5 VCCPLL Pin Requirements

To reduce clock skew on the i960 80960Jx processor, the VCCPLL pin for the Phase Lock Loop (PLL) circuit is isolated on the pinout. The lowpass filter, as shown in Figure 9, reduces noise induced clock jitter and its effects on timing relationships in system designs. The 4.7 μF capacitor must be low ESR solid tantalum; the 0.01 μF capacitor must be of the type X7R and the node connecting VCCPLL must be as short as possible.

Figure 9. VCCPLL Lowpass Filter

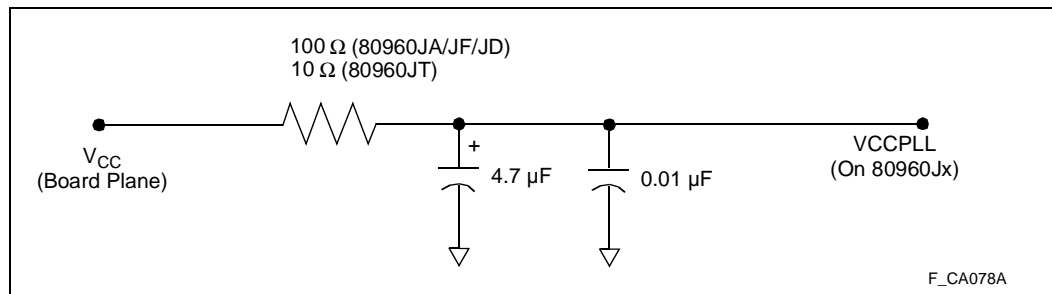

4.6 DC Specifications

Table 21. 80960Jx DC Characteristics

Symbol	Parameter	Min	Typ	Max	Units	Notes
V_{IL}	Input Low Voltage	-0.3		0.8	V	
V_{IH}	Input High Voltage	2.0		$V_{CC5} + 0.3$	V	
V_{OL}	Output Low Voltage			0.4 0.2	V V	$I_{OL} = 3 \text{ mA}$ $I_{OL} = 100 \mu\text{A}$
V_{OH}	Output High Voltage	2.4 $V_{CC} - 0.2$			V	$I_{OH} = -1 \text{ mA}$ $I_{OH} = -200 \mu\text{A}$
V_{OLP}	Output Ground Bounce		<0.8		V	(1,2)
C_{IN}	Input Capacitance PGA PQFP MPBGA			15 15 15	pF	$f_{CLKIN} = f_{MIN} (2)$
C_{OUT}	I/O or Output Capacitance PGA PQFP MPBGA			15 15 15	pF	$f_{CLKIN} = f_{MIN} (2)$
C_{CLK}	CLKIN Capacitance PGA PQFP MPBGA			15 15 15	pF	$f_{CLKIN} = f_{MIN} (2)$

NOTES:

1. Typical is measured with $V_{CC} = 3.3 \text{ V}$ and temperature = $25 \text{ }^\circ\text{C}$.
2. Not tested.

Table 22. 80960Jx I_{CC} Characteristics (Sheet 1 of 2)

Symbol	Parameter	Typ	Max	Units	Notes
I_{LI1}	Input Leakage Current for each pin except TCK, TDI, TRST# and TMS		± 1	μA	$0 \leq V_{IN} \leq V_{CC}$
I_{LI2}	Input Leakage Current for TCK, TDI, TRST# and TMS	-140	-250	μA	$V_{IN} = 0.45\text{V} (1)$
I_{LO}	Output Leakage Current		± 1	μA	$0.4 \leq V_{OUT} \leq V_{CC}$
R_{pu}	Internal Pull-UP Resistance for ONCE#, TMS, TDI and TRST#	20	30	k Ω	
I_{CC} Active (Power Supply)	80960JT-100 80960JD-66 80960JD-50 80960JD-40 80960JD-33 80960JA/JF-33 80960JA/JF-25 revised 7/98 80960JA/JF-16 revised 7/98		600 580 447 367 310 320 241 154	mA	(2,3) (2,3) (2,3) (2,3) (2,3) (2,3) (2,3) (2,3)

Table 22. 80960Jx I_{CC} Characteristics (Sheet 2 of 2)

Symbol	Parameter	Typ	Max	Units	Notes	
I _{CC} Active (Thermal)	80960JT-100	500		mA	(2,4)	
	80960JD-66	510			(2,4)	
	80960JD-50	390			(2,4)	
	80960JD-40	320			(2,4)	
	80960JD-33	260			(2,4)	
	80960JA/JF-33	271			(2,4)	
	80960JA/JF-25	215			(2,4)	
	80960JA/JF-16	152			(2,4)	
I _{CC} Test (Power modes)	Reset mode			mA		
	80960JT-100		450		(5)	
	80960JD-66		475		(5)	
	80960JD-50		425		(5)	
	80960JD-40		345		(5)	
	80960JD-33		300		(5)	
	80960JA/JF-33		250		(5)	
	80960JA/JF-25		200		(5)	
	80960JA/JF-16		150		(5)	
	Halt mode					
	80960JT-100		50		(5)	
	80960JD-66		50		(5)	
	80960JD-50		40		(5)	
	80960JD-40		34		(5)	
	80960JD-33		34		(5)	
	80960JA/JF-33		31		(5)	
	80960JA/JF-25		26		(5)	
	80960JA/JF-16		21		(5)	
	ONCE mode				10	(5)
I _{CC5} Current on the VCC5 Pin	80960JT-100		200	μA	(6)	
	80960JD-66				(6)	
	80960JD-50				(6)	
	80960JD-40				(6)	
	80960JD-33				(6)	
	80960JA/JF-33				(6)	
	80960JA/JF-25				(6)	
	80960JA/JF-16				(6)	

NOTES:

1. These pins have internal pullup devices. Typical leakage current is not tested.
2. Measured with device operating and outputs loaded to the test condition in Figure 10 "AC Test Load" on page 47.
3. I_{CC} Active (Power Supply) value is provided for selecting your system's power supply. It is measured using one of the worst case instruction mixes with V_{CC} = 3.45 V. This parameter is characterized but not tested.
4. I_{CC} Active (Thermal) value is provided for your system's thermal management. Typical I_{CC} is measured with V_{CC} = 3.3 V and temperature = 25°C. This parameter is characterized but not tested.
5. I_{CC} Test (Power modes) refers to the I_{CC} values that are tested when the 80960JD is in Reset mode, Halt mode or ONCE mode with V_{CC} = 3.45 V.
6. I_{CC5} is tested at V_{CC} = 3.3 V, VCC5 = 5.25 V.

4.7 AC Specifications

The 80960Jx AC timings are based upon device characterization.

Table 23. 80960Jx AC Characteristics (Sheet 1 of 3)

Symbol	Parameter	Min	Max	Unit	Notes
INPUT CLOCK TIMINGS					
T_F	CLKIN Frequency				
	80960JT-100	15	33.3	MHz	
	80960JD-66	12	33.3		
	80960JD-50	12	25		
	80960JD-40	12	20		
	80960JD-33	12	16.67		
	80960JA/JF-33	12	33.3		
	80960JA/JF-25	12	25		
80960JA/JF-16	12	16			
T_C	CLKIN Period			ns	
	80960JT-100	30	66.7		
	80960JD-66	30	83.3		
	80960JD-50	40	83.3		
	80960JD-40	50	83.3		
	80960JD-33	60	83.3		
	80960JA/JF-33	30	83.3		
	80960JA/JF-25	40	83.3		
80960JA/JF-16	62.5	83.3			
T_{CS}	CLKIN Period Stability		± 250	ps	(1, 2)
T_{CH}	CLKIN High Time	8		ns	Measured at 1.5 V (1)
T_{CL}	CLKIN Low Time	8		ns	Measured at 1.5 V (1)
T_{CR}	CLKIN Rise Time		4	ns	0.8 V to 2.0 V (1)
T_{CF}	CLKIN Fall Time		4	ns	2.0 V to 0.8 V (1)
SYNCHRONOUS OUTPUT TIMINGS					
T_{OV1}	Output Valid Delay, Except ALE/ALE# Inactive and DT/R# for 3.3 V input signals	2.5	13.5	ns	(3)
	Same as above, but for 5.5 V input signals	2.5	16.5		
T_{OV2}	Output Valid Delay, DT/R#			ns	
	80960JT	$0.5T_C + 7$	$0.5T_C + 9$		
	80960JD 80960JA/JF	$0.5T_C + 7$ $0.5T_C + 4$	$0.5T_C + 9$ $0.5T_C + 18$		
T_{OF}	Output Float Delay	2.5	13.5	ns	(4)

NOTE: See Table 24 on page 46 for note definitions for this table.

Table 23. 80960Jx AC Characteristics (Sheet 2 of 3)

Symbol	Parameter	Min	Max	Unit	Notes
SYNCHRONOUS INPUT TIMINGS					
T _{IS1}	Input Setup to CLKIN — AD[31:0], NMI#, XINT[7:0]#				
	80960JT	6		ns	(5)
	80960JD 80960JA/JF	6 9			
T _{IH1}	Input Hold from CLKIN — AD[31:0], NMI#, XINT[7:0]#				
	80960JT	1.5		ns	(5)
	80960JD 80960JA/JF	1.5 1.0			
T _{IS2}	Input Setup to CLKIN — RDYRCV# and HOLD				
	80960JT	6.5		ns	(6)
	80960JD 80960JA/JF	6.5 10.0			
T _{IH2}	Input Hold from CLKIN — RDYRCV# and HOLD	1		ns	(6)
T _{IS3}	Input Setup to CLKIN — RESET#				
	80960JT	7		ns	(7)
	80960JD 80960JA/JF	7 8			
T _{IH3}	Input Hold from CLKIN — RESET#				
	80960JT	2		ns	(7)
	80960JD 80960JA/JF	2 1			
T _{IS4}	Input Setup to RESET# — ONCE#, STEST				
	80960JT	7		ns	(8)
	80960JD 80960JA/JF	7 8			
T _{IH4}	Input Hold from RESET# — ONCE#, STEST				
	80960JT	2		ns	(8)
	80960JD 80960JA/JF	2 1			
RELATIVE OUTPUT TIMINGS					
T _{LX}	Address Valid to ALE/ALE# Inactive For 3.3 V Data Input Signals For 5.0 V Data Input Signals	0.5T _C - 5 0.5T _C - 8		ns	(9)
T _{LXL}	ALE/ALE# Width	0.5T _C - 7		ns	Equal Loading (9)
T _{LXA}	Address Hold from ALE/ALE# Inactive				
T _{DXD}	DT/R# Valid to DEN# Active				
BOUNDARY SCAN TEST SIGNAL TIMINGS					
T _{BSF}	TCK Frequency		0.5T _F	MHz	
T _{BSCH}	TCK High Time	15		ns	Measured at 1.5 V (1)
T _{BSCL}	TCK Low Time	15		ns	Measured at 1.5 V (1)
T _{BSCR}	TCK Rise Time		5	ns	0.8 V to 2.0 V (1)
T _{BSCF}	TCK Fall Time		5	ns	2.0 V to 0.8 V (1)
T _{BSIS1}	Input Setup to TCK — TDI, TMS	4		ns	

NOTE: See Table 24 on page 46 for note definitions for this table.

Table 23. 80960Jx AC Characteristics (Sheet 3 of 3)

Symbol	Parameter	Min	Max	Unit	Notes
T_{BSIH1}	Input Hold from TCK — TDI, TMS	6		ns	
T_{BSOV1}	TDO Valid Delay	3	30	ns	(1,10)
T_{BSOF1}	TDO Float Delay	3	30	ns	(1,10)
T_{BSOV2}	All Outputs (Non-Test) Valid Delay	3	30	ns	(1,10)
T_{BSOF2}	All Outputs (Non-Test) Float Delay	3	30	ns	(1,10)
T_{BSIS2}	Input Setup to TCK — All Inputs (Non-Test)	4		ns	
T_{BSIH2}	Input Hold from TCK — All Inputs (Non-Test)	6		ns	

NOTE: See Table 24 on page 46 for note definitions for this table.

Table 24. Note Definitions for Table 23, 80960Jx AC Characteristics (pg. 44)

<p>NOTES:</p> <ol style="list-style-type: none"> Not tested. To ensure a 1:1 relationship between the amplitude of the input jitter and the internal clock, the jitter frequency spectrum should not have any power peaking between 500 KHz and 1/3 of the CLKIN frequency. Inactive ALE/ALE# refers to the falling edge of ALE and the rising edge of ALE#. For inactive ALE/ALE# timings, refer to Relative Output Timings in this table. A float condition occurs when the output current becomes less than I_{OL}. Float delay is not tested, but is designed to be no longer than the valid delay. AD[31:0] are synchronous inputs. Setup and hold times must be met for proper processor operation. NMI# and XINT[7:0]# may be synchronous or asynchronous. Meeting setup and hold time guarantees recognition at a particular clock edge. For asynchronous operation, NMI# and XINT[7:0]# must be asserted for a minimum of two CLKIN periods to guarantee recognition. RDYRCV# and HOLD are synchronous inputs. Setup and hold times must be met for proper processor operation. RESET# may be synchronous or asynchronous. Meeting setup and hold time guarantees recognition at a particular clock edge. ONCE# and STEST# must be stable at the rising edge of RESET# for proper operation. Guaranteed by design. May not be 100% tested. Relative to falling edge of TCK. Worst-case T_{OV} condition occurs on I/O pins when pins transition from a floating high input to driving a low output state. The Address/Data Bus pins encounter this condition between the last access of a read, and the address cycle of a following write. 5 V signals take 3 ns longer to discharge than 3.3 V signals at 50 pF loads.

4.7.1 AC Test Conditions and Derating Curves

The AC Specifications in Section 4.7, “AC Specifications” are tested with the 50 pF load indicated in Figure 10. Figure 13 shows how timings and output rise and fall times vary with load capacitance.

Figure 10. AC Test Load

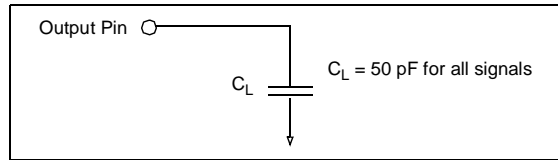

Figure 11. Output Delay or Hold vs. Load Capacitance – 80960JT Processor (3.3 V Signals)

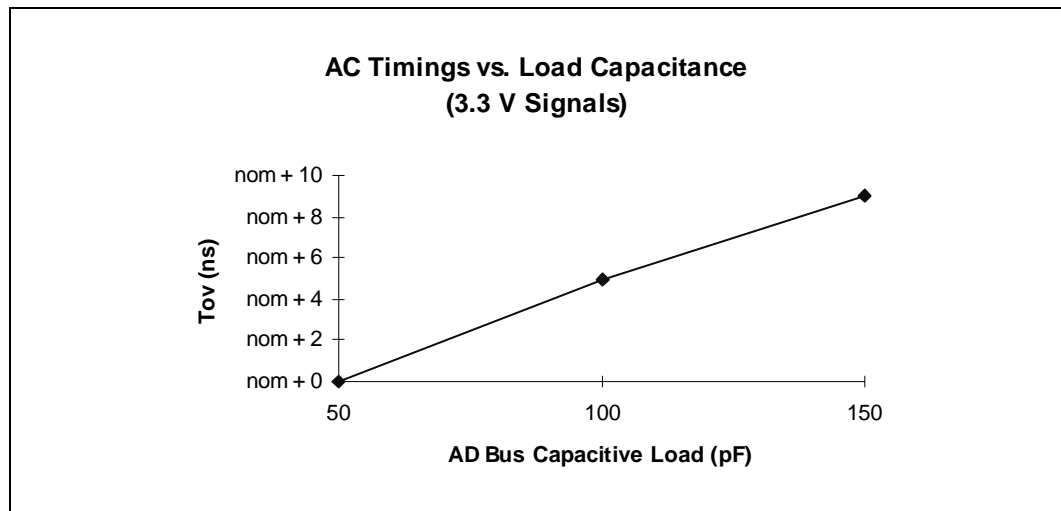

Figure 12. Output Delay or Hold vs. Load Capacitance – 80960JT Processor (5 V Signals)

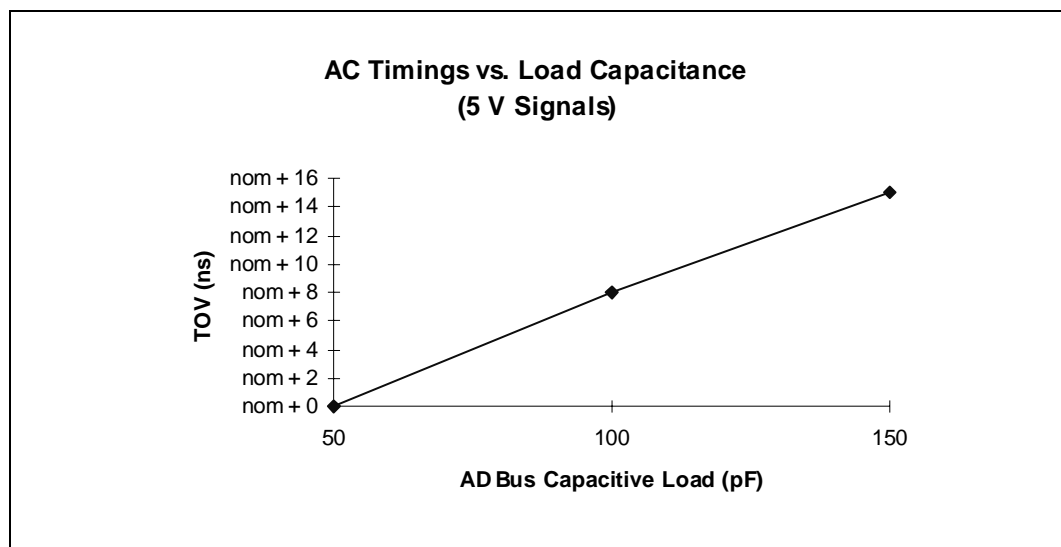

Figure 13. Output Delay or Hold vs. Load Capacitance – 80960JA/JF/JD Processors

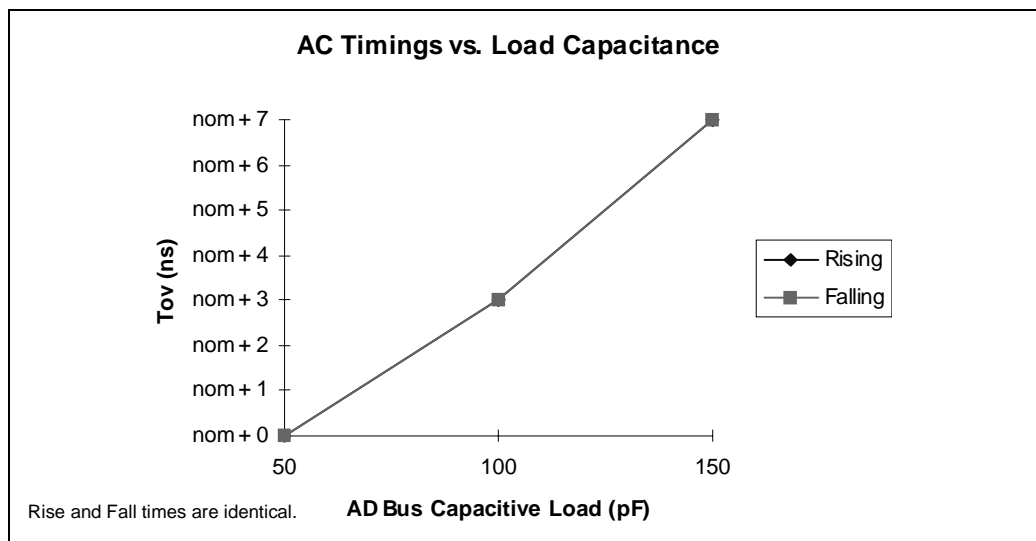
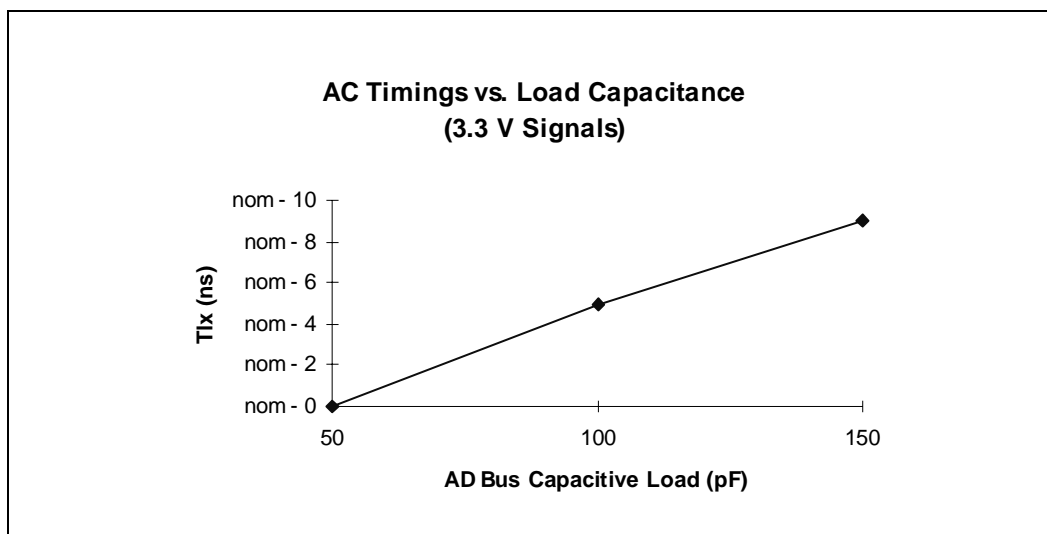
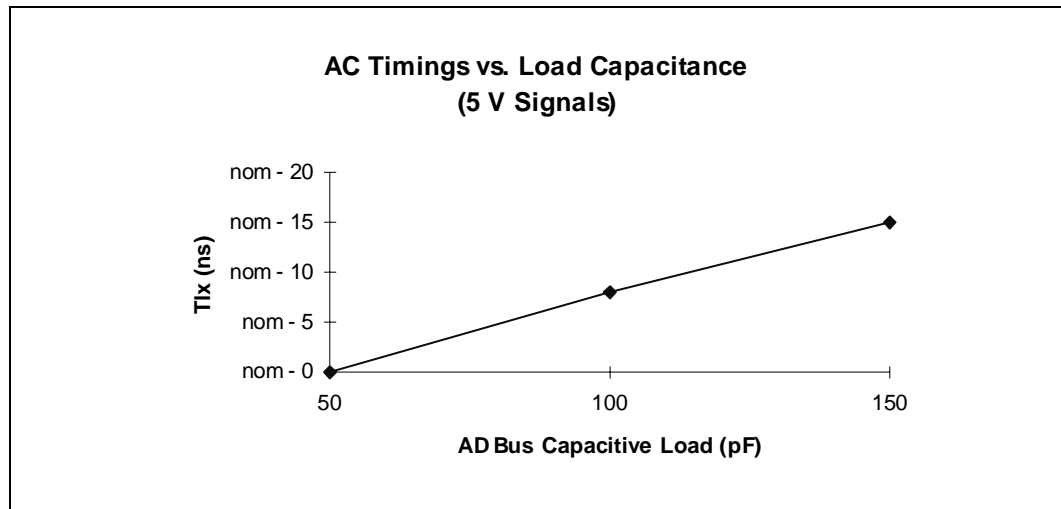

Figure 14. T_{LX} vs. AD Bus Load Capacitance – 80960JT Processor (3.3 V Signals)



Note: The T_{LX} Derating curve applies only when an imbalance in the capacitive load occurs between the AD bus and ALE. The T_{LX} derating is based on a 50 pF load on ALE. The derating applies to ALE and ALE#.

Figure 15. T_{LX} vs. AD Bus Load Capacitance – 80960JT Processor (5 V Signals)



Note: The T_{LX} Derating curve applies only when an imbalance in the capacitive load occurs between the AD bus and ALE. The T_{LX} derating is based on a 50 pF load on ALE. The derating applies to ALE and ALE#.

Figure 16. T_{LX} vs. AD Bus Load Capacitance – 80960JA/JF/JD Processors

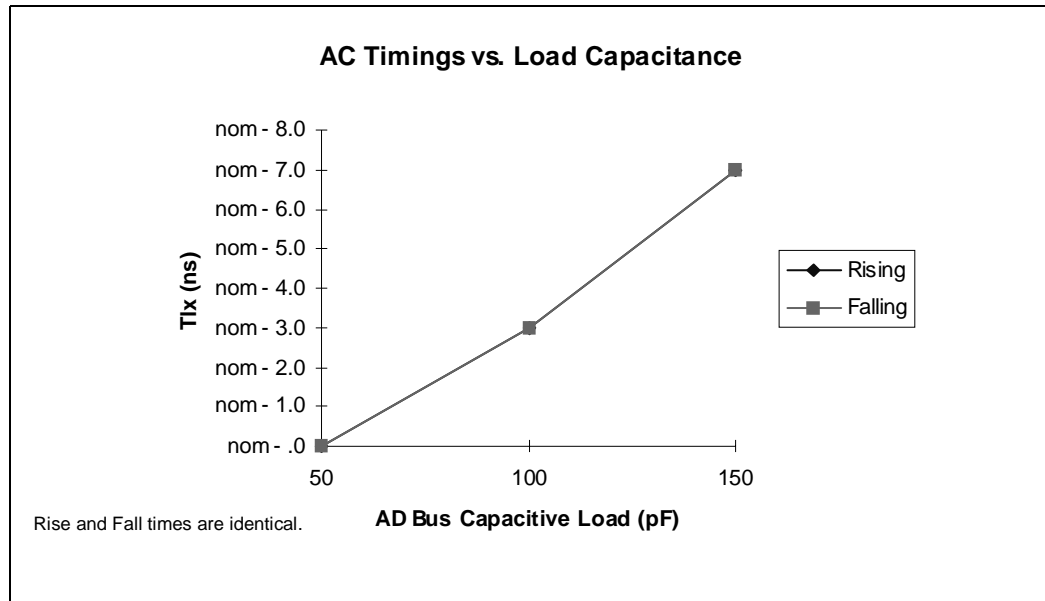

Note: The T_{LX} Derating curve applies only when an imbalance in the capacitive load occurs between the AD bus and ALE. The T_{LX} derating is based on a 50 pF load on ALE. The derating applies to ALE and ALE#.

Figure 17. 80960JA/JF I_{CC} Active (Power Supply) vs. Frequency

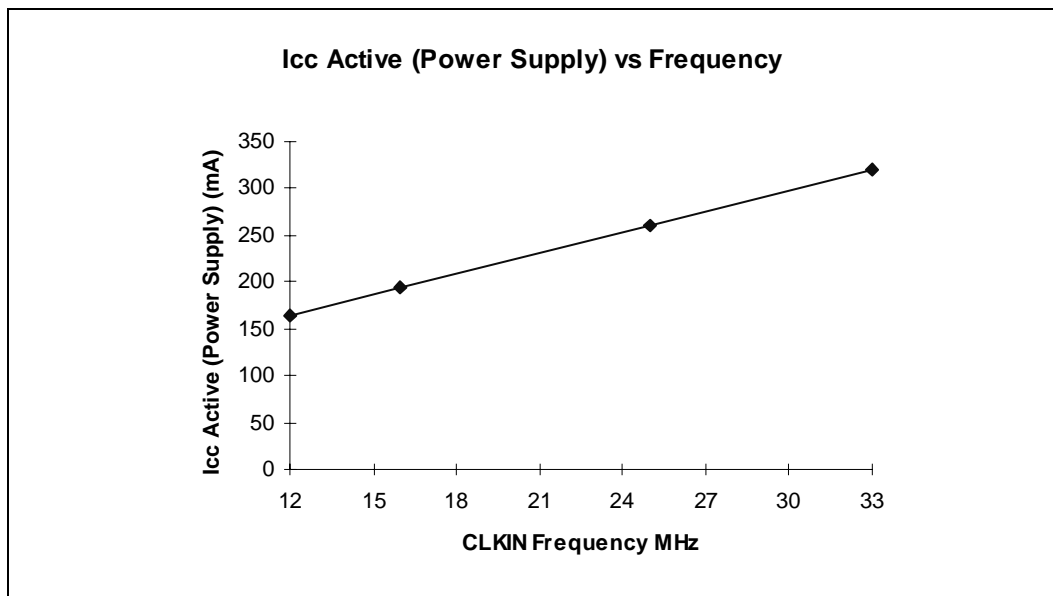

Figure 18. 80960JA/JF I_{CC} Active (Thermal) vs. Frequency

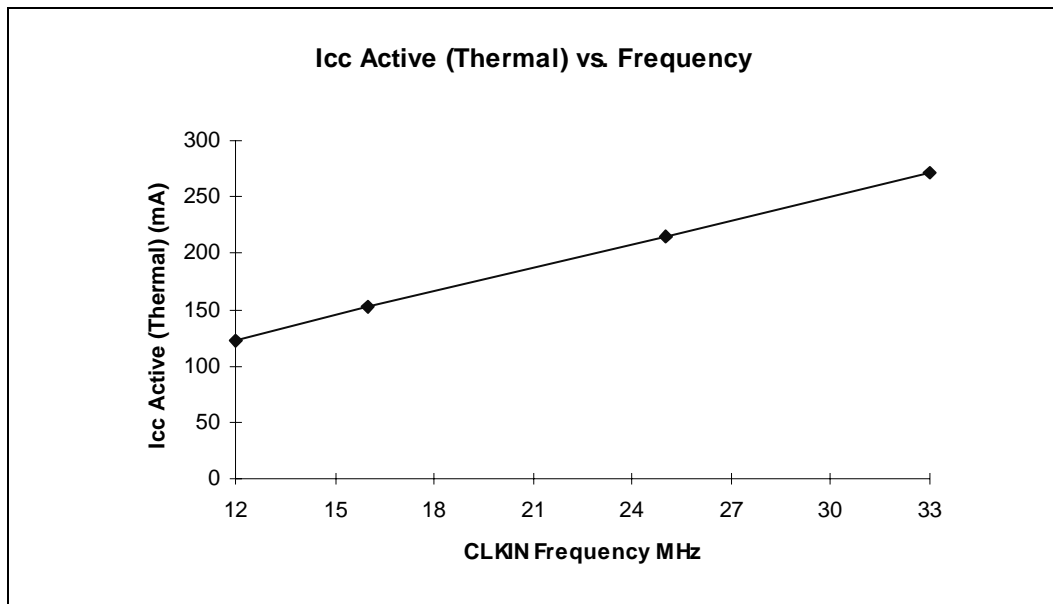

Figure 19. 80960JD I_{CC} Active (Power Supply) vs. Frequency

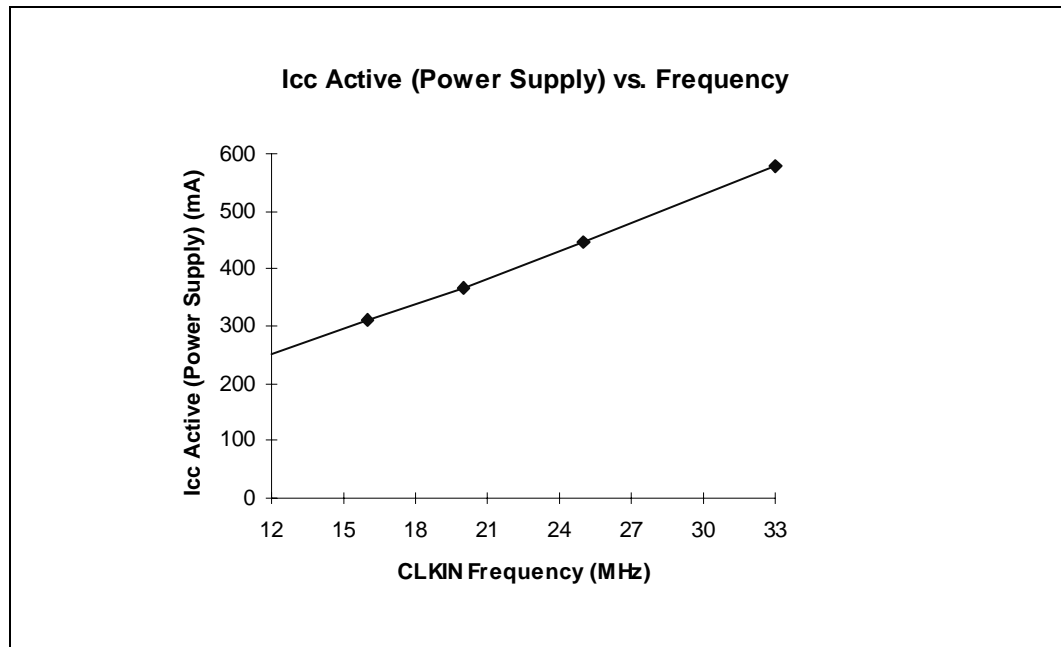

Figure 20. 80960JD I_{CC} Active (Thermal) vs. Frequency

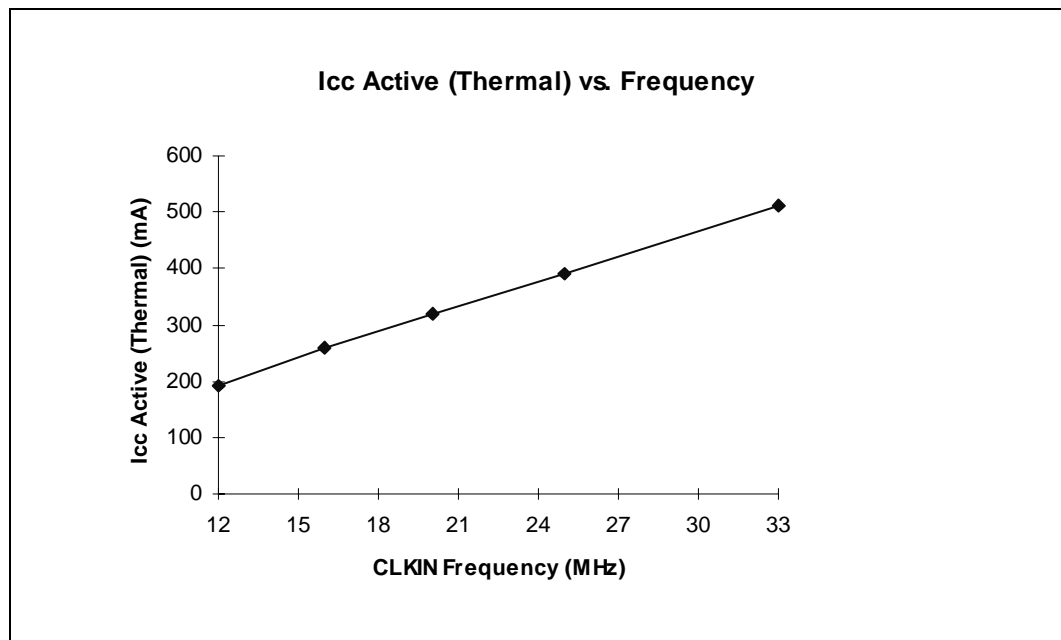

Figure 21. 80960JT I_{CC} Active (Power Supply) vs. Frequency

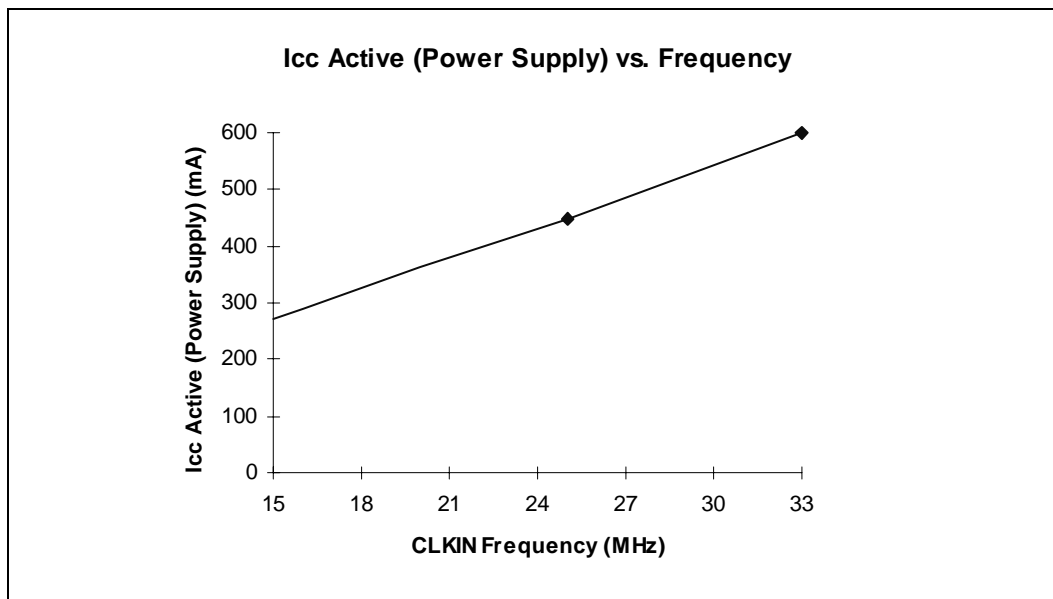
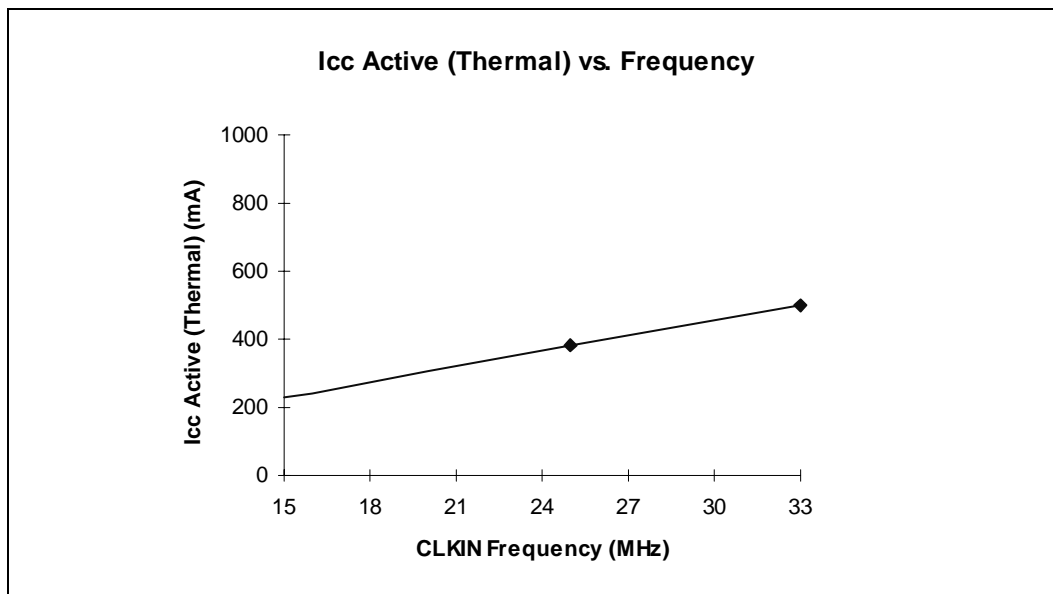

Figure 22. 80960JT I_{CC} Active (Thermal) vs. Frequency



4.7.2 AC Timing Waveforms

Figure 23. CLKIN Waveform

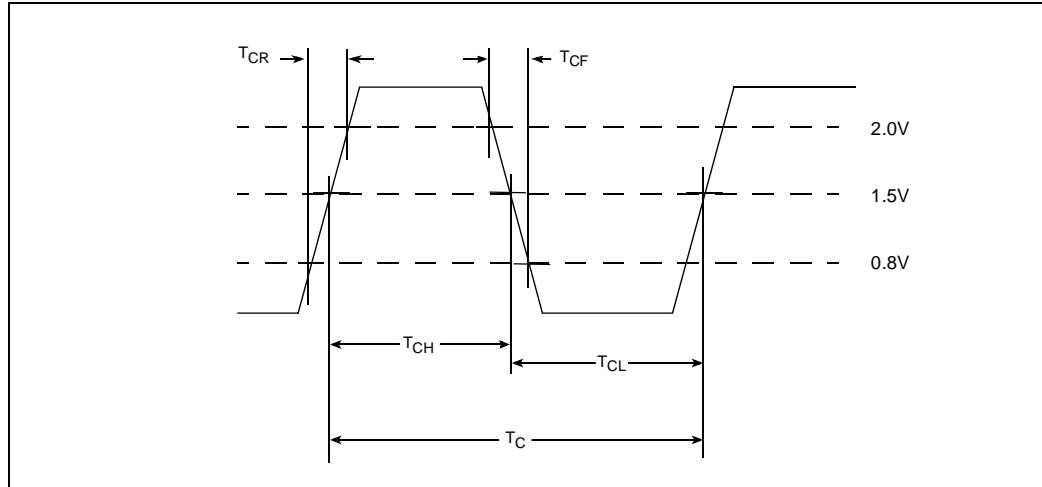

Figure 24. T_{OV1} Output Delay Waveform

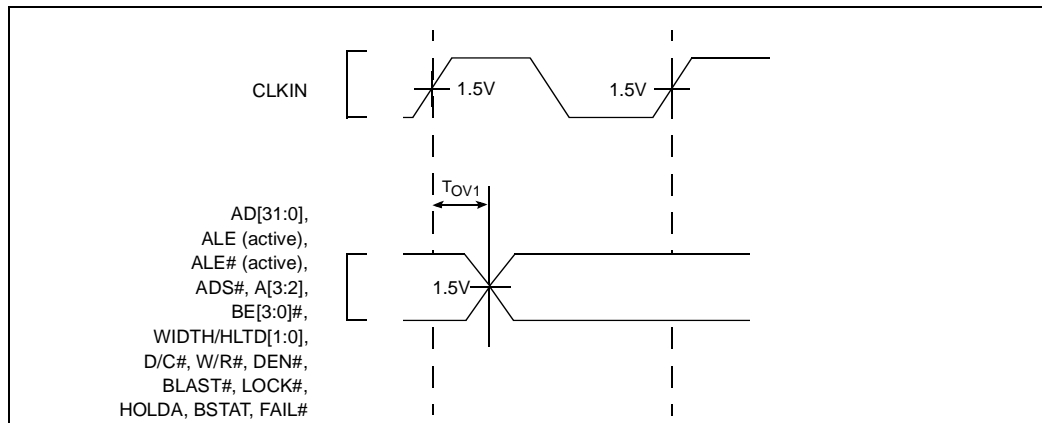

Figure 25. T_{OF} Output Float Waveform

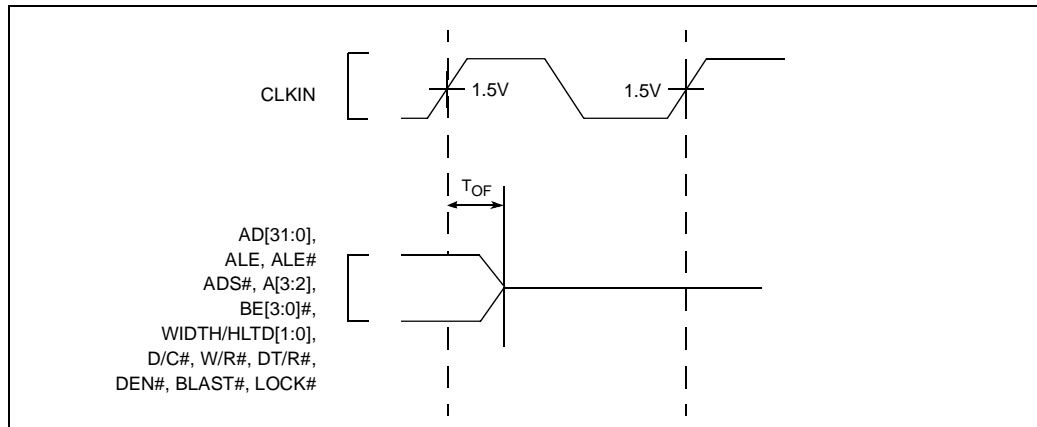

Figure 26. T_{IS1} and T_{IH1} Input Setup and Hold Waveform

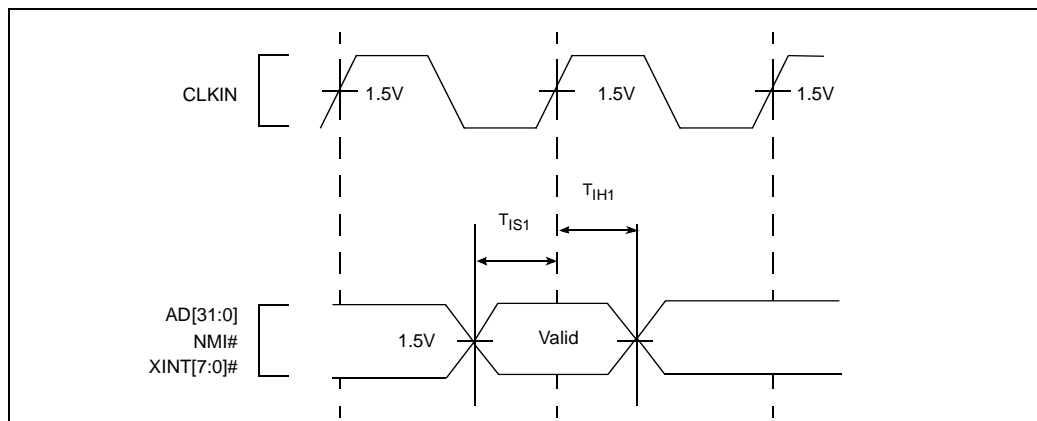

Figure 27. T_{IS2} and T_{IH2} Input Setup and Hold Waveform

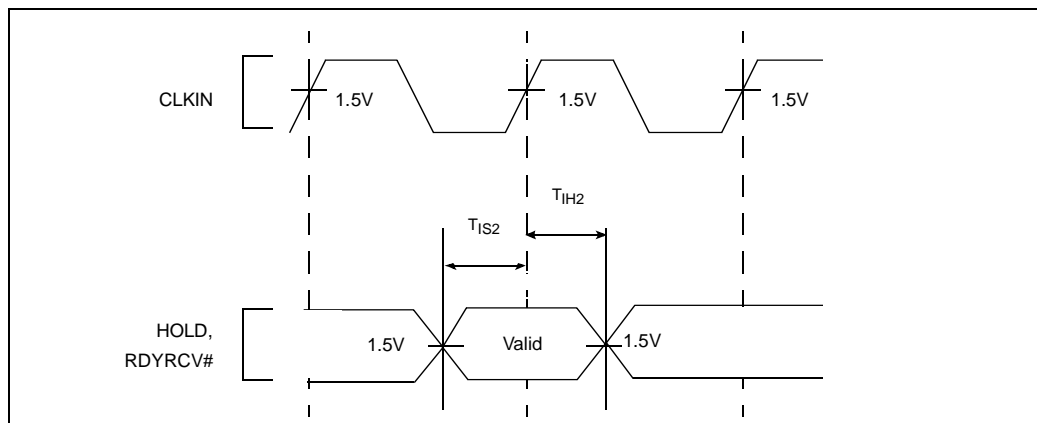

Figure 28. T_{IS3} and T_{IH3} Input Setup and Hold Waveform

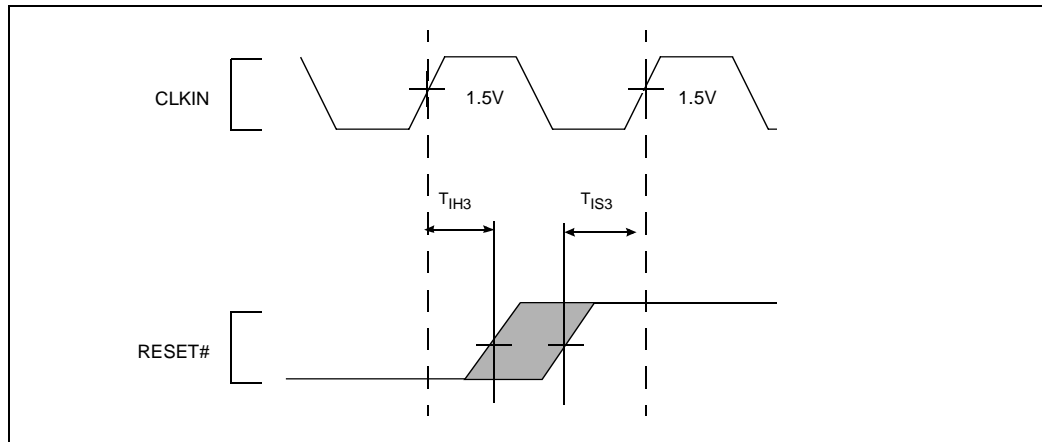

Figure 29. T_{IS4} and T_{IH4} Input Setup and Hold Waveform

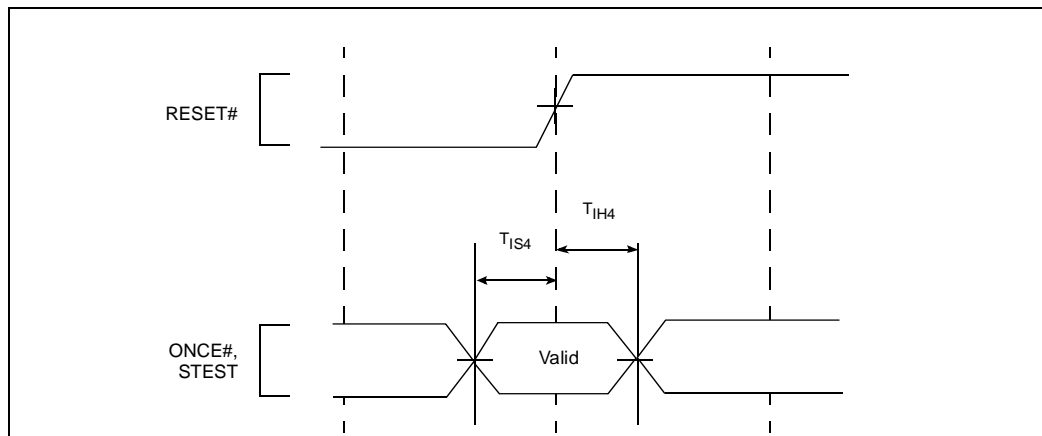

Figure 30. T_{LX} , T_{LXL} and T_{LXA} Relative Timings Waveform

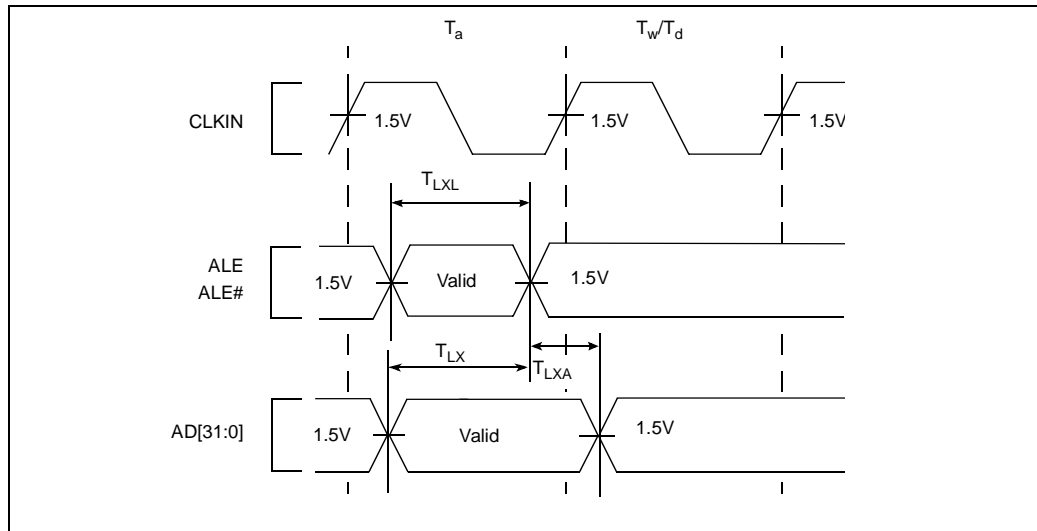

Figure 31. DT/R# and DEN# Timings Waveform

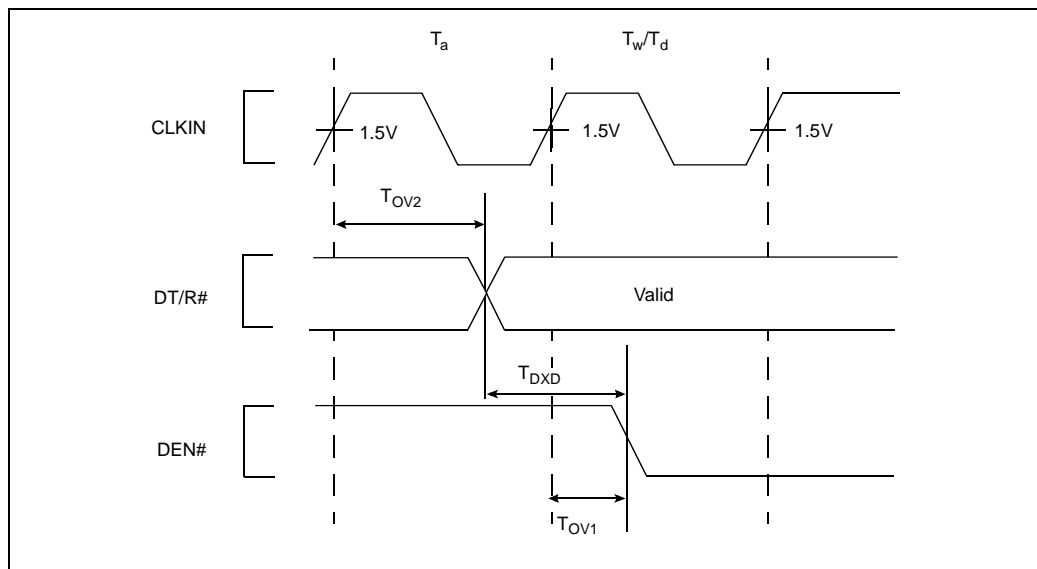

Figure 32. TCK Waveform

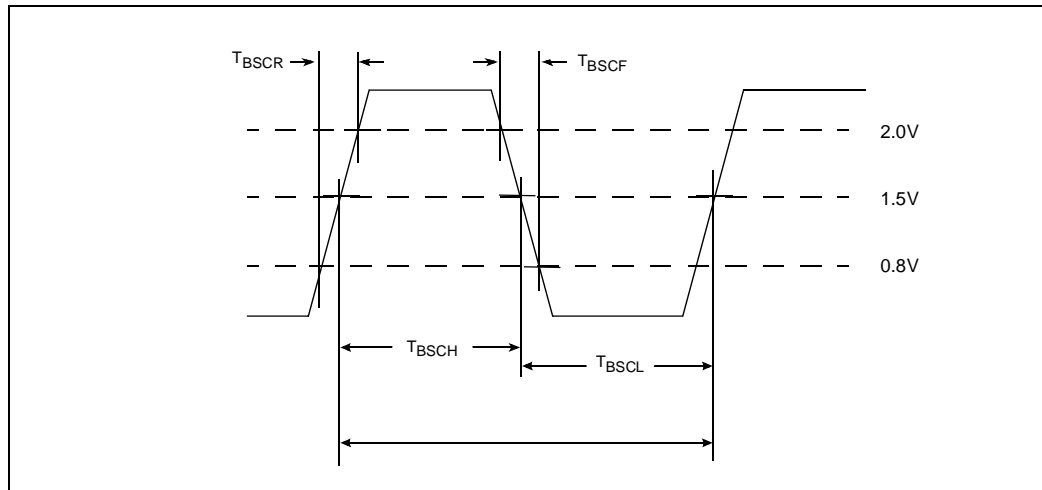

Figure 33. T_{BSIS1} and T_{BSIH1} Input Setup and Hold Waveforms

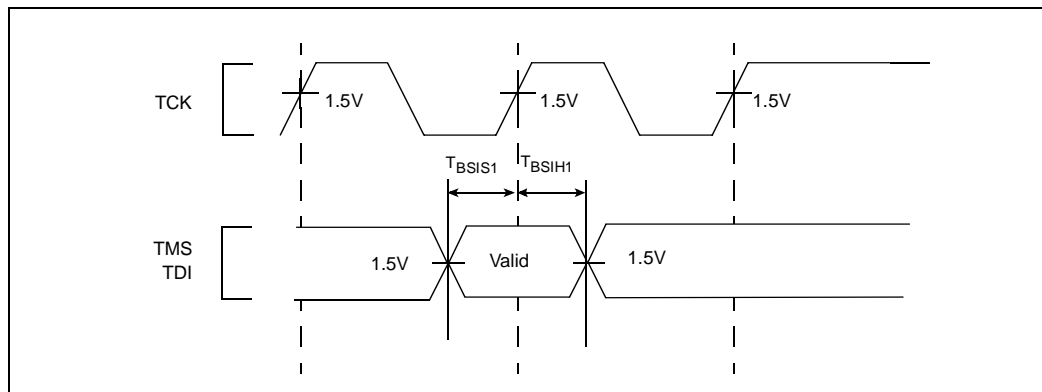

Figure 34. T_{BSOV1} and T_{BSOF1} Output Delay and Output Float Waveform

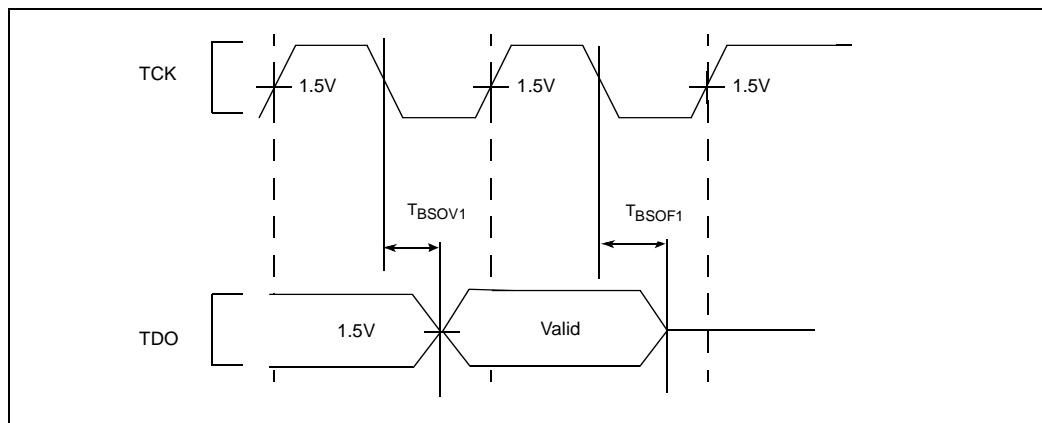

Figure 35. T_{BSOV2} and T_{BSOF2} Output Delay and Output Float Waveform

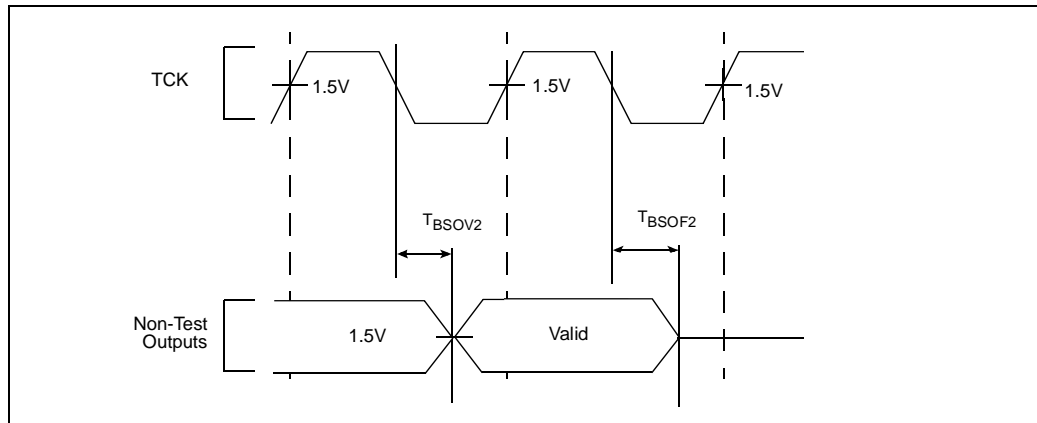
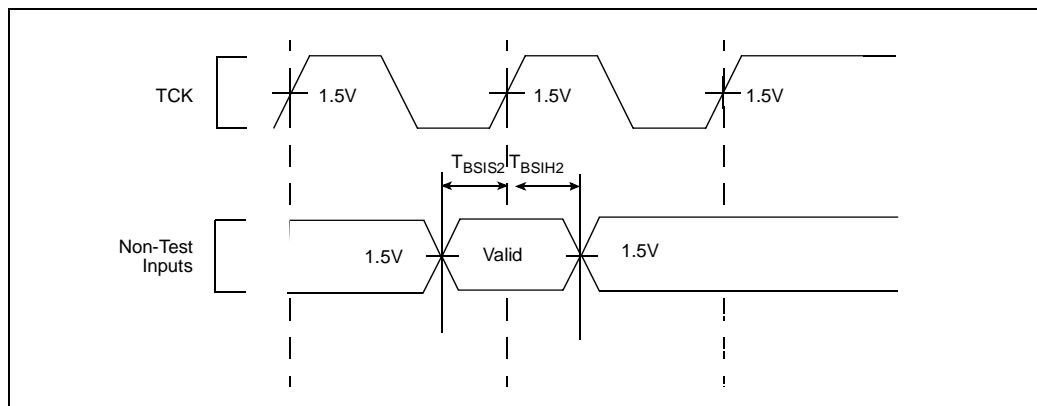

Figure 36. T_{BSIS2} and T_{BSIH2} Input Setup and Hold Waveform



5.0 Bus Functional Waveforms

Figure 37 through Figure 42 illustrate typical 80960Jx bus transactions. Figure 43 depicts the bus arbitration sequence. Figure 44 illustrates the processor reset sequence from the time power is applied to the device. Figure 45 illustrates the processor reset sequence when the processor is in operation. Figure 46 illustrates the processor ONCE# sequence from the time power is applied to the device. Figure 48 and Figure 49 also show accesses on 32-bit buses. Table 27 through Table 29 summarize all possible combinations of bus accesses across 8-, 16-, and 32-bit buses according to data alignment.

Figure 37. Non-Burst Read and Write Transactions Without Wait States, 32-Bit Bus

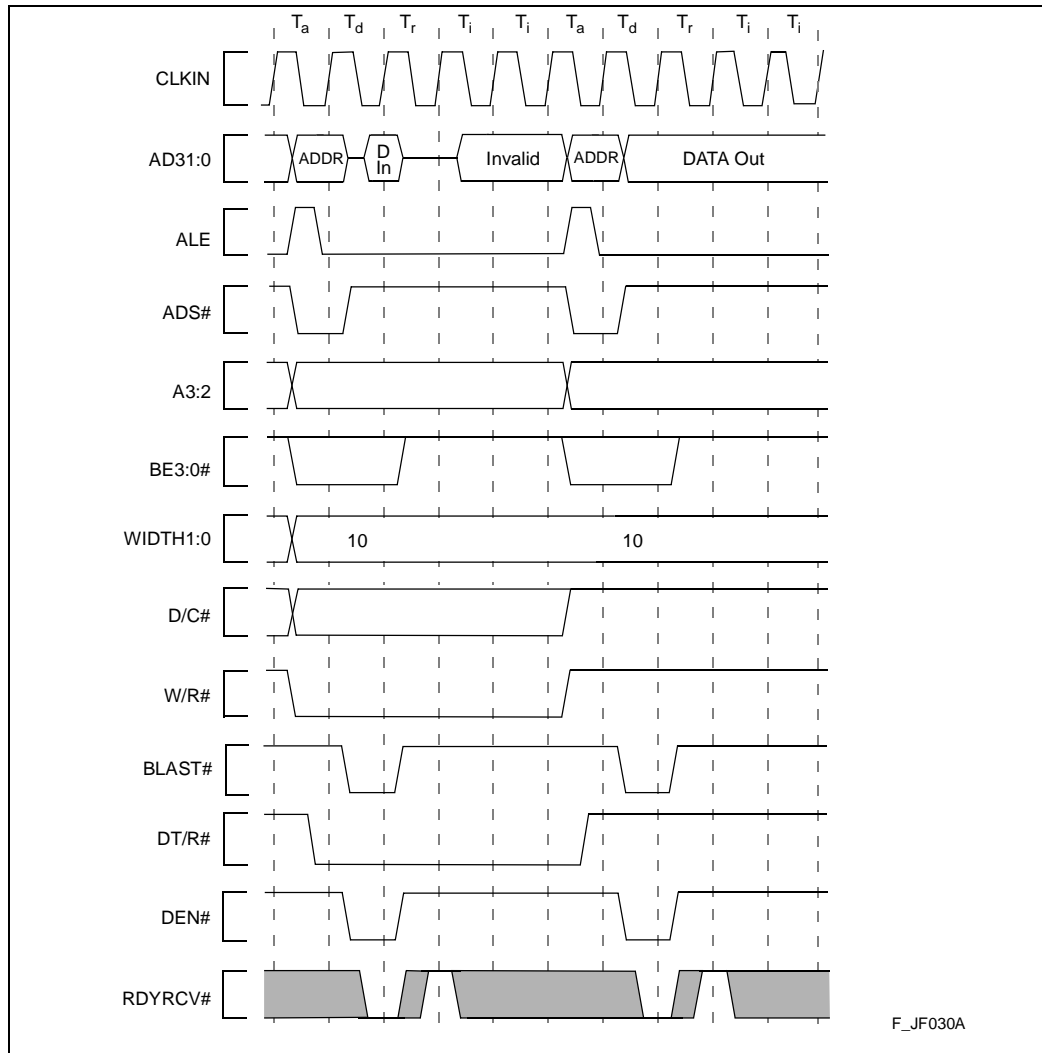

Figure 38. Burst Read and Write Transactions Without Wait States, 32-Bit Bus

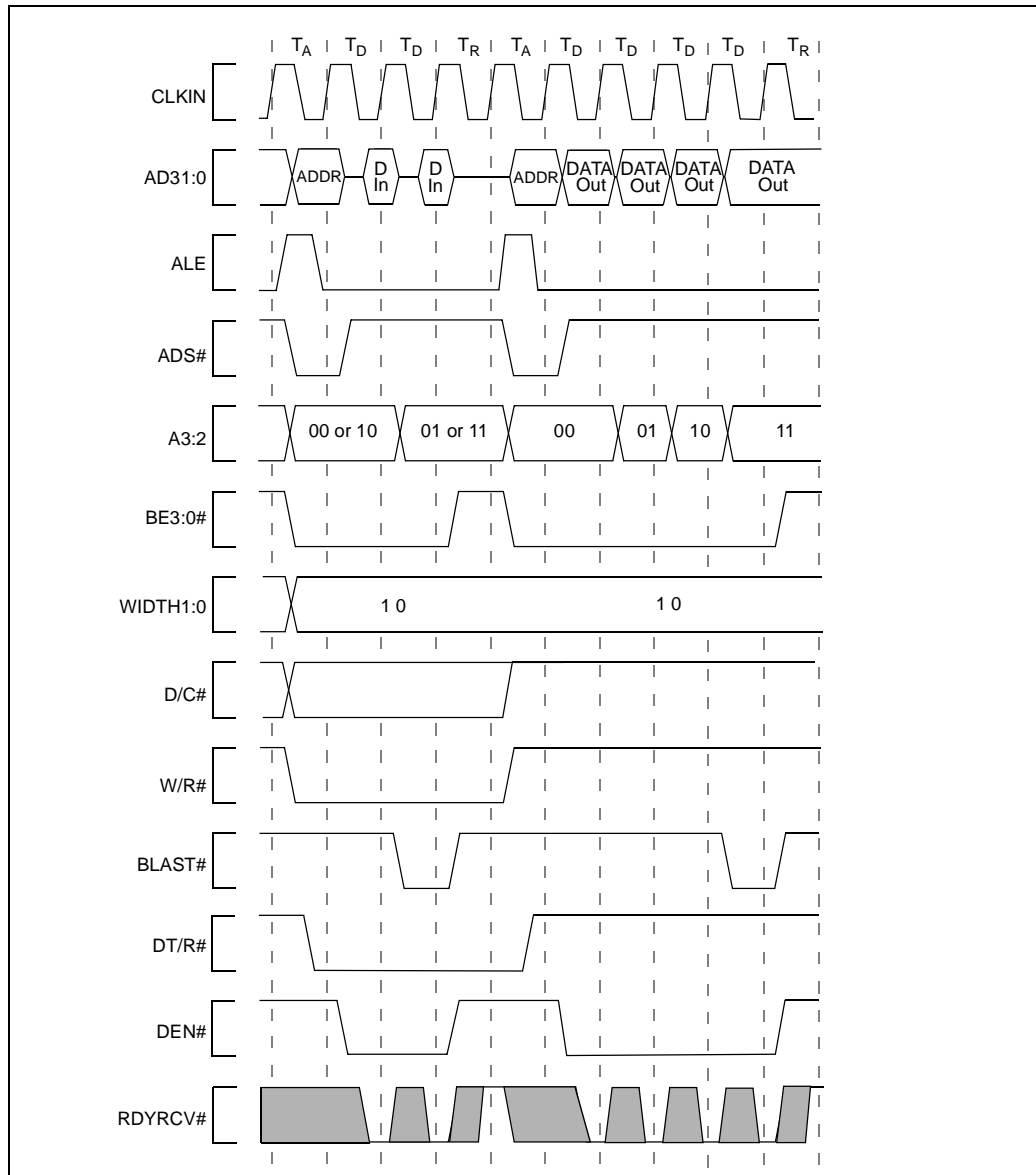

Figure 39. Burst Write Transactions With 2,1,1,1 Wait States, 32-Bit Bus

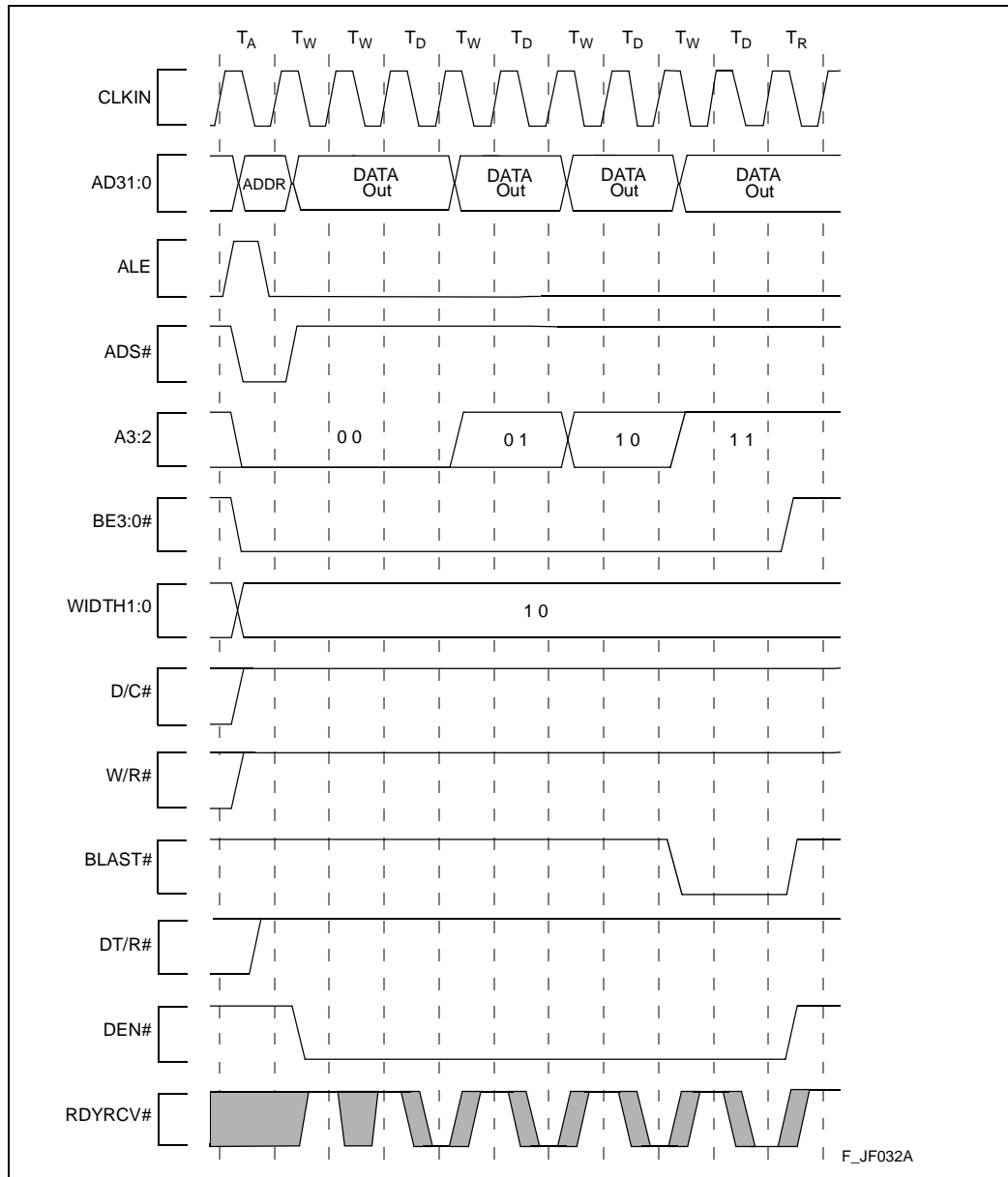

Figure 40. Burst Read and Write Transactions Without Wait States, 8-Bit Bus

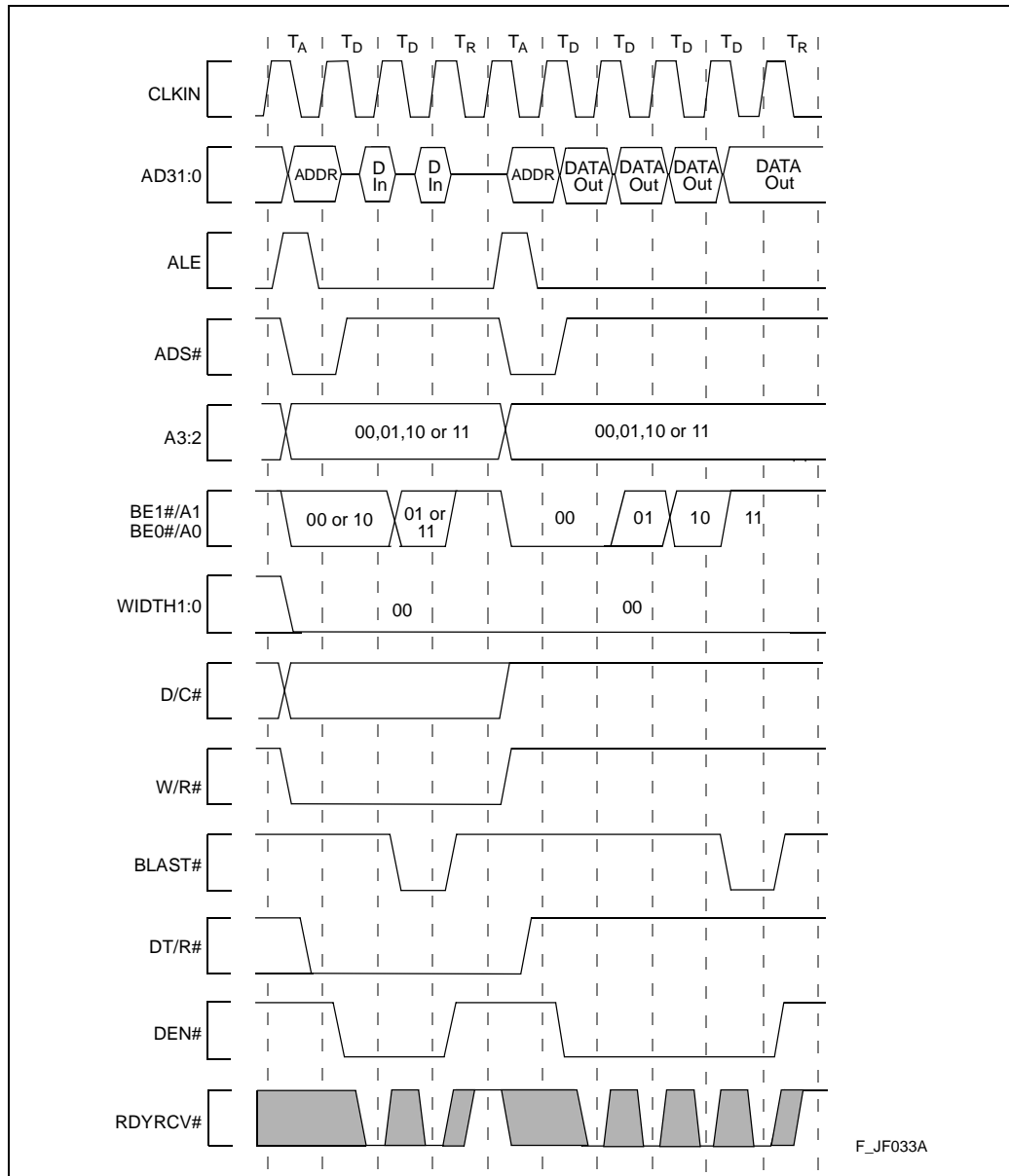

Figure 41. Burst Read and Write Transactions With 1, 0 Wait States and Extra Tr State on Read, 16-Bit Bus

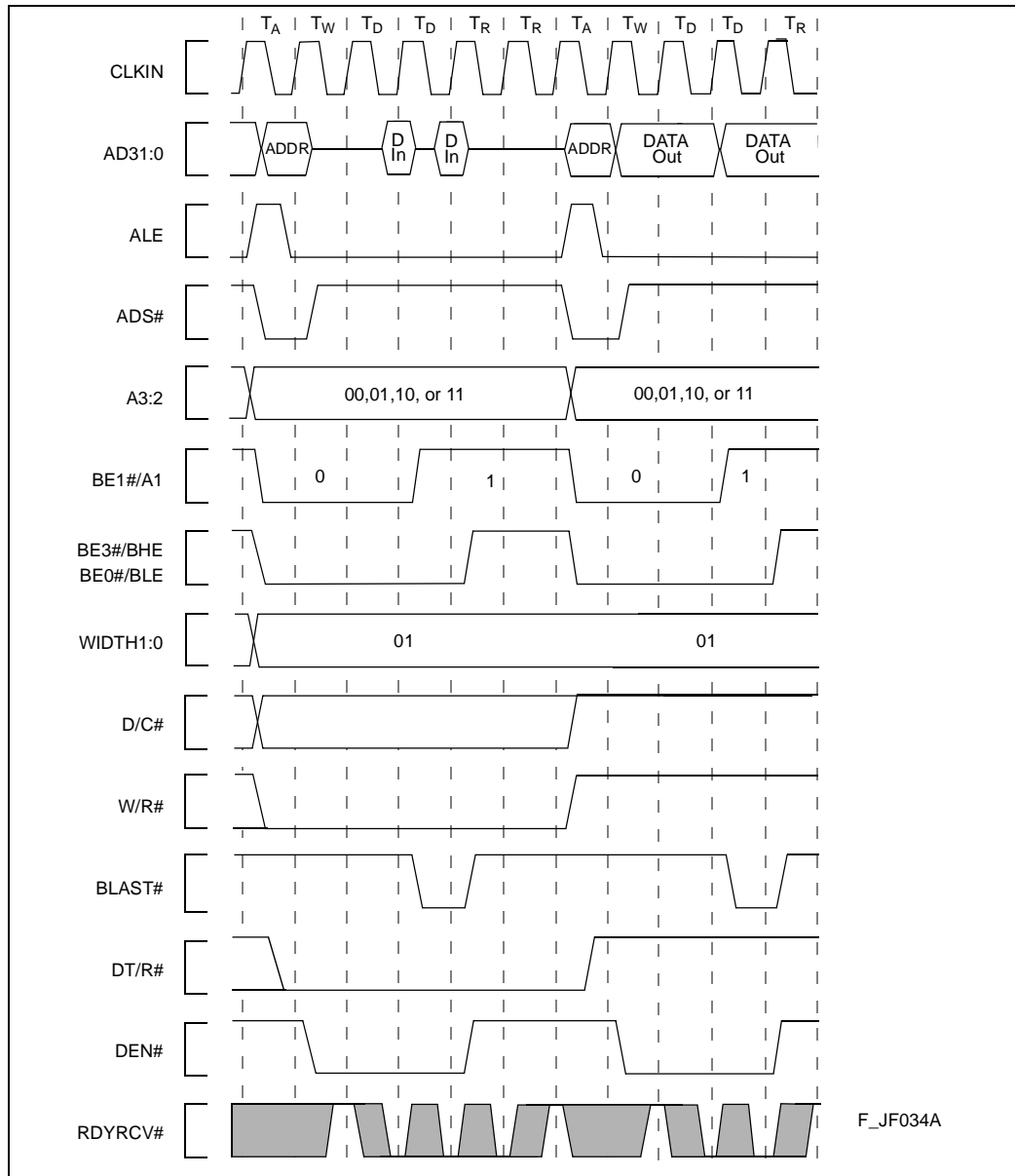

Figure 42. Double Word Read Bus Request, Misaligned One Byte From Quad Word Boundary, 32-Bit Bus, Little Endian

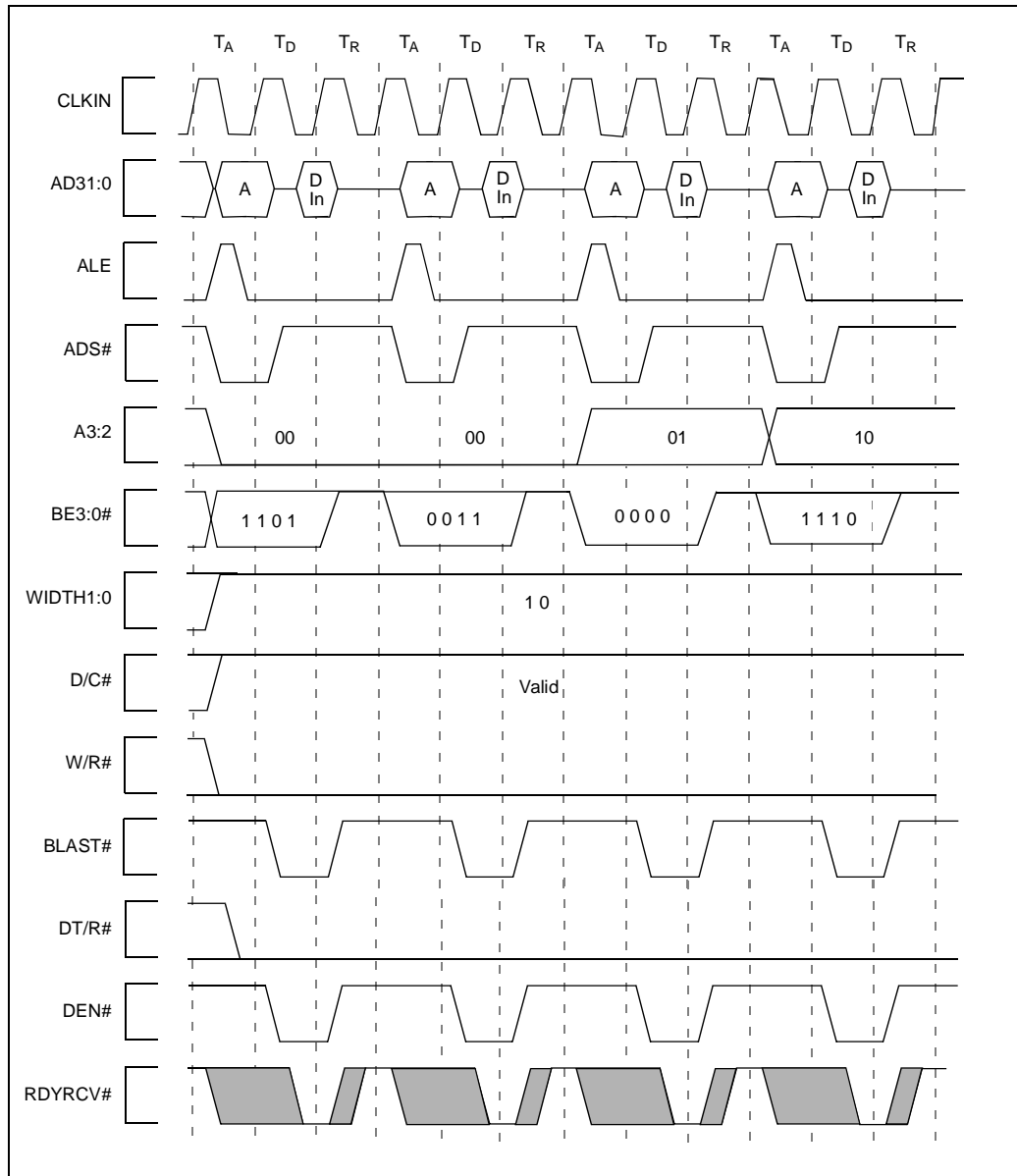

Figure 43. HOLD/HOLDA Waveform For Bus Arbitration

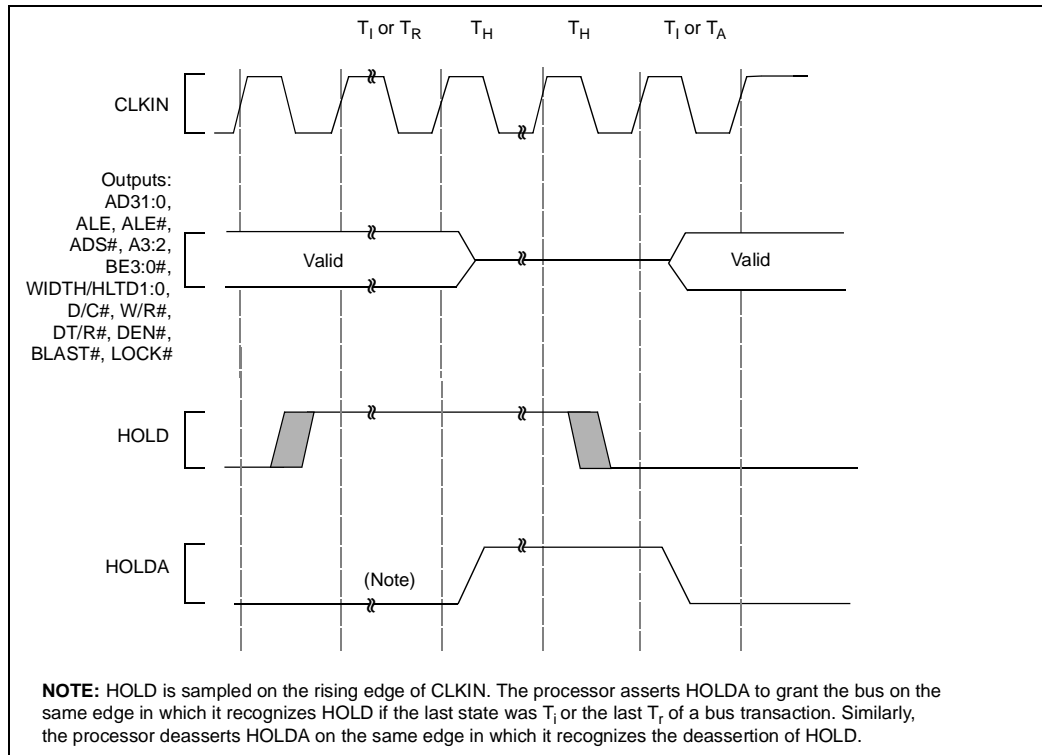
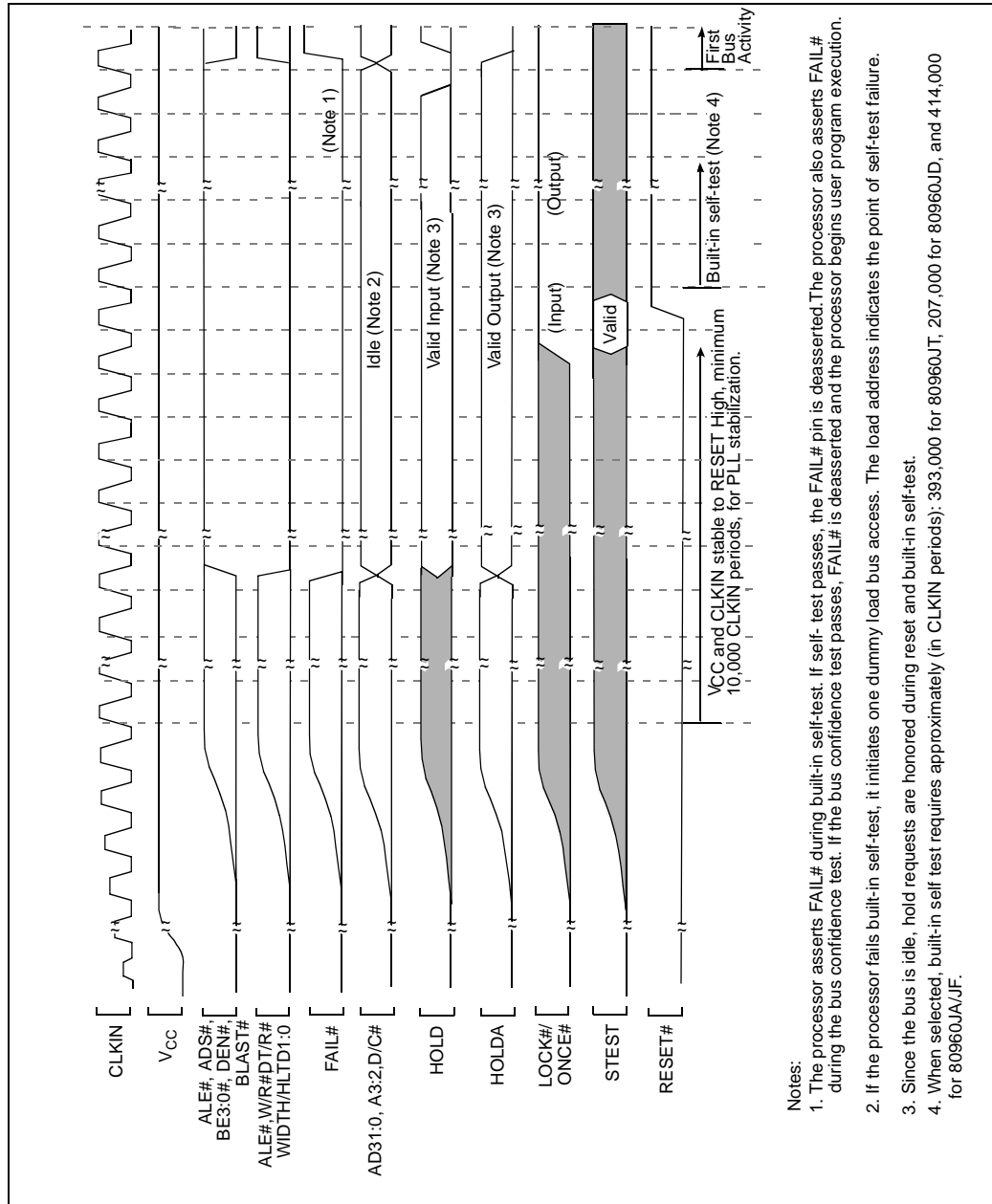

Figure 44. Cold Reset Waveform



- Notes:
1. The processor asserts FAIL# during built-in self-test. If self-test passes, the FAIL# pin is deasserted. The processor also asserts FAIL# during the bus confidence test. If the bus confidence test passes, FAIL# is deasserted and the processor begins user program execution.
 2. If the processor fails built-in self-test, it initiates one dummy load bus access. The load address indicates the point of self-test failure.
 3. Since the bus is idle, hold requests are honored during reset and built-in self-test.
 4. When selected, built-in self test requires approximately (in CLKIN periods): 393,000 for 80960JT, 207,000 for 80960JD, and 414,000 for 80960JA/JF.

Figure 45. Warm Reset Waveform

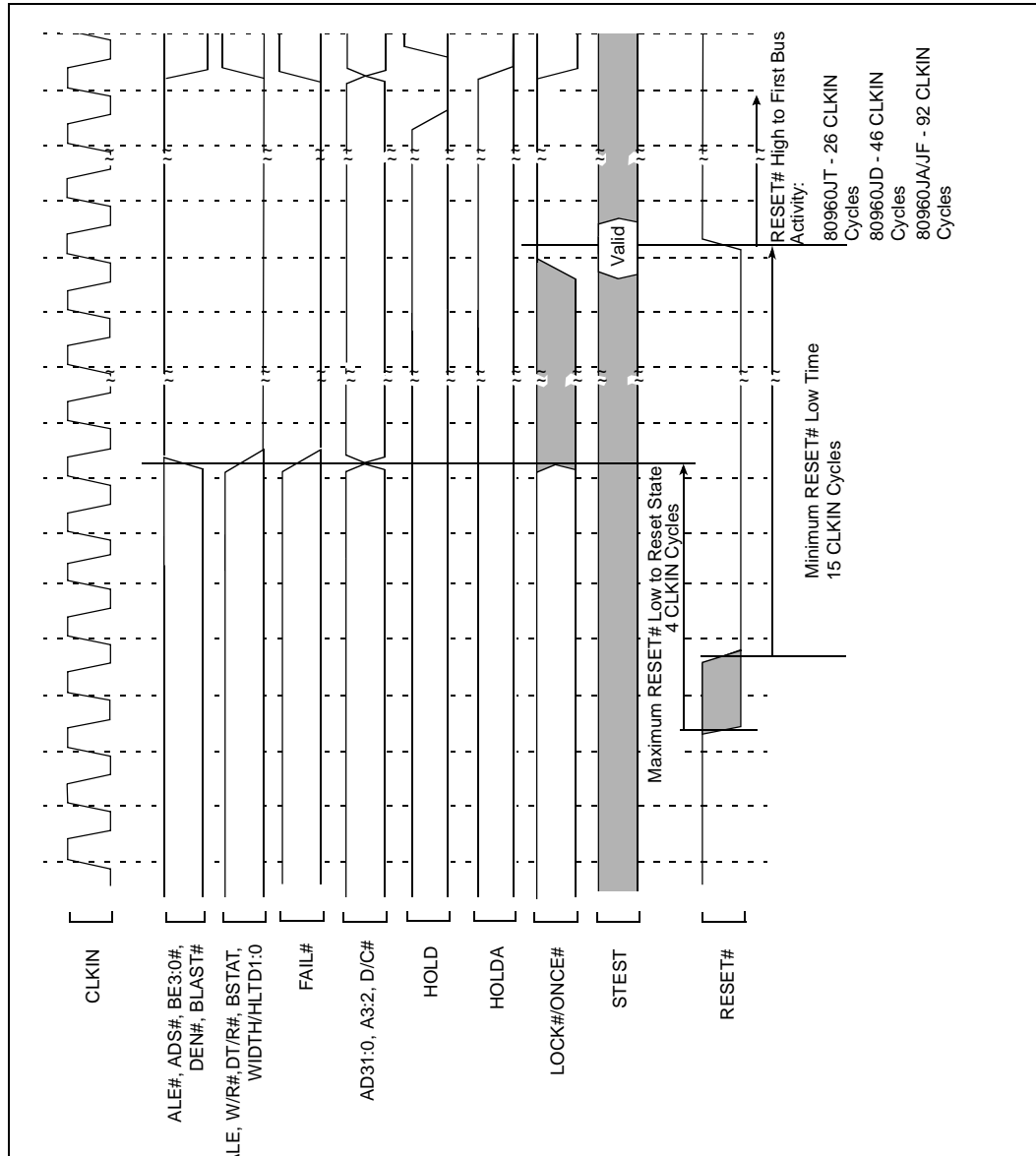
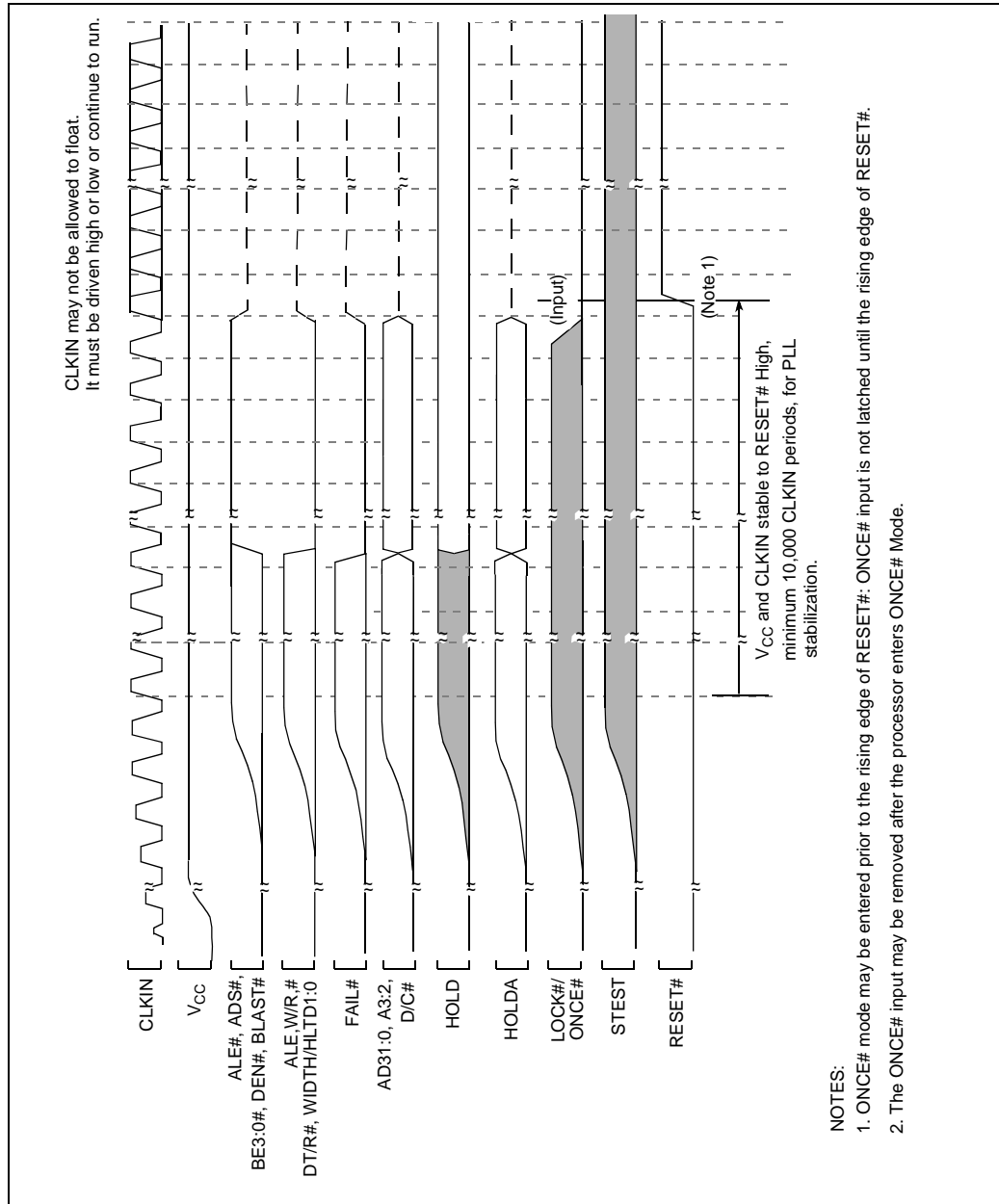

Figure 46. Entering the ONCE State



5.1 Basic Bus States

The bus has five basic bus states: idle (Ti), address (Ta), wait/data (Tw/Td), recovery (Tr), and hold (Th). During system operation, the processor continuously enters and exits different bus states.

The bus occupies the idle (Ti) state when no address/data transactions are in progress and when RESET# is asserted. When the processor needs to initiate a bus access, it enters the Ta state to transmit the address.

Following a Ta state, the bus enters the Tw/Td state to transmit or receive data on the address/data lines. Assertion of the RDYRCV# input signal indicates completion of each transfer. When data is not ready, the processor can wait as long as necessary for the memory or I/O device to respond.

After the data transfer, the bus exits the Tw/Td state and enters the recovery (Tr) state. In the case of a burst transaction, the bus exits the Td state and re-enters the Td/Tw state to transfer the next data word. The processor asserts the BLAST# signal during the last Tw/Td states of an access. Once all data words transfer in a burst access (up to four), the bus enters the Tr state to allow devices on the bus to recover.

The processor remains in the Tr state until RDYRCV# is deasserted. When the recovery state completes, the bus enters the Ti state if no new accesses are required. If an access is pending, the bus enters the Ta state to transmit the new address.

Figure 47. Bus States with Arbitration

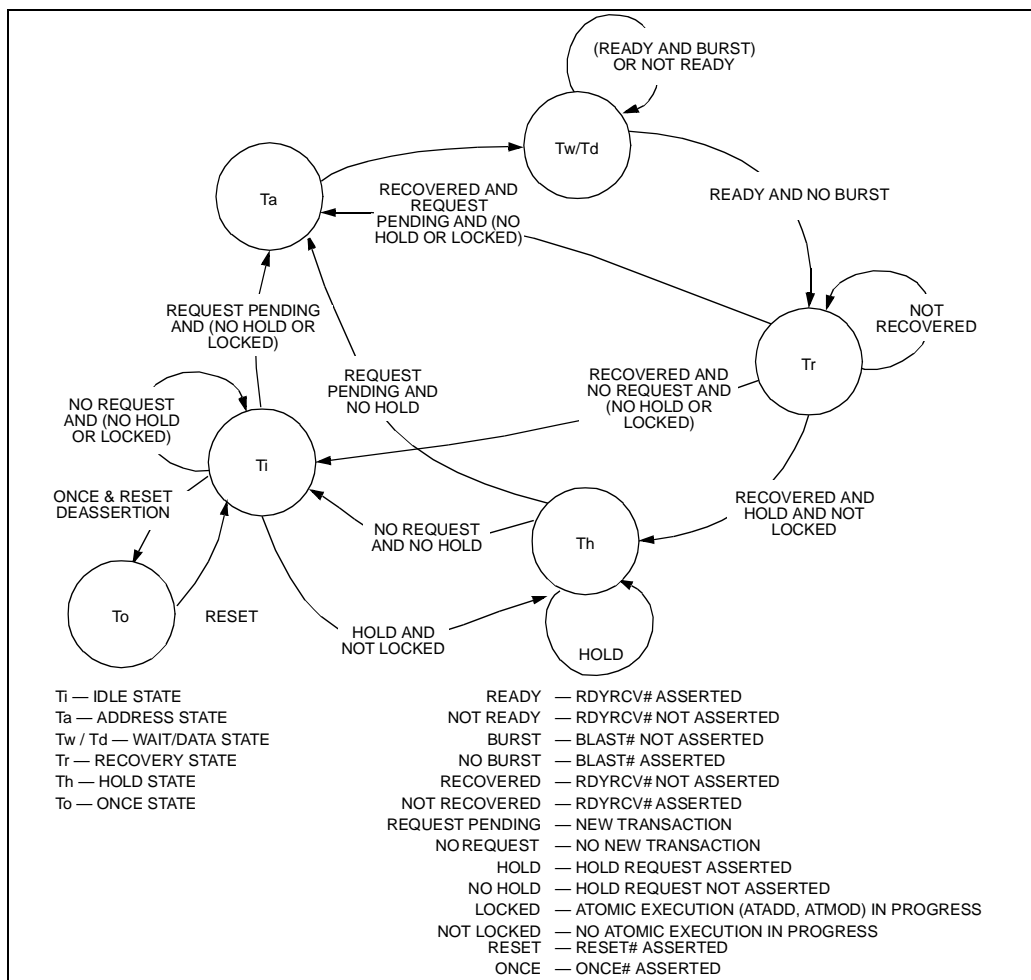

5.2 Boundary-Scan Register

The Boundary-Scan register contains a cell for each pin as well as cells for control of I/O and HIGHZ pins.

Table 25 shows the bit order of the 80960Jx processor Boundary-Scan register. All table cells that contain “CTL” select the direction of bidirectional pins or HIGHZ output pins. If a “1” is loaded into the control cell, the associated pin(s) are HIGHZ or selected as input.

Table 25. Boundary-Scan Register Bit Order

Bit	Signal	Input/ Output	Bit	Signal	Input/ Output	Bit	Signal	Input/ Output
0	RDYRCV# (TDI)	I	24	DEN#	O	48	AD17	I/O
1	HOLD	I	25	HOLDA	O	49	AD16	I/O
2	XINT0#	I	26	ALE	O	50	AD15	I/O
3	XINT1#	I	27	LOCK#/ ONCE# cell	Enable cell ¹	51	AD14	I/O
4	XINT2#	I	28	LOCK#/ ONCE#	I/O	52	AD13	I/O
5	XINT3#	I	29	BSTAT	O	53	AD12	I/O
6	XINT4#	I	30	BE0#	O	54	AD cells	Enable cell ¹
7	XINT5#	I	31	BE1#	O	55	AD11	I/O
8	XINT6#	I	32	BE2#	O	56	AD10	I/O
9	XINT7#	I	33	BE3#	O	57	AD9	I/O
10	NMI#	I	34	AD31	I/O	58	AD8	I/O
11	FAIL#	I	35	AD30	I/O	59	AD7	I/O
12	ALE#	O	36	AD29	I/O	60	AD6	I/O
13	WIDTH/HLTD1	O	37	AD28	I/O	61	AD5	I/O
14	WIDTH/HLTD0	O	38	AD27	I/O	62	AD4	I/O
15	A2	O	39	AD26	I/O	63	AD3	I/O
16	A3	O	40	AD25	I/O	64	AD2	I/O
17	CONTROL1	Enable cell ¹	41	AD24	I/O	65	AD1	I/O
18	CONTROL2	Enable cell ¹	42	AD23	I/O	66	AD0	I/O
19	BLAST#	O	43	AD22	I/O	67	CLKIN	I
20	D/C#	O	44	AD21	I/O	68	RESET#	I
21	ADS#	O	45	AD20	I/O	69	STEST (TDO)	I
22	W/R#	O	46	AD19	I/O			
23	DT/R#	O	47	AD18	I/O			

NOTE:

1. Enable cells are active low.

Table 26. Natural Boundaries for Load and Store Accesses

Data Width	Natural Boundary (Bytes)
Byte	1
Short Word	2
Word	4
Double Word	8
Triple Word	16
Quad Word	16

Table 27. Summary of Byte Load and Store Accesses

Address Offset from Natural Boundary (in Bytes)	Accesses on 8-Bit Bus (WIDTH1:0=00)	Accesses on 16 Bit Bus (WIDTH1:0=01)	Accesses on 32 Bit Bus (WIDTH1:0=10)
+0 (aligned)	• byte access	• byte access	• byte access

Table 28. Summary of Short Word Load and Store Accesses

Address Offset from Natural Boundary (in Bytes)	Accesses on 8-Bit Bus (WIDTH1:0=00)	Accesses on 16 Bit Bus (WIDTH1:0=01)	Accesses on 32 Bit Bus (WIDTH1:0=10)
+0 (aligned)	• burst of 2 bytes	• short-word access	• short-word access
+1	• 2 byte accesses	• 2 byte accesses	• 2 byte accesses

Table 29. Summary of n -Word Load and Store Accesses ($n = 1, 2, 3, 4$)

Address Offset from Natural Boundary in Bytes	Accesses on 8-Bit Bus (WIDTH1:0=00)	Accesses on 16 Bit Bus (WIDTH1:0=01)	Accesses on 32 Bit Bus (WIDTH1:0=10)
+0 (aligned) ($n = 1, 2, 3, 4$)	<ul style="list-style-type: none"> n burst(s) of 4 bytes 	<ul style="list-style-type: none"> case $n=1$: burst of 2 short words case $n=2$: burst of 4 short words case $n=3$: burst of 4 short words burst of 2 short words case $n=4$: 2 bursts of 4 short words 	<ul style="list-style-type: none"> burst of n word(s)
+1 ($n = 1, 2, 3, 4$) +5 ($n = 2, 3, 4$) +9 ($n = 3, 4$) +13 ($n = 3, 4$)	<ul style="list-style-type: none"> byte access burst of 2 bytes $n-1$ burst(s) of 4 bytes byte access 	<ul style="list-style-type: none"> byte access short-word access $n-1$ burst(s) of 2 short words byte access 	<ul style="list-style-type: none"> byte access short-word access $n-1$ word access(es) byte access
+2 ($n = 1, 2, 3, 4$) +6 ($n = 2, 3, 4$) +10 ($n = 3, 4$) +14 ($n = 3, 4$)	<ul style="list-style-type: none"> burst of 2 bytes $n-1$ burst(s) of 4 bytes burst of 2 bytes 	<ul style="list-style-type: none"> short-word access $n-1$ burst(s) of 2 short words short-word access 	<ul style="list-style-type: none"> short-word access $n-1$ word access(es) short-word access
+3 ($n = 1, 2, 3, 4$) +7 ($n = 2, 3, 4$) +11 ($n = 3, 4$) +15 ($n = 3, 4$)	<ul style="list-style-type: none"> byte access $n-1$ burst(s) of 4 bytes burst of 2 bytes byte access 	<ul style="list-style-type: none"> byte access $n-1$ burst(s) of 2 short words short-word access byte access 	<ul style="list-style-type: none"> byte access $n-1$ word access(es) short-word access byte access
+4 ($n = 2, 3, 4$) +8 ($n = 3, 4$) +12 ($n = 3, 4$)	<ul style="list-style-type: none"> n burst(s) of 4 bytes 	<ul style="list-style-type: none"> n burst(s) of 2 short words 	<ul style="list-style-type: none"> n word access(es)

Figure 48. Summary of Aligned and Unaligned Accesses (32-Bit Bus)

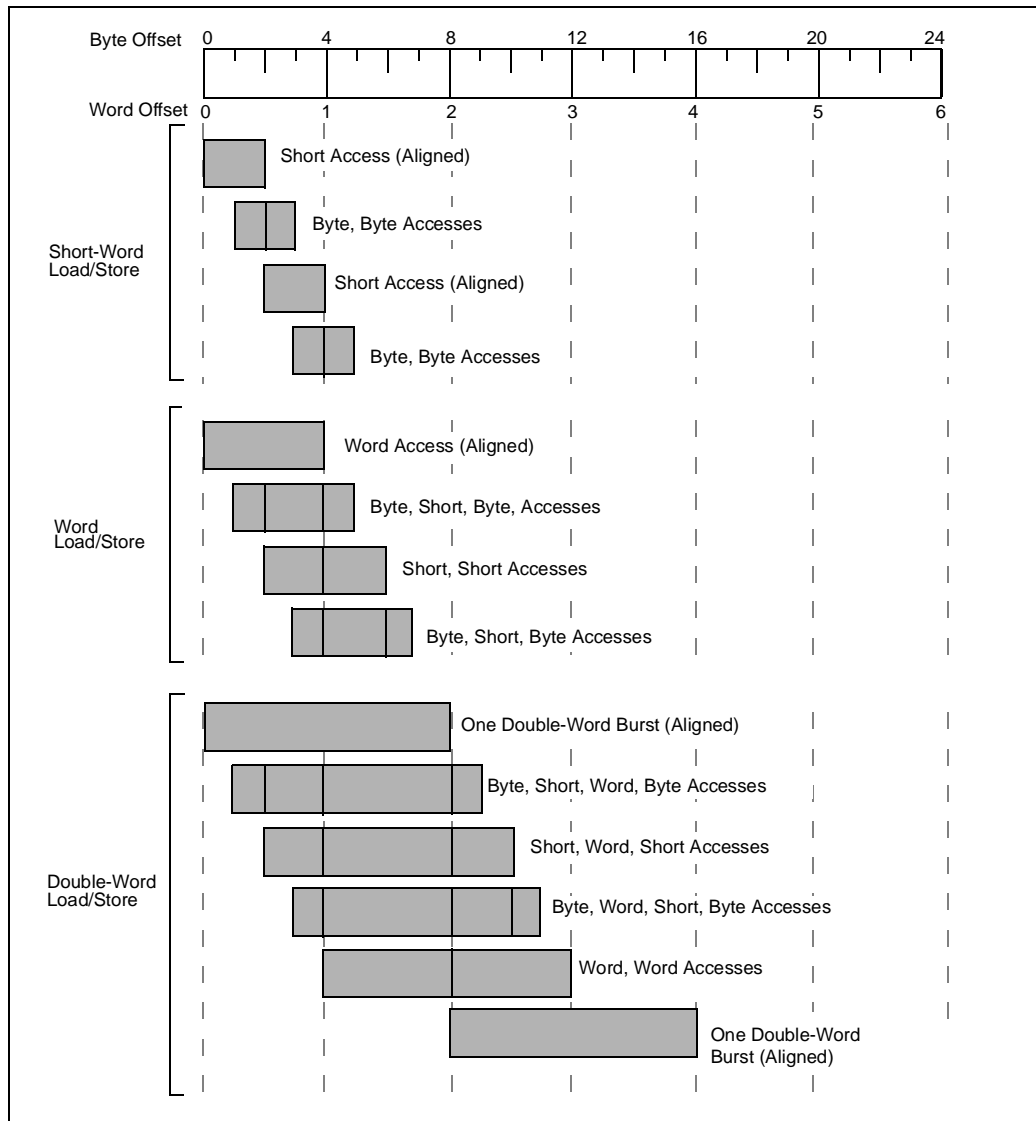
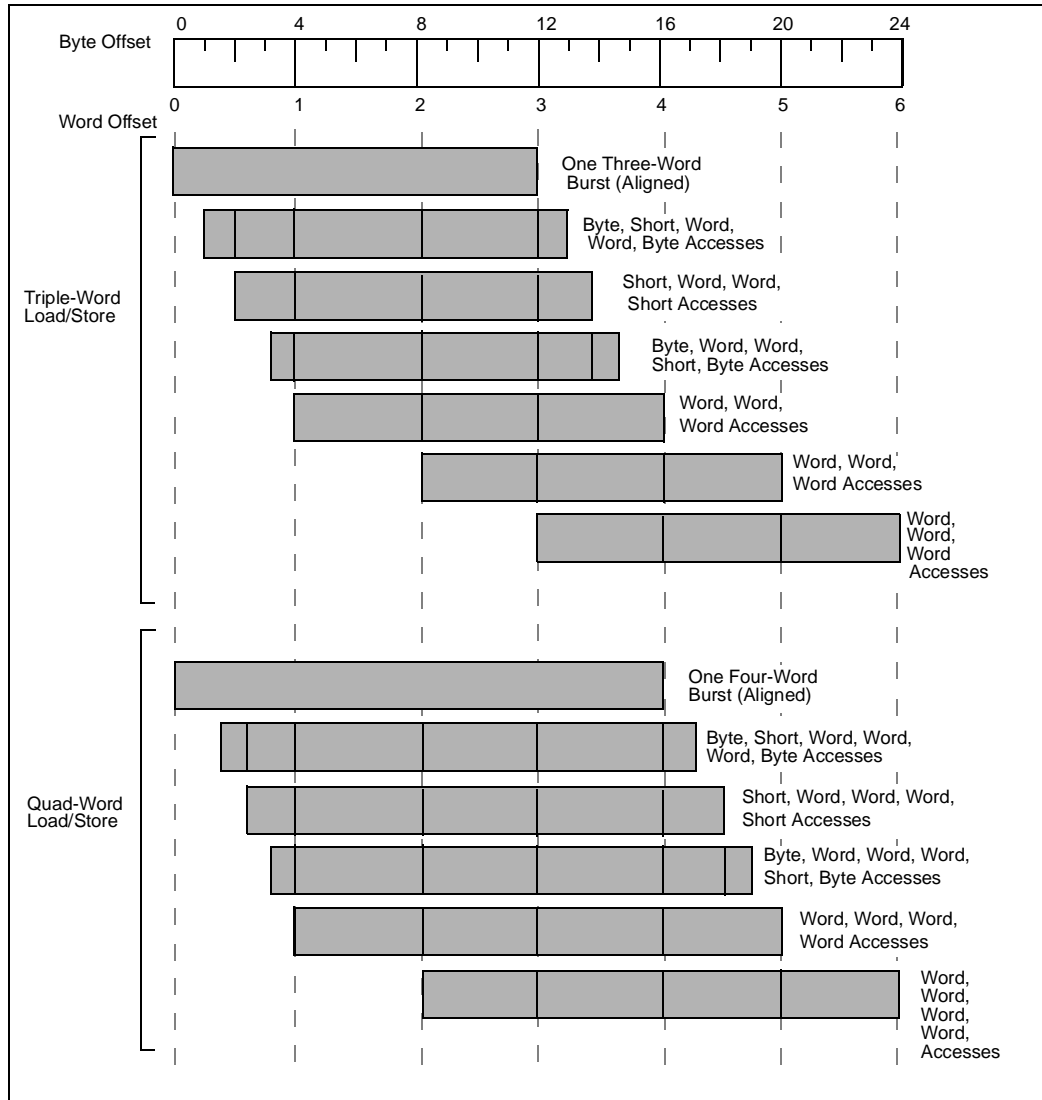

Figure 49. Summary of Aligned and Unaligned Accesses (32-Bit Bus) (Continued)



6.0 Device Identification: 80960Jx 3.3 V Processors

80960Jx processors may be identified electrically, according to device type and stepping (see Figure 50, and Table 31 through Table 36). Table 30 identifies the device type and stepping for all 5 V, 80960Jx processors. Figure 50, and Table 31 through Table 36 identify all 3.3V-5V-tolerant 80960Jx processors. The device ID was enhanced to differentiate between 3.3V and 5V supply voltages, and between non-clock-doubled and clock-doubled cores when stepping from the A2 stepping to the C0 stepping. The 32-bit identifier is accessible in three ways:

- Upon reset, the identifier is placed into the g0 register.
- The identifier may be accessed from supervisor mode at any time by reading the DEVICEID register at address FF008710H.
- The IEEE Standard 1149.1 Test Access Port may select the DEVICE ID register through the IDCODE instruction.
- The device and stepping letter is also printed on the top side of the product package.

Table 30. 80960Jx Device Type and Stepping Reference

Device and Stepping	Version Number	Part Number	Manufacturer	X	Complete ID (Hex)
80960JT A0, A1	0000	0000 1000 0010 1011	0000 0001 001	1	0082B013
80960JD C0	0011	0000 1000 0011 0000	0000 0001 001	1	30830013
80960JF C0	0011	0000 1000 0010 0000	0000 0001 001	1	30820013
80960JA C0	0011	0000 1000 0010 0001	0000 0001 001	1	30821013

Figure 50. 80960JT Device Identification Register

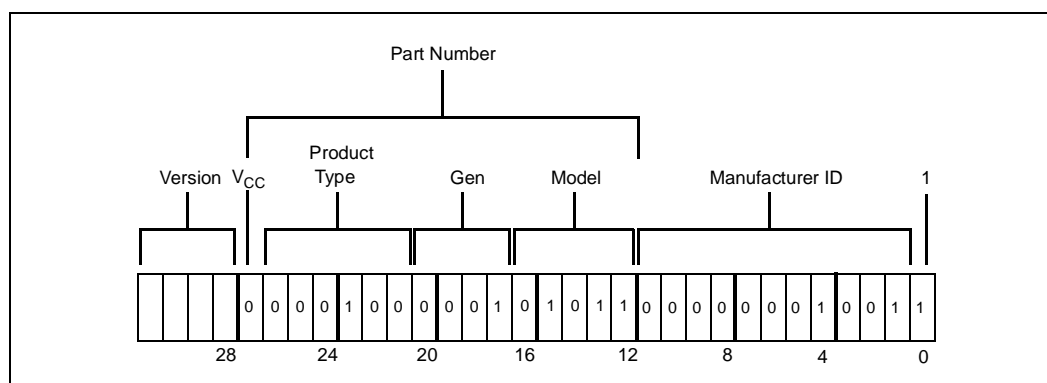

Table 31. Fields of 80960JT Device ID

Field	Value	Definition
Version	See Table 32	Indicates major stepping changes.
V _{CC}	0 = 3.3 V device	Indicates that a device is 3.3 V.
Product Type	000 100 (Indicates i960 CPU)	Designates type of product.
Generation Type	0001 = J-series	Indicates the generation (or series) the product belongs to.
Model	D DPCC D = Clock Multiplier (01) Clock-Tripled (P) Product Derivative (0) Jx C = Cache Size (11) 16K I-cache, 4K D-cache	Indicates member within a series and specific model information.
Manufacturer ID	000 0000 1001 (Indicates Intel)	Manufacturer ID assigned by IEEE.

Table 32. 80960JT Device ID Model Types

Device	Version	V _{CC}	Product	Gen.	Model	Manufacturer ID	'1'
80960JT A0, A1	0000	0	000100	0001	01011	00000001001	1

Figure 51. 80960JD Device Identification Register

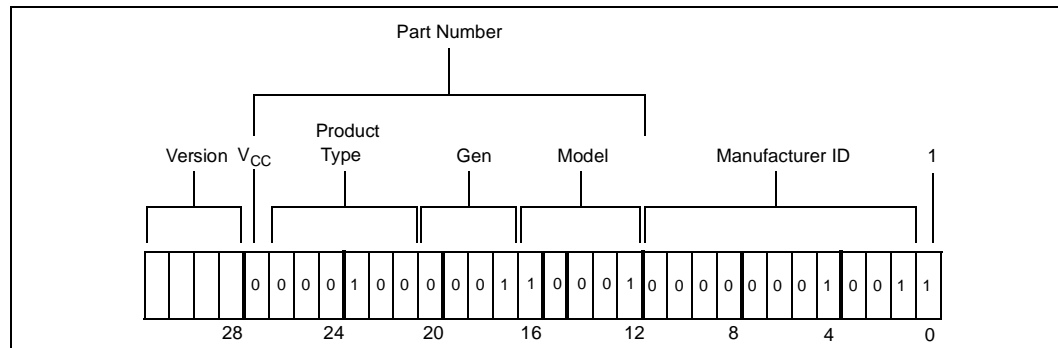

Table 33. Fields of 80960JD Device ID

Field	Value	Definition
Version	See Table 30	Indicates major stepping changes.
V _{CC}	0 = 3.3 V device 1 = 5V device	Indicates that a device is 3.3 V.
Product Type	00 0100 (Indicates i960 CPU)	Designates type of product.
Generation Type	0001 = J-series	Indicates the generation (or series) the product belongs to.
Model	D000C D = Clock Doubled (0) Not Clock-Doubled (1) Clock Doubled C = Cache Size (0) 4K 1-cache, 2K D-cache (1) 2K 1-cache, 1K D-cache	Indicates member within a series and specific model information.
Manufacturer ID	000 0000 1001 (Indicates Intel)	Manufacturer ID assigned by IEEE.

Table 34. 80960JD Device ID Model Types

Device	Version	V _{CC}	Product	Gen.	Model	Manufacturer ID	'1'
80960JD C0	0011	0	000100	0001	10000	00000001001	1

Figure 52. 80960JA/JF Device Identification Register

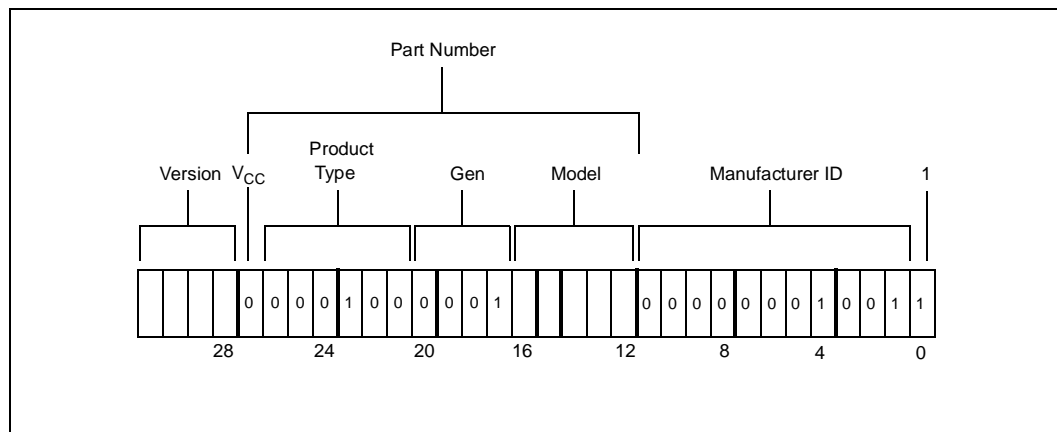

Table 35. Fields of 80960JA/JF Device ID

Field	Value	Definition
Version	See Table 36	Indicates major stepping changes.
V _{CC}	0 = 3.3 V device 1 = 5V device	Indicates that a device is 3.3 V.
Product Type	00 0100 (Indicates i960 CPU)	Designates type of product.
Generation Type	0001 = J-series	Indicates the generation (or series) to which the product belongs.
Model	0000C C = Cache Size 0 = 4K I-cache, 2K D-cache 1 = 2K I-cache, 1K D-cache	Indicates member within a series and specific model information.
Manufacturer ID	000 0000 1001 (Indicates Intel)	Manufacturer ID assigned by IEEE.

Table 36. 80960JA/JF Device ID Model Types

Device	Version	V _{CC}	Product	Gen.	Model	Manufacturer ID	'1'
80960JA C0	0011	0	000100	0001	00001	00000001001	1
80960JF C0	0011	0	000100	0001	00000	00000001001	1

7.0 Revision History

Table 37. Data Sheet Revision History

Revision	Date	Description
002	12/98	Corrected orientation of MPBGA package diagrams (Figures 6 and 7). Added Figures 11, 12, 14, and 15 to distinguish 80960JT 3.3-V and 5-V signal derating curves from the 80960JA/JF/JD derating curves.
001	03/98	This datasheet supersedes revisions to the following 80960Jx datasheets: #273109 (JT), #272971-002 (JD), and #276146-001 (JA/JF). In addition to combining the documents into one, the following content was changed: Figure 1 "80960Jx Microprocessor Package Options" on page 7: Added MPBGA package diagram Merged 80960JA/JF/JD/JT 3.3 volt Processor data sheets Section 3.1.4, "80960Jx 196-Ball MPBGA Pinout" on page 29: Added new Figures 6 and 7, Tables 10, 11 and 13 Figure 16 " T_{LX} vs. AD Bus Load Capacitance – 80960JA/JF/JD Processors" on page 49: Added with the note that follows the figure.