

# Am186™CC Microcontroller Power Management Circuit



## Application Note

by Gino Davis and Douglas Paulson

*This application note describes the power use, design considerations, and functions of the Am186™CC microcontroller power management circuit (PMC).*

## INTRODUCTION

Devices that operate efficiently at high speeds and low voltages are essential for producing successful products. This is achieved by innovative designs, improved fab processes, better materials, and power management. Power management plays an important role in the power efficiency of a device to help it meet stringent system power requirements and increased mobile power supply longevity. Therefore, the Am186CC™ microcontroller is combined with a power management circuit capable of providing substantial power savings.

The Am186CC microcontroller power management circuit (PMC) is modeled from and integrates the system management principles of power supervision, compliance (to the standard to which you are designing), and efficiency. Supervising power and its requirements and assuring power is being used in the most efficient way are simple and effective methods of power management design.

Because the CPU's power use is directly related to the frequency at which the CPU is running, managing the operating frequency of the CPU is a major consideration in power consumption management. The stage or present task required by the CPU determines at which frequency the CPU runs to perform its task efficiently and effectively. Ensuring that devices not in use are shut down or in power-saving mode and configuring PIOs to their most power-efficient state are essential to power management. Software also plays an important part in power management.

The core of the design can be used for a variety of specifications. For the purpose of example and reference, we emulated the Am186CC microcontroller PMC used in an ISDN TA with a telephone hand set. This application includes three different power requirements:

- A normal power-consuming stage occurs when power to the ISDN TA is available at the remote location (the house or business where the phone is

located), in which there is no real power-saving requirement.

- A medium power-saving stage occurs when there is no power available from the terminal adapter (TA) remote location, and a call is being placed or received. In this medium power stage, the ISDN TA receives 450 mW of power from its central office.
- A low-power stage occurs when no power is available from the ISDN TA remote location, and no call is being attempted or received. In this case, the ISDN TA only receives 25 mW of power from its central office, entering a very low power-saving mode.

Figure 1 and Figure 2 on page 2 illustrate the contents of the design. The power to the ISDN TA is monitored by the Frequency Select block using simple logic and software. The power is also used to determine when the Am186CC microcontroller is reset and to configure the PLL of the Am186CC microcontroller. The HOOK signal and the receiver ON-HOOK/OFF-HOOK switch is also monitored by the Frequency Select block for determining the appropriate frequency for the different stages. The Pulse Control block ensures that the Am186CC microcontroller does not receive any short or runt pulses while switching frequencies on the fly in the PLL Bypass mode. In addition, the Frequency Output Control block ensures that only one frequency outputs to the Am186CC microcontroller.

Although there are other methods of providing the various frequencies to the CPU, this design uses three different oscillators with different frequency speeds to accommodate the application requirements. Also, the switches for the POWERGOOD and HOOK SW circuit shown in Figure 3 on page 3 are used for simulating inputs to the circuit, and the switches are not needed for functionality of the circuit.

Figure 3 on page 3 and Table 1 on page 4 describe the Am186CC microcontroller signals used by the application node.

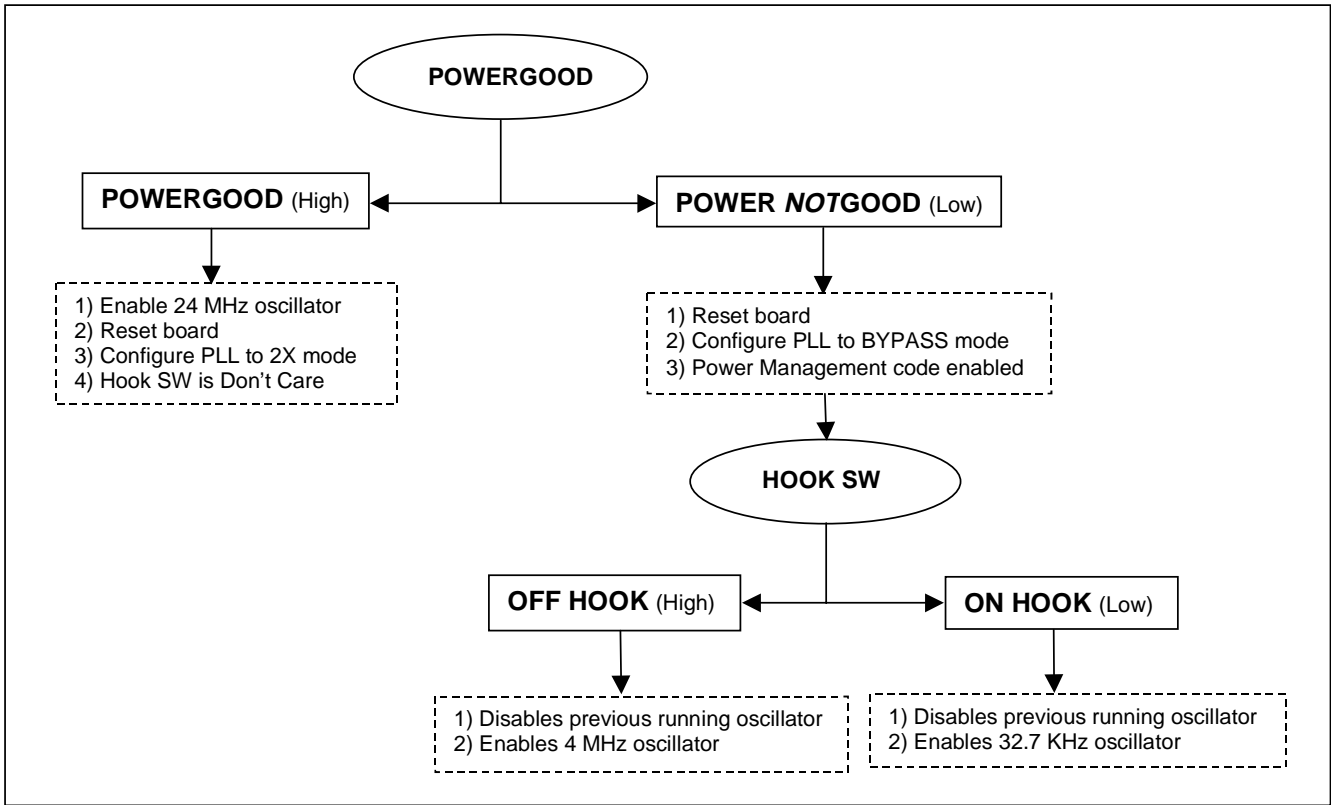

**Figure 1. System Power Management Clocking/Timing Flow Chart**

POWERGOOD – Functions as main power to the terminal adapter (TA):

- **POWERGOOD** (logic level High): Power is available at the TA remote location.
- **POWER NOTGOOD** (logic level Low): Power is not available at the TA remote location, functioning as a power failure.

HOOK SW – Functions as a receiver on the TA being off or on hook:

- **ON HOOK** (logic level Low): No outgoing or incoming call is being attempted.
- **OFF HOOK** (logic level High): Either an outgoing or incoming call is being attempted.

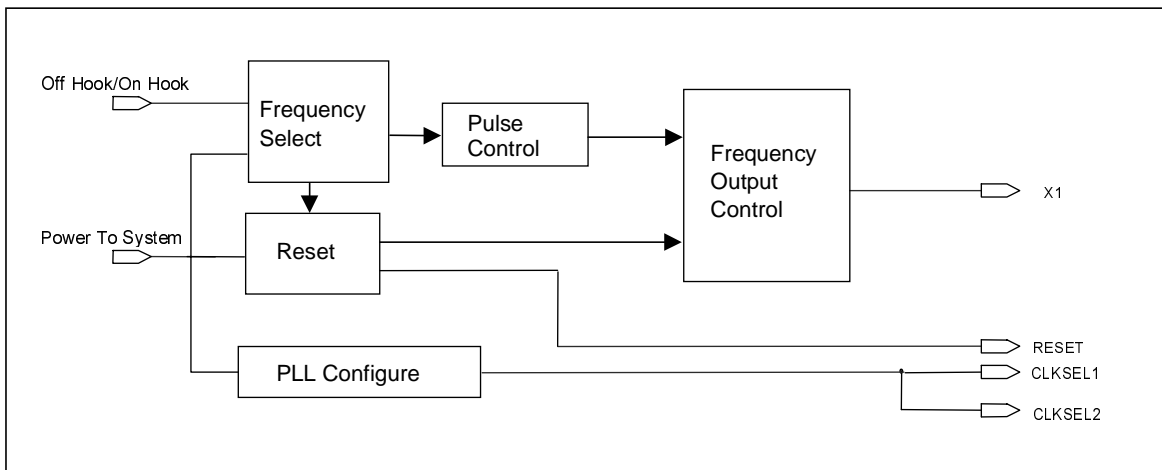

**Figure 2. Power Management Circuit Block Diagram**

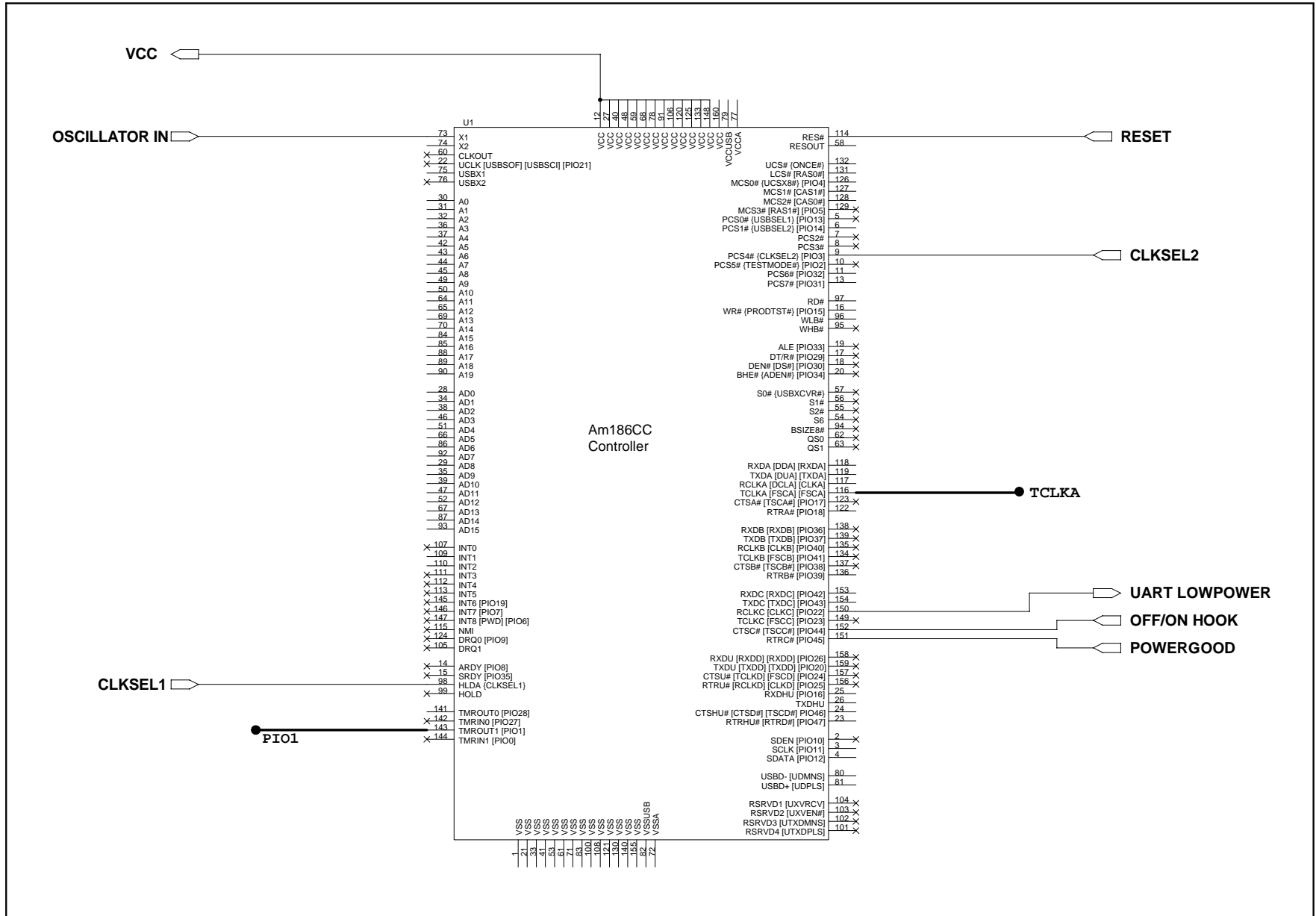

Figure 3. Am186CC Microcontroller Signals Used With Power Management Circuit

**Table 1. Signal Descriptions**

Signal	Description
Configure PLL (CLKSEL1, CLKSEL2)	The two pins are used to configure the PLL to its various modes. The PLL can also be configured to 4x and 1x modes, but the 4x and 1x modes are not applicable in this reference. <ul style="list-style-type: none"> <li>When CLKSEL1 and CLKSEL2 are both Low, the PLL is configured to Bypass mode.</li> <li>When CLKSEL1 and CLKSEL2 are both High, the PLL is configured to 2x mode.</li> </ul> For more information about CLKSEL1 and CLKSEL2, refer to the <i>Am186™CC/CH/CU Microcontrollers User's Manual</i> , order #21914B.
HOOK SW	Functions as a telephone receiver that is on or off the hook.
OSCILLATOR IN	Inputs one of three oscillator frequencies from the power management circuit to the Am186CC microcontroller.
POWERGOOD	Functions as main power to the TA.
RESET	Resets the Am186CC microcontroller when the POWERGOOD signal is initiated to either the POWERGOOD or POWER NOTGOOD state.
TCLKA	Drives the HDLC transmitter and is connected to and controlled by PIO1.
UART LOWPOWER	PIO22 is used to put the UART's transceiver into shutdown mode when in the power managed state.
VCC	Power is supplied to the TA at its remote location; general power to the entire application.

## CIRCUIT OPERATION

This section provides a more detailed description of how the circuit operates. Although this reference is designed for a TA application with three separate power requirement modes, the core of the design can be applied to a wide range of applications. Figure 4 on page 6 shows the sections of the Am186CC PMC schematics. Figure 5 on page 7 shows the entire Am186CC PMC schematics without boxes around each section.

### Frequency Select

- When NOR-pwrgood gate inputs are High:
  - 4-MHz and 32-KHz enabling flip-flops are cleared, disabling the 4-MHz and 32-KHz oscillator regardless of the HOOK SW position.
  - Enabling the active High 24-MHz oscillator and driving a Low signal to input 1 of the NOR 24-MHz gate outputs the 24-MHz frequency to X1.
- When NOR-pwrgood gate inputs are Low:
  - 24-MHz oscillator is disabled.
  - 4-MHz and 32-KHz flip-flops are active and frequency selection is determined by the input to the respective AND gate, which comes from the HOOK SW position.
  - When OFF HOOK:

Input 1 to the AND-onhk gate is Low, disabling the 4-MHz oscillator.

Inputs 1 and 2 to AND-offhk are High, which enables the 32-KHz oscillator and sends a Low signal to the NOR-32-KHz gate, which outputs the 32-KHz frequency to X1.

- When ON HOOK:

Input 1 to the AND-offhk gate is Low, disabling the 32-KHz oscillator.

Inputs 1 and 2 to the AND-onhk gate are High, which enables the 4-MHz oscillator and sends a Low signal to NOR-4-MHz gate, which outputs a 4-MHz frequency to X1.

### Pulse Safety

The PMC design requires changing between 4-MHz and 32-KHz frequencies on the fly (without resetting the processor). The two flip-flops in series ensure that when alternating from 4-MHz to 32-KHz frequencies, the Am186CC microcontroller continues to receive full pulses. When alternating from 32-KHz to 4-MHz frequencies, short pulses are not a major concern because the 32-KHz frequency periods are long. The Am186CC microcontroller must be in the PLL Bypass mode when alternating between frequencies. The Am186CC microcontroller must receive a full pulse signal; short or runt pulses violate the Am186CC microcontroller timing specification.

## Frequency Output Control

Three NOR gates control the frequency output to X1. Whenever input 1 to NOR-32-KHz, NOR-4-MHz, or NOR-24-MHz is Low, the respective gate outputs the frequency on its input pin 2. Two or more of these NOR gates never have a Low signal on pin 1 at the same time.

- 24-MHz Output: When pin 1 of the NOR-24-MHz gate is Low, the 24-MHz frequency is driven on pin 2 of this gate, outputting this frequency to pin 2 of the XOR-out gate. Meanwhile, the NOR-4-MHz and 32-KHz gates are driving out High signals to both the XOR-in gate pins, which in turn drives out a Low signal to pin 1 of XOR-out. With pin 1 of the XOR-out gate low, the XOR-out gate outputs the frequency generated on its pin 2 to X1.
- 4-MHz Output: When pin 1 of the NOR-4MHz gate is Low, the 4-MHz frequency is being driven on pin 2 of this gate, outputting this frequency to pin 1 of the XOR-in gate. Meanwhile, the NOR-32-KHz gate is driving out a Low signal to pin 2 of the XOR-in gate. With pin 2 of the XOR-in gate Low, the frequency generated on pin 1 is outputted to input pin 1 of the XOR-out gate while the NOR-24 MHz gate is driving a Low signal to pin 2 the of XOR-out gate. With pin 2 of the XOR-out gate Low, the XOR-out gate outputs the frequency generated on its input pin 1 to X1.

- 32-KHz Output: When pin 1 of the NOR-32-KHz gate is Low, the 32-KHz frequency is being driven on pin 2 of this gate, outputting this frequency to pin 2 of the XOR-in gate. Meanwhile, the NOR-4-MHz gate is driving out a Low signal to pin 1 of the XOR-in gate. With pin 1 of the XOR-in gate Low, the frequency being generated on pin 2 is being outputted to input pin 1 of the XOR-out gate while the NOR-24-MHz gate is driving a Low signal to pin 2 the of XOR-out gate. With pin 2 of the XOR-out gate Low, the XOR-out gate outputs the frequency generated on its input pin 1 to X1.

## Reset

XOR-reset is used for generating a reset to the Am186CC microcontroller with the initiation of a POWERGOOD or a POWER *NOT*GOOD signal.

AND-reset is used for an initial board power-up reset.

## PLL Configuration

These two outputs are connected to HLDA(CLKSEL1) and PCS4(CLKSEL2) of the Am186CC microcontroller to configure the PLL to 2x mode when the signal is POWERGOOD, or to PLL Bypass mode when the signal is POWER *NOT*GOOD.

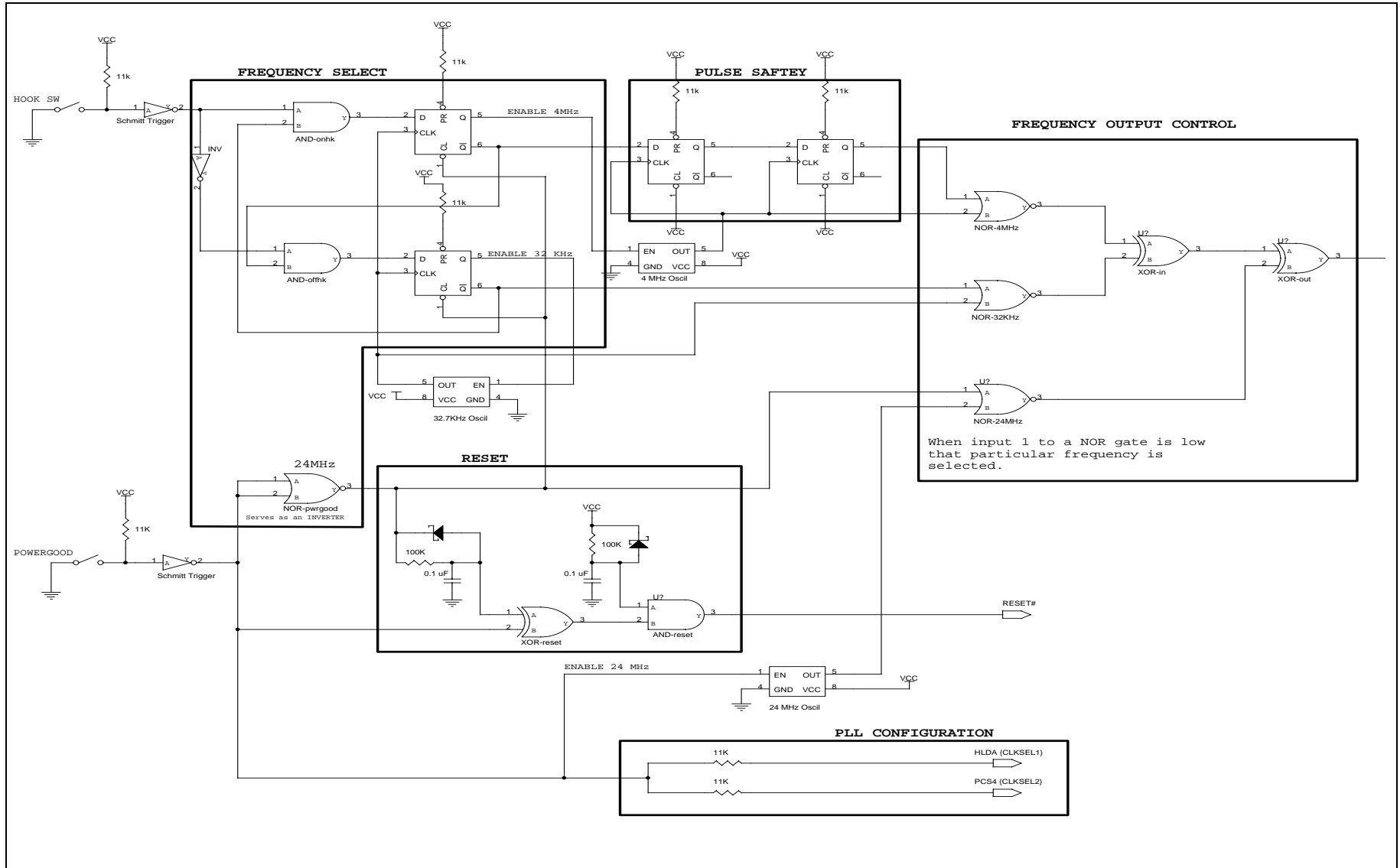

Figure 4. Power Management Circuit Schematic In Sections

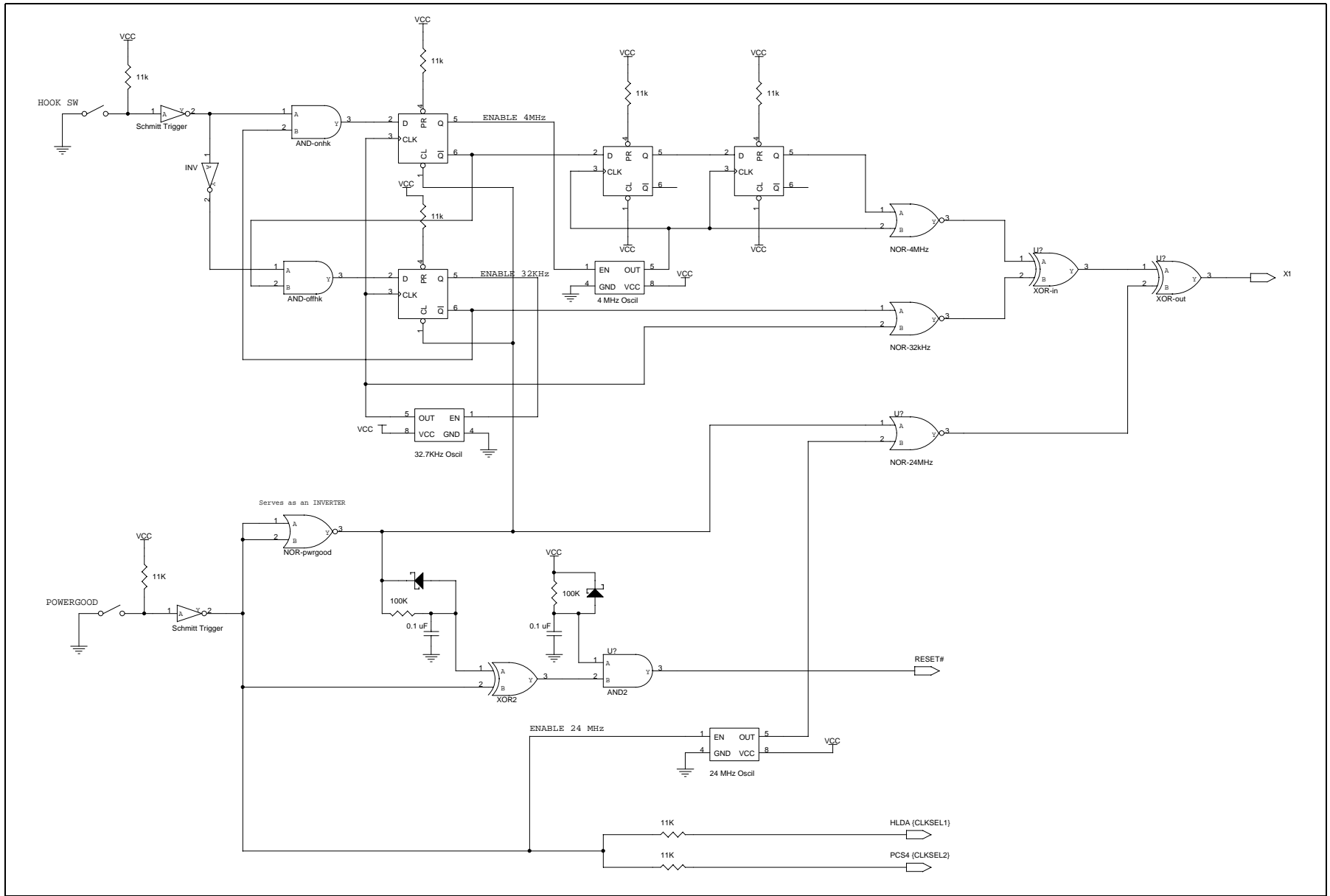

Figure 5. Power Management Circuit Schematic

## MEASUREMENTS

### Test Conditions

The PMC is tested with an Am186CC microcontroller reference design ISDN TA board. All devices not applicable to the test were removed from the board, leaving the CPU, DRAM, Flash memory, and a UART for loading code. Because the board is not designed with power management in mind, it utilizes +5-V DRAM and Flash memory devices, even though the Am186CC microcontroller is a 3.3-V device. The ISDN TA board uses 5-V memory devices with a 3.3-V microcontroller to accommodate the S/T controller for the ISDN TA applications. Anyone interested in designing a power management system and/or application with the Am186CC microcontroller should use CMOS 3.3-V memory to utilize power more efficiently. Although the ISDN TA board is not designed for this particular application, it provides a platform for demonstrating and testing the PMC.

### General Power Measurements

It is important to note that all of the power measurements derived from these test conditions and documented in this application note show what to expect when following the guidelines described in this document. However, you can obtain better power

efficiency than that described in this application note by using better power-efficient parts and practicing good programming methodology.

Table 2 contains a sample of a test measurements taken under various conditions to establish expected baseline current draw values.

#### Power Measurement Descriptions

<b>VCC</b>	Am186CC microcontroller digital current draw
<b>VCCA</b>	Am186CC microcontroller analog current draw
<b>DRAM</b>	+5-V high-performance CMOS dynamic RAM
<b>FLASH</b>	+5-V CMOS Flash memory
<b>TRANS</b>	+5-V RS232 transceiver
<b>OTHER</b>	Other parts on the board such as the system crystal and the 3.3-V LDO that collectively consume measurable current draw
<b>PM CIR</b>	The total current draw of the PMC (in Table 3 only)
<b>TOTAL</b>	The total current draw of the entire board

**Table 2. General Power Measurements**

CODE	CPU SPEED	VCC	VCCA	DRAM	FLASH	TRANS	OTHER	TOTAL
1	48 MHz	119	5.2	1.5	22.1	19.75	12.45	180.3
2	48 MHz	115.2	4.6	88.1	–	10.7uA	12.5	220.6
3	48 MHz	116.1	4.45	87.3	–	18.65	11.8	238.3

**Note:** All values are in mA unless otherwise specified.

Row 1 contains measurements taken with code that is designed to keep the CPU busy, simulating maximum use of the Am186CC microcontroller. All four HDLC channels are in loopback at 1/8 clock speed. All three timers are running: one timer drives the TCLK pin of all four HDLC channels; the two other timers are in a continuous loop, but their outputs are not driving any PIO pins. The High Speed UART is continuously busy while all unused PIOs are set up as inputs. The code is written in assembly language and is designed to run from Flash memory, and not DRAM. Although the VCC in row 1 in Table 2 is the highest value of the three VCC values, the TOTAL value in row 1 is the lowest value of the three TOTAL values. This condition is caused by running the code from the Flash instead of the DRAM, which saves power.

Row 2 contains code that puts the UART transceiver in Shutdown mode, runs four HDLCs, uses one timer to drive the HDLCs' transmit clock, and runs one timer

constantly while the third timer is off. The code also accesses the S/T interface and synchronous serial interface (SSI) to simulate a terminal adapter application. This version of code is written in C language and runs out of DRAM, which shows a significant increase in total system power draw even though nearly 20 mA is eliminated by putting the UART transceiver in Shutdown mode. This condition is caused by the DRAM's increased power consumption, which is caused by the code language and the typical requirement that DRAM needs to be constantly refreshed.

The code in Row 3 is identical to the code in Row 2 except the UART transceiver is not put in Shutdown mode, and only two HDLCs are running. The total increase in total-system current draw reflects the UART transceiver running and indicates that the HDLCs do not draw a significant amount of current.



## Power Management Measurements

Table 3 contains the power measurement values taken with the PMC attached to the Am186CC and using code that monitors the power input to the system and manages the power consumption according to the different stage needs.

The system running at 48 MHz indicates that full power is being supplied to the simulated TA; therefore, no power management is required. The total current consumption is higher than the total current consumption of the Code 3 values in Table 1 because of the additional current draw of the PMC.

The system running at 4 MHz indicates that the TA is not receiving power from the remote location and is receiving limited power from the phone company through the phone line for an incoming or outgoing call. This causes the PMC to enable the 4-MHz oscillator. This triggers the PM code, disabling address multiplexing on the data bus, putting the UART transceiver in Shutdown mode, configuring unused PIOs as high-impedance inputs, and transmitting the HDLC in low power mode.

The 32.7-KHz measurements result from no power being supplied from the remote location and no incoming or outgoing call being attempted. The PMC enables the 32.7-KHz oscillator and the PM code. Then the PMC puts the Am186CC microcontroller in Halt mode and periodically brings the microcontroller out of Halt mode to check for incoming or outgoing calls. The fluctuating current in DRAM is caused by the CPU going in and out of Halt mode, thus having fluctuating current in the TOTAL measurement. Although not evident, the VCC current also varies, but in the  $\mu\text{A}$  range, which is not apparent in the VCC measurement.

Typical  $I_{\text{CC}}$  currents, being very low, are measured to be approximately 2.5–3.0  $\mu\text{A}/\text{MHz}$ . This low  $I_{\text{CC}}$  rate not only enables low-power consumption but also contributes to a low EMI signature. This current rate is

based on measurements taken under the test conditions described in Table 3. The current rate is a typical representation of what customers can see in their application designs.

**NOTE:** This measurement only applies when the microcontroller is run at higher frequencies (e.g., 4-MHz and above). At lower frequencies, this measurement tends to increase due to an  $I_{\text{CC}}$  constant that is always present but less apparent at higher frequencies.

### POWER MANAGEMENT KEY POINTS

Although the PMC is designed for a simulated TA application with three different power requirements, the circuit is easily tailored for other specifications and/or applications. For example, if your application only required two different power modes utilizing a 25-MHz frequency at 2x PLL mode and a 12-MHz frequency in PLL Bypass mode, the following are some of the major PMC modifications for these specifications:

- Replace the 24-MHz oscillator with the 25-MHz crystal.
- Remove the AND-offhk, the 32-KHz enable flip-flop, the 32-KHz oscillator, and the NOR-32-KHz gate.
- Remove the two Pulse Safety flip-flops. This is optional. Because the frequency is not switched on the fly, the two Pulse Safety flip-flops are not required.
- Replace the 4-MHz oscillator with the 12-MHz oscillator.
- Tie the Q output of the 12-MHz flip-flop to the A input of the NOR-4-MHz gate, which is now called the NOR-12-MHz gate.
- Remove the XOR-in gate and tie the output of NOR-12-MHz gate to the A input of XOR-out gate.

**Table 3. Power Management Measurements**

CPU SPEED	VCC	VCCA	DRAM	FLASH	TRANS	PM CIR	OTHER	TOTAL
48 MHz	117	5.4	87	–	18.7	17	12.4	257.5
4 MHz	11.6	0.7	12.6	–	12 $\mu\text{A}$	8.2	1.4	34.5
32.7 KHz	1.75	0.13	0.4 - 1.1	–	12 $\mu\text{A}$	1.8	0.1 - 1	4 - 6

**Notes:**

1. All values are in mA unless otherwise specified.
2. The code for generating the measurements in this table can be found in the Am186™CC Microcontroller Power Management CodeKit Software, V1.0, May 18, 1999.

Again, this is just an example of how the circuit can be made to accommodate different system requirements. Proper termination of unused PIO pins are important in achieving low power. Because most PIOs have alternate functions and some have either internal pullups, internal pulldowns, or Schmitt Trigger Inputs, it is important to consult the *Am186™CC/CH/CU Microcontroller User's Manual* (order #21914) for proper termination of unused PIOs.

Running your code from the most efficient memory possible is also a contributing factor to power management. As indicated by the measurements in Table 1, the TOTAL measurement is low (although Row 1 shows the VCC is drawing more current, indicating that the CPU is working harder) because the code is being executed out of Flash memory, which is the more efficient memory in this case.

When there is no activity in the system, executing the HALT command (which puts the system in Halt mode) is recommended. Depending on the particular system design, putting the processor in Halt mode can save the total system power as much as 20%.

## SUMMARY

Power managing the Am186CC microcontroller depends largely on managing the system speed (frequency) as efficiently as possible. The PMC is designed to handle most of this for you by monitoring key signals and switching to the appropriate frequency when needed. Software plays a key role in managing the Am186CC microcontroller by monitoring the frequency at which the system is running to determine when to take additional power-saving measures, such as configuring the PIOs, putting peripheral devices in Low or Shutdown mode, and even putting the Am186CC microcontroller in Halt mode when necessary.

The PMC, combined with good software methodology, provides good power management for the Am186CC microcontroller, enabling it to meet many stringent power requirements.

### Trademarks

AMD, the AMD logo, and combinations thereof, and Am186 are trademarks of Advanced Micro Devices, Inc.

Other product names used in this publication are for identification purposes only and may be trademarks of their respective companies.

### Disclaimer

The contents of this document are provided in connection with Advanced Micro Devices, Inc. ("AMD") products. AMD makes no representations or warranties with respect to the accuracy or completeness of the contents of this publication and reserves the right to make changes to specifications and product descriptions at any time without notice. No license, whether express, implied, arising by estoppel or otherwise, to any intellectual property rights is granted by this publication. Except as set forth in AMD's Standard Terms and Conditions of Sale, AMD assumes no liability whatsoever, and disclaims any express or implied warranty, relating to its products including, but not limited to, the implied warranty of merchantability, fitness for a particular purpose, or infringement of any intellectual property right.

AMD's products are not designed, intended, authorized or warranted for use as components in systems intended for surgical implant into the body, or in other applications intended to support or sustain life, or in any other application in which the failure of AMD's product could create a situation where personal injury, death, or severe property or environmental damage may occur. AMD reserves the right to discontinue or make changes to its products at any time without notice.