

AFBR-5718APZ

Small Form-Factor Pluggable Optical Transceiver for Gigabit Ethernet (1.25 Gbd)

Description

The Broadcom[®] AFBR-5718APZ optical transceiver is compliant with the specifications set forth in both the IEEE802.3 (1000BASE-SX), and the small form-factor pluggable (SFP) multisource agreement (MSA). Its primary application is servicing Gigabit Ethernet links between optical networking equipment. It offers system cost, upgrade, and reliability benefits by virtue of being hot-pluggable. Further, it incorporates the latest 3.3V DC-compatible transceiver technology including an 850-nm VCSEL transmitter as well as a convenient LC-Duplex optical interface.

The AFBR-5718APZ offers maximum flexibility to designers, manufacturers, and operators of Gigabit Ethernet networking equipment. A pluggable architecture allows the module to be installed into MSA standard SFP ports at any time, even with the host equipment operating and online. This facilitates the rapid configuration of equipment to precisely the user's needs, reducing inventory costs and network downtime. Compared with traditional transceivers, the size of the small form-factor package enables higher port densities.

Part Number Ordering Options

Part Number	DMI	Temperature	Latch
AFBR-5718APZ	Yes	-10°C to 85°C	Standard

Features

- ROHS-6 compliant
- IEEE 802.3 Gigabit Ethernet (1.25 Gbd) 1000BASE-SX compliant
- Small form-factor pluggable (SFP) multisource agreement (MSA) compliant
- Manufactured in an ISO 9001-compliant facility
- Hot-pluggable
- DMI support per MSA SFF-8472 to enable a diagnostic monitoring interface for optical transceivers with real-time monitoring of the following parameters:
 - Transmitted optical power
 - Received optical power
 - Laser bias current
 - Temperature
 - Supply voltage
- +3.3V DC power supply
- Industry-leading EMI performance for high port density
- 850-nm Vertical Cavity Surface Emitting Laser (VCSEL)
- Eye-safety certified
- LC-Duplex fiber connector compatible
- Fiber compatibility at the following conditions:
 - 2 to 550 meters with 50 μm/125 μm fiber
 - 2 to 275 meters with 62.5 μm/125 μm fiber

Applications

- Ethernet switches
- Multiservice switches and routers
- Broadband aggregation and wireless infrastructure
- Switched-backplane applications
- Switch-to-switch and server interfaces
- iSCSI applications

Module Diagrams

Figure 1 illustrates the major functional components of the AFBR-5718APZ. The external configuration of the module is depicted in Figure 7.

Figure 1: AFBR-5781APZ Block Diagram

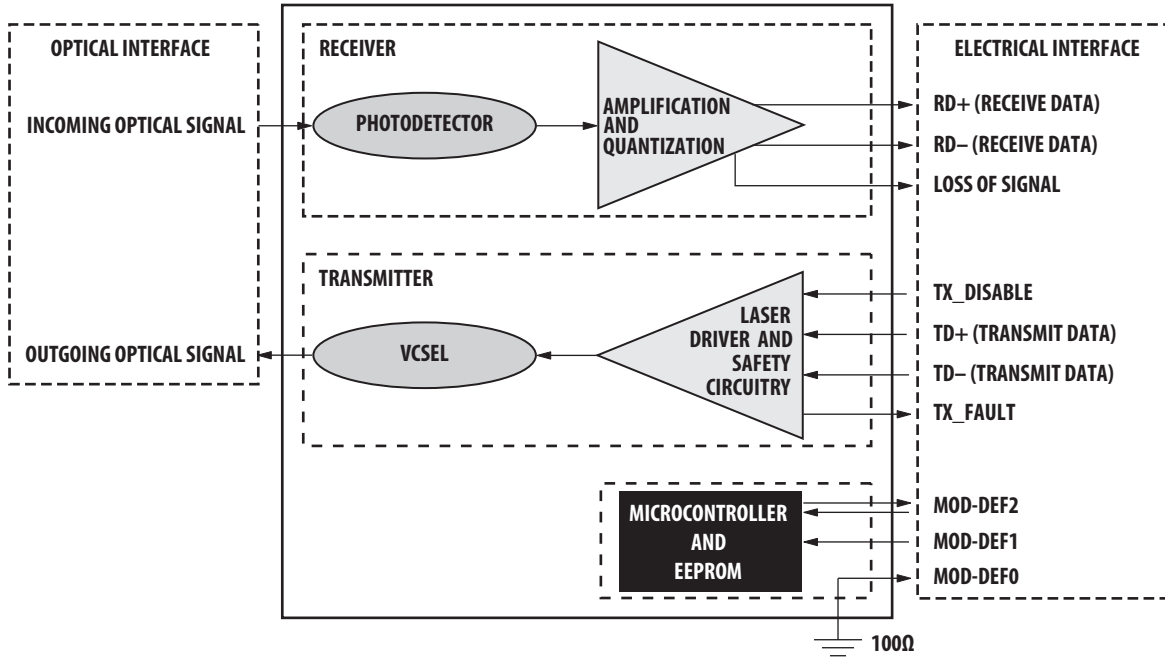
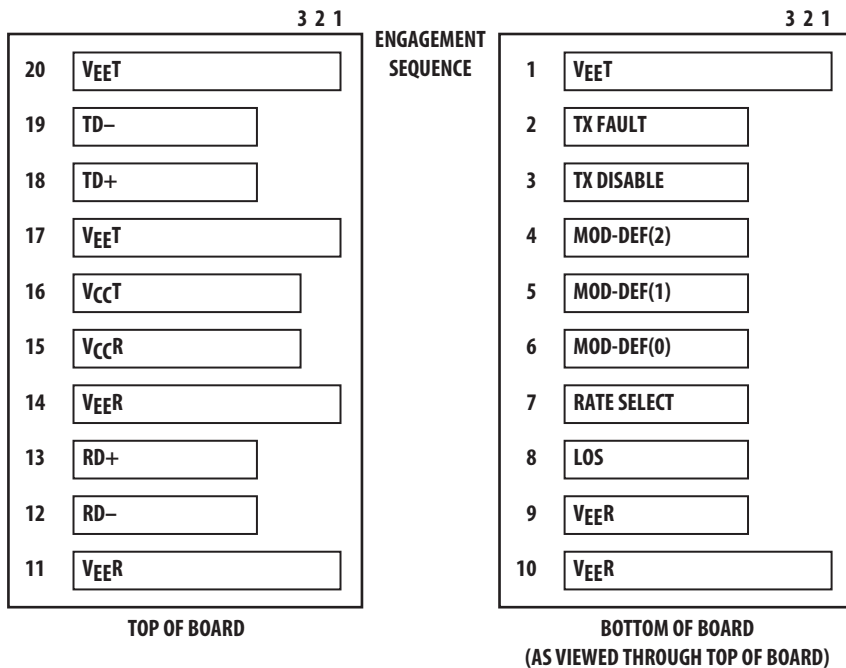

Figure 2: Pin Description of the SFP Electrical Interface



Installation

The AFBR-5718APZ can be installed in or removed from any MSA-compliant pluggable small form-factor port regardless of whether the host equipment is operating. The module is simply inserted, electrical interface first, under finger-pressure. Controlled hot-plugging is ensured by three-stage pin sequencing at the electrical interface. This printed circuit board (PCB) card-edge connector is depicted in [Figure 2](#).

As the AFBR-5718APZ is inserted, first contact is made by the housing ground shield, discharging any potentially component-damaging static electricity. Ground pins engage next and are followed by TX and RX power supplies. Finally, signal lines are connected. Pin functions and sequencing are listed in the [Pin Descriptions Table](#).

For easier fingertip delatching in high port-density applications, an optional bail-wire tab is provided.

Operating Temperature

The AFBR-5718APZ transceiver is available in -40°C to $+85^{\circ}\text{C}$ operating temperature range.

Serial Identification (EEPROM)

The AFBR-5718APZ features an EEPROM for Serial ID. It contains the product data stored for retrieval by host equipment. This data is accessed via the two-wire serial EEPROM protocol of the ATMEL AT24C01A or similar in compliance with the industry standard SFP MSA. Contents of the AFBR-5718APZ serial ID memory are displayed in the [Transceiver Digital Diagnostic Monitor \(Real-Time Sense\) Characteristics](#) table.

Transmitter Section

The transmitter section includes the transmitter optical subassembly (TOSA) and laser driver circuitry. The TOSA contains an 850-nm vertical cavity surface emitting laser (VCSEL) light source, is located at the optical interface, and mates with the LC optical connector.

The TOSA is driven by a custom IC, which converts differential logic signals into an analog laser diode drive current. This TX driver circuit regulates the optical power at a constant level provided the data pattern is DC balanced, as in 8B10B code.

TX Disable

The AFBR-5718APZ accepts a transmit disable control signal input, which shuts down the transmitter. A high signal implements this function while a low signal allows normal laser operation. In the event of a fault, for example if the eye safety circuit is activated, cycling this control signal resets the module as depicted in [Figure 6](#).

Customer Manufacturing Processes

This module is pluggable and is not designed for aqueous wash, IR reflow, or wave soldering process.

Eye Safety Circuit

The AFBR-5718APZ provides Class 1 eye safety by design and has been tested for compliance with the requirements listed in the [Regulatory Compliance Table](#).

The eye safety circuit continuously monitors optical output power levels and will disable the transmitter and assert a TX_FAULT signal upon detecting an unsafe condition. Such unsafe conditions can be created by inputs from the host board (V_{CC} fluctuation, unbalanced code) or faults within the module.

Receiver Section

The receiver section includes the receiver optical subassembly (ROSA) and amplification/quantization circuitry. The ROSA, containing a PIN photodiode and a custom trans-impedance preamplifier, is located at the optical interface and mates with the LC optical connector. The ROSA is mated to a custom IC that provides post-amplification and quantization. Also included is a loss of signal (LOS) detection circuit.

Loss of Signal

The loss of signal (LOS) output indicates an unusable optical input power level. A high LOS output signal indicates a loss of signal while a low LOS output signal indicates normal operation. The Loss Of Signal thresholds are set to indicate a definite optical fault has occurred, such as a disconnected or broken fiber connection to receiver, or a failed transmitter.

Functional I/O

The AFBR-5718APZ accepts industry-standard differential signals within the scope of the SFP MSA. To simplify board requirements, transmitter bias resistors and coupling capacitors are incorporated into the transceiver module. The module is AC-coupled and internally terminated.

Figure 4 illustrates a recommended interface circuit to link the AFBR-5718APZ to the supporting physical layer integrated circuits.

Timing diagrams for the MSA compliant control signals implemented in this module are depicted in Figure 6

Required Host Board Components

The MSA power supply noise rejection filter is required on the host PCB to meet data sheet performance. The required filter is illustrated in Figure 3.

Figure 3: MSA-Required Power Supply Filter

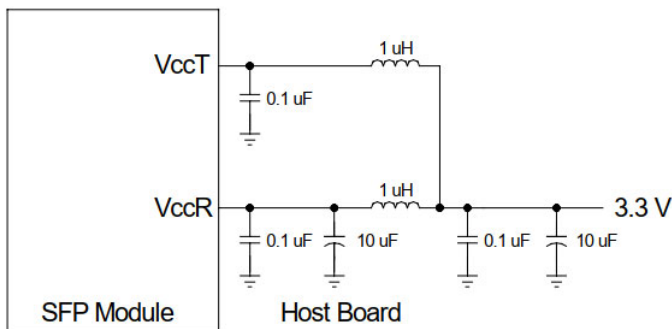

The MSA also specifies that 4.7K Ω to 10 K Ω pull-up resistors for TX_FAULT, LOS, and MOD_DEF0,1,2 are required on the host PCB.

Application Support

Evaluation Kit

To assist in the transceiver evaluation process, Broadcom offers a 1.25-Gbaud Gigabit Ethernet evaluation board that facilitates testing of the AFBR-5718APZ. It can be obtained from your sales representative (reference part number AFBR-0571Z.)

Reference Designs

A reference design including the AFBR-5718APZ and the HDMP-1687 GigaBit Quad SerDes is available. Contact your sales representative for more information.

Regulatory Compliance

Refer to the [Regulatory Compliance Table](#) for transceiver Regulatory Compliance information. Certification level is dependent on the overall configuration of the host equipment. The transceiver performance is offered as a figure of merit to assist the designer.

Electrostatic Discharge (ESD)

There are two design cases in which immunity to ESD damage is important:

- The first case is during handling of the transceiver prior to insertion into the transceiver port. To protect the transceiver, it is important to use normal ESD handling precautions. These precautions include using grounded wrist straps, work benches, and floor mats in ESD controlled areas. The ESD sensitivity of the AFBR-5718APZ is compatible with typical industry production environments.
- The second case to consider is static discharges to the exterior of the host equipment chassis after installation. To the extent that the optical interface is exposed to the outside of the host equipment chassis, it may be subject to system-level ESD requirements.

Immunity

The AFBR-5718APZ meets the applicable operational requirements for radio frequency immunity when tested in accordance with IEC 61000-4-3 and GR-1089. Equipment hosting AFBR-5718APZ modules will be subjected to radio-frequency electromagnetic fields in some environments. The transceiver has good immunity to such fields due to its shielded design.

Electromagnetic Interference (EMI)

The AFBR-5718APZ meets the applicable Class B requirements for electromagnetic emissions including FCC Part 15 and CISPR22. The metal housing and shielded design of the AFBR-5718APZ minimize the EMI challenge facing the host equipment designer.

Flammability

The AFBR-5718APZ transceiver is made of metal and high strength, heat-resistant, chemical-resistant, and UL 94V-0 flame-retardant plastic.

Caution

There are no user-serviceable parts nor any maintenance required for the AFBR-5718APZ. All adjustments are made at the factory before shipment to customers.

Tampering with, modifying, misusing or improperly handling the AFBR-5718APZ will void the product warranty. It can also result in improper operation of the AFBR-5718APZ circuitry, and possible overstress of the laser source. Device degradation or product failure can result.

Connecting the AFBR-5718APZ to a non-Gigabit Ethernet-compliant optical source, operating above the recommended absolute maximum conditions, or operating the AFBR-5718APZ in a manner inconsistent with its design and function can result in hazardous radiation exposure and can be considered an act of modifying or manufacturing a laser product. The person performing such an act is required by law to re-certify and re-identify the laser product under the provisions of U.S. 21 CFR, Subchapter J.

Figure 4: Typical Application Configuration

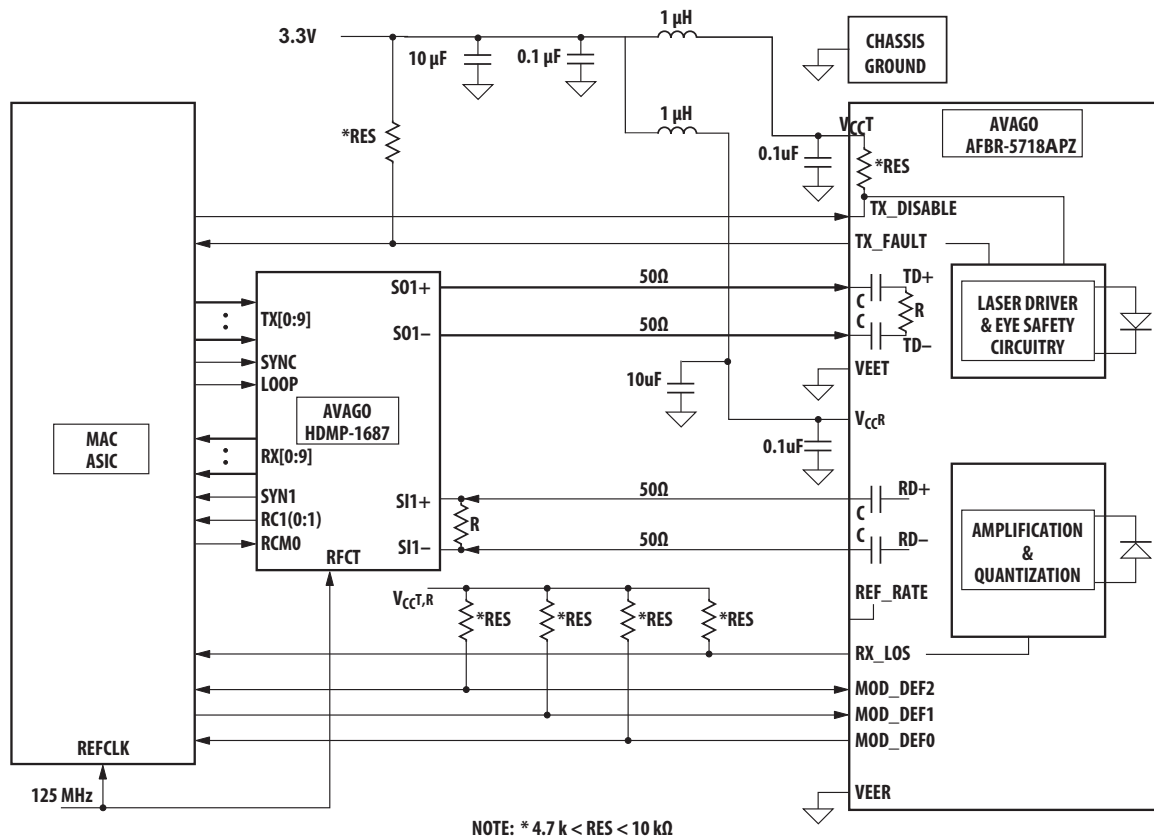

Regulatory Compliance Table

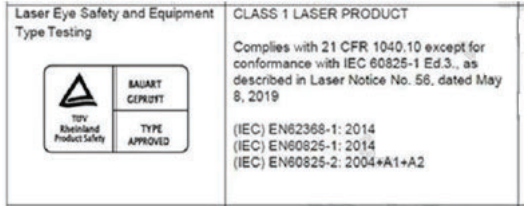
Feature	Test Method	Performance
Electrostatic Discharge (ESD) to the Electrical Pins	JEDEC/EIA JESD22-A114-A	Class 2 (> +2000V).
Electrostatic Discharge (ESD) to the Duplex LC Receptacle	Variation of IEC 6100-4-2	Typically withstands at least 25 kV without damage when the duplex LC connector receptacle is contacted by a human body model probe.
Electromagnetic Interference (EMI) (CISPR 22A) VCCI Class 1	FCC Class B CENELEC EN55022 Class B dependent on customer board and chassis	Applications with high SFP port counts are expected to be compliant; however, margins are design.
Immunity	Variation of IEC 61000-4-3	Typically shows a negligible effect from a 10-V/m field swept from 80 MHz to 1000 MHz applied to the transceiver without a chassis enclosure.
Eye Safety ^a	US FDA CDRH AEL Class 1 EN(IEC)60825-1,2, EN60950 Class 1	CDRH certification #2120722-000. TUV file #R72201324. 
Component Recognition	Underwriters Laboratories and Canadian Standards Association Joint Component Recognition for Information Technology Equipment Including Electrical Business Equipment	UL File: #E484615.

- a. Changes to IEC 60825-1,2 are currently anticipated to allow higher eye-safe optical output power levels. Broadcom may choose to take advantage of these in future revisions to this part.

Pin Descriptions Table

Pin	Name	Function and Description	Engagement Order (insertion)	Notes
1	V _{EE} T	Transmitter Ground	1	—
2	TX Fault	Transmitter Fault Indication	3	a
3	TX Disable	Transmitter Disable: Module disables on high or open	3	b
4	MOD-DEF2	Module Definition 2: Two-wire serial ID interface	3	c
5	MOD-DEF1	Module Definition 1: Two-wire serial ID interface	3	c
6	MOD-DEF0	Module Definition 0: Grounded through 100Ω in module	3	c
7	Rate Select	Not Used	3	—
8	LOS	Loss of Signal	3	d
9	V _{EE} R	Receiver Ground	1	—
10	V _{EE} R	Receiver Ground	1	—
11	V _{EE} R	Receiver Ground	1	—
12	RD-	Inverse Received Data Out	3	e
13	RD+	Received Data Out	3	e
14	V _{EE} R	Receiver Ground	1	—
15	V _{CC} R	Receiver Power: 3.3V ± 5%	2	f
16	V _{CC} T	Transmitter Power: 3.3V ± 5%	2	f
17	V _{EE} T	Transmitter Ground	1	—
18	TD+	Transmitter Data In	3	g
19	TD-	Inverse Transmitter Data In	3	g
20	V _{EE} T	Transmitter Ground	1	—

- a. TX Fault is an open collector/drain output that should be pulled up externally with a 4.7 KΩ to 10 KΩ resistor on the host board to a supply $V_{CC,T} + 0.3V$ or $V_{CC,R} + 0.3V$. When high, this output indicates a laser fault of some kind. Low indicates normal operation. In the low state, the output will be pulled to <math><0.8V</math>.
- b. The TX disable input is used to shut down the laser output per the state table below. It is pulled up within the module with a 4.7-10K resistor.
 Low (0V to 0.8V): Transmitter on.
 Between 0.8V and 2.0V: Undefined.
 High (2.0V to 3.465V): Transmitter Disabled.
 Open: Transmitter Disabled.
- c. Mod-Def 0,1,2 are the module definition pins. They should be pulled up with a 4.7 KΩ to 10 KΩ resistor on the host board to a supply less than $V_{CC,T} + 0.3V$ or $V_{CC,R} + 0.3V$.
 Mod-Def 0 is pulled low by the module to indicate that the module is present.
 Mod-Def 1 is clock line of two wire serial interface for optional serial ID.
 Mod-Def 2 is data line of two wire serial interface for optional serial ID.
- d. LOS (Loss of Signal) is an open collector/drain output which should be pulled up externally with a 4.7 KΩ to 10 KΩ resistor on the host board to a supply $V_{CC,T,R} + 0.3V$. When high, this output indicates the received optical power is below the worst case receiver sensitivity (as defined by the standard in use). Low indicates normal operation. In the low state, the output will be pulled to <math><0.8V</math>.
- e. RD± are the differential receiver outputs. They are AC-coupled 100Ω differential lines which should be terminated with 100Ω differential at the user SERDES. The AC-coupling is done inside the module and is thus not required on the host board.
- f. V_{CC}R and V_{CC}T are the receiver and transmitter power supplies. They are defined as 3.135V to 3.465V at the SFP connector pin. The in-rush current, measured before the filter network, will typically be no more than 30 mA above steady state supply current after 500 ns.
- g. TD± are the differential transmitter inputs. They are AC-coupled differential lines with 100Ω differential termination inside the module. The AC-coupling is done inside the module and is thus not required on the host board.

Absolute Maximum Ratings

Parameter	Symbol	Min.	Max.	Unit	Notes
Ambient Storage Temperature (Non-Operating)	T_S	-40	85	°C	a
Case Temperature	T_C	-40	85	°C	a
Relative Humidity	RH	5	95	%	a
Supply Voltage	$V_{CC,T,R}$	-0.3	3.6	V	a
Voltage at Any Input Pin	V_{IH}	-0.3	$V_{CC}+0.5$	V	a

a. Absolute Maximum Ratings are those values beyond which damage to the device may occur if these limits are exceeded. Refer to the reliability data sheet for specific reliability performance.

Recommended Operating Conditions

Parameter	Symbol	Min.	Typ.	Max.	Unit	Notes
Case Temperature	T_C	-40	25	85	°C	a, b
Supply Voltage	V_{CC}	3.14	3.3	3.47	V	a
Data Rate	Gb/s	—	—	1.25	—	—
A2 Page Endurance	R/W cycle	—	—	100,000	—	—

a. Recommended Operating Conditions are those within which functional performance within data sheet characteristics is intended.

b. Refer to the reliability data sheet for specific reliability performance predictions.

Transceiver Electrical Characteristics

$T_C = -40^\circ\text{C}$ to 85°C , $V_{CC,T,R} = 3.3\text{V} \pm 5\%$

Parameter	Symbol	Min.	Typ.	Max.	Unit	Notes
Module Supply Current	I_{CC}	—	170	202	mA	—
Power Dissipation	P_{DISS}	—	560	700	mW	—
Power Supply Noise Rejection (Peak-to-Peak)	P_{SNR}	—	—	100	mVPP	a
Data Input: Transmitter Differential Input Voltage (TD \pm)	V_I	500	—	2400	mVPP	b
Data Output: Receiver Differential Output Voltage (RD \pm)	V_O	370	—	1200	mVPP	c
Receive Data Rise and Fall Times	T_{rf}	—	—	350	ps	—
Sense Outputs: Transmit Fault [TX_FAULT, Loss of Signal (LOS), MOD_DEF2]	V_{OH}	2.0	—	$V_{CC,T,R} + 0.3$	V	—
	V_{OL}	0	—	0.8	V	—
Control Inputs: Transmitter Disable [TX_DISABLE, MOD_DEF1,2]	V_{IH}	2.0	—	V_{CC}	V	—
	V_{IL}	0	—	0.8	V	—

a. Measured at the input of the filter illustrated in [Figure 3](#) from 20 Hz to 155 MHz.

b. Internally AC-coupled and terminated to 100 Ω differential load.

c. Internally AC-coupled, but requires a 100 Ω differential termination at or internal to serializer/deserializer.

Transmitter Optical Characteristics

$T_C = -40^\circ\text{C}$ to 85°C , $V_{CC,T,R} = 3.3\text{V} \pm 5\%$

Parameter	Symbol	Min.	Typ.	Max.	Unit	Notes
Output Optical Power, Average	P_{OUT}	-9.5	-6.5	-3	dBm	a
Optical Extinction Ratio	ER	9	11	—	dB	a
Center Wavelength	λ_C	830	850	860	nm	a
Spectral Width: rms	σ	—	—	0.85	nm	a
Optical Rise/Fall Time	$T_{rise/fall}$	—	—	260	ps	a
Relative Intensity Noise, Maximum	RIN	—	—	-117	dB/Hz	a
Total Jitter (TP1 to TP2 Contribution)	TJ	—	—	227	ps	a
		—	—	0.284	UI	a
Pout TX_DISABLE Asserted	P_{OFF}	—	—	-30	dBm	a
Coupled Power Ratio	CPR	9	—	—	dB	—

a. 50 μm /125 μm fiber with NA = 0.2; 62.5 μm /125 μm fiber with NA = 0.275.

Figure 5: Gigabit Ethernet Transmitter Eye Mask Diagram

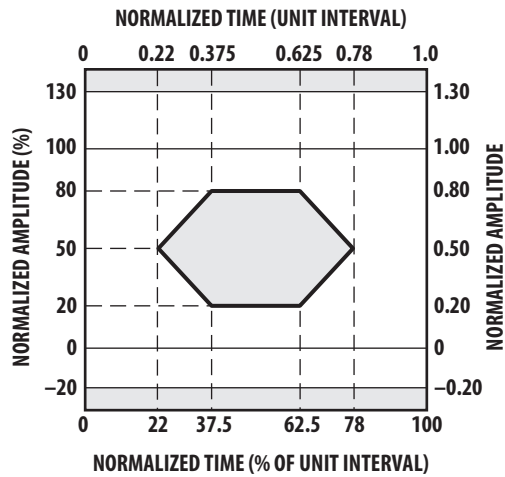

Receiver Optical Characteristics

$T_C = -40^{\circ}\text{C}$ to 85°C , $V_{CC,T,R} = 3.3\text{V} \pm 5\%$

Parameter	Symbol	Min.	Typ.	Max.	Unit	Notes
Optical Input Power	PR	-17	—	0	dBm	a
Receiver Sensitivity (Optical Input Power)	PRMIN	—	—	-17	dBm	a
Stressed Receiver Sensitivity	—	—	—	-12.5	dBm	a, b
		—	—	-13.5	dBm	a, c
Total Jitter (TP3 to TP4 Contribution)	TJ	—	—	266	ps	a
		—	—	0.332	UI	a
Return Loss	—	—	—	-12	dB	a
LOS De-Asserted	P_D	—	—	-17	dBm	a
LOS Asserted	P_A	-31	—	—	dBm	a
LOS Hysteresis	$P_D - P_A$	0.5	—	6	dB	a

- a. IEEE 802.3.
- b. 62.5 μm /125 μm fiber.
- c. 50 μm /125 μm fiber.

Transceiver Timing Characteristics

$T_C = -40^{\circ}\text{C}$ to 85°C , $V_{CC,T,R} = 3.3\text{V} \pm 5\%$

Parameter	Symbol	Min.	Typ.	Max.	Unit	Notes
TX Disable Assert Time	t_{off}	—	—	10	μs	a
TX Disable Negate Time	t_{on}	—	—	1	ms	b
Time to Initialize, Including Reset of TX_Fault	t_{init}	—	—	300	ms	c
TX Fault Assert Time	t_{fault}	—	—	100	μs	d
TX Disable to Reset	t_{reset}	10	—	—	μs	e
LOS Assert Time	$t_{\text{loss_on}}$	—	—	100	μs	f
LOS Deassert Time	$t_{\text{loss_off}}$	—	—	100	μs	g
Serial ID Clock Rate	$f_{\text{serial_clock}}$	—	—	400	kHz	—

- a. Time from rising edge of TX Disable to when the optical output falls below 10% of nominal.
- b. Time from falling edge of TX Disable to when the modulated optical output rises above 90% of nominal.
- c. From power on or negation of TX Fault using TX Disable.
- d. Time from fault to TX fault on.
- e. Time TX Disable must be held high to reset TX_fault
- f. Time from LOS state to RX LOS assert.
- g. Time from non-LOS state to RX LOS deassert.

Transceiver Digital Diagnostic Monitor (Real-Time Sense) Characteristics

$T_C = -40^{\circ}\text{C}$ to 85°C , $V_{CC,T}$, $V_{CC,R} = 3.3\text{V} \pm 10\%$

Parameter	Symbol	Min.	Unit	Notes
Transceiver Internal Temperature Accuracy	T_{INT}	± 3.0	$^{\circ}\text{C}$	Temperature is measured internal to the transceiver. Valid from -40°C to 85°C case temperature.
Transceiver Internal Supply Voltage Accuracy	V_{INT}	± 0.1	V	Supply voltage is measured internal to the transceiver and can, with less accuracy, be correlated to voltage at the SFP V_{CC} pin. Valid over $3.3\text{V} \pm 10\%$.
Transmitter Laser DC Bias Current Accuracy	I_{INT}	± 10	%	I_{INT} is better than $\pm 10\%$ of the nominal value.
Transmitted Average Optical Output Power Accuracy	P_T	± 3.0	dB	Coupled into $50\ \mu\text{m}/125\ \mu\text{m}$ multimode fiber. Valid from $100\ \mu\text{W}$ to $500\ \mu\text{W}$, avg.
Received Average Optical Input Power Accuracy	P_R	± 2.0	dB	Coupled into $50\ \mu\text{m}/125\ \mu\text{m}$ multimode fiber. Valid from 0 to -19 dB.

Figure 6: Transceiver Timing Diagrams (Module Installed Except Where Noted)

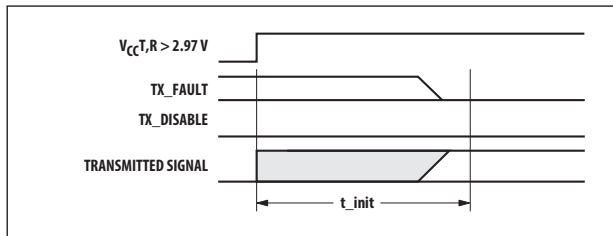

t-init: TX DISABLE NEGATED

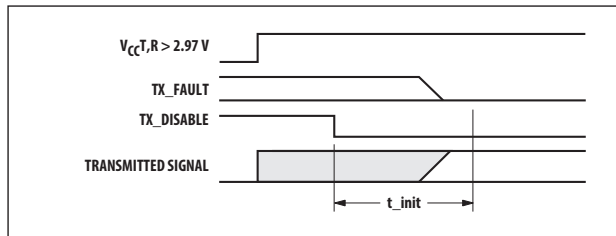

t-init: TX DISABLE ASSERTED

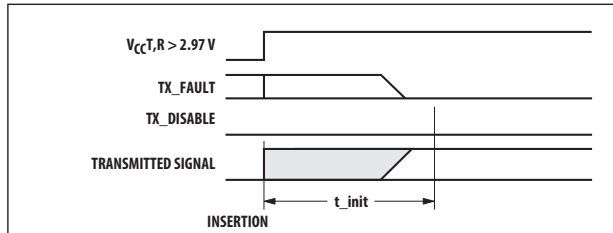

t-init: TX DISABLE NEGATED, MODULE HOT PLUGGED

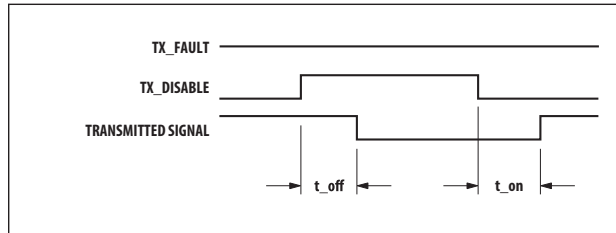

t-off & t-on: TX DISABLE ASSERTED THEN NEGATED

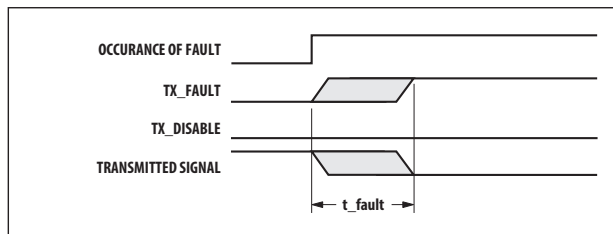

t-fault: TX FAULT ASSERTED, TX SIGNAL NOT RECOVERED

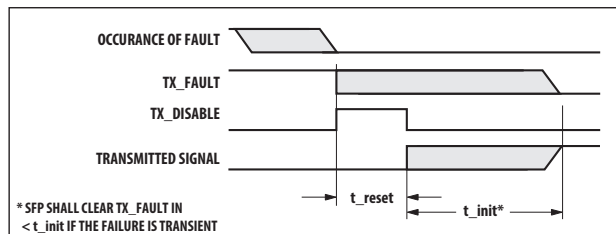

t-reset: TX DISABLE ASSERTED THEN NEGATED, TX SIGNAL RECOVERED

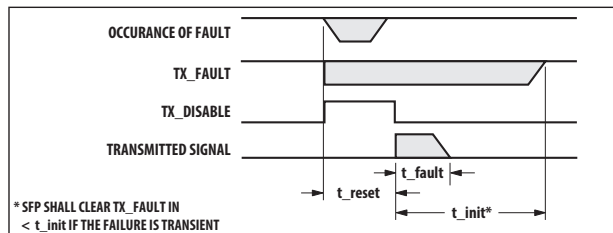

t-fault: TX DISABLE ASSERTED THEN NEGATED, TX SIGNAL NOT RECOVERED

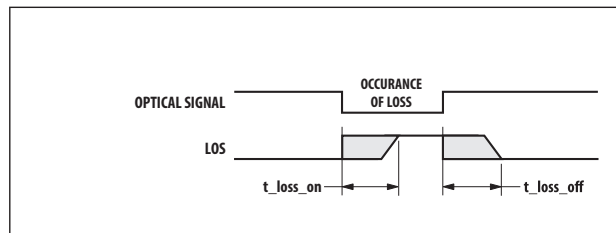

t-loss-on & t-loss-off

EEPROM Serial ID Memory

Table 1: EEPROM Serial ID Memory Contents, Page A0h^a

Byte		Data Notes	Byte		Data Notes
Decimal	Hex		Decimal	Hex	
0	03	SFP physical device	37	00	Vendor OUI ^b
1	04	SFP function defined by serial ID only	38	17	Vendor OUI ^b
2	07	LC optical connector	39	6A	Vendor OUI ^b
3	00	—	40	41	"A" Vendor Part Number ASCII character
4	00	—	41	46	"F" Vendor Part Number ASCII character
5	00	—	42	42	"B" Vendor Part Number ASCII character
6	01	1000BaseSX	43	52	"R" Vendor Part Number ASCII character
7	00	—	44	2D	"-" Vendor Part Number ASCII character
8	00	—	45	35	"5" Vendor Part Number ASCII character
9	00	—	46	37	"7" Vendor Part Number ASCII character
10	00	—	47	31	"1" Vendor Part Number ASCII character
11	01	Compatible with 8B/10B encoded data	48	38	"8" Vendor Part Number ASCII character
12	0C	1200 Mb/s nominal bit rate (1.25 Gb/s)	49	41	"A" Vendor Part Number ASCII character
13	00	—	50	50	"P" Vendor Part Number ASCII character
14	00	—	51	5A	"Z" Vendor Part Number ASCII character
15	00	—	52	20	" " Vendor Part Number ASCII character
16	37	550m of 50/125-mm fiber at 1.25 Gb/s ^c	53	20	" " Vendor Part Number ASCII character
17	1B	275m of 62.5/125-mm fiber at 1.25 Gb/s ^d	54	20	" " Vendor Part Number ASCII character
18	00	—	55	20	" " Vendor Part Number ASCII character
19	00	—	56	20	" " Vendor Revision Number ASCII character
20	41	'A' Vendor Name ASCII character	57	20	" " Vendor Revision Number ASCII character
21	56	"V" Vendor Name ASCII character	58	20	" " Vendor Revision Number ASCII character
22	41	"A" Vendor Name ASCII character	59	20	" " Vendor Revision Number ASCII character
23	47	"G" Vendor Name ASCII character	60	03	Hex Byte of Laser Wavelength ^e
24	4F	"O" Vendor Name ASCII character	61	52	Hex Byte of Laser Wavelength ^e
25	20	" " Vendor Name ASCII character	62	00	—
26	20	" " Vendor Name ASCII character	63	—	Checksum for bytes 0-62 ^f
27	20	" " Vendor Name ASCII character	64	00	—
28	20	" " Vendor Name ASCII character	65	1A	Hardware SFP TX_DISABLE, TX_FAULT, & RX_LOS
29	20	" " Vendor Name ASCII character	66	00	—
30	20	" " Vendor Name ASCII character	67	00	—
31	20	" " Vendor Name ASCII character	68-83	—	Vendor Serial Number, ASCII ^g

Table 1: EEPROM Serial ID Memory Contents, Page A0h^a

Byte		Data Notes	Byte		Data Notes
Decimal	Hex		Decimal	Hex	
32	20	“ “ Vendor Name ASCII character	84-91	—	Vendor Date Code, ASCII ^h
33	20	“ “ Vendor Name ASCII character	92	—	i
34	20	“ “ Vendor Name ASCII character	93	—	i
35	20	“ “ Vendor Name ASCII character	94	—	i
36	00	—	95	—	Checksum for bytes 64-94 ^f
—	—	—	96 - 255	00	—

- a. FC-PI speed 100 MB/s is a serial bit rate of 1.0625 Gb/s.
- b. The IEEE Organizationally Unique Identifier (OUI) assigned to Avago is 00-17-6A (3 bytes of hex).
- c. Link distance with 50 μm /125 μm cable at 1.25 Gb/s is 550m.
- d. Link distance with 62.5 μm /125 μm cable at 1.25 Gb/s is 275m.
- e. Laser wavelength is represented in 16 unsigned bits. The hex representation of 850 nm is 0352.
- f. Addresses 63 and 95 are checksums calculated per SFF-8472 and SFF-8074, and stored prior to product shipment.
- g. Addresses 68-83 specify the module's ASCII serial number and will vary by unit.
- h. Addresses 84-91 specify the module's ASCII date code and will vary according to manufactured date-code.
- i. Refer to [Table 2](#) for part number extensions and data fields.

Table 2: EEPROM Serial ID Memory Contents - Address A2h

Byte Decimal	Notes	Byte Decimal	Notes	Byte Decimal	Notes
0	Temp H Alarm MSB ^a	26	TX Pwr L Alarm MSB ^j	104	Real Time RX P _{AV} MSB ^b
1	Temp H Alarm LSB ^a	27	TX Pwr L Alarm LSB ^j	105	Real Time RX P _{AV} LSB ^b
2	Temp L Alarm MSB ^a	28	TX Pwr H Warning MSB ^j	106	Reserved
3	Temp L Alarm LSB ^a	29	TX Pwr H Warning LSB ^j	107	Reserved
4	Temp H Warning MSB ^a	30	TX Pwr L Warning MSB ^j	108	Reserved
5	Temp H Warning LSB ^a	31	TX Pwr L Warning LSB ^j	109	Reserved
6	Temp L Warning MSB ^a	32	RX Pwr H Alarm MSB ^b	110	Status/Control ^c
7	Temp L Warning LSB ^a	33	RX Pwr H Alarm LSB ^b	111	Reserved
8	V _{CC} H Alarm MSB ^d	34	RX Pwr L Alarm MSB ^b	112	Flag Bits ^e
9	V _{CC} H Alarm LSB ^d	35	RX Pwr L Alarm LSB ^b	113	Flag Bit ^e
10	V _{CC} L Alarm MSB ^d	36	RX Pwr H Warning MSB ^b	114	Reserved
11	V _{CC} L Alarm LSB ^d	37	RX Pwr H Warning LSB ^b	115	Reserved
12	V _{CC} H Warning MSB ^d	38	RX Pwr L Warning MSB ^b	116	Flag Bits ^e
13	V _{CC} V _{CC} H Warning LSB ^d	39	RX Pwr L Warning LSB ^b	117	Flag Bits ^e
14	V _{CC} L Warning MSB ^d	40-55	Reserved	118	Reserved
15	V _{CC} L Warning LSB ^d	56-94	External Calibration Constants ^f	119	Reserved
16	TX Bias H Alarm MSB ^g	95	Checksum for Bytes 0-94 ^h	120-122	Vendor Specific

Table 2: EEPROM Serial ID Memory Contents - Address A2h

Byte Decimal	Notes	Byte Decimal	Notes	Byte Decimal	Notes
17	TX Bias H Alarm LSB ^g	96	Real-Time Temperature MSB ^a	123	Vendor Specific
18	TX Bias L Alarm MSB ^g	97	Real-Time Temperature LSB ^a	124	Vendor Specific
19	TX Bias L Alarm LSB ^g	98	Real-Time V _{CC} MSB ^d	125	Vendor Specific
20	TX Bias H Warning MSB ^g	99	Real-Time V _{CC} LSB ^d	126	Vendor Specific
21	TX Bias H Warning LSB ^g	100	Real-Time TX Bias MSB ^g	127	Vendor Specific
22	TX Bias L Warning MSB ^g	101	Real-Time TX Bias LSB ^g	128-247	Customer Writable ⁱ
23	TX Bias L Warning LSB ^g	102	Real-Time TX Power MSB ^j	248-255	Vendor Specific
24	TX Pwr H Alarm MSB ^j	103	Real-Time TX Power LSB ^j	—	—
25	TX Pwr H Alarm LSB ^j	—	—	—	—

- Temperature (Temp) is decoded as a 16-bit signed twos complement integer in increments of 1/256°C.
- Received average optical power (RX Pwr) is decoded as a 16-bit unsigned integer in increments of 0.1 μW.
- Refer to [Table 3](#).
- Supply voltage (V_{CC}) is decoded as a 16-bit unsigned integer in increments of 100 μV.
- Refer to [Table 4](#).
- Bytes 55-94 have been set to default values per SFF-8472.
- Laser bias current (TX Bias) is decoded as a 16-bit unsigned integer in increments of 2 μA.
- Bytes 95 is a checksum calculated (per SFF-8472) and stored prior to product shipment.
- Bytes 128-247 are write-enabled (customer writable).
- Transmitted average optical power (TX Pwr) is decoded as a 16-bit unsigned integer in increments of 0.1 μW.

Table 3: EEPROM Serial ID Memory Contents - Address A2h, Byte 110

Bit	Status/Control Name	Description
7	TX Disable State	Digital state of SFP TX Disable input pin (1 = TX_Disable asserted).
6	Soft TX Disable	Read/write bit for changing digital state of SFP TX_Disable function ^a .
5	Reserved	—
4	RX Rate Select State	Digital state of SFP Rate Select input pin (1 = Full bandwidth of 155 Mb).
3	Reserved	—
2	TX Fault State	Digital state of the SFP TX Fault output pin (1 = TX Fault asserted).
1	RX LOS State	Digital state of the SFP LOS output pin (1 = LOS asserted).
0	Data Ready (Bar)	Indicates transceiver is powered and real-time sense data is ready (0 = Ready).

- Bit 6 is logic OR'd with the SFP TX_Disable input pin 3. Either asserted will disable the SFP transmitter.

Table 4: EEPROM Serial ID Memory Contents - Address A2h, Bytes 112, 113, 116, 117

Byte	Bit	Status/Control Name	Description
112	7	Temp High Alarm	Set when transceiver internal temperature exceeds high alarm threshold.
	6	Temp Low Alarm	Set when transceiver internal temperature exceeds low alarm threshold.
	5	V _{CC} High Alarm	Set when transceiver internal supply voltage exceeds high alarm threshold.
	4	V _{CC} Low Alarm	Set when transceiver internal supply voltage exceeds low alarm threshold.
	3	TX Bias High Alarm	Set when transceiver laser bias current exceeds high alarm threshold.
	2	TX Bias Low Alarm	Set when transceiver laser bias current exceeds low alarm threshold.
	1	TX Power High Alarm	Set when transceiver average optical power exceeds high alarm threshold.
	0	TX Power Low Alarm	Set when transceiver average optical power exceeds low alarm threshold.
113	7	RX Power High Alarm	Set when received P _{Avg} optical power exceeds high alarm threshold.
	6	RX Power Low Alarm	Set when received P _{Avg} optical power exceeds low alarm threshold.
	0-5	Reserved	—
116	7	Temp High Warning	Set when transceiver internal temperature exceeds high warning threshold.
	6	Temp Low Warning	Set when transceiver internal temperature exceeds low warning threshold.
	5	V _{CC} High Warning	Set when transceiver internal supply voltage exceeds high warning threshold.
	4	V _{CC} Low Warning	Set when transceiver internal supply voltage exceeds low warning threshold.
	3	TX Bias High Warning	Set when transceiver laser bias current exceeds high warning threshold.
	2	TX Bias Low Warning	Set when transceiver laser bias current exceeds low warning threshold.
	1	TX Power High Warning	Set when transceiver average optical power exceeds high warning threshold.
	0	TX Power Low Warning	Set when transceiver average optical power exceeds low warning threshold.
117	7	RX Power High Warning	Set when received P _{Avg} optical power exceeds high warning threshold.
	6	RX Power Low Warning	Set when received P _{Avg} optical power exceeds low warning threshold.
	0-5	Reserved	—

Figure 7: Module Drawing

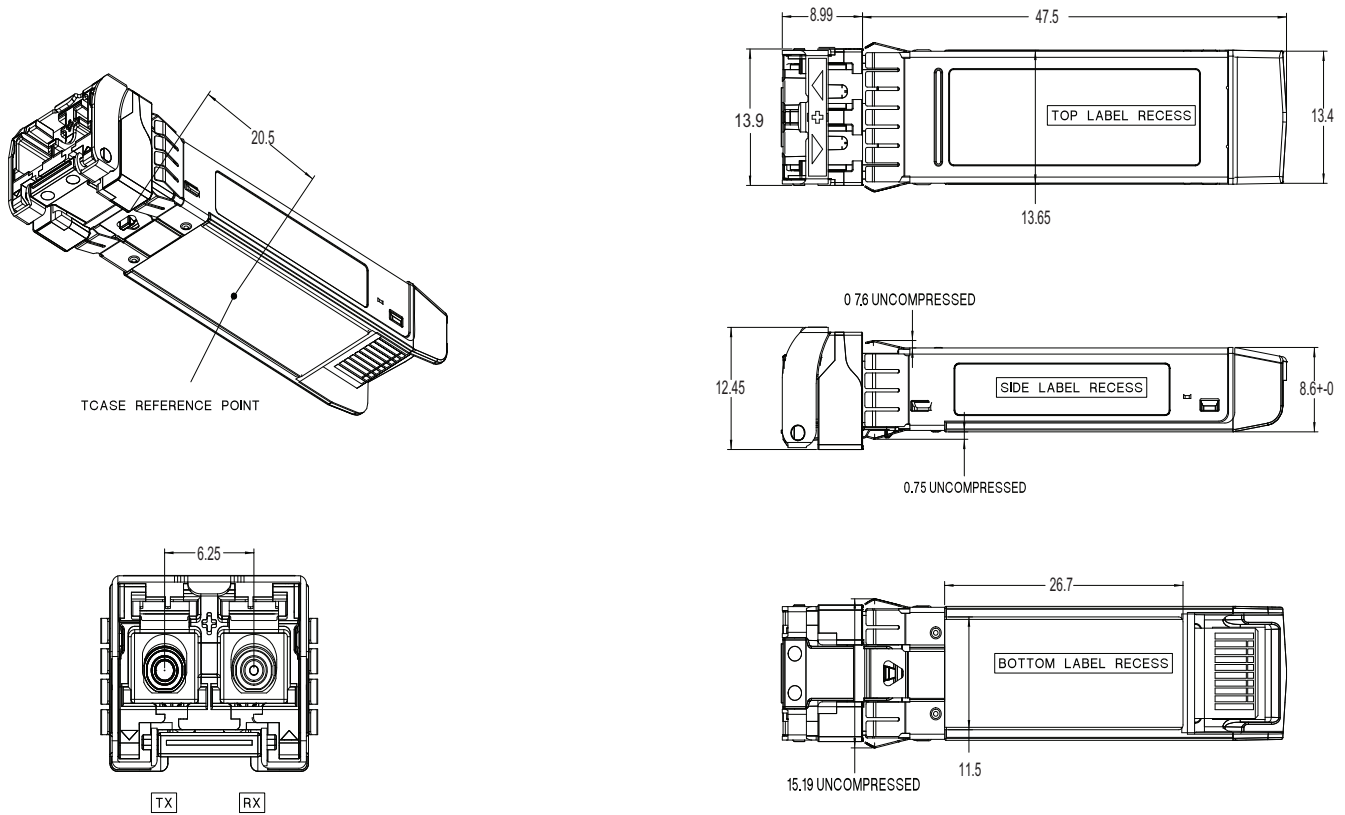

Copyright © 2005–2023 Broadcom. All Rights Reserved. The term “Broadcom” refers to Broadcom Inc. and/or its subsidiaries. For more information, go to www.broadcom.com. All trademarks, trade names, service marks, and logos referenced herein belong to their respective companies.

Broadcom reserves the right to make changes without further notice to any products or data herein to improve reliability, function, or design. Information furnished by Broadcom is believed to be accurate and reliable. However, Broadcom does not assume any liability arising out of the application or use of this information, nor the application or use of any product or circuit described herein, neither does it convey any license under its patent rights nor the rights of others.

