

Digital Semiconductor

DECchip 21140A PCI Fast Ethernet LAN Controller

Product Brief

October 1995

digital

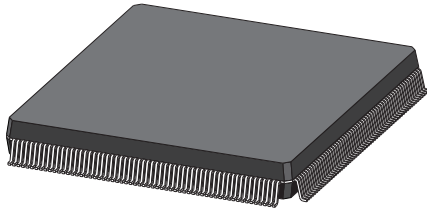

Description

The DECchip 21140A PCI Fast Ethernet LAN Controller is a PCI single-chip bus master, which supports direct memory access (DMA) and provides 10Mb/s and 10/100Mb/s networks. The DECchip 21140A has several additional features that are not available on the DECchip 21140, yet it remains pin and software compatible with the DECchip 21140. The DECchip 21140A is fully compliant with the IEEE 802.3 100BASE-T draft for Fast Ethernet.

The integration of the DECchip 21140A provides a low-cost 10Mb/s and 10/100Mb/s solution; it requires no external memory, and the 10/100Mb/s port contains a complete media-independent interface (MII).

Features

- Provides standard 10/100Mb/s MII
- Contains onchip scrambler and PCS for CAT5 to significantly reduce cost of 100BASE-T solutions
- Supports full-duplex operation on both 10Mb/s and 10/100Mb/s ports
- Provides internal and external loopback capability on both ports
- Contains a variety of flexible address filtering modes
- Offers a unique, patented solution to Ethernet capture-effect problem
- Contains large independent receive and transmit FIFOs, with no additional onboard memory required
- Includes a powerful onchip DMA with programmable PCI burst size, providing for low CPU utilization
- Implements unique, patent-pending intelligent arbitration between DMA channels, preventing underflow or overflow
- Supports PCI clock speed frequency from dc to 33 MHz; network operational with PCI clock from 20 MHz to 33 MHz
- Supports an unlimited PCI burst
- Supports PCI read multiple command*
- Supports early interrupts on transmit*
- Implements low-power management with two power-saving modes (sleep or snooze)*
- Supports both PCI 5.0-V and 3.3-V signaling environments*
- Supports big or little endian byte ordering for buffer and descriptors*
- Contains 8-bit, general-purpose programmable register and LED support
- Provides MicroWire interface for serial ROM (1K and 4K EEPROM)
- Provides an upgradable boot ROM (flash or EEPROM) interface of up to 256KB*
- Supports automatic loading of subvendor ID configuration register*
- Implements JTAG-compatible test access port with boundary-scan pins
- Supports IEEE 802.3, ANSI 8802-3, and Ethernet standards
- Implements low-power, 3.3-V (CMOS) technology

*Indicates DECchip 21140A features that are not available on the DECchip 21140.

DECchip 21140A Microarchitecture

The DECchip 21140A has a direct interface to the PCI local bus. It communicates with the host processor by using onchip control and status registers, and a shared host memory area. Most of the required setup and initialization is done after power-up. The DECchip 21140A software interface and data structures are optimized to minimize the host CPU load and to allow for maximum flexibility in the buffers' descriptor management. The DECchip 21140A comes with large onchip FIFOs, so no additional onboard memory is required. The two FIFOs and the internal microarchitecture provide complete support for full-duplex operation.

On the network side, the DECchip 21140A has separate 10/100Mb/s and 10Mb/s ports. It provides a direct interface to the external 10/100Mb/s and 10Mb/s front-end decoder (ENDEC), and it contains the complete MII interface. The DECchip 21140A includes an onchip PCS and scrambler to reduce the cost of 100BASE-T (CAT5 cabling) implementation.

Figure 1 shows the functional groups of the DECchip 21140A interface pins.

Figure 1 DECchip 21140A Pin Interface

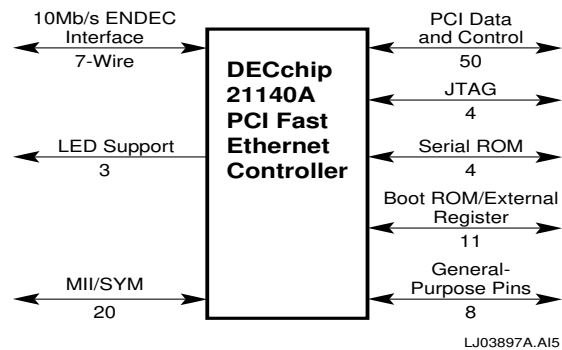

System Application Examples

The DECchip 21140A is optimized for PCI-based systems. It implements a direct interface to 10/100Mb/s ENDEC for 100BASE-T (unshielded twisted-pair CAT5), and it ensures complete MII compliance. The DECchip 21140A also implements a direct interface to external 10Mb/s ENDEC (AUI and 10BASE-T).

The DECchip 21140A is a high-performance, highly integrated solution for a variety of applications, such as:

- Cost-effective, high-performance PCI-to-Fast Ethernet adapter card
- PCI-based internetworking applications such as a Fast Ethernet switch or a Fast Ethernet router port
- Low-cost Fast Ethernet bridge

Figure 2 shows a possible adapter design using the DECchip 21140A. This adapter is capable of interfacing to both 10Mb/s Ethernet and 10/100Mb/s Fast Ethernet networks.

Figure 2 10Mb/s and 10/100Mb/s Fast Ethernet PCI Adapter

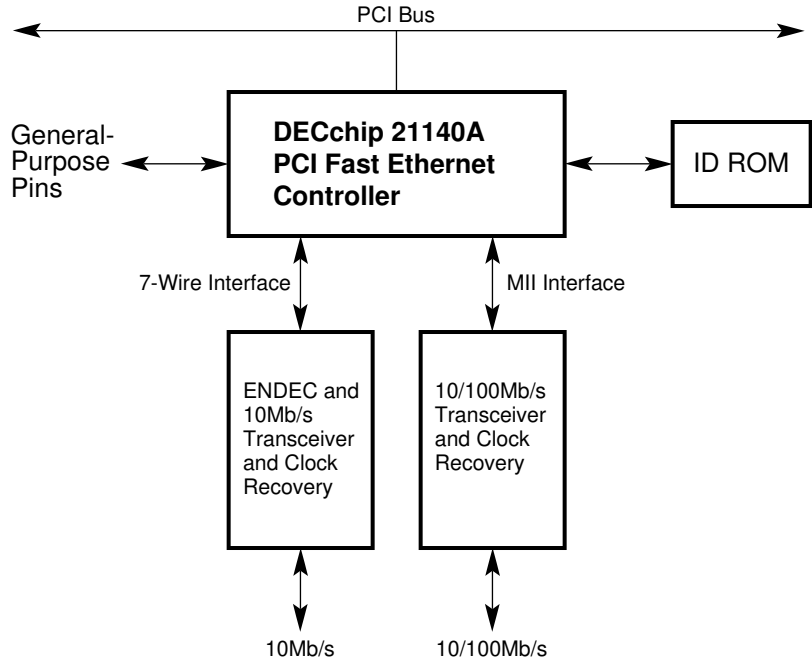

LJ03898B.A15

Figure 3 shows an example of a PCI-based bridge and Ethernet switch that uses the DECchip 21140A for the Fast Ethernet connection and several DECchip 21041 Ethernet controllers for the 10Mb/s connections.

Figure 3 PCI-Based Bridge and Switch

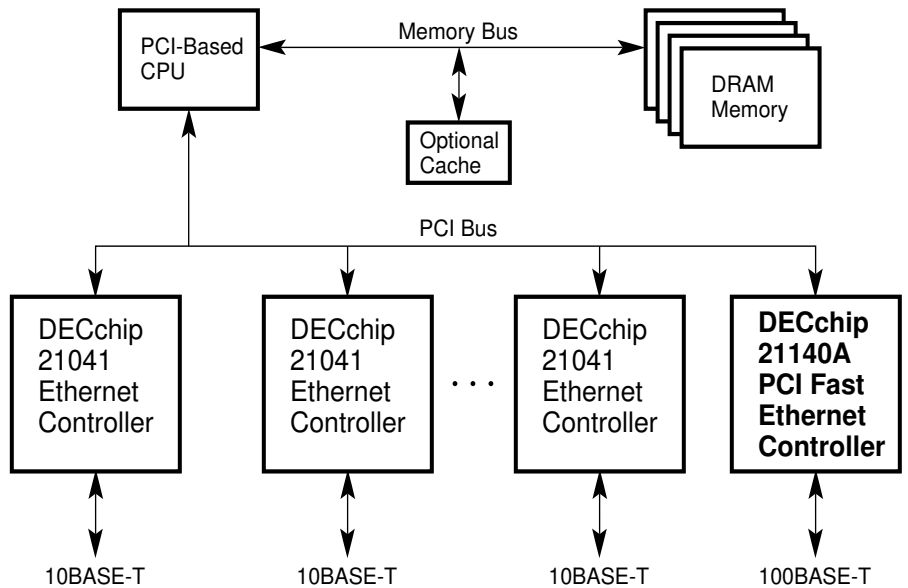

LJ03899A.A15

Figure 4 shows a possible implementation of a Fast Ethernet, 2-port bridge.

Figure 4 Fast Ethernet, 2-Port Bridge

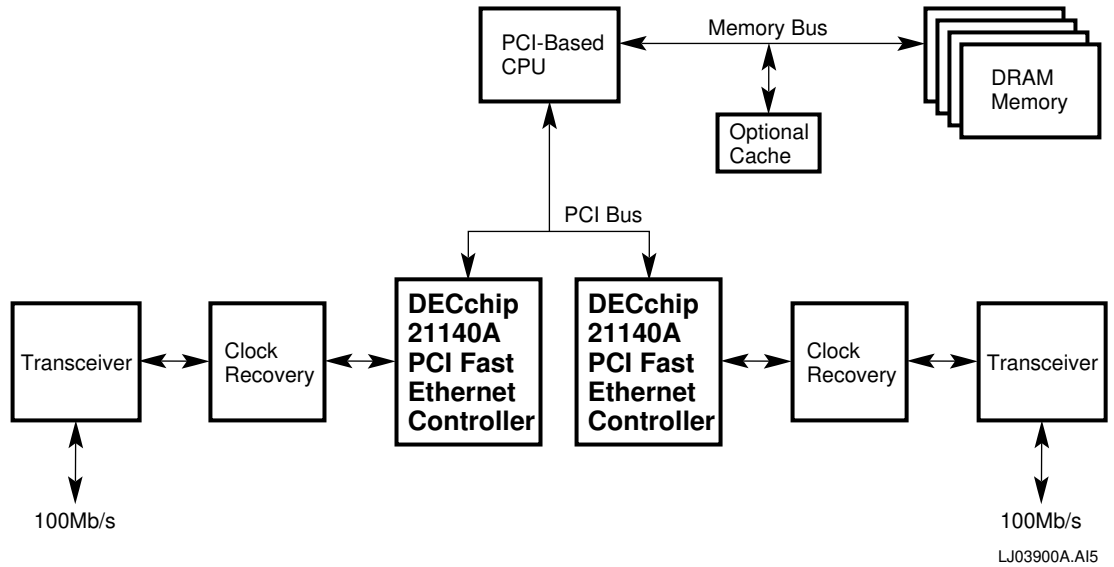

Complete Solution

A DECchip 21140A evaluation board kit provides all the tools necessary for hardware engineers to design a PCI Fast Ethernet Controller board for a variety of products.

The kit includes a PCI evaluation board with both 100BASE-TX and 10BASE-T connections. It also includes software drivers, documentation, schematics, and gerber files.



DECchip 21140A Characteristics	
Characteristic	Specification
Power supply	vdd =3.3 V vdd_clamp =5 V or 3.3 V
Operating temperature	0°C to 70°C
Storage temperature range	-55°C min, +125°C max
Power dissipation (typical)	0.5 W @ vdd =3.3 V with 33-MHz PCI clock
Package	144-pin PQFP

For More Information

To learn more about the availability of the DECchip 21140A and evaluation board kit, contact your local semiconductor distributor. To learn more about Digital Semiconductor's product portfolio, contact the Digital Semiconductor Information Line:

1-800-332-2717

Outside North America, call:

+1-508-628-4760

While Digital believes the information in this publication is correct as of the date of publication, it is subject to change without notice.

© Digital Equipment Corporation 1995.

All rights reserved.
Printed in U.S.A.

EC-QN7MA-TE

DEC, DECchip, Digital, Digital Semiconductor, and the DIGITAL logo, are trademarks of Digital Equipment Corporation.

Digital Semiconductor is a Digital Equipment Corporation business.

IEEE is a registered trademark of The Institute of Electrical and Electronics Engineers, Inc.

MicroWire is a registered trademark of BankAmerican Corporation.

All other trademarks and registered trademarks are the property of their respective owners.